



**GB** *Use and maintenance manual*

## General Index

<b>1. FOREWORD</b>	<b>3</b>
1.1 GENERAL	3
1.2 PURPOSE OF THE MANUAL	3
1.3 WHERE AND HOW TO KEEP THE MANUAL	3
1.4 MANUAL UPGRADES	3
1.5 COLLABORATION WITH USERS	4
1.6 MANUFACTURER	4
1.7 MANUFACTURER'S RESPONSIBILITY AND WARRANTY	4
1.7.1 <i>Terms of warranty</i>	4
1.8 TECHNICAL ASSISTANCE SERVICE	5
1.9 COPYRIGHT	5
<b>2. MACHINE DESCRIPTION</b>	<b>6</b>
2.1 PURPOSE	6
2.2 TECHNICAL SPECIFICATIONS	6
2.3 DIMENSIONS AND WEIGHTS	6
<b>3. STARTING</b>	<b>7</b>
<b>4. CONTROL PANEL AND COMPONENTS</b>	<b>8</b>
4.1 AUTOMATIC DISTANCE AND DIAMETER GAUGE	8
<b>5. USE OF THE WHEEL BALANCER</b>	<b>9</b>
5.1 INITIAL SCREEN	9
5.1.1 <i>SCREEN-SAVE SCREEN</i>	9
5.2 PRESETTING OF WHEEL DIMENSIONS	9
5.2.1 <i>Automatic presetting (👉 also CORRECTION MODE)</i>	9
5.2.1.1 <i>Standard wheels</i>	9
5.2.1.2 <i>ALUS wheels</i>	10
5.2.2 <i>Manual presetting</i>	11
5.3 USER CONTROL	11
5.3.1 <i>To save USER</i>	11
5.3.2 <i>To call USER</i>	11
5.4 RESULT OF MEASUREMENT	12
5.4.1 <i>Indication of exact correction weight position</i>	12
5.4.2 <i>"SPLIT" control</i>	13
5.4.3 <i>Automatic minimization of static unbalance</i>	13
5.5 WHEN AND WHY MATCHING	14
5.5.1 <i>Presetting of tolerance on the machine</i>	15
5.5.2 <i>Value of static unbalance, correlated with eccentricity</i>	15
5.5.3 <i>Value of unbalance corresponding to eccentricity</i>	15
5.6 ECCENTRICITY MEASUREMENT (OPTIONAL)	15
<b>6. MENU</b>	<b>16</b>

6.1	MENU ACCESS DIAGRAM	16
6.2	UNBALANCE OPTIMIZATION	17
<b>7.</b>	<b>SETUP</b>	<b>17</b>
7.1	LANGUAGE	17
7.2	UNIT OF UNBALANCE MEASUREMENT	17
7.3	UNBALANCE DISPLAY PITCH	17
7.4	UNBALANCE DISPLAY THRESHOLD FOR TRUCK/CAR	17
7.5	UNBALANCE DISPLAY PITCH FOR TRUCK/CAR	17
7.6	SPIN WITH GUARD CLOSED	18
7.7	SCREEN-SAVER TIME	18
7.8	VISUAL ECCENTRICITY CHECK	18
7.9	ACOUSTIC SIGNAL	18
<b>8.</b>	<b>SPECIAL CALIBRATIONS AND FUNCTIONS</b>	<b>19</b>
8.1	CONTROL OF ECCENTRICITY MEASUREMENT	19
8.2	PRESETTING THE CUSTOMER AND USER NAME	19
8.3	CALIBRATIONS	19
8.3.1	<i>Gauge calibration</i>	19
8.3.1.1	<i>Distance gauge calibration</i>	19
8.3.1.2	<i>Diameter gauge calibration</i>	19
8.3.2	<i>Balancing machine calibration</i>	19
8.4	WHEEL BALANCING MACHINE SELF TEST	19
<b>9.</b>	<b>DIAGNOSTICS</b>	<b>20</b>
<b>10.</b>	<b>MAINTENANCE</b>	<b>22</b>
10.1	GENERAL	22
10.1.1	<i>Introductory notes</i>	22
10.1.2	<i>Safety rules</i>	22
10.1.3	<i>Replacing fuses</i>	22
10.1.4	<i>To replace the driving pulley</i>	22
<b>11.</b>	<b>DISPOSAL</b>	<b>23</b>
11.1	DISPOSING OF THE BALANCER	23
11.2	DISPOSING OF ELECTRONICS COMPONENTS	23
<b>12.</b>	<b>SPARE PARTS</b>	<b>23</b>
12.1	IDENTIFICATION AND ORDERING METHOD	23
<b>13.</b>	<b>ATTACHED DOCUMENTATION</b>	<b>23</b>

# 1. Foreword



## WARNING

THIS MANUAL IS AN INTEGRAL PART OF THE INSTALLATION MANUAL WHICH SHOULD BE CONSULTED CONCERNING STARTING AND USING THE MACHINE SAFELY.

## 1.1 GENERAL

The machine has been constructed in conformity with the current EC Directives and the technical standards implementing the requirements, as stated in the declaration of conformity issued by the manufacturer and attached to the manual.

This publication, hereinafter simply referred to as '**manual**', contains all the information required to safely use and service the machine referred to in the Declaration of Conformity.

This appliance, hereinafter is generically referred to as '**machine**'.

The manual addresses operators instructed on the precautions to take in relation to the presence of electric current and moving devices.

This publication is intended for all 'users' who as far as within their competence need to and/or are obliged to give instructions to others or operate on the machine themselves.

These persons can be identified as follows:

- operators directly involved in transporting, storing, installing, using and servicing the machine from when it is put on the market until when it is scrapped;
- direct private users.

The original Italian text of this publication constitutes the only reference to resolve any interpretation controversies related to the translation into the European Community languages.

This publication forms an integral part of the machine and must therefore be kept for future reference until final dismantling and scrapping of the machine.

## 1.2 PURPOSE OF THE MANUAL

This manual, and the installation manual, contains the instructions required to use the machine safely and carry out routine maintenance work.

Any calibrations, adjustments and extraordinary maintenance operations are not considered in this document as they may only be performed by the service engineer who must work on the machine according to the technical and rated characteristics for which it was built.

Though it is fundamental to read this manual, it cannot replace skilled technical staff who must be adequately trained beforehand.

The foreseen use and configurations of the machine are the only ones allowed by the manufacturer; do not attempt to use the machine in a different way.

Any other use or configuration must be agreed in advance with the manufacturer in writing and in this case an annex will be attached to this manual.

For use, the user must also comply with the specific workplace legislation in force in the country where the machine is installed.

The manual also refers to laws, directives, etc., that the user must know and consult in order to accomplish the goals that the manual sets out to achieve.

## 1.3 WHERE AND HOW TO KEEP THE MANUAL

This manual (and relative attachments) must be kept in a safe and dry place and must always be available for consultation.

Make a copy and keep it in the archive.

When exchanging information with the manufacturer or the technical assistance staff authorised by the former, quote the rating plate information and the serial number of the machine.

**This manual must be kept for the entire lifetime of the machine**, and if necessary (e.g.: damage making all or some of it illegible, etc.) the user must request another copy exclusively from the manufacturer, quoting the publication code indicated on the cover.

## 1.4 MANUAL UPGRADES

This manual is an integral part of the machine and reflects the state of the art at the moment it was put on the market. The publication complies with the directives in force on that date; the manual cannot be considered inadequate

as a result of regulatory updates or modifications to the machine.

Any manual upgrades that the manufacturer may see fit to send to users will become an integral part of the manual and must be kept together with it.

## 1.5 COLLABORATION WITH USERS

The manufacturer will be pleased to provide its customers with any further information they may require and will consider proposals for improving this manual in order to more fully satisfy the requirements it was written for.

**In case of transfer of ownership of the machine, which must always be accompanied by the use and maintenance manual, the original user must inform the manufacturer of the name and address of the new user in order to allow it to send the new user any communications and/or updates deemed to be indispensable.**

***This publication is the property of the Manufacturer and may not be fully or partly reproduced without prior written agreement.***

## 1.6 MANUFACTURER

The machine identification data is indicated on the plate mounted on the machine.

The plate below is shown for the sake of example.

MODEL	<input type="text"/>	VER	<input type="checkbox"/>
SER. N°	<input type="text"/>		
<input checked="" type="checkbox"/> V	<input type="text"/>	CE	KW <input type="text"/>
<input type="checkbox"/> A	<input type="text"/>		Hz <input type="text"/>
			T° [C] <input type="text"/>
PHASE	1	AIR SUPPLY	Kg/cm <sup>2</sup> <input type="text"/>
<input type="text"/>			

## 1.7 MANUFACTURER'S RESPONSIBILITY AND WARRANTY

In order to make use of the manufacturer's warranty, the user must scrupulously observe the precautions contained in the manual, in particular he must:

- never exceed the limits of use of the machine;
- always constantly and carefully clean and service the machine;
- have the machine used by people of proven capacity and attitude, adequately trained for the purpose.

*The manufacturer declines all direct and indirect liability caused by:*

- use of the machine in a different way from that indicated

in this manual

- use of the machine by people who have not read and fully understood the contents of this manual;
- use in breach of specific regulations in force in the country of installation;
- modifications made to the machine, software and operating logic, unless authorised by the manufacturer in writing;
- unauthorised repairs;
- exceptional events.

Transfer of the machine to a third party must also include this manual; failure to include the manual automatically invalidates all the rights of the purchaser, including the terms of warranty, where applicable.

If the machine is transferred to a third party in a country with a different language from the one written in this manual, the original user shall provide a faithful translation of this manual in the language of country in which the machine will operate.

### 1.7.1 Terms of warranty

The Manufacturer guarantees the machines it manufactures against all manufacturing or assembly faults for 12 (twelve) months from the date of collection or delivery.

The Manufacturer undertakes to replace or repair any part which it deems to be faulty free of charge at its factory, carriage paid.

If a Manufacturer's repairman (or a person authorised by the same) is required to work at the user's facilities, the relative travel expenses and board and lodging shall be charged to the user.

The free supply of parts under warranty is always subject to the faulty part being inspected by the manufacturer (or a person authorised by the same).

The warranty is not extended following repairs or other work done to the machine.

*The warranty does not cover damage to the machine deriving from:*

- transport;
- neglect;
- improper use and/or use not in compliance with the instructions in the operating manual
- incorrect electrical connections.

*The warranty is invalidated in case of:*

- repairs made by people who were not authorised by the manufacturer;
- modifications that were not authorised by the manufacturer;
- use of parts and/or equipment that were not supplied or approved by the manufacturer;
- removal or alteration of the machine identification plate.

## **1.8 TECHNICAL ASSISTANCE SERVICE**

For technical assistance requirements, contact the Manufacturer or authorised Dealer directly, always quoting the model and serial number of the machine punched on the identification plate.

## **1.9 COPYRIGHT**

The information contained in this manual may not be disclosed to third parties. Partial or total duplication, unless authorised by the Manufacturer in writing, through photocopying, duplication or other systems, including electronic acquisition, is breach of copyright and can lead to prosecution.

## 2. Machine description

### 2.1 PURPOSE

It is a wheel balancing machine for trucks, light commercial vehicles and cars.

It features excellent performance and is equipped with a manual lift with sliding carriage which allows mounting wheels of up to 250 kg on the spindle and, when fitted on the balancing machine, must not interfere with any fixed part of the machine, excluding the shaft and support adaptor. The machine is supplied with equipment enabling the vast majority of car and truck wheels available on the market to be fitted.

Other wheels with special dimensions, geometry and centring require special adaptors supplied on request.

The wheel balancing machine can operate without guards since the balancing speed is only 100 rpm.

It functions properly without having to fasten it to the floor with wheels weighing up to 160 kg; for heavier wheels, fasten it at the points indicated.

Do not mount anything other than motorbike, car or truck tyres on the wheel balancer.

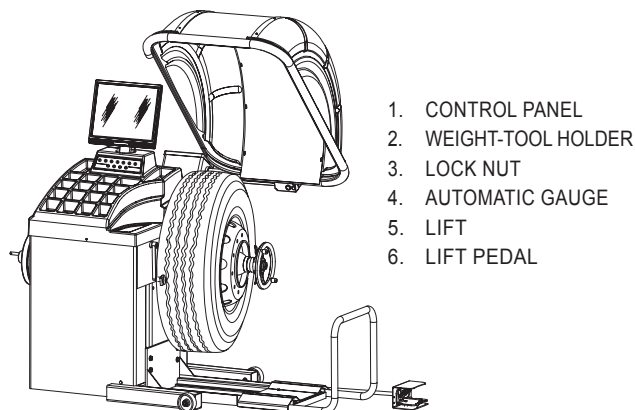
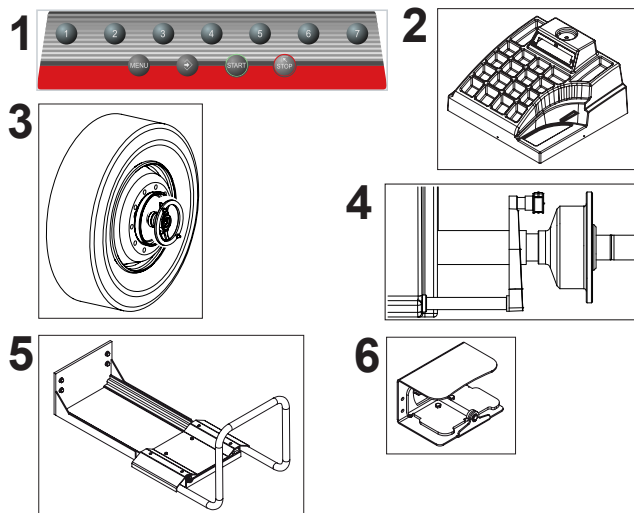

The main features include:

- machine settings menu
- optimisation of tyre and rim unbalance
- STATIC programme, ALUS; SPLIT; USER control; indication of exact correction weight position Self diagnostics; Self calibration
- automatic minimisation of static unbalance.

### 2.2 TECHNICAL SPECIFICATIONS

The following data refers to the balancer in its standard configuration.

Single-phase power supply	115 / 230 V 50/60 Hz
Protection class	IP 54
Max.power consumption	0,8 kW
Balancing speed	100 min <sup>-1</sup> (car) 70 min <sup>-1</sup> (truck)
Measurement uncertainty	1 gr. (car) 10 gr. (truck)
Cycle time for wheel	8+20 sec.
Average noise	< 70dB (A)
Rim width setting range	1.5" + 20" or 40 + 510 mm
Diameter setting range	10" + 30" or 265 + 765 mm
Min/max. compressed air pressure	8 + 10 kg/cm <sup>2</sup>
	approx. 0.8 to 1 Mpa;
	approx. 8 to 10 bar;
	approx. 115 to 145 psi.
Maximum wheel weight	< 250 Kg.
Machine weight	210 Kg.

### 2.3 DIMENSIONS

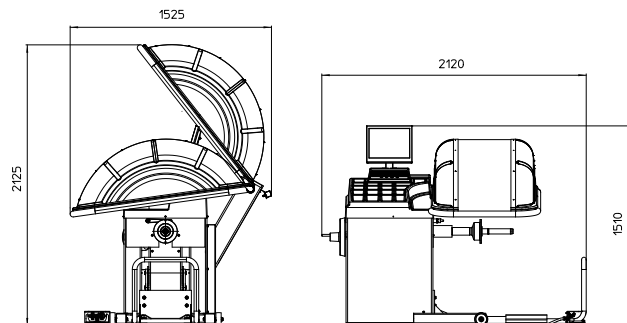

# 3. Starting



**WARNING**

BEFORE SWITCHING ON THE MACHINE, MAKE SURE THAT ALL THE CONNECTIONS DESCRIBED IN THE **INSTALLATION** CHAPTER HAVE BEEN MADE CORRECTLY.

THE FOLLOWING OPERATIONS INVOLVE A POTENTIAL RISK FOR THE OPERATOR, GIVEN THE PRESENCE OF VOLTAGE ON THE EQUIPMENT. THE **PERSONAL PROTECTIVE EQUIPMENT** DESCRIBED IN THE **INSTALLATION** MANUAL MUST BE WORN AND WORK MUST BE DONE WITH DUE CARE AND ATTENTION.

OPERATIONS MAY ONLY BE PERFORMED BY A SPECIALISED TECHNICIAN.

Before powering the machine, carry out the following checks:

1. check that the balancing machine touches the floor at the three support points;

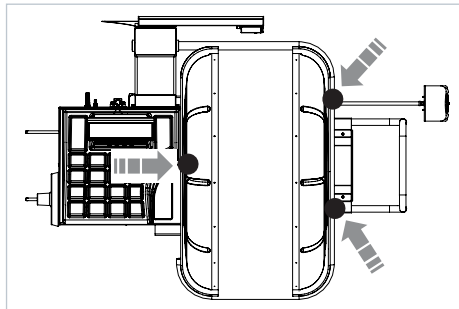

2. make sure that all the parts of the balancer are correctly connected and fixed;
3. make sure that the parameters (voltage and frequency) of the mains power supply are compatible with those indicated on the rating plate of the balancer;
4. make sure the power cable is correctly connected;
5. make sure the machine shaft and flange hole are clean.



**CAUTION**

ANY TRACES OF DIRT MAY AFFECT BALANCING ACCURACY.

6. To switch on the balancer press the switch on the left-hand side of the machine

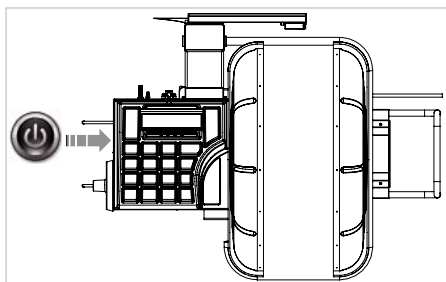

7. This pedal controls ascent and descent of the lift integrated in the machine. The carriage is manually driven.

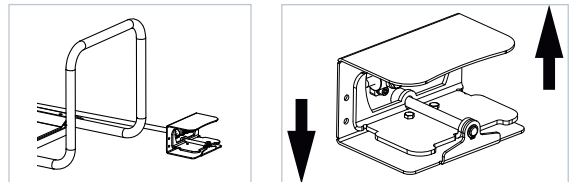

8. Position the wheel on the terminal with the inner part facing the balancer;

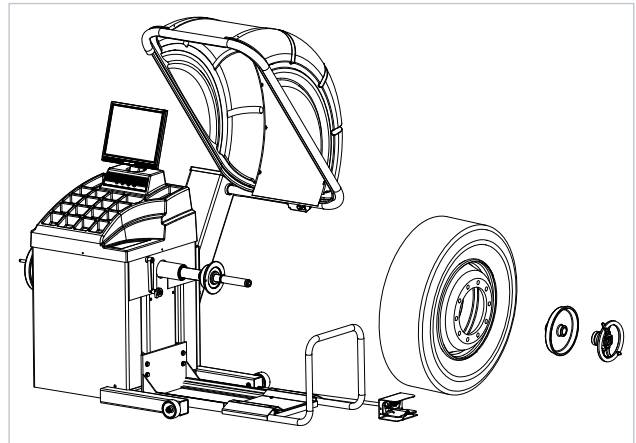

9. Firmly attach the wheel to the balancer shaft using the lock nut.
10. At this point, you can read the tyre measurements and perform balancing.

## 4. Control panel and components

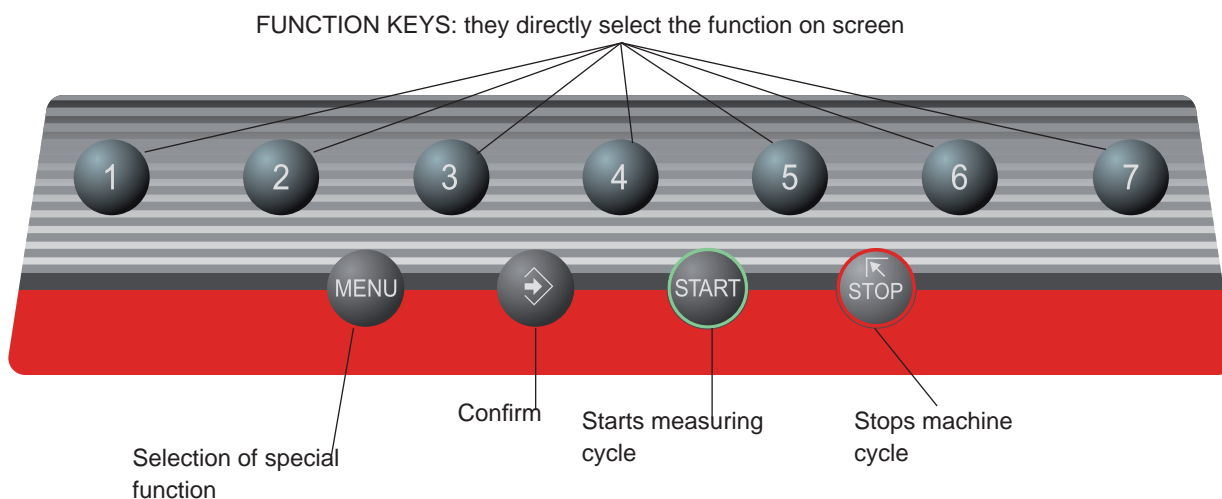

### CAUTION

PRESS THE BUTTONS WITH YOUR FINGERS.  
NEVER USE THE COUNTERWEIGHT GRIPPERS OR OTHER POINTED OBJECTS!  
THE TFT MONITOR IS NOT A TOUCH SCREEN TYPE.

### 4.1 AUTOMATIC DISTANCE AND DIAMETER GAUGE

This gauge allows measurement of the distance of the wheel from the machine and the wheel diameter at the point of application of the counterweight. It also allows correct positioning of the counterweights on the inside rim by using the specific function (👉 **INDICATION OF EXACT CORRECTION WEIGHT POSITION**) which allows reading, on the monitor, the position used for the measurement within the rim (for calibration, see the corresponding section).



# 5 Use of the wheel balancer

The monitor shows several information and suggests various alternative ways of use to the operator. This is through various "screens".

## 5.1 INITIAL SCREEN



Buttons enabled:

- MENU** : main functions screen (👉 **MENU ACCESS DIAGRAM**)
- 2** : selecting static correction
- START** : balancing spin (see **RESULT OF MEASUREMENT**)

**Dimensions gauge:** when extracted, the Dimensions screen is selected (👉 **PRESETTING OF WHEEL DIMENSIONS**). If the machine remains on the initial screen for a certain amount of time without being used, the system is automatically switched to a screen-save. Striking of any key, movement of the wheel of distance + diameter gauge will cause automatic switching from the screen-save menu to the initial screen.

### 5.1.1 SCREEN-SAVE SCREEN

Name of the wheel balancer's owner. Can be preset via the monitor.



## 5.2 PRESETTING OF WHEEL DIMENSIONS

### 5.2.1 Automatic presetting (👉 also **CORRECTION MODE**)



The screen appears upon removing the distance + diameter gauge. The "dimension acquired" message is indicated by the correction weight symbol, which changes from blue to red.

#### 5.2.1.1 Standard wheels

Using the special grip, move the end of the gauge against the rim in one of the positions A/B indicated in the figure.

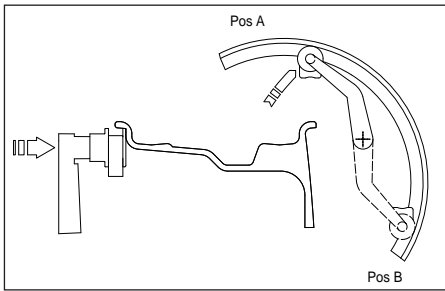

b) **Adhesive weight:** in the position indicated below.

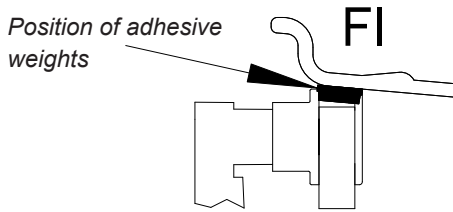

**INDICATION**

Always use the round part of the striker plate.

Hold the gauge in position for at least 2 seconds.

If the acoustic signal is enabled (🔊 **ACOUSTIC SIGNAL**), the acquisition of the dimensions is accompanied by a "beep".

Set the distance+diameter gauge to the rest position: the current width value is displayed inside the tyre.

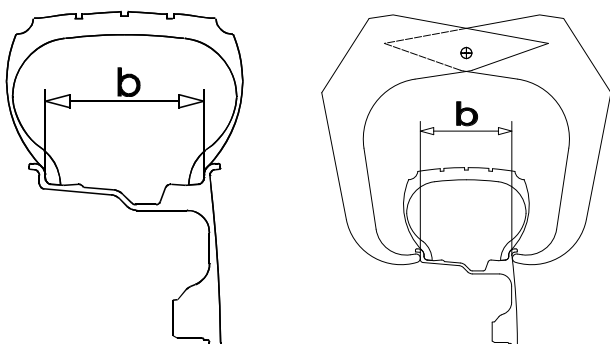

The other enabled buttons are:

3 / 5 Select the type of weight to apply (👉 **CORRECTION METHODS**).

1 / 2 User call/save control.

6 / 7 Set the nominal width, which is normally shown on the rim, or measure the width "b" with the caliper gauge provided.

STOP Return to initial frame.

START Launch balancing.

**5.2.1.2 ALUS wheels**

After the measurement performed for the FI inner side, as indicated in the figure below, pull out the gauge again to store the data for the FE outer side; choose position A or B at your choice. Keep this position for at least 2 seconds. The counterweight symbols change colour. When the acoustic signal is enabled (🔊 **ACOUSTIC SIGNAL**), the acquisition is accompanied by a "beep".

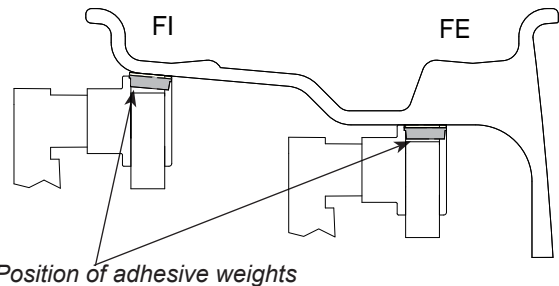

Position of adhesive weights

After having detected the dimensions, use the 3 key to indicate the type of correction selected for the inner side.

The following buttons are enabled:

1 / 2 Management of save user recall

3 Selection of clip or adhesive weight for inside.

4 Only for automatic width option:  
The **L.T.** key (**LIGHT TRUCK**) used to improve the dimensional calibration of large diameter wheels such as off-road, trucks, wheels which protrude significantly from the rim. Press the **L.T.** key, after distance measurement, immediately before

lowering the guard for Width Measurement. The option is disengaged at the end of current Width Measurement.

- 6 Selecting the manual dimension presetting screen
- 7 / STOP Return to initial screen.
- START Balancing run.

### 5.2.2 Manual presetting

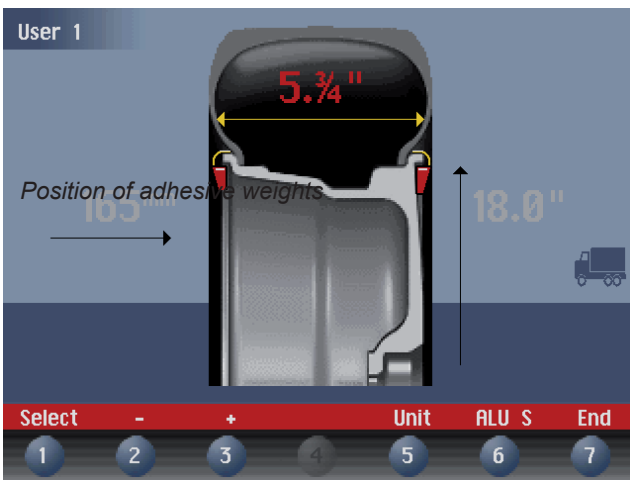

If necessary, the dimensions can be inserted or edited in manual mode as follows:

- press MENU + 4
- press 1 to select the dimension to be preset (red).  
press 2 / 3 to preset the required value.
- press 5 to change unit of measurement.
- press 6 to preset the dimensions for the ALUS correction mode

#### Definition of dimensions for correction using spring weights:

- d = DIAMETER:** Preset the nominal diameter stamped on the rim.
- b = WIDTH:** Preset the nominal width indicated on the rim (STANDARD WHEELS).
- a = DISTANCE:** Preset the distance of the inside of the wheel from the machine, after measuring it with relative gauge.

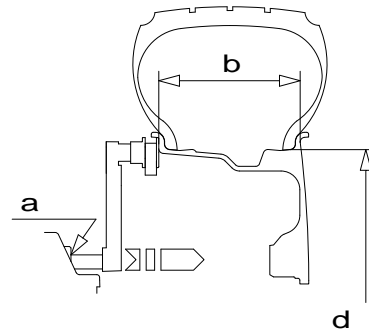

In the event of correction type other than standard (spring weight), follow the instructions on the screen for correct detection of dimensions.

### 5.3 USER CONTROL



The wheel balancer can be used simultaneously by 4 different users who, through a simple sequence, can memorize their work condition and call it when needed. The users' names can be memorized (**PRESETTING THE CUSTOMER AND USER NAME**).

#### 5.3.1 To save USER

- Preset the dimensions correctly according to the procedures already described in sections **AUTOMATIC PRESETTING**.
- Press MENU; the "MENU" window appears on the monitor.
- Press 2; a window appears with the list of available USERS. The current user is displayed in red.
- Press the number corresponding to the required USER. The system returns to the initial screen automatically.

#### 5.3.2 To call USER

- Perform a measuring spin with any dimensions.
- Press button MENU; the "MENU" window appears on the screen.

- Press **1** : a window appears with the list of available USERS. The current user is displayed in red.
- Press the number corresponding to the required USER. The system automatically returns to the initial screen with recalculation of the unbalance values on the basis of the effective dimensions of the USER called.

**INDICATION**

*The dimensions memorized as USER are lost when the machine is switched off. The USER control is also valid for the ALUS dimensions.*

*The current USER is always displayed in the Measurements and Dimensions screens.*

**5.4 RESULT OF MEASUREMENT**



After performing a balancing spin, the unbalance values are displayed as well as arrows useful for positioning the point of application of the correction weight. After positioning of the wheel, apply the weight in the 12 o'clock position. When the beep signal is enabled (🔊 **ACOUSTIC SIGNAL**), reaching of the correction position is accompanied by a "beep". If the wheel clamp option is enabled (🔒 **WHEEL LOCKING**), the wheel is automatically clamped in the correction position. If the unbalance is less than the chosen threshold value, the "OK" appears instead of the unbalance value to indicate, on that particular side, the wheel is in tolerance; the residual unbalance can be displayed by pressing button **1** with an accuracy of 0.5 g (0.1 oz).

The following buttons are enabled:

- 1** Display of residual unbalance
- 2** Selection of correction mode (STATIC/DUAL SURFACE). When the mode is changed, the unbalance values are recalculated automatically on the basis of the previous spin.
- 4** When this push button is held down for more than 1.5 seconds, eccentricity measurement is temporarily disabled (enabled in **SPECIAL FUNCTIONS**). To re-enable eccentricity measure

ment, press push button [4] again for more than 1.5 seconds. Every time the machine is switched on, the status of eccentricity measurement reflects the settings in **SPECIAL FUNCTIONS**.

- 6** Split control for splitting of unbalance over preset table components ("**SPLIT CONTROL**"). Button only enabled in STATIC or ALUS correction.
- 7** Indication of the longitudinal position of the unbalance (**INDICATION OF EXACT CORRECTION WEIGHT POSITION**) is enabled.
- MENU** For selection of special functions
- START** Balancing spin.

**INDICATION**

*If the machine remains on this screen without being used for more than the time preset in the Setup parameters, the screen automatically returns to the screen-save.*

**5.4.1 Indication of exact correction weight position**

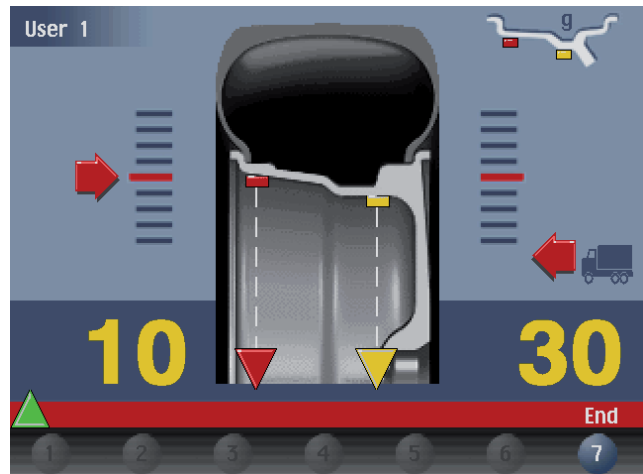

It is possible use this function in the event of correction of the external side using an adhesive weight placed inside the rim. Remember to thoroughly clean the application areas. This function allows cancelling approximations in the mounting of counterweights with consequent reduction of the residual unbalance. *From the measurement results frame:*

- Press button **7** from the Measurements screen.
- Pull out the rim distance+diameter gauge in **position A**, figure in **STANDARD WHEELS**. Approach of the weight to the correction position is indicated by a moving coloured arrow [ ▲ ].
- When a fixed arrow [ ▼ ] is reached, rotate the wheel to correction position (FI or FE) and apply the counterweight by turning the tip of the gauge towards the outside, into the position in which the pincers touches the wheel. Compensation is made for the fact that the weight application position is no longer at 12 o'clock (where appro-

ropriate use the weight pusher).

**INDICATION**

when the acoustic signal is enabled (ACOUSTIC SIGNAL), the reaching of a fixed arrow [▽] is accompanied by a "beep".

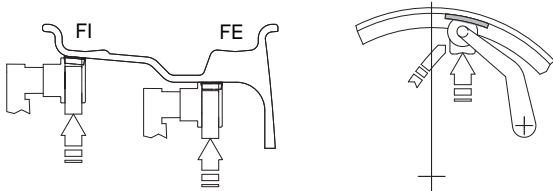

**5.4.2 "SPLIT" control**

SPLIT is only possible in the event of static unbalance or ALUS external side and is used to hide any adhesive weights correcting unbalance behind the rim spokes.



To split the unbalance detected in two different positions, proceed as follows :

1. Position static unbalance or ALUS external side in the correction position :



2. Select a spoke close to the 12 o'clock position to be corrected, move it into the 12 o'clock position and press button [6].
3. Turn the wheel in the rotation direction indicated on the unbalance display, bringing the second spoke to the 12 o'clock position and press button [6].



Turn the wheel in direction of rotation.



Turn the wheel in reverse direction of rotation.

4. At this stage, the screen shows the graphic display of the correction spokes with the relative weight of the unbalance detected.
5. Position the spokes indicated on screen in the 12 o'clock position and correct with the value displayed. Any error in this procedure is clearly shown on screen. Always follow the information provided by the wheel to optimize correction.

When SPLIT is enabled, the icon  appears on the left of the screen.

**5.4.3 Automatic minimization of static unbalance**

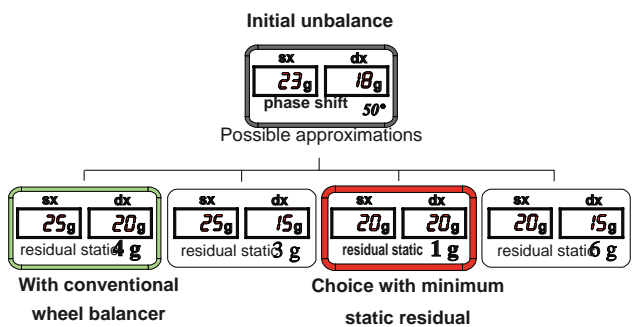

This program is designed to improve the quality of balancing without any mental effort or loss of time by the operator. In fact by using the normal commercially available weights, with pitch of 5 in every 5 g, and by applying the two counterweights which a conventional wheel balancer rounds to the nearest value, there could be a residual static unbalance of up to 4 g. The damage of such approximation is emphasized by the fact that static unbalance is cause of most of disturbances on the vehicle. This new function, resident in the machine, automatically indicates the optimum entity of the weights to be applied by approximating them in an "intelligent" way according to their position in order to minimize residual static unbalance.

### 5.5 WHEN AND WHY MATCHING

The software associated with eccentricity measurement is a powerful tool for determining the need to perform relative rotation between the rim and tyre in order to reduce the eccentricity of the wheel down to acceptable limits. The principle adopted is based on the consideration that a rim with acceptable tolerance, mounted with an acceptable tyre, can statistically generate a total eccentricity which is not acceptable but can be improved by matching.

Generally speaking, rim measurement is not necessary, accurate or useful because:

- To measure the rim it is necessary to remove the tyre. There can be coarse errors on the outside (e.g. aluminium wheels!)
- The two rim sides can be eccentric in a very different way. Therefore to which one to make reference? What is the effect on the tyre mounted?
- To improve the eccentricity of a wheel, **the rim should be eccentric**, to compensate the tyre. And viceversa.
- If after a rotation by 180° of a wheel, the value is still out-of-tolerance, either the tyre or rim are too eccentric: One of the two must be replaced!

Example 1

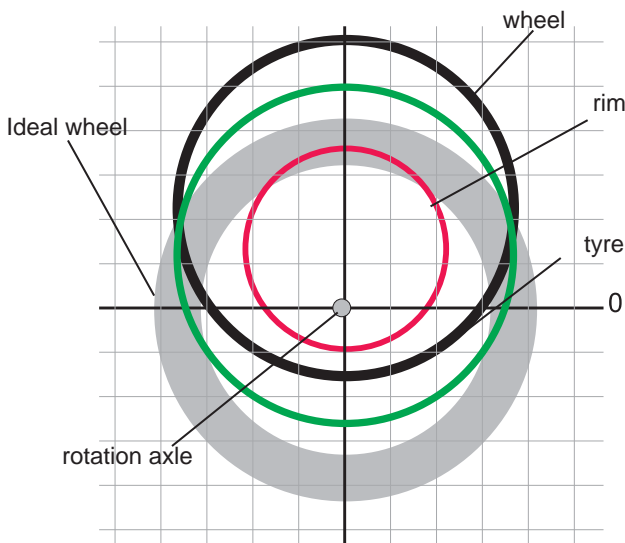

Rim + 0.8 mm  
Tyre + 0.6 mm

Wheel + 1.3 mm

*Eccentricity of the wheel is excessive, due to an acceptable rim or tyre but randomly placed in an "unfortunate" relative position.*

**SOLUTION:** Rotate the tyre on the rim by 180°  
**RESULT:** wheel eccentricity 0.3 - 0.4 mm (in tolerance)

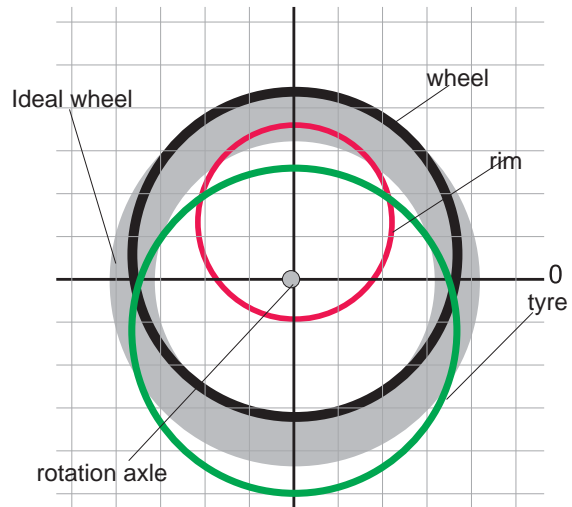

Rim + 0.8 mm  
Tyre - 0.6 mm

Wheel + 0.3 mm

*Eccentricity of the single items has been compensated.*

**The wheel is acceptable.**

Example 3

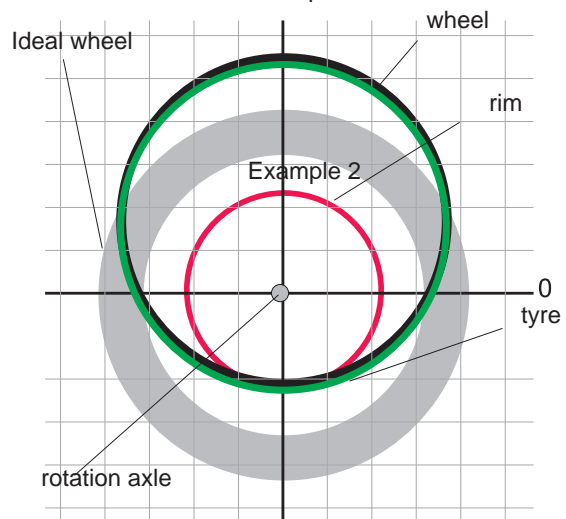

Rim 0 mm

Tyre + 1.2 mm

Wheel + 1,2 mm

*Eccentricity of the wheel cannot be compensated by the rotation because the rim is perfect!*

**SOLUTION:** Rotate the tyre on the rim by 180°  
**RESULT:** no improvement is obtained.

### 5.5.1 Presetting of tolerance on the machine

There is no general rule concerning acceptability of an eccentricity value. As a first approximation we consider it correct to use a threshold of 1 to 1.5 mm. The E/ECE/324 standard prescribes 1.5 mm as max. eccentricity of a rebuilt tyre.

### 5.5.2 Value of static unbalance, correlated with eccentricity

Clear indication is given in the Measurement screen of both the value and position of the static unbalance as well as the eccentricity. In fact, it is interesting to check the correlations of the two values, above all of the two positions. When the two positions have a similar angle ( $\pm 30^\circ$  one from the other), there is a **clear sign that an eccentricity is present which can be compensated by matching**.

### 5.5.3 Value of unbalance corresponding to eccentricity

For user's reference, the centrifugal force is calculated corresponding to a certain speed, compared to the force generated by the eccentricity present on the tyre (calculated with an approximate average elastic constant).

## 5.6 ECCENTRICITY MEASUREMENT (OPTIONAL)

The much enlarged figures show the outer tyre surface and axis of wheel rotation.

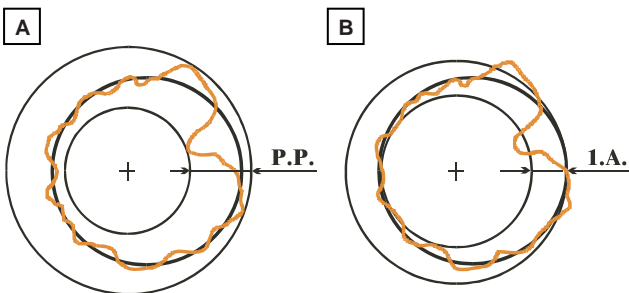
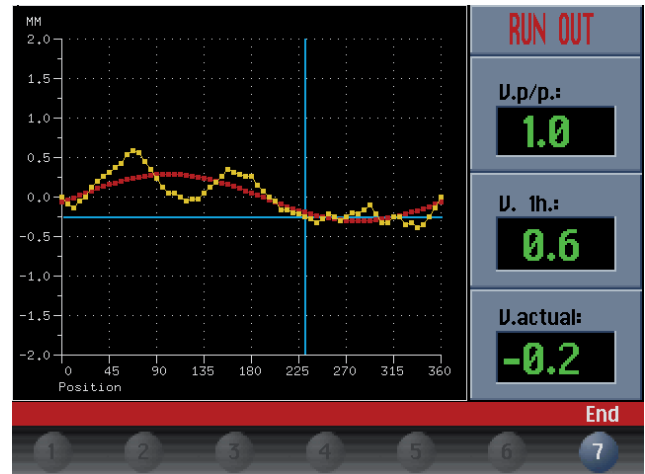

**Fig. A** - shows measurement of the total Peak-to-Peak eccentricity defined as maximum radial deviation of the tyre surface.

**Fig. B** - shows measurement of the eccentricity of the 1st harmonic, i.e. the eccentricity of that circle which "recopies" the tyre shape, by averaging the local deviations of the tyre from the round shape.

Obviously the P.P. measurement is normally greater than that of the 1st harmonic. Tyre manufacturers normally supply two different tolerances for the two eccentricities.

At the end of the balancing spin it is possible to automatically measure the eccentricity of the tyre through the SONAR sensor installed on the guard. The sensor should be positioned by hand in front of the tyre tread.



GRAPH 1 (yellow) : represents the actual Peak-to-Peak eccentricity.

GRAPH 2 (red) : represents the eccentricity of the 1st harmonic. For a wheel in optimum conditions, such graph should approach a straight line.

While rotating the wheel, the screen cursor indicates the current value, with the stage referred to the eccentricity measurement sensor.

The following buttons are enabled:

- 5** Start an eccentricity optimisation procedure (see **ECCENTRICITY OPTIMISATION**).
- 6** A box is displayed indicating the offset effect that that eccentricity of the first harmonic measured may have, at an average speed of 120 Km/h.
- 7** Return to measurement screen.

# 6. Menu

## 6.1 MENU ACCESS DIAGRAM

• The symbol **▶▶▶** indicates the presence of a further menu.

• To return to the previous menu, press button 

• To return to the initial screen, press button 

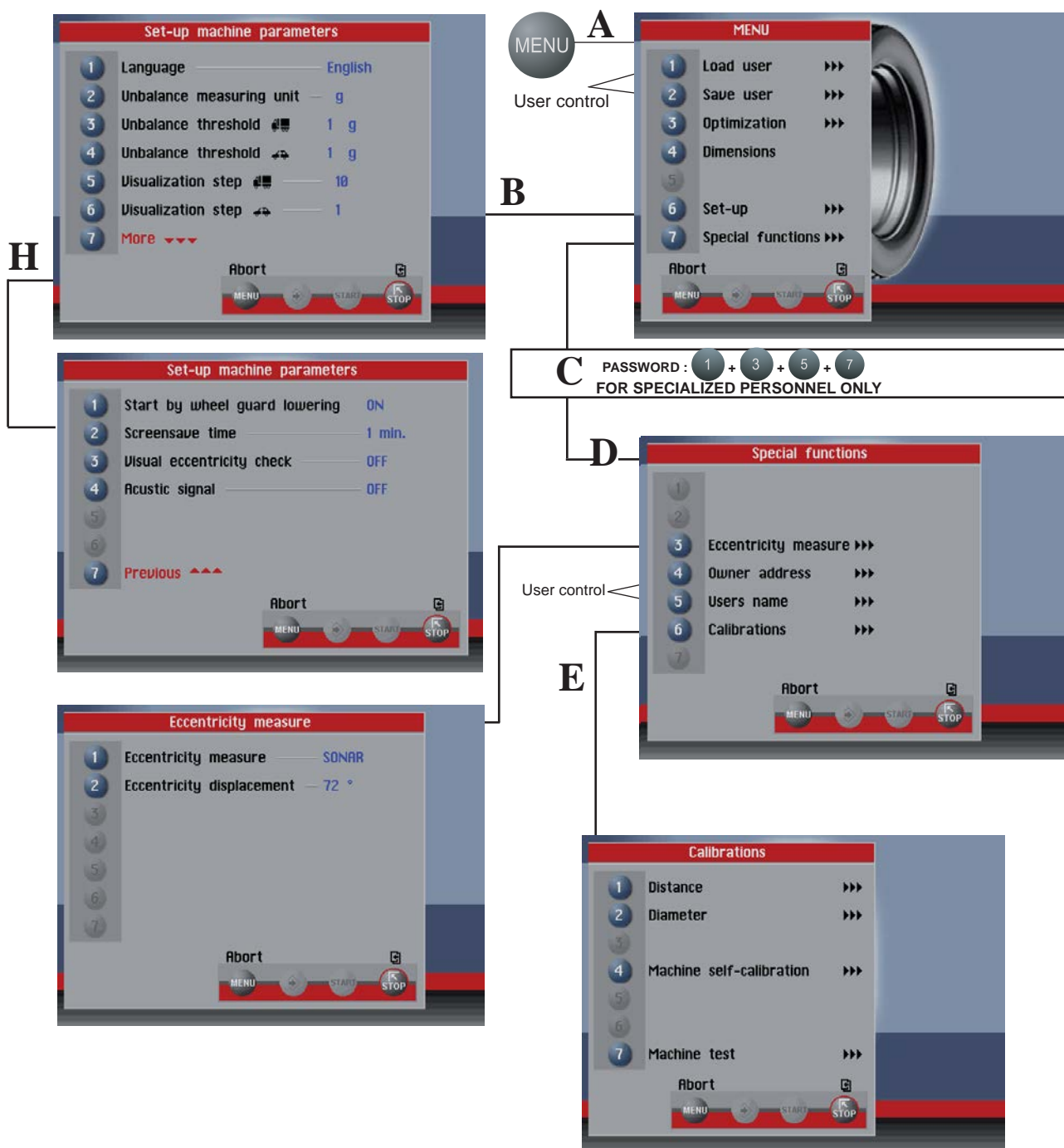



## 6.2 UNBALANCE OPTIMIZATION

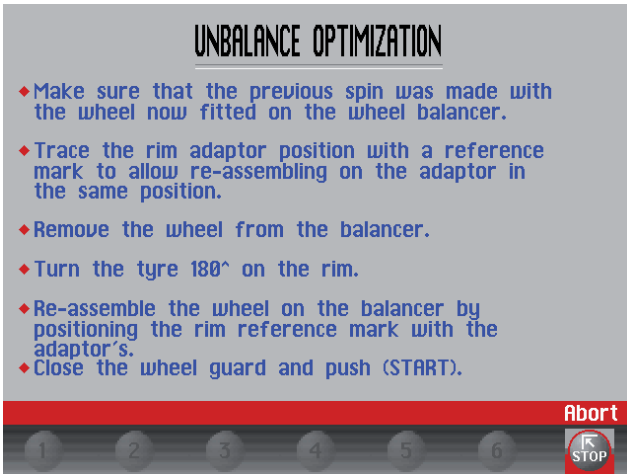

The symbol  is displayed automatically for static unbalance exceeding 30 grams (1.1 oz). The program allows reducing the total unbalance of the wheel by compensating, when possible, the unbalance of the tyre with that of the rim. It requires two spins with rotation of the tyre on the rim in the second spin.

Press  +  after a first spin and follow the instructions appearing on the monitor.



## 7. Setup

The Setup screen provides the user with many possibilities required for presetting the machine according to his own requirements. Such settings remain unaltered even when the machine is switched off.

The following buttons are enabled:

 : return to previous window

 : return to Measurement screen

from  to  : for selection of the parameter.

### 7.1 LANGUAGE

This function allows selecting the language to be used for displaying descriptive and diagnostic messages regarding machine operation.

### 7.2 UNIT OF UNBALANCE MEASUREMENT

It is possible to select whether to display the unbalance values expressed in grams or ounces.

### 7.3 UNBALANCE DISPLAY PITCH

This represents the display pitch of the unbalance and varies according to the unit of measurement selected. The selection "5 g" (1/4 oz) enables display of the correction values on both sides such as to bring the static unbalance to 0 (theoretical). It is recommended to preset this function as standard use of the machine as it improves the balancing quality. The computer makes a complex calculation which allows cancelling the residual static unbalance by varying the value and position of the counterweights fixed in steps of 5 grams (1/4 oz).

### 7.4 UNBALANCE DISPLAY THRESHOLD FOR TRUCK/CAR

This consists of the unbalance threshold below which the wording "OK" appears on the screen at the end of the spin instead of the unbalance; the presettable values vary according to the unit of measurement selected.

### 7.5 UNBALANCE DISPLAY PITCH FOR TRUCK/CAR

This represents the display pitch of the unbalance and varies according to the unit of measurement selected. The selection "5 g" (1/4 oz) for cars and of "50 grams" (1.0 oz.) for trucks enables display of the correction values on both sides such as to bring the static unbalance to 0 (theoretical). It is recommended to preset this function as standard use of the machine as it improves the balan-

cing quality. The computer makes a complex calculation which allows cancelling the residual static unbalance by varying the value and position of the counterweights of fixed value.

### **7.6 SPIN WITH GUARD CLOSED**

When "ON" is selected the automatic start of the spin is enabled when the guard is closed.

### **7.7 SCREEN-SAVER TIME**

If this function is enabled, the screensaver will automatically be activated when the machine is not used for a certain period of time. This function can be disabled by setting it to 0.

### **7.8 VISUAL ECCENTRICITY CHECK**

At the end of wheel acceleration, as soon as the motor is disengaged, the guard can be opened for visual control of any wheel eccentricity as the rotation speed gradually drops. Do not strike the wheel during the entire deceleration stage; to brake the wheel, close the guard. However, avoid using the brake as far as possible because this may compromise unbalance measurements. The unbalance values measured are only displayed when the wheel has come to a standstill. This function is active for only one machine run.

### **7.9 ACOUSTIC SIGNAL**

When "ON" is selected, the sending of an acoustic signal (beep) is enabled in the following cases:

- when any push button is pressed;
- when dimensions are acquired in automatic mode;
- when the correct angular position for weight application is reached in the Measurement screen;
- when the correct angular position for weight application is reached in the Position Repeater screen.

## 8. Special calibrations and functions

In order to gain access to the “Reserved Calibrations and functions” it is necessary to enter a password.

Any incorrect operation within the functions described below could impair the operation of the wheel balancing machine. Unauthorized use will cause cancellation of the warranty on the machine.

### 8.1 CONTROL OF ECCENTRICITY MEASUREMENT

1. Set to ON/OFF to enable/disable tyre eccentricity measurement when starting the unbalance measurement
2. Set the phase shift angle between the eccentricity measurement sonar and the unbalance correction point (top vertical, 12.00 o'clock position)

**Recommended values:** sonar mounted on the guard = 72°.

### 8.2 PRESETTING THE CUSTOMER AND USER NAME

The machine can be customized by presetting:

- a) The name appearing on the Initial screen (screen-save).
- b) The name of 4 different machine users (USER NAME).

An “ideal” keyboard appears on the monitor with the set of characters available for composition of the wordings.

The Customer's name consists of three lines, each max. 30 characters. The USER NAME consists of a wording max. 15 characters.

### 8.3 CALIBRATIONS

When  is pressed from the Special Functions menu, access is gained to the Calibration menu.

#### 8.3.1 Gauge calibration

##### 8.3.1.1 Distance gauge calibration

To calibrate the distance gauge, set it in rest position and then on the adapter plane.

When done, set the gauge in rest position. If calibration is correct, the wheel balancer is ready for operation, otherwise an error message may be displayed if there are errors or malfunctioning; in this case repeat calibration.



to cancel the distance gauge calibration function if has erroneously been accessed.

##### 8.3.1.2 Diameter gauge calibration

To calibrate the diameter gauge, place it on the adapter

flange and press . For better calibration turn the gauge downward and position it 40 mm away from the adapter plane. On the screen a value is shown near the word POS: if it is 256+/- 3°, set the gauge to rest position, otherwise press



to cancel the diameter gauge calibration function if it has erroneously been accessed.

##### 8.3.2 Balancing machine calibration

To calibrate the balancing machine, use a wheel with steel rim of average dimensions, e.g. 6" x 14" (±1").

*To properly perform the procedure:*

- Mount a wheel on the machine, even unbalanced, and very carefully set its dimensions.

#### INDICATION

*Setting incorrect measurements will result in the machine not being correctly calibrated, and balancing of subsequent wheels will hence be incorrect until the machine is recalibrated with the correct measurements!!*

- Follow the on-screen instructions.

### 8.4 WHEEL BALANCING MACHINE SELF TEST

An automatic self-diagnostic cycle is provided for easier trouble-shooting ( Consult the extraordinary maintenance manual or contact Technical Service).

## 9. Diagnostics



### WARNING

THE INFORMATION IN THE **POSSIBLE REMEDY** COLUMN REQUIRES WORK TO BE PERFORMED BY SPECIALIST TECHNICIANS OR OTHER AUTHORISED PEOPLE WHO MUST ALWAYS WORK USING THE **PERSONAL PROTECTIVE EQUIPMENT** INDICATED IN THE **INSTALLATION MANUAL**. IN SOME CASES, THIS WORK CAN BE PERFORMED BY A NORMAL OPERATOR.

ERRORS	CAUSES	CONTROLS
Black	The wheel balancer does not switch on.	<ol style="list-style-type: none"> <li>1. Verify correct connection to the mains.</li> <li>2. Verify and eventually replace the fuses on the power card.</li> <li>3. Verify monitor function.</li> <li>4. Replace the computer board.</li> </ol>
Err. 1	No rotation signal.	<ol style="list-style-type: none"> <li>1. Check in self-diagnostics that the encoder functions properly.</li> <li>2. Replace the phase pick-up board.</li> <li>3. Replace the computer board.</li> </ol>
Err. 2	Speed too low during detection. During unbalance measurement rotation, wheel speed is less than 42 rpm.	<ol style="list-style-type: none"> <li>1. Make sure that a vehicle wheel is mounted on the wheel balancer.</li> <li>2. Check in self-diagnostics that the encoder functions properly</li> <li>3. Disconnect the piezo connectors from the board and do a spin (if no error is detected, replace the piezo sensors).</li> <li>4. Replace the computer board.</li> </ol>
Err. 3	Unbalance too high.	<ol style="list-style-type: none"> <li>1. Verify wheel dimension settings.</li> <li>2. Check detection unit connections.</li> <li>3. Perform machine calibration.</li> <li>4. Mount a wheel with more or less known unbalance (less than 100 grammes) and verify the response of the machine.</li> <li>5. Replace the computer board.</li> </ol>
Err. 4	Rotation in opposite direction. After pressing [START], the wheel starts turning in the opposite direction (anticlockwise).	<ol style="list-style-type: none"> <li>1. Check in self-diagnostics that the encoder functions properly</li> <li>2. Check the bearing/spring of the phase generator</li> </ol>
Err. 5	Guard open The [START] pushbutton was pressed without first closing the guard.	<ol style="list-style-type: none"> <li>1. Reset the error by pressing pushbutton [7]=End.</li> <li>2. Close the guard.</li> <li>3. Verify the function of the protection uSwitch.</li> <li>4. Press the [START] pushbutton.</li> </ol>
Err. 7 / Err. 8	NOVRAM parameter read error	<ol style="list-style-type: none"> <li>1. Repeat machine calibration</li> <li>2. Shut down the machine.</li> <li>3. Wait for a minimum time of ~ 1 Min.</li> <li>4. Re-start the machine and verify correct operation.</li> <li>5. Replace the computer board.</li> </ol>
Err. 9	NOVRAM parameter write error.	Replace the computer board.
Err. 11	Speed too high error. During unbalance measurement rotation, wheel speed is more than 270 rpm.	<ol style="list-style-type: none"> <li>1. Check if there is any damage or dirt on the timing disc.</li> <li>2. Check in self-diagnostics that the encoder functions properly.</li> <li>3. Replace the computer board.</li> </ol>
Err. 12	Unbalance measuring cycle error.	<ol style="list-style-type: none"> <li>1. Check in self-diagnostics that the encoder functions properly</li> <li>2. Verify correct motor operation.</li> <li>3. Replace the computer board.</li> </ol>
Err.13/ Err.14/ Err.15/ Err.16/ Err.17/ Err.18	Unbalance measurement error.	<ol style="list-style-type: none"> <li>1. Check in self-diagnostics that the encoder functions properly</li> <li>2. Check detection unit connections.</li> <li>3. Verify machine earth/ground connection.</li> <li>4. Mount a wheel with more or less known unbalance (less than 100 grammes) and verify the response of the machine.</li> <li>5. Replace the computer board.</li> </ol>

Err. 22	Maximum number of spins possible for the unbalance measurement has been exceeded.	<ol style="list-style-type: none"> <li>1. Check that a vehicle wheel has been mounted on the wheel balancer.</li> <li>2. Check in self-diagnostics that the encoder functions properly</li> <li>3. Replace the computer board.</li> </ol>
Err.40/ Err.41/ Err.42/ Err.43	Eccentricity graph plotting procedure error.	Perform a new eccentricity measurement.
Err.45/ Err.46/ Err.47/ Err.48	Eccentricity graph value display readout error.	Perform a new eccentricity measurement.
Err.50/ Err.51/ Err.52/ Err.53	Eccentricity graph current value cursor plotting procedure error.	Perform a new eccentricity measurement.
Err.54	Sonar readout error. Sonar value readout impossible.	<ol style="list-style-type: none"> <li>1. Position the eccentricity measurement sonar correctly before performing the measurement.</li> <li>2. Check eccentricity sonar connections.</li> <li>3. Check the power supplies on the power board.</li> <li>4. Replace the eccentricity measurement sonar.</li> <li>5. Make sure that the wheel does not halt before completing at least 4/5 revolutions after the first braking impulse.</li> <li>6. Replace the computer board.</li> </ol>
Err.55	Sonar readout error. Sonar values are insufficient for correct measurement of eccentricity.	<ol style="list-style-type: none"> <li>1. Position the eccentricity measurement sonar correctly before performing the measurement.</li> <li>2. Make sure that the wheel does not halt before completing at least 4/5 revolutions after the first braking impulse.</li> <li>3. Mount a wheel of medium dimensions (14"x5 3/4") and perform an eccentricity measurement . If in these conditions error 55 no longer occurs, this means that the wheel inertia causing the problem is such as to halt the wheel before having acquired the minimum number of values necessary for reliable eccentricity measurement.</li> </ol>

# 10. Maintenance

## 10.1 GENERAL



### CAUTION

BEFORE PERFORMING ANY MAINTENANCE OPERATIONS, MAKE SURE THE MACHINE HAS BEEN DISCONNECTED FROM THE MAINS POWER SUPPLY. ALWAYS USE THE PERSONAL PROTECTIVE EQUIPMENT INDICATED IN THE INSTALLATION MANUAL.

### 10.1.1 Introductory notes

This machine has been designed so as not to require routine maintenance, apart from accurate periodic cleaning. It is important to keep the machine perfectly clean in order to prevent dust or impurities from compromising the operation of the balancer.



### WARNING

THE PEOPLE RESPONSIBLE FOR CLEANING THE AREA WHERE THE MACHINE IS INSTALLED MUST WEAR PERSONAL PROTECTIVE EQUIPMENT IN ORDER TO WORK IN SAFETY AND ACCORDING TO THE CURRENT OCCUPATIONAL HEALTH AND SAFETY REGULATIONS.

As extraordinary maintenance must be performed by service staff or, in any case, by specifically authorised and trained people, is not dealt with in this manual.

### 10.1.2 Safety rules

Performing specialist activities on the equipment, particularly if the guards need to be dismantled, exposes people to serious danger due to the presence of potentially live parts.

The rules shown below must be scrupulously followed.

People must always use the Personal Protective Equipment indicated in the Installation Manual. During activities, unauthorised people may not access the equipment and WORK IN PROGRESS signs will be erected in the department in such a way that they are visible from every place of access.

Specialist staff must be authorised and especially trained concerning the dangers that may arise during operation and the correct methods for avoiding them. They must always work with great care and pay full attention.

If, exceptionally, the staff removes the guards to carry out a particular specialist technical maintenance, inspection or repair job, they are required to put them back after work.

After work, staff must make sure that foreign objects, in particular mechanical pieces, tools or devices used during the operative procedure that could cause damage or malfunctions are not left inside the balancer.

For safety, before starting work, maintenance, inspection and repair staff must disconnect all power sources and take all the necessary preventive safety measures.

As well as operating frequencies, the operations described below indicate the qualifications that staff must possess in order to perform the operation.

### 10.1.3 Replacing fuses

Some protection fuses are located on the power board (see wiring diagrams) accessible by dismantling the weight shelf). If fuses require replacement, use ones with an identical current intensity.

### 10.1.4 To replace the driving pulley

The drive pulley is guaranteed by the manufacturer for approximately 20000 runs.

A spare pulley is found inside the base (see photograph).

*If necessary, to replace the pulley, proceed as follows:*

- Remove the head and the weight holder shelf, taking care not to damage the electric wires
- Remove the retaining screw on the pulley in order to replace it.

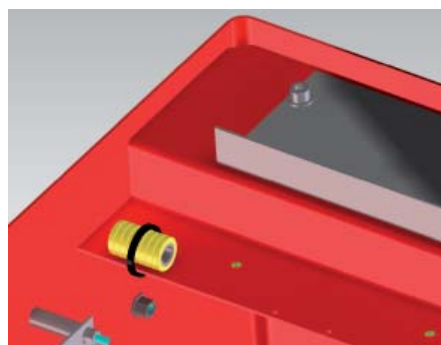

## 11. Disposal



### CAUTION

THE INSTRUCTIONS IN THIS CHAPTER ARE INDICATIVE. REFER TO THE REGULATIONS IN FORCE IN THE COUNTRY WHERE THE EQUIPMENT IS USED.

### 11.1 DISPOSING OF THE BALANCER

The balancer must be disposed of after dismantling the various parts.

For disposal operations, as well as wearing the Personal Protective Equipment indicated in the INSTALLATION MANUAL, refer to the instructions and diagrams in this manual. If necessary, request specific information from the manufacturer.

After dismantling the various parts, sort the various components, separating metal from plastic, from copper, etc., according to the sorted waste disposal regulations in force in the country in which the equipment is dismantled.

If the various components must be stored before being taken to the dump, make sure to keep them in a safe place protected from atmospheric agents in order to prevent them from contaminating the ground and the water table.

### 11.2 DISPOSING OF ELECTRONICS COMPONENTS



Community directive 2002/96/EC, assimilated in Italy with legislative decree n° 151 of 25th July 2005, requires electrical and electronic equipment manufacturers and users to comply with a number of obligations concerning the collection, treatment, recovery and disposal of this waste.

Please scrupulously comply with these waste disposal regulations. Remember that abusive dumping of this waste leads to the application of the administrative penalties established by current law.

## 12. Spare parts

### 12.1 IDENTIFICATION AND ORDERING METHOD

The various parts can be identified using the drawings and diagrams in the machine technical file which is archived by the Manufacturer to which a request can be made.

For off-the-shelf parts, the technical manuals or the supplier's original documents can be provided if the Manufacturer deems this to be useful.

If not supplied, this documentation is also included in the machine Technical File, archived by the Manufacturer, as regards by Ministerial Decree 98/37/EC.

In this case, contact the Technical Service to identify the required piece.

If the required pieces are not in any position or they cannot be identified, contact the Technical Service, specifying the type of machine, its serial number and year of construction.

This information is indicated on the machine identification plate.

## 13. Attached documentation

If not supplied, this documentation is included in the Technical File of the machine, archived by the Manufacturer.

In this case, contact the Technical Service for detailed information concerning the machine.

