

CYCLONE XHE® Model BTH 120 - 250



COMMERCIAL GAS WATER HEATER

**GAS-FIRED POWER BURNER
FOR DOMESTIC HOT WATER**



• INSTALLATION • OPERATION • SERVICE • MAINTENANCE • LIMITED WARRANTY

⚠ WARNING: If the information in these instructions is not followed exactly, a fire or explosion may result causing property damage, personal injury or death.

- Do not store or use gasoline or other flammable vapors and liquids in the vicinity of this or any other appliance.
- **WHAT TO DO IF YOU SMELL GAS:**
 - Do not try to light any appliance.
 - Do not touch any electrical switch; do not use any phone in your building.
 - Immediately call your gas supplier from a neighbor's phone. Follow the gas supplier's instructions.
 - If you cannot reach your gas supplier, call the fire department.
- Installation and service must be performed by a qualified installer, service agency or the gas supplier.

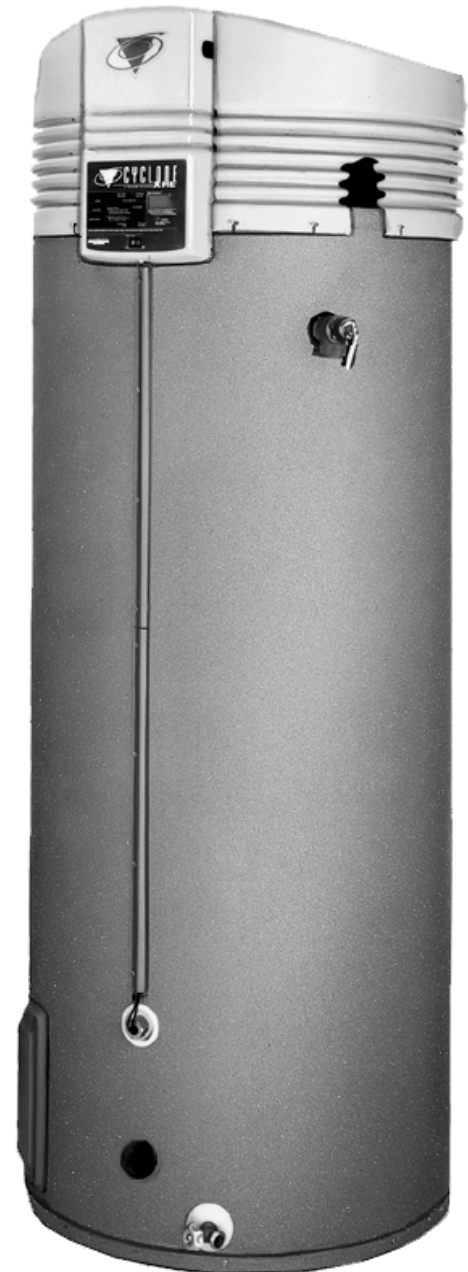

Thank you for buying this energy efficient water heater from A.O. Smith Water Products Company. We appreciate your confidence in our products.

⚠ CAUTION

TEXT PRINTED OR OUTLINED IN RED CONTAINS INFORMATION RELATIVE TO YOUR SAFETY. PLEASE READ THOROUGHLY BEFORE INSTALLING AND USING THIS APPLIANCE.

PLACE THESE INSTRUCTIONS ADJACENT TO HEATER AND NOTIFY OWNER TO KEEP FOR FUTURE REFERENCE.

PRINTED IN U.S.A. 2570 1199

**A.O. SMITH
WATER PRODUCTS
COMPANY**

A DIVISION OF A.O. SMITH CORPORATION
Mc BEE, SOUTH CAROLINA

Part No. 194119-000
Supersedes P/Ns. 192968-000/193329-000/193311-000

ROUGH-IN - DIMENSIONS

CYCLONE XHE BTH 120 - 250

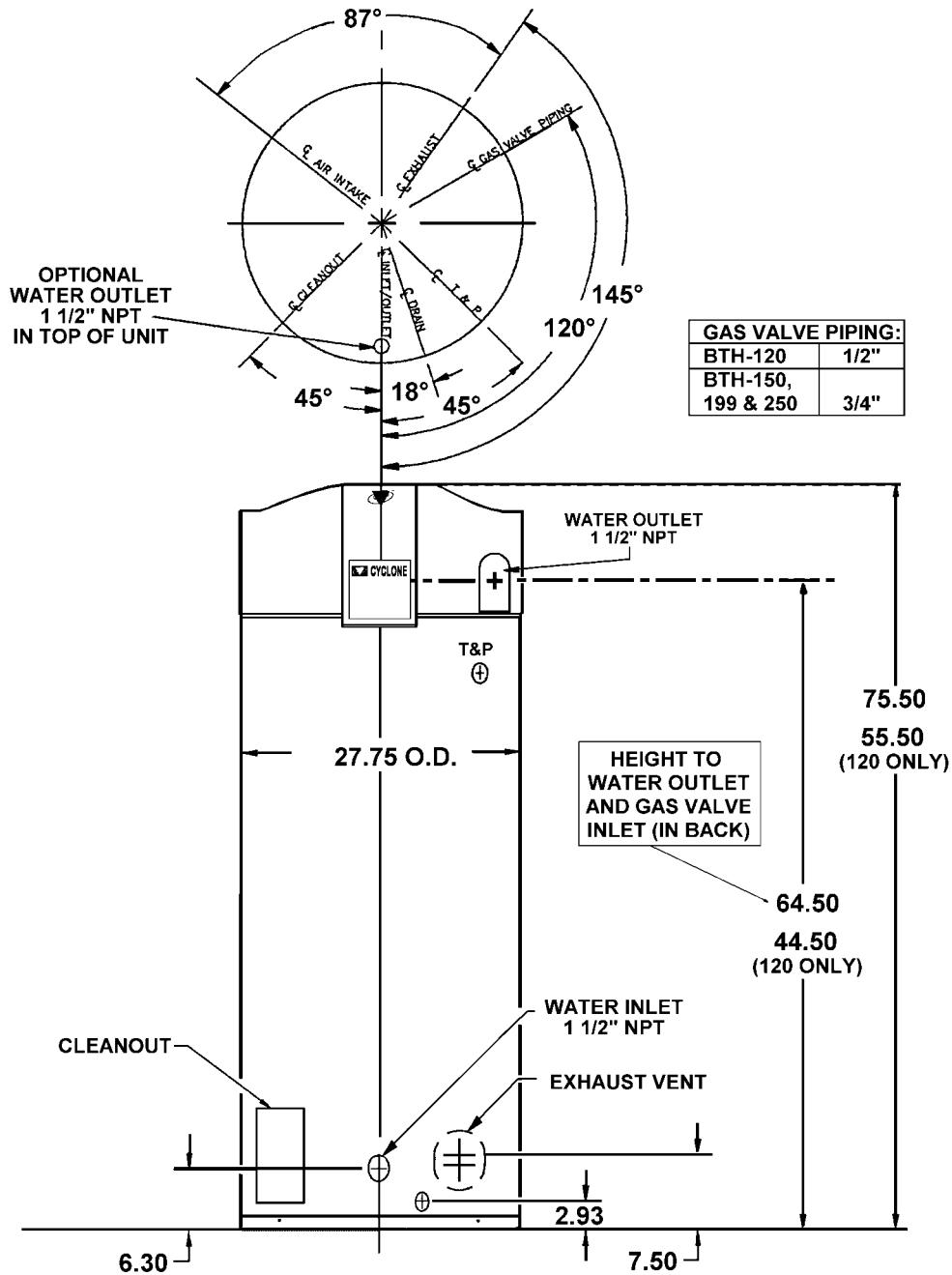

Table 1. RECOVERY CAPACITIES - NATURAL GAS / L.P.

Model	BTU Input	Approx. Gallon Capacity	TEMPERATURE RISE - DEGREES °F - GALLONS PER HOUR											
			30	40	50	60	70	80	90	100	110	120	130	140
BTH - 120	125,000 Nat.	60	475	356	285	237	203	178	158	142	129	119	110	102
BTH - 120	120,000 L.P.	60	456	342	274	228	195	171	152	137	124	114	105	98
BTH - 150	150,000 Nat.	100	570	427	342	285	244	214	190	171	155	142	132	122
BTH - 150	150,000 L.P.	100	570	427	342	285	244	214	190	171	155	142	132	122
BTH - 199	199,900 Nat.	100	759	569	456	380	325	285	253	228	207	190	175	163
BTH - 199	199,900 L.P.	100	759	569	456	380	325	285	253	228	207	190	175	163
BTH - 250	240,000 Nat.	100	912	684	547	456	391	342	304	274	248	228	210	195

Recovery capacities are based on heater performance at 94% thermal efficiency.

FOREWORD

These designs comply with the latest version of the American National Standard for Gas Water Heaters, Volume III, ANSI Z21.10.3 as an automatic circulating tank water heater, and automatic storage water heaters.

Detailed installation diagrams are found in this manual. These diagrams will serve to provide the installer with a reference for the materials and methods of piping necessary. It is highly essential that all water, gas piping and wiring be installed as shown on the diagrams.

Particular attention should be given to the installation of thermometers at the locations indicated on the diagrams as these are necessary for checking the proper functioning of the heater.

In addition to these instructions, the equipment shall be installed in accordance with those installation regulations in force in the local area where the installation is to be made. These shall be carefully followed in all cases. Authorities having jurisdiction should be consulted before installations are made.

In the absence of local codes, the installation must comply with the latest editions of the National Fuel Gas Code, ANSI Z223.1/NFPA 54 and the National Electric Code, NFPA 70. The former is available from the Canadian Standards Association, 8501 East Pleasant Valley Road, Cleveland, OH 44131, and both documents are available from the National Fire Protection Association, 1 Batterymarch Park, Quincy, MA 02269.

TABLE OF CONTENTS

	PAGE		PAGE
ROUGH-IN DIMENSIONS	2	Water Line Connections	14
FOREWORD	3	Heater Wiring	14
FEATURES	4	OPERATION	15
Water Temperature Control	4	Sequence of Operation	15
High Limit Switch (E.C.O.)	4	Self Diagnostic Controller	15
Dishwashing Machine Requirement	5	Gas Valve LEDs Flashing	15
Circulating Pump	5	Error Codes	16
INSTALLATION INSTRUCTIONS	5	Fault Conditions	16
Required Ability	5	No Incoming Line Voltage	16
Insulation Blankets	5	No Low Voltage	16
Locating The Heater	5	Temperature Probe Fault	16
Clearances	6	E.C.O. Switch Open	17
Hard Water	6	Control Bad	17
Air Requirements	6	Combustion Air Blockage	17
Mechanical Exhausting of Room Air	6	PRIOR TO START-UP	18
Unconfined Space	6	Required Ability	18
Confined Space	6	OPERATING INSTRUCTIONS	18
Chemical Vapor Corrosion	6	Adjustment Procedure (Initial Start-Up)	18
VENTING	6	Lighting Instructions	19
Vent Pipe Termination	6	Cathodic Protection	20
Direct Venting	8	Precautions	20
Direct Vent Terminal Installation (Sidewall)	8	GENERAL INFORMATION	20
Installation Sequence	9	Power Burner	20
Vertical Vent Terminal Installation	10	High Limit	20
Installation Sequence	10	High Altitude Installations	20
Installation of Vent System	10-11	MAINTENANCE	20
Vent Pipe Preparation	11	General	20
CONTROLS AND SWITCHES	11-12	Maintenance Schedule	20
Blower Prover Switch	11	Flushing	21
Blocked Outlet Prover Switch	12	Draining	21
Blocked Inlet Prover Switch	12	Sediment Removal	21
Low Gas Pressure Switch	12	Lime Scale Removal	21
On/Off Switch	12	Anode Inspection and Replacement	21-22
Hot Surface Igniter	12	Drain Valve and Access Panels	22
GAS PIPING	12	Relief Valve	22
Connection of Gas Pipe	13	Circulating Pump	22
Purging	13	Vent System	22
Gas Meter Size - City Gases Only	13	INSTALLATION DIAGRAMS	23 - 27
Gas Pressure Regulation	13	Manifold Kits	28
Gas Valves	13	CHECKLIST AND SERVICE INFORMATION	29
SYSTEM CONNECTIONS	13	TROUBLE-SHOOTING	29-30
Thermometers	13	REPLACEMENT PARTS	30
Relief Valve	13	LIMITED WARRANTY	31

FEATURES

IMPORTANT

IT IS REQUIRED THAT A QUALIFIED SERVICE TECHNICIAN PERFORM THE INITIAL FIRING OF THE HEATER. AT THIS TIME THE USER SHOULD NOT HESITATE TO ASK THE TECHNICIAN ANY QUESTIONS WHICH HE MAY HAVE IN REGARD TO THE OPERATION AND MAINTENANCE OF THE UNIT.

A CHECKLIST AND SERVICE INFORMATION section are included at the rear of this manual. By using this checklist the user may be able to make minor operational adjustments and save himself unnecessary service calls. However, the user should not attempt repairs which are not listed in this section.

WATER TEMPERATURE CONTROL

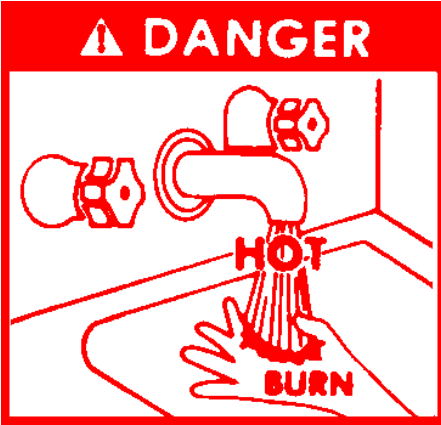

▲ DANGER

THIS WATER HEATER IS EQUIPPED WITH AN ADJUSTABLE THERMOSTAT TO CONTROL WATER TEMPERATURE. HOT WATER TEMPERATURES REQUIRED FOR AUTOMATIC DISHWASHER AND LAUNDRY USE CAN CAUSE SCALD BURNS RESULTING IN SERIOUS PERSONAL INJURY AND/OR DEATH. THE TEMPERATURE AT WHICH INJURY OCCURS VARIES WITH THE PERSON'S AGE AND TIME OF EXPOSURE. THE SLOWER RESPONSE TIME OF DISABLED PERSONS INCREASES THE HAZARDS TO THEM. NEVER ALLOW SMALL CHILDREN TO USE A HOT WATER TAP, OR TO DRAW THEIR OWN BATH WATER. NEVER LEAVE A CHILD OR DISABLED PERSON UNATTENDED IN A BATHTUB OR SHOWER.

THE WATER HEATER SHOULD BE LOCATED IN AN AREA WHERE THE GENERAL PUBLIC DOES NOT HAVE ACCESS TO SET TEMPERATURES.

The water temperature is controlled using the Temperature Control Button on the Display at the front of the unit (See Figure 1). This control utilizes two temperature probes to determine the tank temperature. The primary temperature probe is located at the top of the tank and the other is near the water inlet.

The temperature may be adjusted from 80° to 180°F. The thermostat was adjusted to 120°F before the heater was shipped from the factory. It is recommended that lower water temperatures be used to avoid the risk of scalding. It is further recommended, in all cases, that the water temperature be set for the lowest temperature which satisfies your hot water needs. This will also provide the most energy efficient operation of the water heater and minimize scale formation.

SETTING THE WATER HEATER TEMPERATURE AT 120°F WILL REDUCE THE RISK OF SCALDS. Some states require settings at specific lower temperatures.

Figure 1 shows the approximate time-to-burn relationship for normal adult skin. Short repeated heating cycles caused by small hot water uses can cause temperatures at the point of use to exceed the thermostat setting by up to 20°F. If you experience this type of use, you should consider using lower temperature settings to reduce scald hazards.

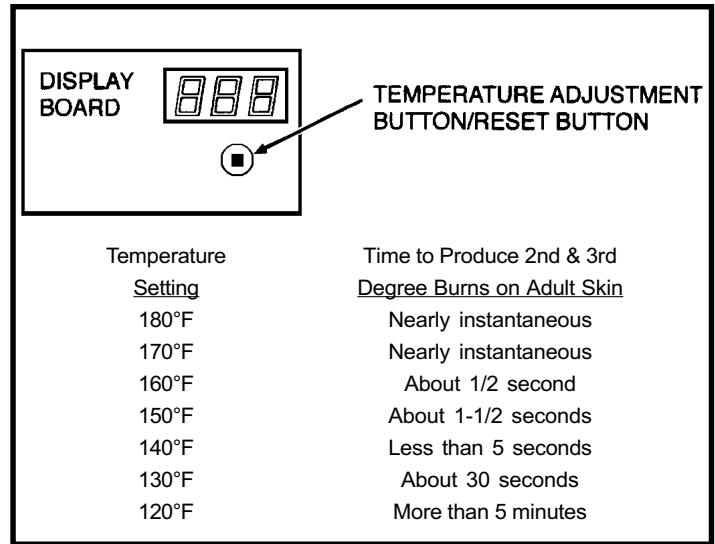

FIGURE 1

Valves for reducing point-of-use temperature by mixing cold and hot water are available (see Figure 2). Also available are inexpensive devices that attach to faucets to limit hot water temperatures. Contact a licensed plumber or the local plumbing authority.

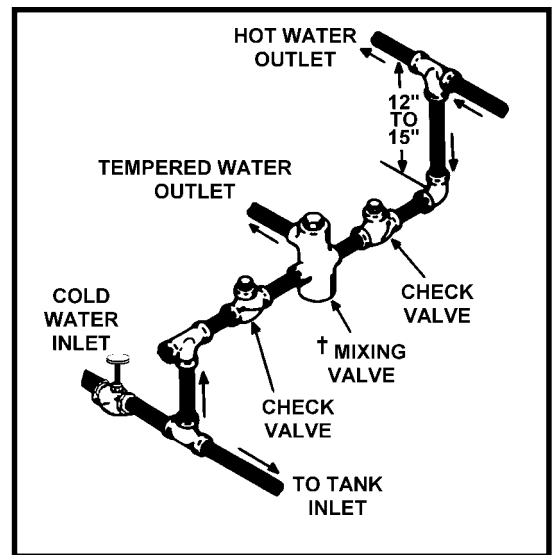

FIGURE 2

HIGH LIMIT SWITCH (E.C.O.)

The top immersion well of the dual bulb controller also contains the high limit (energy cutoff) sensor. The high limit switch interrupts the main burner gas flow should the water temperature reach approximately 202°F.

Should the high limit switch activate, it must be manually reset by depressing the Temperature Adjustment Button/Reset Button on the display board. The water temperature must drop below 160°F before the controller can be reset.

Continued manual resetting of high limit control, preceded by higher than usual water temperature is evidence of high limit switch operation. The following are possible reasons for high limit switch operation.

- A malfunction in the thermostatic controls would allow the gas valve to remain open causing water temperature to exceed the thermostat setting. The water temperature would continue to rise until high limit switch operation.

Contact your dealer or servicer if continued high limit switch operation occurs.

DISHWASHING MACHINE REQUIREMENT

All dishwashing machines meeting the National Sanitation Foundation requirements are designed to operate with water flow pressures between 15 and 25 pounds per square inch. Flow pressures above 25 pounds per square inch, or below 15 pounds per square inch, will result in improperly sanitized dishes. Where pressures are high, a water pressure reducing or flow regulating control valve should be used in the 180°F line to the dishwashing machine, and should be adjusted to deliver water between these limits.

The National Sanitation Foundation also recommends circulation of 180°F water. Where this is done, the circulation should be very gentle so that it does not cause any unnecessary turbulence inside the water heater. The circulation should be just enough to provide 180°F water at the point of take-off to the dishwashing machine. Adjust flow by means of the plug cock in the circulating line. (See installation diagrams.)

CIRCULATING PUMP

A circulating pump is used when a system requires a circulating loop or there is a storage tank used in conjunction with the heater. Refer to the piping diagrams at rear of manual for electrical hookup information and install in accordance with the latest version of the National Electric Code ANSI/NFPA No. 70.

Only all bronze circulators are used with commercial water heaters.

Although circulators are oiled and operated by the manufacturer some circulators must be oiled again before operated. Please refer to manufacturer's instructions.

INSTALLATION INSTRUCTIONS

REQUIRED ABILITY

INSTALLATION OR SERVICE OF THIS WATER HEATER REQUIRES ABILITY EQUIVALENT TO THAT OF A LICENSED TRADESMAN IN THE FIELD INVOLVED. PLUMBING, AIR SUPPLY, VENTING, GAS SUPPLY AND ELECTRICAL WORK ARE REQUIRED.

INSULATION BLANKETS

Insulation blankets available to the general public for external use on gas water heaters are not approved for use on your A.O. Smith water heater. The purpose of an insulation blanket is to reduce the standby heat loss encountered with storage tank water heaters. Your A.O. Smith water heater meets or exceeds the ASHRAE/IES 90.1b 1992 standards with respect to insulation and standby loss requirements, making an insulation blanket unnecessary.

WARNING

Should you choose to apply an insulation blanket to this heater, you should follow these instructions. Failure to follow these instructions can result in fire, asphyxiation, serious personal injury or death.

- Do not apply insulation to the top, or the upper 15" of the water heater, as this will interfere with safe operation.
- Do not cover the temperature & pressure relief valve.
- Do not cover the instruction manual. Keep it on the side of the water heater or nearby for future reference.
- Do obtain new labels from A.O. Smith for placement on the blanket directly over the existing labels.

LOCATING THE HEATER

WARNING

THERE IS A RISK IN USING FUEL BURNING APPLIANCES SUCH AS GAS WATER HEATERS IN ROOMS, GARAGES OR OTHER AREAS WHERE GASOLINE, OTHER FLAMMABLE LIQUIDS OR ENGINE DRIVEN EQUIPMENT OR VEHICLES ARE STORED, OPERATED OR REPAIRED. FLAMMABLE VAPORS ARE HEAVY AND TRAVEL ALONG THE FLOOR AND MAY BE IGNITED BY THE HEATER'S IGNITER OR MAIN BURNER FLAMES CAUSING FIRE OR EXPLOSION. SOME LOCAL CODES PERMIT OPERATION OF GAS APPLIANCES IF INSTALLED 18 INCHES OR MORE ABOVE THE FLOOR. THIS MAY REDUCE THE RISK IF LOCATION IN SUCH AN AREA CANNOT BE AVOIDED.

THE HEATER SHALL BE LOCATED OR PROTECTED SO IT IS NOT SUBJECT TO PHYSICAL DAMAGE BY A MOVING VEHICLE.

DO NOT LOCATE THE HEATER WHERE NOISE FROM THE EXHAUST OR INTAKE WILL BE OBJECTIONABLE. THIS INCLUDES LOCATIONS CLOSE TO OR ACROSS FROM WINDOWS AND DOORS. AVOID ANCHORING THE VENT AND INTAKE PIPES DIRECTLY TO FRAMED WALLS, FLOORS OR CEILINGS UNLESS RUBBER ISOLATION PIPE HANGERS ARE USED. THIS PREVENTS ANY VIBRATIONS FROM BEING TRANSMITTED INTO THE LIVING SPACES.

WARNING

FLAMMABLE ITEMS, PRESSURIZED CONTAINERS OR ANY OTHER POTENTIAL FIRE HAZARDOUS ARTICLES MUST NEVER BE PLACED ON OR ADJACENT TO THE HEATER. OPEN CONTAINERS OF FLAMMABLE MATERIAL SHOULD NOT BE STORED OR USED IN THE SAME ROOM WITH THE HEATER.

When installing the heater, consideration must be given to proper location. Location selected should be as close to the intake and exhaust termination points as practicable, with adequate air supply and as centralized with the piping system as possible.

THE HEATER MUST NOT BE LOCATED IN AN AREA WHERE IT WILL BE SUBJECT TO FREEZING.

LOCATE IT NEAR A FLOOR DRAIN. THE HEATER SHOULD BE LOCATED IN AN AREA WHERE LEAKAGE FROM THE HEATER OR CONNECTIONS WILL NOT RESULT IN DAMAGE TO THE ADJACENT AREA OR TO LOWER FLOORS OF THE STRUCTURE.

When such locations cannot be avoided, it is recommended that a suitable drain pan, adequately drained, be installed under the appliance.

WARNING

THIS WATER HEATER IS A CONDENSING UNIT AND REQUIRES A DRAIN TO BE LOCATED IN CLOSE PROXIMITY TO ALLOW THE CONDENSATE TO DRAIN SAFELY. THE CONDENSATE DRAINS FROM THE UNIT AT THE EXHAUST ELBOW LOCATED AT THE BOTTOM OF THE UNIT. NOTE: IT IS IMPORTANT THAT THE CONDENSATE HOSE NOT BE ELEVATED ABOVE THE EXHAUST ELBOW (SEE FIGURE 3). THE CONDENSATE BUILD-UP WILL BLOCK THE EXHAUST OUTLET, WHICH WILL CAUSE IMPROPER OPERATION.

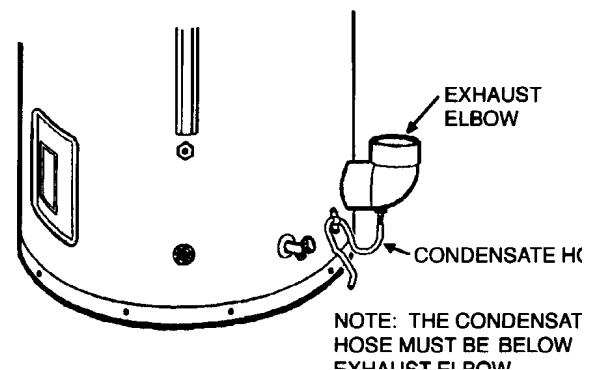

FIGURE 3

⚠ WARNING

DO NOT USE THIS APPLIANCE IF ANY PART HAS BEEN UNDER WATER. IMMEDIATELY CALL A QUALIFIED SERVICE TECHNICIAN TO INSPECT THE APPLIANCE AND TO REPLACE ANY PART OF THE CONTROL SYSTEM AND ANY GAS CONTROL WHICH HAS BEEN UNDER WATER.

CLEARANCES

These heaters are approved for installation on combustible flooring in an alcove when the minimum clearances from any combustion construction are followed as indicated in Figure 4.

In all installations the minimum combustible clearances from any vent piping shall be 0". Vent piping passing through a combustible wall or ceiling must be a continuous run (no joints).

A service clearance of 24" should be maintained from serviceable parts such as relief valves, flue baffles, flue damper devices, thermostats, cleanout openings or drain valves.

Always disconnect electrical power before servicing the unit

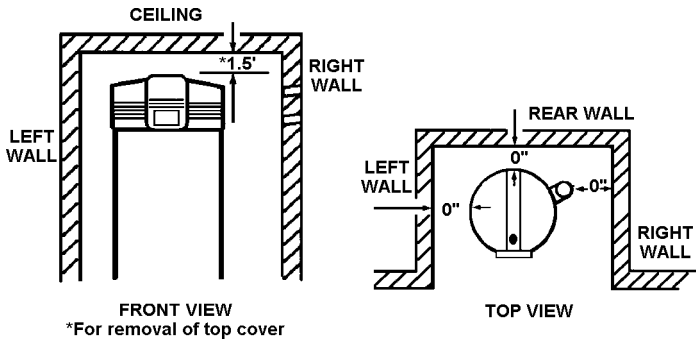

FIGURE 4

*ILLUSTRATION OF MINIMUM COMBUSTIBLE CLEARANCES IN AN ALCOVE

HARD WATER

Where hard water conditions exist, water softening or the threshold type of water treatment is recommended. This will protect the dishwashers, coffee urns, water heaters, water piping and other equipment.

See MAINTENANCE section for details of tank cleanout procedure.

AIR REQUIREMENTS

KEEP APPLIANCE AREA CLEAR AND FREE OF COMBUSTIBLE MATERIALS, GASOLINE AND OTHER FLAMMABLE VAPORS AND LIQUIDS.

DO NOT OBSTRUCT THE FLOW OF COMBUSTION AND VENTILATING AIR.

⚠ WARNING

FOR SAFE OPERATION PROVIDE ADEQUATE AIR FOR COMBUSTION AND VENTILATION. AN INSUFFICIENT SUPPLY OF AIR WILL CAUSE RECIRCULATION OF COMBUSTION PRODUCTS RESULTING IN CONTAMINATION THAT MAY BE HAZARDOUS TO LIFE. SUCH A CONDITION OFTEN WILL RESULT IN A YELLOW, LUMINOUS BURNER FLAME, CAUSING CARBONING OR SOOTING OF THE COMBUSTION CHAMBER, BURNERS AND FLUE TUBES AND CREATES A RISK OF ASPHYXIATION.

MECHANICAL EXHAUSTING OF ROOM AIR

Where an exhaust fan is installed in the same room with a heater, sufficient openings for air must be provided in the walls. **UNDERSIZED OPENINGS WILL CAUSE AIR TO BE DRAWN INTO THE ROOM THROUGH THE HEATER'S VENTING SYSTEM, CAUSING POOR COMBUSTION. SOOTING MAY RESULT IN SERIOUS DAMAGE TO THE HEATER AND RISK OF FIRE OR EXPLOSION. IT CAN ALSO CREATE A RISK OF ASPHYXIATION.**

UNCONFINED SPACE

In buildings of conventional frame, brick or stone construction, unconfined spaces may provide adequate air for combustion and ventilation.

If the unconfined space is within a building of tight construction (buildings using the following construction: weather stripping, heavy insulation, caulking, vapor barrier, etc.), air for combustion and ventilation must be obtained from outdoors. The installation instructions for confined spaces in tightly constructed buildings must be followed to ensure adequate air supply.

CONFINED SPACE

When drawing combustion air from inside a conventionally constructed building to a confined space, such a space shall be provided with two permanent openings, ONE IN OR WITHIN 12 INCHES OF THE ENCLOSURE TOP AND ONE IN OR WITHIN 12 INCHES OF THE ENCLOSURE BOTTOM. Each opening shall have a free area of at least one square inch per 1000 Btuh of the total input of all appliances in the enclosure, but not less than 100 square inches.

If the confined space is within a building of tight construction, air for combustion and ventilation must be obtained from outdoors. When directly communicating with the outdoors through vertical ducts, two permanent openings, located in the above manner, shall be provided. Each opening shall have a free area of not less than one square inch per 4000 Btuh of the total input of all appliances in the enclosure. If horizontal ducts are used, each opening shall have a free area of not less than one square inch per 2000 Btuh of the total input of all appliances in the enclosure.

CHEMICAL VAPOR CORROSION

⚠ WARNING

CORROSION OF THE FLUE WAYS AND VENT SYSTEM MAY OCCUR IF AIR FOR COMBUSTION CONTAINS CERTAIN CHEMICAL VAPORS. SUCH CORROSION MAY RESULT IN FAILURE AND RISK OF ASPHYXIATION.

Spray can propellants, cleaning solvents, refrigerator and air conditioning refrigerants, swimming pool chemicals, calcium and sodium chloride, waxes, and process chemicals are typical compounds which are potentially corrosive.

PRODUCTS OF THIS SORT SHOULD NOT BE STORED NEAR THE HEATER. ALSO, AIR WHICH IS BROUGHT IN CONTACT WITH THE HEATER SHOULD NOT CONTAIN ANY OF THESE CHEMICALS. IF NECESSARY, UNCONTAMINATED AIR SHOULD BE OBTAINED FROM REMOTE OR OUTSIDE SOURCES.

VENTING

⚠ WARNING

THE INSTRUCTIONS IN THIS SECTION ON VENTING MUST BE FOLLOWED TO AVOID CHOKED COMBUSTION OR RECIRCULATION OF FLUE GASES. SUCH CONDITIONS CAUSE SOOTING OR RISKS OF FIRE AND ASPHYXIATION.

Heater must be protected from freezing downdrafts during shutdown periods.

⚠ WARNING

NEVER OPERATE THE HEATER UNLESS IT IS VENTED TO THE OUTDOORS AND HAS ADEQUATE AIR SUPPLY TO AVOID RISKS OF IMPROPER OPERATION, FIRE, EXPLOSION OR ASPHYXIATION.

VENT PIPE TERMINATION

NOTE: Before installing venting, determine place of vent pipe termination. See Figure 6 before proceeding.

⚠ CAUTION

DO NOT TERMINATE THE VENTING WHERE NOISE FROM THE EXHAUST OR INTAKE WILL BE OBJECTIONABLE. THIS INCLUDES LOCATIONS CLOSE TO OR ACROSS FROM WINDOWS AND DOORS. AVOID ANCHORING THE VENT AND INTAKE PIPES DIRECTLY TO FRAMED WALLS, FLOORS OR CEILINGS UNLESS RUBBER ISOLATION PIPE HANGERS ARE USED. THIS PREVENTS ANY VIBRATIONS FROM BEING TRANSMITTED INTO THE LIVING SPACES.

DIRECT VENT

⚠ WARNING
VENT HOOD(S) MAY
BE EXTREMELY HOT
DURING OPERATION

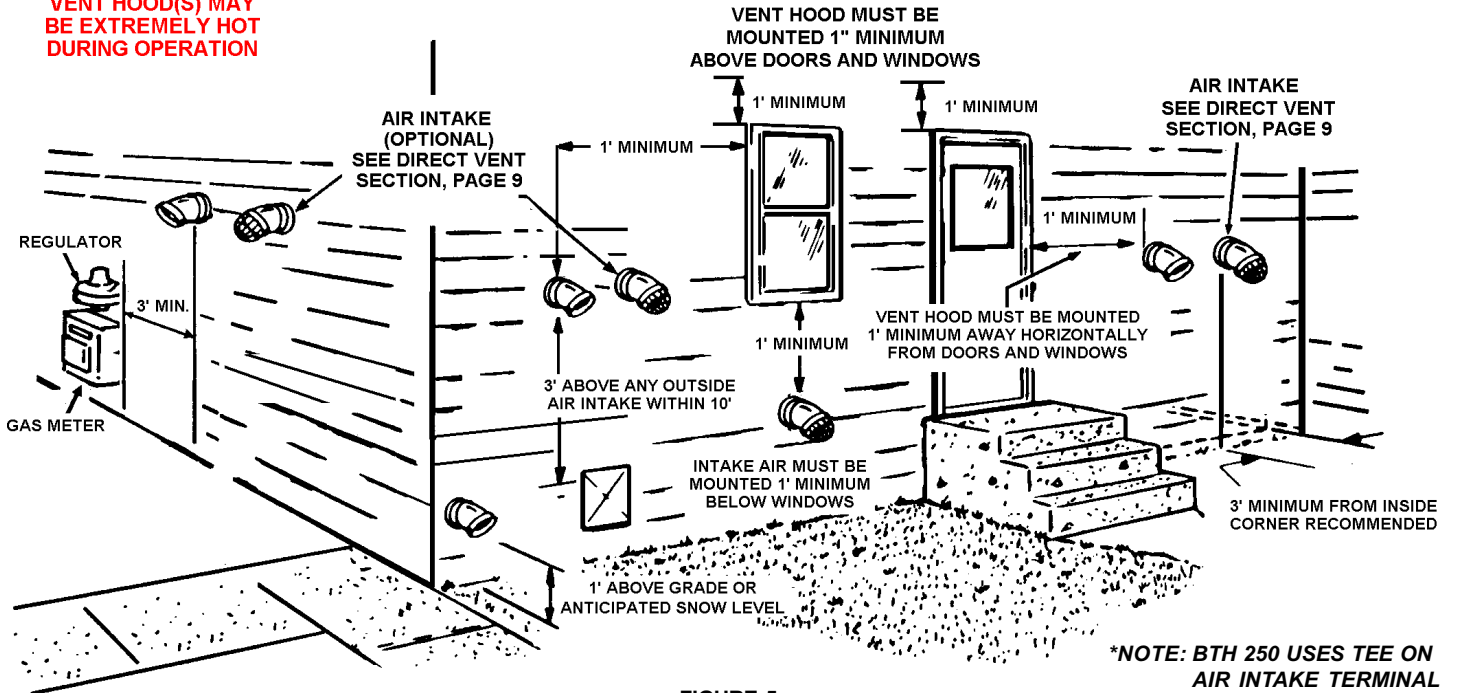

FIGURE 5

DO NOT TERMINATE EXHAUST OVER PUBLIC AREA WHERE CONDENSATE OR VAPOR CAN CAUSE NUISANCE OR HAZARD.

EXHAUST VENT HOOD MUST BE LOCATED 1' MINIMUM FROM ANY OPENING IN BUILDING.

HORIZONTAL VENT

⚠ WARNING
VENT HOOD(S) MAY
BE EXTREMELY HOT
DURING OPERATION

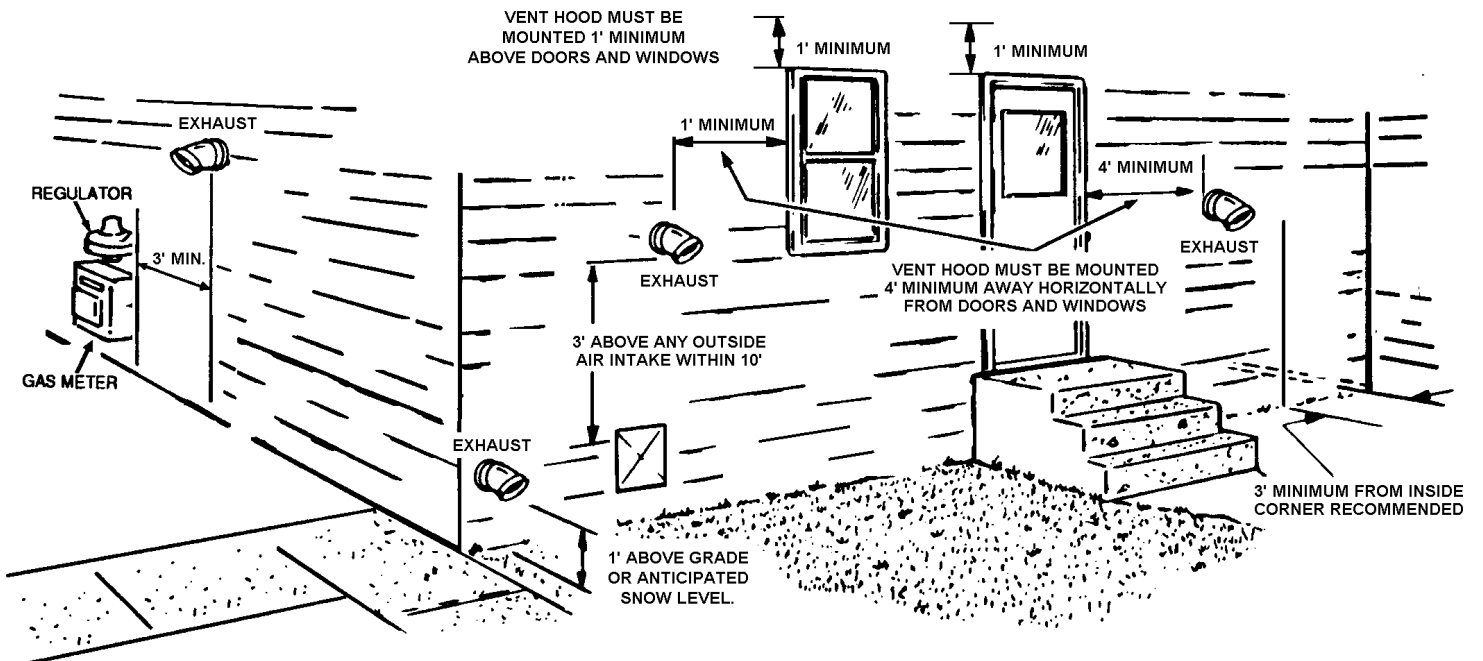

FIGURE 6

IMPORTANT

The vent system must terminate so that proper clearances are maintained as cited in local codes or the latest edition of the National Fuel Gas Code, ANSI Z223.1, 7.3.4e and 7.8a,b, as follows:

1. Do not terminate the exhaust vent terminal over public area where condensate or vapor can cause nuisance or hazard.
2. For direct vent, the venting system shall terminate at least 1 foot below, 1 foot horizontally from or 1 foot above any door, window, or gravity air inlet into building.
3. For horizontal the venting system shall terminate 4 foot below, 4 foot horizontally from or 1 foot above any door, window, or gravity air inlet into building.
4. The manufacturer also recommends the vent system terminations not be installed closer than 3 feet from an inside corner of an L shaped structure. And not less than 1 foot above grade or anticipated snow level.
5. The vent termination shall not be mounted directly above or within 3 feet horizontally from an oil tank vent or gas meter to avoid potential freeze-up from condensation.
6. The vent shall terminate a minimum of 12" above expected snowfall level to prevent blockage of vent termination.

Plan the vent system layout so that proper clearances are maintained from plumbing and wiring.

Vent pipes serving power vented appliances are classified by building codes as "vent connectors". Required clearances from combustible materials must be provided in accordance with information in this manual under LOCATION OF HEATER and CLEARANCES, and with National Fuel Gas Code and local Codes.

IMPORTANT

Plan the layout of the vent system backwards from the vent termination to the appliance.



WARNING

USE ONLY THE VENT TERMINALS SUPPLIED WITH THIS UNIT. TERMINATION OF A VENT SYSTEM WITH A DEVICE OTHER THAN THE SUPPLIED VENT TERMINATIONS WILL AFFECT SYSTEM PERFORMANCE AND RESULT IN A SAFETY HAZARD.

DIRECT VENTING

The air intake provided on the unit contains a mesh screen (see Figure 7) to prevent large particles from entering the unit.

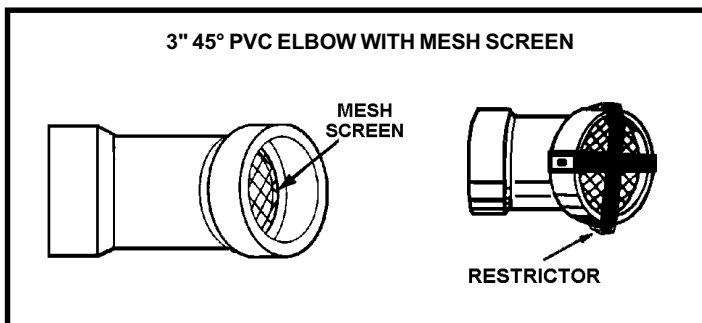

FIGURE 7



WARNING

WHEN THE UNIT IS TO BE SETUP AS A DIRECT VENT, THE MESH SCREEN MUST BE REMOVED. THE INLET VENT PIPE MAY THEN BE GLUED TO THE AIR INTAKE (see Figure 8) PROVIDED ON THE UNIT.

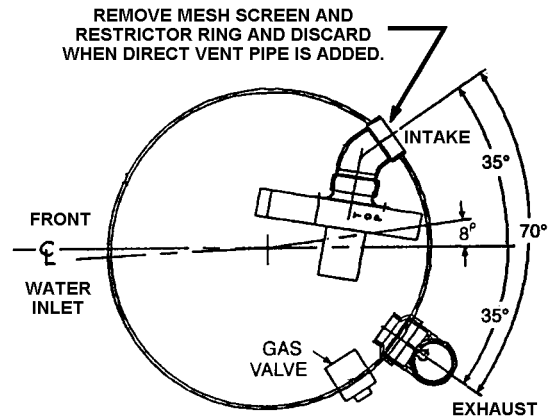

FIGURE 8

DIRECT VENT TERMINAL INSTALLATION

IMPORTANT

THIS UNIT CONSISTS OF TWO VENT TERMINALS - AN INTAKE VENT TERMINAL AND AN EXHAUST VENT TERMINAL. THE INTAKE VENT TERMINAL IS A 3" 45° PVC ELBOW (OR 3" PVC TEE FOR BTH 250) WITH A MESH WIRE SCREEN AND THE EXHAUST VENT TERMINAL IS A 3" 45° PVC ELBOW WITH A MESH WIRE SCREEN.

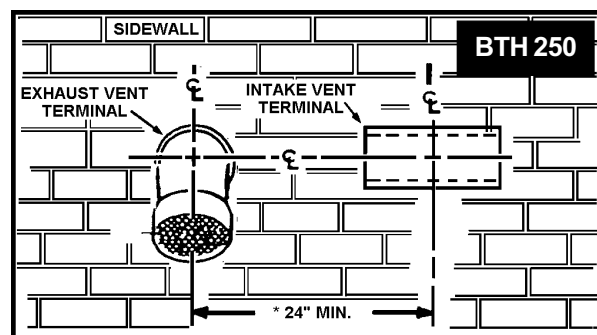
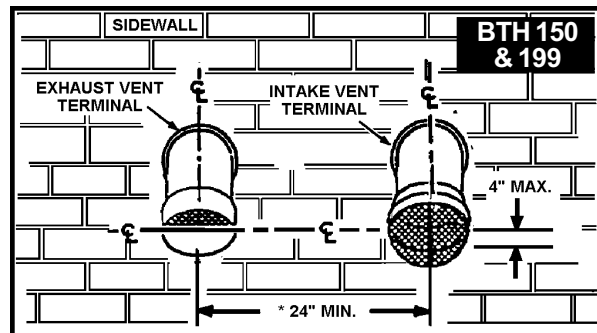
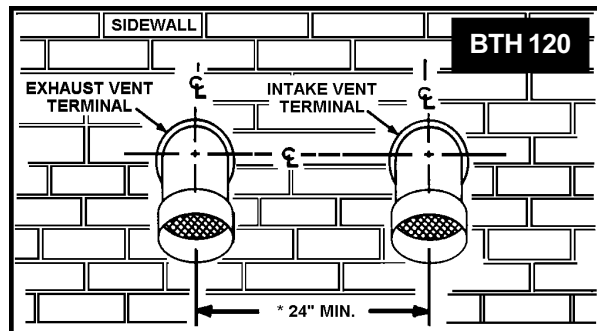

FIGURE 9

IMPORTANT

WHEN LOCATING THE TERMINALS ON A SIDEWALL, THE FOLLOWING SPECIFICATIONS PERTAINING TO TERMINAL LOCATION MUST BE FOLLOWED.

1. The intake vent terminal and the exhaust vent terminal must terminate on the same exterior wall and must be located at a minimum of 24" (inches) from the vertical centerline of the exhaust vent terminal (see Figure 9). In colder climates increasing the 24" minimum will reduce possibility of frost over from side winds blowing exhaust vapors to the air intake of the direct the vent.
2. The horizontal centerline of the intake vent terminal may not be located lower than the horizontal centerline of the exhaust vent terminal (see Figure 9).

INSTALLATION SEQUENCE

For installations in the City of Los Angeles, California Category IV PVC Pipe such as that manufactured by Brownline Pipe Company, must be used as vent pipe material



Vent terminals supplied with the heater must be used.

NOTE: BEFORE BEGINNING INSTALLATION OF ANY VENT PIPE READ THE VENT PIPE MANUFACTURER'S INSTALLATION INSTRUCTIONS.

1. After the points of termination have been determined, use the cover plates as templates to mark the holes for the vent pipes to be inserted through the wall. BEWARE OF CONCEALED WIRING AND PIPING INSIDE OF WALL.
2. If the vent terminals are being installed on the outside of a finished wall, it may be easier to mark both the inside and outside wall. Align the holes by drilling a hole through the center of the template from the inside through to the outside. The template can now be positioned on the outside wall using the drilled holes as a centering point for the template.
3. A) MASONRY SIDE WALLS
Chisel an opening approximately one half inch larger than the marked circle.

B) WOODEN SIDE WALLS
Drill a pilot hole approximately one quarter inch outside of the marked circle. This pilot hole is used as a starting point for a saws-all or sabre saw blade. Cut around the marked circle staying approximately one quarter inch outside of the line. (This will allow the vent pipe to easily slide through the opening. The resulting gap will be covered by the vent terminal cover plates.) Repeat this step on the inside wall if necessary.
4. Cut a length of 3 inch PVC pipe about 3.5 inches longer than the wall thickness at the opening.
5. Glue the intake vent terminal to the section of the pipe.
6. Slide the wall plate over the pipe to stop against intake vent terminal.
7. Place a bead of caulking (not supplied) around the gap between the pipe and the wall. Place some of the caulking on the back of the plate to hold it against the wall after installation.
8. If the vent pipe is installed up to the wall, with a coupling on the end against the wall opening, the pipe with the vent terminal can be prepared for gluing before inserting through the wall. Slide the pipe through the wall and insert into coupling on the other side of the wall, making sure that the vent terminal ends up pointed in the correct position (Figure 10).

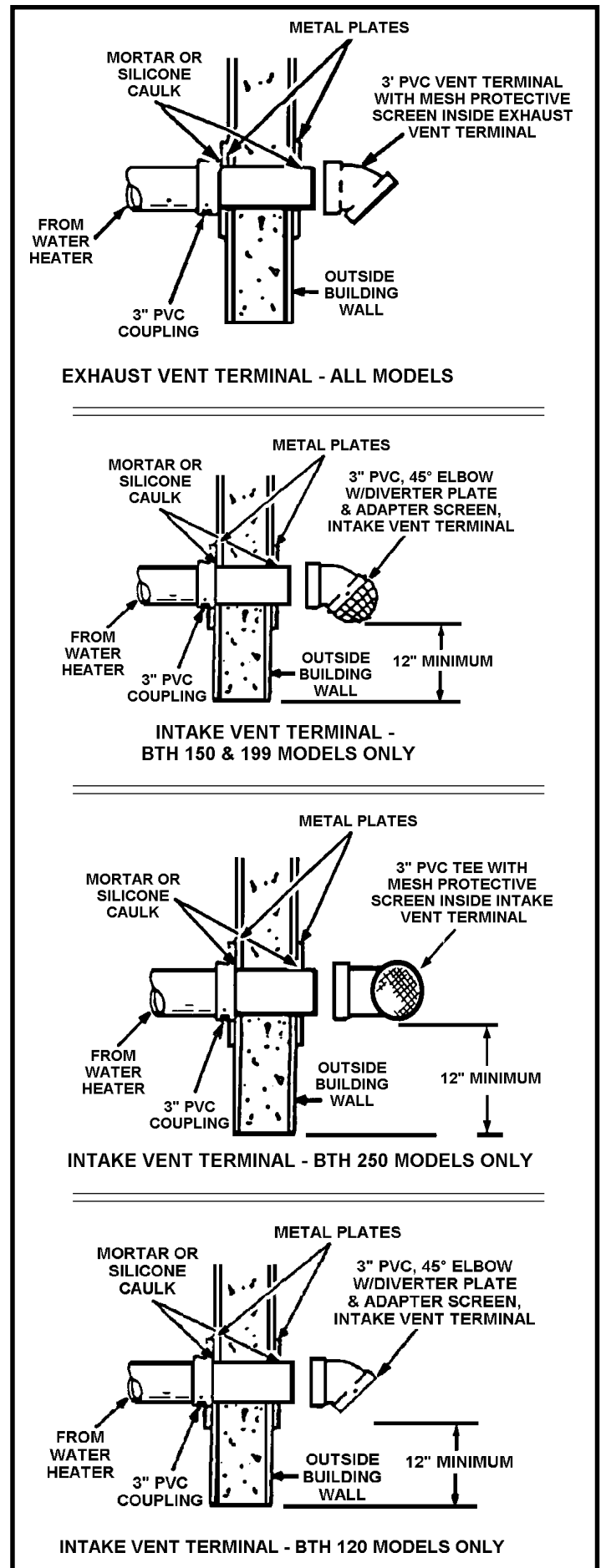

FIGURE 10

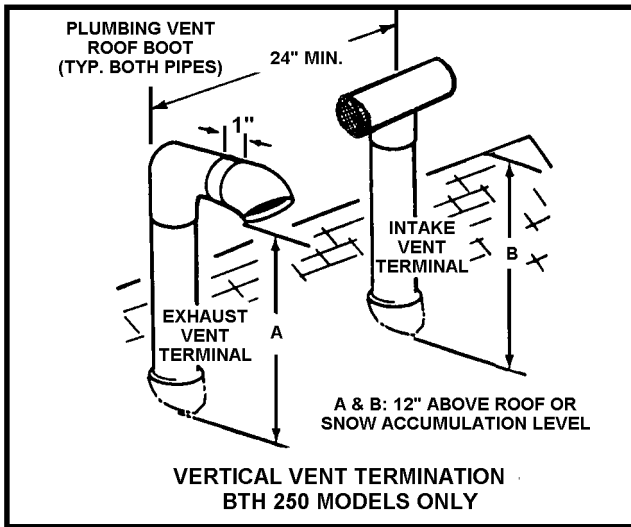

FIGURE 11

VERTICAL VENT TERMINAL INSTALLATION IMPORTANT

WHEN TERMINATING THROUGH A ROOF, THE FOLLOWING SPECIFICATIONS PERTAINING TO TERMINAL LOCATION MUST BE FOLLOWED.

1. Proper support must be provided for all pipe protruding through the roof.
2. The vertical roof terminations should be sealed with a plumbing roof boot or equivalent flashing.
3. The intake vent termination and the exhaust vent termination must penetrate the same side of roof.
4. The center line of the intake vent termination and the center line of the exhaust vent termination must be no closer than 24" (inches).
5. The intake vent terminal and the exhaust vent terminal must be oriented facing downward and the same direction.

The specifications are displayed in Figure 11 & 12.

NOTE: Exhaust vent terminal is installed using the same procedure.

INSTALLATION SEQUENCE

NOTE: BEFORE BEGINNING INSTALLATION OF ANY VENT PIPE, READ "VENT PIPE PREPARATION" SECTION ON PAGE 11.

1. After the points of termination have been determined, use the cover plates as templates to mark the holes for the vent pipes to be inserted through the roof.
2. Drill a pilot hole approximately one quarter inch outside of the marked circle. This pilot hole is used as a starting point for a saws-all or sabre saw blade. Cut around the marked circle staying approximately one quarter inch outside the line. (This will allow the vent pipe to easily slide through the opening). The resulting gap will be covered by the roof boot/ flashing.
3. Suspend the pipe through the center of the hole using proper support.
4. Slide roof boot or equivalent flashing over pipe and secure roof boot equivalent flashing to roof.
5. Seal around flashing.
6. Terminate intake terminal and exhaust vent terminal facing down as shown in Figure 12.

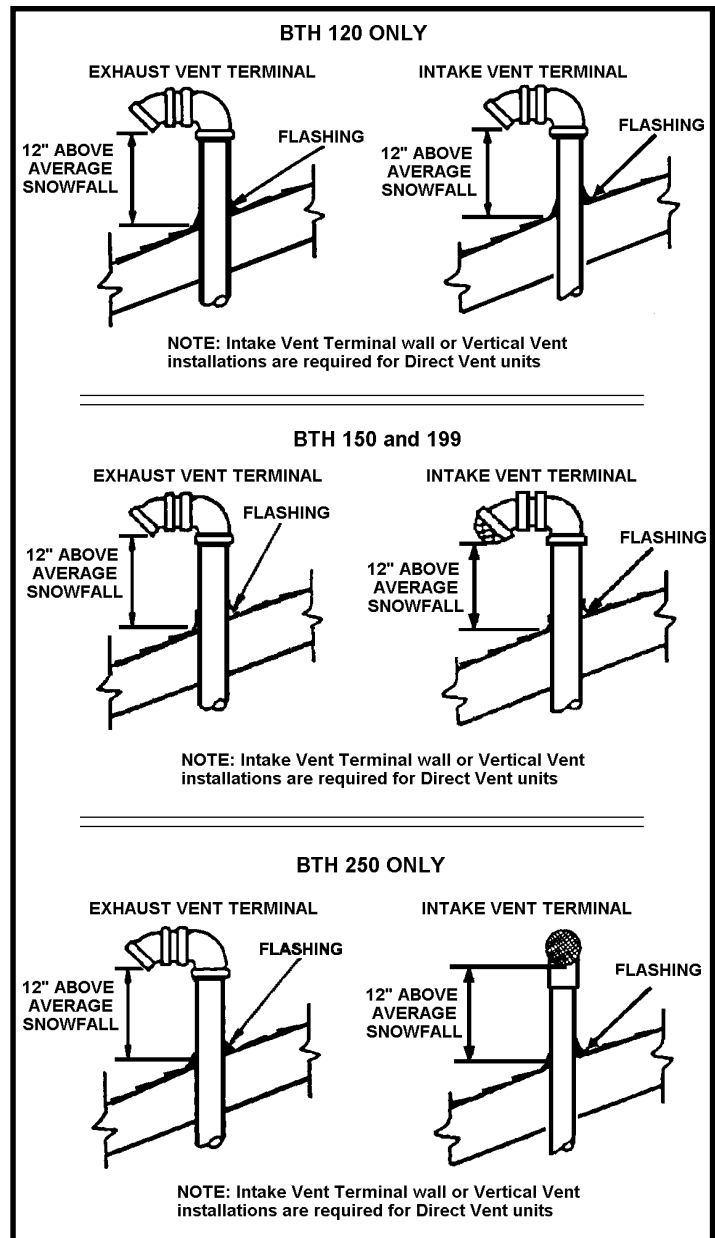

FIGURE 12

INSTALLATION OF VENT SYSTEM

⚠ WARNING

THE OPTIONAL INTAKE VENTING ARRANGEMENT AND THE EXHAUST VENTING ARRANGEMENT MUST BE INSTALLED TO RUN DIRECTLY TO THE OUTDOORS AND NOT IN ANY WAY BE CONNECTED TO ANOTHER VENTING SYSTEM (I.E. FURNACE, DRYERS OR SPACE HEATERS). IT IS CRUCIAL THAT THE VENTING ARRANGEMENT BE KEPT SEPARATE FROM OTHER VENTING SYSTEMS. IF THIS WARNING IS IGNORED, AND THE SYSTEM IS VENTED INCORRECTLY, IT MAY CAUSE IMPROPER OPERATION, FIRE, EXPLOSION, OR ASPHYXIATION.

1. Plan the route of the vent system from the vent termination to the planned location of the appliance. Layout the total vent system to use the minimum of vent pipe and elbows possible.
2. The installer may add up to a MAXIMUM OF FIFTY (50) EQUIVALENT feet of pipe to the exhaust venting arrangement. This addition of FIFTY (50) EQUIVALENT feet of pipe on both the intake venting arrangement and exhaust venting arrangement must include any 3 inch PVC elbows which equals (5) EQUIVALENT feet of pipe.

Table 2. VENT LENGTH TABLE

Number of 90° Elbows	3" Minimum Pipe (Feet)	3" Maximum Pipe (Feet)	4" Maximum Pipe (Feet)
ONE (1)	7	45	115
TWO (2)	7	40	110
THREE (3)	7	35	105
FOUR (4)	7	30	100
FIVE (5)	7	---	95
SIX (6)	7	---	90

4-inch PVC may be used for a MAXIMUM intake of ONE HUNDRED TWENTY (120) EQUIVALENT FEET and a MAXIMUM exhaust of ONE HUNDRED TWENTY (120) EQUIVALENT FEET. The maximum number of 90° elbows with the 4-inch venting is six (6) on the intake and six (6) on the exhaust. A 90° elbow is equal to five (5) equivalent feet of pipe. One (1) 90° elbow is equal to two (2) 45° elbows. Any venting configuration using less than 50 equivalent feet should use 3-inch venting. See Table 2.

The 3-inch venting terminals (provided) must be used with the 4-inch venting by adding 4x3 reducing couplings at the venting terminals. A reducing coupling is also needed immediately after the condensate elbow (exhaust) and immediately before the 3-inch blower adapter (intake) if direct venting is installed. See Table 2.

IMPORTANT

When multiple units are direct vented through a wall (3-inch or 4-inch venting), all intake vent terminals should be no lower than the highest exhaust vent terminal.

NOTE: This unit can be vented using only PVC (Class 160, ASTM D-2241 Schedule 40, ASTM D-1785 ; or Cellular Core Schedule 40 DWV, ASTM F-891) , Schedule 40 CPVC (ASTM F-411), or ABS (ASTM D-2661) pipe. The fittings, other than the TERMINATIONS should be equivalent to PVC-DWV fittings meeting ASTM D-2665 (Use CPVC fittings, ASTM F-438 for CPVC pipe and ABS fittings, ASTM D-2661/3311 for ABS pipe. If CPVC or ABS pipe and fittings are used, then the proper cement must be used for all joints, including joining the pipe to the Termination (PVC Material). PVC Materials should use ASTM D-2564 Grade Cement; CPVC Materials should use ASTM F-493 Grade Cement and ; ABS Materials should use ASTM D-2235 Grade Cement.

NOTE: for Water Heaters in locations with high ambient temperatures (above 100°F) and/or insufficient dilution air, it is recommended that CPVC or ABS pipe and fittings (**MUST USE SUPPLIED VENT TERMINAL**) be used.

4. It is important that condensate not be allowed to buildup in the exhaust vent pipe. To prevent this from happening the pipe should be installed with a slight, 1/8 inch per five feet (5') of pipe maximum downward slope.

5. The vent system should be supported every five feet (5') of vertical run and every three feet (3') of horizontal run of vent pipe length.

NOTE: Stress levels in the pipe and fittings can be significantly increased by improper installation. If rigid pipe clamps are used to hold the pipe in place, or if the pipe cannot move freely through a wall penetration, the pipe may be directly stressed, or high thermal stresses may be formed when the pipe heats up and expands. Install accordingly to minimize such stresses.

VENT PIPE PREPARATION

1. INITIAL PREPARATION

- A. Make sure the solvent cement you are planning to use is designed for the specific application you are attempting.
- B. Know the physical and chemical characteristics and limitations of the PVC, PVC cellular core, ABS or CPVC piping materials that you are about to use.
- C. Know the reputation of your pipe and cement manufacturer and their products.

D. Know your own qualifications or those of your contractor. The solvent welding technique of joining PVC, PVC cellular core, ABS or CPVC pipe is a specialized skill just as any other pipe fitting technique.

E. Closely supervise the installation and inspect the finished job before start-up.

F. Contact the manufacturer, supplier, or competent consulting agency if you have any questions about the application or installation of PVC, PVC cellular core, ABS or CPVC pipe.

G. Take the time and effort to do a professional job. Shortcuts will only cause you problems and delays in start-up. The majority of failures in these systems are the result of shortcuts and/or improper joining techniques.

2. SELECTION OF MATERIALS

PRIMER

It is recommended that Tetrahydrofuran (THF) be used to prepare the surfaces of pipe and fittings for solvent welding. Do not use water, rags, gasoline or any other substitutes for cleaning PVC cellular core, ABS or CPVC surfaces. A chemical cleaner such as MEK may be used.

CEMENT

The cement should be a bodied cement of approximately 500 to 1600 centipoise viscosity containing 10-20% (by weight) virgin PVC material solvated with tetrahydrofuran (THF). Small quantities of dimethyl formamide (DMF) may be included to act as a retarding agent to extend curing time. Select the proper cement; Schedule 40 cement should be used for Schedule 40 pipe. Never use all-purpose cements, commercial glues and adhesives or ABS cement to join PVC or CPVC pipe and fittings.

SAFETY PRECAUTION: PRIMERS AND CEMENTS ARE EXTREMELY FLAMMABLE AND MUST NOT BE STORED OR USED NEAR HEAT OR OPEN FLAME. ALSO, USE ONLY IN A WELL-VENTILATED AREA.

CONTROLS AND SWITCHES

The BTH-120 and 250 are provided with four pressure switches. Both the BTH 150 and 199 are provided with three pressure switches. These switches are essential to the safe and proper operation of the unit. All switches are wired in series. The controller is set up to shut the unit down whenever there is a failure of any of the switches. It is important to understand the purpose of each switch.

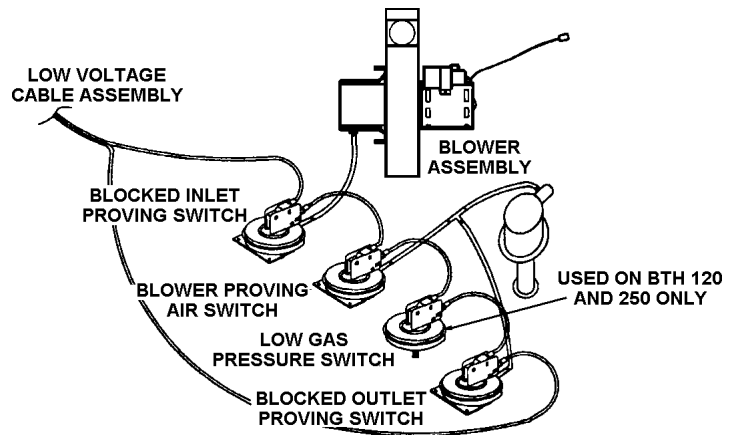

FIGURE 13

BLOWER PROVER SWITCH

(SEE FIGURE 13)

The Blower Prover Switch is provided on the heater to verify that the fan is operating. It is a positive pressure switch whose electrical contacts are normally open. When the fan increases the pressure in the burner, the pressure switch will allow the electrical contacts to close. The pressure switch is connected to the burner tap by a piece of tygon tubing. This

tubing must be connected in order for the switch to change the electrical contacts. The controller requires that the electrical contacts on this air flow switch be open before it will allow the blower to come on.

BLOCKED OUTLET PROVER SWITCH

(SEE FIGURE 13)

The Blocked Outlet Prover Switch is set up to shut the unit off when a build-up of positive pressure in the exhaust vent pipe occurs. This switch is a positive pressure switch that requires an increase in pressure to change the electrical contacts from normally closed to open. When this switch prevents the unit from igniting, most likely the exhaust is blocked by some means. Check to see if the condensate is allowed to flow freely from the exhaust elbow and for obstructions in the exhaust venting and exhaust vent terminal. Also verify that there is no more than fifty equivalent feet of three inch PVC vent pipe on the exhaust.

BLOCKED INLET PROVER SWITCH

(SEE FIGURE 13)

The Blocked Inlet Prover Switch is set up to shut the unit off when a build-up of negative pressure in the intake vent pipe occurs. This switch is a negative pressure switch that requires an increase in negative pressure to change the electrical contacts from normally closed to open. The switch is connected to the pressure tap on the PVC flange connected to the inlet of the blower. When this switch prevents the unit from igniting, most likely the intake is blocked by some means. Check to see if there is no more than fifty equivalent feet of three inch PVC vent pipe on the intake. Also verify that the intake and intake vent terminal is free of obstructions that may prevent air from entering the unit.

LOW GAS PRESSURE SWITCH

(SEE FIGURE 13)

The Low Gas Switch (LGS) is a single-pole, normally open pressure switch that will close its contacts when a rising pressure of 5.0 in. W.C. is encountered. The contacts will open when the pressure falls below the fixed set point of 5.0 in. W.C. The LGS monitors the gas supply pressure to the heater. If the gas supply falls below 5.0 in. W.C., the main burner is extinguished (if heater is running) or the heater will not start up.

ON/OFF SWITCH

The ON/OFF Switch is a single-pole, single-throw rocker switch. This switch provides 120V from the line source to the heater.

CAUTION

THE WATER HEATER IS POLARITY SENSITIVE. BEFORE APPLYING ELECTRICITY TO THIS HEATER BE CERTAIN THAT SUPPLY NEUTRAL WIRE TO GROUND CHECK INDICATES ZERO VOLTAGE.

HOT SURFACE IGNITER

The Hot Surface Igniter is a device that ignites the main burner by high temperature (>1800°F). When 120VAC is applied to the igniter, sufficient heat is generated to ignite the main burner. Although improvements have been made to strengthen the igniter, it is still fragile and care must be taken when handling the igniter to prevent breakage.

GAS PIPING

Contact your local gas service company to ensure that adequate gas service is available and to review applicable installation codes for your area.

Size the main gas line in accordance with Table 3. The figures shown are for straight lengths of pipe at 0.5 in. W.C. pressure drop, which is considered normal for low pressure systems. Note that fittings such as elbows and tees will add to the pipe pressure drop.

CAUTION

DO NOT USE FLEXIBLE GAS PIPING.

TABLE 3
MAXIMUM CAPACITY OF PIPE
IN CUBIC FEET OF GAS PER HOUR
(Based upon a Pressure Drop of 0.5 inch Water Column and 0.6 Specific Gravity Gas and max. gas pressure of 0.5 psig)

Length in Feet	NOMINAL IRON PIPE SIZES, INCHES								
	1/2"	3/4"	1"	1 1/4"	1 1/2"	2"	2 1/2"	3"	4"
10	175	360	680	1,400	2,100	3,950	6,300	11,000	23,000
20	120	250	465	950	1,460	2,750	4,350	7,700	15,800
30	97	200	375	770	1,180	2,200	3,520	6,250	12,800
40	82	170	320	660	990	1,900	3,000	5,300	10,900
50	73	151	285	580	900	1,680	2,650	4,750	9,700
60	66	138	260	530	810	1,520	2,400	4,300	8,800
70	61	125	240	490	750	1,400	2,250	3,900	8,100
80	57	118	220	460	690	1,300	2,050	3,700	7,500
90	53	110	205	430	650	1,220	1,950	3,450	7,200
100	50	103	195	400	620	1,150	1,850	3,250	6,700
125	44	93	175	360	550	1,020	1,650	2,950	6,000
150	40	84	160	325	500	950	1,500	2,650	5,500
175	37	377	145	300	460	850	1,370	2,450	5,000
200	36	72	135	280	430	800	1,280	2,280	4,600

WARNING

THE HEATER IS NOT INTENDED FOR OPERATION AT HIGHER THAN 14.0" WATER COLUMN (1/2 POUND PER SQUARE INCH) SUPPLY GAS PRESSURE. HIGHER GAS SUPPLY PRESSURES REQUIRE SUPPLEMENTAL REDUCING SERVICE REGULATION. EXPOSURE TO HIGHER GAS SUPPLY PRESSURE MAY CAUSE DAMAGE TO THE GAS CONTROLS WHICH COULD RESULT IN FIRE OR EXPLOSION. IF OVERPRESSURE HAS OCCURRED SUCH AS THROUGH IMPROPER TESTING OF GAS LINES OR EMERGENCY MALFUNCTION OF THE SUPPLY SYSTEM THE GAS VALVE MUST BE CHECKED FOR SAFE OPERATION. MAKE SURE THAT THE OUTSIDE VENTS ON THE SUPPLY REGULATORS AND THE SAFETY VENT VALVES ARE PROTECTED AGAINST BLOCKAGE. THESE ARE PARTS OF THE GAS SUPPLY SYSTEM, NOT THE HEATER. VENT BLOCKAGE MAY OCCUR DURING ICE STORMS.

IT IS IMPORTANT TO GUARD AGAINST GAS VALVE FOULING FROM CONTAMINANTS IN THE GAS WAYS. SUCH FOULING MAY CAUSE IMPROPER OPERATION, FIRE OR EXPLOSION.

IF COPPER SUPPLY LINES ARE USED THEY MUST BE INTERNALLY TINNED AND CERTIFIED FOR GAS SERVICE.

BEFORE ATTACHING THE GAS LINE BE SURE THAT ALL GAS PIPE IS CLEAN ON THE INSIDE.

TO TRAP ANY DIRT OR FOREIGN MATERIAL IN THE GAS SUPPLY LINE, A DIRT LEG (SOMETIMES CALLED A SEDIMENT TRAP OR DRIP LEG) MUST BE INCORPORATED IN THE PIPING (SEE FIG. 14). THE DIRT LEG MUST BE READILY ACCESSIBLE AND NOT SUBJECT TO FREEZING CONDITIONS. INSTALL IN ACCORDANCE WITH RECOMMENDATIONS OF SERVING GAS SUPPLIERS. REFER TO THE NATIONAL FUEL GAS CODE.

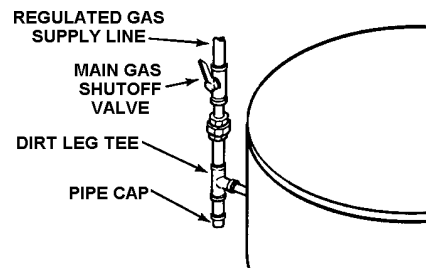

FIGURE 14

CONNECTION OF GAS PIPE

1. When connecting gas pipe to unit, apply wrench to flange only. Note: Do not use wrench on gas valve or gas bracket. See Figure 15.

2. **PERFORM THE GAS LEAK TEST ANY TIME WORK IS DONE ON A GAS SYSTEM TO AVOID THE POSSIBILITY OF FIRE OR EXPLOSION WITH PROPERTY DAMAGE, PERSONAL INJURY OR LOSS OF LIFE.**

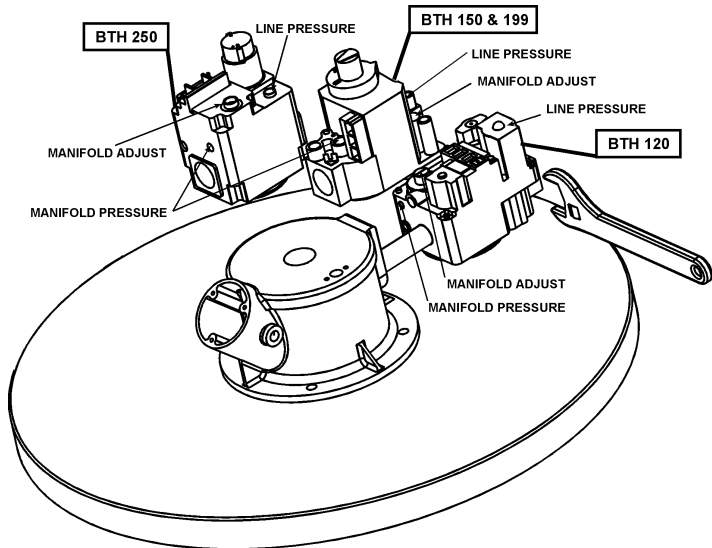

FIGURE 15

The Gas Leak Test is performed as follows: Paint pipe connections upstream of gas control with a rich soap and water solution to test for leaks before operating main burner. Bubbles indicate gas leak. To stop leak, tighten pipe connections. After piping connections are checked, turn on main burner. With main burner in operation, paint pipe joints (including flanges), pilot gas tubing connections and control inlet and outlet with rich soap and water solution. Bubbles indicate gas leak. To stop leak, tighten flange screws, joints and pipe connections. Replace part if leak can't be stopped.

To prevent damage, care must be taken not to apply too much torque when attaching gas supply pipe to gas valve inlet.

Apply joint compounds (pipe dope) sparingly and only to the male threads of pipe joints. Do not apply compound to the first two threads. Use compounds resistant to the action of liquefied petroleum gases.

DISCONNECT THE APPLIANCE AND ITS MANUAL GAS SHUTOFF VALVE FROM THE GAS SUPPLY PIPING SYSTEM DURING ANY SUPPLY PRESSURE TESTING EXCEEDING 1/2 PSIG. GAS SUPPLY LINE MUST BE CAPPED WHEN DISCONNECTED FROM THE HEATER. FOR TEST PRESSURES OF 1/2 PSIG OR LESS, THE APPLIANCE NEED NOT BE DISCONNECTED, BUT MUST BE ISOLATED FROM THE SUPPLY PRESSURE TEST BY CLOSING THE MANUAL GAS SHUTOFF VALVE.

BEFORE PLACING THE HEATER IN OPERATION, CHECK FOR GAS LEAKAGE. USE SOAP AND WATER SOLUTION OR OTHER MATERIAL ACCEPTABLE FOR THE PURPOSE OF LOCATING GAS LEAKS. DO NOT USE MATCHES, CANDLES, FLAME OR OTHER SOURCES OF IGNITION FOR THIS PURPOSE.

PURGING

Gas line purging is required with new piping or systems in which air has entered.



CAUTION

PURGING SHOULD BE PERFORMED BY PERSONS EXPERIENCED IN THIS

TYPE OF GAS SERVICE. TO AVOID RISK OF FIRE OR EXPLOSION, PURGE DISCHARGE MUST NOT ENTER CONFINED AREAS OR SPACES WHERE IGNITION CAN OCCUR. THE AREA MUST BE WELL VENTILATED AND ALL SOURCES OF IGNITION MUST BE INACTIVATED OR REMOVED.

GAS METER SIZE - CITY GASES ONLY

Be sure that the gas meter has sufficient capacity to supply the full rated gas input of the water heater as well as the requirements of all other gas fired equipment supplied by the meter. If the gas meter is too small, ask the gas company to install a larger meter having adequate capacity.

GAS PRESSURE REGULATION

Main line gas pressure to the water heater should be between a maximum 14.0" W.C. and a minimum as shown in Table 4: that is, for Natural Gas, 5.0" W.C. for BTH 120 & 250 or 4.5" W.C. for BTH 150 & 199 or; for L.P. Gas, 11.0" W.C. The inlet gas pressure must not exceed the maximum value. A service regulator should be installed within ten feet (10') of unit.

GAS VALVES



WARNING

SHOULD OVERHEATING OCCUR OR THE GAS SUPPLY FAIL TO SHUT OFF, TURN OFF THE MANUAL GAS CONTROL VALVE TO THE APPLIANCE.

SYSTEM CONNECTIONS

The system installation must conform to these instructions and to the local code authority having jurisdiction. Good practice requires that all heavy piping be supported.

THERMOMETERS (Not Supplied)

Thermometers should be obtained and field installed as shown in the installation diagrams.

Thermometers are installed in the system as a means of detecting the temperature of the outlet water supply.

RELIEF VALVE

This heater is equipped with an approved temperature and pressure relief valve. ASME ratings cover pressure relief. A.G.A. ratings cover release rate with temperature actuation.

FOR SAFE OPERATION OF THE WATER HEATER, THE RELIEF VALVE(S) MUST NOT BE REMOVED OR PLUGGED.

In addition to the appliance relief valve, each remote storage tank which may be used in conjunction with this appliance shall also be installed with a properly sized, rated and approved temperature (ANSI) and pressure (ASME) relief valve(s). This relief valve shall comply with the standard for relief valves and automatic gas shutoff devices for hot water supply systems. ANSI Z21.22

Your local code authority may have other specific relief valve requirements.



WARNING

THE PURPOSE OF A RELIEF VALVE IS TO AVOID EXCESSIVE PRESSURE OR TEMPERATURE INTO THE STEAM RANGE, WHICH MAY CAUSE SCALDING AT FIXTURES, TANK EXPLOSION, SYSTEM OR HEATER DAMAGE. NO VALVE IS TO BE PLACED BETWEEN THE RELIEF VALVE AND THE TANK.

A DRAIN LINE MUST BE CONNECTED TO THE RELIEF VALVE TO DIRECT DISCHARGE TO A SAFE LOCATION TO AVOID SCALDING OR WATER DAMAGE. THIS LINE MUST NOT BE REDUCED FROM THE SIZE OF THE VALVE OUTLET AND MUST NOT CONTAIN VALVES OR RESTRICTIONS, NOR SHOULD IT BE LOCATED IN FREEZING AREAS. DO NOT THREAD OR CAP THE END OF THIS LINE. RESTRICTED OR BLOCKED DISCHARGE WILL DEFEAT THE PURPOSE OF THE VALVE AND IS UNSAFE. THE DISCHARGE LINE SHALL BE INSTALLED TO ALLOW COMPLETE DRAINAGE OF BOTH THE VALVE AND LINE.

WATER LINE CONNECTIONS

This manual provides detailed installation diagrams (see back section of this manual) for typical methods of application for the water heaters.

The water heater may be installed by itself, or with a separate storage tank. When used with a separate storage tank, the circulation may be either by gravity or by means of circulating pump. When a circulating pump is used, it is important to note that the flow rate should be slow so that there will be a minimum of turbulence inside the heater.

CLOSED SYSTEM

CAUTION

A closed system will exist if a check valve (without bypass), pressure reducing valve (without bypass), or a water meter (without bypass) is installed in the cold water line between the water heater and street main (or well).

Excessive pressure may develop causing premature tank failure or intermittent relief valve operation. This type of failure is not covered by the limited warranty. An expansion tank or a similar device may be required in the inlet supply line between the appliance and the meter or valve to compensate for the thermal expansion of water under supply pressure.

If a water heater is installed in a closed water system, check local codes or contact the water supplier or local plumbing inspector on how to control this situation.

HEATER WIRING

IF ANY OF THE ORIGINAL WIRE AS SUPPLIED WITH THE APPLIANCE MUST BE REPLACED, IT MUST BE REPLACED WITH 105°C WIRE OR ITS EQUIVALENT, EXCEPT IN THE BURNER HOUSING. IN THIS CASE USE 200°C WIRE.

THE COMPUTER CONTROL REQUIRES A SOURCE OF STABLE CLEAN ELECTRICITY FOR PROPER OPERATION. INSTALLING THE HEATER ON A BRANCH CIRCUIT THAT HAS ELECTRONIC NOISE, IS SUBJECT TO FLUCTUATIONS IN VOLTAGE LEVEL OR HAS AN APPLIANCE WHICH GENERATES EMF OF RFI INTERFERENCE CAN CAUSE THE CONTROLLER TO MALFUNCTION. A HIGH QUALITY POWER CONDITIONER MUST BE INSTALLED IF THE ABOVE CONDITIONS EXIST. MALFUNCTIONS CAUSED BY A POOR ELECTRICAL SUPPLY ARE NOT COVERED UNDER YOUR WARRANTY.

The controller is wired to the heater as shown in figures 16 & 17. The model and rating plate provides the electrical information needed to size the complete heater branch supply.

All electrical work must be installed in accordance with the National Electrical Code and local requirements.

When installed, the appliance must be electrically grounded in accordance with local codes or, in the absence of local codes, with the National Electrical Code, ANSI/NFPA 70.

DO NOT ENERGIZE THE BRANCH CIRCUIT BEFORE THE HEATER TANK IS FILLED WITH WATER.

NOTE: This controller is Polarity Sensitive. If the Hot and Neutral Supply Voltage is reversed, the controller will not sense flame. Verify polarity before connecting the unit.

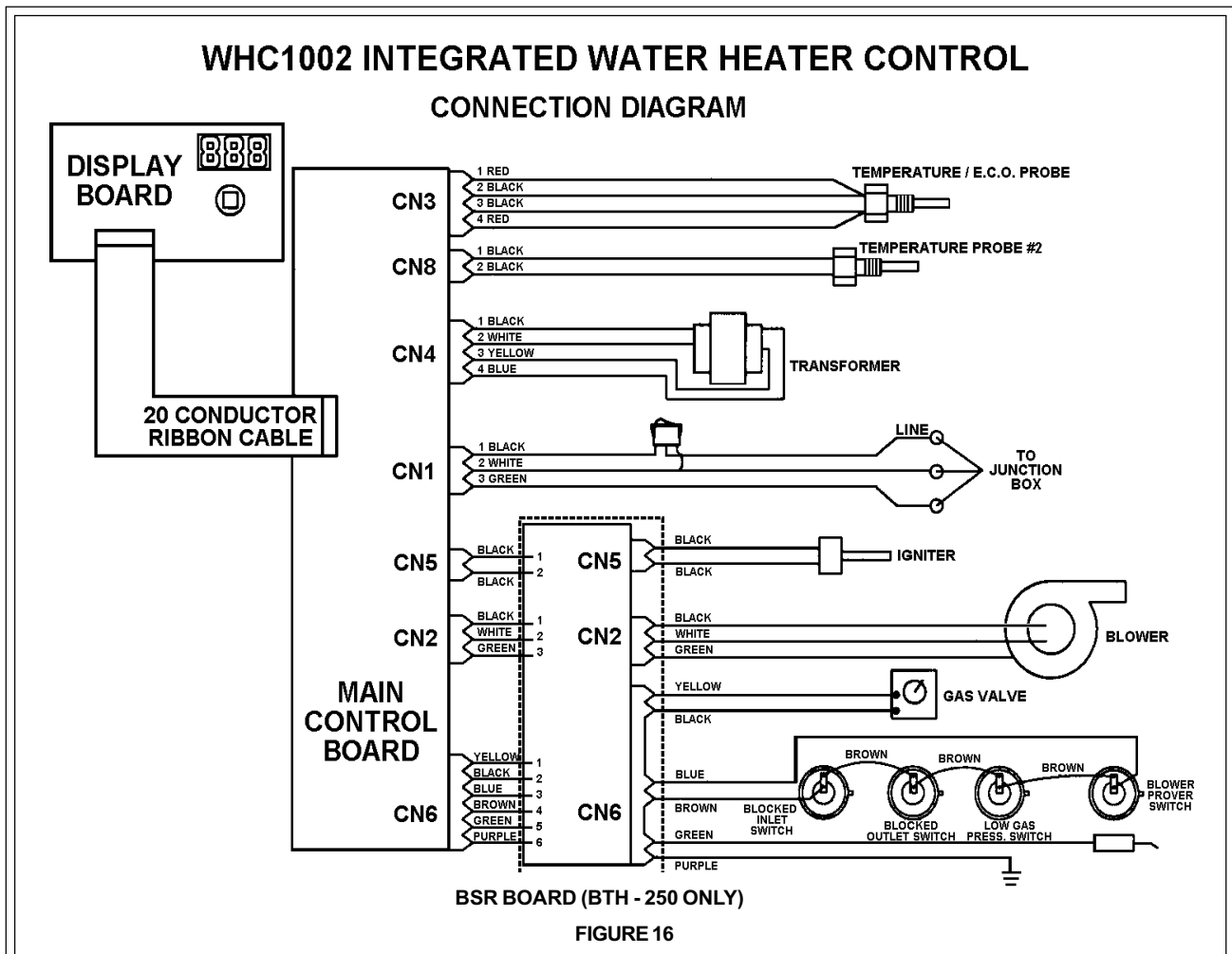

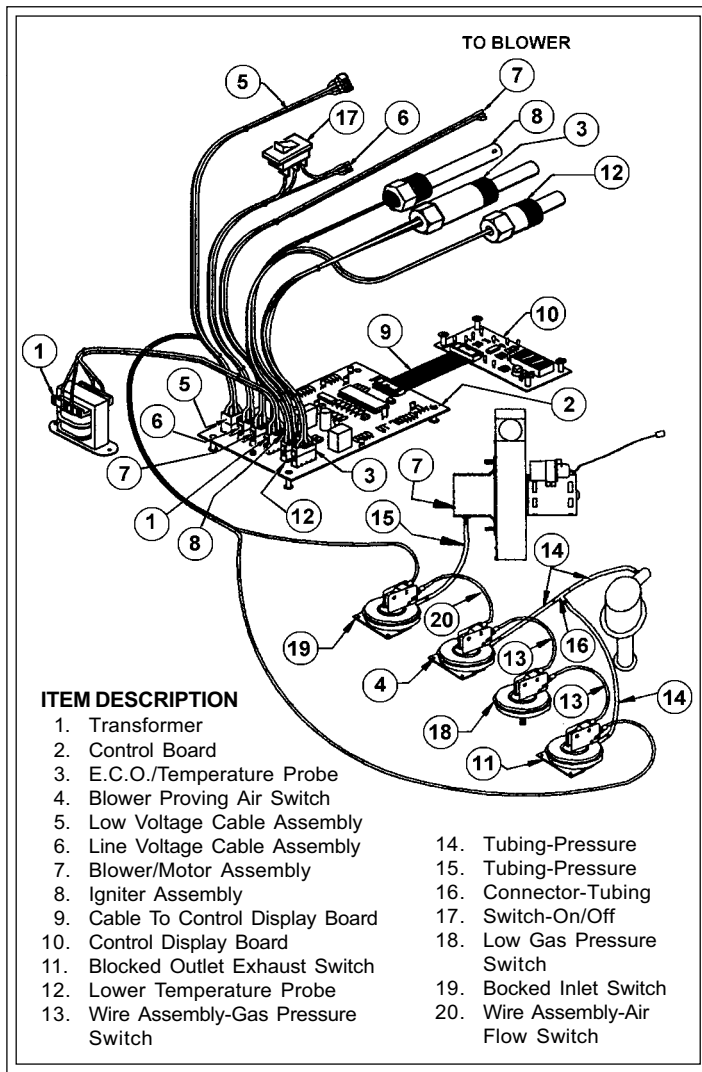

FIGURE 17

OPERATION

SEQUENCE OF OPERATION

Typical Control/Appliance Operating Sequence

- When the control is powered, it should first display "0", then the input line voltage ("120"), the calibration setting (12), then the actual water temperature in the tank.
- If the control determines that the actual water temperature inside the tank is below the programmed temperature setpoint less the differential, a call for heat is activated.
- The control then performs selected system diagnostic checks. This includes confirming the proper state of the air switch and ECO limit device.
- If all checks are successfully passed, the combustion blower is energized for the pre-purge cycle.
- When the pre-purge cycle is complete, power is applied to the igniter element for the igniter warm-up period.
- At the conclusion of the igniter warm-up period, the gas valve will open, allowing gas to enter the burner chamber.
- The igniter will remain on for a short predetermined time period, then will be turned off.

- After an additional 2 seconds, the control will monitor the flame sense probe to confirm a flame is present. If a flame is not verified within this time period, the gas valve will immediately be closed, and the blower will continue to run for approximately 10 seconds. The control will then return to step 2.
- If a flame is confirmed, the control will enter the heating mode where it will continue heating the tank water until the setpoint temperature plus differential is reached. At this point, the gas valve is closed and the control enters the post-purge cycle.
- The combustion blower will run for the duration of the post purge cycle to purge the system of all combustion gases. When the post purge cycle is complete, the blower is de-energized and will coast to a stop.
- The control will now enter the idle state while continuing to monitor the internal tank water temperature and the state of other system devices. If the temperature drops below the setpoint value less differential, the control will automatically return to step 2 and repeat the entire operating cycle. During this idle state, if the control detects an improper operating state for external devices such as the ECO switch, vent switch, pressure switch, etc., the appropriate LED(s) on the Display Board will be illuminated indicating the nature of the fault.

SELF DIAGNOSTIC CONTROLLER

This controller is designed for ignition lockout after three consecutive failed attempts to light. If lockout occurs, the display lights will match Figure 18. Along with this, a numeric message will appear in the display. The following list of ERROR CODES illustrates possible numeric failures.

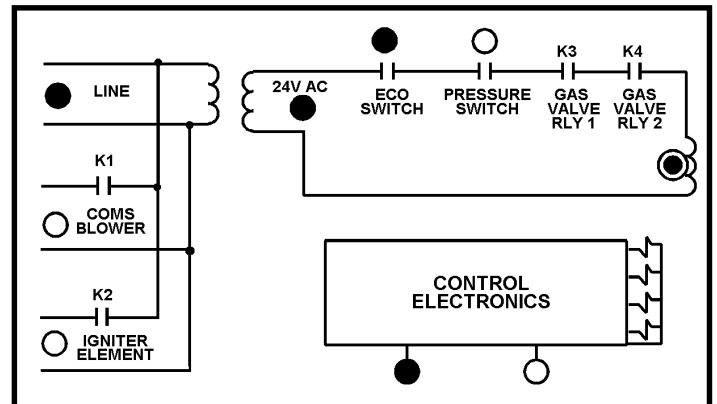

FIGURE 18

GAS VALVE LED FLASHING

This condition results from a failure to establish burner ignition after three successive trials. In such cases:

- Investigate the possible cause and remedy any observations.
- Momentarily depress the button on the display panel to reset the lockout condition.
- Confirm proper appliance operation.

Possible Cause	Remedy
1. Burner ground wire broken or corroded	1. Check wire and connection at burner
2. Connectors unplugged	2. Check connections
3. Igniter broken	3. Replace igniter
4. Flame probe faulty	4. Replace flame probe
5. Gas shut off	5. Turn on gas supply
6. Clogged gas valve	6. Replace gas valve
7. Faulty gas valve	7. Replace gas valve
8. Defective control	8. Replace control
9. Burner improperly adjusted	9. Adjust burner
10. Dirty burner	10. Clean burner

ERROR CODES

The following Error Codes are external to the controller.

- 01 Pressure Switch Fail On, should be Off
- 11 Pressure Switch Fail Off, should be On
- 02 Ignition Fail after 3 attempts
- 04 ECO Open
- 05 Temperature Probe Open
- 15 Temperature Out of Bounds < 30 degrees
- 25 Temperature Out of Bounds > 220 degrees

The following Error Codes are internal to the controller.

- 113 Flame On Should be Off Fail
- 22 Ignition Relay Fail is On, should be Off
- 112 Ignition Relay Fail is Off, should be On
- 101 K2 Fail in K1
- 102 Main Loop Fail in K2
- 103 K1 Fail in Main Loop

Gas Valve Power Supply. (*WDPS Watch Dog Power Supply).

- 106 WDPS Fail to be Off
- 107 WDPS Fail to be On
- 108 WDPS Fail to be On
- 116 Gas Valve Relay Fail is off, should be On
- 117 Gas Valve Relay Fail is On, should be Off

Checks The ROM (Read Only Memory).

- 200 CRC Check Sum Error

Checks The CPU (Central Processing Unit).

- 201 CPU Instruction Test Error
- 202 CPU Instruction Test Error
- 203 CPU Instruction Test Error

Checks the RAM (Random Access Memory).

- 205 RAM Test Fail

SW Check to see what the Last State it was in.
ie., Fails if it can from the wrong place

- 125 State Error
- 126 State Error
- 128 State Error
- 127 State Error
- 129 State Error
- 131 State Error
- 132 State Error

These State Numbers are not used.

- 230 Executed State 3 (Not Implimented) h.s.
- 240 Executed State 4 (Not Implimented) h.s
- 210 Executed State 10 (Not Implimented) h.s.
- 213 Executed State 13 (Not Implimented) h.s.
- 214 Executed State 14 (Not Implimented) h.s.
- 216 Executed State 16 (Not Implimented) h.s.

FAULT CONDITIONS

The controller is set up to provide additional status indicators under Fault Conditions. The following figures are possible Fault Conditions.

NO INCOMING LINE VOLTAGE (Figure 19)

Line LED Off

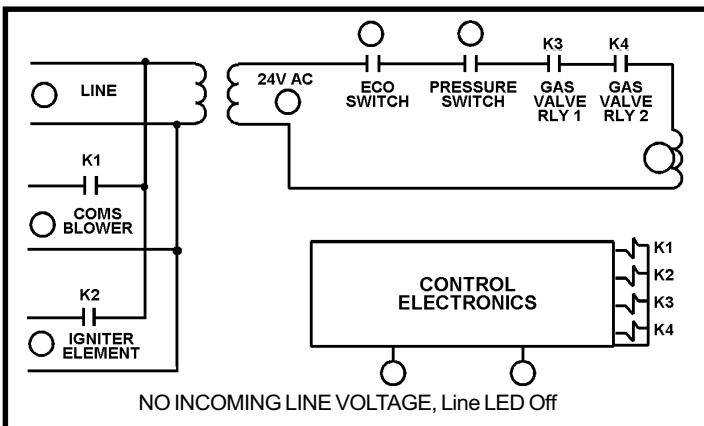

FIGURE 19

Possible Cause	Remedy
1. No Input Power	1. Apply Power
2. Wiring Disconnected	2. Check all wiring
3. One or more wiring receptacles disconnected from control	3. Reconnect plugs on control, confirm all are fully seated
4. LED burned out	4. Ignore or replace control

NO LOW VOLTAGE (Figure 20) 24V AC LED Off

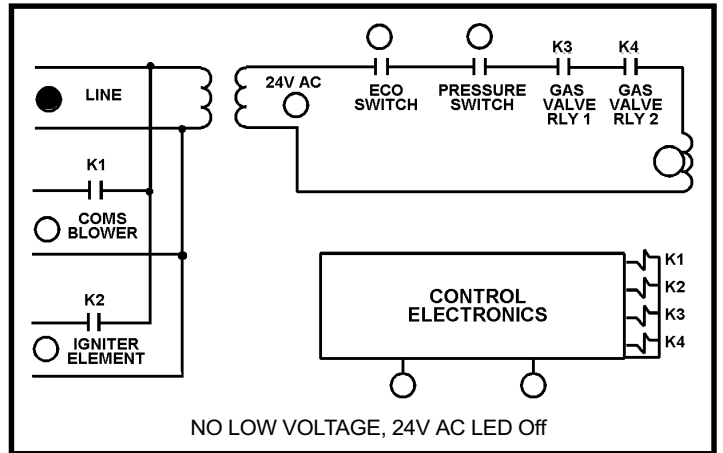

FIGURE 20

NOTE: The transformer is of Class II variety and has an internal non-replaceable fuse. If blown, a problem may exist with the control which is affecting the transformer. In such cases, the control should be replaced as well.

Possible Cause	Remedy
1. Transformer wiring problem	1. Repair Wiring
2. Defective Transformer	2. Replace Transformer
3. LED burned out	3. Ignore or replace control

TEMPERATURE PROBE FAULT (Figure 21)

Water Temp LED Flashing

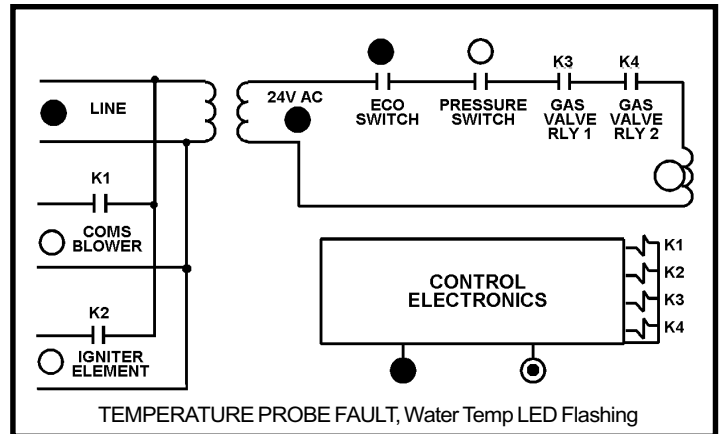

FIGURE 21

This condition accommodates multiple failure modes. To more accurately determine the cause of failure, press the pushbutton on the display board.

Display Flashes "05" when button is pressed:

Possible Cause	Remedy
1. Temperature Probe wiring open	1. Repair Wiring
2. Defective probe	2. Replace probe

Display Flashes "15" when button is pressed:

Possible Cause	Remedy
1. No water in tank and tank in freezing conditions	1. The symptom does not reflect a control problem
2. Water in tank above freezing	2. Temperature probe out of tolerance, replace temp. probe

Display Flashes "25" when button is pressed:

Possible Cause	Remedy
1. Water in tank is low, probe immersed in steam	1. Fill tank
2. Probe wiring shorted	2. Repair wiring
3. Defective probe	3. Replace probe

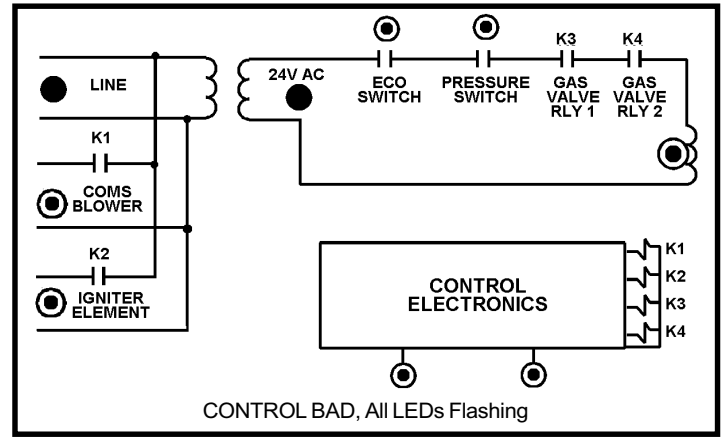

FIGURE 23

Possible Cause	Remedy
1. Temp. Probe unplugged	1. Check connectors
2. Temp. probe wiring damaged	2. Repair wiring
3. Water in tank too hot	3. Normal condition when water temperature exceeds safety limit. Allow water to cool or admit water into tank and manually reset the control. Determine cause for overtemp condition.

COMBUSTION AIR BLOCKAGE (Figure 24)

Pressure Switch LED Flashing:

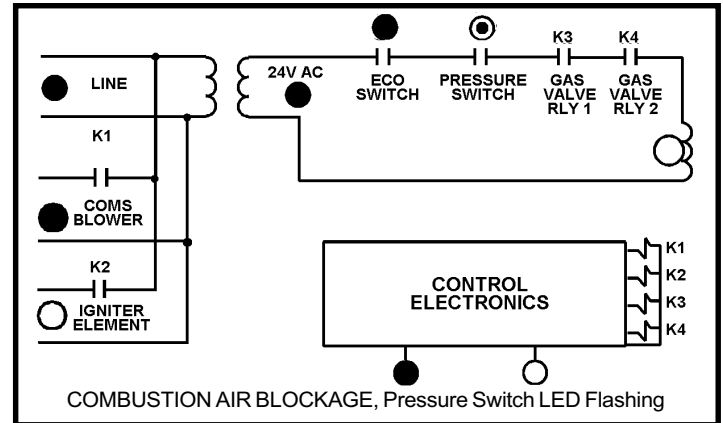

FIGURE 24

ECO SWITCH OPEN (Figure 22)

ECO LED Flashing:

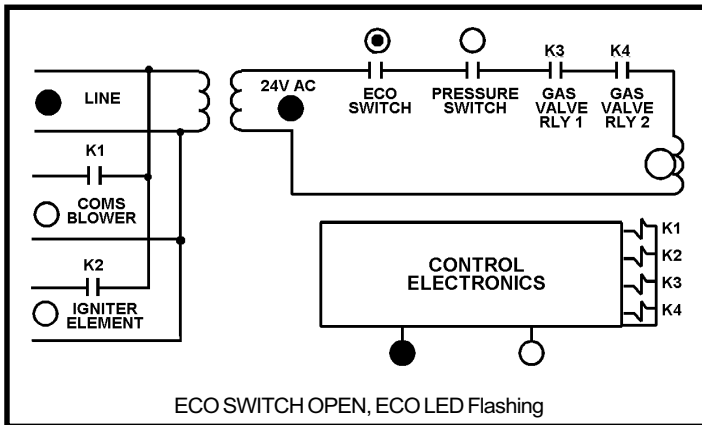

FIGURE 22

Possible Cause	Remedy
1. This indicates the control has failed on of its internal diagnostic self-tests.	1. Press button on the display board to reset control. If this error occurs repeatedly, replace control.

CONTROL BAD (Figure 23)

All LEDs Flashing:

Possible Cause	Remedy
1. Combustion air blocked	1. Check exhaust piping and flue for obstructions
2. Blower not operating: a. Check blower wiring b. Check blower motor	2. a. Repair wiring b. Replace blower motor
3. Defective air switch	3. Replace air switch
4. Pressure switch jumped out	4. This controller must sense an open contact on the blower proving airflow switch before the blower comes on. Check to see if blower proving airflow switch is still connected to the unit.

PRIOR TO START UP REQUIRED ABILITY

INSTALLATION OR SERVICE OF THIS WATER HEATER REQUIRES ABILITY EQUIVALENT TO THAT OF A LICENSED TRADESMAN IN THE FIELD INVOLVED. PLUMBING, AIR SUPPLY, VENTING, GAS SUPPLY AND ELECTRICAL WORK ARE REQUIRED.

Before attempting start-up, thoroughly study and familiarize yourself with the exact sequence of operation and all other details on the specific heater being used.

The power burner is equipped with an ignition system which automatically sequences prepurge and ignition, senses and ignites main burner flame and sequences burner operation. Heater is equipped with an ignition control which locks out after three unsuccessful ignition attempts. Familiarize yourself with the sequence of operation of this unit prior to start-up.

Be certain that the water heater is full of water, that air is purged from all lines, there are no leaks (gas and water), and all inlet water lines are open.

The following test equipment should be on hand (all test equipment must be acclimated to ambient temperature before calibration and use.)

- Two U-tube manometers or calibration 0-10" and 0-35" W.C. pressure gauges.
- Attach a gas pressure gauge or manometer to the upstream side of main gas cock and a gas pressure gauge or manometer to the manifold pressure tap (see Figure 15).
- You are now ready to begin the burner start-up procedure.

OPERATING INSTRUCTIONS

IMPORTANT

IT IS RECOMMENDED THAT A QUALIFIED SERVICE TECHNICIAN PERFORM THE INITIAL FIRING OF THE HEATER. AT THIS TIME THE USER SHOULD ASK THE TECHNICIAN ANY QUESTIONS IN REGARD TO THE OPERATION AND MAINTENANCE OF THE UNIT.

CAUTION

BEFORE PROCEEDING WITH THE OPERATION OF THE UNIT, MAKE SURE HEATER AND SYSTEM ARE FILLED WITH WATER AND ALL AIR IS EXPELLED FROM HEATER AND PIPING.

NEVER OPERATE THE HEATER WITHOUT FIRST BEING CERTAIN IT IS FILLED WITH WATER AND A TEMPERATURE AND A PRESSURE RELIEF VALVE IS INSTALLED IN THE RELIEF VALVE OPENING OF THE HEATER. DO NOT ATTEMPT TO OPERATE HEATER WITH COLD WATER INLET VALVE CLOSED.

FILLING:

1. Close the heater drain valve.
2. Open a nearby hot water faucet to permit the air in the system to escape.
3. Fully open the cold water inlet pipe valve allowing the heater and piping to be filled.
4. Close the hot water faucet as water starts to flow.
5. The heater is ready to be operated.

THE MAIN MANUAL GAS SHUTOFF VALVE MUST HAVE BEEN CLOSED FOR AT LEAST FIVE (5) MINUTES. THIS WAITING PERIOD IS AN IMPORTANT SAFETY STEP. ITS PURPOSE IS TO PERMIT GAS THAT MIGHT HAVE ACCUMULATED IN THE COMBUSTION CHAMBER TO CLEAR. IF YOU DETECT GAS AT THE END OF THIS PERIOD, DO NOT PROCEED WITH LIGHTING. RECOGNIZE THAT GAS ODOR, EVEN IF IT SEEMS WEAK, MAY INDICATE THE PRESENCE OF ACCUMULATED GAS SOMEPLACE IN THE AREA WITH A RISK OF FIRE OR EXPLOSION. SEE THE FRONT PAGE FOR STEPS TO BE TAKEN.

DO NOT USE THIS HEATER IF ANY PART HAS BEEN UNDER WATER. IMMEDIATELY CALL A QUALIFIED SERVICE TECHNICIAN TO INSPECT THE HEATER AND TO REPLACE ANY PART OF THE CONTROL SYSTEM AND ANY GAS CONTROL WHICH HAS BEEN UNDER WATER.

LIGHT THE UNIT IN ACCORDANCE WITH THE OPERATING INSTRUCTIONS LABEL ATTACHED TO THE HEATER.



THESE INSTRUCTIONS ARE REPEATED IN THE LIGHTING AND OPERATING LABEL ILLUSTRATION ON PAGE 20 IN THIS MANUAL.

ADJUSTMENT PROCEDURE INITIAL START-UP

A minimum gas supply pressure of 5.0" W.C. (4.5" on BTH 150 and 199) for natural gas (11.0" W.C. for L.P. Gas) is required before making any adjustment to the gas control pressure regulator. Attempts to adjust the regulator during periods of low gas supply pressure could result in overfiring of the heater when the gas supply pressure returns to normal.

1. Check gas line pressure with a manometer.
2. Check manifold pressure (see Table 4, page 20) using a pressure gauge (manometer) connected to the manifold pressure tap on the gas control valve, (Figure 15).

If full rate adjustment is required, remove cover screw from top of the gas control valve, (Figure 15).

Using a small screwdriver, turn adjusting screw clockwise  to increase or counterclockwise  to decrease gas pressure to obtain 4.0" on BTH 120 and 250 (3.5" on BTH 150 and 199) for natural gas (10.0" W.C. for L.P. Gas) Water Column.

3. Cycle the burner on and off several times to check its operation.
4. Check the operation of the limit and operating controls.
5. Check the vent system seams and joints and ensure that there is no discharge of flue products into the room.
6. Check the input rate:

For appliance installation locations with elevations above 2000 feet, refer to HIGH ALTITUDE INSTALLATIONS section of this manual.

- a. Attach a pressure gauge (manometer) to the manifold pressure tap (Figure 16) and refer to Table 4, page 20 for correct pressure.
- b. Use this formula to "clock" the meter. Be sure other gas consuming appliances are not operating during this interval.

$$\frac{3600}{T} \times H = \text{Btuh}$$

Should it be necessary to adjust the gas pressure to the burner, to obtain the full input rate, the steps below should be followed:

- T = Time in seconds to burn 1 cubic foot of gas. (With a stopwatch read the gas meter and measure the amount of time required for the heater to consume 1 cubic foot of gas.)
H = Heating value of gas (in Btu's per cubic foot of gas).
Btuh = Actual heater input rate, in Btuh.

EXAMPLE: (Using BTH-199,900 heater)

$$\begin{aligned} T &= 18.9 \text{ seconds} \\ H &= 1050 \text{ Btu/ft.}^3 \\ \text{BTUH} &= ? \end{aligned} \quad \frac{3600}{18.9} \times 1050 = 199,900 \text{ Btuh}$$

For high altitude installations, compare result to the derated input required for the elevation at the installation location.

- c. Remove the pressure regulator cover screw (Figure 16) and adjust the pressure by turning the adjusting screw with a small screwdriver. Do not exceed 4.0" on BTH 120 and 250 (3.5" on BTH 150 and 199) Water Column.

 Clockwise to increase gas pressure and input rate.

 Counterclockwise to decrease gas pressure and input rate.

- d. "Clock" the meter as in step (b) above.
- e. Repeat steps (c) and (d) until the specified input rate is achieved.
- f. Turn the manual gas valve to "OFF". Replace the pressure regulator cover screw. Remove the pressure gauge or manometer from the manifold pressure tap. Replace the set screw in the manifold pressure tap. If the gas pressure regulator cannot be adjusted to give the full input rating with sufficient gas pressure at the valve, check to ensure the unit is equipped with the correct orifice.

FOR YOUR SAFETY READ BEFORE OPERATING





WARNING: If you do not follow these instructions exactly, a fire or explosion may result causing property damage, personal injury or loss of life.



BEFORE OPERATING: ENTIRE SYSTEM MUST BE FILLED WITH WATER AND AIR PURGED FROM ALL LINES

- A. This appliance does not have a pilot. It is equipped with an ignition device which automatically lights the burner. Do not try to light the burner by hand.
- B. **BEFORE OPERATING** smell all around the appliance area for gas. Be sure to smell next to the floor because some gas is heavier than air and will settle on the floor.
- WHAT TO DO IF YOU SMELL GAS:**
- Do not try to light any appliance.
 - Do not touch any electric switch; do not use any phone in your building.
 - Immediately call your gas supplier from a neighbor's phone. Follow the gas suppliers instructions.
- If you cannot reach your gas supplier, call the fire department.
- C. Use only your hand to push in or turn the gas control knob. Never use tools. If the knob will not push in or turn by hand, don't try to repair it, call a qualified service technician. Force or attempted repair may result in a fire or explosion.
- D. Do not use this appliance if any part has been under water. Immediately call a qualified service technician to inspect the appliance and to replace any part of the control system and any gas control which has been under water.

OPERATING INSTRUCTIONS

1.  STOP! Read the safety information above on this label.
2. Set the thermostat to lowest setting.
3. Turn off all electric power to the appliance.
4. This appliance is equipped with an ignition device which automatically lights the burner. Do not try to light the burner by hand.
5. Remove top cover.
6. Push in control knob slightly and turn clockwise  to "OFF".
7. Wait five (5) minutes to clear out any gas. If you then smell gas,  STOP! Follow "B" in the safety information above on this label. If you don't smell gas, go on to next step.

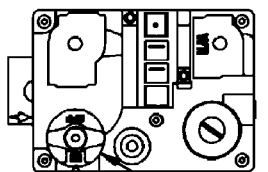

GAS CONTROL KNOB

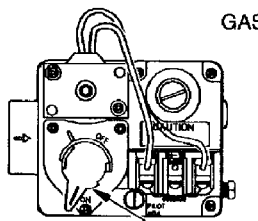

GAS CONTROL KNOB

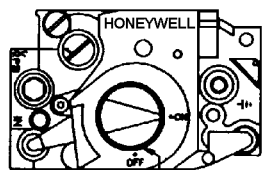

GAS CONTROL KNOB

8. Turn gas control knob counterclockwise  to "ON".
9. Replace top cover.
10. Turn on all electric power to the appliance.
11. Set thermostat to desired setting.
12. If the appliance will not operate, follow the instructions "To Turn Off Gas To Appliance" and call your service technician or gas supplier.

TO TURN OFF GAS TO APPLIANCE

1. Set the thermostat to lowest setting.
2. Turn off all electric power to the appliance if service is to be performed.
3. Remove top cover.
4. Push in gas control knob slightly and turn clockwise  to "OFF". **Do not force.**
5. Replace top cover.

HIGH ALTITUDE INSTALLATIONS



WARNING

UNDER NO CIRCUMSTANCES SHOULD THE INPUT EXCEED THE RATE SHOWN ON THE HEATER RATING PLATE. OVERFIRING COULD RESULT IN DAMAGE OR SOOTING OF THE HEATER.

CATHODIC PROTECTION



CAUTION

HYDROGEN GAS CAN BE PRODUCED IN A HOT WATER SYSTEM SERVED BY THIS HEATER THAT HAS NOT BEEN USED FOR A LONG PERIOD OF TIME (GENERALLY TWO WEEKS OR MORE). HYDROGEN GAS IS EXTREMELY FLAMMABLE. To reduce the risk of injury under these conditions, it is recommended that a hot water faucet be opened for several minutes before using any electrical appliance connected to the hot water system. If hydrogen is present, there will probably be an unusual sound such as air escaping through the pipe as the water begins to flow. There should be no smoking or open flame near the faucet at the time it is open.

PRECAUTIONS

IF THE UNIT IS EXPOSED TO THE FOLLOWING, DO NOT OPERATE HEATER UNTIL ALL CORRECTIVE STEPS HAVE BEEN MADE BY A QUALIFIED SERVICEMAN.

1. FLOODING TO OR ABOVE THE LEVEL OF THE BURNER OR CONTROLS
2. EXTERNAL FIRING
3. DAMAGE
4. FIRING WITHOUT WATER
5. SOOTING

NEVER OPERATE THE HEATER WITHOUT FIRST BEING CERTAIN IT IS FILLED WITH WATER AND A TEMPERATURE AND PRESSURE RELIEF VALVE IS INSTALLED IN THE RELIEF VALVE OPENING OF THE HEATER.

SHOULD OVERHEATING OCCUR OR THE GAS SUPPLY FAIL TO SHUT OFF, TURN OFF THE MANUAL GAS CONTROL VALVE TO THE APPLIANCE.

GENERAL INFORMATION

POWER BURNER

The initial start-up procedure of the unit is provided on page 18.

The sequence of operation of the unit is provided on page 15.

It is important to note that the controller has a reset button on the control box, Figure 1. The reset button is a safety device and would not normally be used.

HIGH LIMIT

The high limit (not adjustable) is factory set to cutout at 202°F. The controller must be manually reset by depressing the reset button on front of the control when water temperature drops to below 160°F.

TABLE 4 GAS SUPPLY SPECIFICATIONS	BTH 120	BTH 150	BTH 120
	& 250	& 199	150 & 199
	Natural Gas	Natural Gas	L.P. Gas
Max. Gas Supply Press. W.C.	14.0	14.0	14.0
Nominal Gas Supply Press. W.C.	7.0	7.0	11.0
Minimal Gas Supply Press. W.C.	5.0	4.5	11.0
Manifold Press. W.C.	4.0	3.5	10.0



WARNING

BTH HEATERS ARE CERTIFIED FOR USE WITHOUT MODIFICATION FOR ALTITUDES UP TO 6500 FEET. INSTALLATIONS ABOVE 6500 FEET MAY REQUIRE REPLACEMENT OF THE BURNER ORIFICE. CALL THE TECHNICAL CENTER @ (800) 627-1953 FOR REQUIREMENTS.

Some gas utility companies derate their gas for altitude, making it unnecessary to install high altitude orifices. Call the local gas or utility company to verify BTU content.

Due to the input rating reduction at high altitudes, the output rating of the appliance is also reduced and should be compensated for in the sizing of the equipment for applications.

MAINTENANCE

GENERAL

KEEP APPLIANCE AREA CLEAR AND FREE FROM COMBUSTIBLE MATERIALS, GASOLINE AND OTHER FLAMMABLE VAPORS AND LIQUIDS. (SEE WARNING ON PAGE 5, LOCATING THE HEATER).

Water heater maintenance includes periodic tank flushing and cleaning, and removal of lime scale. The unit should be inspected and adjusted to maintain proper combustion. Refer to the following table. A periodic inspection of the venting system should be made. Where used, the water circulating pump should be oiled.

MAINTENANCE SCHEDULE

Following are the instructions for performing some of the recommended maintenance. Unit inspection and adjustment should be performed by a competent technician.

COMPONENT	OPERATION	INTERVAL	REQUIRED
Tank	Sediment Removal	Monthly	Flushing
Tank	Lime Scale Removal	Semi Annually	UN-LIME® Delimer
Anode Rods	Inspect	Semi Annually	Replace as Required
Relief Valve	Inspect	Semi Annually	
Circulating Pump (1)	Oiling	Four Months	SAE No. 20 non-detergent motor oil
Blower	Clean Inlet Screen and Blower Wheel	As Required	Soft Brush
Vent System	Inspect	Every 3 Months	Joints should be sealed

(1) If furnished with oiling provision.

FLUSHING

1. Turn off the heater electrical disconnect switch.
2. Open the drain valve and allow water to flow until it runs clean.
3. Close the drain valve when finished flushing.
4. Turn on the heater electrical disconnect switch.

DRAINING

The heater must be drained if it is to be shut down and exposed to freezing temperatures. Maintenance and service procedures may also require draining the heater.

1. Turn off the heater electrical disconnect switch.
 2. Close the cold water inlet valve to heater.
 3. Open a nearby hot water faucet to vent the system.
 4. Open the heater drain valve.
 5. If the heater is being drained for an extended shutdown, it is suggested the drain valve be left open during this period.
- Follow FILLING instructions when restoring hot water service.

SEDIMENT REMOVAL

Waterborne impurities consist of the particles of soil and sand which settle out and form a layer of sediment on the bottom of the tank.

For convenience, sediment removal and lime scale removal should be performed at the same time.

LIME SCALE REMOVAL

The amount of calcium carbonate (lime) released from water is in direct proportion to water temperature and usage. The higher the water temperature or water usage, the more lime deposits are dropped out of the water. This is the lime scale which forms in pipes, heaters and on cooking utensils.

Lime accumulation not only reduces the life of the equipment but also reduces efficiency of the heater and increases fuel consumption.

The usage of water softening equipment greatly reduces the hardness of the water. However, this equipment does not always remove all of the hardness (lime). For this reason it is recommended that a regular schedule for deliming be maintained.

The depth of lime buildup should be measured periodically. Heaters will have about 3" of lime buildup when the level of lime has reached the bottom of the cleanout opening or about 1" of lime buildup if it has reached the drain valve opening. A schedule for deliming should be set up, based on the amount of time it would take for a 1" buildup of lime.

Example 1:

Initial inspection shows 1/2" of lime accumulation. Therefore, the heater can be delimed once a year.

Example 2 :

Initial inspection shows 2" of lime accumulation. Therefore, the heater should be delimed every 3 months.

Sediment and lime scale removal may be accomplished through the cleanout opening furnished on the heater, see Figure 25. The heater must be drained, see DRAINING, before removing cleanout cover on tank.

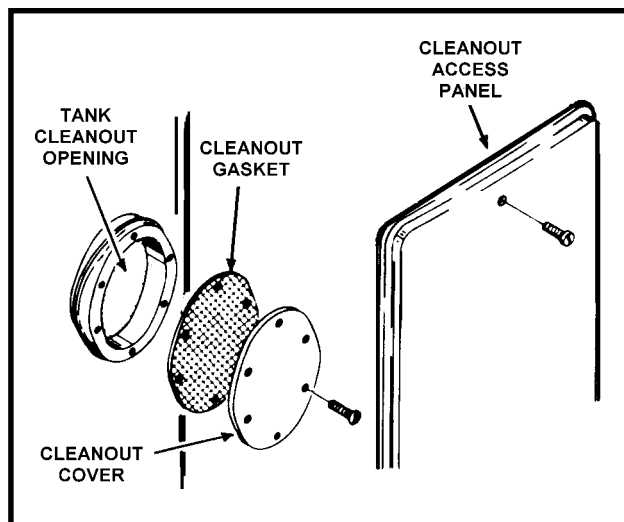

FIGURE 25

To dissolve and remove the more stubborn mineral deposits, A.O. Smith UN•LIME® Professional Delimer should be used.

A.O. Smith UN•LIME® Professional Delimer is an easy to handle patented food grade acid formulated specifically for lime scale removal from all types of water using equipment. Available in 1 gallon (part no. 4763) and 5 gallon (part no. 4813) sizes. Hydrochloric base acids are not recommended for use on glass-lined tanks.

A.O. Smith Form No. 4800, entitled "Why, When and How", describes tank cleaning methods and materials. UN•LIME and the booklet may be obtained through your A.O. Smith dealer or distributor.

The cleanout opening is shown in Figure 25. To clean heater through cleanout opening, proceed as follow:

1. Turn off water inlet valve, the heater electrical disconnect switch and open drain valve.
2. Remove outer cover plate from lower side of heater jacket.
3. Remove cover from cleanout opening.
4. Remove lime, scale or sediment using care not to damage the glass-lining.
5. Inspect cleanout plate gasket: If new gasket is required, replace with A. O. Smith part no. 99038.
6. Install cleanout plate. Be sure to draw plate up tight by tightening screws securely.
7. Close drain valve, open water inlet line and turn on the power burner electrical disconnect switch.
8. Check for water leakage.
9. Replace outer jacket cover plate.

ANODE INSPECTION AND REPLACEMENT

This water heater is equipped with multiple sacrificial anodes. Anodes protect the glass-lined tank from corrosion by sacrificing themselves through electrolysis. When the anode material is consumed, there is no more protection and corrosion of the tank accelerates

Inspection of the anode every 6 to 12 months allows you to identify a spent anode and replace it. Replace the anode when its diameter is 3/8" of an inch, or annually whichever ever is first. Aggressive, very hot and softened water causes rapid consumption of the anode requiring frequent inspections. Anodes are available from your distributor or A.O. Smith.

To inspect or replace an anode:

The anodes on this heater are easily accessible from the top of the heater making replacement simple and quick.

1. Turn the heater off per the lighting instructions. Connect a hose to the drain valve . Locate the hose's discharge in an area where hot water will not cause any damage or injury.
2. Open the drain valve to flush any sediment out of the bottom of the heater.
3. Shut off the cold water supply. Make sure all hot water fixtures and circulating pumps are turned off.
4. Wait for water flow from the hose to stop. Remove the anode using a socket of the appropriate size Sometimes a pry bar will be required to loosen the anode plug . Do not use an impact wrench.
5. Inspect and replace the anode as required. Use a pipe tape or sealant when reinstalling the anode.
6. Close the drain valve . Open a hot water fixture to allow air to escape. Open the cold water supply to heater and allow the tank to fill. Follow the lighting instructions.
7. Check your anode and drain valve for leaks.

DRAIN VALVE AND ACCESS PANELS

The heaters are equipped with a 3/4" drain valve.

An access panel covers the cleanout opening in the tank which is sealed by a gasket and cover, figure 25.

RELIEF VALVE

At least twice a year, the temperature and pressure relief valve should be checked to ensure that it is in operating condition. To check the relief valve, lift the lever at the end of the valve several times. The valve should seat properly and operate freely.

If water does not flow, remove and inspect for obstructions or corrosion. Replace with a new valve of the recommended size as necessary. Inspection of the valve should be performed at least every three years. Do not attempt to repair the valve, as this could result in improper operation and a tank explosion. In areas with poor water conditions, it may be necessary to inspect the T&P valve more often than every three years.

CAUTION

BEFORE MANUALLY OPERATING THE VALVE, MAKE SURE THAT A DRAIN LINE HAS BEEN ATTACHED TO THE VALVE TO DIRECT THE DISCHARGE TO AN OPEN DRAIN. FAILURE TO TAKE THIS PRECAUTION COULD MEAN CONTACT WITH EXTREMELY HOT WATER PASSING OUT THE VALVE DURING THIS CHECKING OPERATION.

If the temperature and pressure relief valve on the heater discharges periodically or continuously, it may be due to thermal expansion of water in a closed water supply system, or, it may be due to a faulty relief valve.

Thermal expansion is the normal response of water when it is heated. In a closed system, thermal expansion will cause the system pressure to build until the relief valve actuation pressure is equaled. Then, the relief valve will open, allowing some water to escape, slightly lowering the pressure.

Contact your water supplier or local plumbing inspector on how to control this situation.

Two common corrections are listed in the Checklist and Service Information which appears later in this manual.

ABOVE ALL, DO NOT PLUG THE TEMPERATURE AND PRESSURE RELIEF VALVE. THIS IS NOT A SOLUTION AND CAN CREATE A HAZARDOUS SITUATION.

CIRCULATING PUMP

The water heating system may include a circulating pump. Where used, it should be lubricated as directed by the circulator manufacturer.

VENT SYSTEM

Examine the vent system every 3 months. Points of inspection are as follows:

1. Check for obstructions and/or deterioration of vent piping and vent hood. Replace immediately where needed.
2. Vent pipe and vent hood screen should be cleaned of foreign material and soot. The screen is located inside the vent hood outlet and is accessible from the outside of the hood. Do not reach inside the vent hood when the heater is in operation.
3. Check all vent system connections for leakage and reseal as required using Hi Temp Silicone sealer or equivalent.

INSTALLATION DIAGRAMS

ONE TEMPERATURE - ONE HEATER VERTICAL STORAGE TANK FORCED CIRCULATION WITH OR WITHOUT BUILDING RECIRCULATION

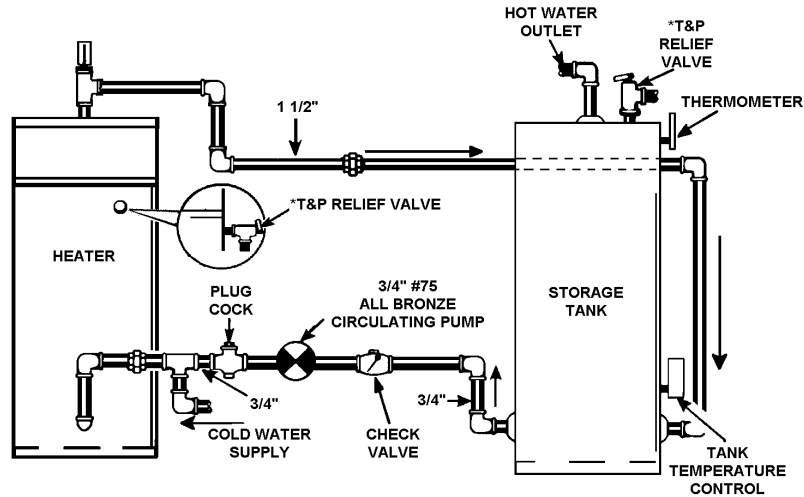
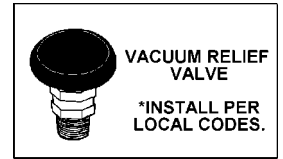
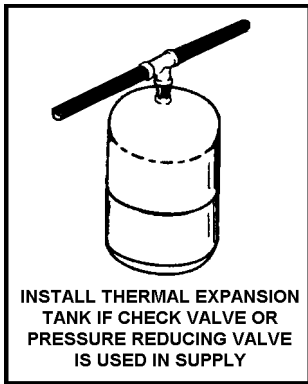

CAUTION: IF BUILDING COLD WATER SUPPLY HAS A BACK-FLOW PREVENTER, CHECK VALVE OR WATER METER WITH CHECK VALVE PROVISIONS FOR THERMAL EXPANSION OF WATER IN THE HOT WATER SYSTEM MUST BE PROVIDED

NOTE: CONNECT RETURN LINE FROM HOT WATER CIRCULATING LOOP (IF USED) TO COLD WATER INLET LINE.

* PIPE TO OPEN DRAIN

INSTALL IN ACCORDANCE WITH LOCAL CODES

ONE TEMPERATURE - ONE HEATER HORIZONTAL STORAGE TANK FORCED CIRCULATION WITH OR WITHOUT BUILDING RECIRCULATION



TEMPERATURE SETTING SHOULD NOT EXCEED SAFE TEMPERATURE AT FIXTURES. SEE WATER TEMPERATURE CONTROL WARNING ON PAGE 4. IF HIGHER PREHEAT TEMPERATURES ARE NECESSARY TO OBTAIN ADEQUATE BOOSTER OUTPUT, ADD AN ANTI-SCALD VALVE FOR HOT WATER SUPPLIED TO FIXTURES.

*PIPE TO OPEN DRAIN

INSTALL IN ACCORDANCE WITH LOCAL CODES

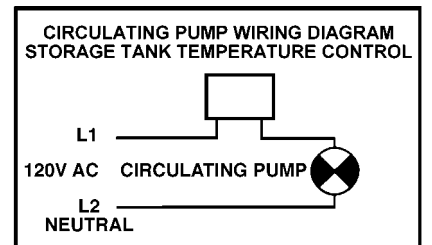
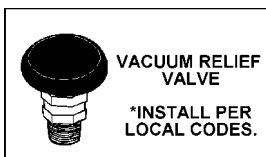
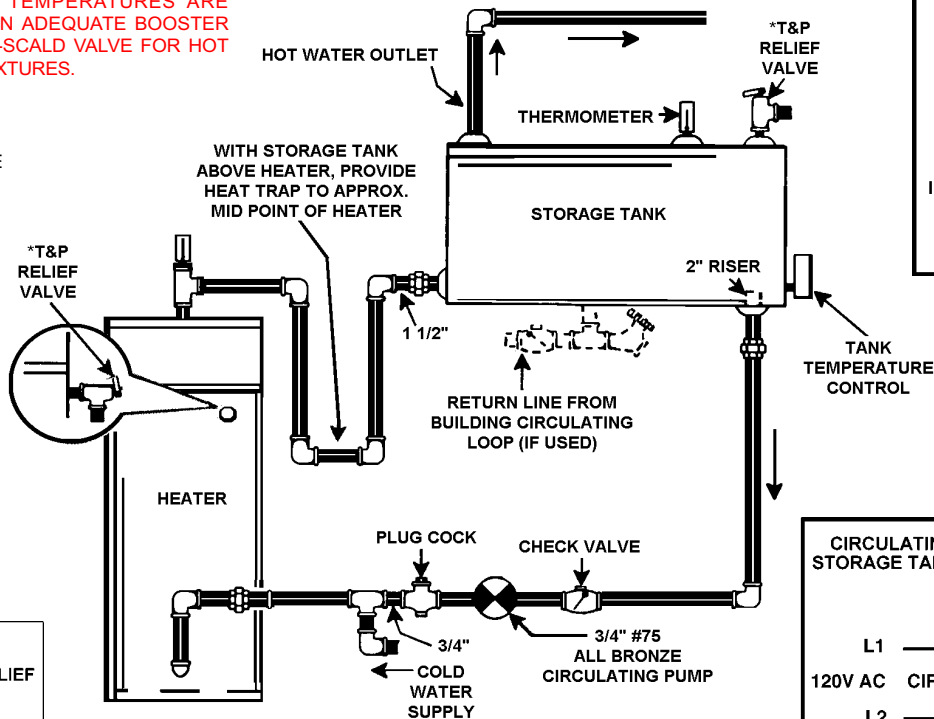
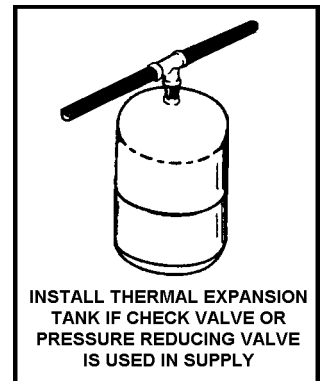

WIRING DIAGRAM FOR BOILER TO TANK LOOP AND/OR HOT WATER LOOP (IF USED).

TWO TEMPERATURE - ONE HEATER HIGH TEMPERATURE WITH OR WITHOUT BUILDING RECIRCULATION

⚠ DANGER

TEMPERATURE SETTING SHOULD NOT EXCEED SAFE TEMPERATURE AT FIXTURES. SEE WATER TEMPERATURE CONTROL WARNING ON PAGE 4. IF HIGHER PREHEAT TEMPERATURES ARE NECESSARY TO OBTAIN ADEQUATE BOOSTER OUTPUT, ADD AN ANTI-SCALD VALVE FOR HOT WATER SUPPLIED TO FIXTURES.

CAUTION: IF BUILDING COLD WATER SUPPLY HAS A BACK-FLOW PREVENTER, CHECK VALVE OR WATER METER WITH CHECK VALVE PROVISIONS FOR THERMAL EXPANSION OF WATER IN THE HOT WATER SYSTEM MUST BE PROVIDED.

*PIPE RELIEF VALVE TO OPEN DRAIN.

NOTE: IF TEMPERED WATER IS RECIRCULATED, RETURN LINE SHOULD BE CONNECTED AT POINT "A".

INSTALL IN ACCORDANCE WITH LOCAL CODES.

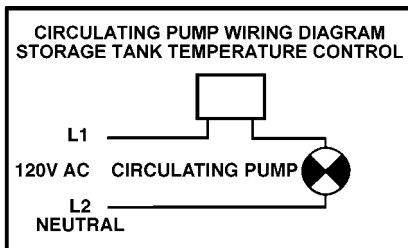
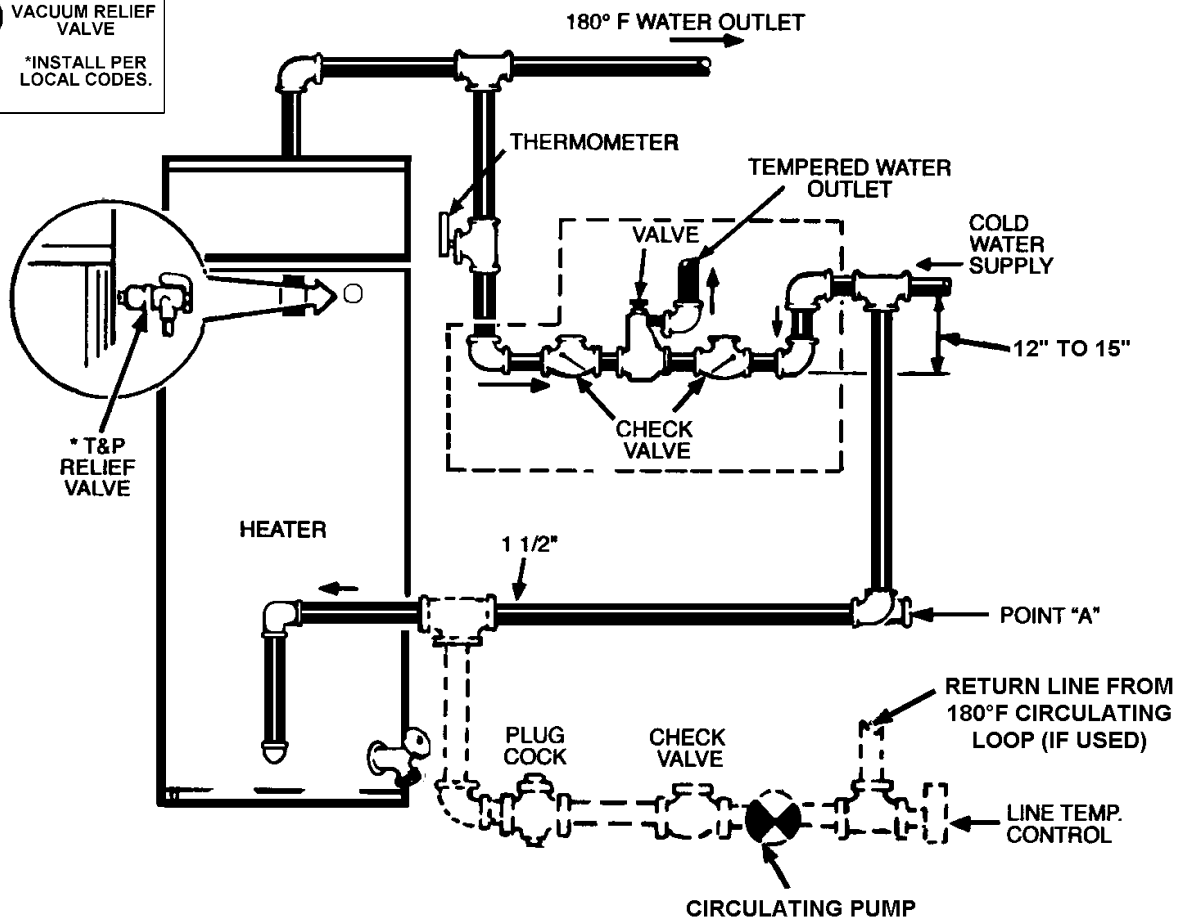
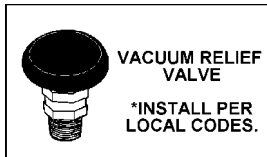
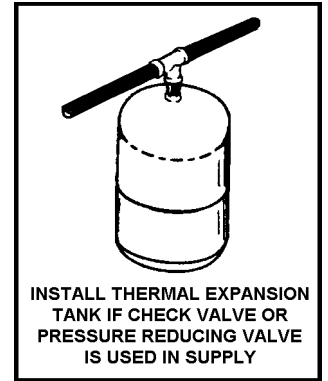

WIRING DIAGRAM FOR BOILER TO TANK LOOP AND/OR HOT WATER LOOP (IF USED).

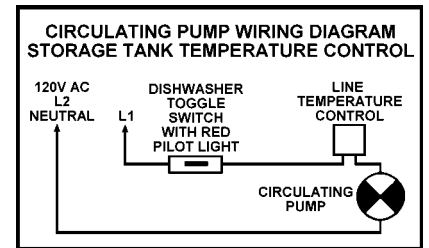

WIRING DIAGRAM FOR 180° LOOP (IF USED).

TWO TEMPERATURE - TWO HEATERS HIGH TEMPERATURE WITH OR WITHOUT BUILDING RECIRCULATION

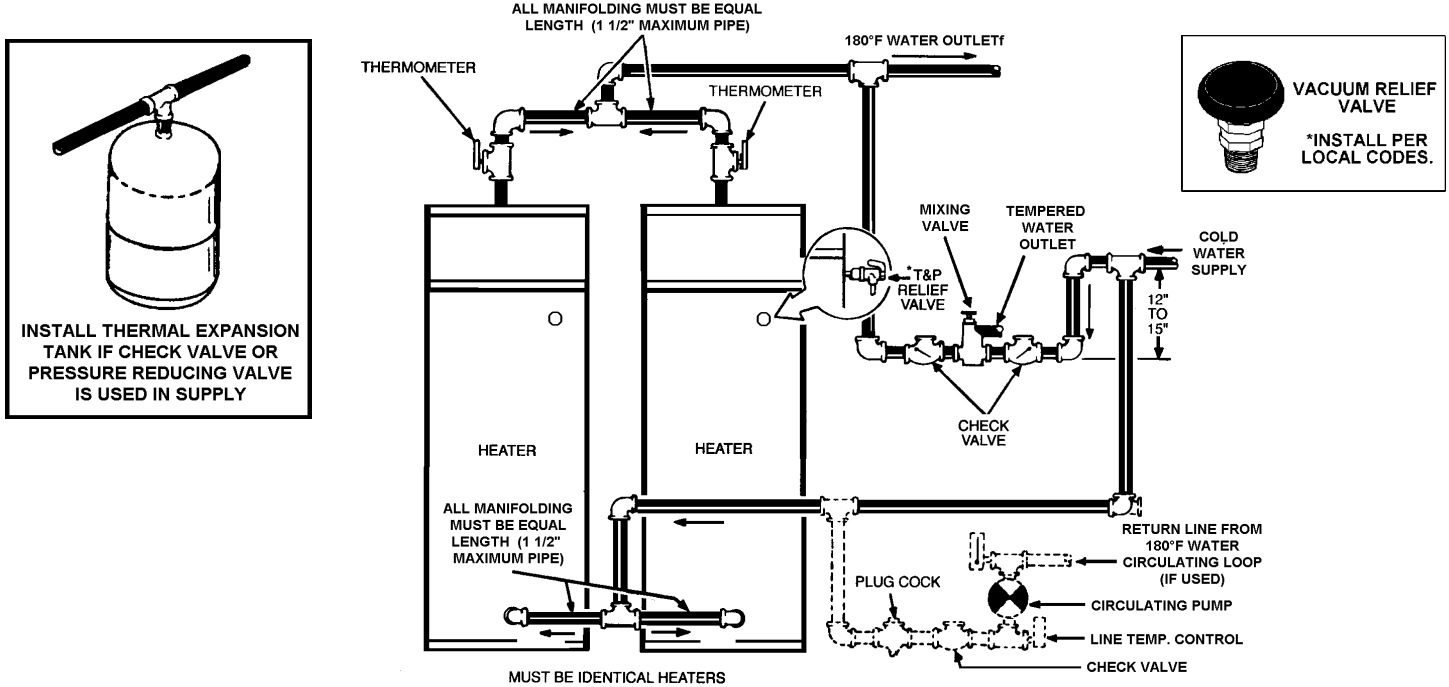

TWO TEMPERATURE - THREE HEATERS (TWO PRE-HEATERS/ONE BOOSTER HEATER) WITH OR WITHOUT BUILDING RECIRCULATION

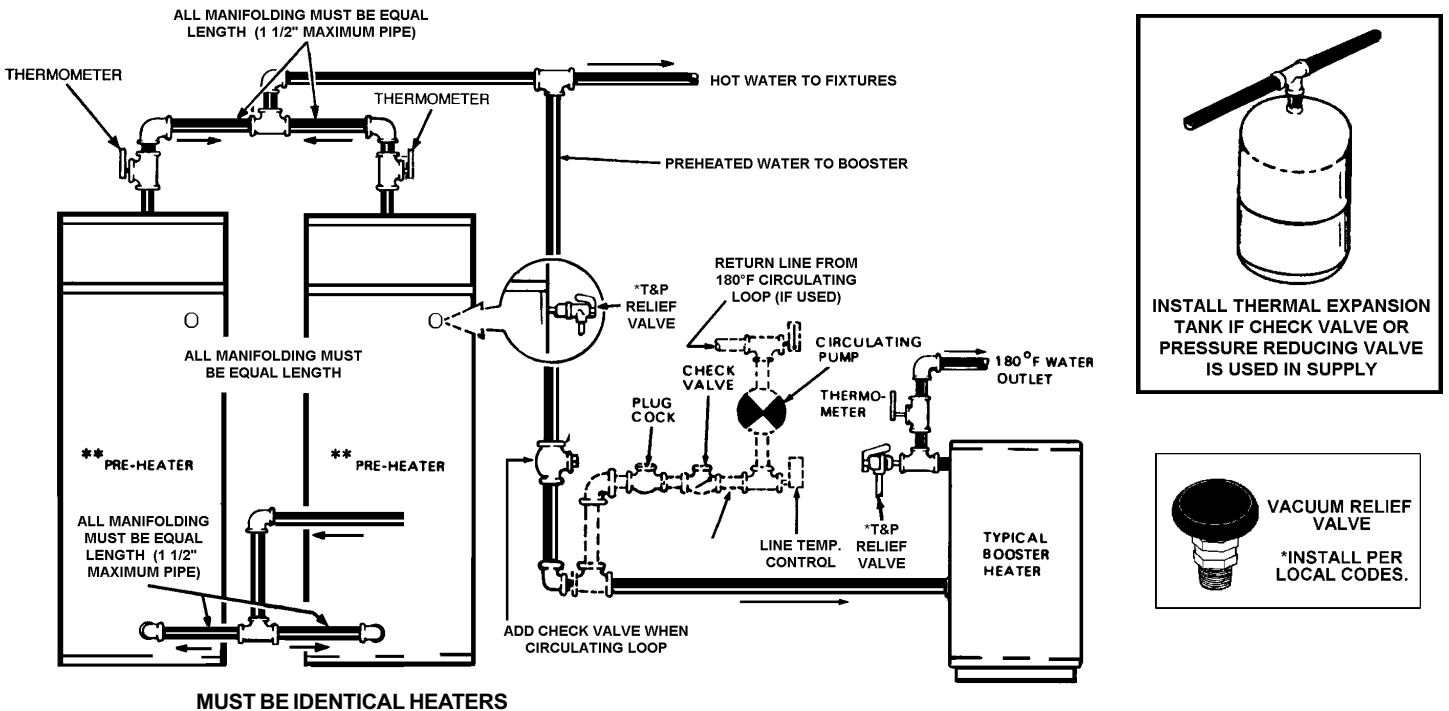

FOR MULTIPLE HEATER INSTALLATION SEE MANIFOLD KIT SPECIFICATIONS, PAGE 28.

CAUTION: IF BUILDING COLD WATER SUPPLY HAS A BACK-FLOW PREVENTER, CHECK VALVE OR WATER METER WITH CHECK VALVE PROVISIONS FOR THERMAL EXPANSION OF WATER IN THE HOT WATER SYSTEM MUST BE PROVIDED.

! DANGER

TEMPERATURE SETTING SHOULD NOT EXCEED SAFE TEMPERATURE AT FIXTURES. SEE WATER TEMPERATURE CONTROL WARNING ON PAGE 4. IF HIGHER PREHEAT TEMPERATURES ARE NECESSARY TO OBTAIN ADEQUATE BOOSTER OUTPUT, ADD AN ANTI-SCALD VALVE FOR HOT WATER SUPPLIED TO FIXTURES.

TWO TEMPERATURE - TWO HEATERS (ONE PRE-HEATER/ONE BOOSTER HEATER) WITH OR WITHOUT BUILDING RECIRCULATION



TEMPERATURE SETTING SHOULD NOT EXCEED SAFE TEMPERATURE AT FIXTURES. SEE WATER TEMPERATURE CONTROL WARNING ON PAGE 4. IF HIGHER PREHEAT TEMPERATURES ARE NECESSARY TO OBTAIN ADEQUATE BOOSTER OUTPUT, ADD AN ANTI-SCALD VALVE FOR HOT WATER SUPPLIED TO FIXTURES

* PIPE RELIEF VALVE TO OPEN DRAIN

** 140°F TO 150°F SHOULD BE MAXIMUM WATER TEMPERATURE MAINTAINED IN THE PRE-HEATERS.

120°F SHOULD BE THE MINIMUM TEMPERATURE OF WATER IN THE PRE-HEATERS.

CONNECT CIRCULATING LINE FROM FIXTURES, IF USED, TO COLD WATER SUPPLY LINE OF PRE-HEATER.

CONNECT CIRCULATING LINE OF 180°F OR BOOSTED WATER, IF USED, TO INLET WATER LINE TO BOOSTER.

INSTALL IN ACCORDANCE WITH LOCAL CODES.

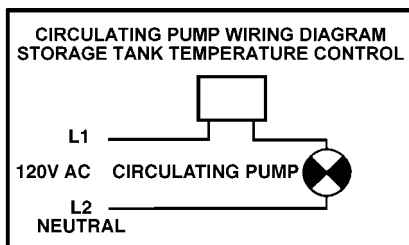
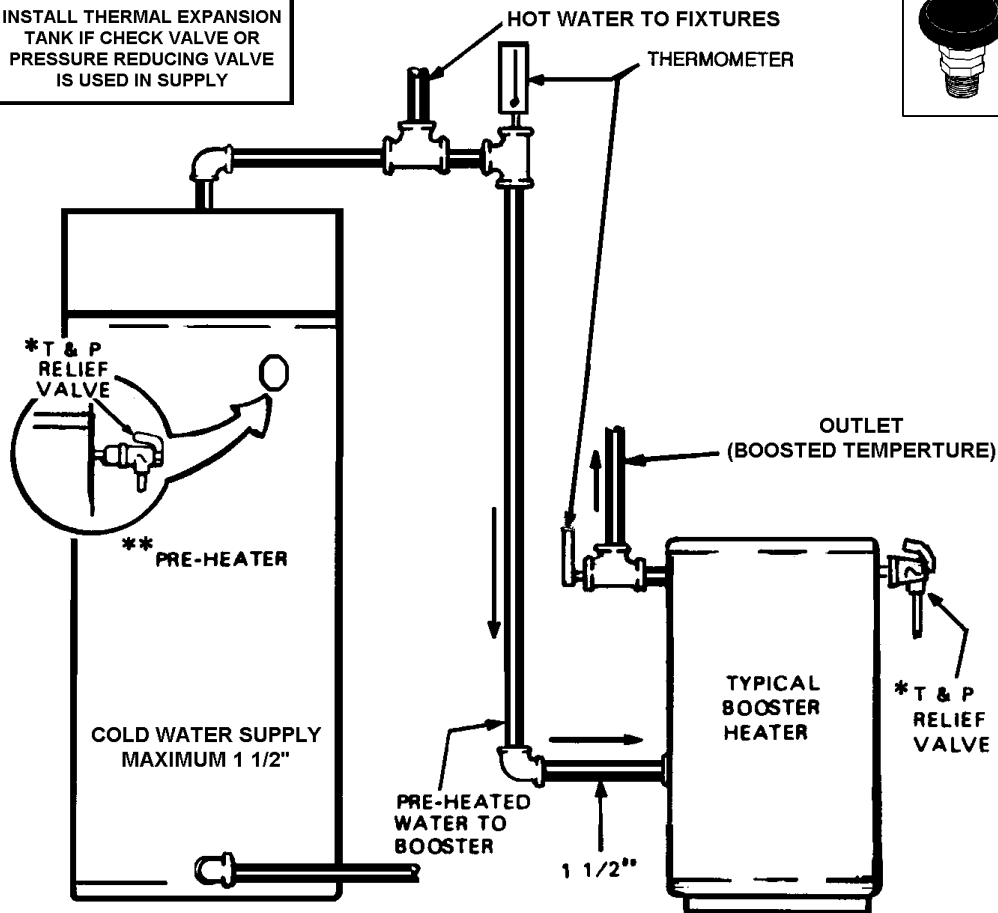
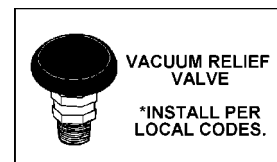
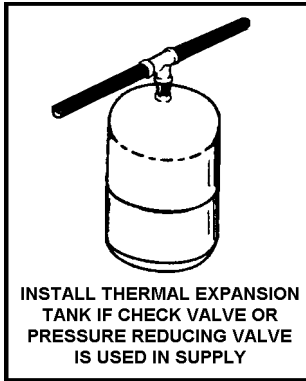

WIRING DIAGRAM FOR BOILER TO TANK LOOP AND/OR HOT WATER LOOP (IF USED).

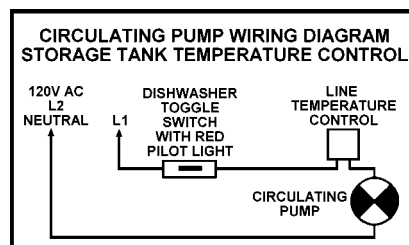

WIRING DIAGRAM FOR 180° LOOP (IF USED).

**TWO TEMPERATURE - ONE HEATER HIGH TEMPERATURE
WITH RECIRCULATION OF SANITIZING LOOP**

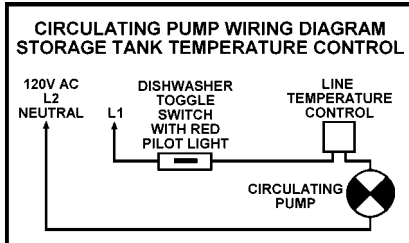

WIRING DIAGRAM FOR 180° LOOP (IF USED).

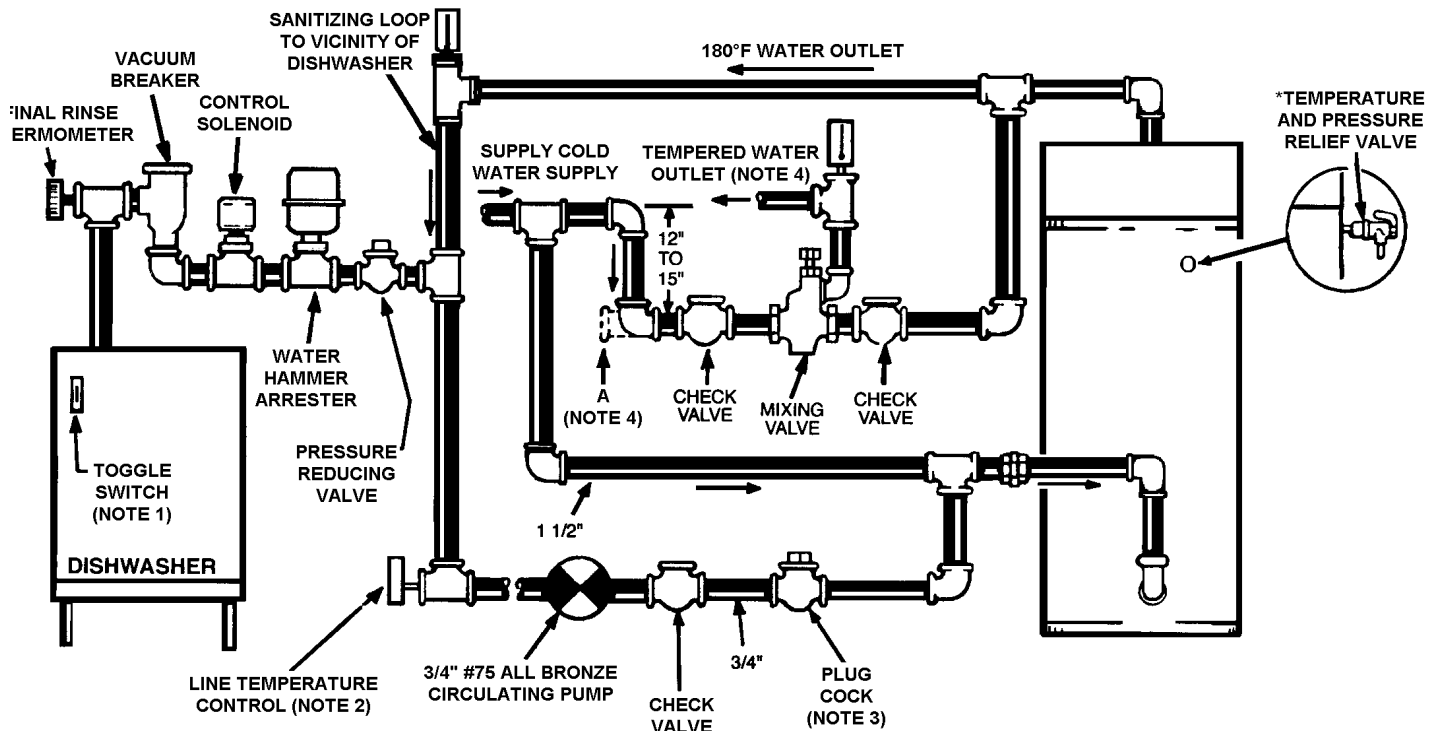
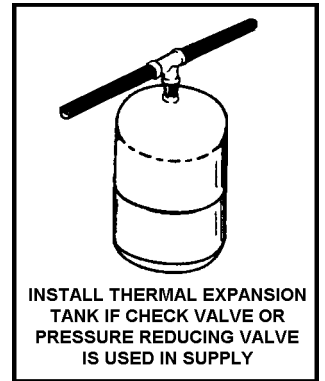
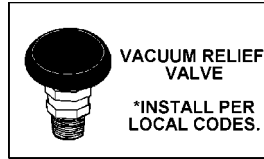

⚠ DANGER

TEMPERATURE SETTING SHOULD NOT EXCEED SAFE TEMPERATURE AT FIXTURES. SEE WATER TEMPERATURE CONTROL WARNING ON PAGE 5. IF HIGHER PREHEAT TEMPERATURES ARE NECESSARY TO OBTAIN ADEQUATE BOOSTER OUTPUT, ADD AN ANTI-SCALD VALVE FOR HOT WATER SUPPLIED TO FIXTURES.

CAUTION: IF BUILDING COLD WATER SUPPLY HAS A BACK-FLOW PREVENTER, CHECK VALVE OR WATER METER WITH CHECK VALVE PROVISIONS FOR THERMAL EXPANSION OF WATER IN THE HOT WATER SYSTEM MUST BE PROVIDED.

*PIPE RELIEF VALVE TO OPEN DRAIN

INSTALL IN ACCORDANCE WITH LOCAL CODES

NOTE 1: TOGGLE SWITCH CONTROLS 180°F WATER CIRCULATION. INSTALL ON OR CLOSE TO DISHWASHER. TOGGLE SWITCH MUST BE CLOSED (ON) DURING THE RINSE OPERATION AND OPEN (OFF) WHEN DISHWASHER IS NOT OPERATING OR WHEN ON LONG STANDBY.

NOTE 2: INSTALL LINE TEMPERATURE CONTROL IN AN UNINSULATED TEE BEYOND THE DISHWASHER TAKEOFF IN THE SANITIZING LOOP. CONTROL SHOULD BE SET AT 185°F.

NOTE 3: ADJUST PLUG COCK SO THE SANITIZING LOOP FLOW RATE DOES NOT CAUSE UNNECESSARY TURBULENCE IN THE TANK.

NOTE 4: IF TEMPERED WATER IS RECIRCULATED, RETURN LINE SHOULD BE CONNECTED AT POINT A.

MANIFOLD KITS

Precision cut type "L" all copper A.O. Smith manifold kits assure water flow balance of all units. Without this balance, the full water heating and storage potential of the system cannot be achieved. Plus, the units with the higher water flow may have a shortened life. Unions shown in piping diagrams are not included in the manifold kits.

Dimensions shown are for minimum space occupied by the water heaters assemblies.

Space for the venting system and unit servicing must be added.

**TWO UNIT MANIFOLD KIT
(PART NO. 78692)**

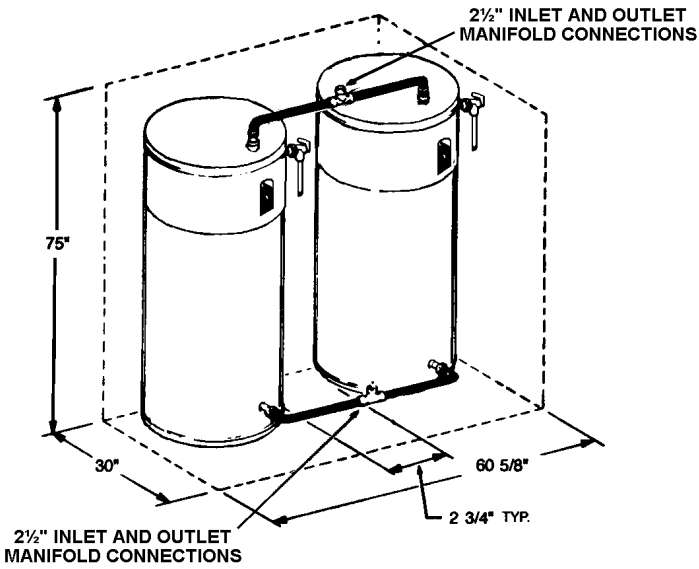

**THREE UNIT MANIFOLD KIT
(PART NO. 78693)**

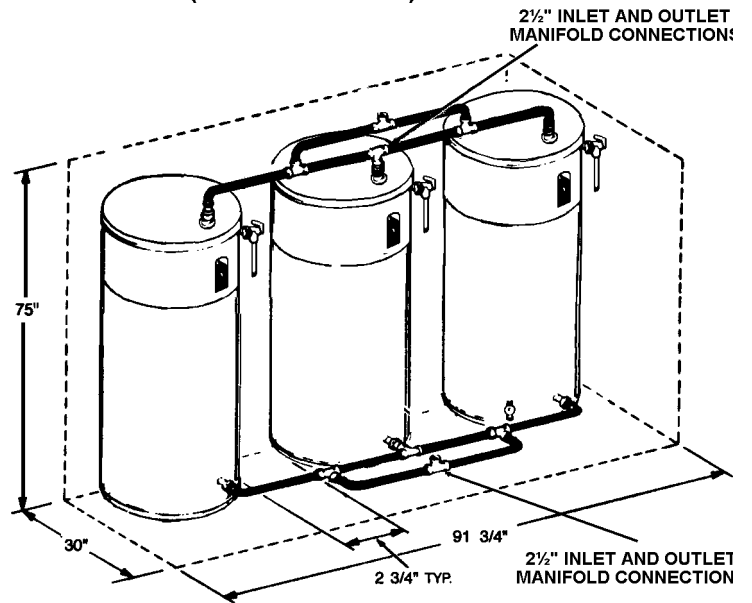

**FOUR UNIT MANIFOLD KIT
(PART NO. 78694)**

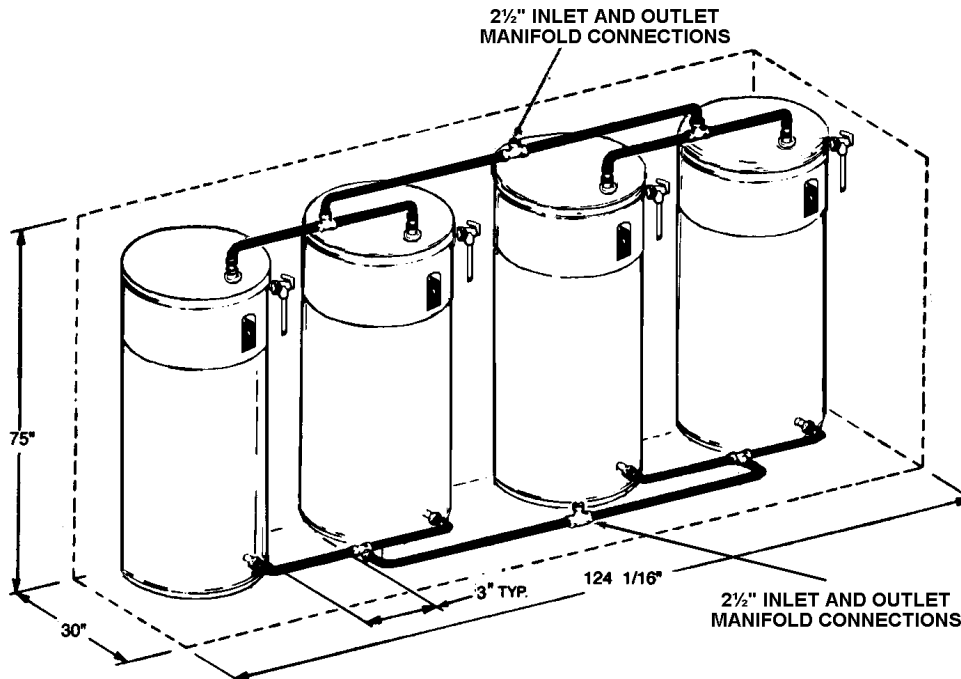

CHECKLIST AND SERVICE INFORMATION

IMPORTANT

The installer may be able to observe and correct certain problems which might arise when the unit is put into operation or when it is re-fired after a prolonged shutdown. HOWEVER, it is recommended that only qualified servicemen, using appropriate test equipment, be allowed to service the heater.

BE SURE TO TURN OFF THE ELECTRICITY WHENEVER POSSIBLE OR APPROPRIATE WHILE CHECKING EQUIPMENT.



WARNING

FAILURE TO FOLLOW THESE INSTRUCTIONS CAN RESULT IN SERIOUS PERSONAL INJURY OR DEATH.

CAUTION: LABEL ALL WIRES PRIOR TO DISCONNECTION WHEN SERVICING CONTROLS. WIRING ERRORS CAN CAUSE IMPROPER AND DANGEROUS OPERATION.

VERIFY PROPER OPERATION AFTER SERVICING.

BURNER OPERATIONAL PROBLEMS

1. Refer to TROUBLESHOOTING.

NOT ENOUGH OR NO HOT WATER

1. Be certain the electrical disconnect switch serving the water heater is in the ON position.
2. Check the fuses.
 - The electrical disconnect switch usually contains fuses.
3. The capacity of the heater may have been exceeded by a large demand for hot water.
 - Large demands require a recovery period to restore water temperature.
4. Colder incoming water temperature will lengthen the time required to heat water to the desired temperature.
 - If the heater was installed when incoming water temperature was warm, colder water creates the effect of less hot water.
5. Look for hot water wastage and leaking or open hot water faucets.
6. Sediment or lime scale may be affecting water heater operation. Refer to MAINTENANCE for details.
7. The heater's temperature high limit sensor has activated. Press the reset button on the thermostat.
8. Burner may not be firing at proper rate.
 - Check gas pressure. Adjust to obtain required manifold pressure.
9. Burner fan wheel may be dirty.
 - Clean fan wheel with a stiff brush.
10. Condensate hose may be blocked where it connects to the exhaust elbow.
 - Verify the condensate drains from the unit without restriction.

WATER IS TOO HOT

1. Refer to WATER TEMPERATURE CONTROL.

WATER HEATER MAKES SOUNDS

1. Sediment or lime scale accumulations cause rumbling and pounding noises when the heater is operating.

- The sounds are normal, however, the tank bottom should be cleaned. Refer to MAINTENANCE for details.

2. Some of the electrical components of the water heater make sounds which are normal.

- Contacts click or snap as the heater starts and stops.

- Transformers often hum.

WATER LEAKAGE IS SUSPECTED

1. Check to see if the water heater drain valve is tightly closed. Also check the cleanout opening for leakage.

2. The apparent leakage may be condensation which forms on cool surfaces of the heater and piping.

3. If the outlet of the relief valve is leaking it may represent:

- Excessive water pressure.

- Excessive water temperature.

- Faulty relief valve.

Excessive water pressure is the most common cause of relief valve leakage. It is often caused by a "closed system". If a check valve is in the inlet system it will not permit the expanded hot water volume to equalize pressure with the main. The relief valve must release this water or the water heater or plumbing system will be damaged. Refer to MAINTENANCE-RELIEF VALVE section in this manual.

When such a condition is encountered, local codes or inspection agency should be consulted to determine which system is acceptable in your area. See CLOSED SYSTEM section in this manual also.

TROUBLE-SHOOTING



WARNING

JUMPING OUT COMPONENTS AND/OR CIRCUITS DURING TROUBLESHOOTING CAN CAUSE SERIOUS PROBLEMS WITH THE UNIT'S OPERATING SEQUENCE AND IGNITION SAFETY. IF YOU DO NOT HAVE THE PROPER TEST EQUIPMENT, I.E. A VOLT-OHM METER AND A MICROAMMETER, DO NOT ATTEMPT TO TROUBLESHOOT OR REPAIR A.O. SMITH EQUIPMENT.

ALTERING THE CONTROLLER AND/OR CONTROLLER WIRING IN ANY WAY COULD RESULT IN INTERNAL DAMAGE TO THE MODULE CIRCUITS, POSSIBLY ALTERING THE IGNITION SEQUENCE ALLOWING GAS VALVES TO OPEN BEFORE THE HOT SURFACE IGNITER IS UP TO IGNITION TEMPERATURE.

NOTE: ANY BYPASS OR ALTERATION OF THE UNITS SAFETIES WILL RESULT IN VOIDING THE APPLIANCE WARRANTY.

Before performing any troubleshooting familiarize yourself with the particular appliance.

Refer to the SEQUENCE OF OPERATION and the connection diagram located on page 15 before continuing.

Make sure the appliance is connected to a 120V AC power supply, manual gas valve is in the ON position, and all electrical connections are secure before continuing to troubleshoot this appliance.



CAUTION

THE WATER HEATER IS POLARITY SENSITIVE. BEFORE APPLYING ELECTRICITY TO THIS HEATER BE CERTAIN THAT SUPPLY HEATED WIRE TO GROUND CHECK INDICATES ZERO VOLTAGE.

MOTOR WILL NOT RUN

1. Confirm 120V AC to the controller. Also, to verify correct polarity, check for 120 V AC between hot supply and ground.

If there is no voltage, check for a loose connection where it connects to the controller.

2. If there is 120 volts to the controller, check for loose connections or a locked rotor. If the rotor cannot be freed the motor and blower assembly must be replaced.

MOTOR RUNS, PREPURGE TIME ELAPSES BUT MAIN FLAME NOT ESTABLISHED.

1. Check to see if main manual gas valve is open.
2. Check for a loose connection at the transformer, or a defective transformer.
3. Check for a loose connection at the gas valve.
4. Check for open pressure switches or open reset button. Check for blockage in the intake and exhaust venting or at the vent hoods. If no blockage is found, check vinyl tubing for cuts or crimps. If this tubing is damaged it must be replaced. If these steps do not eliminate the problem, replace the pressure switches.
5. Check to see if there is resistance across the igniter terminal with an OHM meter. If there is no continuity, the igniter is broken and should be replaced.

If the igniter appears to function properly, then verify that the inlet pressure is 14.0" W.C. maximum. The gas valve supplied on this appliance is not designed to open against a higher pressure. At this time also check that the inlet pressure is not lower than the minimal gas supply pressure, as shown in Table 4: that is, for Natural Gas, 5.0" W.C. for BTH 120 & 250 or 4.5" W.C. for BTH 150 & 199 or; for L.P. Gas, 11.0" W.C. if the inlet pressure is not within these limits then adjust the supply pressure accordingly.

If the inlet pressure falls within the allowable limits, then verify that the manifold pressure, when the gas is fully open, with the heater running, is as called out in Table 4: that is, for Natural Gas, 4.0" W.C. for BTH 120 & 250 or 3.5" W.C. for BTH 150 & 199 or; for L.P. Gas, 10.0" W.C. If the manifold pressure is not correct then adjust accordingly. See ADJUSTMENT PROCEDURE in OPERATING INSTRUCTIONS selection, page 18, for the manifold pressure adjustment procedure.

6. If the inlet and manifold pressures are within the limits specified in step 5, then reset the appliance. Verify 24V AC at the gas valve during the three (3) second ignition trial, after the igniter reaches operating temperature. If 24V AC at the gas valve is not seen during this period, the controller must be replaced.

If there is 24V AC at the gas valve during the four second ignition trial and the manifold pressure does not increase above 0" W.C. then verify that the manual gas control valve is in the "ON" position (see page 20). If the valve is in the "ON" position and the previous voltage and gas pressure conditions are met, then the gas valve is defective and must be replaced.

Note that a positive manifold pressure reading of approximately 1.5" W.C. is normal during the prepurge portion of the ignition cycle due to the location of the gas orifice.

MOTOR RUNS, BURNER LIGHTS MOMENTARILY, THEN LOCKS OUT

1. Reset the appliance two more times to ensure that all of the air has been purged from the gas line.
2. If the burner lights momentarily but does not sustain ignition, verify that

the inlet pressure is not greater than 14.0" W.C. or lower than the minimal gas supply pressure, as shown in Table 4: that is, for Natural Gas, 5.0" W.C. for BTH 120 & 250 or 4.5" W.C. for BTH 150 & 199 or; for L.P. Gas, 11.0" W.C. pressure. Also, the manifold pressure should rise during the three (3) second trial for ignition to the manifold pressure value for the individual unit listed in Table 4: that is, for Natural Gas, 4.0" W.C. for BTH 120 & 250 or 3.5" W.C. for BTH 150 & 199 or; for L.P. Gas, 10.0" W.C. If the manifold pressure is not correct then adjust accordingly. See ADJUSTMENT PROCEDURE in OPERATING INSTRUCTIONS section, page 18, for the manifold pressure adjustment procedure.

3. Check for the reversed polarity in the supply wiring. This controller is polarity sensitive. If the hot and neutral supply wires are reversed, the controller will not sense flame. Reverse the supply wires and try to fire the unit.

NOTE: Always turn off and disconnect main supply wiring before servicing the unit.

4. Check connecting wire to the flame sensor. Verify that the flame sensor has not been damaged in any way.
5. Verify that the air supply is adequate. The air inlet screen or blower wheel may be restricted. Also, check the installation for proper ventilation. See AIR REQUIREMENTS.
6. Check the venting system for the correct sizing, excess or insufficient. See VENTING.
7. Check for a maximum inlet pressure of 14.0" W.C. and the manifold pressure as listed in Table 4: that is, for Natural Gas, 4.0" W.C. for BTH 120 & 250 or 3.5" W.C. for BTH 150 & 199 or; for L.P. Gas, 10.0" W.C. Please note that the manifold pressure listed is the maximum value for the manifold pressure. Do not set the manifold pressure higher than the value shown for your heater in Table 4. Overfiring the heater will result in rough ignition and/or noisy operation.
8. Confirm that the air inlet screen (see Figures 7 & 8) is free of obstructions.

CAUTION

Do not reach into the burner housing or combustion chamber if the heater is still hot. Allow the heater to cool and always use gloves as the combustion chamber and the burner sleeve and housing can become very hot after operation. Overfiring is a dangerous condition that must be corrected immediately.

NOISY BURNER OPERATION

The exhaust of this unit produces some noise. This noise may be objectionable if the exhaust terminal is located too close to the opening of an occupied space. The noise may also be objectionable if the exhaust is located in the confined space between two buildings such as an alley or walkway. Since everyone's perception and tolerance for background noise varies, there is no standard recommendation. The best option when the noise is a concern is to locate the exhaust as far away from any occupied spaces as practical.

If noise becomes more than one can tolerate, a dampening muffler is available through our Product Service Division. See "REPLACEMENT PARTS" segment below.

GAS FAILS TO SHUT OFF

Check for defective gas valve or thermostat. If operation is incorrect, replace.

REPLACEMENT PARTS

Replacement parts may be ordered through A.O. Smith dealers, authorized servicers or distributors. Refer to the Yellow Pages for where to call or contact the A.O. Smith Water Products Company, 5621 W. 115th Street, Alsip, IL 60482, 1-800-433-2545. When ordering parts be sure to state the quantity, part number and description of the items including the complete model and serial number as it appears on the product. Refer to the parts list for more information.

Model BTH Limited Warranty

A. O. Smith Corporation, the warrantor, extends the following LIMITED WARRANTY to the owner of this water heater.

1. THE TANK

If the glass-lined tank in this water heater shall prove upon examination by the warrantor to have leaked due to natural corrosion from potable water therein, during the first THREE years after initial installation, the warrantor will supply a replacement tank less burner and controls or a complete new A.O. Smith water heater of equivalent size and current model at the warrantor's option. Some government agencies are requiring energy efficient standards for water heaters. In the event regulations prohibit sale of a model of equivalent size and construction, A.O. Smith will provide a model which complies with the regulations of your area., in which case the consumer will be charged the difference in price between the like replacement and the energy efficient model required. The warranty on the replacement water heater will be limited to the unexpired term of the original warranty.

2. ALL OTHER PARTS

If within ONE year after initial installation of this water heater, any part or portion shall prove upon examination by the warrantor to be defective in material or workmanship, the warrantor will repair or replace such part or portion at its option.

3. CONDITIONS AND EXCEPTIONS

This warranty shall apply only when the water heater is installed in accordance with local plumbing and building codes, ordinances and regulations, the printed instructions provided with it and good industry practices. In addition, a temperature and pressure relief valve, certified by A.G.A. and approved by the American Society of Mechanical Engineers, must have been installed.

a. This warranty shall apply only when the heater is used:

- (1) at temperatures not exceeding the maximum setting of its thermostat;
- (2) at water pressure not exceeding the working pressure shown on the heater;
- (3) when operated free of the damaging effects of uncontrolled water hammer;
- (4) when filled with potable water, free to circulate at all times;
- (5) in a non-corrosive and non-contaminated atmosphere;
- (6) with factory approved anode(s) installed;
- (7) in the United States, its territories or possessions, and Canada;

b. Any accident to the boiler, any misuse, abuse (including freezing) or alteration of it, any operation of it in a modified form, or any attempt to repair tank leaks will void this warranty.

c. This warranty is void if a device acting as a backflow prevention device (check valves etc.) is installed in the cold water supply the heater is connected to, unless an effective method of controlling thermal expansion is also installed at the heater(s) and operational at all times. The relieve valve installed on the heater is not an acceptable method.

4. SERVICE AND REPAIR EXPENSES

Under the limited warranty the warrantor will provide only a replacement water heater or part thereof. The owner is responsible for all other costs. Such costs may include but are not limited to:

- a. Labor charges for service removal, repair or reinstallation of the water heater or any component part;
- b. Shipping, delivery, handling, and administrative charges for forwarding the new heater or replacement part from the nearest distributor and returning the claimed defective heater or part to such distributor.
- c. All cost necessary or incidental for any material and/or permits required for installation of the replacement.

5. LIMITATIONS ON IMPLIED WARRANTIES

Implied warranties, including the warranty of merchantability imposed on the sale of this heater under state law are limited to one (1) year duration for the heater or any of its parts. Some states do not allow limitations on how long an implied warranty lasts, so the above limitation may not apply to you.

6. CLAIM PROCEDURE

Any claim under the warranty should be initiated with the dealer who sold the boiler, or with any other dealer handling the warrantor's products.

If this is not practicable, the owner should contact:

U.S. Customers

A. O. Smith Corporation
5621 W. 115th Street
Alsip, IL 60803
Telephone: 1-(800)-323-2636

Canadian Customers

A. O. Smith Enterprises Ltd.
P. O. Box, 310 - 768 Erie Street
Stratford, Ontario N5A 6T3
Telephone: (519) 271-5800

a. The warrantor will only honor replacement with identical or similar water heater or parts thereof which are manufactured or distributed by the warrantor.

b. Dealer replacements are made subject to in-warranty validation by warrantor.

7. DISCLAIMERS

NO OTHER EXPRESS WARRANTY HAS BEEN OR WILL BE MADE IN BEHALF OF THE WARRANTOR WITH RESPECT TO THE HEATER OR THE INSTALLATION, OPERATION, REPAIR OR REPLACEMENT OF THE BOILER. THE WARRANTOR SHALL NOT BE RESPONSIBLE FOR WATER DAMAGE, LOSS OF USE OF THE UNIT, INCONVENIENCE, LOSS OR DAMAGE TO PERSONAL PROPERTY OR OTHER CONSEQUENTIAL DAMAGE. THE WARRANTOR SHALL NOT BE LIABLE BY VIRTUE OF THIS WARRANTY OR OTHERWISE FOR DAMAGE TO ANY PERSONS OR PROPERTY, WHETHER DIRECT OR INDIRECT, AND WHETHER ARISING IN CONTRACT OR TORT.

a. Some states do not allow the exclusion or limitation of the incidental or consequential damage, so the above limitations or exclusions may not apply to you.

b. This warranty gives you specific legal rights, and you may also have other rights which vary from state to state.

Fill in the following for your own reference. Keep it. Registration is not a condition of warranty. The model and serial number are found on the heater's rating plate.

Date Installed _____ Model No. _____ Serial No. _____

Dealer's Name _____ Phone No. _____

Dealer's Address _____ City and State _____ Zip Code _____

FILL IN WARRANTY AND KEEP FOR FUTURE REFERENCE.



A.O. SMITH
WATER PRODUCTS
COMPANY
PSD / Alsip, IL

A.O. SMITH WATER PRODUCTS CO., INC.
5621 W. 115TH STREET • ALSIP, ILLINOIS 60803
PHONE: 1-800-433-2545 • FAX: 1-800-433-2515
WWW.HOTWATER.COM • E-MAIL: PARTS@HOTWATER.COM