

AOS PREFERRED-BPD 400 DIRECT VENT

COMMERCIAL GAS WATER HEATER



**GAS-FIRED INDUCED DRAFT
FOR DOMESTIC HOT WATER**



• INSTALLATION • OPERATION • SERVICE • MAINTENANCE • LIMITED WARRANTY

⚠ WARNING: If the information in these instructions is not followed exactly, a fire or explosion may result causing property damage, personal injury or death.

- Do not store or use gasoline or other flammable vapors and liquids in the vicinity of this or any other appliance.
- **WHAT TO DO IF YOU SMELL GAS:**
 - Do not try to light any appliance.
 - Do not touch any electrical switch; do not use any phone in your building.
 - Immediately call your gas supplier from a neighbor's phone. Follow the gas supplier's instructions.
 - If you cannot reach your gas supplier, call the fire department.
- Installation and service must be performed by a qualified installer, service agency or the gas supplier.

Thank you for buying this energy efficient water heater from A.O. Smith Water Products Company. We appreciate your confidence in our products.

⚠ CAUTION

TEXT PRINTED OR OUTLINED IN RED CONTAINS INFORMATION RELATIVE TO YOUR SAFETY. PLEASE READ THOROUGHLY BEFORE INSTALLING AND USING THIS APPLIANCE.

PLACE THESE INSTRUCTIONS ADJACENT TO HEATER AND NOTIFY OWNER TO KEEP FOR FUTURE REFERENCE.

PRINTED IN U.S.A. 0206



A.O. Smith Water Heaters

A DIVISION OF A.O. SMITH CORPORATION
Mc BEE, SOUTH CAROLINA

Part Number 197279-000

ROUGH-IN DIMENSIONS

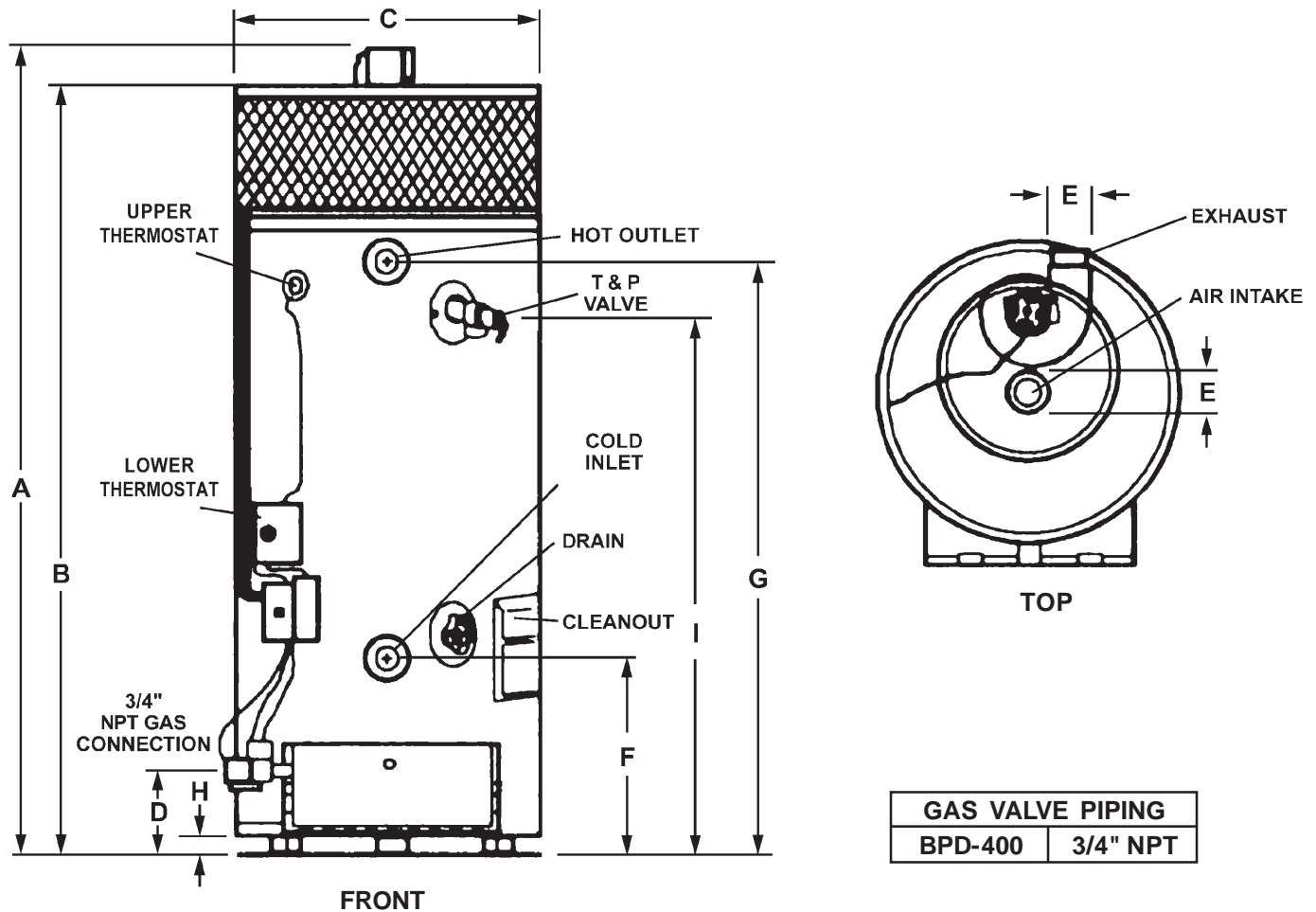

Model	Input BTU (kw-Hr.)	Capacity Gallon (Liters)	DIMENSIONS IN INCHES (CM)									GAS LINE	SHIPPING WEIGHT	
			"A"	"B"	"C"	"D"	"E"	"F"	"G"	"H"	"I"		STD	ASME
BPD - 400	390,000	95	82.25	80.25	30.25	8.75	4 or 6	21.75	63.50	2.25	58.00	1.00	900 lbs.	1100 lbs.
	(114.3)	(360)	(209)	(204)	(77)	(22)	vent	(55)	(161)	(8)	(147)	(2.54)	408 Kg	499 Kg

Table 1. RECOVERY CAPACITIES - NATURAL GAS

Model	Input BTU (kw-Hr.)	Capacity Gallon (Liters)	TEMPERATURE RISE - DEGREES F - GALLONS PER HOUR (LPH)											
			30 F 17 C	40 F 22 C	50 F 28 C	60 F 33 C	70 F 39 C	80 F 44 C	90 F 50 C	100 F 56 C	110 F 61 C	120 F 67 C	130 F 72 C	140 F 78 C
BPD - 400	390,000	95	1316	987	789	658	564	493	439	395	359	329	304	282
	(114.3)	(360)	(4981)	(3735)	(2988)	(2490)	(2135)	(1868)	(1660)	(1494)	(1358)	(1245)	(1149)	(1067)

Recovery capacities are based on heater performance at 83.5% thermal efficiency.

TYPICAL INSTALLATION

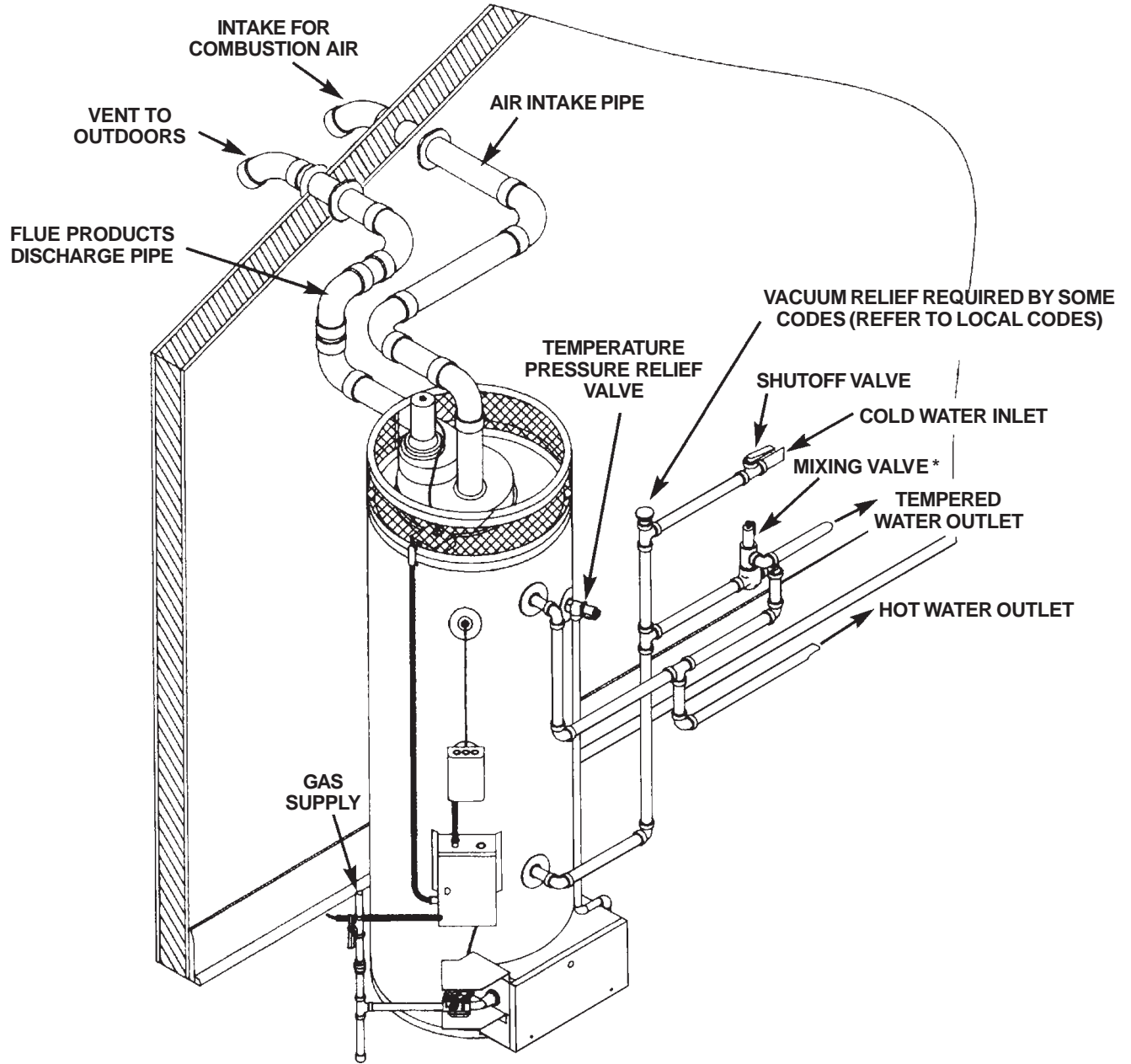

Installation Information: for Model BPD 400 100 Series

ELECTRICAL			CLEARANCES			PRESSURES		ORIFICES		INPUT	
120/24VAC	60Hz	5A	FRONT	SIDES	TOP		NATURAL		NATURAL	NATURAL	390kbtuh
UNIT IS POLARITY SENSITIVE			6"=(15 cm)	0"	12"=(30.5 cm)	Manifold	4.50" WC	Sea Level	0.126		
						Inlet	7.00" WC	4500'	0.126		
						Max. Inlet	14.00" WC	8000'	0.106		

FOREWORD

These designs comply with the current version of the American National Standard for Gas Water Heaters, Volume III, ANSI Z21.10.3 / CSA 4.3 as automatic circulating tank water heaters, and automatic storage water heaters.

Detailed installation diagrams are found in this manual. These diagrams will serve to provide the installer with a reference for the materials and methods of piping necessary. It is highly essential that all water, gas piping and wiring be installed as shown on the diagrams.

Particular attention should be given to the installation of thermometers at the locations indicated on the diagrams as these are necessary for checking the proper functioning of the heater.

In addition to these instructions, the equipment shall be installed in accordance with those installation regulations in force in the local area where the installation is to be made. These shall be carefully followed in all cases. Authorities having jurisdiction should be consulted before installations are made.

In the absence of local codes, the installation must comply with the current editions of the National Fuel Gas Code, ANSI Z223.1/NFPA 54 and the National Electric Code. The former is available from the Canadian Standards Association, 8501 East Pleasant Valley Road, Cleveland, OH 44131, and both documents are available from the National Fire Protection Association, 1 Batterymarch Park, Quincy, MA 02269.

TABLE OF CONTENTS

	PAGE		PAGE
ROUGH-IN DIMENSIONS	2	Filling the Water Heater	13
TYPICAL INSTALLATION	3	Wiring	13
FOREWORD	4	Venting	15
GENERAL SAFETY INFORMATION	5	Venting Through Roof	19
Precautions	5	GAS PIPING	20
Chemical Vapor Corrosion	5	Sediment Trap	20
Improper Combustion	5	INSTALLATION CHECKLIST	21
Extended Nonuse Periods	5	Operating Instructions for Model 100-400	22
Insulation Blankets	5	Operational Sequence (Natural Gas Models Only)	22
High Altitude Installations	5	Safety Sequence (Natural Gas Models Only)	22
FEATURES	6	Robertshaw Control System (Natural Gas)	22
The Eliminator	6	FOR YOUR SAFETY	23
High Limit Switch (E.C.O.)	6	Operating Instructions	23
Circulating Pump	6	To Turn Off Gas to Appliance	23
Dishwashing Machine Requirement	6	Temperature Regulation	24
Electronic Ignition Control	7	Temperature Adjustments	24
Pilot Assembly	7	START UP CONDITIONS	24
Gas Valve	7	Condensation	24
Pressure Switch	7	Smoke/Odor	25
Step Down Transformer	8	Thermal Expansion	25
Burner Tray Assembly	8	Strange Sounds	25
Burner Tray	8	OPERATIONAL CONDITIONS	25
Burner	8	Smelly Water	25
Burner Orifice	8	Air in Hot Water Faucets	25
Blower Assembly	8	Venting Manual Reset Switch	25
High Limit Switch	9	High Temperature Shut Off System	25
Shroud Assembly	9	E.C.O.	25
Temperature and Pressure Release Valve	9	Not Enough or No Hot Water	25
INSTALLATION INSTRUCTIONS	9	Water Is Too Hot	26
Required Ability	9	Venting System Inspection	26
Hard Water	9	Burner Inspection	26
Locating the Heater	9	Burner Cleaning	26
Leveling	9	Housekeeping	27
Clearances	10	Draining	27
Alcove Installation	10	Service	27
Air Requirements	10	INSTALLATION DIAGRAMS	28
COMBUSTION AIR AND EXHAUST	10	Manifold Kits	33
Venting Clearances	10	Sediment Removal	34
Facts to Consider About the Location	11	Lime Scale Removal	34
Wire Fence	11	Anode Inspection and Replacement	34
Water Piping	12	Replacement Parts	34
Temperature-Pressure Relief Valve	12	MODEL BPD 400 LIMITED WARRANTY	35

GENERAL SAFETY INFORMATION

PRECAUTIONS

DO NOT USE THIS APPLIANCE IF ANY PART HAS BEEN UNDER WATER. Immediately call a qualified service technician to inspect the appliance and to replace any part of the control system and any gas control which has been under water.

IF THE UNIT IS EXPOSED TO THE FOLLOWING, DO NOT OPERATE HEATER UNTIL ALL CORRECTIVE STEPS HAVE BEEN MADE BY A QUALIFIED SERVICEMAN.

1. EXTERNAL FIRE.
2. DAMAGE.
3. FIRING WITHOUT WATER.
4. SOOTING.

CHEMICAL VAPOR CORROSION



CORROSION OF THE FLUE AND VENT SYSTEM MAY OCCUR IF AIR FOR COMBUSTION CONTAINS CERTAIN CHEMICAL VAPORS. SUCH CORROSION MAY RESULT IN FAILURE AND RISK OF ASPHYXIATION.

Spray can propellants, cleaning solvents, refrigerator and air conditioning refrigerants, swimming pool chemicals, calcium and sodium chloride (water softener salt), waxes, and process chemicals are typical compounds which are potentially corrosive. Do not store products of this sort near the heater. Also, air which is brought in contact with the heater should not contain any of these chemicals. If necessary, uncontaminated air should be obtained from remote or outside sources. The limited warranty is voided when failure of water heater is due to a corrosive atmosphere. (Refer to the limited warranty for complete terms and conditions.)

IMPROPER COMBUSTION



ATTIC AND/OR EXHAUST FANS OPERATING ON THE PREMISES WITH A WATER HEATER CAN RESULT IN CARBON MONOXIDE POISONING AND DEATH.

OPERATION OF THESE FANS CAN PRODUCE A NEGATIVE DRAFT IN THE AREA OF THE WATER HEATER PREVENTING THE PRODUCTS OF COMBUSTION FROM EXHAUSTING THROUGH THE CHIMNEY OR VENT PIPE.

The venting of the water heater should be inspected by a qualified service technician at the time of installation and periodically thereafter to ensure a down-draft condition does not exist.

DO NOT OBSTRUCT THE FLOW OF COMBUSTION AND VENTILATING AIR. ADEQUATE AIR FOR COMBUSTION AND VENTILATION MUST BE PROVIDED FOR SAFE OPERATION.

EXTENDED NONUSE PERIODS



HYDROGEN GAS CAN BE PRODUCED IN A HOT WATER SYSTEM

SERVED BY THIS HEATER THAT HAS NOT BEEN USED FOR A LONG PERIOD OF TIME (GENERALLY TWO WEEKS OR MORE). HYDROGEN GAS IS EXTREMELY FLAMMABLE. To reduce the risk of injury under these conditions, it is recommended that the hot water faucet be opened for several minutes at the kitchen sink before using any electrical appliance connected to the hot water system. If hydrogen is present, there will probably be an unusual sound such as air escaping through the pipe as the water begins to flow. **THERE SHOULD BE NO SMOKING OR OPEN FLAME NEAR THE FAUCET AT THE TIME IT IS OPEN.**

INSULATION BLANKETS

Insulation blankets available to the general public for external use on gas water heaters are not approved for use on your A.O. Smith water heater. The purpose of an insulation blanket is to reduce the standby heat loss encountered with storage tank water heaters. Your A.O. Smith water heater meets or exceeds the ASHRAE/IES 90.1b-1999 standards with respect to insulation and standby loss requirement making an insulation blanket unnecessary.



Should you choose to apply an insulation blanket to this heater, you should follow these instructions. Failure to follow these instructions can result in fire, asphyxiation, serious personal injury or death.

- **Do not** apply insulation to the top of the water heater, as this will interfere with safe operation of venting components.
- **Do not** cover the gas valve or temperature & pressure relief valve.
- **Do not** cover the instruction manual. Keep it on the side of the water heater or nearby for future reference.
- **Do not** allow insulation to come within 2" (5 cm) of the burners, to prevent blockage of combustion air flow to the burners.
- **Do not** allow insulation to come within 9" (23 cm) of floor, (within 2" (5cm) of bottom cover) to prevent blockage of combustion air flow to the burners.
- **Do** inspect the insulation blanket frequently to make sure it does not sag, thereby obstructing combustion air flow.
- **Do** obtain new labels from A.O. Smith for placement on the blanket directly over the existing labels.

HIGH ALTITUDE INSTALLATIONS



INSTALLATIONS ABOVE 2000 FEET (610 METERS) REQUIRE REPLACEMENT OF THE BURNER ORIFICES IN ACCORDANCE WITH SECTION 8.1.2 OF THE NATIONAL FUEL GAS CODE (ANSI Z223.1). FAILURE TO REPLACE THE ORIFICES WILL RESULT IN IMPROPER AND INEFFICIENT OPERATION OF THE APPLIANCE RESULTING IN THE PRODUCTION OF INCREASED LEVELS OF CARBON MONOXIDE GAS IN EXCESS OF SAFE LIMITS WHICH COULD RESULT IN SERIOUS PERSONAL INJURY OR DEATH.

You should contact your gas supplier for any specific changes which may be required in your area.

As elevation above sea level is increased, there is less oxygen per cubic

foot of air. Therefore, the heater input rate should be reduced at high altitudes for satisfactory operation with the reduced oxygen supply. Failure to make this reduction would result in an over-firing of the heater causing sooting, poor combustion and/or unsatisfactory heater performance.

Ratings specified by manufacturers for most appliances apply for elevations up to 2000 feet (610 m). For elevations above 2000 feet (610), ratings must be reduced at the rate of 4% for each 1000 feet (305m) above sea level. For example, if a heater is rated at 120,000 Btuh (35 Kwh) at sea level, to rate the heater at 4000 feet (1219 m), you subtract 4 (once for each thousand feet) x 04 (4% input reduction) x 120,000 (original rating) from the original rating. Therefore, to calculate the input rating at 4,000 feet (121.9 m): $4 \times .04 \times 120,000 = 19,200$ Btuh (5.6 Kwh), $120,000$ (35 Kwh) - $19,200$ (5.6 Kwh) = $100,800$ Btuh (29.4 Kwh). At 6000 feet (1829 m) the correct input rating should be $91,200$ Btuh (26.7 Kwh).

Field conversion is not permitted.

FEATURES

THE ELIMINATOR (SELF-CLEANING SYSTEM)

These units include The Eliminator (Self-Cleaning System) installed in the front water inlet, see Figure 2. The Eliminator must be oriented correctly for proper function. There is a marked range on the pipe nipple portion of the Eliminator, that must be aligned with the top of the inlet spud. A label above the jacket hole has an arrow that will point to the marked portion of the pipe nipple if the orientation is correct. If the arrow does not point within the marked range on the pipe nipple, adjust the pipe nipple to correct. A pipe union is supplied with the Eliminator to reduce the probability of misaligning the Eliminator accidentally while tightening the connection to the inlet water supply line. Improper orientation of the Eliminator can cause poor performance of the heater and can significantly reduce outlet water temperatures during heavy draws.

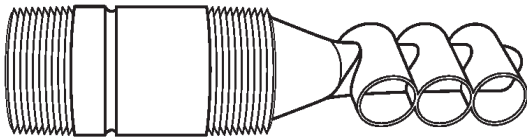

FIGURE 1

HIGH LIMIT SWITCH (E.C.O.)

The dual bulb controller contains the high limit (energy cutoff) sensor, see Figure 2. The high limit switch interrupts main burner gas flow should the water temperature reach 205°F (96°C).

In the event of high limit switch operation, the appliance cannot be restarted unless the water temperature is reduced by at least 20°F (11°C) and the high limit reset button on front of limit control is depressed, see Figure 2.

Continued manual resetting of high limit control, preceded by higher than usual water temperature is evidence of high limit switch operation. The following is a possible reason for high limit switch operation.

- A malfunction in the thermostatic controls could allow the gas valve to remain open causing water temperature to exceed the thermostat setting. The water temperature would continue to rise until high limit switch operation.

Contact your dealer or servicer if continued high limit switch operation occurs.

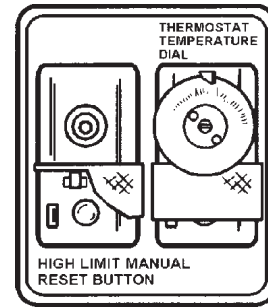
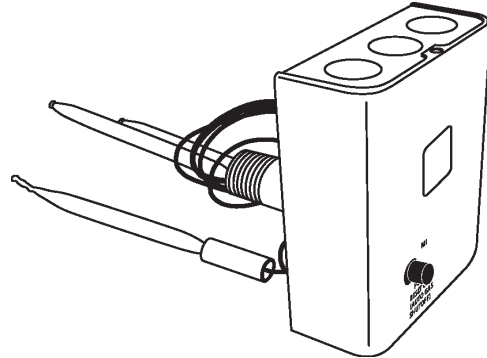

DUAL-BULB THERMOSTAT
(SHOWN AT TOP WITH COVER ON AND AT BOTTOM
WITH COVER REMOVED)

FIGURE 2

Continued pilot outage preceded by higher than usual water temperature is evidence of high limit switch operation. Contact your dealer or servicer to determine the reason for operation.

CIRCULATING PUMP

A circulating pump is used when a system requires a circulating loop or there is a storage tank used in conjunction with the heater. Refer to the piping diagrams in this manual for electrical hookup information and install in accordance with the current version of the National Electric Code ANSI/NFPA No. 70.

Only all bronze circulators are used with commercial water heaters.

Although circulators are oiled and operated by the manufacturer some circulators must be oiled again before operating. Please refer to manufacturer's instructions.

DISHWASHING MACHINE REQUIREMENT

These appliances meet the National Sanitation Foundation Standard for sanitary installations when used with the following leg kits, Part No's. 6570-0 and 6570-7.

All dishwashing machines meeting the National Sanitation Foundation requirements are designed to operate with water flow pressures

between 15 and 25 psi (103 kPa and 173 kPa). Flow pressures above 25 psi (173 kPa), or below 15 psi (103 kPa), will result in improperly sanitized dishes. Where pressures are high, a water pressure reducing or flow regulating control valve should be used in 180°F (82°C) line to the dishwashing machine, and should be adjusted to deliver water between these limits.

The National Sanitation Foundation also recommends circulation of 180°F (82°C) water. Where this is done, the circulation should be very gentle so that it does not cause any unnecessary turbulence inside the water heater. The circulation should be just enough to provide 180°F (82°C) water at the point of takeoff to the dishwashing machine. Adjust flow by means of the plug cock in the circulating line.



ROBERTSHAW 47484A PILOT SENSOR

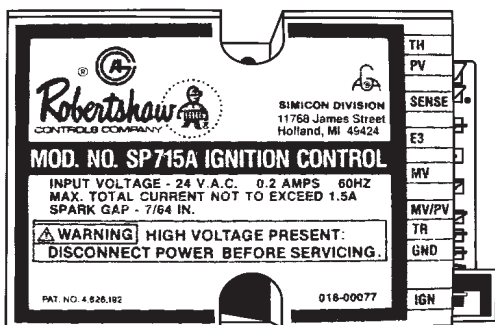

**FIGURE 3
ROBERTSHAW SP715A IGNITION CONTROL MODULE
NATURAL GAS MODEL**

ELECTRONIC IGNITION CONTROL

Each heater is equipped with an ignition control module (See figure 3 above). The solid state ignition control ignites the pilot burner gas by creating a spark at the pilot assembly. Pilot gas is ignited and burns during each running cycle. The main burner and pilot gases are cut off during the OFF cycle. Pilot operation is proven by the pilot sensor. Main burner ignition will not occur if the pilot sensor does not first sense pilot operation.

PILOT ASSEMBLY

The pilot assembly is mounted between the two middle burner assemblies in the combustion chamber. The ignition sequence begins with the ignition module sending voltage to the sparker located on the front side of the pilot hood. Pilot gas flow is initiated after the sparker begins to spark. The spark across the pilot gas flow ignites the pilot gas. Once the pilot gas is ignited, the flame sensor senses the flame through flame rectification (which means that the module's signal changes from an AC current to a DC current because the current can now flow through the flame to the pilot hood which is grounded to the unit). Once the sensor senses flame, the signal is sent back to the module to open up the gas valve for the main burners.

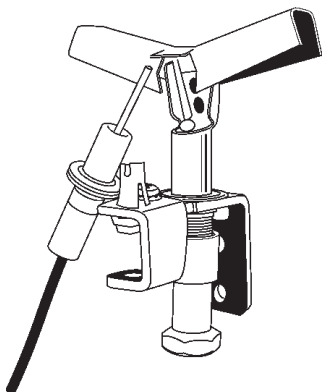

ROBERTSHAW #6S24-6 PILOT ASSEMBLY

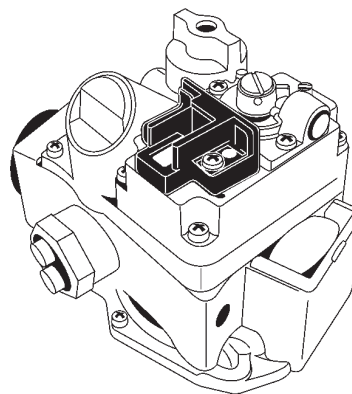

ROBERTSHAW DERHC-S7C NATURAL 1" x 1" GAS VALVE

GAS VALVE

The gas valve is used to supply the gas to the unit during heat up periods. The ignition control module monitors the thermostat's call for heat and sends a signal to the gas valve when to open to allow gas flow.

PRESSURE SWITCH

The Blocked Outlet/Prover switch is set up to shut the unit off when a pressure buildup in the exhaust vent pipe occurs. This switch is a negative pressure switch that requires an increase in negative pressure to change the electrical contacts from normally open to closed. The switch is connected to the pressure tap connected to the housing of the blower. When this switch prevents the unit from ignition, most likely the exhaust is blocked by some means. Check for obstructions in the exhaust vent terminal.

The Blocked Outlet/Prover switch has a second function. It is provided on the heater to verify that the fan is operating. When the fan increases in negative pressure, the electrical contacts close signaling that the blower is operational and is at peak performance. The controller requires that the electrical contacts on the switch close before it will allow the burners to operate.

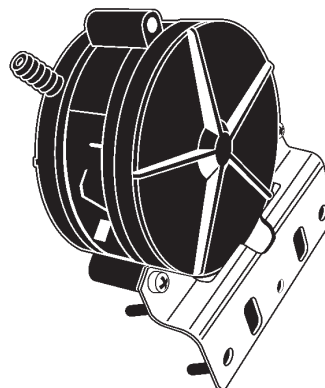

MPL 9300VO AIR PRESSURE SWITCH

STEP DOWN TRANSFORMER

The controls system utilizes a 120/24 VAC step down transformer. Most of the control system utilizes 24 VAC for operation. See wiring diagram for those components utilizing 24 VAC and 120 VAC.

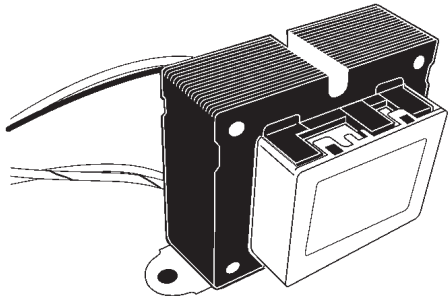

P120/24 VAC STEP DOWN TRANSFORMER

BURNER

The appliance is equipped with 8 burners mounted in a burner tray assembly. The burners are tubular in design with two rows of small slit burner ports. The natural gas burners are made of aluminized steel and the LP version is a stainless steel material.

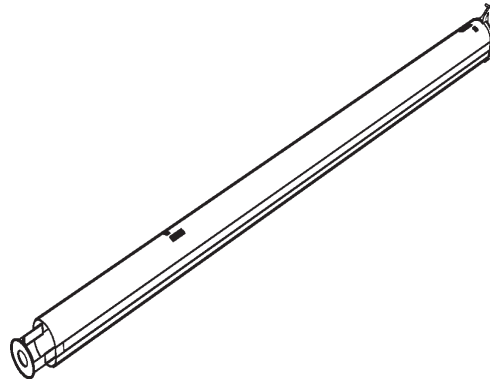

TUBULAR BURNER ASSEMBLY

BURNER TRAY ASSEMBLY

The appliance is equipped with a user friendly burner tray assembly. The assembly consists of a burner tray for mounting the burners, manifold and orifices along with the gas valve and pilot assembly. It can be easily removed by sliding the assembly in and out like a drawer due to slide mounts in the combustion chamber.

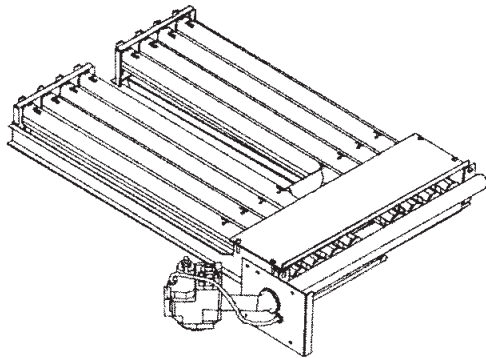

BURNER TRAY ASSEMBLY - NATURAL

BURNER ORIFICE

The burner orifice regulates the input to the main burners.

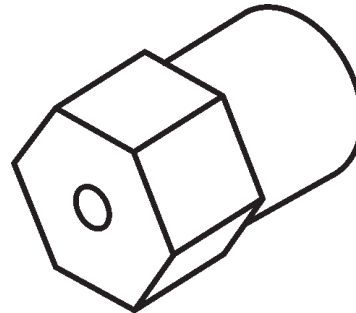

BURNER ORIFICE

BURNER TRAY

The burner tray holds the burners in place and is used to slide the entire assembly into the combustion chamber.

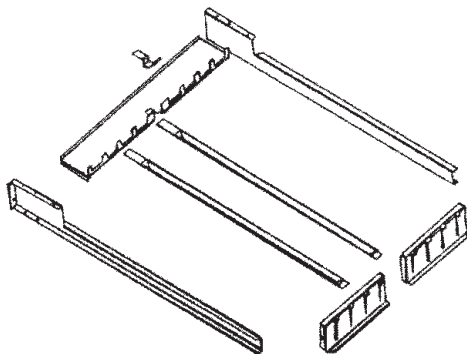

BURNER TRAY

BLOWER ASSEMBLY

The blower assembly functions by pulling in air from the outside of the unit to supply the main burners located in the combustion chamber for proper combustion. The blower pulls the air through the combustion chamber and flue tubes where the flue gases then exit the exhaust vent.

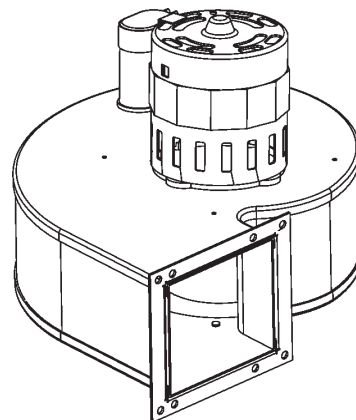

FASCO BLOWER ASSEMBLY

HIGH LIMIT SWITCH

The surface mounted high limit switch monitors the flue gases escaping through the blower assembly to ensure the temperatures do not exceed the rating for the CPVC/PVC vent pipe utilized on the venting.

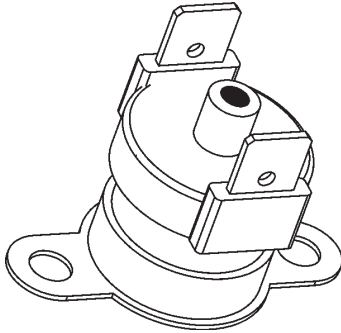
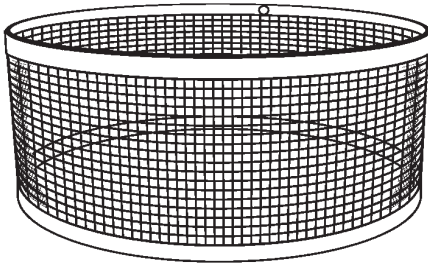

FIGURE 4
HIGH LIMIT SWITCH

SHROUD ASSEMBLY

The shroud assembly protects the top of the appliance where the blower and junction box are located.



SHROUD ASSEMBLY

TEMPERATURE AND PRESSURE RELIEF VALVE

The temperature and pressure relief valve is a mechanical valve that will open when the temperature or pressure in the tank exceeds safe limits.

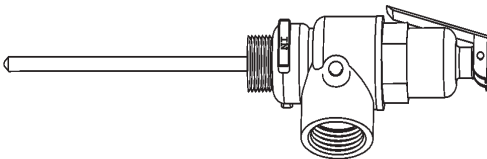

TEMPERATURE AND PRESSURE RELIEF VALVE

DRAIN VALVE

The drain valve is used to drain the unit of water for servicing or replacement.

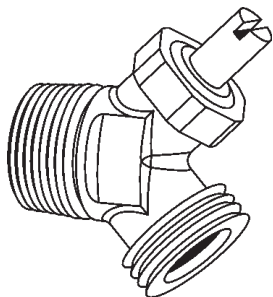

DRAIN VALVE

INSTALLATION INSTRUCTIONS

REQUIRED ABILITY

INSTALLATION OR SERVICE OF THIS WATER HEATER REQUIRES ABILITY EQUIVALENT TO THAT OF A LICENSED TRADESMAN IN THE FIELD INVOLVED. PLUMBING, AIR SUPPLY, VENTING, GAS SUPPLY AND ELECTRICAL WORK ARE REQUIRED.

⚠ WARNING

FAILURE TO FOLLOW THESE INSTRUCTIONS CAN RESULT IN SERIOUS PERSONAL INJURY OR DEATH.

HARD WATER

Where hard water conditions exist, water softening or the threshold type of water treatment is recommended. This will protect the dishwashers, coffee urns, water heaters, water piping and other equipment.

See MAINTENANCE section for details of tank clean out procedure.

LOCATING THE HEATER

When installing the heater, consideration must be given to proper location with adequate air supply and as centralized with the piping system as possible.

⚠ WARNING

THERE IS A RISK IN USING FUEL BURNING APPLIANCES SUCH AS GAS WATER HEATERS IN ROOMS, GARAGES OR OTHER AREAS WHERE GASOLINE, OTHER FLAMMABLE LIQUIDS OR ENGINE DRIVEN EQUIPMENT OR VEHICLES ARE STORED, OPERATED OR REPAIRED. FLAMMABLE VAPORS ARE HEAVY AND TRAVEL ALONG THE FLOOR AND MAY BE IGNITED BY THE HEATER'S PILOT OR MAIN BURNER FLAMES CAUSING FIRE OR EXPLOSION. SOME LOCAL CODES PERMIT OPERATION OF GAS APPLIANCES IN SUCH AREAS IF THEY ARE INSTALLED 18" OR MORE ABOVE THE FLOOR. THIS MAY REDUCE THE RISK IF LOCATION IN SUCH AN AREA CANNOT BE AVOIDED.

DO NOT INSTALL THIS WATER HEATER DIRECTLY ON A CARPETED FLOOR. A FIRE HAZARD MAY RESULT. Instead the water heater must be placed on a metal or wood panel extending beyond the full width and depth by at least 3 inches (7.6 cm) in any direction. If the heater is installed in a carpeted alcove, the entire floor shall be covered by the panel. Also, see the DRAIN REQUIREMENTS.

THE HEATER SHALL BE LOCATED OR PROTECTED SO IT IS NOT SUBJECT TO PHYSICAL DAMAGE BY A MOVING VEHICLE.

⚠ WARNING

FLAMMABLE ITEMS, PRESSURIZED CONTAINERS OR ANY OTHER POTENTIAL FIRE HAZARDOUS ARTICLES MUST NEVER BE PLACED ON OR ADJACENT TO THE HEATER. OPEN CONTAINERS OR FLAMMABLE MATERIAL SHOULD NOT BE STORED OR USED IN THE SAME ROOM WITH THE HEATER. THE HEATER MUST NOT BE LOCATED IN AN AREA WHERE IT WILL BE SUBJECT TO FREEZING. LOCATE IT NEAR A FLOOR DRAIN. THE HEATER SHOULD BE LOCATED IN AN AREA WHERE LEAKAGE FROM THE HEATER OR CONNECTIONS WILL NOT RESULT IN DAMAGE TO THE ADJACENT AREA OR TO LOWER FLOORS OF THE STRUCTURE.

WHEN SUCH LOCATIONS CANNOT BE AVOIDED, A SUITABLE DRAIN PAN SHOULD BE INSTALLED UNDER THE HEATER. Such pans should be fabricated with sides at least 2" (5 cm) deep, with length and width at least 2" (5 cm) greater than the diameter of the heater and must be piped to an adequate drain. The pan must not restrict combustion air flow.

For appliance installation locations with elevations above 2000 feet (610 m), refer to HIGH ALTITUDE INSTALLATIONS section of this manual for input reduction procedure.

LEVELING

If the unit is not level, insert the bolts which were used in crating into the legs to correct this condition.

CLEARANCES

The unit is approved for installation on combustible flooring in an alcove when the minimum clearance to combustibles is maintained per Figure 6 and the table below.

A (RIGHT SIDE)	B (LEFT SIDE)	C (BACK)	D (CEILING)
0" (0cm)	0" (0cm)	0" (0cm)	12" (30.5 cm)

A service clearance of 24" (61 cm) should be maintained from serviceable parts, such as relief valves, flue baffles, flue damper devices, thermostats, cleanout openings or drain valves.

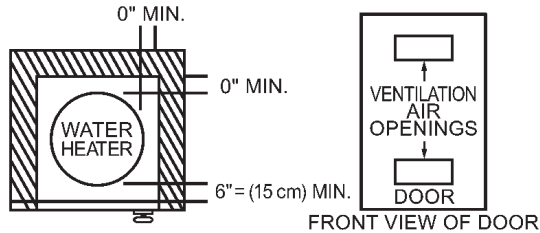

FIGURE 5

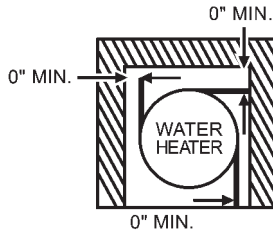

FIGURE 6

ALCOVE INSTALLATION (ACCEPTABLE)

An alcove suitable for the installation of a water heater is a restricted section of a room not separated from the room by a door or partition and which meets the minimum clearances for the water heater.

*When the ceiling height exceeds 8 feet (2.4 m), you are only allowed to consider 8 feet (2.4 m) when calculating the total volume of the enclosure.

AIR REQUIREMENTS

REFER TO THE CURRENT EDITION OF THE NATIONAL FUEL GAS CODE ANSI Z223.1/NFPA 54.



WARNING

KEEP APPLIANCE AREA CLEAR AND FREE OF COMBUSTIBLE MATERIALS, GASOLINE AND OTHER FLAMMABLES, VAPORS AND LIQUIDS.

DO NOT OBSTRUCT THE FLOW OF COMBUSTION OR VENTILATING AIR.



WARNING

FOR SAFE OPERATION PROVIDE ADEQUATE AIR FOR COMBUSTION AND VENTILATION. AN INSUFFICIENT SUPPLY OF AIR WILL CAUSE RECIRCULATION OF COMBUSTION PRODUCTS RESULTING IN AIR CONTAMINATION THAT MAY BE HAZARDOUS TO LIFE. SUCH A CONDITION OFTEN WILL RESULT IN A YELLOW, LUMINOUS BURNER FLAME, CAUSING CARBONING OR SOOTING OF THE COMBUSTION CHAMBER, BURNERS AND FLUE TUBES AND CREATES A RISK OF ASPHYXIATION.

Where an exhaust fan is supplied in the same room with a heater, sufficient openings for air must be provided in the walls. **UNDERSIZED OPENINGS WILL CAUSE AIR TO BE DRAWN INTO THE ROOM THROUGH THE CHIMNEY, CAUSING POOR COMBUSTION. SOOTING MAY RESULT IN SERIOUS DAMAGE TO THE HEATER AND RISK OF FIRE OR EXPLOSION.**

UNCONFINED SPACE

In buildings of conventional frame, brick, or stone construction, unconfined spaces may provide adequate air for combustion, ventilation and draft hood dilution.

If the unconfined space is within a building of tight construction (buildings using the following construction: weather stripping, heavy insulation, caulking, vapor barrier, etc.), air for combustion, ventilation and draft hood dilution must be obtained from outdoors. The installation instructions for confined spaces in tightly constructed buildings must be followed to ensure adequate air supply.

CONFINED SPACE

When drawing combustion and dilution air from inside a conventionally constructed building to a confined space, such a space shall be provided with two permanent openings, ONE IN OR WITHIN 12 INCHES (30.5 cm) OF THE ENCLOSURE TOP AND ONE IN OR WITHIN 12 INCHES (30.5 cm) OF THE ENCLOSURE BOTTOM. Each opening shall have a free area of at least one square inch per 1000 Btuh (2,225mm²/Kw) of the total input of all appliances in the enclosure, but not less than 100 square inches (645 square cm).

If the confined space is within a building of tight construction, air for combustion, ventilation, and draft hood dilution must be obtained from outdoors. When directly communicating with the outdoors or communicating with the outdoors through vertical ducts, two permanent openings, located in the above manner, shall be provided. Each opening shall have a free area of not less than one square inch per 4000 Btuh (8,900mm²/Kw) of the total input of all appliances in the enclosure. If horizontal ducts are used, each opening shall have a free area of not less than one square inch per 2000 Btuh (4,450mm²/Kw) of the total input of all appliances in the enclosure.

MECHANICAL EXHAUSTING OF ROOM AIR

Where an exhaust fan is installed in the same room with a heater, sufficient openings for air must be provided in the walls. **UNDERSIZED OPENINGS WILL CAUSE AIR TO BE DRAWN INTO THE ROOM THROUGH THE HEATER'S VENTING SYSTEM, CAUSING POOR COMBUSTION AND/OR SOOTING WHICH MAY RESULT IN SERIOUS DAMAGE TO THE HEATER AND RISK OF FIRE OR EXPLOSION. IT CAN ALSO CREATE A RISK OF ASPHYXIATION.**

COMBUSTION AIR AND EXHAUST



WARNING

WHEN DETERMINING THE INSTALLATION LOCATION FOR A POWER DIRECT VENT WATER HEATER, SNOW ACCUMULATION AND DRIFTING SHOULD BE CONSIDERED IN AREAS WHERE APPLICABLE.

VENTING CLEARANCES

VENTING THROUGH AN OUTSIDE WALL-CLEARANCES

- 1" (2.5 cm) clearance for 4" or 6" PVC or CPVC piping from combustible surfaces for **outlet** piping.
- 0" clearance for 4" or 6" PVC or CPVC piping from combustible surfaces for **inlet** piping.
- 18" (46 cm) minimum in all directions from any obstruction, such as a wall, that may interfere.
- 18" (46 cm) minimum from the ground and 9" from ceiling overhangs. See Figure 7.
- The Power Direct Vent outlet terminal shall terminate a least 36" (91 cm) above any forced air inlet located within 10 feet. See Figure 8.
- The Power Direct Vent outlet terminal shall terminate at least 36" (91 cm) below, 36" (91 cm) horizontally from or 18" (46 cm) above any door, window or gravity air inlet into the building. See Figure 8.
- 18" (46 cm) minimum from other natural draft (gravity) direct vent, power vent or power direct vent appliance inlet and/or outlet vent(s) when directly above or 135° to either side of center line. See Figure 9.
- 36" (91 cm) minimum from any appliance inlet and / or outlet vents when directly below or 45° to either side of center line. See Figure 9.
- Vent termination must not be within 4 feet of any items such as gas meters, gas valves or other gas regulating equipment.
- The venting system must be installed in a manner which allows inspection of the installation of the venting pipes and joints as well as periodic inspection after installation as required by ANSI Standards.

WARNING

THE LOCATION SELECTED MUST PROVIDE CLEARANCES FOR SERVICING AND PROPER OPERATION OF THE WATER HEATER.

WARNING

VENT TERMINATION MUST NOT BE WITHIN 4 FEET OF ANY ITEMS SUCH AS GAS METERS, GAS VALVES OR OTHER GAS REGULATING EQUIPMENT.

WARNING

FAILURE TO HAVE REQUIRED CLEARANCES BETWEEN WATER HEATER AND COMBUSTIBLE MATERIAL WILL RESULT IN A FIRE HAZARD.

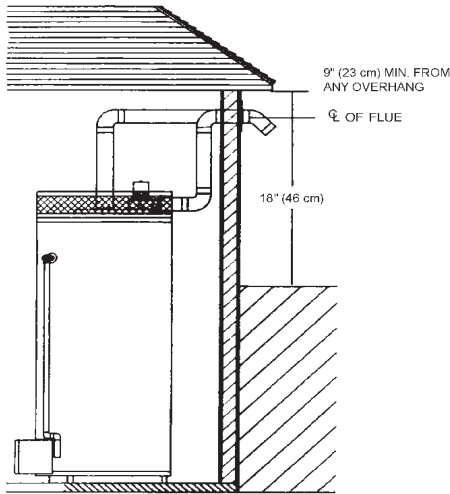

FIGURE 7

FACTS TO CONSIDER ABOUT THE LOCATION

VENTING THROUGH ROOF-CLEARANCES

- 1" (2.5 cm) clearance for 4" or 6" PVC or CPVC piping from combustible surfaces for **outlet** piping.
- 0" clearance for 4" or 6" PVC or CPVC piping from combustible surfaces for **inlet** piping.
- The Power Direct Vent inlet and outlet terminals shall terminate at least 18" (46 cm) above the roof surface. See Figure 10.
- The venting system must be installed in a manner which allows inspection of the installation of the venting pipes and joints as well as periodic inspection after installation as required by ANSI Standards.

"A" - 10-1/2" (27 cm) MIN. (4" VENT)
12" (30.5 cm) MIN. (6" VENT)
24" (61 cm) MAX.

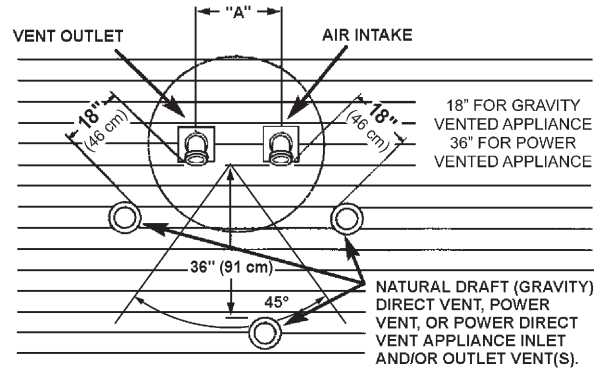

FIGURE 9

WIRE FENCE

When the water heater outlet terminal is low enough to be touched accidentally, or is accessible to small children, a wire mesh chain link fence (as shown in Figure 9) may be used. Care should be taken to maintain adequate ventilation around the outlet terminal. If a chain link fence is installed, it must not be used as a storage area for items that may block proper ventilation.

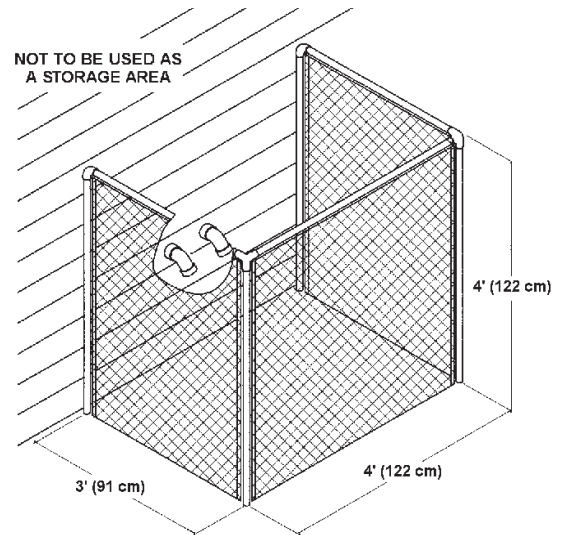

FIGURE 9

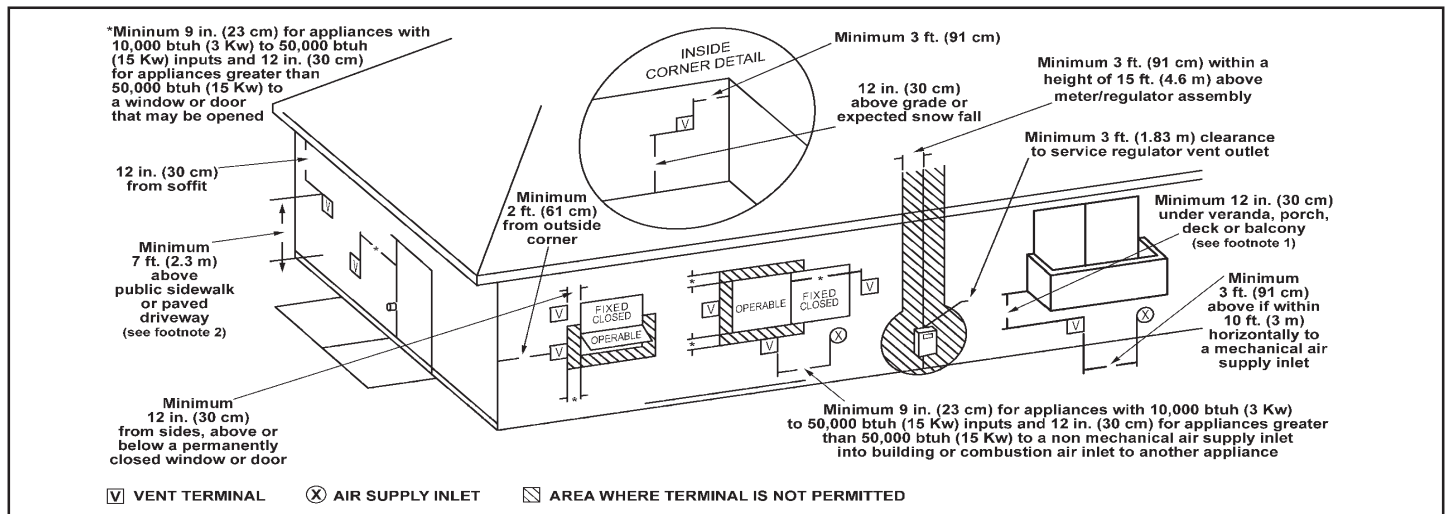

FIGURE 8 - DIRECT VENT TERMINAL CLEARANCES - US INSTALLATION

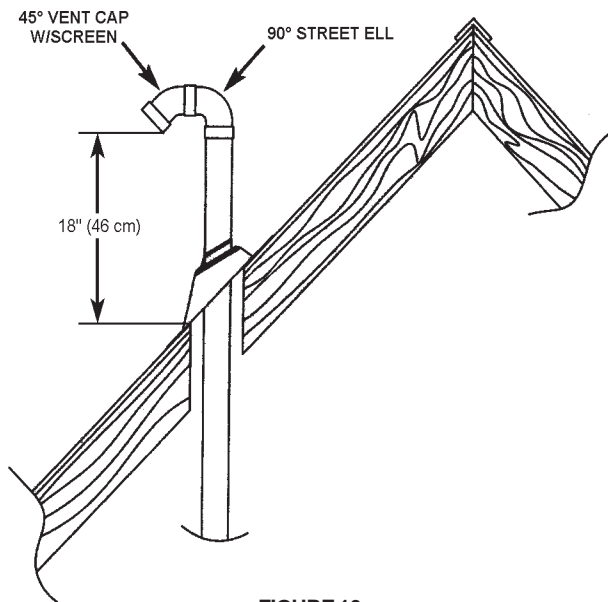

FIGURE 10

WATER PIPING

⚠ WARNING

HOTTER WATER CAN SCALD: WATER HEATERS ARE INTENDED TO PRODUCE HOT WATER. WATER HEATED TO A TEMPERATURE WHICH WILL SATISFY CLOTHES WASHING, DISH WASHING, AND OTHER SANITIZING NEEDS CAN SCALD AND PERMANENTLY INJURE YOU UPON CONTACT. SOME PEOPLE ARE MORE LIKELY TO BE PERMANENTLY INJURED BY HOT WATER THAN OTHERS. THESE INCLUDE THE ELDERLY, CHILDREN, THE INFIRM, OR PHYSICALLY/MENTALLY HANDICAPPED. IF ANYONE USING HOT WATER IN YOUR HOME FITS INTO ONE OF THESE GROUPS OR IF THERE IS A LOCAL CODE OR STATE LAW REQUIRING A CERTAIN TEMPERATURE WATER AT THE HOT WATER TAP, THEN YOU MUST TAKE SPECIAL PRECAUTIONS. IN ADDITION TO USING THE LOWEST POSSIBLE TEMPERATURE SETTING THAT SATISFIES YOUR HOT WATER NEEDS, A MEANS SUCH AS A MIXING VALVE, SHOULD BE USED AT THE HOT WATER TAPS USED BY THESE PEOPLE OR AT THE WATER HEATER. MIXING VALVES ARE AVAILABLE AT PLUMBING SUPPLY OR HARDWARE STORES. FOLLOW MANUFACTURERS INSTRUCTIONS FOR INSTALLATION OF THE VALVES. BEFORE CHANGING THE FACTORY SETTING ON THE THERMOSTAT, READ THE "TEMPERATURE REGULATION" SECTION IN THIS MANUAL.

This water heater shall not be connected to any heating systems or component(s) used with a non-potable water heating appliance.

If a water heater is installed in a closed water supply system, such as one having a back-flow preventer, check valve, water meter with check valve, etc... in the cold water supply, means shall be provided to control thermal expansion. Contact the water supplier or plumbing contractor on how to control this situation.

NOTE: To protect against untimely corrosion of hot and cold water fittings, it is strongly recommended that dielectric unions or couplings be installed on this water heater when connected to copper pipe.

NOTE: If using copper tubing, solder tubing to an adapter before attaching the adapter to the cold water inlet connection. Do not solder the cold water supply line directly to the cold water inlet. It will harm the dip tube and damage the tank.

⚠ WARNING

IF A WATER HEATER IS INSTALLED IN CONJUNCTION WITH A SEPARATE STORAGE VESSEL, THE STORAGE VESSEL MUST ALSO BE EQUIPPED WITH A TEMPERATURE-PRESSURE RELIEF VALVE

COMPLYING WITH THE STANDARD FOR RELIEF VALVES AND HOT WATER SUPPLY SYSTEMS, ANSI Z21.22. THE HOURLY RATED TEMPERATURE STEAM BTU DISCHARGE CAPACITY OF THE TEMPERATURE-PRESSURE RELIEF VALVE(S) SHALL NOT BE LESS THAN THE COMBINED BTU INPUT TO THE WATER HEATER(S) SUPPLYING WATER TO THE STORAGE VESSEL(S).

THERMOMETERS (Not Supplied)

Thermometers should be obtained and field installed as shown in the installation diagrams.

Thermometers are installed in the system as a means of detecting the temperature of the water in the appliance.

TEMPERATURE-PRESSURE RELIEF VALVE

This water heater is equipped with a combination temperature-pressure relief valve that complies with the standard for relief valves and automatic gas shutoff devices for hot water supply system, ANSI Z21.22. **FOR SAFE OPERATION OF THE WATER HEATER, THE RELIEF VALVE(S) MUST NOT BE REMOVED OR PLUGGED.**

ASME ratings cover pressure relief capacities. A.G.A. ratings cover release rate with temperature actuation.

In addition to the appliance relief valve, each remote storage tank which may be used in conjunction with this appliance shall also be installed with a properly sized, rated and approved combination temperature (ANSI) and pressure (ASME) relief valve(s).

⚠ WARNING

THE PURPOSE OF RELIEF VALVE IS TO AVOID EXCESSIVE PRESSURE OR TEMPERATURE INTO THE STEAM RANGE, WHICH MAY CAUSE SCALDING AT FIXTURES, TANK EXPLOSION, SYSTEM OR HEATER DAMAGE. NO VALVE IS TO BE PLACED BETWEEN THE RELIEF VALVE AND TANK.

Your local code authority may have other specific relief valve requirements.

A DRAIN LINE MUST BE CONNECTED TO THE RELIEF VALVE TO DIRECT DISCHARGE TO A SAFE LOCATION TO AVOID SCALDING OR WATER DAMAGE. THIS LINE MUST NOT BE REDUCED FROM THE SIZE OF THE VALVE OUTLET AND MUST NOT CONTAIN VALVES OR RESTRICTIONS NOR SHOULD IT BE LOCATED IN FREEZING AREAS. DO NOT THREAD OR CAP THE END OF THIS LINE. RESTRICTED OR BLOCKED DISCHARGE WILL DEFEAT THE PURPOSE OF THE VALVE AND IS UNSAFE. DISCHARGE LINE SHALL BE INSTALLED TO ALLOW COMPLETE DRAINAGE OF BOTH THE VALVE AND LINE.

See **SERVICE INFORMATION** section for procedure and precautions.

⚠ WARNING

THE TEMPERATURE-PRESSURE RELIEF VALVE MUST BE MANUALLY OPERATED AT LEAST ONCE A YEAR. CAUTION SHOULD BE TAKEN TO ENSURE THAT (1) NO ONE IS IN FRONT OF OR AROUND THE OUTLET OF THE TEMPERATURE-PRESSURE RELIEF VALVE DISCHARGE LINE, AND (2) THE WATER MANUALLY DISCHARGED WILL NOT CAUSE ANY BODILY INJURY OR PROPERTY DAMAGE BECAUSE THE WATER MAY BE EXTREMELY HOT. IF AFTER MANUALLY OPERATING THE VALVE, IT FAILS TO COMPLETELY RESET AND CONTINUES TO RELEASE WATER, IMMEDIATELY CLOSE THE COLD WATER INLET TO THE WATER HEATER, FOLLOW THE DRAINING INSTRUCTIONS, AND REPLACE THE TEMPERATURE -PRESSURE RELIEF VALVE WITH A NEW ONE.

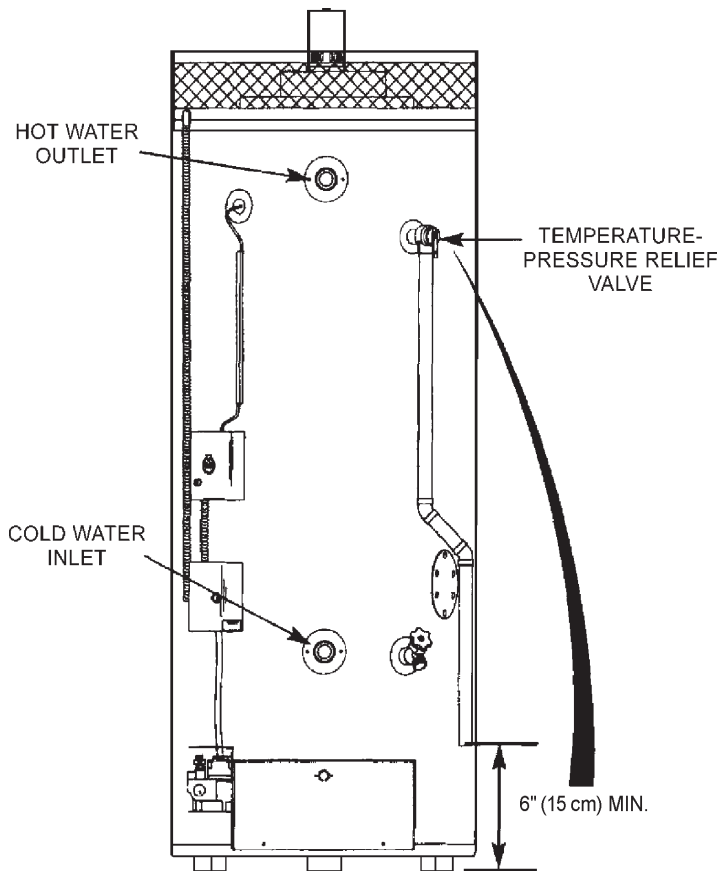

FILLING THE WATER HEATER

CAUTION

NEVER USE THIS WATER HEATER UNLESS IT IS COMPLETELY FILLED WITH WATER. TO PREVENT DAMAGE TO THE TANK, THE TANK MUST BE FILLED WITH WATER. WATER MUST FLOW FROM THE HOT WATER FAUCET BEFORE TURNING "ON" GAS TO THE WATER HEATER.

To fill the water heater with water:

1. Close the water heater drain valve by turning the handle to the right (clockwise). The drain valve is on the lower front of the water heater.
2. Open the cold water supply valve to water heater. **NOTE: The cold water supply valve must be left open when the water heater is in use.**
3. To insure complete filling of the tank, allow air to exit by opening the nearest hot water faucet. Allow water to run until a constant flow is obtained. This will let air out of the water heater and the piping.
4. Check all new water piping for leaks. Repair as needed.

WIRING

You must provide all wiring of the proper size outside of the water heater. You must obey local codes and electric company requirements when you install this water heater.

If you are not familiar with electric codes and practices, or if you have any doubt in your ability to connect the wiring to this water heater, contact a local electrical contractor and/or the local electric utility.

WARNING

WATER HEATERS EQUIPPED FOR ONE TYPE VOLTAGE ONLY: THIS WATER HEATER IS EQUIPPED FOR 110/120 VOLTS ONLY. DO NOT USE THIS WATER HEATER WITH ANY VOLTAGE OTHER THAN THE ONE SHOWN ABOVE. FAILURE TO USE THE CORRECT VOLTAGE CAN CAUSE PROBLEMS WHICH CAN RESULT IN DEATH, SERIOUS BODILY INJURY OR PROPERTY DAMAGE. IF YOU HAVE ANY QUESTIONS OR DOUBTS CONSULT YOUR ELECTRIC COMPANY.

CAUTION

IF WIRING FROM THE FUSE BOX OR CIRCUIT BREAKER BOX WAS ALUMINUM FOR THE OLD WATER HEATER, REPLACE IT WITH COPPER WIRE. IF YOU WISH TO REUSE THE EXISTING ALUMINUM WIRE, HAVE THE CONNECTION AT THE WATER HEATER MADE BY A LOCAL ELECTRICAL CONTRACTOR AND/OR THE LOCAL ELECTRIC UTILITY.

FIELD INSTALLED WIRING

1. Provide a way to easily shut off the electric power when working on the water heater. This could be with a circuit breaker or fuse block in the entrance box or a separate disconnect switch.
2. Install and connect a circuit directly from the main fuse or circuit breaker box. This circuit must be per applicable codes and have its own fuse or circuit breaker.
3. Standard 1/2" conduit openings have been made in the water heater junction box for side or bottom conduit connection.
4. Use wire nuts and connect the power supply wiring to the wires inside the water heater's junction box. **MINIMUM LINE VOLTAGE WIRE NO. 14 AWG.**

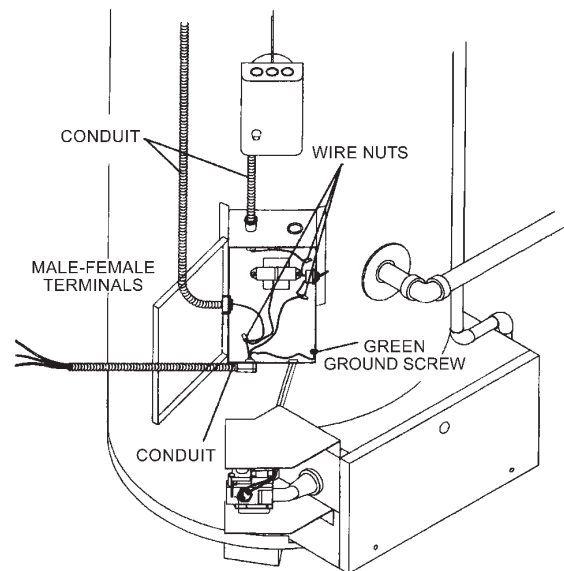

5. **The water heater must be electrically "grounded" by the installer. The unit will not operate unless it is properly grounded.** A green ground screw has been provided on the water heater's junction box. Connect ground wire to this location. For complete grounding details and all allowable exceptions, refer to local codes or in the absence of local codes, with the National Electrical Code, ANSI/NFPA 70 (current edition).
6. Close the wiring junction box cover.

WIRING DIAGRAM FOR ROBERTSHAW CONTROL SYSTEM - NATURAL GAS ONLY

NOTE: If any of the original wire as supplied with the water heater must be replaced, it must be replaced with 105°C thermoplastic AWM wire or its equivalent.



LABEL ALL WIRES PRIOR TO DISCONNECTION WHEN SERVICING CONTROLS. WIRING ERRORS CAN CAUSE IMPROPER AND DANGEROUS OPERATION. VERIFY PROPER OPERATION AFTER SERVICING.

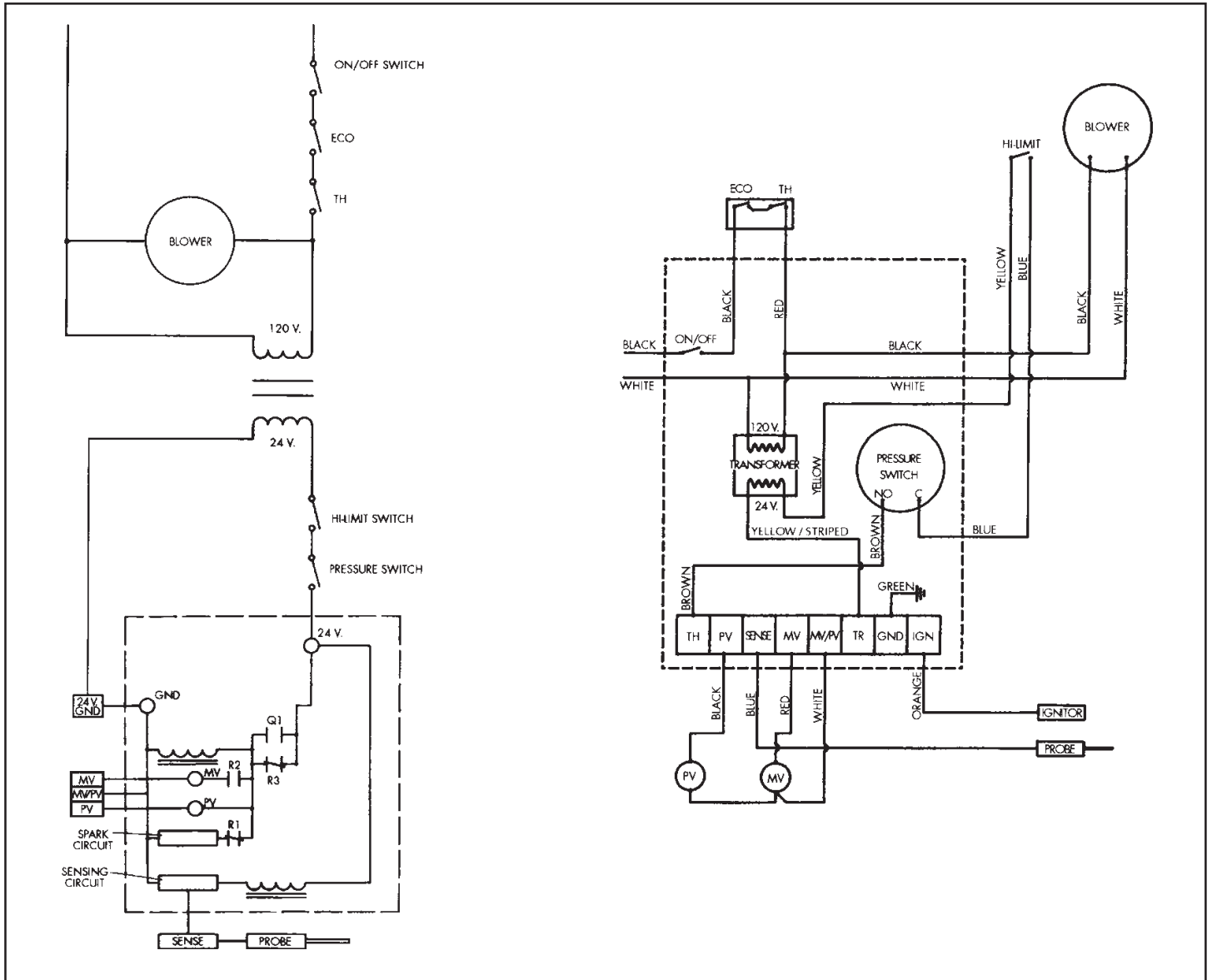

MINIMUM LINE VOLTAGE WIRE NO. 14 AWG

VENTING

⚠ WARNING

TO INSURE PROPER VENTING OF THIS GAS-FIRED WATER HEATER, THE CORRECT VENT PIPE DIAMETER MUST BE UTILIZED. ANY ADDITIONS OF OTHER GAS APPLIANCES ON VENT WITH THIS WATER HEATER ARE PROHIBITED AS THEY WILL ADVERSELY AFFECT THE OPERATION OF THE WATER HEATER.

⚠ WARNING

OBSTRUCTED OR DETERIORATED VENT SYSTEMS MAY PRESENT SERIOUS HEALTH RISK OR ASPHYXIATION.

⚠ WARNING

THE VENT PIPE FROM THE WATER HEATER MUST BE 4" DIAMETER (16" OR 41 CM MIN. AND UP TO 45' OR 13.7 M WITH ONE 90° ELBOW) OR 6" DIAMETER (45' OR 13.7 M MIN. AND UP TO 110' OR 33.5 M WITH ONE 90° ELBOW) AND MUST SLOPE UPWARD 1/8" (3 MM) PER FIVE LINEAR FEET (1.5 M) FOR ANY HORIZONTAL RUN.

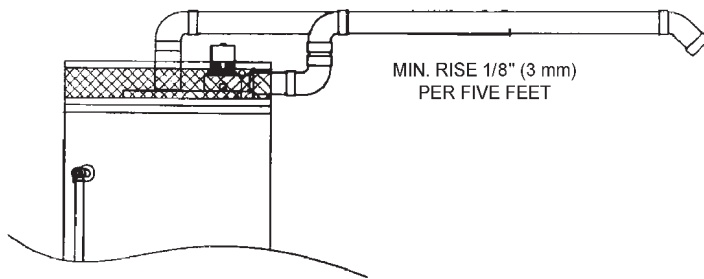

All vent gases must be completely vented to the outdoors of the structure (dwelling).

⚠ WARNING

FAILURE TO HAVE REQUIRED CLEARANCES BETWEEN WATER HEATER AND COMBUSTIBLE MATERIAL WILL RESULT IN A FIRE HAZARD.

⚠ WARNING

BE SURE VENT PIPE IS PROPERLY CONNECTED TO PREVENT ESCAPE OF DANGEROUS FLUE GASES WHICH COULD CAUSE DEADLY ASPHYXIATION.

⚠ WARNING

CHEMICAL VAPOR CORROSION OF THE FLUE AND VENT SYSTEM MAY OCCUR IF AIR FOR COMBUSTION CONTAINS CERTAIN CHEMICAL VAPORS SPRAY CAN PROPELLANTS, CLEANING SOLVENTS, REFRIGERATOR AND AIR CONDITIONER REFRIGERANTS, SWIMMING POOL CHEMICALS, CALCIUM AND SODIUM CHLORIDE, WAXES, BLEACH AND PROCESS CHEMICALS ARE TYPICAL COMPOUNDS WHICH ARE POTENTIALLY CORROSIVE.

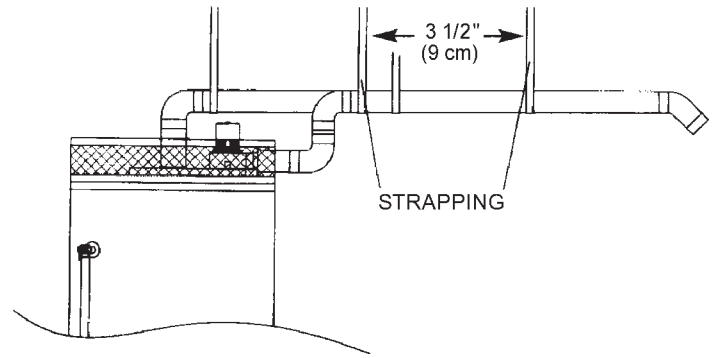

Horizontal runs must be securely supported at 3 1/2 foot intervals and vertical runs supported at 5 foot intervals.

VENTING THROUGH AN OUTSIDE WALL

Items supplied in the carton:

1. One 4" inlet PVC Schedule 40 - 45° vent cap with screen.
2. One 4" outlet CPVC Schedule 80 - 45° vent cap with screen.
3. Two 6" to 4" galvanized steel reducers.
4. Two wire screens to fit one each 6" PVC or CPVC 45° vent caps (the 6" PVC or CPVC vent caps must be supplied locally).
5. One 4" long CPVC Schedule 40-6" diameter pipe section.
6. Four 4" and 6" wall collars.

All other PVC Schedule 40 or CPVC Schedule 40 or 80 piping and fittings must be obtained locally.

TYPICAL INSTALLATION - UP TO 45' (13.7 M)

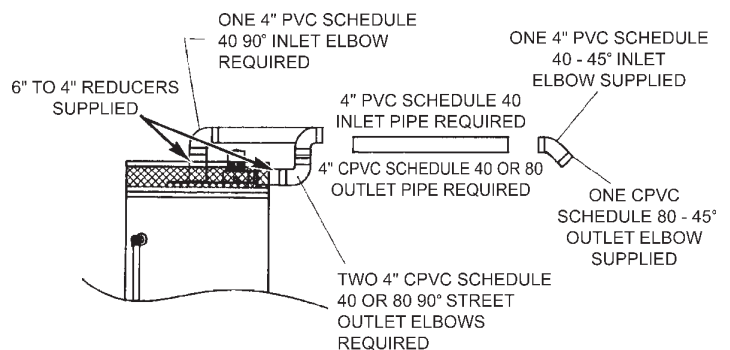

Follow illustration above if making an immediate horizontal run of vent off the blower fittings on top of the water heater.

For vent installations up to 110' (33.5 m), see page 16.

1. The water heater requires its own (separate) venting system.
2. **Only** 4" CPVC Schedule 40 piping and fittings are acceptable materials for the first ten feet of the outlet vent system.
3. 4" PVC Schedule 40 or CPVC Schedule 40 or 80 piping and fittings are acceptable materials for the **inlet** vent system and for the **outlet** vent system after the first 10' (3 m). See vent length chart on page 16.

VENTING (CONT'D)

TYPICAL INSTALLATION - UP TO 110' (33.5 m)

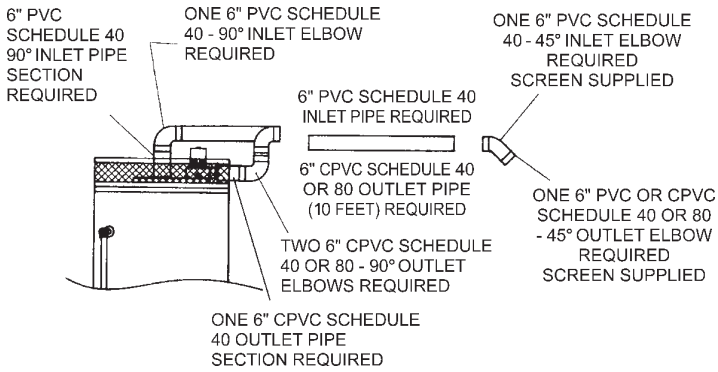

Follow illustration above if making an immediate horizontal run of vent off the blower fittings on top of the water heater.

1. The water heater requires its own (separate) venting system.
2. **Only** 6" CPVC Schedule 40 or 80 piping and fittings are acceptable materials for the first ten feet of the **outlet** vent system.
3. 6" PVC Schedule 40 or CPVC Schedule 40 or 80 piping and fittings are acceptable materials for the **inlet** vent system and for the **outlet** vent system after the first ten feet. See vent length chart on this page.

VENTING SYSTEM EXAMPLE INSTALLATIONS FOR ALL MODELS

The vent piping cannot under any circumstances be run downhill.

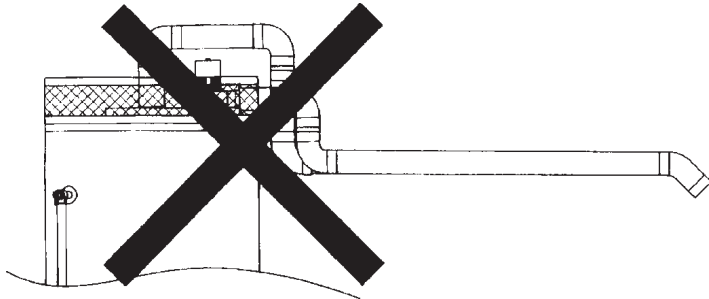

THE VENT PIPING CAN BE INSTALLED AS FOLLOWS:

1. Horizontal runs require a minimum 1/8" (3 mm) rise per five feet.

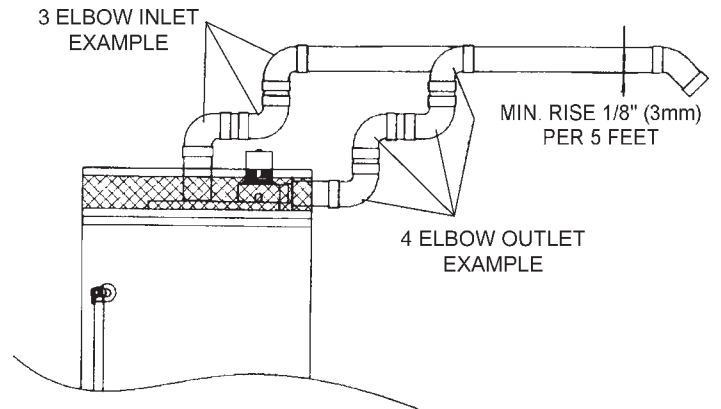
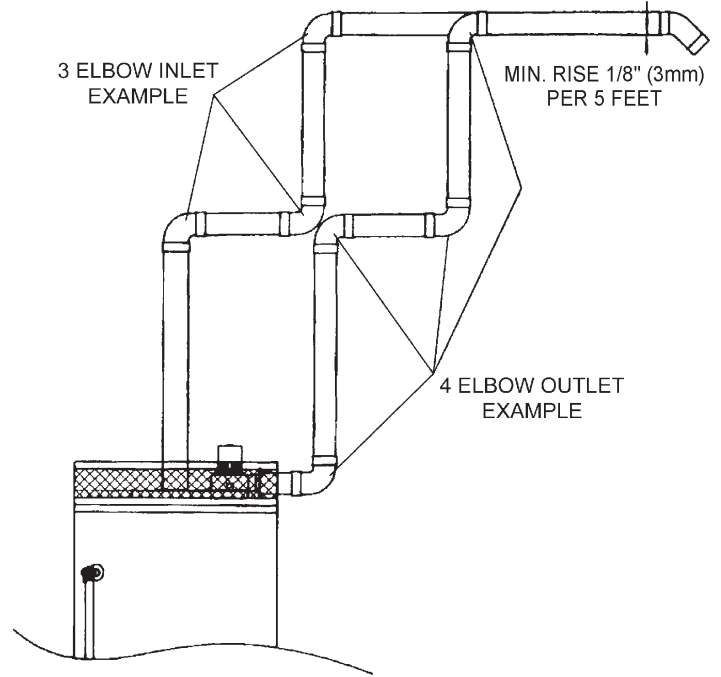
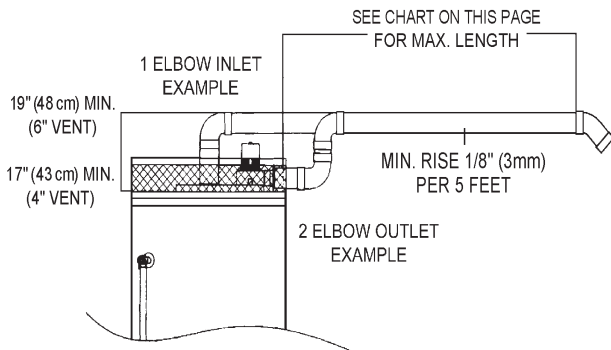

2. The total vertical and horizontal run cannot exceed the maximum length with number of 90° elbows as specified in the tables below. If more elbows are required, the venting distance must be reduced 5' (1.5 m) for every 90° elbow:

MODEL 100-400	MODEL 100-400	NUMBER OF 90° DEG. ELBOWS*
4" DIA. VENT MAX. LENGTH	6" DIA. VENT MAX. LENGTH	
45' (13.7 m)	110' (33.5 m)	1
40' (12 m)	105' (32 m)	2
35' (11 m)	100' (30.5 m)	3
30' (9 m)	95' (29 m)	4
25' (7.6 m)	90' (27.4 m)	5
20' (6 m)	85' (26 m)	6
15' (4.6 m)	80' (24.4 m)	7
10' (3 m)	75' (23 m)	8

*NOTE: Two 45° elbows are equivalent to one 90° elbow. One 90° elbow equals 5' (1.5 m) equivalent vent length.

- Minimum vent length is 18" (46 cm) when 4" pipe is used and 45' (13.7 m) when 6" pipe is used.

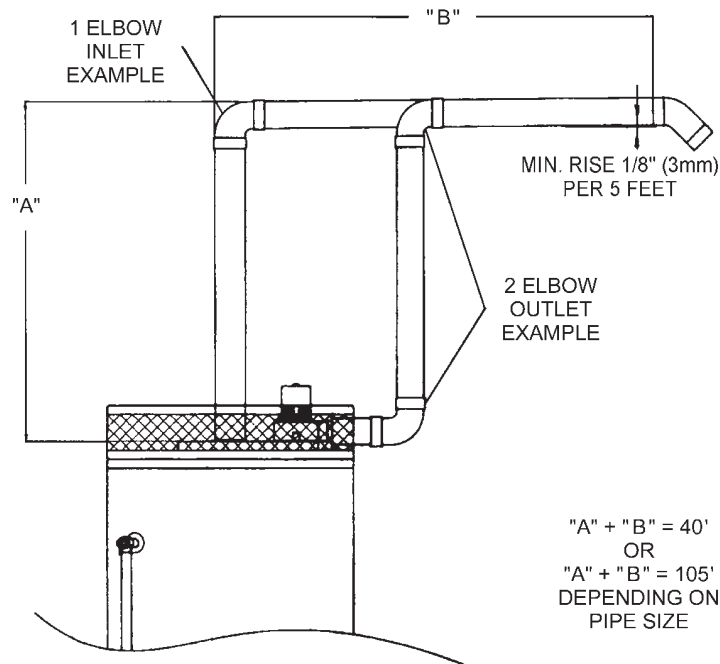

CEMENTING PVC OR CPVC PIPE AND FITTINGS

Read and observe all safety information printed on primer, cleaner, and cement containers.

⚠ DANGER

PRIMER, CLEANER, AND CEMENTS ARE EXTREMELY FLAMMABLE. THEY ARE HARMFUL OR FATAL IF SWALLOWED. THE VAPORS ARE HARMFUL. THEY MAY IRRITATE EYES AND SKIN AND CAN BE ABSORBED THROUGH THE SKIN.

⚠ CAUTION

ALWAYS STORE PRIMERS, CLEANER, AND CEMENTS IN COOL, DRY, WELL VENTILATED PLACES. DO NOT STORE THEM NEAR HEAT, SPARKS, OR FLAMES. KEEP CONTAINERS CLOSED. USE THEM IN WELL VENTILATED AREAS. WEAR IMPERVIOUS CLOTHING WHILE HANDLING. DO NOT SMOKE, EAT, OR DRINK WHILE HANDLING. WASH THOROUGHLY AFTER HANDLING AND BEFORE EATING. WEAR EYE PROTECTION WHEN HANDLING. IF SWALLOWED, DRINK WATER, DO NOT INDUCE VOMITING, AND CALL A PHYSICIAN OR POISON CONTROL CENTER IMMEDIATELY. IF INHALED, GET FRESH AIR AND SEEK MEDICAL ATTENTION IF ILL FEELINGS PERSIST. IN CASE OF EYE AND SKIN CONTACT, IMMEDIATELY FLUSH WITH PLENTY OF WATER FOR 15 MINUTES AND SEEK MEDICAL ATTENTION IF IRRITATION PERSISTS. KEEP OUT OF REACH OF CHILDREN.

All primers, cleaners, and cements must meet all local codes and applicable standards of the American Society For Testing Materials Standards.

Before using primers, cleaners, and cements, stir or shake, making sure contents are liquid. Do not use if found to be lumpy or jellylike.

- Cut pipe ends squarely removing all burrs and dirt.
- Dry fit pipe and fittings to be connected for proper fit.
- Clean pipe and fitting with a primer/cleaner.
- Apply a thin coat of cement to fitting, avoiding puddling inside.
- Apply a liberal coat of cement to pipe leaving no voids.

- QUICKLY assemble parts while cement is fluid! If you wait too long, recoat pipes.
- Push pipe completely into socket of fitting, turning as it goes until it bottoms.
- Hold pipe and fitting together for 30 seconds. Then carefully clean off excess with a cloth. Allow connections a sufficient time to cure before disturbing.
- Remember that vent pipes must be adequately and securely supported.

APPROXIMATE SETTING TIME FOR 2 1/2" TO 6" PIPE JOINTS

	MOVEMENT OF JOINT	COMPLETE SET
90°F to 150°F	3/4 hr.	8 hrs.
50°F to 90°F	1 hr.	15 hrs.
0°F to 50°F	1 1/3 hr.	18 hrs.

VENT PIPE SEPARATION

The inlet and outlet vent pipes must be separated by a minimum distance of 10 1/2" (27 cm) with 4" vent, 12" (30.5 cm) with 6" vent and up to 24" maximum.

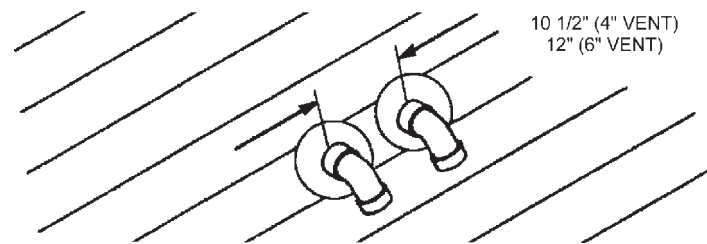

NOTE: Inlet and outlet vent pipes from multiple power direct vent water heaters must be separated from adjacent heater vent pipes by a minimum of 10 1/2" (27 cm) with 4" vent or 12" (30.5 cm) with 6" vent.

CUTTING OPENING THROUGH AN OUTSIDE WALL AND COLLAR INSTALLATION

After reading the manual and you have determined the location of the opening in the wall, (using the drawing below), cut one 4 1/2" (11 cm) diameter (for 4" vent pipe) or 6 1/2" (16.5 cm) diameter (for 6" vent pipe) hole for the inlet vent piping and one 6 1/2" (16.5 cm) diameter (for 4" vent pipe) or 8 1/2" (21.6 cm) diameter (for 6" vent pipe) hole for the outlet vent piping through an exterior wall.

NOTE: When determining location of the openings in the outside wall allow for the 1/8" (3 mm) rise per 5' (1.5 m) that has taken place in the horizontal run.

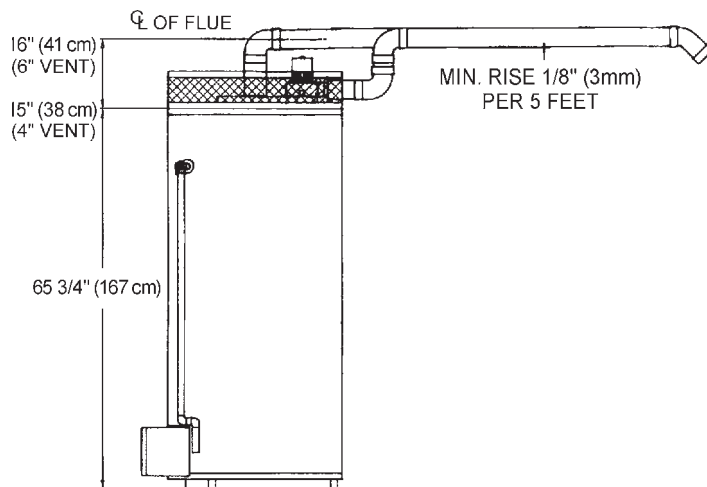

The 4" or 6" PVC Schedule 40 or CPVC Schedule 40 or 80 vent pipes can be run from the water heater through the wall or from the wall to the water heater, whichever is most convenient. The vent pipes must extend a minimum of 1 1/2" (3.8 cm) through the exterior wall. Extending the vent caps as far as possible from the surface of the exterior wall will help minimize discoloration of the wall. Note that the inside flue mounting adaptors must be slipped over the vent piping before locating the pipe through the wall. Before securing the inside and outside collars to the wall, use a silicone sealer between pipe and opening to insure a water and air tight seal.

INSTALLATION SHOWING USE OF PVC OR CPVC PIPE FOR INLET VENT PIPING:

Inlet piping through any type wall.

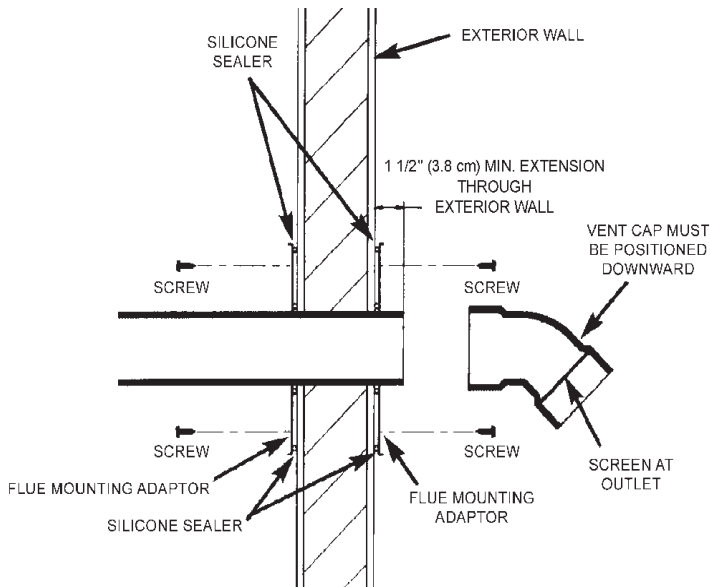

INSTALLATION SHOWING USE OF PVC OR CPVC PIPE FOR OUTLET VENT PIPING:

Outlet vent piping showing 1" (2.5 cm) clearance through a wall of combustible construction.

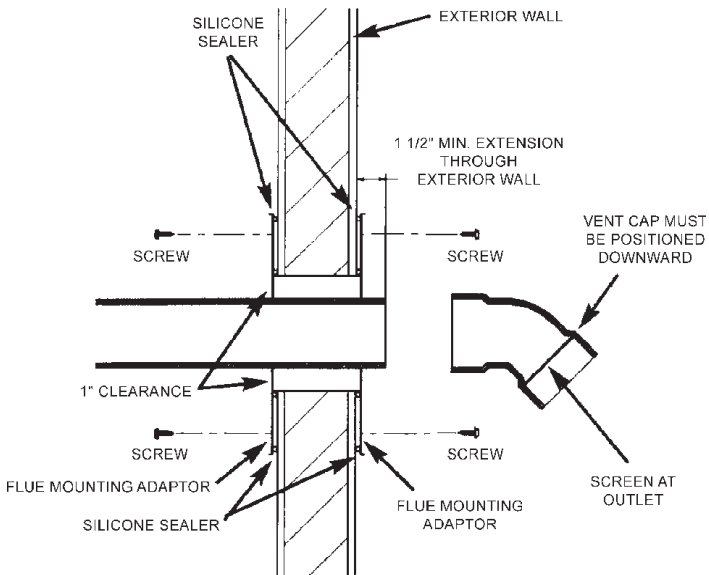

CONNECTING VENT TO BLOWER - 4" VENT PIPING

1. If making an immediate horizontal run of vent off the blower, the 6" (15 cm) to 4" galvanized steel reducer and a PVC Schedule 40 street elbow are required for the inlet pipe, and the 6" to 4" reducer and two CPVC Schedule 40 or 80 street elbows are required for the outlet vent. Place the elbows in the required direction on the reducers, and using 3 sheet metal screws each, attach the reducers to the blower inlet and outlet collars and then attach the elbows to the reducers.

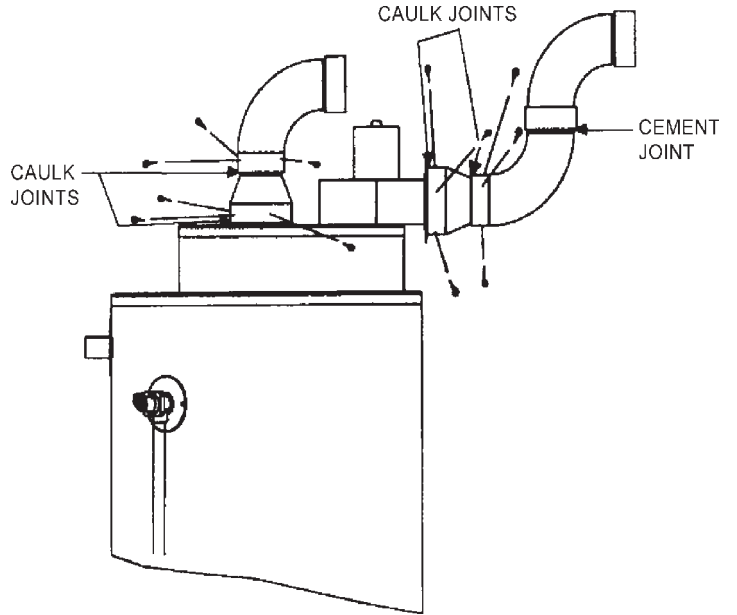

2. If there is to be a vertical run of vent from the blower, the 6" to 4" galvanized steel reducer must be attached to the venting hood collar and then the PVC inlet pipe can be attached to the reducer using 3 sheet metal screws for each connection. A 6" to 4" reducer must be attached to the blower outlet collar. Next, an outlet CPVC Schedule 40 or 80 street elbow is attached to the reducer using 3 sheet metal screws for each connection. The CPVC Schedule 40 or 80 outlet piping (for the first 10' or 3.05 cm) is then cemented to the street elbow.

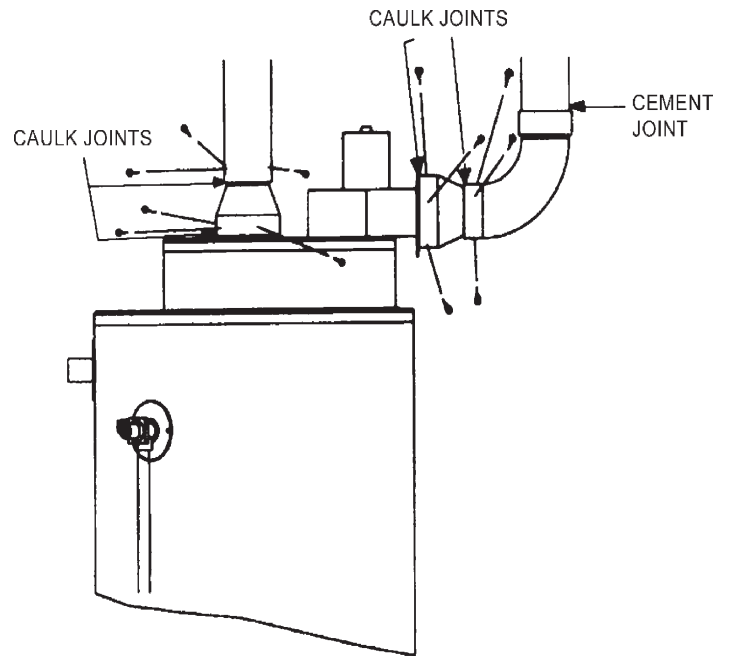

CONNECTING VENT TO BLOWER - 6" VENT PIPING

1. If making an immediate horizontal run of vent off the blower, a 7 1/4" (18.4cm) min. long PVC Schedule 40 pipe section and an elbow are required for the inlet pipe. A 4" min. long CPVC Schedule 40 pipe section (supplied), one CPVC Schedule 40 or 80 regular elbow and one CPVC Schedule 40 or 80 street elbow are required for the outlet vent.

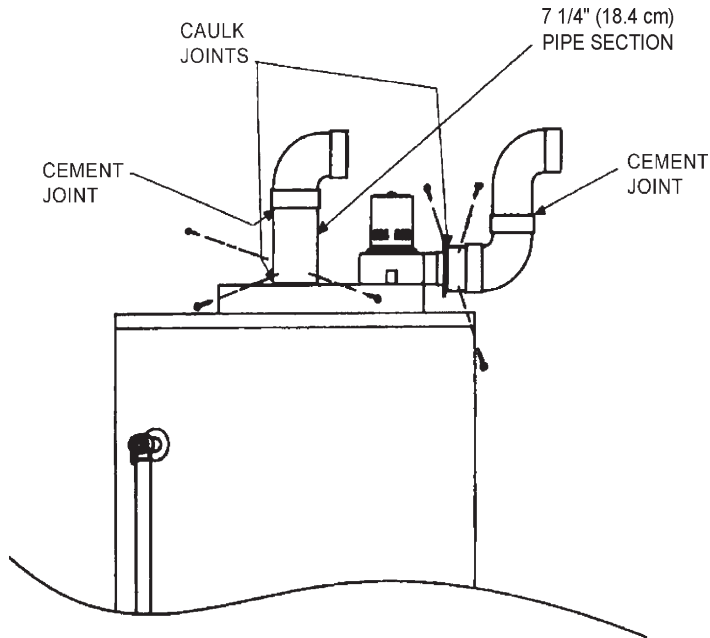

2. If there is to be a vertical run of vent from the blower, the PVC Schedule 40 inlet pipe must be attached to the venting hood collar. A 4" min. long CPVC Schedule 40 pipe section (supplied) must be attached to the blower outlet collar using three sheet metal screws. A CPVC Schedule 40 or 80 elbow is then cemented on to the end of the 4" pipe section. CPVC Schedule 40 or 80 pipe (for the first ten feet) is then cemented to the upturned elbow.

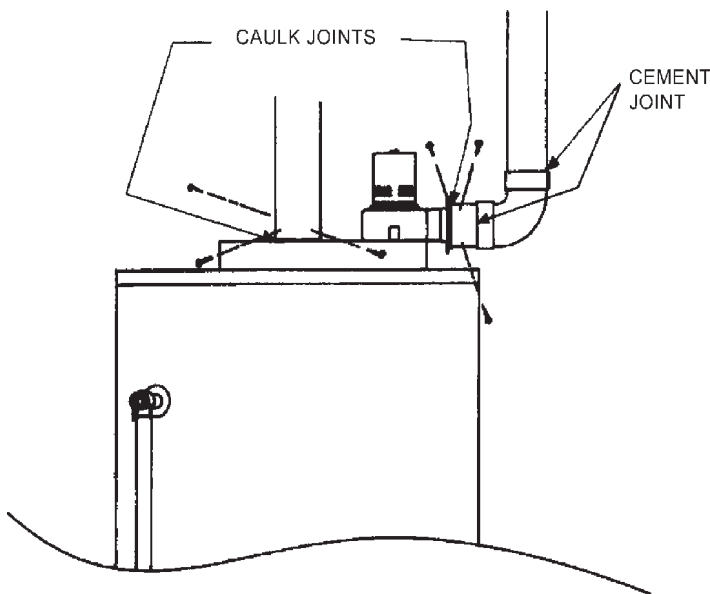

VENTING THROUGH A ROOF

Items supplied in the carton:

1. One 4" inlet PVC Schedule 40 - 45° vent cap with screen.
2. One 4" outlet CPVC Schedule 80 - 45° vent cap with screen.
3. Two 6" to 4" galvanized steel reducers.
4. Two wire screens to fit one each 6" PVC or CPVC 45° vent caps (the 6" PVC or CPVC vent caps must be supplied locally).
5. One 4" long CPVC Schedule 40 6" diameter pipe section.
6. Four 4" and four 6" wall collars.

All other PVC Schedule 40 or CPVC Schedule 40 or 80 piping and fittings must be supplied locally.

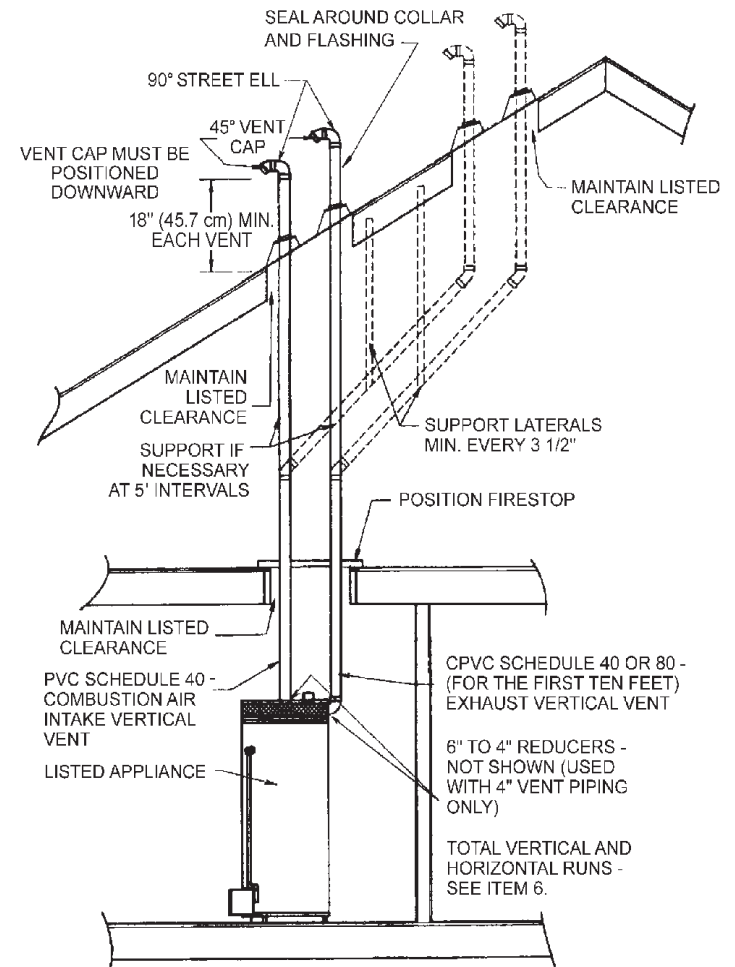

1. The water heater requires its own (separate) venting system.
2. Only 4" or 6" CPVC Schedule 40 or 80 piping and fittings are acceptable materials for the first ten feet of the outlet vent system.

3. 4" or 6" PVC Schedule 40 or CPVC Schedule 40 or 80 piping and fittings are acceptable materials for the inlet vent system and for the outlet vent system after the first ten feet. See vent length chart below.
4. It cannot be connected to existing vent piping or chimney.
5. It must terminate vertically to the outdoors.
6. **The total vertical and horizontal run cannot exceed the maximum length with number of 90° elbows as specified in the table below. If more elbows are required, the venting distance must be reduced 5' (1.5 m) for every 90° elbow:**

MODEL 100-400	MODEL 100-400	NUMBER OF 90° DEG. ELBOWS*
4" DIA. VENT MAX. LENGTH	6" DIA. VENT MAX. LENGTH	
45' (13.7 m)	110' (33.5 m)	1
40' (12 m)	105' (32 m)	2
35' (11 m)	100' (30.5 m)	3
30' (9 m)	95' (29 m)	4
25' (7.6 m)	90' (27.4 m)	5
20' (6 m)	85' (26 m)	6
15' (4.6 m)	80' (24.4 m)	7
10' (3 m)	75' (23 m)	8

*NOTE: Two 45° elbows are equivalent to one 90° elbow. One 90° elbow equals 5' (1.5 m) equivalent vent length.

7. **Minimum vent length is 18 inches when 4" pipe is used and 45 feet when 6" pipe is used.**

NOTE: See page 17 for instructions on cementing PVC or CPVC pipe and fittings.

GAS PIPING

WARNING

Make sure the gas supplied is the same type listed on the model rating plate. The inlet gas pressure must not exceed 10.5 in. water column (2.6kPa) for natural gas. The minimum inlet gas pressure listed on the rating plate is for the purpose of input adjustment.

WARNING

If the gas control valve is subjected to pressures exceeding 1/2 pound per square inch (3.5kPa), the damage to the

gas control valve could result in a fire or explosion from leaking gas.

WARNING

If the main gas line shutoff serving all gas appliances is used, also turn "OFF" the gas at each appliance. Leave all gas appliances shut off until the water heater installation is complete.

CORRECT GAS PIPE SIZE FOR WATER HEATERS OPERATING ON NATURAL GAS							
TOTAL INPUT BTU/HR	DISTANCE TO METER, IN FEET						
	30	60	90	120	150	180	210
300,000	1 1/4	1 1/4	1 1/4	1 1/2	1 1/2	1 1/2	1 1/2
400,000	1 1/4	1 1/2	1 1/2	1 1/2	2	2	2

A gas line of sufficient size must be run to the water heater. Consult the current edition of National Fuel Gas Code ANSI Z223.1, also referred to as NFPA 54 and the gas company concerning pipe size.

There must be:

- A readily accessible manual shut off valve in the gas supply line serving the water heater, and
- A drip leg (sediment trap) ahead of the gas control valve to help prevent dirt and foreign materials from entering the gas control valve.
- A flexible gas connector or a ground joint union between the shutoff valve and control valve to permit servicing of the unit.

Be sure to check all the gas piping for leaks before lighting the water heater. Use a soapy water solution, not a match or open flame. Rinse off soapy solution and wipe dry.

When installed at elevations above 2,000' (610 m), input ratings should be reduced at the rate of 4 percent for each 1,000' (305 m) above sea level.

WARNING

The appliance and its gas connection must be leak tested before placing the appliance in operation.

WARNING

The appliance and its individual shutoff valve must be disconnected from the gas supply piping system during any pressure testing of that system at test pressures in excess of 1/2 pound per square inch (3.5kPa).

The appliance must be isolated from the gas supply piping system by closing its individual manual shutoff valve during any pressure testing of the gas supply piping system at test pressures equal to or less than 1/2 pound per square inch (3.5kPa).

WARNING

Contaminants in the gas lines may cause improper operation of the gas control valve that may result in fire or explosion.

Before attaching the gas line be sure that all gas pipe is clean on the inside. To trap any dirt or foreign material in the gas supply line, a drip leg (sometimes called a sediment trap) must be incorporated in the piping. The drip leg must be readily accessible. Install in accordance with the "Gas Piping" section. Refer to the current edition of the National Fuel Gas Code, ANSI Z223.1, also referred to as NFPA 54.

SEDIMENT TRAP

A sediment trap shall be installed as close to the inlet of the water heater as practical at the time or water heater installation. The sediment trap shall be either a tee fitting with a capped nipple in the bottom outlet or other device recognized as an effective sediment trap. If a tee fitting is used, it shall be installed in conformance with one of the methods of installation shown.

GAS METER SIZE - CITY GASES ONLY

Be sure that the gas meter has sufficient capacity to supply the full rated gas input of the water heater as well as the requirements of all other gas fired equipment supplied by the meter. If the gas meter is too small, ask the gas company to install a larger meter having adequate capacity.

Connecting the gas piping to the gas control valve of the water heater can be accomplished by either of the two methods shown.

GAS PIPING WITH FLEXIBLE CONNECTOR

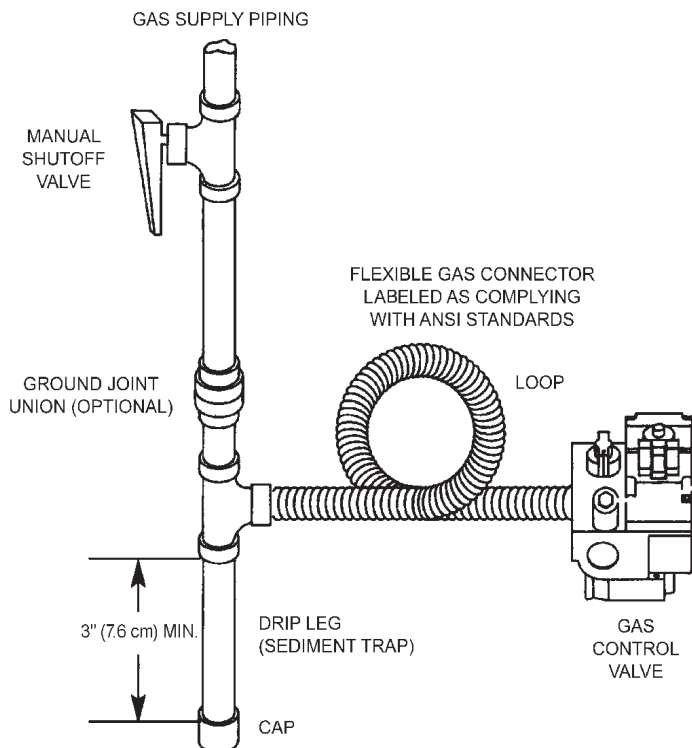

GAS PIPING WITH ALL BLACK IRON PIPE TO GAS CONTROL

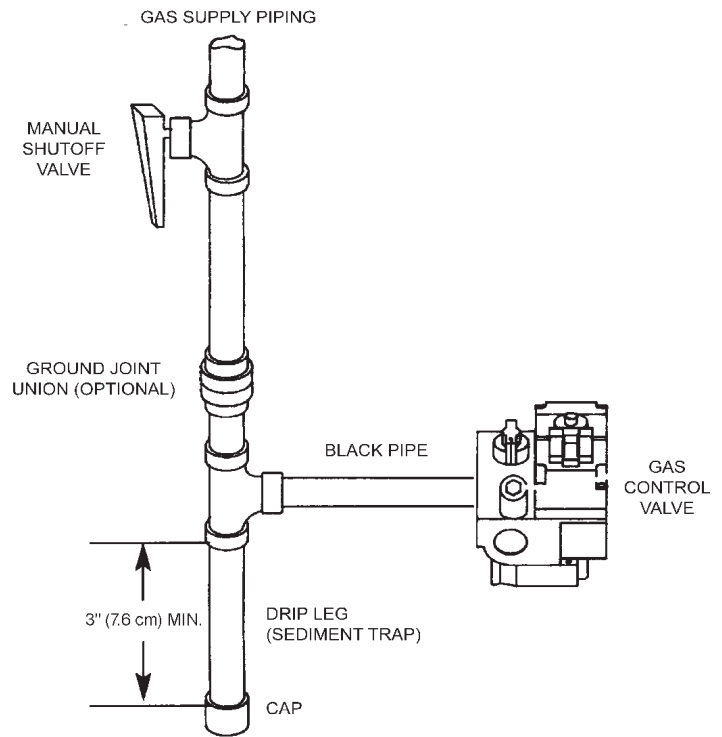

OPERATING INSTRUCTIONS FOR MODEL 100-400 BEFORE OPERATING THE WATER HEATER

1. Review the installation and instruction manual before turning on the electric power and gas supply to the water heater, to safeguard against a possible dangerous malfunction of the water heater.
2. The electrical supply to this water heater must NOT be turned on before the tank is completely full of water, the gas supply is available, and the venting system is completely installed.
3. Because there is normally a certain amount of air in a gas line when a new water heater has been installed, it may be necessary to re-sequence the water heater several times before it lights on the initial start-up.
4. Turn on electrical and gas supply to the water heater. Turn the toggle switch on. Turn the gas cock knob completely on. Go to "Operational Sequence" and follow the operation of the water heater to insure it is operating properly.

⚠ WARNING
AN ODORANT IS ADDED TO THE GAS USED BY THIS WATER HEATER.

FOR YOUR SAFETY IF YOU SMELL GAS:

1. Do not try to light any appliance.
2. Do not touch any electrical switch; do not use any phone in your building.
3. Immediately call your gas supplier from a neighbor's phone. Follow the gas supplier's instructions.
4. If you cannot reach your gas supplier, call the fire department.

These models are equipped with an electrically operated venting system and an intermittent ignition system. For the pilot to light and the burner to come on, the water heater's thermostat must call for heat. Then the system will begin sequencing, each section proving itself before actual pilot ignition takes place.

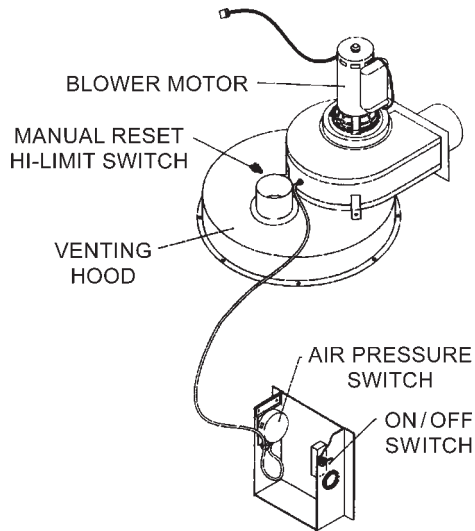

Before the water heater will operate:

1. The control system must be connected to a 110/120 power supply. This control system has an overall rating of 12 amps or less. The water heater must be securely and adequately grounded in accordance with the local codes or, in the absence of local codes, with the current edition of the National Electrical Code, ANSI/NFPA 70. The water heater must be electrically "grounded" by the installer. The unit will not operate unless it is properly grounded. This should be accomplished by using a grounded conductor from the service panel to the ground lug located in the junction box of the water heater
2. The ON/OFF toggle switch, located on the junction box must be in the "ON" position for the electrical control system of the water heater to operate.
3. The gas knob, located on the gas control valve must be turned to the "ON" position for gas to be able to flow.
4. The manual shut-off valve between the gas control valve and the burner assembly must be in the "ON" position.
5. The manual hi-limits must be in the closed position, see "Venting Manual Reset Switch" in the "For Your Information" section and "Compensating Thermostat with Manual E.C.O." in the "Temperature Regulation" section.

OPERATIONAL SEQUENCE- NATURAL GAS MODELS ONLY

When the thermostat calls for heat, a circuit is completed to the blower. When the blower has achieved sufficient venting, the air pressure switch will close. A 24 volt circuit will be completed through the venting manual reset switch and on to the ignition module.

The ignition module will then complete a circuit simultaneously to the spark ignitor, and to the gas pilot valve solenoid. The spark ignitor will begin sparking and the gas pilot solenoid will open, allowing gas to pass to the pilot. When a pilot flame has been established, the flame sensor in the pilot burner assembly will signal the ignition module, shutting off the spark ignitor. The ignition module will now complete a circuit to the gas control valve solenoid, which will open, and allow gas to pass to the burner. Once the thermostat has been satisfied, the electrical circuits will open and the burners and blower will shut off.

SAFETY SEQUENCE- NATURAL GAS MODELS ONLY

During a period when the thermostat is calling for heat and there was an interruption of the pilot flame, the gas valve solenoid will close instantly shutting off the supply of gas to the burner. The pilot valve solenoid will remain open allowing gas to flow to the pilot. The ignition module will complete a circuit to the spark ignitor, which will begin sparking, and the blower stays on.

1. If the pilot flame is reestablished the gas valve solenoid will open allowing gas to the burner, and the water heater will resume operation.
2. If the pilot flame is not reestablished the gas valve solenoid will remain closed. The blower will continue to run. The pilot valve solenoid will remain open allowing gas to pass to the pilot. The spark ignitor will continue sparking until the pilot flame is reestablished, or the water heater is re-sequenced by turning the ON/OFF toggle switch "OFF" and then "ON".

ROBERTSHAW CONTROL SYSTEM - NATURAL GAS

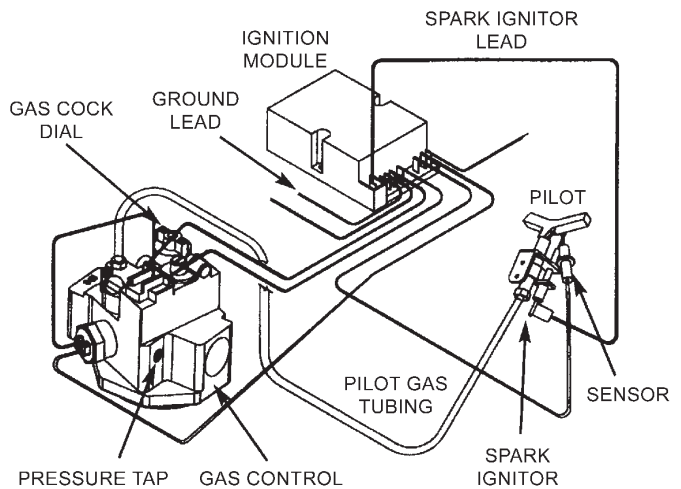

FOR YOUR SAFETY READ BEFORE OPERATING

WARNING

If you do not follow these instructions exactly, a fire or explosion may result causing property damage, personal injury or loss of life.

- A. This appliance is equipped with an ignition device which automatically lights the pilot. **Do not try to light the pilot by hand.**
- B. BEFORE OPERATING smell all around the appliance area for gas. Be sure to smell next to the floor because some gas is heavier than air and will settle on the floor.
- WHAT TO DO IF YOU SMELL GAS
- Do not try to light any appliance.
 - Do not touch any electric switch; do not use any phone in your building.
 - Immediately call your gas supplier from a neighbor's phone. Follow the gas supplier's instructions.
- If you cannot reach your gas supplier, call the fire department.
- C. Use only your hand to push in or turn the gas control knob. Never use tools. If the knob will not push in or turn by hand, don't try to repair it, call a qualified service technician. Force or attempted repair may result in a fire or explosion.
- D. Do not use this appliance if any part has been under water. Immediately contact a qualified service technician or contractor to replace a flooded water heater. Do not attempt to repair the unit! It must be replaced!

OPERATING INSTRUCTIONS

1. STOP! Read the safety information above on this label.
2. Turn off all electrical power to the water heater.
3. Remove thermostat access cover.
4. Set the thermostat to lowest setting.

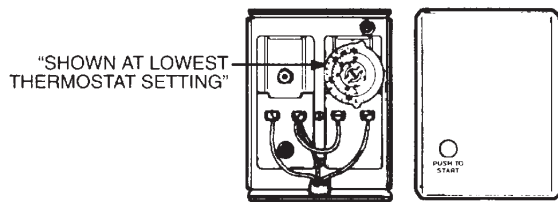

5. This appliance is equipped with an ignition device which automatically lights the pilot. **Do not try to light the pilot by hand.**
6. Turn knob on gas control clockwise  to "OFF" position.

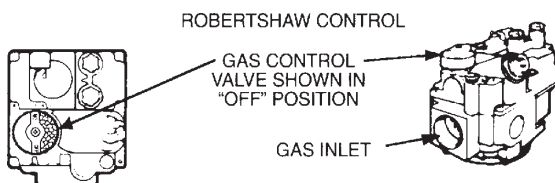

7. Wait five (5) minutes to clear out any gas. If you then smell gas, STOP! Follow "B" in the safety information above on this label. If you do not smell gas, go to the next step.
8. At arms length away, turn gas control knob counter-

clockwise  to the full "ON" position. **WARNING**

Do not use gas control knob to regulate gas flow.

9. At arms length away, set the thermostat to desired setting. The 120°F (67°C) setting which approximates 120°F (67°C) is preferred starting point. If hotter water is desired, see instruction manual and "warning" below.
10. Replace thermostat access cover.
11. Turn on all electric power to the appliance.
12. If the appliance will not operate, follow the instructions "To Turn Off Gas To Appliance" and call your service technician or gas supplier.

WARNING

Hotter water increases the risk of scald injury. Before changing temperature setting see instruction manual. For operation at outlet water temperature not in excess of 180°F (82°C).

TO TURN OFF GAS TO APPLIANCE

1. Turn off all electric power to the appliance if service is to be performed.
2. Remove thermostat access cover.
3. Set the thermostat to lowest setting.
4. Turn gas control knob clockwise  to "OFF" position. **DO NOT FORCE.**
5. Replace thermostat access cover.

TEMPERATURE REGULATION

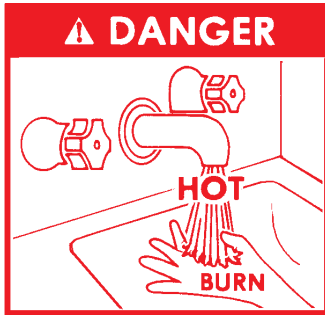

⚠ DANGER

HOT WATER CAN SCALD: WATER HEATERS ARE INTENDED TO PRODUCE HOT WATER. WATER HEATED TO A TEMPERATURE THAT WILL SATISFY SPACE HEATING, CLOTHES WASHING, DISH WASHING, AND OTHER SANITIZING NEEDS CAN SCALD AND PERMANENTLY INJURE YOU UPON CONTACT. SOME PEOPLE ARE MORE LIKELY TO BE PERMANENTLY INJURED BY HOT WATER THAN OTHERS. THESE INCLUDE THE ELDERLY, CHILDREN, THE INFIRM, OR PHYSICALLY/MENTALLY HANDICAPPED. IF ANYONE USING HOT WATER IN YOUR HOME FITS INTO ONE OF THESE GROUPS OR IF THERE IS A LOCAL CODE OR STATE LAW REQUIRING A SPECIFIC HOT WATER TEMPERATURE AT THE TAP, THEN YOU MUST TAKE SPECIAL PRECAUTIONS. NEVER ALLOW SMALL CHILDREN TO USE A HOT WATER TAP, OR TO DRAW THEIR OWN BATH WATER. NEVER LEAVE A CHILD OR HANDICAPPED PERSON UNATTENDED IN A BATHTUB OR SHOWER.

It is recommended that lower water temperatures be used to avoid the risk of scalding. It is further recommended, in all cases, that the water temperature be set for the lowest temperature that satisfies your hot water needs. This will also provide the most energy efficient operation of the water heater.

SETTING THE WATER HEATER TEMPERATURE AT 120°F (49°C) WILL REDUCE THE RISK OF SCALDS. Some states require settings at specific lower temperatures.

Short repeated heating cycles caused by small hot water uses can cause temperatures at the point of use to exceed the thermostat setting by up to 20°F (13°C). If you experience this type of use you should consider using lower temperature settings to reduce scald hazards.

Valves for reducing the point-of-use temperature by mixing cold and hot water are available. Also available are inexpensive devices that attach to faucets to limit hot water temperatures. Contact a licensed plumber or the local plumbing authority.”

Temperature Settings	Time to Produce 2nd & 3rd Degree Burns on Adult Skin
180°F (82°C)	Nearly Instantaneous
170°F (77°C)	Nearly Instantaneous
160°F (71°C)	About 1/2 Second
150°F (65°C)	About 1 - 1/2 Seconds
140°F (60°C)	Less than 5 Seconds
130°F (54°C)	About 30 Seconds
120°F (49°C)	More than 5 Minutes

To adjust thermostat setting, remove outer cover of the thermostat. The thermostat's adjustment dial is labeled with a range of settings between 120°F (49° C) to 180°F (82° C).

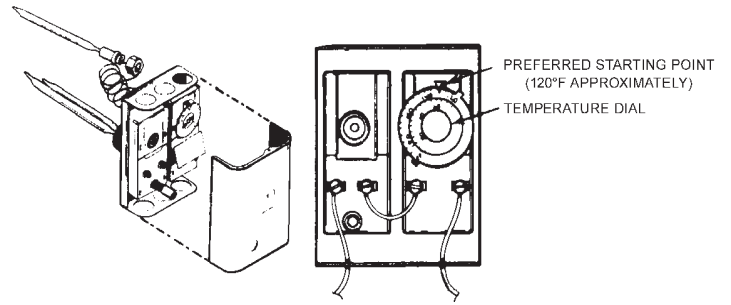

SHOULD OVERHEATING OCCUR OR THE GAS SUPPLY FAIL TO SHUT OFF, TURN “OFF” THE MANUAL GAS CONTROL VALVE TO THE APPLIANCE.

START UP CONDITIONS

CONDENSATION

Whenever the water heater is filled with cold water, a certain amount of condensation will form while the burner is on. A water heater may appear to be leaking when in fact the water is condensation. This usually happens:

- When a new water heater is filled with cold water for the first time.
- When gas burns and water vapor is produced in water heaters, particularly high efficiency models where flue temperatures are lower.
- When you use large amounts of hot water in a short time and the refill water is very cold.

Moisture from the products of combustion condense on the cooler tank surfaces and form drops of water which may fall onto the burner or other hot surfaces to produce a “sizzling” or “frying” noise.

Excessive condensation can cause pilot outage due to water running down the flue tube onto the main burner and putting out the pilot.

Because of the suddenness and amount of water, condensation water may be diagnosed as a “tank leak”. After the water in the tank warms up (about 1-2 hours), the condition should disappear.

Do not assume the water heater is leaking until there has been enough time for the water in the tank to warm up.

An undersized water heater will cause more condensation. The water heater must be sized properly to meet the demands for hot water including dishwashers, washing machines and shower heads.

Excessive condensation may be noticed during the winter and early spring months when incoming water temperatures are at their lowest.

Good venting is essential for a gas fired water heater to operate properly as well as to carry away products of combustion and water vapor.

SMOKE/ODOR

It is not uncommon to experience a small amount of smoke and odor during the initial start-up. This is due to burning off of oil from metal parts, and will disappear in a short while.

THERMAL EXPANSION

Water supply systems may, because of such events as high line pressure, frequent cutoffs, the effects of water hammer among others, have installed devices such as pressure reducing valves, check valves, back flow preventers, etc... to control these types of problems. When these devices are not equipped with an internal by-pass, and no other measures are taken, the devices cause the water system to be closed. As water is heated, it expands (thermal expansion) and closed systems do not allow for the expansion of heated water.

The water within the water heater tank expands as it is heated and increases the pressure of the water system. If the relieving point of the water heater's temperature-pressure relief valve is reached, the valve will relieve the excess pressure. **The temperature-pressure relief valve is not intended for the constant relief of thermal expansion.** This is an unacceptable condition and must be corrected.

Closed systems require installation of a thermal expansion tank. Failure to do so voids the limited warranty for this water heater.

STRANGE SOUNDS

Possible noises due to expansion and contraction of some metal parts during periods of heat-up and cool-down do not represent harmful or dangerous conditions.

Condensation causes sizzling and popping with the burner area during heating and cooling periods and should be considered normal. See "Condensation" in this section.

OPERATIONAL CONDITIONS

SMELLY WATER

In each water heater there is installed at least one anode rod (see parts section) for corrosion protection of the tank. Certain water conditions will cause a reaction between this rod and the water. The most common complaint associated with the anode rod is one of a "rotten egg smell". This odor is derived from hydrogen sulfide gas dissolved in the water. The smell is the result of four factors which must all be present for the odor to develop:

- a concentration of sulfate in the supply water.
- little or no dissolved oxygen in the water.
- a sulfate reducing bacteria within the water heater. (This harmless bacteria is non-toxic to humans.)
- an excess of active hydrogen in the tank. This is caused by the corrosion protective action of the anode.

Smelly water may be eliminated or reduced in some water heater models by replacing the anode(s) with one of less active material, and then chlorinating the water heater tank and all hot water lines. Contact the local water heater supplier for further information concerning an Anode Replacement Kit #9000029 and this Chlorination Treatment.

If smelly water persists after anode replacement and chlorination treatment, then the water supply must be chlorinated or aerated to eliminate the bacteria.

DO NOT REMOVE THE ANODE LEAVING THE TANK UNPROTECTED. BY DOING SO, ALL WARRANTY ON THE WATER HEATER TANK IS VOIDED.

"AIR" IN HOT WATER FAUCETS

⚠ WARNING

HYDROGEN GAS: HYDROGEN GAS CAN BE PRODUCED IN A HOT WATER SYSTEM THAT HAS NOT BEEN USED FOR A LONG PERIOD OF TIME (GENERALLY TWO WEEKS OR MORE). HYDROGEN GAS IS EXTREMELY FLAMMABLE AND EXPLOSIVE. TO PREVENT THE POSSIBILITY OF INJURY UNDER THESE CONDITIONS, WE RECOMMEND THE HOT WATER FAUCET BE OPENED FOR SEVERAL MINUTES AT THE KITCHEN SINK BEFORE ANY ELECTRICAL APPLIANCES WHICH ARE CONNECTED TO THE HOT WATER SYSTEM ARE USED (SUCH AS A DISHWASHER OR WASHING MACHINE). IF HYDROGEN GAS IS PRESENT, THERE WILL PROBABLY BE AN UNUSUAL SOUND SIMILAR TO AIR ESCAPING THROUGH THE PIPE AS THE HOT WATER FAUCET IS OPENED. THERE MUST BE NO SMOKING OR OPEN FLAME NEAR THE FAUCET AT THE TIME IT IS OPEN.

VENTING MANUAL RESET SWITCH

There is a venting manual reset switch located on top of the venting hood. If the switch is activated, before resetting the switch, check for flue blockage in the venting system. To reset, press the red button.

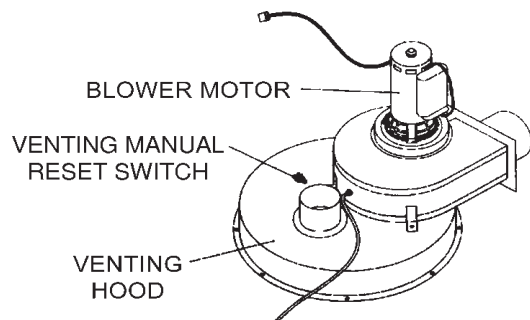

HIGH TEMPERATURE SHUT OFF SYSTEM

This water heater is equipped with an automatic gas shut off system. This system works when high water temperatures are present.

E.C.O.

The E.C.O. will activate if the water temperature exceeds 200°F and will not reset itself. If it is activated, contact a service agent to determine the cause.

⚠ WARNING

Should overheating occur or the gas supply fail to shut off, turn "off" the manual gas control valve to the appliance.

NOT ENOUGH OR NO HOT WATER

1. Check the manual gas shut off valve to be sure it is open.
2. Check the pilot flame. It may have gone out. All models have an opening behind the outer door for viewing the pilot.
3. If the pilot is not lit, follow the "Lighting" instructions in this manual or located above the gas control valve on the water heater to relight the

pilot. If the water was extremely hot and is now cold, the high limit safety temperature shut off may have put out the burner and pilot. Refer to "High Temperature Shut Off System" in this section.

4. The gas control knob must be turned to the "ON" position.
5. The temperature adjustment dial may be set too low. See the "Temperature Regulation" section.
6. The gas company can check the gas input to see if it is correct. An underfired water heater will not heat water as quickly.
7. Look for leaking or open hot water faucets. Make sure all are closed.
8. The cold water inlet temperature may be colder during the winter months. It will take longer to heat the water and seem like less hot water.
9. If you cannot find what is wrong, call the local gas utility and/or plumbing contractor.

WATER IS TOO HOT

1. The temperature adjustment dial may be set too high. See the "Temperature Regulation" section.

NOTE: A period of time is necessary after an adjustment has been made for the water temperature to reach the new temperature setting.

2. If lower temperature settings will not lower the water temperature, shut off the water heater and call the local gas utility.

VENTING SYSTEM INSPECTION

At least once a year a visual inspection should be made of the venting system. You should look for:

1. Obstructions which could cause improper venting. The combustion and ventilation air flow must not be obstructed.
2. Damage or deterioration which could cause improper venting or leakage of combustion products.

⚠ WARNING

BE SURE THE VENT PIPING IS PROPERLY CONNECTED TO PREVENT ESCAPE OF DANGEROUS FLUE GASSES WHICH COULD CAUSE DEADLY ASPHYXIATION.

⚠ WARNING

OBSTRUCTIONS AND DETERIORATED VENT SYSTEMS MAY PRESENT SERIOUS HEALTH RISK OR ASPHYXIATION.

⚠ WARNING

CHEMICAL VAPOR CORROSION OF THE FLUE AND VENT SYSTEM MAY OCCUR IF AIR FOR COMBUSTION CONTAINS CERTAIN CHEMICAL VAPORS. SPRAY CAN PROPELLANTS, CLEANING SOLVENTS, REFRIGERATOR AND AIR CONDITIONER REFRIGERANTS, SWIMMING POOL CHEMICALS, CALCIUM AND SODIUM CHLORIDE, WAXES, BLEACH AND PROCESS CHEMICALS ARE TYPICAL COMPOUNDS WHICH ARE POTENTIALLY CORROSIVE.

⚠ WARNING

IF AFTER INSPECTION OF THE VENT SYSTEM YOU FOUND SOOTING OR DETERIORATION, SOMETHING IS WRONG. CALL THE LOCAL GAS UTILITY TO CORRECT THE PROBLEM AND CLEAN OR REPLACE THE FLUE AND VENTING BEFORE RESUMING OPERATION OF THE WATER HEATER.

BURNER INSPECTION

⚠ WARNING

FLOOD DAMAGE TO A WATER HEATER MAY NOT BE READILY VISIBLE OR IMMEDIATELY DETECTIBLE. HOWEVER, OVER A PERIOD OF TIME A FLOODED WATER HEATER WILL CREATE DANGEROUS CONDITIONS WHICH CAN CAUSE DEATH, SERIOUS BODILY INJURY, OR PROPERTY DAMAGE. CONTACT A QUALIFIED SERVICE TECHNICIAN OR CONTRACTOR TO REPLACE A FLOODED WATER HEATER. DO NOT ATTEMPT TO REPAIR THE UNIT! IT MUST BE REPLACED!

At least once a year a visual inspection should be made of the main burner and pilot burner. The drawing is for your reference.

You should check for sooting which is not normal and will impair proper combustion.

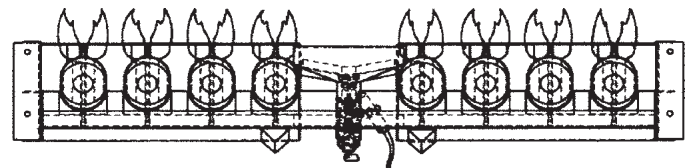

MODEL 100-400

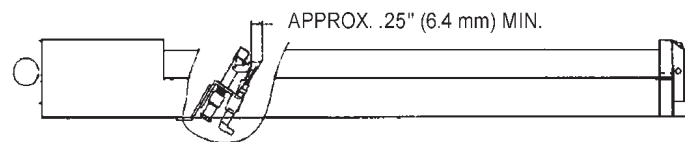

⚠ WARNING

SOOT BUILD-UP INDICATES A PROBLEM THAT REQUIRES CORRECTION BEFORE FURTHER USE. TURN "OFF" GAS TO WATER HEATER AND LEAVE "OFF" UNTIL REPAIRS ARE MADE, BECAUSE FAILURE TO CORRECT THE CAUSE OF THE SOOTING CAN RESULT IN A FIRE CAUSING DEATH, SERIOUS BODILY INJURY, OR PROPERTY DAMAGE.

BURNER CLEANING

In the event your burner needs cleaning, use the following instructions:

If inspection of the burner shows that cleaning is required, turn the gas control knob clockwise (↻) to the "OFF" position.

Loose deposits on or around the burner can be removed by carefully using the hose of a vacuum cleaner. If the burner needs to be removed

for cleaning, call the local gas utility to remove and clean the burner and correct the problem that required the burner to be cleaned.

HOUSEKEEPING

Vacuum around base of water heater for dust, dirt, and lint on a regular basis.

⚠ WARNING

TO INSURE SUFFICIENT VENTILATION AND COMBUSTION AIR SUPPLY, PROPER CLEARANCES FROM THE WATER HEATER MUST BE MAINTAINED. SEE "LOCATING THE NEW WATER HEATER" SECTION. COMBUSTIBLE MATERIALS SUCH AS CLOTHING, CLEANING MATERIALS, OR FLAMMABLE LIQUIDS, ETC. MUST NOT BE PLACED AGAINST OR ADJACENT TO THE WATER HEATER WHICH CAN CAUSE A FIRE.

TEMPERATURE-PRESSURE RELIEF VALVE OPERATION

The temperature-pressure relief valve must be manually operated at least once a year.

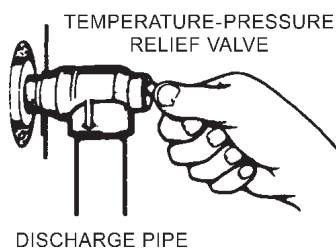

⚠ WARNING

WHEN CHECKING THE TEMPERATURE-PRESSURE RELIEF VALVE OPERATION, MAKE SURE THAT (1) NO ONE IS IN FRONT OF OR AROUND THE OUTLET OF THE TEMPERATURE-PRESSURE RELIEF VALVE DISCHARGE LINE, AND (2) THAT THE WATER MANUALLY DISCHARGED WILL NOT CAUSE ANY PROPERTY DAMAGE BECAUSE THE WATER MAY BE EXTREMELY HOT. IF AFTER MANUALLY OPERATING THE VALVE, IT FAILS TO COMPLETELY RESET AND CONTINUES TO RELEASE WATER, IMMEDIATELY CLOSE THE COLD WATER INLET TO THE WATER HEATER, FOLLOW THE DRAINING INSTRUCTIONS, AND REPLACE THE TEMPERATURE-PRESSURE RELIEF VALVE WITH A NEW ONE.

⚠ WARNING

IF THE TEMPERATURE-PRESSURE RELIEF VALVE ON THE APPLIANCE WEEPS OR DISCHARGES PERIODICALLY, THIS MAY BE DUE TO THERMAL EXPANSION. YOUR WATER HEATER MAY HAVE A CHECK VALVE INSTALLED IN THE WATER LINE OR A WATER METER WITH A CHECK VALVE. CONSULT THE WATER SUPPLIER AND/OR PLUMBING CONTRACTOR FOR FURTHER INFORMATION. DO NOT PLUG THE TEMPERATURE-PRESSURE RELIEF VALVE.

DRAINING

THE WATER HEATER SHOULD BE DRAINED IF BEING SHUT DOWN DURING FREEZING TEMPERATURES. ALSO PERIODIC DRAINING AND CLEANING OF SEDIMENT FROM THE TANK MAY BE NECESSARY.

1. TURN THE GAS CONTROL KNOB TO THE "OFF" POSITION.
 2. CLOSE THE COLD WATER INLET VALVE TO THE WATER HEATER.
 3. OPEN A NEARBY HOT WATER FAUCET AND LEAVE OPEN TO ALLOW FOR DRAINING.
 4. CONNECT A HOSE TO THE DRAIN VALVE AND TERMINATE TO AN ADEQUATE DRAIN.
 5. OPEN THE WATER HEATER DRAIN VALVE TO ALLOW FOR TANK DRAINING.
- NOTE: IF THE WATER HEATER IS GOING TO BE SHUT DOWN AND DRAINED FOR AN EXTENDED PERIOD, THE DRAIN VALVE SHOULD BE LEFT OPEN WITH HOSE CONNECTED ALLOWING WATER TO TERMINATE TO AN ADEQUATE DRAIN.**
6. CLOSE THE DRAIN VALVE.
 7. FOLLOW INSTRUCTIONS IN THE "FILLING THE WATER HEATER" SECTION.
 8. FOLLOW THE LIGHTING INSTRUCTIONS IN THE "LIGHTING" SECTION TO RESTART THE WATER HEATER.

SERVICE

If a condition persists or you are uncertain about the operation of the water heater, let a qualified person check it out. Call the local utility and/or plumbing contractor.

INSTALLATION DIAGRAMS

ONE TEMPERATURE - ONE HEATER VERTICAL STORAGE TANK FORCED CIRCULATION WITH OR WITHOUT BUILDING RECIRCULATION

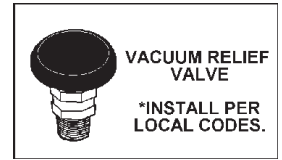
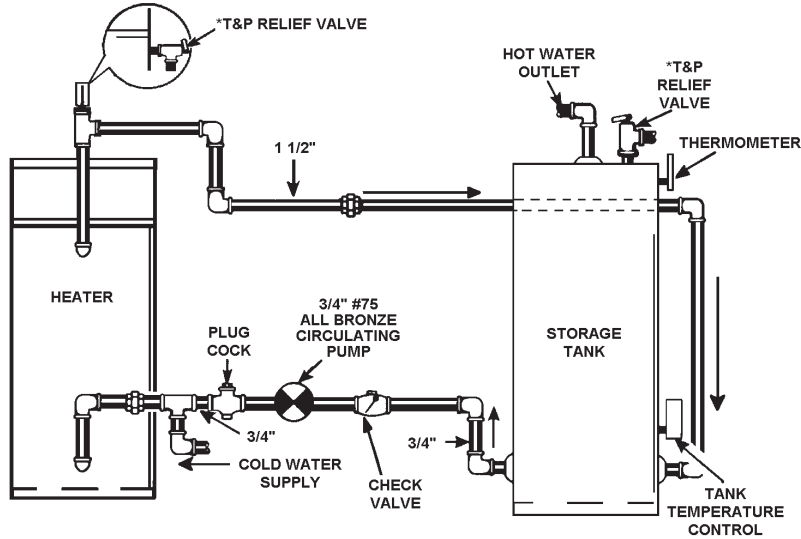
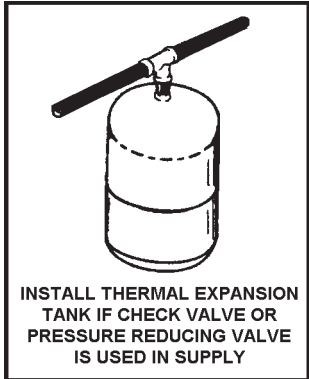

CAUTION: IF BUILDING COLD WATER SUPPLY HAS A BACK-FLOW PREVENTER, CHECK VALVE OR WATER METER WITH CHECK VALVE PROVISIONS FOR THERMAL EXPANSION OF WATER IN THE HOT WATER SYSTEM MUST BE PROVIDED

NOTE: CONNECT RETURN LINE FROM HOT WATER CIRCULATING LOOP (IF USED) TO COLD WATER INLET LINE.

* PIPE TO OPEN DRAIN

INSTALL IN ACCORDANCE WITH LOCAL CODES

ONE TEMPERATURE - ONE HEATER HORIZONTAL STORAGE TANK FORCED CIRCULATION WITH OR WITHOUT BUILDING RECIRCULATION



TEMPERATURE SETTING SHOULD NOT EXCEED SAFE TEMPERATURE AT FIXTURES. SEE WATER TEMPERATURE CONTROL WARNING ON PAGE 24. IF HIGHER PREHEAT TEMPERATURES ARE NECESSARY TO OBTAIN ADEQUATE BOOSTER OUTPUT, ADD AN ANTI-SCALD VALVE FOR HOT WATER SUPPLIED TO FIXTURES.

*PIPE TO OPEN DRAIN

INSTALL IN ACCORDANCE WITH LOCAL CODES

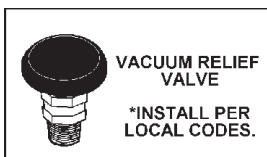
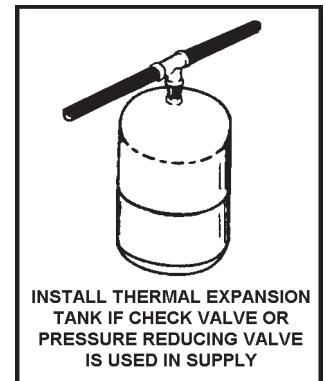
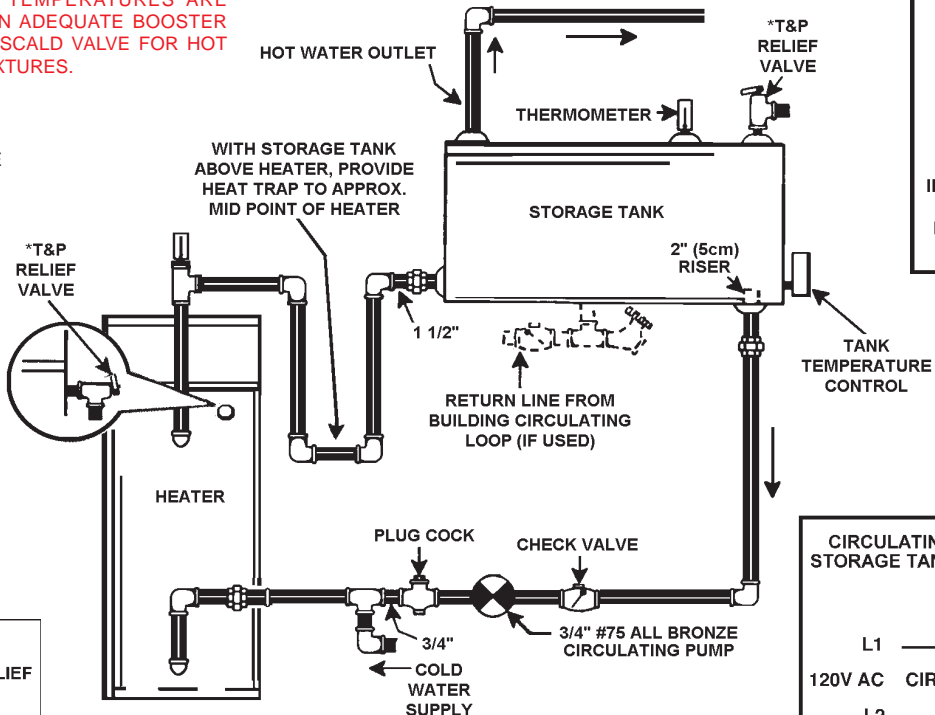

CIRCULATING PUMP WIRING DIAGRAM STORAGE TANK TEMPERATURE CONTROL

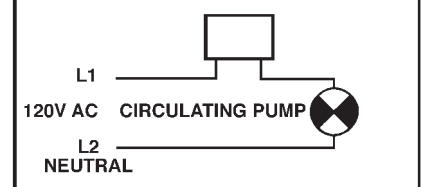

WIRING DIAGRAM FOR BOILER TO TANK LOOP AND/OR HOT WATER LOOP (IF USED).

TWO TEMPERATURE - ONE HEATER HIGH TEMPERATURE WITH OR WITHOUT BUILDING RECIRCULATION



TEMPERATURE SETTING SHOULD NOT EXCEED SAFE TEMPERATURE AT FIXTURES. SEE WATER TEMPERATURE CONTROL WARNING ON PAGE 24. IF HIGHER PREHEAT TEMPERATURES ARE NECESSARY TO OBTAIN ADEQUATE BOOSTER OUTPUT, ADD AN ANTI-SCALD VALVE FOR HOT WATER SUPPLIED TO FIXTURES.

CAUTION: IF BUILDING COLD WATER SUPPLY HAS A BACK-FLOW PREVENTER, CHECK VALVE OR WATER METER WITH CHECK VALVE PROVISIONS FOR THERMAL EXPANSION OF WATER IN THE HOT WATER SYSTEM MUST BE PROVIDED.

*PIPE RELIEF VALVE TO OPEN DRAIN.

NOTE: IF TEMPERED WATER IS RECIRCULATED, RETURN LINE SHOULD BE CONNECTED AT POINT "A".

INSTALL IN ACCORDANCE WITH LOCAL CODES.

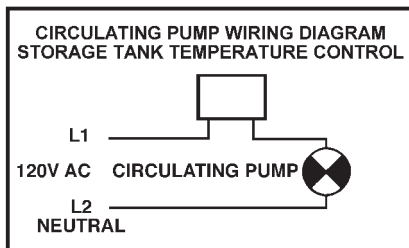
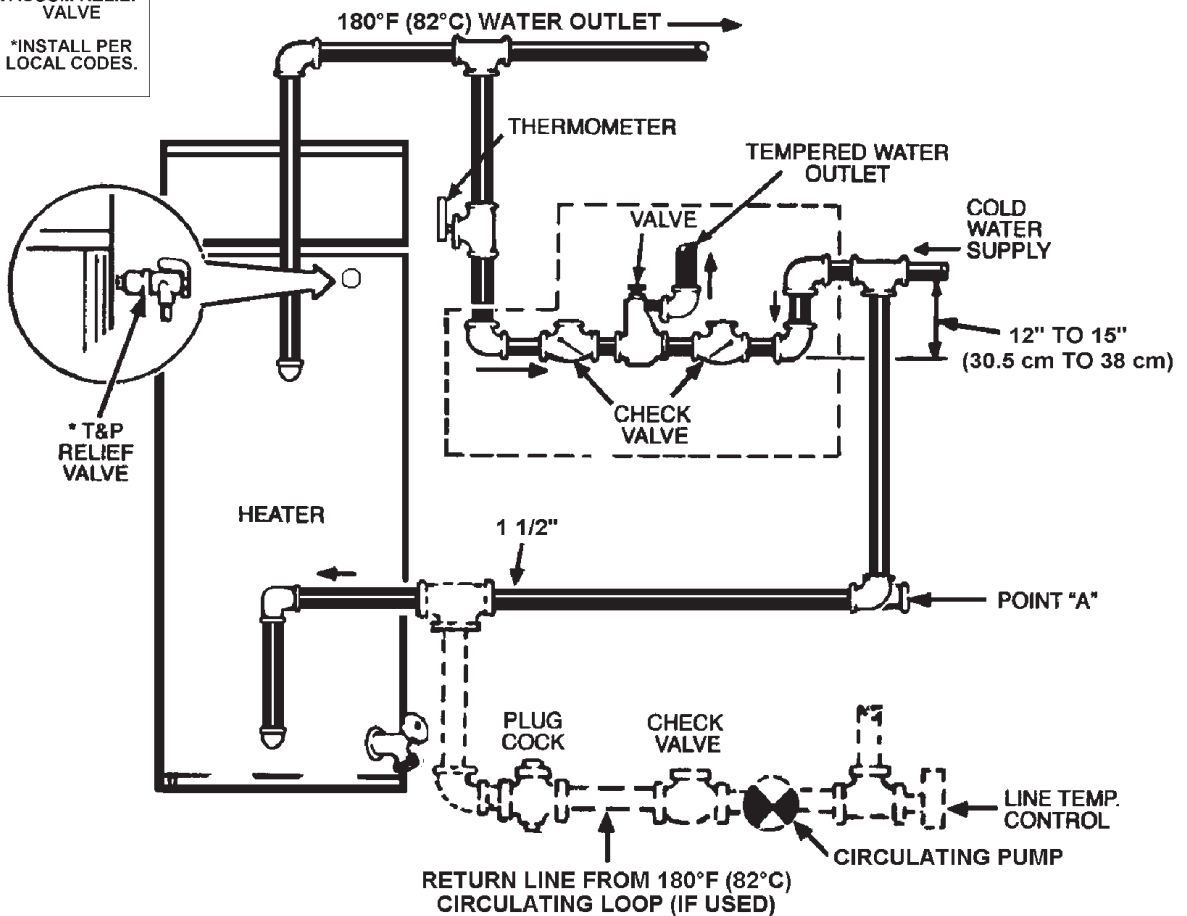
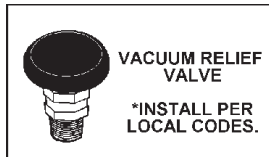
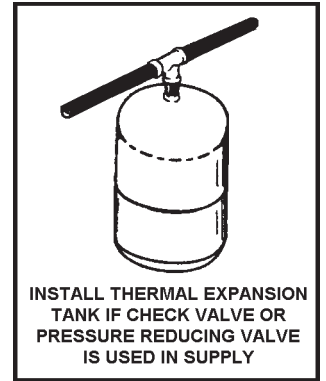

WIRING DIAGRAM FOR BOILER TO TANK LOOP AND/OR HOT WATER LOOP (IF USED).

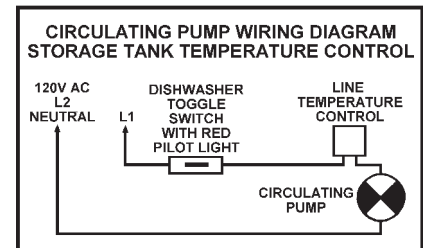

WIRING DIAGRAM FOR 180°F (82°C) LOOP (IF USED).

TWO TEMPERATURE - TWO HEATERS HIGH TEMPERATURE WITH OR WITHOUT BUILDING RECIRCULATION

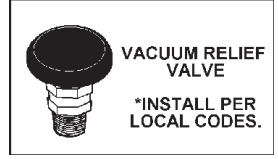
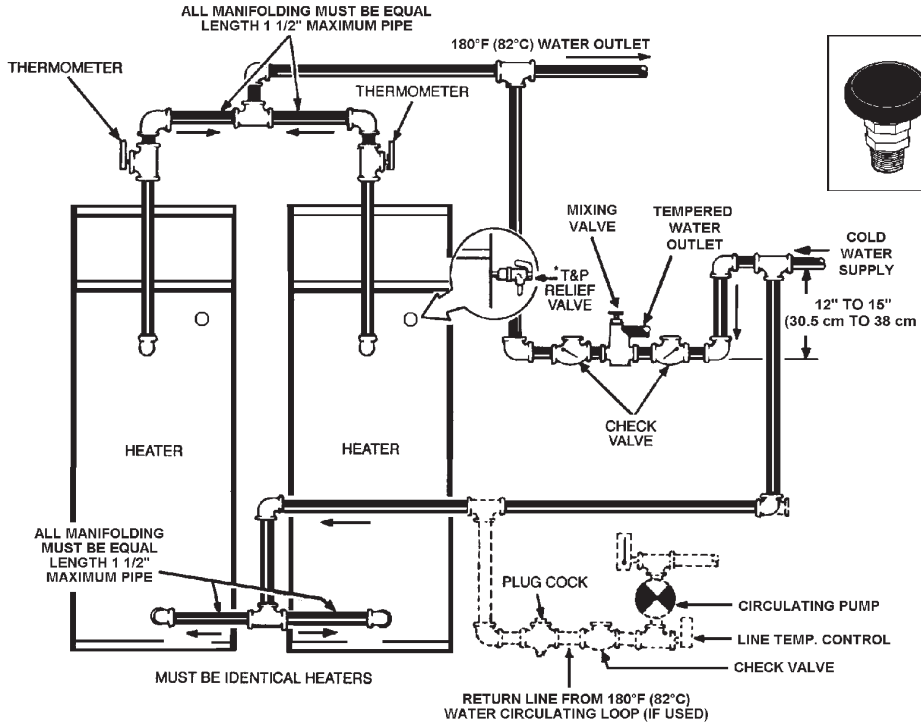
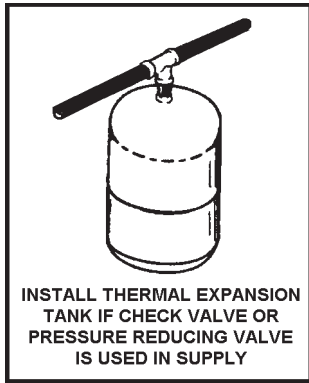

TWO TEMPERATURE - THREE HEATERS (TWO PRE-HEATERS/ONE BOOSTER HEATER) WITH OR WITHOUT BUILDING RECIRCULATION

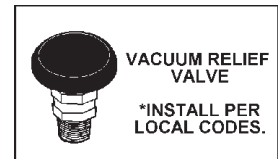
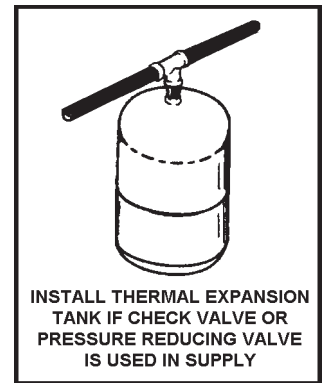
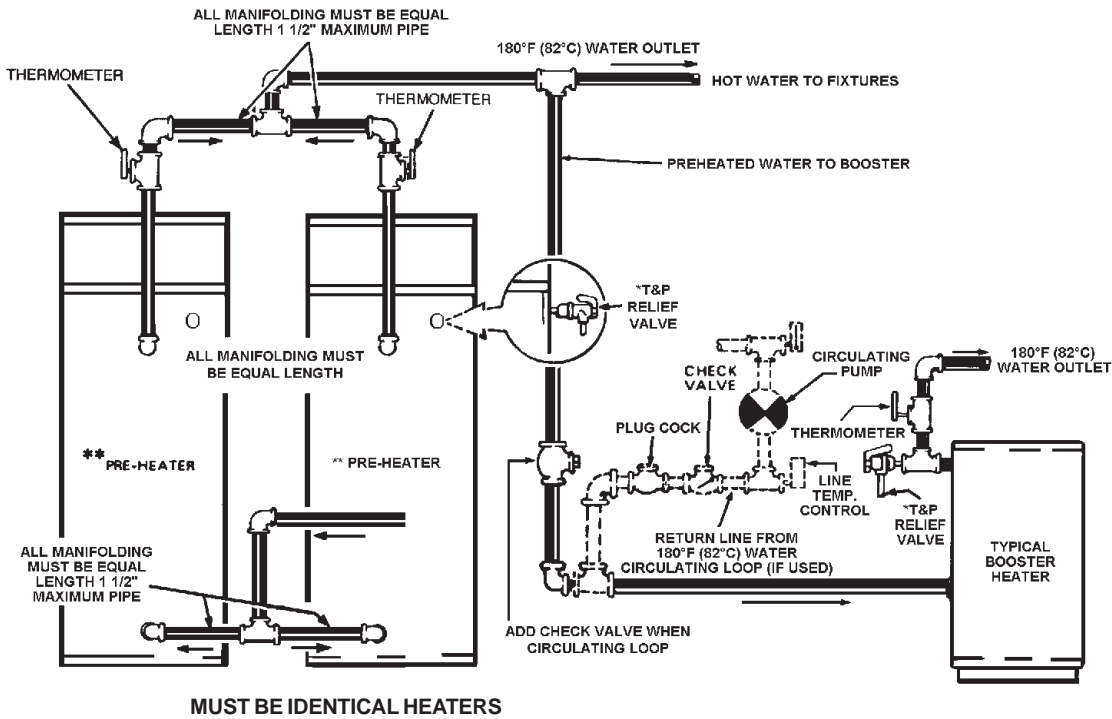

FOR MULTIPLE HEATER INSTALLATION SEE MANIFOLD KIT SPECIFICATIONS, PAGE 33.

CAUTION: IF BUILDING COLD WATER SUPPLY HAS A BACK-FLOW PREVENTER, CHECK VALVE OR WATER METER WITH CHECK VALVE PROVISIONS FOR THERMAL EXPANSION OF WATER IN THE HOT WATER SYSTEM MUST BE PROVIDED.



TEMPERATURE SETTING SHOULD NOT EXCEED SAFE TEMPERATURE AT FIXTURES. SEE WATER TEMPERATURE CONTROL WARNING ON PAGE 24. IF HIGHER PREHEAT TEMPERATURES ARE NECESSARY TO OBTAIN ADEQUATE BOOSTER OUTPUT, ADD AN ANTI-SCALD VALVE FOR HOT WATER SUPPLIED TO FIXTURES.

TWO TEMPERATURE - TWO HEATERS (ONE PRE-HEATER/ONE BOOSTER HEATER) WITH OR WITHOUT BUILDING RECIRCULATION



TEMPERATURE SETTING SHOULD NOT EXCEED SAFE TEMPERATURE AT FIXTURES. SEE WATER TEMPERATURE CONTROL WARNING ON PAGE 24. IF HIGHER PREHEAT TEMPERATURES ARE NECESSARY TO OBTAIN ADEQUATE BOOSTER OUTPUT, ADD AN ANTI-SCALD VALVE FOR HOT WATER SUPPLIED TO FIXTURES

* PIPE RELIEF VALVE TO OPEN DRAIN

** 140°F (60°C) TO 150°F (66°C) SHOULD BE MAXIMUM WATER TEMPERATURE MAINTAINED IN THE PRE-HEATERS.

120°F (49°C) SHOULD BE THE MINIMUM TEMPERATURE OF WATER IN THE PRE-HEATERS.

CONNECT CIRCULATING LINE FROM FIXTURES, IF USED, TO COLD WATER SUPPLY LINE OF PRE-HEATER.

CONNECT CIRCULATING LINE OF 180°F (82°C) OR BOOSTED WATER, IF USED, TO INLET WATER LINE TO BOOSTER.

INSTALL IN ACCORDANCE WITH LOCAL CODES.

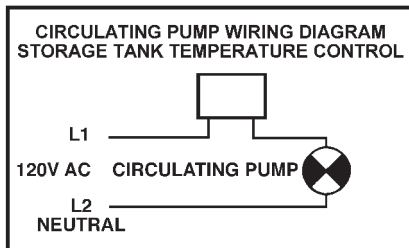
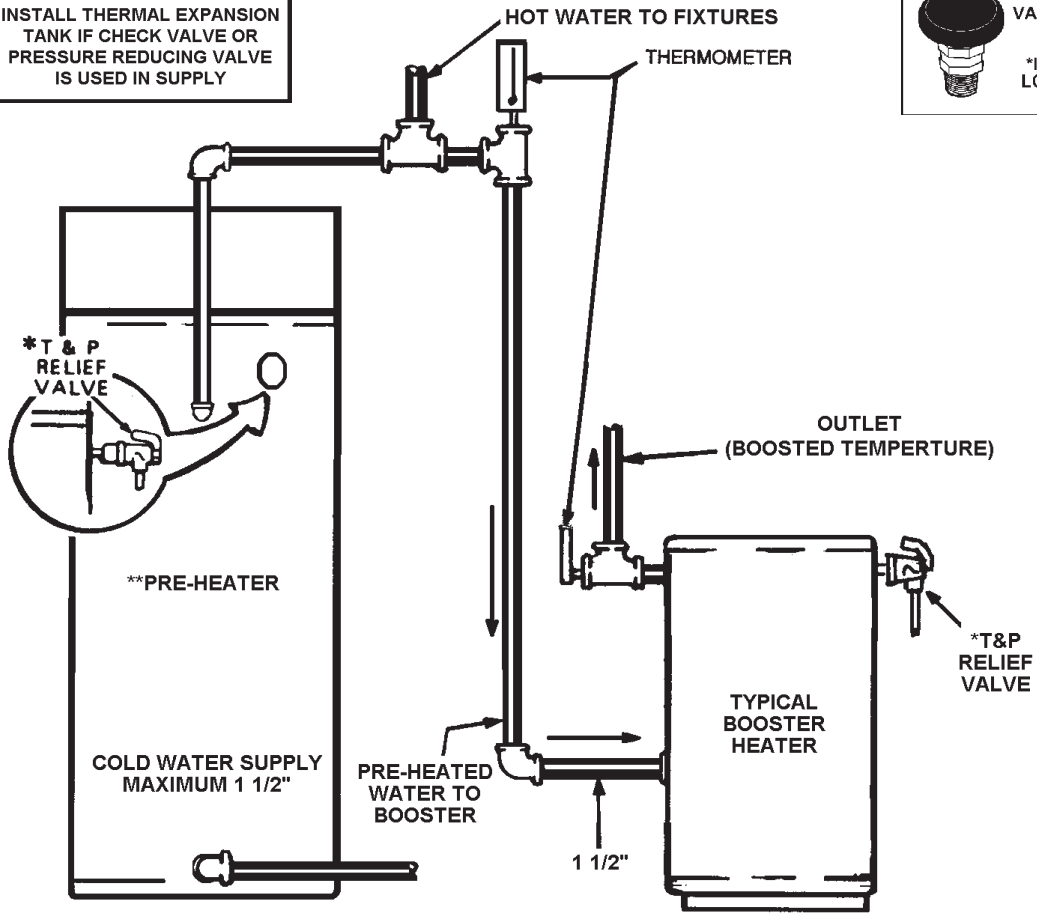
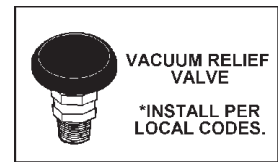
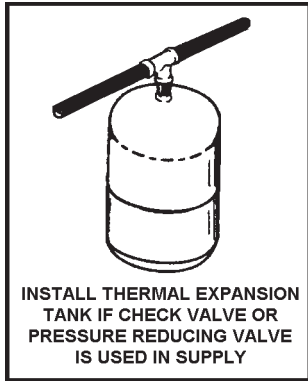

WIRING DIAGRAM FOR BOILER TO TANK LOOP AND/OR HOT WATER LOOP (IF USED).

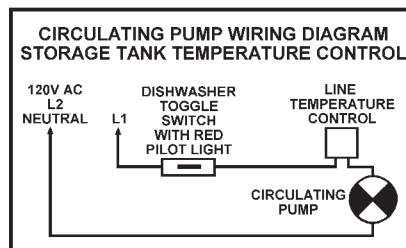

WIRING DIAGRAM FOR 180°F (82°C) LOOP (IF USED).

TWO TEMPERATURE - ONE HEATER HIGH TEMPERATURE WITH RECIRCULATION OF SANITIZING LOOP

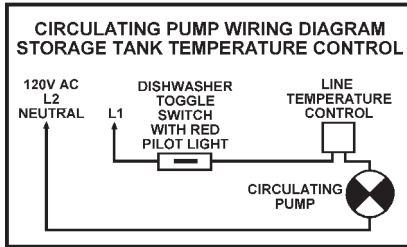

WIRING DIAGRAM FOR
180°F (82°C) LOOP (IF USED).

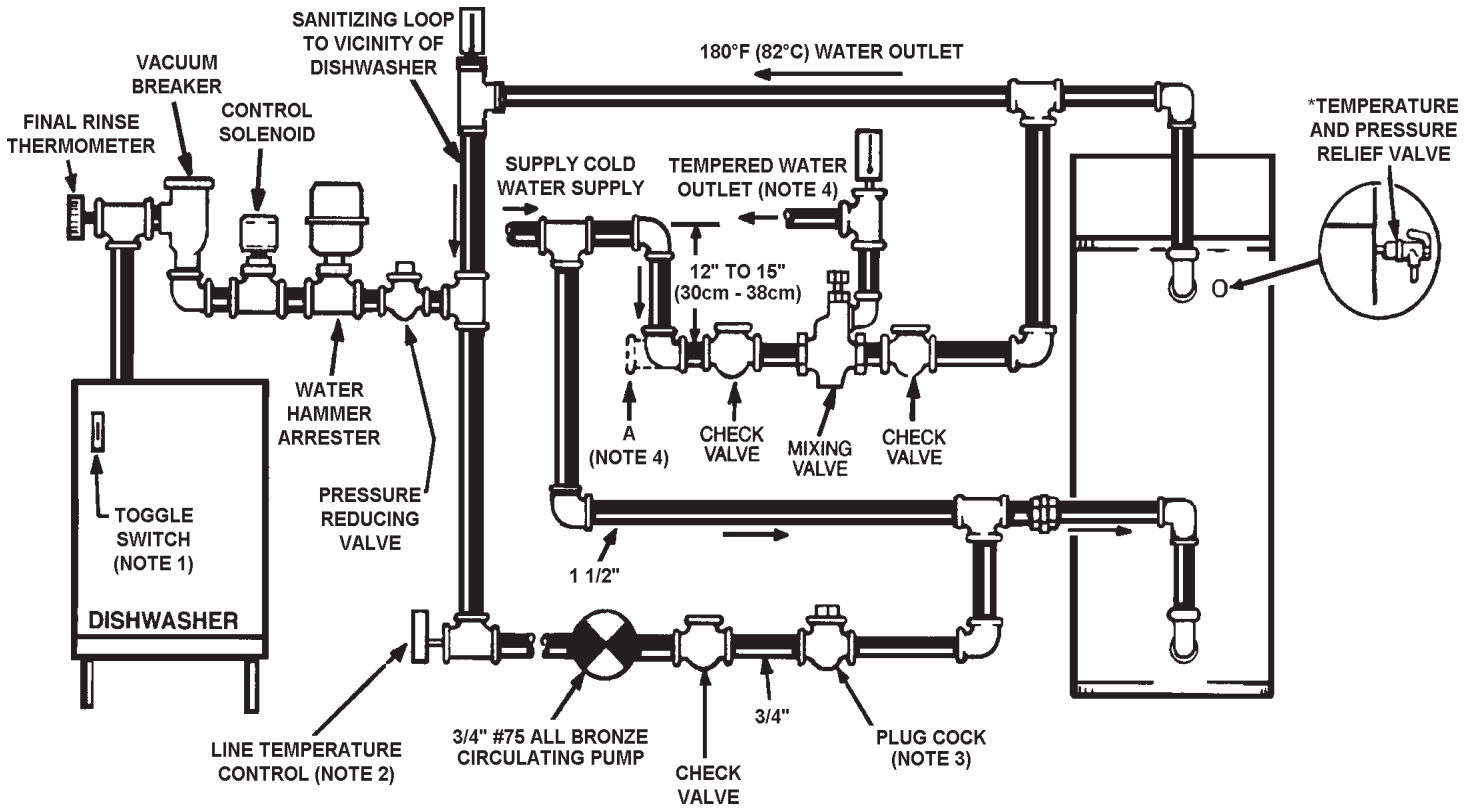
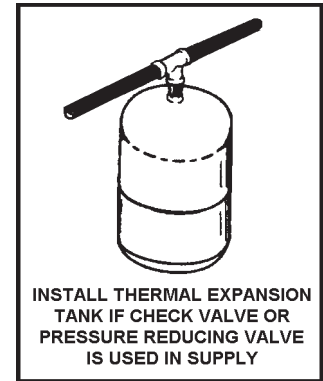
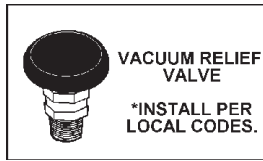

⚠ DANGER

TEMPERATURE SETTING SHOULD NOT EXCEED SAFE TEMPERATURE AT FIXTURES. SEE WATER TEMPERATURE CONTROL WARNING ON PAGE 24. IF HIGHER PREHEAT TEMPERATURES ARE NECESSARY TO OBTAIN ADEQUATE BOOSTER OUTPUT, ADD AN ANTI-SCALD VALVE FOR HOT WATER SUPPLIED TO FIXTURES.

CAUTION: IF BUILDING COLD WATER SUPPLY HAS A BACK-FLOW PREVENTER, CHECK VALVE OR WATER METER WITH CHECK VALVE PROVISIONS FOR THERMAL EXPANSION OF WATER IN THE HOT WATER SYSTEM MUST BE PROVIDED.

*PIPE RELIEF VALVE TO OPEN DRAIN

INSTALL IN ACCORDANCE WITH LOCAL CODES

NOTE 1: TOGGLE SWITCH CONTROLS 180°F (82°C) WATER CIRCULATION. INSTALL ON OR CLOSE TO DISHWASHER. TOGGLE SWITCH MUST BE CLOSED (ON) DURING THE RINSE OPERATION AND OPEN (OFF) WHEN DISHWASHER IS NOT OPERATING OR WHEN ON LONG STANDBY.

NOTE 2: INSTALL LINE TEMPERATURE CONTROL IN AN UNINSULATED TEE BEYOND THE DISHWASHER TAKEOFF IN THE SANITIZING LOOP. CONTROL SHOULD BE SET AT 185°F (85°C).

NOTE 3: ADJUST PLUG COCK SO THE SANITIZING LOOP FLOW RATE DOES NOT CAUSE UNNECESSARY TURBULENCE IN THE TANK.

NOTE 4: IF TEMPERED WATER IS RECIRCULATED, RETURN LINE SHOULD BE CONNECTED AT POINT A.

MANIFOLD KITS

Precision cut type "L" all copper A.O. Smith manifold kits assure water flow balance of all units. Without this balance, the full water heating and storage potential of the system cannot be achieved. Plus, the units with the higher water flow may have a shortened life. Unions shown in piping diagrams are not included in the manifold kits.

Dimensions shown are for minimum space occupied by the water heaters assemblies.

Space for the venting system and unit servicing must be added.

**TWO UNIT MANIFOLD KIT
(PART NO. 195686)**

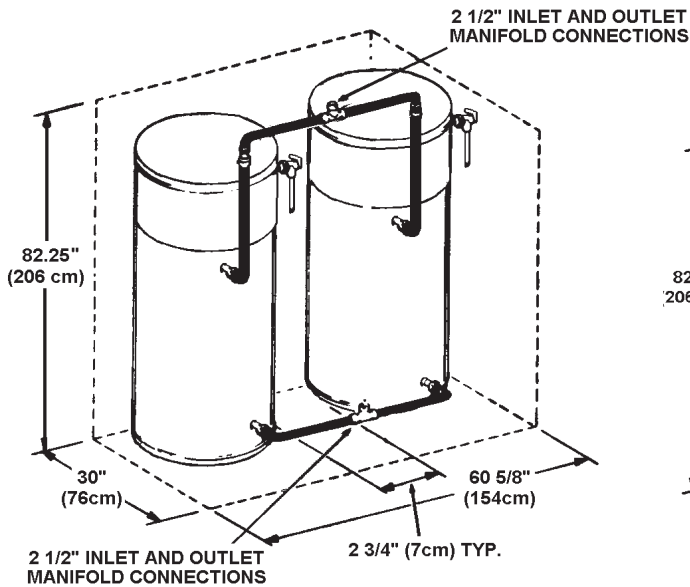

**THREE UNIT MANIFOLD KIT
(PART NO. 195687)**

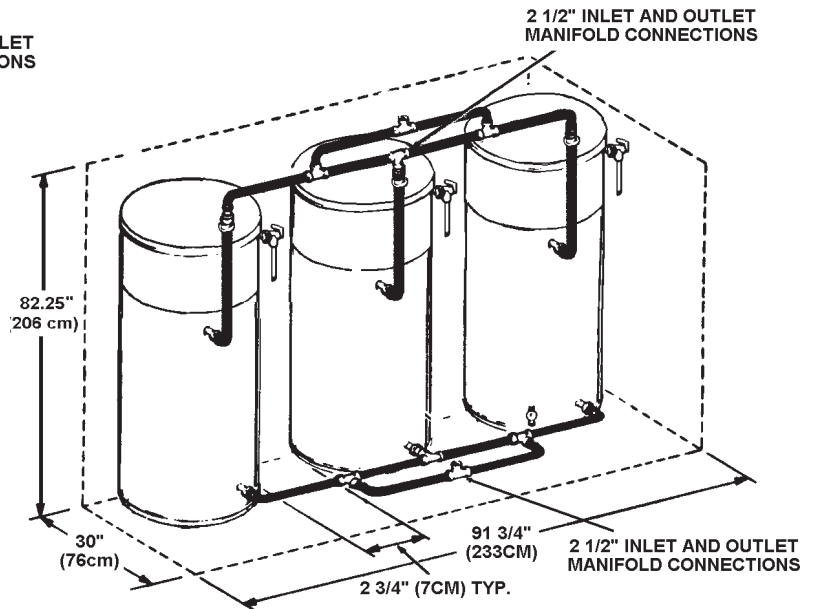

**FOUR UNIT MANIFOLD KIT
(PART NO. 195688)**

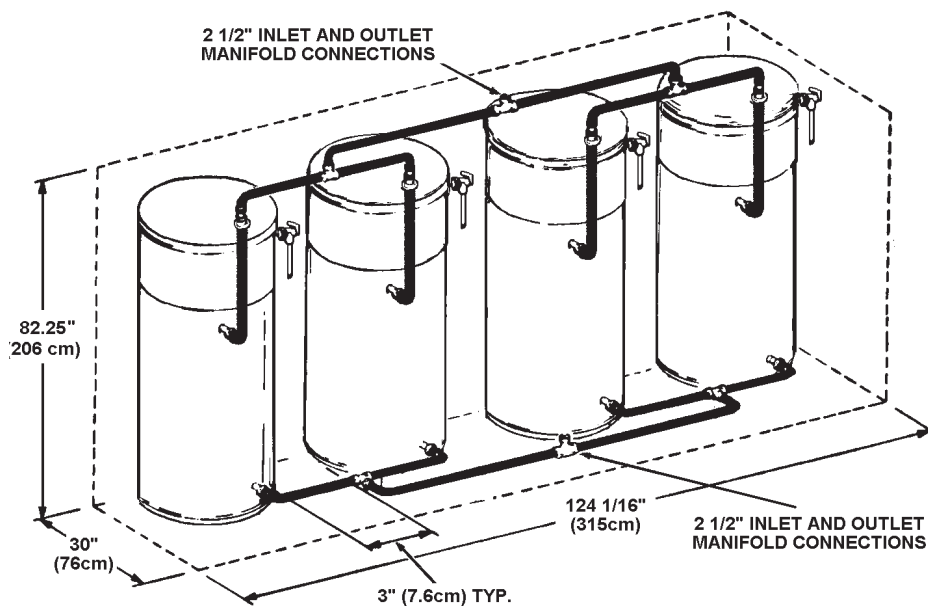

SEDIMENT REMOVAL

Waterborne impurities consist of the particles of soil and sand which settle out and form a layer of sediment on the bottom of the tank.

For convenience, sediment removal and lime scale removal should be performed at the same time.

LIME SCALE REMOVAL

The amount of calcium carbonate (lime) released from water is in direct proportion to water temperature and usage. The higher the water temperature or water usage, the more lime deposits are dropped out of the water. This is the lime scale which forms in pipes, heaters and on cooking utensils.

Lime accumulation not only reduces the life of the equipment but also reduces efficiency of the heater and increases fuel consumption.

The usage of water softening equipment greatly reduces the hardness of the water. However, this equipment does not always remove all of the hardness (lime). For this reason it is recommended that a regular schedule for deliming be maintained.

The depth of lime buildup should be measured periodically. Heaters will have about 3" (7.6 cm) of lime buildup when the level of lime has reached the bottom of the cleanout opening or about 1" (2.5 cm) of lime buildup if it has reached the drain valve opening. A schedule for deliming should be set up, based on the amount of time it would take for a 1" (2.5 cm) buildup of lime.

Example 1:

Initial inspection shows 1/2" (1.3 cm) of lime accumulation. Therefore, the heater can be delimed once a year.

Example 2:

Initial inspection shows 2" (5 cm) of lime accumulation. Therefore, the heater can be delimed every 3 months.

Sediment and lime scale removal may be accomplished through the cleanout opening furnished on the heater, see Figure 25. The heater must be drained, see DRAINING, before removing cleanout cover on tank.

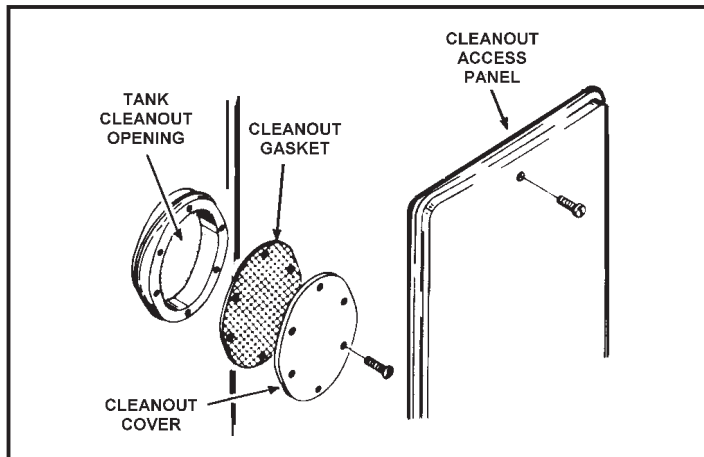

FIGURE 25

To dissolve and remove the more stubborn mineral deposits, A.O. Smith UN-LIME® Professional Delimer should be used.

A.O. Smith UN-LIME® Professional Delimer is an easy to handle patented food grade acid formulated specifically for lime scale removal from all types of water using equipment. Available in 1 gallon (3.8L) (part no. 4763) and 5 gallon (19L) (part no. 4813) sizes. Hydrochloric base acids are not recommended for use on glass-lined tanks.

A.O. Smith Form No. 4800, entitled "Why, When and How", describes tank cleaning methods and materials. UN-LIME and the booklet may be obtained through your A.O. Smith dealer or distributor.

The cleanout opening is shown in Figure 25. To clean heater through cleanout opening, proceed as follows:

1. Turn off water inlet valve, the heater electrical disconnect switch and open drain valve.
2. Remove outer cover plate from lower side of heater jacket.
3. Remove cover from cleanout opening.
4. Remove lime, scale or sediment using care not to damage the glass-lining.
5. Inspect cleanout plate gasket: If new gasket is required, replace with A.O. Smith part no. 99038.
6. Install cleanout plate. Be sure to draw plate up tight by tightening screws securely.
7. Close drain valve, open water inlet line and turn on the power burner electrical disconnect switch.
8. Check for water leakage.
9. Replace outer jacket cover plate.

ANODE INSPECTION AND REPLACEMENT

This water heater is equipped with multiple sacrificial anodes. Anodes protect the glass-lined tank from corrosion by sacrificing themselves through electrolysis. When the anode material is consumed, there is no more protection and corrosion of the tank accelerates.

Inspection of the anode every 6 to 12 months allows you to identify a spent anode and replace it. Replace the anode when its diameter is 3/8" (1 cm) of an inch, or annually whichever is first. Aggressive, very hot and softened water causes rapid consumption of the anode requiring frequent inspections. Anodes are available from your distributor or A.O. Smith.

REPLACEMENT PARTS

Replacement parts may be ordered through A.O. Smith dealers, authorized servicers or distributors. Refer to the Yellow Pages for where to call or contact A.O. Smith Water Heater Parts Fulfillment, 125 Southeast Parkway, Franklin, TN, 1-800-527-1953. When ordering parts be sure to state the quantity, part number as it appears on the product. Refer to the parts list for more information.

Model BPD 400 Limited Warranty

A. O. Smith Corporation, the warrantor, extends the following LIMITED WARRANTY to the owner of this water heater.

1. THE TANK

If the glass-lined tank in this water heater shall prove upon examination by the warrantor to have leaked due to natural corrosion from potable water therein, during the first THREE years after initial installation, the warrantor will supply a complete new A. O. Smith water heater of equivalent size and current model. Some government agencies are requiring energy efficient standards for water heaters. In the event regulations prohibit sale of a model of equivalent size and construction, A. O. Smith will provide a model which complies with the regulations of your area, in which case the consumer will be charged the difference in price between the like replacement and the energy efficient model required. The warranty on the replacement water heater will be limited to the unexpired term of the original warranty.

2. ALL OTHER PARTS

If within ONE year after initial installation of this water heater, any part or portion shall prove upon examination by the warrantor to be defective in material or workmanship, the warrantor will repair or replace such part or portion at its option.

3. CONDITIONS AND EXCEPTIONS

This warranty shall apply only when the water heater is installed in accordance with local plumbing and building codes, ordinances and regulations, the printed instructions provided with it and good industry practices. In addition, a temperature and pressure relief valve, certified by A.G.A./CGA and approved by the American Society of Mechanical Engineers, must have been installed.

a. This warranty shall apply only when the heater is used:

- (1) at temperatures not exceeding the maximum setting of its thermostat;
- (2) at water pressure not exceeding the working pressure shown on the water heater;
- (3) when operated free from the damaging effects of uncontrolled water hammer;
- (4) when filled with potable water, free to circulate at all times;
- (5) in a noncorrosive and non-contaminated atmosphere;
- (6) in its original installation location;
- (7) with factory approved anode(s) installed;
- (8) in the United States, its territories or possessions.
- (9) Fired at the factory rated input;
- (10) Owned by the original purchaser;
- (11) Sized in accordance with proper sizing techniques for commercial water heaters;
- (12) Bearing a rating plate which has not been altered, defaced or removed except as required by the warrantor;

b. Any accident to the water heater, any misuse, abuse (including freezing) or alteration of it, any operation of it in a modified form, any use of insulation blankets, or any attempt to repair tank leaks will void this warranty.

c. This warranty is void if a device acting as a backflow prevention device (check valves etc.) is installed in the cold water supply the heater is connected to, unless an effective method of controlling thermal expansion is also installed at the heater(s) and operational at all times.
The relief valve installed on the heater is not an acceptable method.

4. SERVICE AND REPAIR EXPENSES

Under the limited warranty the warrantor will provide only a replacement water heater or part thereof. The owner is responsible for all other costs. Such costs may include but are not limited to:

- a. Labor charges for service removal, repair or reinstallation of the water heater or any component part;
- b. Shipping, delivery, handling, and administrative charges for forwarding the new heater or replacement part from the nearest distributor and returning the claimed defective heater or part to such distributor.
- c. All cost necessary or incidental for any material and/or permits required for installation of the replacement heater or part.

5. LIMITATIONS ON IMPLIED WARRANTIES

Implied warranties, including the warranty of merchantability imposed on the sale of this heater under state or provincial law are limited to one (1) year duration for the heater or any of its parts. Some states and provinces do not allow limitation on how long an implied warranty lasts, so the above limitation may not apply to you.

6. CLAIM PROCEDURE

Any claim under the warranty should be initiated with the dealer who sold the heater, or with any other dealer handling the warrantor's products. If this is not practicable, the owner should contact:

U.S. Customers
A. O. Smith Water Products Company
500 Tennessee Waltz Parkway
Ashland City, TN 37015
Telephone: 1-800-323-2636

- a. The warrantor will only honor replacement with identical or similar water heater or parts thereof which are manufactured or distributed by the warrantor.
- b. Dealer replacements are made subject to in-warranty validation by warrantor.

7. DISCLAIMERS

NO OTHER EXPRESS WARRANTY HAS BEEN OR WILL BE MADE IN BEHALF OF THE WARRANTOR WITH RESPECT TO THE MERCHANTABILITY OF THE HEATER OR THE INSTALLATION, OPERATION, REPAIR OR REPLACEMENT OF THE HEATER. THE WARRANTOR SHALL NOT BE RESPONSIBLE FOR WATER DAMAGE, LOSS OF USE OF THE UNIT, INCONVENIENCE, LOSS OR DAMAGE TO PERSONAL PROPERTY OR OTHER CONSEQUENTIAL DAMAGE. THE WARRANTOR SHALL NOT BE LIABLE BY VIRTUE OF THIS WARRANTY OR OTHERWISE FOR DAMAGE TO ANY PERSONS OR PROPERTY, WHETHER DIRECT OR INDIRECT, AND WHETHER ARISING IN CONTRACT OR IN TORT.

- a. Some states or provinces do not allow the exclusion or limitation of the incidental or consequential damage, so the above limitations or exclusions may not apply to you.
- b. This warranty gives you specific legal rights, and you may also have other rights which vary from state to state or province to province.

Fill in the following for your own reference. Keep it. Registration is not a condition of warranty. The model and serial number are found on the heater's rating plate.

Model No. _____ Serial No. _____ Date Installed _____

Dealer's Name _____

A.O. Smith

Water Heaters

A.O. SMITH WATER PRODUCTS CO.
500 Tennessee Waltz Parkway, Ashland City, TN 37015
PHONE: 1-800-433-2545 • FAX: 1-800-433-2515
www.hotwater.com / email: parts@hotwater.com