

Series S

Panel meter 72x36mm



Model S40-F

AC frequency meter
Period meter
Simple counter

Panel meter to measure frequency from power networks (up to 500Vac and from 100mVac). Accepts also signals from mechanical contact and in general all 2 wire impulse and frequency signals, which do not need excitation voltage. Instrument can be configured to work as frequency meter, period meter and impulse counter. Special mode for low frequency signals. Reduced size 72x36mm. Reading with 4 digits. Provides pull-up and pull-down configurable resistors. Memory for maximum, minimum and cycles. Antirrebound filters, delays, 5 brightness levels, ... Universal AC and DC power modules and up to 2 modules for signal retransmission and control (relay outputs, analogue outputs, ...).

1. Meter S40-F

Panel meter 72x36mm for frequency signals

Panel meter for frequency signals from AC power lines (up to 500Vac and from 100mVac). Accepts also mechanical contacts and in general 2 wire impulse or frequency signals which do not need excitation voltage. The instrument can be configured to work in as frequency meter, period meter and impulse counter.

In frequency meter mode allows a direct reading (Hz) or scaled reading in engineering units. The scaled reading is configured through a configurable multiplier factor and a configurable divider factor. In period meter mode allows a reading proportional to the signal period.

In counter mode allows for a single impulse input and a reset control. The counter can be configured to work in UP or DOWN counting mode, it allows for PRESET configuration, alarm set and cycle counting.

The instrument can be configured to provide pull-up and pull-down resistances. The instrument does not provide excitation voltage to power the transducers.

Allows for up to 2 alarms with 1 or 2 setpoints each, with hysteresis and delays. Provides memory for maximum and minimum, password and brightness control.

Power options with universal AC and DC ranges, and space for three additional control and/or signal retransmission modules.

Instrument with reduced 72x36mm size. Resolution 4 digits with negative sign ("9999"/"-1999"). Standard IP54 front protection. Optional green led.

Connections via plug-in screw terminals and configuration via three front push-buttons. For application on industrial environments.

1.1 Order reference

Model	Power	Option1	Option2	Others
S40 - F	H	---	---	---
	-H (85-265 Vac/dc) -L (11-60 Vdc and 24/48 Vac)	-R1 (1 relay) -AO (Analogue Output) - (empty)	-R1 (1 relay) -AO (Analogue Output) - (empty)	-G (green led) - (empty)

Index

1. Meter S40-F	2	1.12.6 Sensor	8
1.1 Order reference	2	1.12.7 Alarms	9
1.2 Front View	3	1.12.8 Tools	9
1.3 Rear View	3	1.12.9 Menu OptX - Options.	9
1.4 Power Connections	3	1.13 Default factory configuration.	9
1.5 Input signal connections	3	1.14 Messages and errors	10
1.6 Function Frequency meter	4	1.15 Operating the menus	10
1.7 Function Counter	4	1.16 Accessing the instrument	10
1.8 Function Period meter	4	1.17 Warranty.	11
1.9 Mode "SLOW"	4	1.18 Installation precautions	11
1.10 Technical data	5	1.19 CE declaration of conformity	11
1.10 Technical data (cont.)	5	2. Output and control modules	12
1.11 Mechanical dimensions (mm)	5	2.1 Module R1	12
1.12 Configuration menu	6	2.2 Module AO	12
1.12 Configuration menu (cont.)	7	2.3 Modules R2, R4.	13
1.12.1 Function menu	8	3. More options and accessories	14
1.12.2 Decimal point.	8	3.1 Option G	14
1.12.3 Frequency meter configuration.	8		
1.12.4 Counter configuration	8		
1.12.5 Period meter configuration.	8		

1.2 Front View

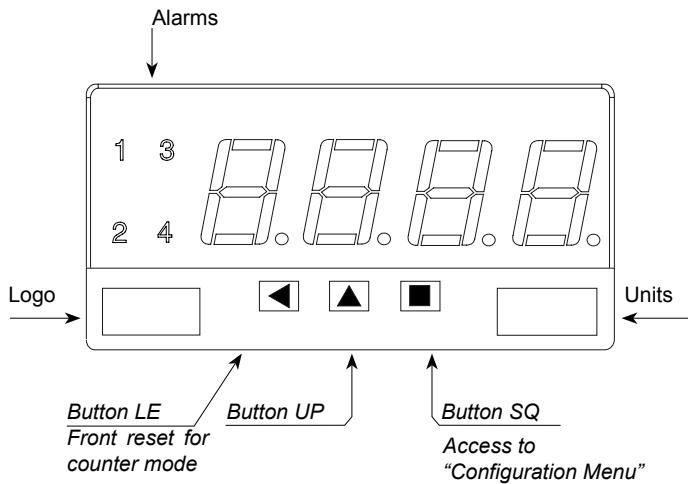

1.5 Input signal connections

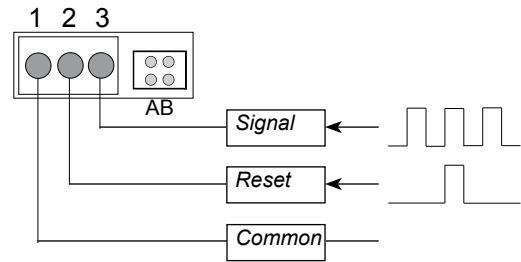

1.3 Rear View

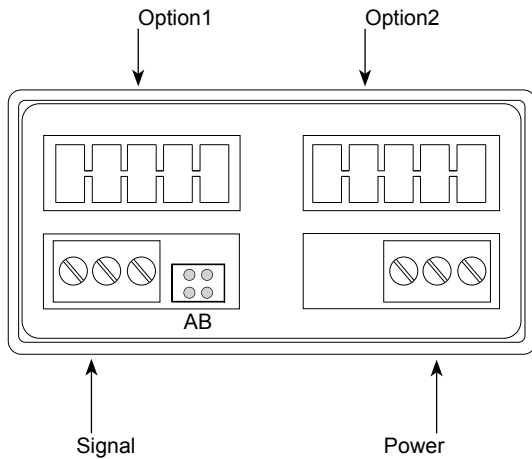

Close Jumpers	Signals	
A	Max. 30Vp (AC+DC)	
B	Max. 30V (DC component is filtered)	
---	Up to 500V (AC+DC)	

Table1 - Selection AB jumpers

To configure the type of sensor, use the parameters at the entry SNSR (sensor) at the configuration menu. Configuration at the SNSR entry allows for activation of the pulls (pull-up, pull-down, or without pull resistance), trigger level and the antirrebound filter.

The type of signals accepted by the instrument are :

- AC signals up to 500Vac
- AC signals from 100mVac
- Mechanical contact
- Pickup

The instrument does not provide excitation voltage to power the transducers. If your sensor needs excitation voltage, check references S40-C1 and S40-C2 designed to provide configurable excitation voltage.

The DC component of the input signal can be filtered selecting jumper B, and under the following restrictions : total signal AC+DC (peak) must not exceed 50V. The filtered AC component must not exceed 30V.

1.4 Power Connections

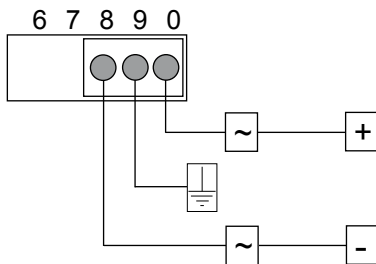

Earth connection - Although a terminal is offered for earth connection, the connection is optional. The instrument does not need this connection for correct functioning nor for compliance with the security regulations.

Fuse - To comply with security regulation 61010-1, add to the power line a protection fuse acting as disconnection element, easily accessible to the operator and identified as a protection device.

- Power "H" fuse 250mA time-lag
- Power "L" fuse 400mA time-lag

1.6 Function Frequency meter

Configured as frequency meter, the instrument counts the number of impulses received during a predefined time window. Frequency is calculated based on this information. Value shown on display can be scaled by configuring a multiplier (from 1 to 9999) and a divider (from 1 to 9999).

The instrument accepts signals from standard sensor, and also frequency from direct connection to AC power lines, up to 500Vac.

For applications with slow frequencies, the instrument provides a special mode named SLOW which provides the fastest response possible for slow frequencies. See section 1.9 for more information on this SLOW mode.

The maximum input frequency is 900 KHz and the minimum input frequency (with SLOW mode activated) is 0.001 Hz.

1.7 Function Counter

Configured as a counter, the instrument can be configured to act as UP counter or DOWN counter. Value shown on display can be scaled by configuring a multiplier (from 1 to 9999) and a divider (from 1 to 9999).

The PRESET value is configurable. The instrument provides a reset function at the rear terminal and a front key reset that can be enabled or disabled from the configuration menu. The rear reset can be configured to activate at high signal or low signal (trigger level at 2.5Vdc).

In case of overrange and underrange, the instrument can be configured to load a 0 on display, or to load the preset value on display, or configured to maintain the overrange/underrange state.

The instrument provides 2 alarms and each alarm can control a single relay (needs module R1 at slots Opt1, Opt2). When the alarm value is reached, the instrument can be configured to load a 0 on display, or to load the preset value on display, or to continue counting. The instrument can be configured for a delay time on the relay deactivation.

When the alarm is configured to return to 0 or to preset when setpoint is reached, the instrument may enter into a non-interrupted cycle, counting from a preset value to a alarm setpoint value and back to a preset value and so on. The instrument provides a cycle counter memory, accessible to the operator.

The instrument has memory retention in case of power lose. When power is recovered, the instrument recovers the last reading.

Maximum input frequency is 250 KHz.

For frequencies below 100Hz it is recommended to activate the antirrebound filter, to filter noises on the signal line.

1.8 Function Period meter

Configured as period meter, the instrument counts the number of impulses received during a predefined time window. Period is then calculated based on this information. Value shown on display can be scaled by configuring a multiplier (from 1 to 9999) and a divider (from 1 to 9999).

The instrument accepts signals from standard sensor, and also periods from direct connection to AC power lines, up to 500Vac.

For applications with long periods, the instrument provides a special mode named SLOW which provides the fastest response possible for slow frequencies. See section 1.9 for more information on this SLOW mode.

1.9 Mode "SLOW"

In functions Frequency meter and Period meter, the default working mode is based on defining a time window (parameter GATE) with a value between 0.5 and 16.0 seconds. During this time, the instrument counts the number of impulses received and calculates the frequency and the period. The value obtained is then multiplied and divided by the values at MULT and DIV parameters, and the display is updated.

In applications where frequencies are very slow, the time windows must be increased to the maximum, and this creates delays in the display refresh.

This instrument provides a dedicated working mode for low frequencies, named SLOW. In this mode the instrument calculates the time between impulses, and from this time it calculated the frequency and the period. With this working mode the refresh time is the fastest possible in slow applications.

To configure the SLOW mode, select the entry SLOW at the Frequency meter configuration menu or Period meter configuration menu. Once SLOW is activated, define the maximum time to wait between impulses (between 10 and 1000 seconds). If this maximum time is exceeded, the instrument considers that there are 0 impulses, and the frequency value is set to 0 and the period value is set to 0.

Activating the SLOW mode makes the value selected at the GATE parameter, unused.

1.10 Technical data

Digits	4
Type	7 segments, red
Height	14 mm
Display maximum	9999
Display minimum	-1999
Decimal point	selectable 8.8.8.8
Overrange	9999 flashing
Underrange	-1999 flashing

Signals accepted	impulses and frequencies
Connections	2 wires
Input impedance	2K4 when pull-up or pull-down resistances selected 470K 470pF when pulls not selected

Maximum input signal (see section 1.5)

Without AB jumpers	max. 500Vac
With jumper A	max. 30V peak (AC+DC)
With jumper B	max. 50V peak with max. 30V peak on the AC component

Maximum frequency

Frequency meter	900 KHz
Counter	250 KHz
Period meter	900 KHz

Minimum frequency

Frequency meter	1 mHz
Counter	[does not apply]
Period meter	1 mHz

Accuracy

Of the quartz oscillator	±0.05%
Thermal drift	20ppm/°C

Excitation voltage

does not provide

Refresh

Number of readings	1 / GATE in freq. and per. modes
Number of readings	15 / second in counter mode
Display refresh	15 / second

Power

Power "H"	85 to 265 Vac/dc
Power "L"	11 to 60 Vdc and 24/48Vac
Consumption	<4W
Isolation	3500Veff for power "H" 2000Veff for power "L" all levels tested for 60 seconds

Configuration

3 frontal push buttons
(rear jumper for coupling selection)

Functions available

Multiplier and divider	yes, configurable
Time gate	yes, configurable
Preset	yes, configurable

1.10 Technical data (cont.)

Pull resistances	yes, configurable
Trigger level	yes, configurable
Antirrebound filter	yes, configurable
Memory of maximum	yes
Memory of minimum	yes
Memory of cycles	yes
Memory of counter	yes, recovers data with power
Reset configurable	yes, front and/or rear reset rear reset at high or low level

Zeros to the left	yes, configurable
Password	yes, configurable
Brightness control	yes, 5 levels

Optional boards maximum 2

Mechanical

Mounting	panel
Connections	plug-in screw terminals
Weight	<150 grams
Housing materials	ABS, polycarbonate
Front size	72x36mm
Panel cut-out	69x32.5mm
Deep from panel	98mm (including terminal)

Front protection IP54

Temperature Operation	0 to 50°C
Temperature Storage	-20 to +70°C
Warm-up	15 minutes

1.11 Mechanical dimensions (mm)

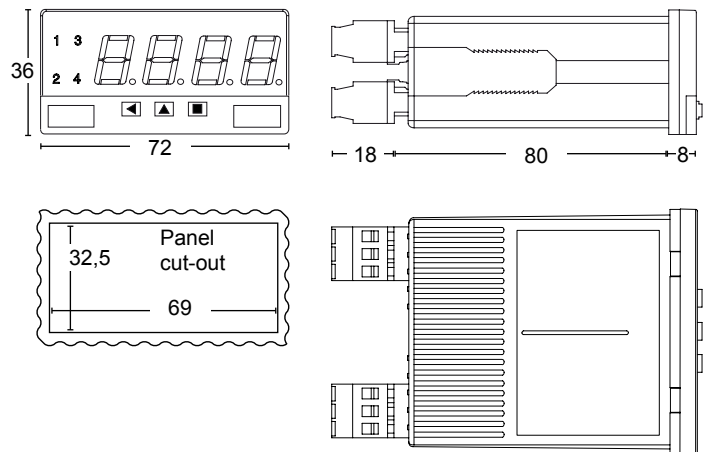

1.12 Configuration menu

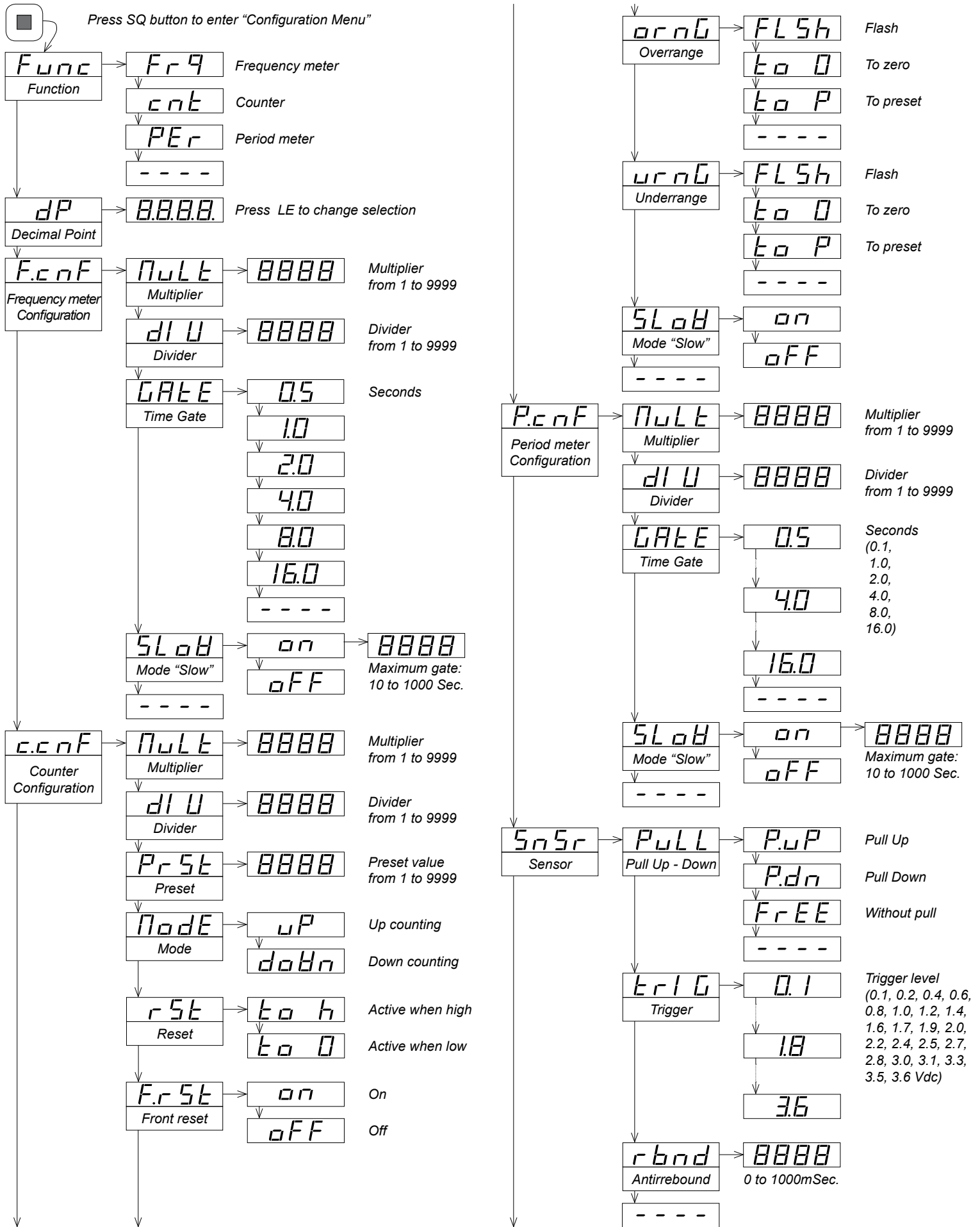

1.12 Configuration menu (cont.)

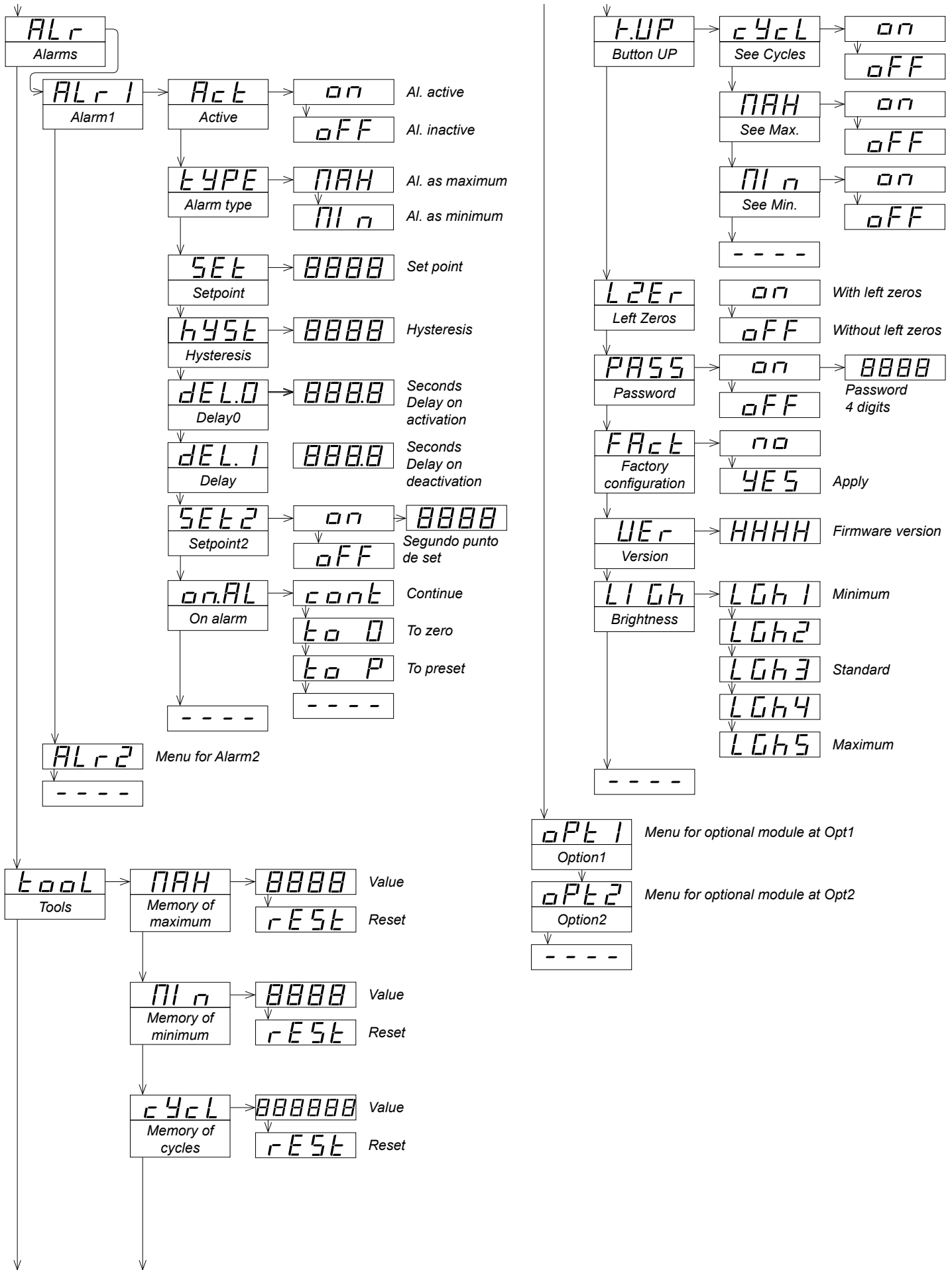

1.12.1 Function menu

The "FUNC" menu allows to select the active function of the instrument. Select between Frequency meter, Counter and Period meter.

1.12.2 Decimal point

Select the position for the decimal point. Modify with the LE button and validate with the SQ button.

1.12.3 Frequency meter configuration

The "F.CNF" menu is visible only if the Frequency meter mode is selected. The frequency value is calculated based on the number of impulses received during the time window defined at the GATE parameter ($\text{freq} = \text{impulses} / \text{GATE}$). The frequency value obtained is multiplied by the MULT parameter, divided by the DIV parameter, and the result is updated on display. Value on display is updated every X seconds (value defined at the GATE parameter).

Multiplier (MULT) - Value from 1 to 9999. Multiplier factor to be applied to the calculated frequency value.

Divider (DIV) - Value from 1 to 9999. Divider factor to be applied to the calculated frequency value.

Time Gate (GATE) - Selectable to 0.5, 1.0, 2.0, 4.0, 8.0 and 16.0 seconds. Impulses are counted for the duration of this time window. Obtained frequency value is multiplied by MULT and divided by DIV and updated on display.

Mode "Slow" (SLOW) - Selectable to active (ON) or inactive (OFF). If active, indicate the value in seconds for the maximum time window. Value from 10 to 1000 seconds. See section 1.9. Mode SLOW disables the value selected at GATE.

1.12.4 Counter configuration

The "C.CNF" menu is visible only if the Counter mode is selected. Impulses received are internally counted, multiplied by the MULT parameter, divided by the DIV parameter, and the result is updated on display. Value on display is updated 15 times / second.

Multiplier (MULT) - Value from 1 to 9999. Multiplier factor to be applied to the total number of impulses counted.

Divider (DIV) - Value from 1 to 9999. Divider factor to be applied to the total number of impulses counted.

Preset (PRST) - Value from 9999 to -1999. Preset value. Preset value is loaded on display when the reset function is activated.

Mode (MODE) - Value UP or DOWN. Select UP for up counter (received impulses add). Select DOWN for down counter (impulses received subtract).

Front reset (F.RST) - Value ON or OFF. Select ON to activate the front reset function when pressing front key LE. Select OFF to deactivate the front reset function (key LE has no assigned function).

Overrange (ORNG) - Function to activate in case of display

overrange (display higher than 9999). Select "flash" (FLSH) to maintain the reading at 9999 in flash mode. Select "to zero" (to_0) to jump to 0 display when overrange. Select "to preset" (to_p) to jump to preset value when overrange.

Underrange (URNG) - Function to activate in case of display underrange (display lower than -1999). See previous description "Overrange".

Mode "Slow" (SLOW) - Selectable to active (ON) or inactive (OFF). Activate for frequencies lower than 100Hz. SLOW mode is automatically enabled when Antirrebound Filter is different than 0. See section 1.12.6..

1.12.5 Period meter configuration

The "P.CNF" menu is visible only if the Period meter mode is selected. The period value is calculated based on the number of impulses received during the time window defined at the GATE parameter ($\text{period} = \text{GATE} / \text{impulses}$). The period value obtained is multiplied by the MULT parameter, divided by the DIV parameter, and the result is updated on display. Value on display is updated every X seconds (value defined at the GATE parameter).

Multiplier (MULT) - Value from 1 to 9999. Multiplier factor to be applied to the calculated period value.

Divider (DIV) - Value from 1 to 9999. Divider factor to be applied to the calculated period value.

Time Gate (GATE) - Selectable to 0.5, 1.0, 2.0, 4.0, 8.0 and 16.0 seconds. Impulses are counted for the duration of this time window. Obtained period value is multiplied by MULT and divided by DIV and updated on display.

Mode "Slow" (SLOW) - Selectable to active (ON) or inactive (OFF). If active, indicate the value in seconds for the maximum time window. Value from 10 to 1000 seconds. See section 1.9. Mode SLOW disables the value selected at GATE.

1.12.6 Sensor

Menu SNSR configures the instrument for the type of signal it will receive.

Pulls (PULL) - Configures resistors for Pull-Up (P.UP), Pull-Down (P.DN) or none (FREE). Trigger level is automatically set to 2.5Vdc when PULLS are selected, or 0.1Vdc when FREE is selected.

Trigger (TRIG) - Value from 0.1 to 3.6. Value in Vdc. Pre-defined values for the trigger level. The signal is considered to be a logical '1' when the signal value is higher than the trigger value. The signal is considered to be a logical '0' when the signal value is lower than the trigger value. In case of signals with DC component, see section 1.5 to configure DC filter.

Antirrebound (RBND) - Antirrebound filter. Selectable from 0 to 1000 mSeconds. For mechanical contact start at 10mSeconds. When an impulse is received, the filter activates and no impulses are received for the duration of the filter value. When the filter time is over, next impulse is received and filter activates again.

1.12.7 Alarms

The instrument can manage up to 2 alarms. These alarms control optional relays R1 (see section 2.1) which can be installed at slots Opt1 and Opt2. More alarms can be achieved by installing special control modules R2 and R4. Configuration menus for special modules are not listed in this document.

Active (ACT) - Value "ON/OFF". Defines if the instrument has to manage this alarm or not. Select "OFF" for alarm not managed.

Type (TYPE) - Value "MAX/MIN". Defines the behavior of the alarm as maximum or minimum alarm. The alarms configured as maximum are activated when the display value is equal or higher than the setpoint. The alarms configured as maximum are deactivated when the display is lower than the setpoint. The alarms configured as minimum have the inverse behavior.

Setpoint (SET) - Value from "9999" to "-1999". Alarm set point.

Hysteresis (HYST) - Value from "0" to "9999". Points of hysteresis. The hysteresis applies on the deactivation of the alarm.

Delay (DEL.0) - Value from "0.0" to "99.9" seconds. Activation delay for relays R1. Relays and front led are activated X seconds after alarm activation.

Delay (DEL.1) - Value from "0.0" to "99.9" seconds. Deactivation delay for relays R1. Relays and front led are deactivated X seconds after alarm activation.

Setpoint2 (SET2) - Value from "-1999" to "9999". Second setpoint. The second setpoint allows for the creation of activation windows. If the alarm is configured as maximum with setpoint 1000 and setpoint2 is configured at 1500, the alarm will be activated between 1000 and 1500 and the alarm will be deactivated when display is <1000 and >1500. Setpoint2 is affected on the same way as the setpoint with hysteresis and delays.

On Alarm (ON.AL) - Use only in counter mode. Behavior when the display has reached setpoint value. Select "cont" (CONT) to continue counting. Select "to zero" (to_0) to reset reading to 0 value. Select "to preset" (to_p) to reset reading to preset value. Selecting "to_0" or "to_p", configures "DEL.1" to 1 second, by default.

1.12.8 Tools

Maximum (MAX) - Maximum memory value and maximum memory reset function.

Minimum (MIN) - Minimum memory value and minimum memory reset function.

Cycles (CYCL) - Cycle memory value and cycle memory reset function.

Button UP (K.UP) - Information accessible when pressing key UP. Select one, several, all or none of the parameters indicated to visualize their value using the UP key. Parameters available are : number of cycles (CYCL), memory of

maximum (MAX) and memory of minimum (MIN).

Left Zero (LZER) - Value "On/Off". Select "On" to visualize zeros to the left.

Password (PASS) - Select a 4 digit number to act as password. This password will be requested when entering the Configuration Menu. To deactivate the password select "Off".

Factory Settings (FACT) - Factory default configuration. Select "YES" to activate the factory default configuration.

Version (VER) - Firmware version installed.

Light (LIGH) - Brightness. Select between 5 predefined levels of brightness.

1.12.9 Menu OptX - Options

Menu options OPT1, OPT2 and OPT3 give access to the configuration menus of the options installed at slots Opt1, Opt2 and Opt3. This menu depends on the installed option. If there is no option installed the instrument shows "NONE". Control modules R1 are controlled from the standard alarm menu (see section 1.12.7).

1.13 Default factory configuration

Function	frequency meter
Decimal point	XX.XX
Multiplier	x100
Divider	/1
Gate	0.5 seconds
Slow	On, 1 second
Sensor	
Pull resistances	none (free)
Trigger	0.1Vdc
Antirrebound filter	0 mSeconds
Tools	
Maximum	-1999
Minimum	9999
Cycles	0
Key UP	max., min.
Left zeroes	off
Password	off
Brightness	3
Alarms 1,2 and 3	
Active	off (inactive)
Type	maximum
Setpoint	1000
Hysteresis	0 counts
Activation delay	0.0 seconds
Deactivation delay	0.0 seconds
Setpoint2	off
On Alarm	continue
Default counter configuration	
Multiplier	x1
Divider	/1
Preset	0
Mode	up counter
Reset	to 0V
Front reset	on
Overrange	flash
Underrange	flash

1.14 Messages and errors

The instrument can display the following messages and errors.

“Err.1” Password entered is not correct.

“Err.2” The instrument has detected an installed option but was unable to communicate.

“9999” + flash. The display is in overrange (real display should be higher than 9999 and can not be displayed).

“-1999” + flash. The display is in underrange (real display should be lower than -1999 and can not be displayed).

“E.101” Option is installed but the type can not be recognized.

1.15 Operating the menus

The instrument has two menus accessible to the user :

“Configuration Menu” (key SQ)

“Information Menu” (key UP)

The *“Configuration Menu”* allows to change the configuration of the instrument. Access to the *“Configuration Menu”* can be password protected with the function *“PASSWORD”*. During operation with the *“Configuration Menu”* the alarms are kept *“on-hold”*. When leaving the *“Configuration Menu”* the instrument performs a restart, and new configuration is applied. On restart of the instrument, also the control output modules are restarted (relays, analogue outputs, ...).

The *“Information Menu”* is for information only, and it does not accept changes on the displayed information. To enter the *“Information Menu”* press the *“UP”* button. It is not affected by the *“PASSWORD”* function. Leaving the *“Information Menu”* returns to the measuring state of the instrument, without restart of the unit.

Rollback - After 30 seconds without interaction from the operator, the instrument leaves the menu and returns to the previous working mode. In case of configuration menu, all changes are discarded.

Button SQ - Selects the menu entry currently displayed. When entering a numeric value (for example a setpoint value) validates the value on display.

Button UP - Moves vertically on the menu entries. When entering a numeric value (for example a setpoint value) modifies the current digit by increasing its value up from 0 to 1, 2, 3, 4, 5, 6, 7, 8, 9.

Button LE - Leaves the current menu. Pressing LE several times will leave all menus. When leaving all menus in the configuration menu, changes will be saved. When entering a numeric value (for example a setpoint value) it moves from one digit to the next. Each digit value can then be modified with the UP button.

1.16 Accessing the instrument

You may need to access the inside of the instrument to insert additional modules. Use a flat screwdriver to unlock the upper clips marked with “A”. Then unlock the lower clips marked with “B” and move out the front filter. Let the inside of the instrument slide out of the housing.

To reinsert the instrument make sure that all modules are correctly connected to the pins on the display module. Place all the set into the housing, assuring that the modules correctly fit into the internal guiding slides of the housing. Once introduced, place again the front filter by clipping first the upper clips “A” and then the lower clips “B”.

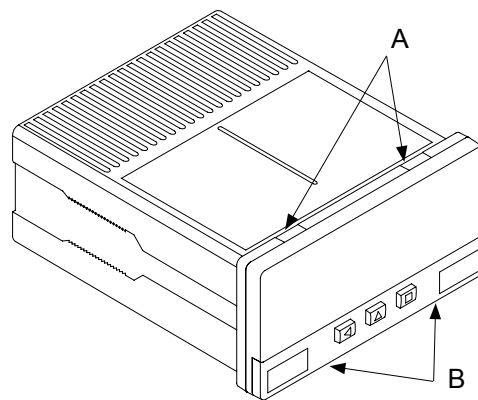

Risk of electric shock. Removing the front cover will grant access to the internal circuits. Disconnect the input signal to prevent electric shock to the operator. Operation must be performed by qualified personnel only.

1.17 Warranty

All instruments are warranted against all manufacturing defects for a period of 24 MONTHS from the shipment date. This warranty does not apply in case of misuse, accident or manipulation by non-authorized personnel. In case of malfunction get in contact with your local provider to arrange for repair. Within the warranty period and after examination by the manufacturer, the unit will be repaired or substituted when found to be defective. The scope of this warranty is limited to the repair cost of the instrument, not being the manufacturer eligible for responsibility on additional damages or costs. .

1.18 Installation precautions



Risk of electrical shock. Instrument terminals can be connected to dangerous voltage.



Instrument protected with double isolation. No earth connection required.



Instrument is in conformity with CE rules and regulations. See "CE Declaration of Conformity" further in this document.

This instrument has been designed and verified according to the 61010-1 CE security regulation, and is designed for applications on industrial environments. See the "CE Declaration of Conformity" further in this document for information on the category of measure and the degree of pollution levels that apply.

Installation of this instrument must be performed by qualified personnel only. This manual contains the appropriate information for the installation. Using the instrument in ways not specified by the manufacturer may lead to a reduction on the specified protection level. Disconnect the instrument from power before starting any maintenance and / or installation action.

The instrument does not have a general switch and will start operation as soon as power is connected. The instrument does not have protection fuse, the fuse must be added during installation.

The instrument is designed to be panel mounted. An appropriate ventilation of the instrument must be assured. Do not expose the instrument to excess of humidity. Maintain clean by using a humid rag and do NOT use abrasive products such as alcohols, solvents, etc.

General recommendations for electrical installations apply, and for proper functionality we recommend : if possible, install the instrument far from electrical noise or magnetic field generators such as power relays, electrical motors, speed variators, ... If possible, do not install along the same conduits power cables (power, motor controllers, electrovalves, ...) together with signal and/or control cables.

Before proceeding to the power connection, verify that the voltage level available matches the power levels indicated in the label on the instrument.

In case of fire, disconnect the instrument from the power line, fire alarm according to local rules, disconnect the air conditioning, attack fire with carbonic snow, never with water.

1.19 CE declaration of conformity

Manufacturer FEMA ELECTRÓNICA, S.A.
Altimira 14 - Pol. Ind. Santiga
E08210 - Barberà del Vallès
BARCELONA - SPAIN
www.fema.es - info@fema.es

Products S40-F

The manufacturer declares that the instruments indicated comply with the directives and rules indicated below.

Electromagnetic compatibility directive 2004/108/CE
Low voltage directive 2006/95/CE

Security rules EN-61010-1

Instrument Fixed
Permanently connected
Pollution degree 1 and 2 (without condensation)
Isolation Double
Category CAT-II

Electromagnetic compatibility rules EN-61326-1

EM environment Industrial

Immunity levels

EN-61000-4-2	By contact ± 4 KV By air ± 8 KV	Criteria B Criteria B
EN-61000-4-3		Criteria A
EN-61000-4-4	On AC power lines : ± 2 KV On DC power lines : ± 2 KV On signal lines : ± 1 KV	Criteria B Criteria B Criteria B
EN-61000-4-5	Between AC power lines ± 1 KV Between AC power lines and earth ± 2 KV Between DC power lines ± 1 KV Between DC power lines and earth ± 2 KV Between signal lines and earth ± 1 KV	Criteria B Criteria B Criteria B Criteria B Criteria B
EN-61000-4-6		Criteria A
EN-61000-4-8	30 A/m at 50/60 Hz	Criteria A
EN-61000-4-11	0 % 1 cycle 40 % 10 cycles 70 % 25 cycles 0 % 250 cycles	Criteria A Criteria A Criteria B Criteria B

Emission levels

CISPR 11	Instrument Class A, Group 1	Criteria A
----------	-----------------------------	------------

Barberà del Vallès October 2014
Daniel Juncà - Quality Manager



According to directive 2012/19/EU, electronic equipment must be recycled in a selective and controlled way at the end of its useful life.

2. Output and control modules

2.1 Module R1

Module with 1 relay. Up to a maximum of two R1 modules can be installed in one S Series panel meter. For more relay output needs, check special modules R2 and R4. For more information see document *2657_S40_OPTIONAL_MODULES* at www.fema.es

Relay type	3 contacts (Common, NC, NO)
Maximum current	8A (resistive load)
Voltage	250 Vac continuously
Installable at	Option1 and/or Option2

2.2 Module AO

Module with 1 analogue output. Configurable 4/20mA or 0/10Vdc. Output signal proportional to the reading. Scaling through the frontal keypad. Up to a maximum of two AO modules can be installed in one S Series panel meter. For more information see document *2657_S40_OPTIONAL_MODULES* at www.fema.es

Output	4/20mA, 0/10Vdc selectable
Accuracy	0.1% FS
Isolated	yes, 1000Vdc
Thermal drift	50 ppm/°C for Vdc 60 ppm/°C for mA
Installable at	Option1 and/or Option2

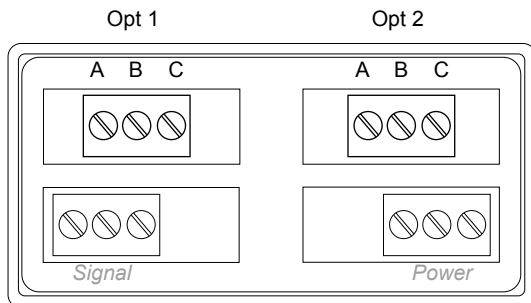

Terminal A	Common
Terminal B	NO - Normally Open
Terminal C	NC - Normally Closed

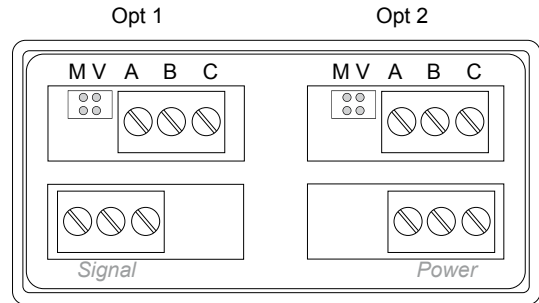

Jumper M	mode mA
Jumper V	mode Vdc
Terminal A	Vexc (+13.8Vdc @25mA)
Terminal B	Signal output (mA or Vdc)
Terminal C	GND

2.3 Modules R2, R4

Special modules with 2 and 4 relays. Use special modules R2 or R4 when standard R1 modules do not provide required functionality for your application. Only one special module R2 or R4 can be installed in an S Series panel meter. Special modules R2 and R4 are not compatible with R1 modules.

Configuration is done through the OPTx entry of the configuration menu. Functionality for R2 and R4 modules differs from standard R1 modules. For more information see document 2657_S40_OPTIONAL_MODULES at www.fema.es

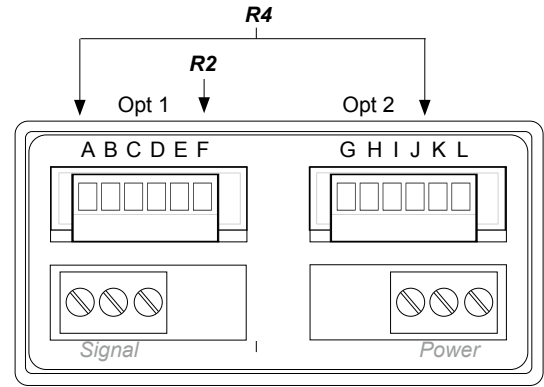

Number of relays	2, or 4
Relay type	3 contacts (Common, NO, NC)
Maximum current	6A (resistive load) (each relay)
Voltage*	250 Vac continuously
Installable at slot	Opt.1.
	R2 fills OPT1
	R4 fills OPT1 and OPT2
Terminal	Plug-in screw terminals pitch 3.81mm

* Terminals approved for 300V (according to UL1059, groups B and D) and 160V (according to VDE in CAT-III and pollution degree 3).

Terminal A	Relay1 Common
Terminal B	Relay1 NO - Normally Open
Terminal C	Relay1 NC - Normally Closed
Terminal D	Relay2 Common
Terminal E	Relay2 NO - Normally Open
Terminal F	Relay2 NC - Normally Closed
Terminal G	Relay3 Común
Terminal H	Relay3 NO - Normally Open
Terminal I	Relay3 NC - Normally Closed
Terminal J	Relay4 Common
Terminal K	Relay4 NO - Normally Open
Terminal L	Relay4 NC - Normally Closed

3. More options and accessories

3.1 Option G

Green led option.



THIS PAGE BLANK

other products



Panel Meters
Standard 96x48mm



Panel Meters
Small 72x36mm



Panel Meters
Miniature 48x24mm



Large Displays
60&100mm digit



Signal Converters
& Isolators



Bar Meters

www.fema.es

ELECTRONIC INSTRUMENTATION FOR INDUSTRY

FEMA ELECTRÓNICA, S.A.
Altimira 14 - Pol. Ind. Santiga
E08210 Barberà del Vallès
BARCELONA - SPAIN

Tel. (+34) 93.729.6004 - www.fema.es
Fax (+34) 93.729.6003 - info@fema.es