

**XZ050**

**ACQIRIS CC121 COMPACTPCI CRATE**

**USER MANUAL**

May 2005

The information in this document is subject to change without notice and may not be construed as in any way as a commitment by Acqiris. While Acqiris makes every effort to ensure the accuracy and contents of the document it assumes no responsibility for any errors that may appear.

All software described in the document is furnished under license. The software may only be used and copied in accordance with the terms of license. Instrumentation firmware is thoroughly tested and thought to be functional but it is supplied “as is” with no warranty for specified performance. No responsibility is assumed for the use or the reliability of software, firmware or any equipment that is not supplied by Acqiris SA or its affiliated companies.

Any versions of this manual which are supplied with a purchased product will be replaced at your request with the latest revision in electronic format. At Acqiris we appreciate and encourage customer input. If you have a suggestion related to the content of this manual or the presentation of information, please contact your local Acqiris representative or Acqiris Technical Support ([support@acqiris.com](mailto:support@acqiris.com)) or come visit our web site at <http://www.acqiris.com>.

Trademarks: product and company names listed are trademarks or trade names of their respective companies.

**Acqiris Headquarters :**

**Acqiris SA  
18, chemin des Aulx  
CH-1228 Plan-les-Ouates  
Geneva  
Switzerland**

**Tel: +41 22 884 33 90**

**Fax: +41 22 884 33 99**

**Acqiris USA :**

**Acqiris LLC  
234 Cromwell Hill Road  
P.O. Box 2203  
Monroe, NY 10950-1430  
USA**

**Tel: 845 782 6544**

**Fax: 845 782 4745**

**Acqiris Asia-Pacific :**

**Acqiris Pty Ltd  
Suite 7, Level 1  
407 Canterbury Road  
P.O. Box 13  
Surrey Hills 3127  
Australia**

**Tel: +61 3 9888 4586**

**Fax: +61 2 9849 0861**

© Copyright May 2005, Acqiris SA. All rights reserved.

## CONTENTS

<b>1.</b>	<b>OUT OF THE BOX.....</b>	<b>4</b>
1.1.	Message to the User .....	4
1.2.	Before Using Your Crate .....	4
1.3.	Organization of This Manual .....	4
1.4.	Conventions Used in This Manual .....	4
1.5.	Disclaimer and Safety .....	5
1.6.	Warning Regarding Medical Use.....	5
1.7.	Packaging and Handling .....	5
1.8.	Optional Equipment .....	6
1.8.1.	CompactPCI 6U to 3U Slot Adapter .....	6
1.8.2.	Filler Plug-in .....	6
1.9.	Warranty .....	6
1.10.	Warranty and Repair Return Procedure .....	7
1.11.	Maintenance .....	7
1.12.	Cleaning .....	7
1.13.	Disposal and Recycling.....	7
<b>2.</b>	<b>INSTALLATION .....</b>	<b>8</b>
2.1.	Configuration .....	8
2.2.	Site Considerations .....	9
2.3.	AC Mains Power .....	9
2.3.1.	Connecting to AC Mains Power.....	9
2.3.2.	Fuses.....	9
2.4.	Installing CompactPCI Modules .....	9
2.4.1.	Installing 6U modules .....	10
2.4.2.	Installing 3U modules .....	10
2.4.3.	Installing Filler Plug-in.....	10
<b>3.</b>	<b>SPECIFICATIONS .....</b>	<b>11</b>
3.1.	Main Features.....	11
3.2.	Power Supply .....	11
3.2.1.	AC Input Specifications .....	11
3.2.2.	DC Outputs Specifications .....	12
3.3.	Slot Specifications.....	12
3.4.	Backplane.....	13
3.4.1.	Backplane Specifications.....	13
3.4.2.	Power Supply Status.....	14
3.4.3.	Connector Pinouts .....	15
3.5.	Environmental.....	16
3.5.1.	Environmental Specifications.....	16
3.5.2.	Safety.....	16
3.5.3.	EMC Emission .....	16
3.5.4.	EMC Immunity.....	16
3.6.	Mechanical.....	17
3.6.1.	Mechanical Specifications .....	17
3.6.2.	Dimensions.....	17
<b>4.</b>	<b>APPENDICES .....</b>	<b>18</b>
4.1.	XC100 6U to 3U Slot Adapter .....	18
4.2.	XC200 6U Filler Plug-in.....	19

## 1. OUT OF THE BOX

### 1.1. Message to the User

Congratulations on having purchased an Acqiris product. CC121 crates use the highest quality components and high output power supplies in order to maximize system performance and reliability. These universally applicable CompactPCI crates are carefully designed to yield high performance test systems for bench, lab and manufacturing test applications.

### 1.2. Before Using Your Crate

This User Manual describes the features of the CC121 crate and contains information for your safety, about configuring the crate, installing the modules, and operating the system.



**CAUTION** *The AC power input line is fully protected by two fuses the value of which depends on the AC input voltage. For safety reasons, the user must check that those values comply with the input voltage used before connecting the crate to the AC mains power. For further information, please refer to the paragraph 2.3.2. Fuses.*

### 1.3. Organization of This Manual

This manual is organized as follows :

- Chapter 1 **OUT OF THE BOX**, gives information you must know prior to using CC121 crates, lists the contents of the box, lists optional equipment you can order from Acqiris, and describes the warranty and repair return procedure.
- Chapter 2 **INSTALLATION**, describes how to prepare and operate your CC121 crate.
- Chapter 3 **SPECIFICATIONS**, gives complete technical specifications of your CC121 crate.
- Chapter 4 **APPENDICES**, gives specifications and assembly instructions supplied with the optional equipments.

### 1.4. Conventions Used in This Manual

The following conventions are used in this manual :



- This icon to the left of text warns that an important point must be observed.
- WARNING** Denotes a warning, which advises you of precautions to take to avoid being electrically shocked.
- CAUTION** Denotes a caution, which advises you of precautions to take to avoid electrical, mechanical, or operational damages.
- NOTE** Denotes a note, which alerts you to important information.
- Italic* Italic text denotes a warning, caution, or note.
- Bold Italic*** Bold italicized text is used to emphasize an important point in the text or a note

## 1.5. Disclaimer and Safety



**WARNING :** *The CC121 crate contains voltage hazardous to human life and safety, and is capable of inflicting personal injury. For your safety, before undertaking any troubleshooting or maintenance procedure, read carefully the WARNING and CAUTION notices.*

**Crate Grounding :** The CC121 crate requires a connection from the premises wire safety ground to the CC121 chassis ground to minimize shock hazard. This crate is designed with a three-position IEC320 C14 plug that connects the earth safety ground line to the chassis ground. ***A power cord with protective safety ground conductor must be used.*** The earth safety ground line must be always connected during use of this equipment. To minimize shock hazard, make sure your electrical power outlet has an appropriate earth safety ground that is connected whenever you power up the crate.

**Live Circuits :** Operating personnel must not remove protective covers when operating or servicing the CC121 crate. Adjustments and service to internal components must be undertaken by qualified personnel. During service of this product, the mains connector to the premise wiring must be disconnected. Dangerous voltages may be present under certain conditions, use extreme caution.

**Explosive Atmosphere :** Do not operate the crate in conditions where flammable gases are present. Under such conditions this crate is unsafe and may ignite the gases or gas fumes.

**Part Replacement :** Only service this crate with parts that are exact replacements, both electrically and mechanically. Installation of parts that are not exact replacements may cause harm to personnel operating the crate. Furthermore, damage or fire may occur if replacement parts are unsuitable.

**Modification :** Do not modify any part of the crate from its original condition. Unsuitable modifications may result in safety hazards.

## 1.6. Warning Regarding Medical Use

The CC121 crates are not designed with components and testing intended to ensure a level of reliability suitable for use in treatment and diagnosis of humans. Applications of these crates involving medical or clinical treatment can create a potential for accidental injury caused by product failure, or by errors on the part of the user. These crates are **not** intended to be a substitute for any form of established process or equipment used to monitor or safeguard human health and safety in medical treatment.



**WARNING :** The modules discussed in this manual have not been designed for making direct measurements on the human body. Users who connect an Acqiris module to a human body do so at their own risk.

## 1.7. Packaging and Handling

After carefully unpacking all items, inspect the shipping box and the crate for damage. Check for visible damage to the metal work. Check to make sure that all hardware and the switch are undamaged. Inspect the inner chassis for any possible damage, debris, or detached components. If damage appears to have been caused in shipment, file a claim with the carrier. Also check that all the components received match those listed on the enclosed packing list. Acqiris cannot accept responsibility for missing items unless notified promptly of any discrepancies. If any items are found to be missing or are received in a damaged condition please contact the Customer Support Center or your local supplier immediately.

Verify that you have received the following items with your CC121 crate :

- Power cord

Power Cord	Rating	Reference Standards
Universal Europa	250V/10A	CEE7 sht/IEC320 C13
North America	125V/15A	NEMA 5-15/IEC320 C13
United Kingdom	250V/10A	BS1363A/IEC320 C13
Italy	250V/10A	CIE 23-16/IEC320 C13
Switzerland	250V/10A	SEV1011/IEC320 C13

- CC121 CompactPCI Crate User Manual.
- Declaration of Conformity.
- A compact disc that includes
  - 7 product user manuals in electronic form (Family of 8-bit Digitizers, Family of 10-bit Digitizers, Family of 12-bit Digitizers, Family of Averagers, Family of Analyzers, CC10X Family of CompactPCI Crates and CC121 CompactPCI Crate),
  - 1 Programmer's Guide and 1 Programmer's Reference Manual in electronic form,
  - device drivers with sample software for different operating systems, environments and languages,
  - the AcqirisLive application, a demonstration program for our digitizer and averager products,
  - the AP\_SSRDemo application, a demonstration program for the Acqiris AP235/AP240 Analyzers,
  - the APx01Demo application, a demonstration program for the Acqiris AP101/AP201 Analyzers,
  - product data sheets,
  - other promotional literature
  - full installation procedures for use with Microsoft Windows, National Instruments LabVIEW RT, Phar Lap ETS, Wind River VxWorks, and Linux software.
- Optional equipment. See the enclosed packing list.

## 1.8. Optional Equipment

### 1.8.1. CompactPCI 6U to 3U Slot Adapter

The optional *XC100 Slot Adapter* is specially designed for use with Acqiris CompactPCI crates. This CompactPCI slot adapter allows the use of 3U modules in any vacant 6U slots. The XC100 assures proper mechanical alignment when inserting a 3U module and protects the crate's backplane connectors from damage. In addition, the XC100 meets the IEEE 1011.10 standard and provides the function of a filler panel to completely close the half vacant slot. This function is essential to guarantee EMC performance and appropriate cooling.

### 1.8.2. Filler Plug-in

An optional *XC200 Filler Plug-in* is available from Acqiris. This 6U CompactPCI plug-in (width 1 slot) meets the IEEE 1011.10 standard and implements the function of a filler panel that completely closes the front of the unused slots and reduces the cross-flow air circulation. This function is essential to guarantee EMC performance and appropriate cooling.

## 1.9. Warranty

Acqiris endeavors to provide leading edge technology that includes the latest concepts in hardware design. All Acqiris Crates are warranted to operate within specification, assuming normal operation, for a period of three years from the date of shipment. All repairs, replacement and spare parts are warranted for a period of 3 months.

In exercising this warranty, Acqiris will repair or replace any product returned to the Customer Support Center, or an Authorized Repair Center, within the warranty period. The warranty covers all defects that are a result of workmanship or materials. This excludes defects that are caused by accident, misuse, neglect, or abnormal operation.

### 1.10. Warranty and Repair Return Procedure

The purchaser is responsible for returning the goods to the nearest Customer Support Center. This includes transportation costs and insurance. Acqiris will return all warranty repairs with transportation prepaid.

Before returning any Acqiris product for repair please contact your nearest service center for a **Return Authorization Number (RAN)**. In order to issue your RAN we will require your name, company, phone number and address, the model and serial numbers of the unit to be repaired and a brief description of the problem.

As well as providing you with an RAN Acqiris Support Centers can assist you with any questions concerning the installation, operation or service of your equipment.

**Assistance and Support** : For your nearest customer support center contact Acqiris at :

- +41 22 884 33 90 in Europe
- 1-877-ACQIRIS in the USA
- +61 3 9888 4586 in the Asia-Pacific region

### 1.11. Maintenance

The CC121 crates do not require any maintenance. There are no user serviceable parts inside.

### 1.12. Cleaning



**WARNING** : Always power off the crate and disconnect the power cord before cleaning the crate.

Cleaning procedures consist only of exterior cleaning.

Clean the exterior surfaces of the crate with a dry lint-free cloth or a soft-bristle brush. If any dirt remains, wipe with a cloth moistened in a mild soap solution. Remove any soap residue by wiping with a cloth moistened with clear water. Do not use abrasive compounds on any part of the crate.



**CAUTION** : Avoid getting moisture inside the crate during exterior cleaning. Use just enough moisture to dampen the cloth.

*Do not wash the connector and switch. Cover these components while cleaning the crate.*

*Do not use chemical cleaning agents, they may damage the crate. Avoid chemicals that contain benzene, toluene, xylene, acetone, or similar solvents.*

### 1.13. Disposal and Recycling



Electronic equipment should be properly disposed of. Acqiris Digitizers and their accessories must not be thrown out as normal waste. Separate collection is appropriate and may be required by law.

## 2. INSTALLATION

### 2.1. Configuration



**WARNING:** Before connecting the crate to a power source, read this chapter and the paragraph 1.5.

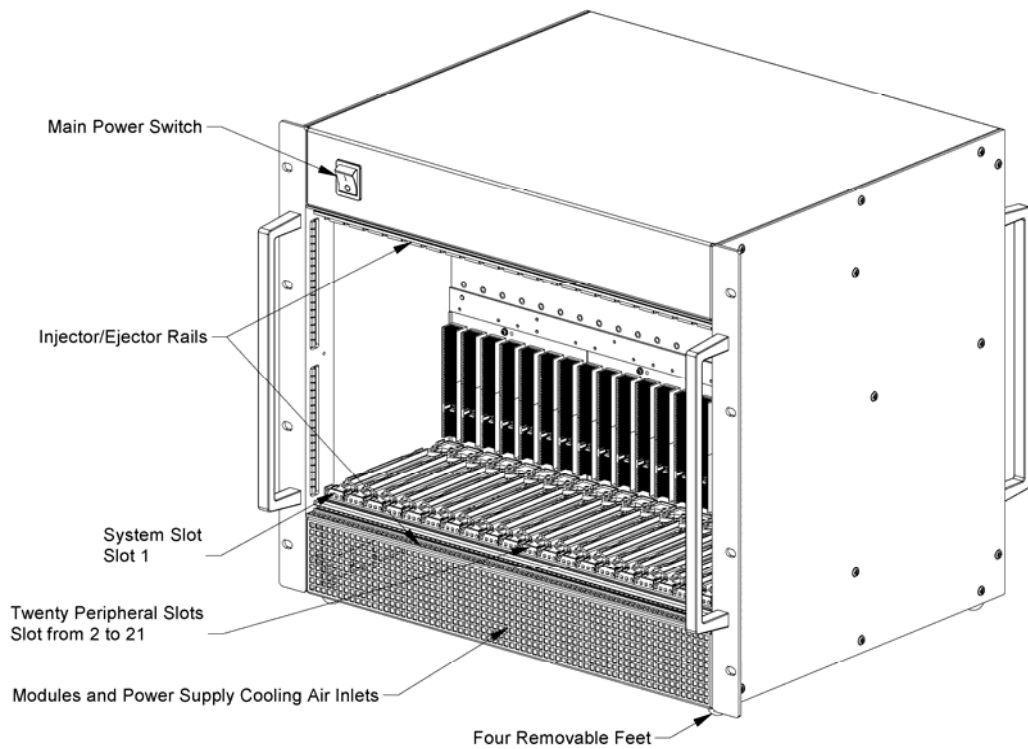

Figure 1: Front view of the CC121

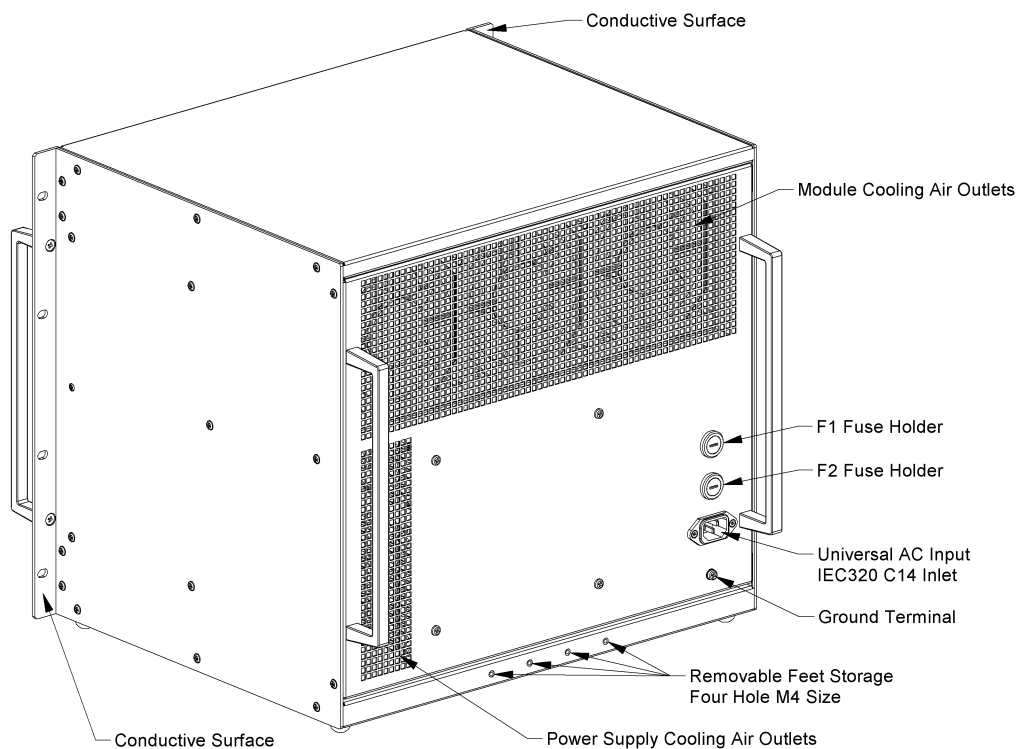

Figure 2: Rear view of the CC121



## 2.2. Site Considerations

The CC121 is designed to be used either in a 19-inch instrument rack or in a bench-top configuration. It is delivered in the bench-top configuration with four feet screwed into the holes provided on the bottom of the crate.

**NOTE :** With the feet in the bench-top configuration, the crate height is slightly more than the standard 9U. In order to use the crate in a 19-inch instrument rack, the user must unscrew the feet and, to avoid losing them, screw them back into the stocking holes provided in the lower part of the rear panel.



**CAUTION :** Keep other equipment a minimum of 75mm (3in.) away from the air inlets and outlets.

## 2.3. AC Mains Power

### 2.3.1. Connecting to AC Mains Power



**CAUTION :** Make sure that the main power switch is in the 0 position (OFF) before connecting the power cord to AC mains power.

The power supply is universal, which means that the crate can connect to all standard worldwide input voltages. Attach input power through the rear panel AC Line inlet using the appropriate power cord supplied. Refer to the paragraph 1.7. *Packaging and Handling* for the power cord specification.

### 2.3.2. Fuses



**WARNING :** The value of the F1 and F2 power line fuses depend of the AC power input voltage. For safety reasons, please follow the instructions shown in the table below. Disconnect the power cord before replacing the fuses.

The F1 and F2 power-line fuse-holders are located on the rear panel.

85 – 132 VAC	5x20mm slow-blow fuse: T 16A H 250V	Acqiris PN: EF011160A
190 – 264 VAC	5x20mm slow-blow fuse: T 8A H 250V	Acqiris PN: EF010800A

For continued protection against fire hazard, replace only with a fuse of the same type and correct rating.

## 2.4. Installing CompactPCI Modules



**CAUTION :** Turn off the crate power before installing or removing CompactPCI modules.



**NOTE :** The crate controller must be placed in the **System Slot** (slot 1) located at the left of the crate. The System Slot is identified with the number 1 surrounded with a triangle. All other modules are to be placed in the **Peripheral Slots** that are identified with their respective number surrounded with a circle.



**NOTE :** If you want the driver to automatically recognize the crate as a CC121 you should put at least one Acqiris acquisition module into one of the last 7 slots. If you do not do this, you can use the GeoMapper application discussed in the User Manual to create an AqGeo.map file.



**NOTE :** If you want to chain other CC121 crates to this one, please put the additional Acqiris MXI-3 PXI8335 modules in slots 2-4 of this upstream crate.



**NOTE :** The CC121 crate accepts PXI modules, but does not provide PXI-specific features (Local Bus, Trigger Bus, System Reference Clock).

### 2.4.1. Installing 6U modules

Install a module into the crate slot by first placing the module's card edges into the front module guides (top and bottom). Place both injector/ejector handles in the open position and slide the module to the rear of the crate. When you begin to feel resistance, push simultaneously both injector/ejector handles towards the center to plug the module into the backplane connectors of the crate. Secure it by clipping the handles into place. Tighten both front panel mounting screws to lock the module into place and insure proper grounding of the frame.

### 2.4.2. Installing 3U modules



**CAUTION:** *The XC100 6U to 3U Slot Adapter must be installed prior to inserting any 3U module into the CC121 crate. The XC100 is necessary to guide the 3U module and avoid damaging backplane connectors.*

Insert the XC100 into the module guide of the top part of the 6U slot. Turn the front panel knob in the clockwise direction to fasten the slot adapter into place. Tighten its front panel screw to insure proper grounding of the frame.

**NOTE:** *Refer to the appendix 4.1 XC100 6U to 3U Slot Adapter, Specifications and Assembly Instructions.*

Install a 3U module into the crate slot by first placing the module's card edges into the top and bottom guides. Place the injector/ejector handle in the open position and slide the module to the rear of the crate. When you begin to feel resistance, raise the handle to plug the module into the backplane connectors of the crate. Secure it by clipping the handle into place. Tighten both front panel mounting screws to lock the module into place and insure proper grounding of the frame.

### 2.4.3. Installing Filler Plug-in



**CAUTION:** *The CC121 crate should not be used without closing all unused or empty slots.*

To guarantee EMC performance and adequate cooling, install an optional **XC200 Filler Plug-in** or other filler panels conform to IEEE1101.10 into all unused slots. Tighten both captive mounting screws to lock the panel into place and insure proper grounding of the frame.

**NOTE:** *Refer to the appendix 4.2 XC200 6U Filler Plug-in, Specifications and Assembly Instructions.*

### 3. SPECIFICATIONS

#### 3.1. Main Features

The main features of the CC121 CompactPCI crate include :

- 19 inch rack-mount crate, 9U high, 21 vertical slots with *System Slot* at the left and 20 *Peripheral Slots*.
- CompactPCI (PICMG 2.0 R3.0) 6U and 3U module compatibility. The Backplane has three segments of seven slots linked with two CompactPCI bridge modules. These bridges are plugged on the rear of the backplane and all the slots are available for the application with complete access from the front side. The Backplane is equipped with P1 and P2 connectors, with V I/O to 5V and 5V coding keys assembled. A CompactPCI 3U module must be used with the optional XC100 Slot Adapter. The crate accepts PXI modules, but does not provide PXI-specific features.
- Optimized cross-flow air circulation. Power supply and module slots are cooled separately and fully protected against over-temperature.
- Meets the IEEE 1101.10 standard for EMC compatibility and optimized cooling.
- Front panel Power Switch.
- Quality 1260W usable power supply with universal AC input, power factor correction, auto-voltage and auto-frequency ranging.
- *Derating* (DEG) and *Supply Fall* (FAL) signals provided from the power supply to backplane *System Slot* (P2 connector).
- Handles on the front and rear sides for easy handling
- Removable feet for bench-top applications and in rack-mount applications, four M4 size holes are provided on the rear panel for their storage.

#### 3.2. Power Supply

##### 3.2.1. AC Input Specifications

AC Input Voltage Range	Universal Input: 85 – 264 V
Input Frequency Range	Auto-Frequency Ranging: 47 - 440 Hz
Maximum Input Power	1900W
Power Factor Correction	Meets EN61000-3-2. Power Factor 0.99 typical
Efficiency	75% minimum
Inrush Current	40A peak maximum
Leakage Current	2.4mA maximum @ 264VAC
Holdover Storage	30msec minimum @ full load. Independent of AC input voltage.
AC Input Fuses	F1 and F2 located on the rear panel. <b>85 –132V:</b> Slow-Blow: T 16A H 250V, 5x20mm <b>190 – 264V:</b> Slow-Blow: T 8A H 250V, 5x20mm
AC Input Inlet	IEC320 C14
Internal Input Fuse (F1)	Type KLK25, 25A, 600V, manufactured by Littelfuse.
Power Supply Cooling	Three internal DC Fans. The airflow direction is from the front to the rear of the crate.

### 3.2.2. DC Outputs Specifications

Maximum Usable Power	1900W @ 230VAC, 1260W @ 115VAC
Output Voltages	+3.3V: +3.3 ±0.1V +5V: +5.1 ±0.1V +12V: +12.15 ±0.15V -12V: -12.15 ±0.15V
Maximum Output Currents	+3.3V: 120A (400W) +5V: 120A (600W) +12V: 50A (600W) -12V: 25A (300W)
RMS Ripple	0.1% or 10mV whichever is greater. 20MHz bandwidth
Peak to Peak Noise	1% or 50mV whichever is greater. 20MHz bandwidth
Dynamic Response	<2% or 100mV @ 25% load step
Recovery Time	To within 1% in <0.3msec
Over-Current Protection	All outputs are protected from short circuit and overload. Automatic recovery.
Over-Voltage Protection	<b>3.3V and 5V:</b> 122-134%, <b>+12V and -12V:</b> 110-120%. Turn OFF the crate to reset the Over Voltage Protection.
Thermal Protection	<b>All outputs:</b> disabled when the power supply internal temperature exceeds safe operating range. Automatic recovery. <b>Each output:</b> individually protected. Turn OFF the crate to reset the Individual Protection. Warning signal (FAL#) >5msec before shutdown.

### 3.3. Slot Specifications

Slots	Height: 6U, Width: 20.32mm (0.8 in.). 1 System Slot, 20 Peripheral Slots.
Module Cooling System	Forced air circulation separated from the power supply cooling. The airflow direction is from the front to the rear of the crate. Slot airflow direction from the bottom to top of the modules. Three 50 l/s (106 cfm) axial fans.
Airflow per Slot	Typical 6 l/s (12.7 cfm). Velocity 2.4 m/s (480 lfm) @ 70% cross-section aperture.
Per Slot Cooling Capacity	Maximum 60W
Slots Thermal Protection	Separated from the power supply thermal protection. All power supply outputs are shutdown when the slot environment exceeds safe operating temperature (60°C). Warning signal (FAL#) <4msec after the beginning of the shutdown. Automatic recovery.
Per Slot Current Capacity	See paragraph 3.4.1 Working Currents.
Maximum Module Weight	1.5 kg (3.3 lb.)

Slot Numbering Convention	Physical	Logical (decimal)
	1, 8, 15	4
	2, 9, 16	15
	3, 10, 17	14
	4, 11, 18	13
	5, 12	9
	6, 13, 20	11
	7, 14, 21	10
	19	12

### 3.4. Backplane

#### 3.4.1. Backplane Specifications

Conformity	CompactPCI: PICMG 2.0 R3.0 UL recognized
Configuration	21 Slots, 1 System Slot to left, 20 Peripheral Slots. Three segments of seven slots linked with two transparent bridges plugged on the rear of the backplane. All the slots are available for the application with complete access from the front side.
Size	Height 3U: P1 and P2 connectors (32/64 bit).
Bus Frequency	33 MHz
GND (Common Return Outputs)	Connected to Chassis.
V I/O Voltage	Connected to +5V
Coding Keys	5V coding key assembled, brilliant blue
Material	FR4: UL 94V0 recognized
Connectors P1 (Module A) and P2 (Module B)	Conforms to IEC917 and IEC 1076-4-101. UL 94V0 rated.
Working Currents	1.5A@25°C max per contact (1.2A@50°C). Power supply contacts per slot, connectors P1 and P2: +3.3V: P1; 10 contacts +5V: P1; 8 contacts +12V: P1; 1 contact -12V: P1; 1 contact V(I/O): P1; 5 contacts P2; 6 contacts GND: P1; 14 contacts P2; 18 contacts

### 3.4.2. Power Supply Status

The *Derating* (DEG#) and *Supply Fail* (FAL#) are implemented only for the System Slot.

Levels	TTL levels, require pull-up resistor to +5V (2kOhm) on the System Controller Board.
DEG# Mains AC accurate signal	Indicate that the power supply is beginning to derate its power outputs. 1 = Mains AC is accurate. 0 to 1: 2msec minimum after the DC outputs are accurate. 1 to 0: 20msec minimum before FAL# and DC outputs are shutdown.
FAL# Global DC outputs accurate signal	Indicate that a DC output from the power supply has a failure. 1 = All DC outputs are accurate. 0 to 1: 1msec maximum before the DC outputs are accurate. 1 to 0: 4msec maximum after the start of the DC output shutdown.

## 3.4.3. Connector Pinouts

Connector	Pin	Z	A	B	C	D	E	F	
P2 (J2)	22	GND	GA4	GA3	GA2	GA1	GA0	GND	
	21	GND	CLK6	GND	RSV	RSV	RSV	GND	
	20	GND	CLK5	GND	RSV	GND	RSV	GND	
	19	GND	GND	GND	RSV	RSV	RSV	GND	
	18	GND	BRSVP2A18	BRSVP2B18	BRSVP2C18	GND	BRSVP2E18	GND	
	17	GND	BRSVP2A17	GND	PRST#	REQ6#	GNT6#	GND	
	16	GND	BRSVP2A16	BRSVP2B16	DEG#	GND	BRSVP2E16	GND	
	15	GND	BRSVP2A15	GND	FAL#	REQ5#	GNT5#	GND	
	14	GND	AD[35]	AD[34]	AD[33]	GND	AD[32]	GND	
	13	GND	AD[38]	GND	V(I/O)	AD[37]	AD[36]	GND	
	12	GND	AD[42]	AD[41]	AD[40]	GND	AD[39]	GND	
	11	GND	AD[45]	GND	V(I/O)	AD[44]	AD[43]	GND	
	10	GND	AD[49]	AD[48]	AD[47]	GND	AD[46]	GND	
	9	GND	AD[52]	GND	V(I/O)	AD[51]	AD[50]	GND	
	8	GND	AD[56]	AD[55]	AD[54]	GND	AD[53]	GND	
	7	GND	AD[59]	GND	V(I/O)	AD[58]	AD[57]	GND	
	6	GND	AD[63]	AD[62]	AD[61]	GND	AD[60]	GND	
	5	GND	C/BE[5]#	GND	V(I/O)	C/BE[4]#	PAR64	GND	
	4	GND	V(I/O)	BRSVP2B4	C/BE[7]#	GND	C/BE[6]#	GND	
3	GND	CLK4	GND	GNT3#	REQ4#	GNT4#	GND		
2	GND	CLK2	CLK3	SYSEN#	GNT2#	REQ3#	GND		
1	GND	CLK1	GND	REQ1#	GNT1#	REQ2#	GND		
P1 (J1)	25	GND	5V	REQ64#	ENUM#	3.3V	5V	GND	
	24	GND	AD[1]	5V	V(I/O)	AD[0]	ACK64#	GND	
	23	GND	3.3V	AD[4]	AD[3]	5V	AD[2]	GND	
	22	GND	AD[7]	GND	3.3V	AD[6]	AD[5]	GND	
	21	GND	3.3V	AD[9]	AD[8]	M66EN	C/BE[0]#	GND	
	20	GND	AD[12]	GND	V(I/O)	AD[11]	AD[10]	GND	
	19	GND	3.3V	AD[15]	AD[14]	GND	AD[13]	GND	
	18	GND	SERR#	GND	3.3V	PAR	C/BE[1]#	GND	
	17	GND	3.3V	SDONE	SBO#	GND	PERR#	GND	
	16	GND	DEVSEL#	GND	V(I/O)	STOP#	LOCK#	GND	
	15	GND	3.3V	FRAME#	IRDY#	GND	TRDY#	GND	
	12-14	KEY AREA							
	11	GND	AD[18]	AD[17]	AD[16]	GND	C/BE[2]#	GND	
	10	GND	AD[21]	GND	3.3V	AD[20]	AD[19]	GND	
	9	GND	C/BE[3]#	IDSEL	AD[23]	GND	AD[22]	GND	
	8	GND	AD[26]	GND	V(I/O)	AD[25]	AD[24]	GND	
	7	GND	AD[30]	AD[29]	AD[28]	GND	AD[27]	GND	
	6	GND	REQ#	GND	3.3V	CLK	AD[31]	GND	
	5	GND	BRSVP1A5	BRSVP1B5	RST#	GND	GNT#	GND	
4	GND	BRSVP1A4	GND	V(I/O)	INTP	INTS	GND		
3	GND	INTA#	INTB#	INTC#	5V	INTD#	GND		
2	GND	TCK	5V	TMS	TDO	TDI	GND		
1	GND	5V	-12V	TRST#	+12V	5V	GND		

## Notes:

1. All pins are medium length (level 2) except on the connector P1 pin C16 which is long (level 3) and D15 which is short (level 1).
2. The following positions of connector P2 are implemented only on the System Slot: A1-3, A19-21, B2, B19-21, C1-3, C15-17, D1-3, D15, D17, E1-3, E15, E17.
3. Connector P2 pin C2 is connected to GND at the System Slot only.

### 3.5. Environmental

#### 3.5.1. Environmental Specifications

\* Environmental specifications in accordance with MIL-PRF-28800F Class 3.

Operating Location	Indoor use
Operating Temperature	0° to 45° C
Storage Temperature *	-40° to 85° C
Operating Relative Humidity *	5 to 95% non-condensing
Operating Altitude	3000 m
Random Vibration *	5 to 500Hz, 0.44 g peak, operating 10 to 500Hz, 3.5 g peak, non-operating
Operating Shock *	Half-sine pulse, 11ms duration, 30 g peak

#### 3.5.2. Safety

In accordance with Council Directive 73/23/EEC, Low Voltage Safety.

Conformity	EN61010-1 Installation Category II, Pollution Degree 2 Safety Class 1
------------	---

#### 3.5.3. EMC Emission

In accordance with Council Directive 89/336/EEC, Electromagnetic Compatibility.

Conformity	EN61326-1: 1997, A1: 1998
Radiated Electromagnetic Field	EN55011: 1998. Class B
Conducted Disturbance Voltage	EN55011: 1998. Class B
Harmonic Currents	EN61000-3-2: 1995, A13: 1997, A1: 1998, A2 : 1998 A14: 2000.
Flicker	EN61000-3-3: 1995. The crate produces no flicker.

#### 3.5.4. EMC Immunity

In accordance with Council Directive 89/336/EEC, Electromagnetic Compatibility.

Conformity	EN61326-1: 1997, A1: 1998. Industrial Environment.
Electrostatic Discharge (ESD)	EN61000-4-2: 1995. Air 8kV, contact 4kV.
Electromagnetic Fields	EN61000-4-3: 1996. 80 to 1000MHz, 10V/m.
Fast Electric Transients (Burst)	EN61000-4-4: 1995. 2kV.
Surge	EN61000-4-5: 1995. Line to Earth impulse 2kV, Line to Line impulse 1kV.
Conducted Disturbances	EN61000-4-6: 1996. 0.15 to 80MHz, 3V.
Magnetic Field	EN61000-4-8: 1993. No element sensible to magnetic field 50 to 400Hz.
Voltage Dips and Short Interruptions	EN61000-4-11: 1994. Voltage reduction 100%, Duration 10msec, Phase 0°, 90°, 180°, 270°.



### 3.6. Mechanical

#### 3.6.1. Mechanical Specifications

Overall Dimensions	Width: 483mm (19 in.) Depth: 440mm (17.32 in.) including the handles Height: 399mm (15.71 in.) 9U 411mm (16.18 in.) including the feet
Weight	19.9kg (43.9 lb.)
Material and Finish	Enclosure: Steel sheet. Zinc plated. Outward painted Aluminum extrusion. Clear chromated Aluminum sheet. Clear chromated. Outward painted Handles: Aluminum. Black anodized Bus Bars: Copper. Nickel plated Card Guides: Molded plastic (UL 94V0 rated)

#### 3.6.2. Dimensions

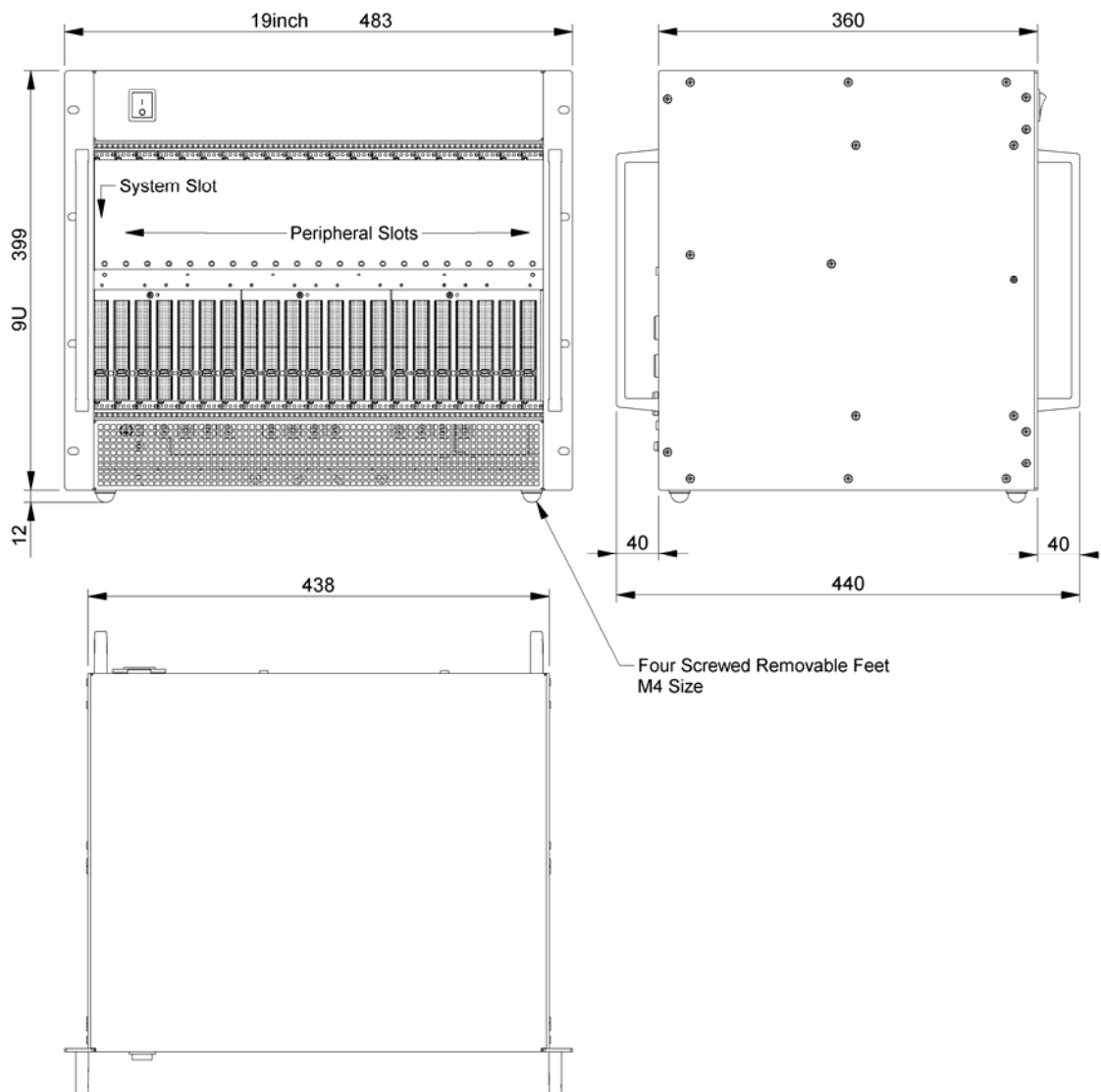

## 4. APPENDICES

### 4.1. XC100 6U to 3U Slot Adapter

#### Specifications and Assembly Instructions

##### **SPECIFICATIONS :**

The XC100 6U to 3U slot adapters are specially designed for use with Acqiris CompactPCI crates. The XC100 allows the use of 3U CompactPCI modules in any vacant 6U slot.

##### **CAUTION :**

The XC100 6U to 3U slot adapter must be installed prior to inserting any 3U CompactPCI module into any Acqiris CompactPCI crate. The XC100 assures proper mechanical alignment when inserting a 3U module and protects the crate's backplane connectors from damage. In addition, the XC100 provides the function of a blanking panel to completely close the vacant slot. This function is essential to guarantee EMC shielding and adequate cooling.

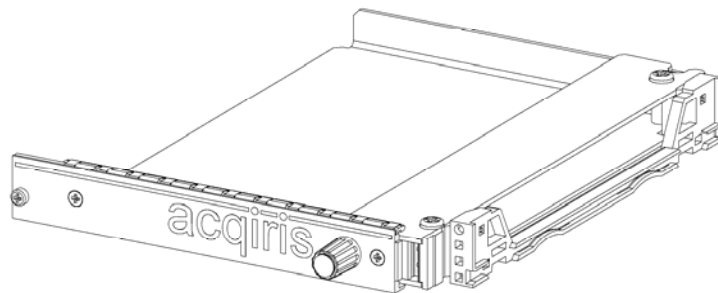

##### **ASSEMBLY INSTRUCTIONS :**

1. Insert the XC100 into the left part of the chosen 6U slot.
2. Turn knob "A" in the clockwise direction to fasten the unit into place.
3. Fasten screw "B" to insure proper grounding of the frame.

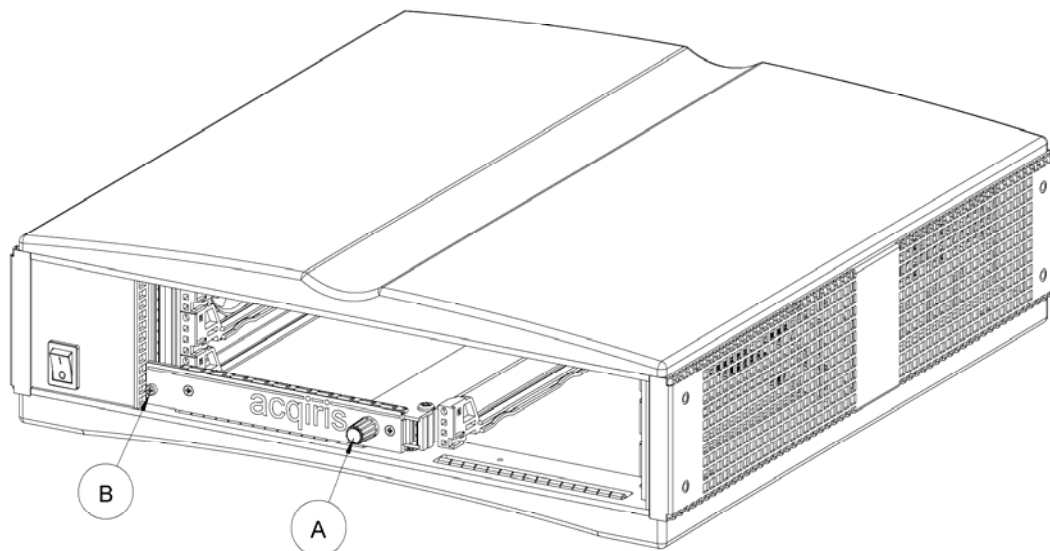

## 4.2. XC200 6U Filler Plug-in

### Specifications and Assembly Instructions

#### SPECIFICATIONS :

The XC200 filler plug-in is used to close vacant slots in Acqiris' 6U CompactPCI Crates.

#### CAUTION :

The XC200 filler panel is required to guarantee EMC shielding and adequate cooling. Crates should not be used without closing all vacant front panel slots.

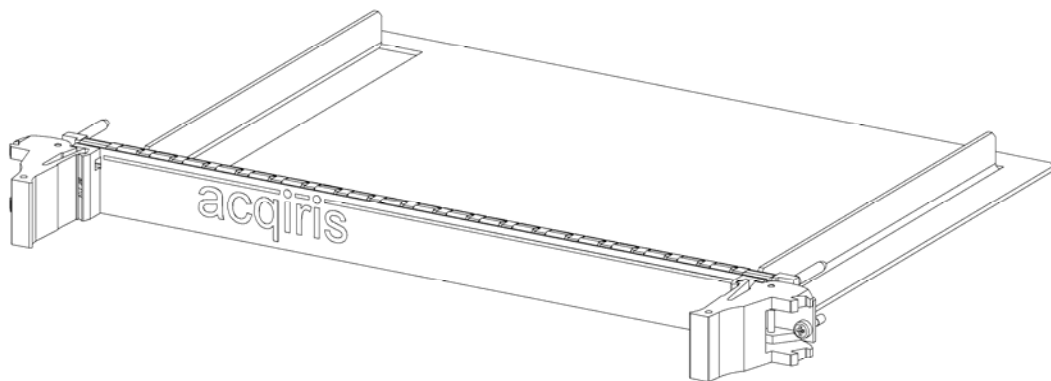

#### ASSEMBLY INSTRUCTIONS :

1. Insert the XC200 in the chosen slot by holding the handles on each side.
2. Gently push the XC200 into the slot and secure it by clipping the handles into place.
3. Tighten both screws "A" to lock the XC200 into place and insure proper grounding of the frame.

