

EMI AMERICA SERIES MULTI-ZONE LIMITED RANGE HEAT PUMP CONDENSING UNITS

S2HA HEAT PUMPS

Nominal Circuit Capacities:

9,000 & 12,000 Btuh units.

EMI  **AmericaSeries**

Comfort Where It Counts.

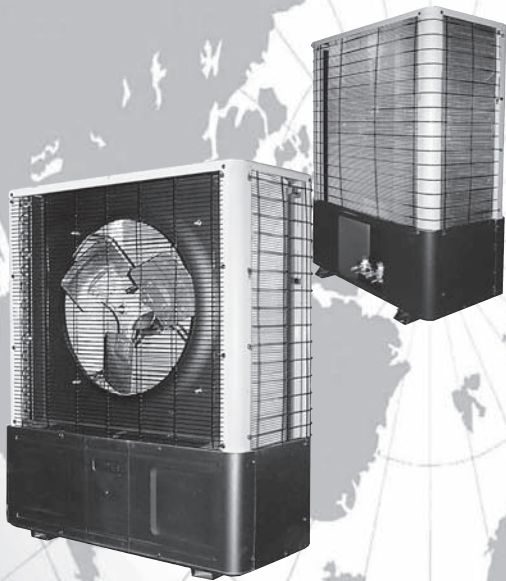

S2HA Multi-Zone

Enviromaster International LLC
5780 Success Dr.
Rome, NY 13440
www.enviromaster.com

An  **ECR** International Brand
An ISO 9001-2000 Certified Company



P/N# 240006458 Rev. 1.0 [01/07]

EMI AMERICA SERIES MULTI-ZONE HEAT PUMP CONDENSING UNITS

INSTALLATION, OPERATION AND MAINTENANCE MANUAL

P/N 240006458, Rev. 1.0 [01/07]

This manual is intended as an aid to a qualified service personnel for proper installation, operation, and maintenance of these EMI America Series multi-zone heat pump condensing units. Read the instructions thoroughly and carefully before attempting installation or operation. Failure to follow these instructions may result in improper installation, operation, service, or maintenance, possibly resulting in fire, electrical shock, property damage, personal injury, or death.

***Shipping Damage MUST be Reported to the Carrier IMMEDIATELY!!!
Examine the carton for signs of damage if any is evident open packaging and
check the unit for shipping damage.***

TO THE INSTALLER

- (1) Retain this manual and warranty for future reference.
- (2) Before leaving the premises, review this manual to be sure the unit has been installed correctly and run the unit for one complete cycle to make sure it functions properly.

To obtain technical service or warranty assistance during or after the installation of this unit, check our website @ www.enviromaster.com or call your installing contractor or distributor. Our technical service department may be contacted at 1-800-228-9364.

When calling for assistance, please have the following information ready:

- Model Number _____
- Serial Number _____
- Date of installation _____

DANGER

Tampering with the EMI America Series condenser is dangerous and may result in serious injury or death. Tampering voids all warranties. Do not attempt to modify or change this unit in any way.

SAFETY INSTRUCTIONS

- ▲ Read all instructions before using the EMI America Series multi-zone heat pump condenser. Install or locate this unit only in accordance with these instructions. Use this unit only for its intended use as described in this manual.
- ▲ Check the rating plate on the EMI America Series multi-zone heat pump condenser before installation to make certain the voltage shown is the same as the electric supply to the unit.
- ▲ The EMI America Series multi-zone heat pump condenser must be connected only to a properly grounded electrical supply. Do not fail to properly ground this unit.
- ▲ Turn off the electrical supply before servicing the EMI America Series multi-zone heat pump condenser.
- ▲ Do not use the EMI America Series multi-zone heat pump condenser if it has damaged wiring, is not working properly, or has been damaged or dropped.

[Save These Instructions]



Recognize this symbol as an indication of important safety information.



EMI AMERICA SERIES MULTI-ZONE HEAT PUMP CONDENSING UNITS

DESCRIPTION

EMI offers the finest dual zone heat pump outdoor units in the ductless split market, the S2HA Condensing Unit. The S2HA allows the installation of two circuits from a single outside location when space or aesthetic requirements limit the use of the number of cabinets outdoors. Each zone is independent so no mixing of refrigerant occurs.

When specifying heat pump(s), it is recommended that the matching indoor unit(s) be equipped with electric heat. The S2HA will operate down to 35°F outdoor temperature, at which point it will initiate change over to electric heat and shut down the condenser. All 9,000, and 12,000 Btu/h circuit units are equipped with the Duratec Performance Package which include a large capacity suction accumulator with surge baffles and enhanced oil management, a factory installed solid core filter drier and loss of refrigerant charge protection.

NOTE: The crankcase heater is installed with 9,000 and 12,000 Btu/h heat pumps.

CONTROLS AND COMPONENTS (FACTORY INSTALLED OR SUPPLIED)

- Compressor and Fan Motor Contactor
- Capacitor
- Loss of Charge Switch
- Low Voltage Connections
- Large Capacity Suction Accumulator
- High Pressure Control
- Solid Core Filter Drier
- Crankcase Heater
- Common suction pressure access point

SYSTEM OPTIONS

- Sea Coast Style Coated Coils / Copper-Copper coils
- Wind Baffles - Louvers

INSTALLER SUPPLIED ITEMS

- Power wiring
- Low Volt wiring - 18 AWG minimum
- Secure mounting pad or foundation
- Refrigerant piping (if not supplied)
- Disconnect switch

ITEMS FOR CONSIDERATION

- Locate the unit as close to the indoor section as possible. Maximum length allowed is 100 equivalent feet.
- Avoid high traffic areas and prevailing wind locations.
- Surface must be level.
- Mount unit above typical snow levels.

Ensure free flow of air through the unit. Air must not recirculate from discharge to intake. Air is drawn through the coil with side, or top discharged through the fan grille. **A minimum 48" clearance is necessary for the condenser discharge. Intake (coil side) clearance is 12" minimum.** Consider how power will be run to the unit from the power source. Refrigerant piping must be a direct line to the indoor unit.

Heat pump units produce condensate in the heat pump mode. Water will drain from the unit at the base. Place the unit so as not to create a hazard for pedestrians.

SITE PREPARATION

Place the unit on a flat concrete surface or pad if on the ground. Roof mounting should use a built up platform. Piping is through the wall or roof directly to the unit. In areas of heavy snowfall, condensers should be set above the level of maximum anticipated snowfall (12" is usually adequate).

INSTALLATION INSTRUCTIONS

UNIT MOUNTING SECTION

Side discharge unit allows for permanent mounting through the feet. ***This is highly recommended due to the vertical design of the unit.***

1. Loosen the screws on left and right sides of the front panel. (Do not remove these screws.)

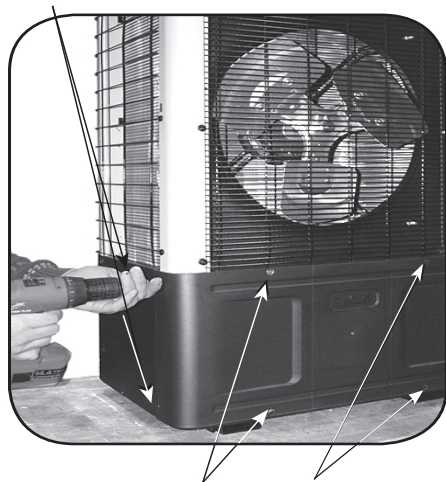

2. Remove the screws on the front of the panel.

3. To remove front panel:

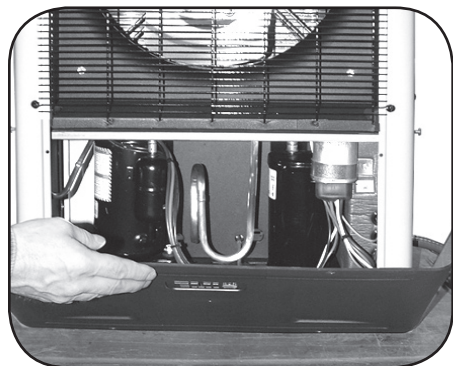

4. Slide front panel forward to clear side screws and remove.

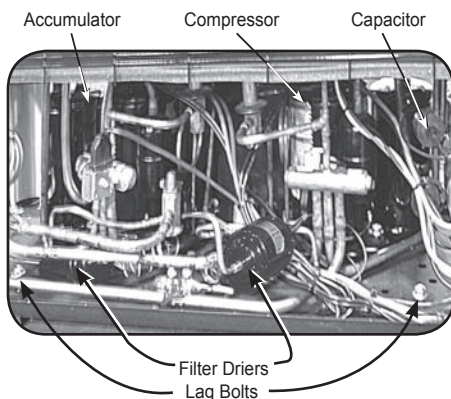

5. Insert lag bolts through the holes in the bottom of the unit and tighten to secure.

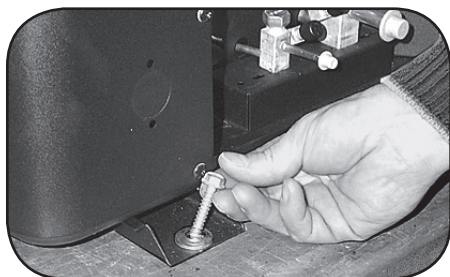

6. Insert lag bolts through the holes in the feet on the back of the unit and tighten to secure.

7. Replace the front panel, ***do not*** tighten the side screws at this time.

ELECTRICAL WIRING INSTALLATION SECTION

⚠ DANGER ⚠

The EMI America Series condensing unit must:

- Be connected to a properly grounded electrical supply with the proper voltage as stated on the rating plate.
- Have proper over current protection (i.e. time- delay fuse/HACR-Breaker) as listed on the Rating Plate.

Failure to follow these instructions can result in a fire, explosion, or electrical shock causing property damage, personal injury, or death.

⚠ DANGER ⚠

Do not use the EMI America Series condensing unit with any electrical supply voltage other than the one listed on the rating plate.

Check the rating plate on the unit for the correct voltage rating. Failure to use the correct voltage may result in death, serious bodily injury or property damage. If you have any questions or doubts, consult the factory before installing this unit.

1. All electrical wiring must be run according to NEC and local codes.
2. Refer to the unit rating plate for voltage, minimum circuit ampacity and over current protection requirements.



3. Use only HACR type breakers or time delay fuses. Select the wire size according to the ampacity rating.
4. To access electrical connections and wiring diagram:
 - a) Remove the screws on the side panel adjacent to the back panel.
 - b) The screws adjacent to the front panel should already be loose (don't remove them).

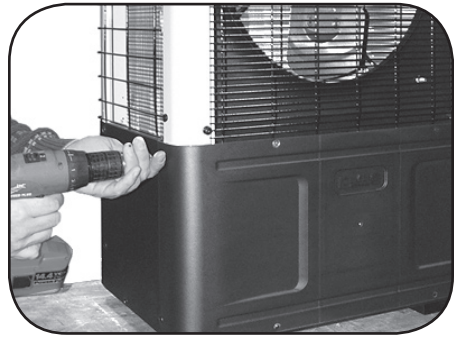

- c. Slide the side panel out to access the high/low electrical connections and wire diagram.

Note: Remove the plastic edge guards from the holes and replace with a water-tight strain relief fitting (High V) and a split grommet fitting (Low V)

5. Power should be run to a weather proof disconnect box usually within 3 feet of the unit.
6. From the disconnect box, run the power through the 7/8" hole on the side of the unit and into the electrical box and anchor with the strain relief fitting.
7. Run wires to the high Volt pigtail in the control box and attach L1 and L2 connections. Also run green wire to ground wire.

Note: Refer to the units' wiring diagram for all wiring.

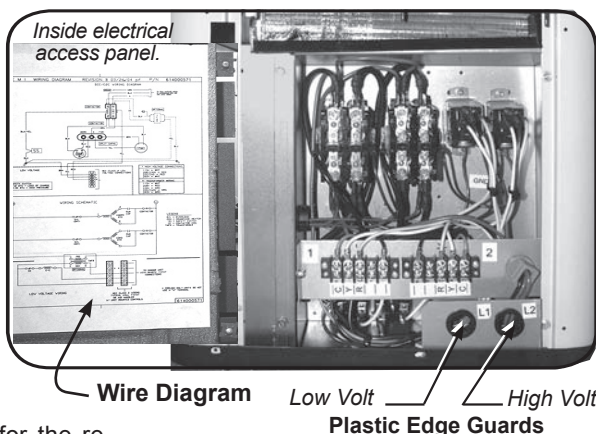

8. Check wiring diagram for the required number of low voltage wires to be run between indoor and outdoor sections.

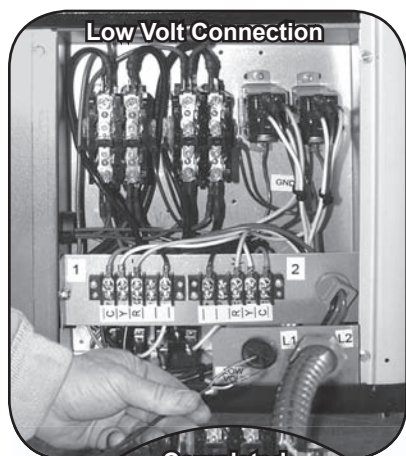

9. Connect the 24 Volt wiring matching color to color. Refer to the wiring diagram on the inside panel of the condenser, and also refer to the wiring diagram on the indoor unit. Low Volt interconnect should be at least 18 awg.

10. To replace side panel slide the slotted holes of the panel onto the loosened screws of the front panel so that the edge of the front panel covers the edge of the side panel.

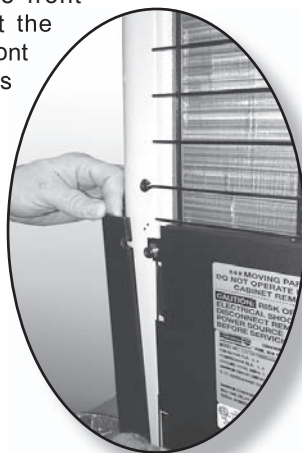
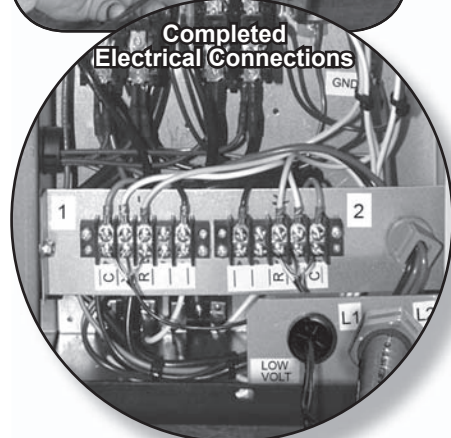

11. Fasten all remaining loose screws.

REFRIGERANT PIPING INSTALLATION SECTION

INTERCONNECTING TUBING SPECIFICATIONS

Model	MAX. Length	Max. Lift	Liquid Line O.D.	Suction Line O.D.
9900	100'	35'	1/4"	1/2"
2200	100'	35'	1/4"	1/2"
9200	100'	35'	1/4"	1/2"

The system will support refrigerant runs to the inside unit of up to 100' equivalent feet with a 35' rise included. The units are furnished with sweat connections and are equipped with refrigerant valves and Schrader fittings for charging and taking pressure readings. The following precautions should be made:

- Be certain no burrs remain on the fittings.
- Use only clean refrigeration tubing.
- Use tube benders to guard against kinking.
- Avoid piping on wet and rainy days and ***insulate suction line***. Be certain that plastic end caps remain in place when inserting through wall openings. Isolate tubing from transmitting vibration to the building or unit and avoid contact with sharp edges. **Refrigeration valves should be wrapped with a wet rag "heat sink" to protect valves while brazing.**

P-TRAP INSTALLATION

- A P-trap is recommended when the suction riser is equal to or greater than 20 feet in height.
- When the condenser is installed above the evaporator, the P-trap will help the return of oil back to the compressor.
- The placement of the P-trap should be at the halfway mark of the suction riser. For example if the suction riser is 30 feet tall then a P-trap is recommended at the 15 foot mark of the suction riser (see **Figure #1**).
- A P-trap may be fabricated using:
 - (2) street elbows and
 - (2) regular elbows. A prefabricated trap may be purchased from a Wholesaler

or Distributor however the trap should be shallow as the:

- (4) elbow configuration. Each elbow is approximately 2 equivalent feet. One P-trap is equal to approximately 8 equivalent feet.

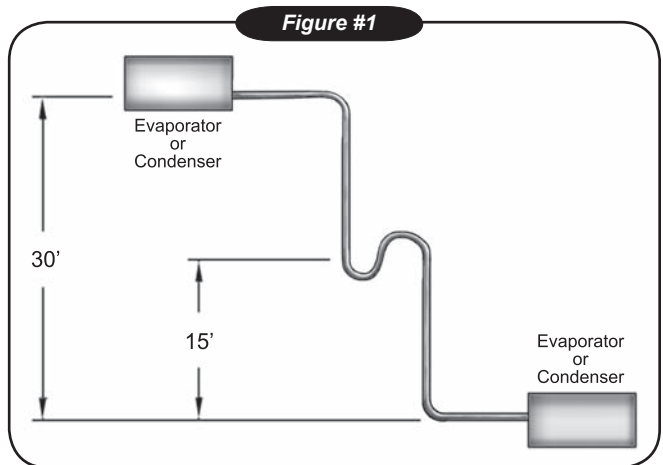

REFRIGERANT PIPING INSTALLATION SECTION

1. Clean the ends of tubing and insert into fittings.

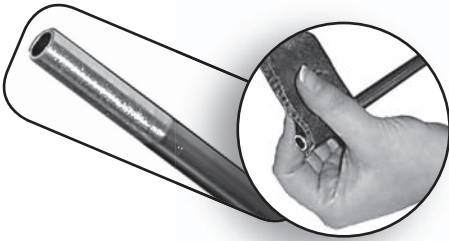

2. Protect the valves by wrapping with a wet rag "heat sink" before brazing.



3. The use of a shield is recommend (one can be made from some scrap metal) to protect the paint.

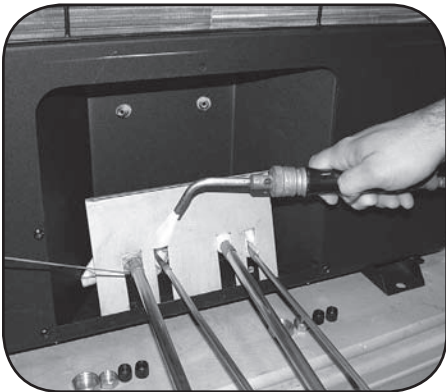

4. Braze tubing into fittings.

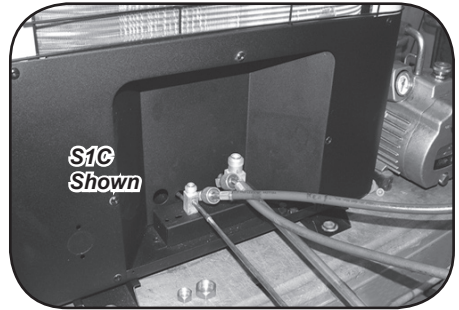

5. Verify that the correct piston for the system match is in place, refer to the air handler Installation Instructions.
6. Refer to the indoor air handler Installation Instructions for any specific details regarding the connection of tubing. Connect and braze tubing into the indoor air handler.
7. Attach manifold set.

Manifold Vaccum Pump Micron Gage

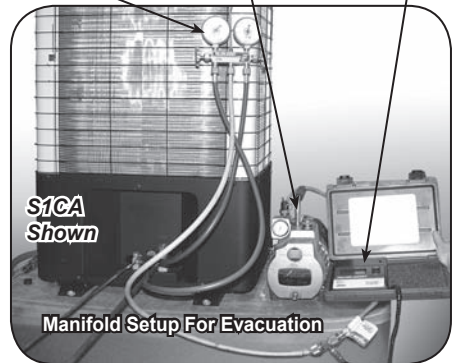

8. Evacuate line to 500 microns or less to ensure all moisture has been removed and there are no leaks.

⚠ WARNING ⚠

It is illegal to discharge refrigerant into the atmosphere. Use proper reclaiming methods & equipment when installing or servicing this unit.

REFRIGERANT PIPING INSTALLATION SECTION

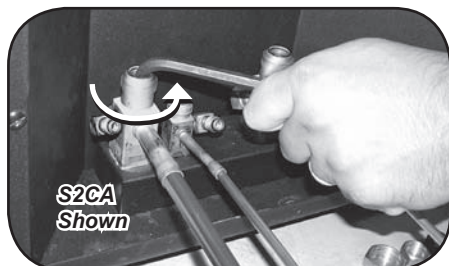
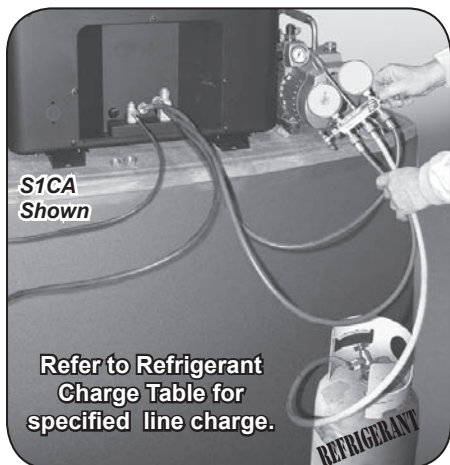

The units are delivered precharged with refrigerant for the condenser coil and the evaporator. Charging of the field installed piping is required. Refer to the refrigerant charge table for the proper amount to be added for the applications interconnect piping. Unit service valves are solid brass, for sweat connections.

Note: Charging should be done with a dial-a-charge or weighed in with a scale.

IMPORTANT: All systems require field charge adjustments. Refer to the "Refrigerant Charge Tables" for proper weight charge and to the supplied "Field Charging Charts" for proper system pressures and temperature at different outdoor conditions. Superheat should be used for final system charge in cooling mode. Subcool should be used for final system charge in heating mode.

9. Once certain of a good evacuation and leak free joints, back-seat the valves (counter-clockwise) to open and allow factory charge to fill lines and indoor unit.
10. Charge to proper weight, charge based on feet of interconnect (table on next page)

RECAP OF COMPLETING PIPING CONNECTIONS

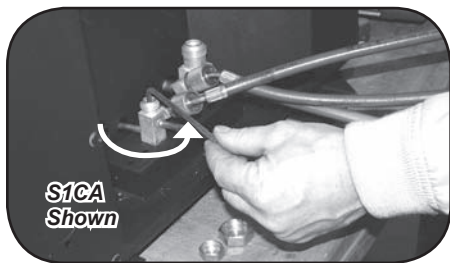

Pressure test all field installed piping and the indoor air handler with nitrogen. Using a suitable vacuum pump, evacuate the tubing and indoor unit to 500 microns or less, with service valves remaining front seated (closed).

11. Refer to *Field Charging Charts* to "fine tune" the refrigerant charge to meet your conditions.

Before releasing the refrigerant from the condenser, be sure the manifold gauge set is closed so as not to lose vacuum when shutting down the pump.

Release refrigerant from the condensing unit by back seating the service valve. Allen wrenches are used to open the valve. Replace valve caps. Be Careful to not back seat the valves past the snap flanges that hold the valve core in place.

REFRIGERANT PIPING INSTALLATION SECTION

REFRIGERANT CHARGE TABLE FOR S2HA

CIRCUIT CAPACITY	EVAPORATOR PAIRING	LINE CHG/FT	LINE LENGTH	LINE ADJUST	FACTORY CHARGE	SYSTEM TOTAL
					S2HA	S2HA
9,000 Btuh	WLHA09, CAHB12 WLHA12, CAHB12	.25 OZ.	10	3 OZ.	42	45
			25	6 OZ.		48
			50	13 OZ.		55
12,000 Btuh	WLHA12 CAHB12	.25 OZ.	10	3 OZ.	46	49
			25	6 OZ.		52
			50	13 OZ.		59

IMPORTANT NOTES:

- To find the charge adjustment and system charge for any evaporator and tubing length:
 $Line\ Adjustment = (Line\ Charge/FT) \times Line\ Length$
 $System\ Total = Factory\ Charge + Line\ Adjustment$
- Round to the nearest ounce and allow for gauges and hoses.

FIELD CHARGING

The use of the superheat method is highly recommended for field charging or checking the existing refrigerant charge in a system. Because each installation is different in terms of indoor air flow, refrigerant line length, etc., the factory charge may not be correct for every application. To assure the best performance from the air-conditioner, the refrigerant charge should be checked and adjusted, if need be, on each installation.

For proper superheat readings, a standard low-side refrigerant gauge and an accurate thermometer are needed. A mercury or stem-type thermometer is not adequate for suction-line temperatures. We recommend electric thermocouple thermometers (available at most refrigeration wholesal-

ers); however an accurate remote-bulb thermometer can be used. When measuring the line temperature, be sure the thermometer is well insulated to assure accurate measurements. The chart below gives superheat values at various outdoor temperatures. Allow at least 5 minutes running time between charge adjustments for the unit to stabilize.

The S2HA has manifold access points on each of the service valves for the high and low pressures in cooling mode. There is an additional "common suction" access point above each service valve set to provide low pressure access in the heating mode as both service valves are at high side pressure.

FIELD CHARGING

Cooling Cycle

S2HA 9,000 Btuh circuit

with EMI's-WLHA09 or CAHA12 (R-22 Ref.)

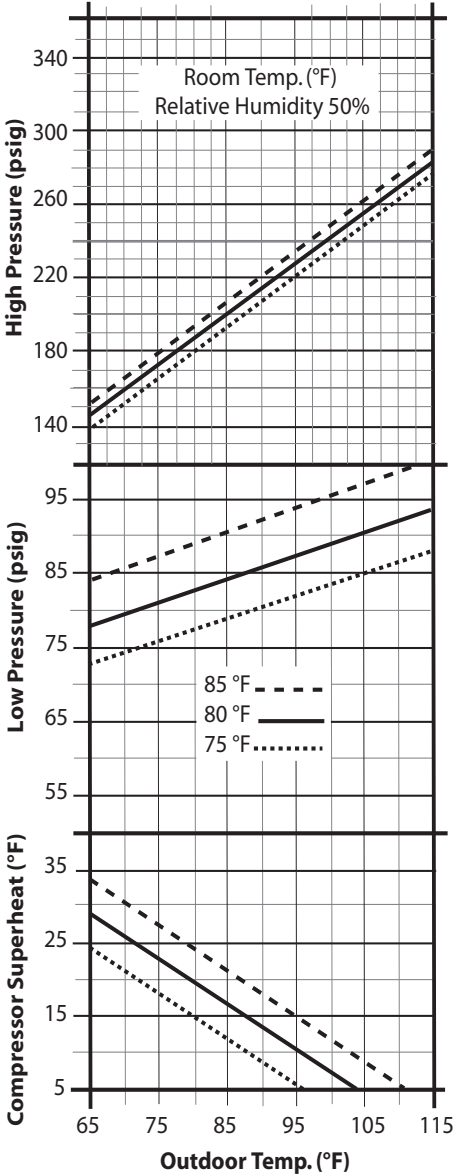

Note: Minimum compressor superheat 5° F

Cooling Cycle

S2HA 12,000 Btuh circuit

with EMI's-WLHA09 or CAHB12 (R-22 Ref.)

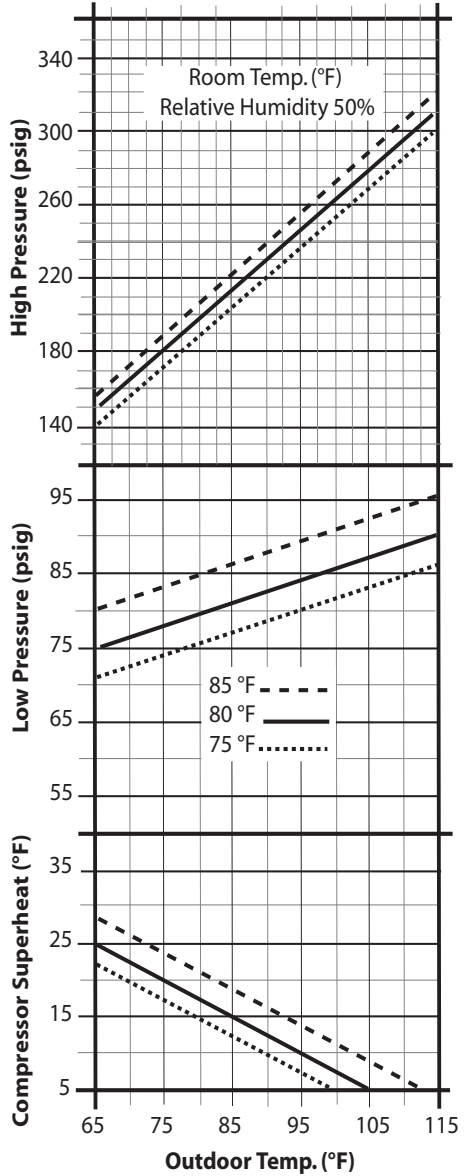

Note: Minimum compressor superheat 5° F

FIELD CHARGING

Heat Cycle S2HA 9,000 Btuh circuit

with EMI WLHA09 or CAHB12 (R-22 Ref.)

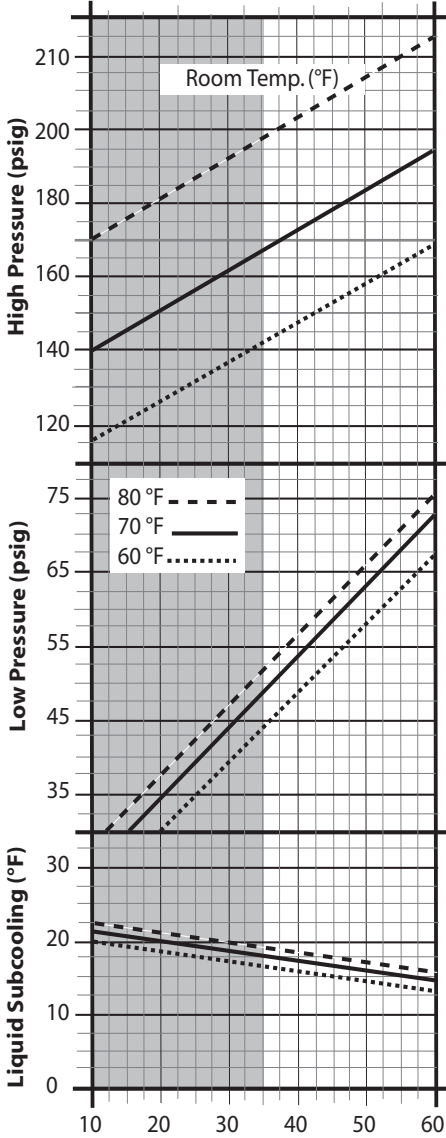

Outdoor Temp. (°F) RH - 50%

■ Shaded area is outside of the Limited Range Heating operation.

Heat Cycle S2HA 12,000 Btuh circuit

with EMI WLHA12 or CAHB12 (R-22 Ref.)

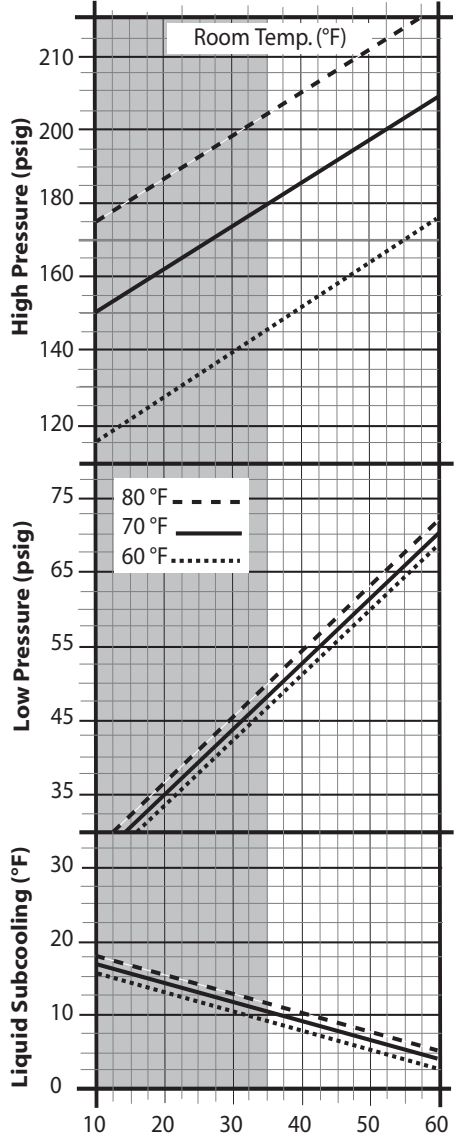

Outdoor Temp. (°F) RH - 50%

■ Shaded area is outside of the Limited Range Heating operation.

REFRIGERANT PIPING INSTALLATION SECTION

FIELD CHARGING

NOTE: If operating superheat is more than 5°F above the chart value, add refrigerant. If below the chart value remove refrigerant. If below the limit line, remove refrigerant.

Example (Using the 12,000 Btuh cooling chart):

1. Suction pressure is 65 psi, which equals 38° F on **The R-22 Scale of the Low-Side Gauge**.
2. Suction line temperature taken at the unit is 70° F. 70° F minus 38° F equals 32° F superheat.
3. Outdoor temperature is 90° F; indoor temperature is 80° F.
4. Intersection of the indoor-temperature and outdoor-temperature lines occur on the 12° F superheat line.
5. Add charge to obtain 12° F superheat.

Instructions:

1. Measure suction pressure and determine evaporator-refrigerant temperature on R-22 scale of low-side gauge.
2. Measure suction-line temperature on suction line of the unit.
3. Measure outdoor and indoor temperatures.
4. Determine from the table what the superheat should be for the indoor and outdoor temperatures. (Example indicates 12° F superheat.)
5. Adjust charge if needed. Be sure unit is running at stabilized condition.

NOTE: For installation of the indoor unit and start-up of the system, please refer to the appropriate installation manual for your indoor product to complete the installation.

STARTING THE UNIT

- Before starting the unit in cool weather, power the system 24 hours before attempting to start.
- Do a final system check using the superheat/subcooling method. Record results on **Test Unit Performance Data** sheet (next page).

- Cooling mode superheat is set with a proper sized piston and charge, using the field charging charts.

- Heating mode superheat is set with a TXV and should be 5°F. When charging a system in heat mode, use the subcool method field charging charts.

- Remove gauge set. Mount all access panels and make sure they are properly secured.
- Make final visual inspection and repair any deficiencies.

(Proceed to the **Sequence Of Operation** on the following pages)

START-UP AND TROUBLESHOOTING TEST PROCEDURE

The Test Unit Performance Data sheet below is provided for use by a qualified service professional. In order for our Technical Service Department to better serve you, please complete and have this information

ready when calling. Make sure to include the Model Number, Serial Number, Date of Installation.

Call our Technical Support Department
@ 1-800-228-9364.

Test Unit Performance Data	
Model Number	Date:
Serial Number	Technician:
	Mode: <input type="text" value="Cooling"/>
Indoor Section	Notes
Evaporator Entering Air - DB	<p><i>Note: Rotary compressors are critically charged systems, do not over charge. Refer to the Charge Table specific to the unit being installed or call the factory. Anti-short cycle protection should be used on systems that use a conventional thermostat.</i></p>
Evaporator Entering Air - WB	
Evaporator Leaving Air - DB	
Evaporator Leaving Air - WB	
Outdoor Section	
Entering Air	
Leaving Air	
Temperature Split	
Operating Pressures	
Compressor Suction - PSIG	
Compressor Discharge - PSIG	
Power Input	
Compressor - Volts	
Compressor - Amps	
OD Fan Motor - Volts	
OD Fan Motor - Amps	
ID Fan Motor - Volts	
ID Fan Motor - Amps	
Total Volts	
Total Amps	
Temperatures - Degrees F°	
Compressor Suction	
Compressor Discharge	
Liquid Out Cond.	
Liquid before Expansion	
Suction out Evaporator	
Capacity Calculations	
DB - Temp Split at evap.	
Test Summary	
Compressor Superheat	
Sub Cooling	

Save this information for future servicing. In the event there is a problem with the unit. Perform the test again (if possible) and have both sets of data ready when calling for assistance.

MULTI-ZONE CONDENSER SEQUENCE OF OPERATION

EMI America Series multi-zone heat pump condensers are designed to operate with EMI America Series indoor air handlers. Both the condenser (*outdoor unit*) and evaporator (*indoor unit*) have a high Volt service connection. Each is to be independently connected to the electrical service panel. (*See the unit name plate for the correct breaker type and size*). The outdoor and indoor units are also connected to each other through a low Volt interconnect wiring. A 24V transformer located in the indoor unit provides the low Volt power source.

The S2HA is a limited range heat pump that will provide comfort cooling or heat pump operation operate at an outdoor temperature range between 35°F and 115°F for cooling, 35°F and 75°F for (*heat pump*) heating. The outdoor unit is equipped with a thermostat that will switch off the condenser when temperature falls below 35°F. For heat pump mode the condenser operation will cease and then switch on the indoor electric heat. For cooling mode, condenser operation will cease.

The S2HA limited range heat pump condensers are designed to operate as a single stage cooling, two stage heating unit. For full operation the unit should be matched with an appropriate EMI indoor unit with electric heat and unit mounted controls or a wall mounted thermostat.

For two stage heating operation the indoor unit must be equipped with an electric strip heater.

See the instruction manual for the indoor unit on the selection of the proper thermostat for the system.

▲▼ Condenser Operation:

The transformer located in the indoor unit provides 24V, low-Volt control power to the condenser (*outdoor unit*). This can be measured across low-Volt terminals "R" and "C".

Heat pump condensers utilize a reversing valve to provide reverse cycle operation. Therefore the outdoor unit will act as either a condenser or an evaporator thereby providing comfort cooling or heating to the indoor space. The reversing valve is energized in cooling. Should the valve fail to actuate, the system will default to the heating mode of operation.

▲▼ Cooling operation, Multi-zone Heat Pump:

Cooling mode operation requires that the control (either unit mount or remote wall mount thermostat) make a connection between low-Volt terminals "R" and "Y" along with "R" and "O". When the indoor control is placed in cooling mode, with the set point temperature below the room temperature, the reversing valve will energize (*R & O*) along with the compressor and outdoor fan (*R & Y*). When the indoor control is satisfied and the room temperature falls below the set temperature, the compressor and fan will de-energize. The EMI indoor unit is equipped with an anti-short cycle timer (*ASCT*) will prevent the compressor from re-starting for three minutes.

When the outdoor temperature falls below 35°F, compressor operation will cease.

▲▼ Heating operation, Multi-zone Heat Pump:

Heating mode operation requires that the control (either unit mount or remote wall mount thermostat) make a connection between low-Volt terminals "R" and "Y" only. When the indoor control is placed in heating mode, with the set point temperature above room temperature, the compressor and outdoor fan (*R & Y*) will energize. When the indoor control is satisfied and the room temperature rises above the set temperature, the compressor and fan will de-energize. The EMI indoor unit is equipped with an anti-short cycle timer (*ASCT*) will prevent the compressor from re-starting for three minutes.

MULTI-ZONE CONDENSER SEQUENCE OF OPERATION

When the outdoor temperature falls below 35°F, compressor operation will cease. At that point the unit will switch on the indoor units electric heater to assume the heating demand, (second stage of heat).

Note: For full operation the indoor unit must have an electric heater.

S2HA LOW VOLT INTERCONNECT DIAGRAMS

WLHA Wall unit Heat Pump Applications

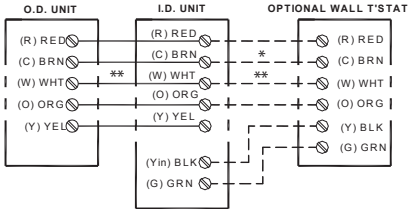

* - Some thermostats do not use a "C" terminal
** - Electric heat option

CAHB HEAT PUMP LOW VOLTAGE INTERCONNECT DIAGRAM

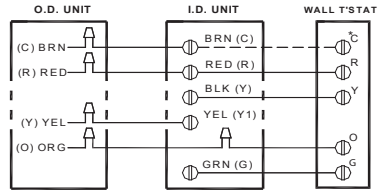

* SOME T'STATS MAY NOT HAVE A "C" TERMINAL
--- OPTIONAL

Refer to the indoor unit for the proper low Volt interconnect wiring.

OPERATION AND MAINTENANCE

The EMI America Series outdoor section is the compressor bearing unit of the system. It operates at the command of the indoor section or room thermostat. Therefore, the operation will be described in the manual pertaining to the indoor section. The S2HA will cease compressor operation at 35°F outdoor temperature. If in heating mode, the electric heat will take over when the compressor ceases operation.

EMI units are designed and constructed for reliability and long life with minimal maintenance. You can assure peak operating efficiency by regularly inspecting for free air passage into and through the coil. If debris collect on the air coil, it should be cleaned by "back-flushing" with a spray of water or vacuuming. **TURN OFF POWER SUPPLY FIRST.** Outdoor units may be cleaned or waxed if desired. Use a non-abrasive car wax.

Panels should remain on the unit at all times. Service should be performed by a QUALIFIED service agency only.

SPECIFIC CHANGES

All EMI products are subject to ongoing development programs so design and specifications may change without notice. Please consult the factory for more information.

GENERAL RECOMMENDATIONS

Do not charge the **straight cool** units on cold days unless weighing in the charge. The **heat pump** systems may be charged in heat cycle between 35 and 75°F. **These units use a heat cycle TXV and cannot be charged to superheat; use weight or subcooling method only.**

Charging should be done with a dial-a-charge or weighed in with a scale.

NOTE: For more information, please visit our web-site at www.enviromaster.com or call 1-800-228-9364.

S2HA DIMENSIONS AND SPECIFICATIONS

NOTE: All EMI products are subject to ongoing development programs so design and specifications may change without notice.

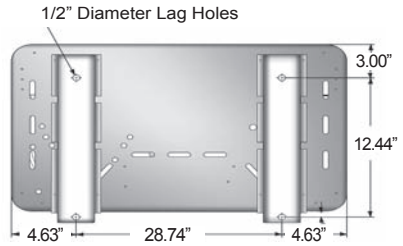
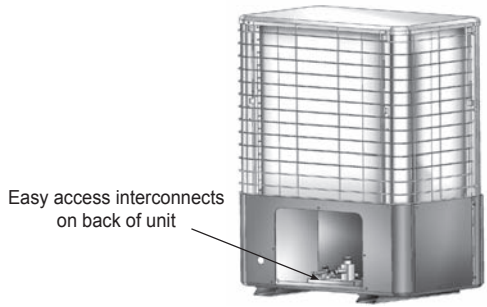
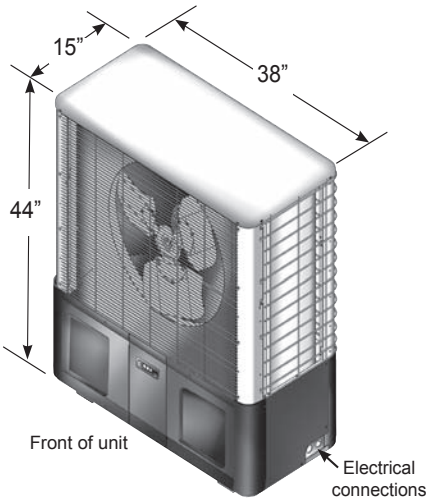

S2HA ELECTRICAL SPECIFICATIONS

MODEL (1)	VOLTS/HZ/PHASE	FAN		COMPRESSOR 1		COMPRESSOR 2		TOTAL AMPS	MIN. CIR. AMPS (2)	HACR BRKR
		RLA	HP	RLA	LRA	RLA	LRA			
9900	208-230/60/1	1.8	0.33	3.4	23	3.4	23	8.6	9.5	15
2200	208-230/60/1	1.8	0.33	4.3	27	4.3	27	10.4	11.5	15
9200	208-230/60/1	1.8	0.33	3.4	23	4.3	27	9.5	10.6	15

(1) Circuit Designators: 9 = 9,000 Btuh • 2 = 12,000 Btuh (ex. - Model 9200 consists of one 9,000 Btuh compressor and one 12,000 Btuh compressor)

(2) Always refer to the rating plate for Minimum Circuit Ampacity on all multiple compressor units.

Model#	S2HA PIPING SPECIFICATIONS		SOUND DATA	SHIPPING WEIGHT
	Line Sizes			
	Liquid	Suction	dBA	Lbs.
9900	1/4"	1/2"	64	159
2200	1/4"	1/2"	65	197
9200	1/4"	1/2"	65	187



ARI Standard
210/240 UAC



ARI Standard
210/240 UHP



S2HA SYSTEM PERFORMANCE

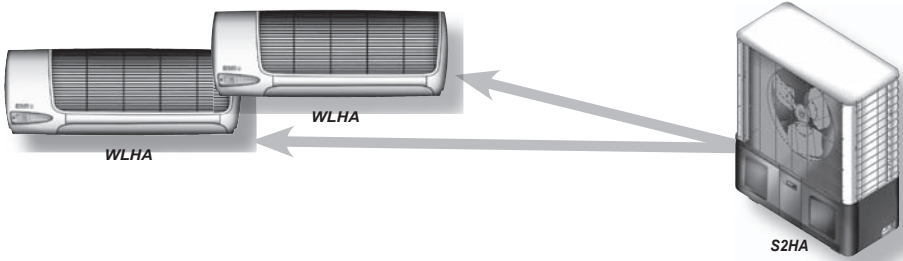

S2HA / WLHA SYSTEM PERFORMANCE

MODEL		COOLING				HEATING	
S2HA (Outdoor)	Indoor Units	Btuh	SEER	SHR	EER	Btuh	C.O.P.
9900	WLHA09 + WLHA09	18,600	13.0	.80	12.2	16,000	3.3
2200	WLHA12 + WLHA12	22,600	13.0	.72	11.9	20,400	3.3
9200	WLHA09 + WLHA12	20,600	13.0	.76	12.0	18,200	3.3

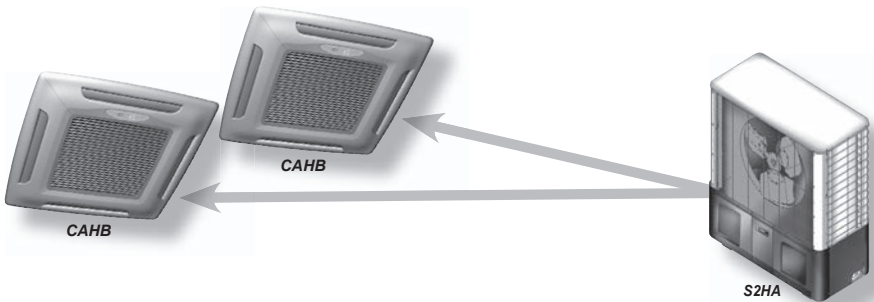

S2HA / CAHB SYSTEM PERFORMANCE

MODEL		COOLING				HEATING	
S2HA (Outdoor)	Indoor Units	Btuh	SEER	SHR	EER	Btuh	C.O.P.
9900	CAHB12 + CAHB12	18,600	13.0	.79	11.7	15,700	3.1
2200	CAHB12 + CAHB12	22,600	13.0	.75	11.6	20,200	3.2
9200	CAHB12 + CAHB12	20,600	13.0	.77	11.6	18,000	3.1

