

LockMaster™

Sliding Gate Opener User's Manual

Model:

DSR 600/1000



- ★ Please read and follow all warnings, precautions and instructions before installation and use
- ★ Periodic checks of the operator are required to ensure safe operation.
- ★ For residential use only
- ★ Save this manual

Table of Contents

General Safety	2
Preparation for Installation	3
Parts List	4
Optional Accessories Part List	5
Technical Specifications & Feature	6
Installation Overview	6
Installation of the Opener	7
Manual Operation	8
Fit The Rack	8
Installation of Magnets for Limit Switches	9
Connecting of Power Supply	10
Connecting of the Control Board	11
Setting of the Control Board	12
Test the reversing sensitivity	14
How to learn or erase the remote	14
How to use the remote to control the opener	14
Trouble Shooting	15
Maintenance	16

Thank you for purchasing DSR 600/DSR 1000 sliding gate opener. We are sure that the products will be greatly satisfying as soon as you start to use it.

The product is supplied with a user's manual which encloses installation and safety precautions. These should be read carefully before installation and operation as they provide important information about safety, installation, operation and maintenance. This product complies with the recognized technical standards and safety regulations.

General Safety

⚠ WARNING! An incorrect installation or improper use of the product can cause damage to persons, animals or properties.

- Scrap packing materials (plastic, cardboard, polystyrene etc.) according to the provisions set out by current standards. Keep nylon or polystyrene bags out of children's reach.
- This product was exclusively designed and manufactured for the use specified in the present documentation. Any other use not specified in this documentation could damage the product and be dangerous.
- The factory declines all responsibility for any consequences resulting from improper use of the product, or use which is different from that expected and specified in the present documentation.
- Do not install the product in explosive atmosphere.
- The factory declines all responsibility for any consequences resulting from failure to observe Good Technical Practice when constructing closing structures (door, gates etc.), as well as from any deformation which might occur during use.
- Disconnect the electrical power supply before carrying out any work on the installation. Also disconnect any buffer batteries, if fitted.
- Fit an omnipolar or magnetothermal switch on the mains power supply, having a contact opening distance equal to or greater than 3,5 mm.
- Make sure a residual current circuit breaker with a 30mA threshold is fitted before the power supply mains.
- Check that earthing is carried out correctly: connect all metal parts for closure (doors, gates etc.) and all system components provided with an earth terminal.
- Fit all the safety devices (photocells, electric edges etc.) which are needed to protect the area from any danger caused by squashing, conveying and shearing.
- Position at least one visible indication device (Alarm lamp), and fix a Warning sign to the structure.

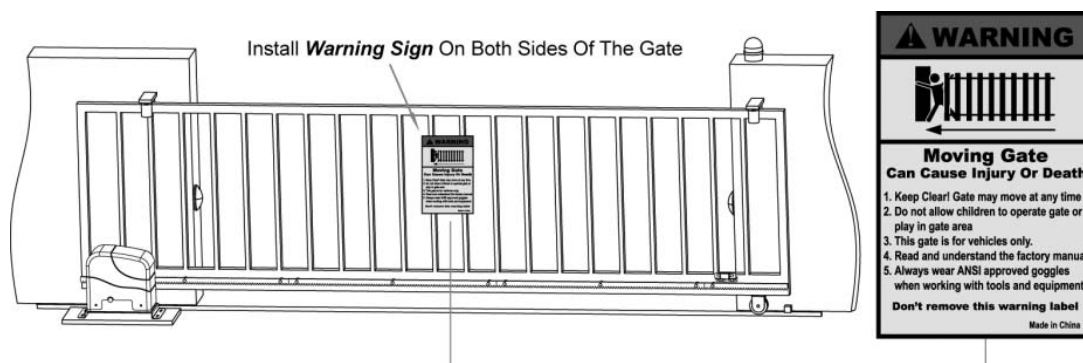

- The factory declines all responsibility with respect to the automation safety and correct operation when other supplier's components are used.
- Only use original parts for any maintenance or repair operation.
- Do not modify the automation components, unless explicitly authorized by the factory.
- Instruct the product user about the control systems provided and the manual opening operation in case of emergency.

- Do not allow persons or children to remain in the automation operation area.
- Keep radio control or other control devices out of children's reach, in order to avoid unintentional automation activation.
- The user must avoid any attempt to carry out work or repair on the automation system, and always request the assistance of qualified personnel.
- Anything which is not expressly provided for in the present instructions is not allowed.
- Before installing the gate opener, check that all moving part as well as the sliding gate is in good mechanical condition, correctly balanced and opens and closes properly.
- Save these instructions for future use.

Preparation for Installation

Before proceeding to your opener installation, check if your gate structure is in accordance with the current standards, especially as follows:

The gate sliding track is linear and horizontal. The wheels are suitable for use. The gate should be mounted and moved freely. Check that the structure is sufficiently strong and rigid, and that its dimensions and weights conform to those listed in the specifications table of this document. Make sure that the gate is plumb and level. The fence posts must be mounted in concrete. The gate does not bind or drag on the ground.

- The gate manual operation can be carried out smoothly along its entire run, and there is no excessive side slipping.
- The opening and closing gate stops are positioned.



WARNING: Remember that control devices are intended to facilitate gate operation, but can not solve problems due to any defects or deficiency resulting from failure to carry out correct installation or maintenance. Take the product out of its packing and inspect it for damage. Should it be damaged, contact your dealer. Remember to dispose of its components (cardboard, polystyrene, nylon, etc.) according to the current prescriptions.

Refer to the following Figures for gate installation.

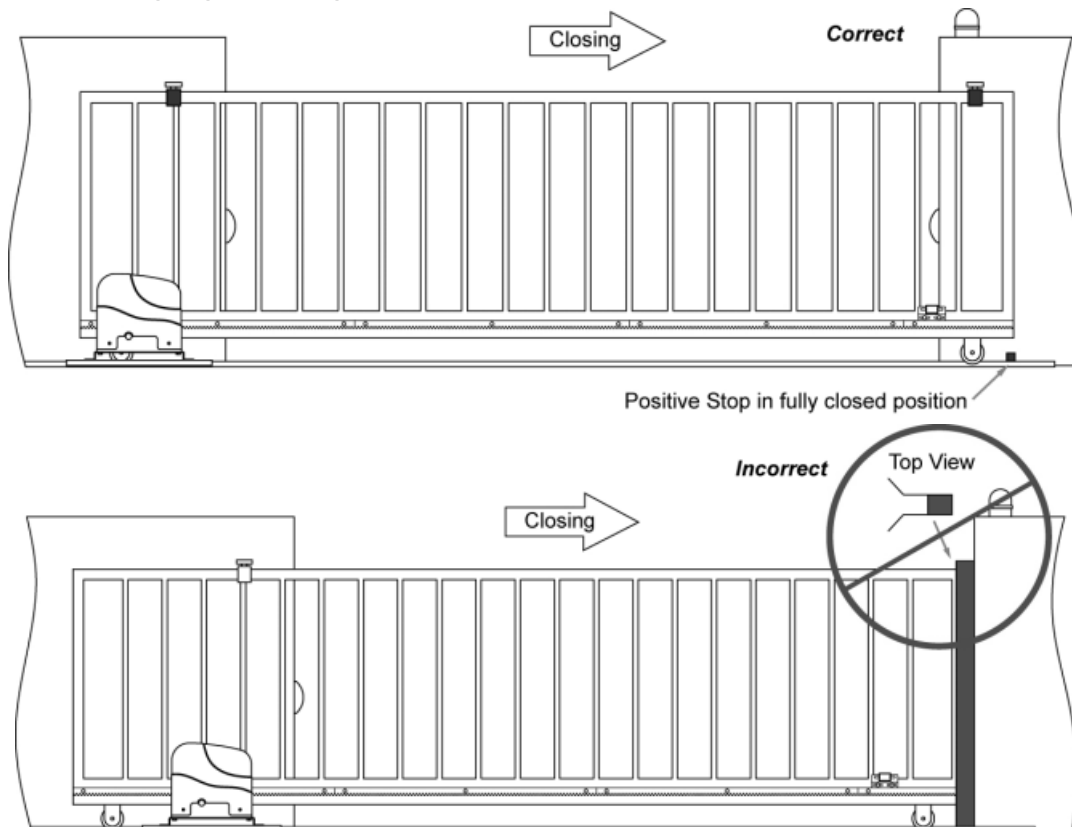

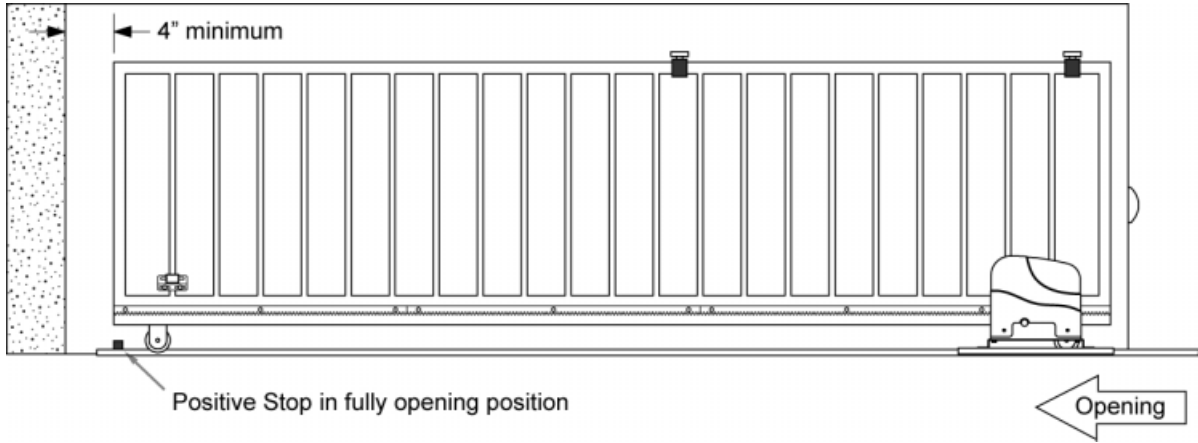

Parts List

 Gate Operator (1 pc)	 Remote Control (2 pcs)	 Anchor Bolt (4 pcs)	 Warning Signs (2 pcs)
	 Release Key (1 pc)	 Base Plate (1 pc)	
 Magnet bracket (2 pcs)	 M8x70 Bolt (4 pcs)	 Φ10 Washer (4 pcs)	 Φ8 Washer (8 pcs)
 Magnet Assembly (2 pcs)	 M8x30 Bolt (4 pcs)	 Φ10 Lock Washer (4 pcs)	 Φ8 Lock Washer (8 pcs)
 M10 Nut (4 pcs)	 M8 Nut (4 pcs)	 Plastic Rack Reinforced with Steel 1005mm×N(pcs) (Optional)	 Plastic Rack Reinforced with Steel 1005mm×N(pcs) (Optional)
 Galvanized Steel Rack 1005mm×N(pcs) (Optional)			

Optional Accessories Parts List

Optional			
 <p>Back up battery (1 set) (LM125)</p>	 <p>Battery emergency charger (1 pc) (LM135)</p>	 <p>2.5" Video Intercom (1 set) (LM162)</p>	 <p>7" Video Intercom (1 set) (LM165)</p>
 <p>Back up battery box(1 pc) (LM130)</p>	 <p>Alarm Lamp (1 pc) (LM140)</p>	 <p>Photocell Beam System (1 set) (LM102)</p>	 <p>Wall push button (1 pc) (LM147)</p>
 <p>Solar Controller (1 pc) (LM117)</p>	 <p>Solar panel (1 pc) (LM109)</p>	 <p>Supporting frame for solar panel (1 pc) (LM115)</p>	 <p>Bracket for solar panel (1 pc) (LM116)</p>
 <p>Keypad (wireless) (1 pc) (LM105)</p>	 <p>Wired Keypad (1 pc)(LM106/24) ID card (LM170)</p>	 <p>Mounting post for keypad (1 pc) (LM107)</p>	 <p>Loop Detector (1 pc) (LM155)</p>
 <p>External Receiver (1 pc) (LM138)</p>			

Technical Specifications & Features

Specifications

- Power supply: 230V/50HZ or 120VAC/60Hz
- Rated input power: 180W for DSR 600 / 350W for DSR 1000
- Gate moving speed: 0.2m/sec
- Max gate weight: 600KGS for DSR 600 / 1000KGS for DSR 1000
- Max torque: 12Nm for DSR 600 / 24Nm for DSR 1000
- Ambient: from -15°C to +40°C; Humidity: max 75%
- Protection class: IP44
- Dimensions: 396mm×190mm×315.5mm

Features:

- Soft start and soft stop
- Midway mode. Quick selection for the gate open/close direction
- Reliable rolling code technology for remote control
- Emergency release key in case of power failure
- Stop/Reverse in case of obstruction during gate opening/closing
- Built in adjustable auto-close (none, 30, 60, 90 seconds)
- Built in motor running limitation: max. 90 sec
- Reliable electromagnetism limit for easy adjustment
- Can be equipped with a wide range accessories

Installation Overview

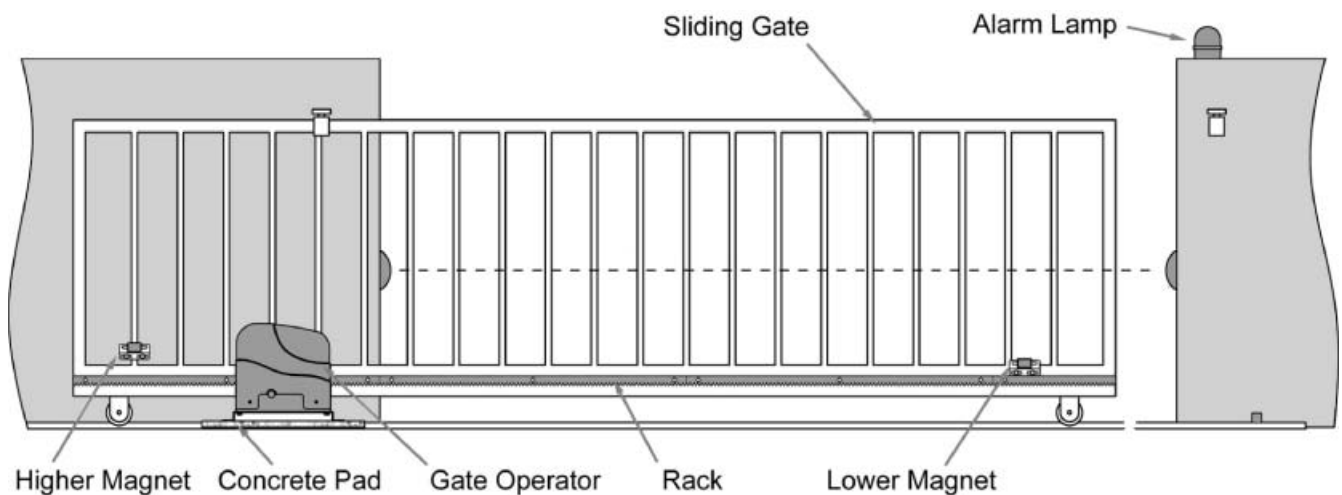

Installation of the Opener

Caution:

- *Be sure that the opener is installed in a horizontal and paralleled position and is properly secured. Improper installation could result in property damage, severe injury, and/or death.
- * Before starting installation, ensure that there is no point of friction during the entire movement of the gate and there is no danger of derailment.
- * Ensure that the *Warning Signs* are present.

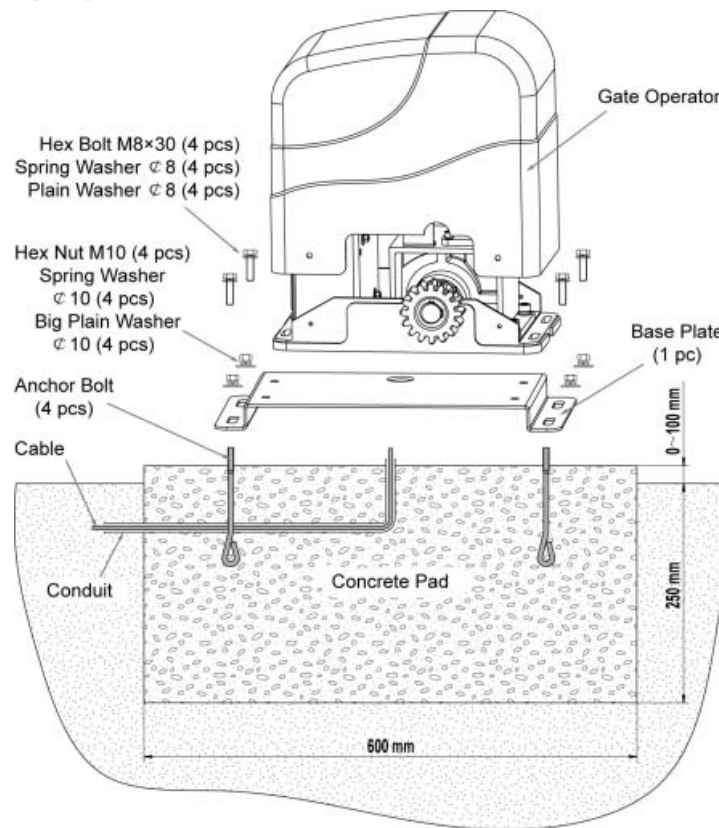

Necessary Tools: The following tools may be necessary to install the Gate opener. You will need screwdrivers, an electric drill, wire cutters and a wire stripper, a socket set, and possibly access to a welder. When install the opener, you should build a concrete pad to support the base plate of opener in order to maintain proper stability.

The installation proceeds are as follows:

1. Dig a hole for a concrete pad which should be approximately 600 x 320 x 350mm (24" x 13" x 14"). It may protrude 100mm (4") above ground and 250mm (10") in depth underground. Increase the pad height if necessary to protect the system from flooding, heavy snow etc.
2. Prepare one or more conduits for the electrical cables before pouring concrete. Remember that cable conduits have to pass through the hole in the base plate.
3. Pour concrete and before it starts to harden, check that it is parallel to the gate leaf and perfectly level.
4. The four anchor bolts must be set into the concrete when it is poured, make sure the position of anchor bolts was placed according to the position of mounting holes on the base plate before concrete become harden.
5. Mount the base plate to the concrete pad.
6. Place the opener onto base plate. Check that it is perfectly parallel to the gate, and then screw the four bolts and washers supplied. It's only temporary installation. Further adjustment will be required when install the rack.

Manual Operation

The opener should be put in the manual (emergency release) position before fitting the rack, installing the opener and limit switch. The process is as follows:

- 1) Take off the rubber stopple.
- 2) Insert the Release Key (provided) and turn it in counter-clockwise 180° to disengage the clutch between the gear shaft and power output. Now the opener is in the manual operation.

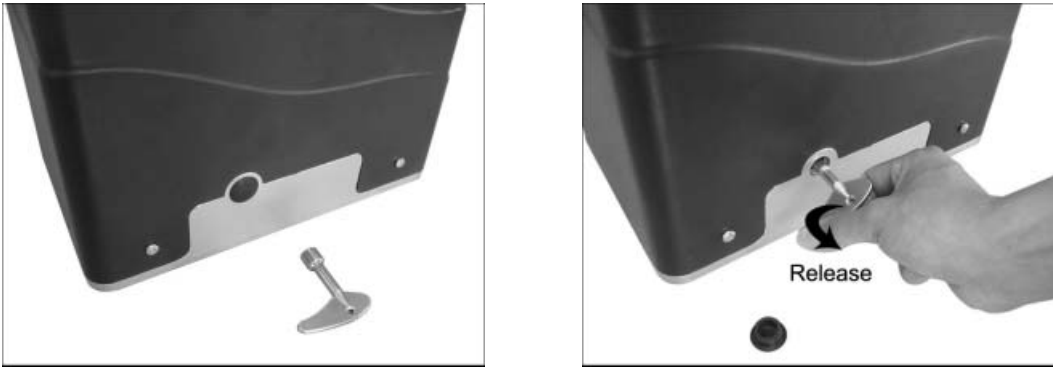

Fit the Rack

There are two kinds of rack available as per your options, which are steel reinforced plastic rack and galvanized steel rack. The galvanized steel rack is usually used for the heavy duty gate.

A. Fit the plastic rack reinforced with steel

1. Start with gate in closed position
2. There are four sections of plastic rack which is one meter length, each section for standard package. (you can order extra rack from dealer if necessary)
2. Put one end of rack section on the gear of opener as a temporary support. Make rack level and mark the rack's mounting holes (**four holes for light duty or six holes for heavy duty**) on the gate.
3. Fit the rack by self-threading screws. This kind of plastic rack is quieter and allows height adjustments to be made even after it has been fixed. Please keep 1.0mm space between the rack and the gear to avoid the weight of the gate leaf effect on the opener.

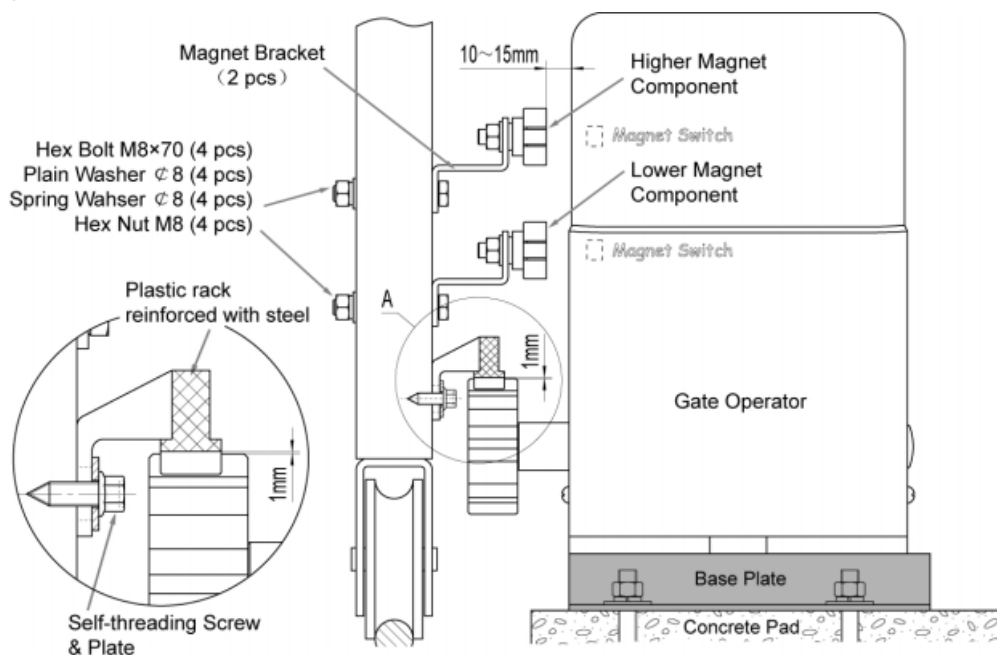

B. Fit the galvanized steel rack

1. Start with gate in closed position
2. There are four sections of steel rack which is one meter length, each section for standard package. (you can order extra rack from dealer if necessary)
2. Put one end of rack section on the gear of opener as a temporary support. Make rack level and mark the rack's mounting holes (**three holes**) on the gate.
3. Weld the rack nut on the gate as mark and connect the rack to the gate using the bolt provided. Before weld, please keep 1.0mm space between the rack and the gear to avoid the weight of the gate leaf effect on the opener.

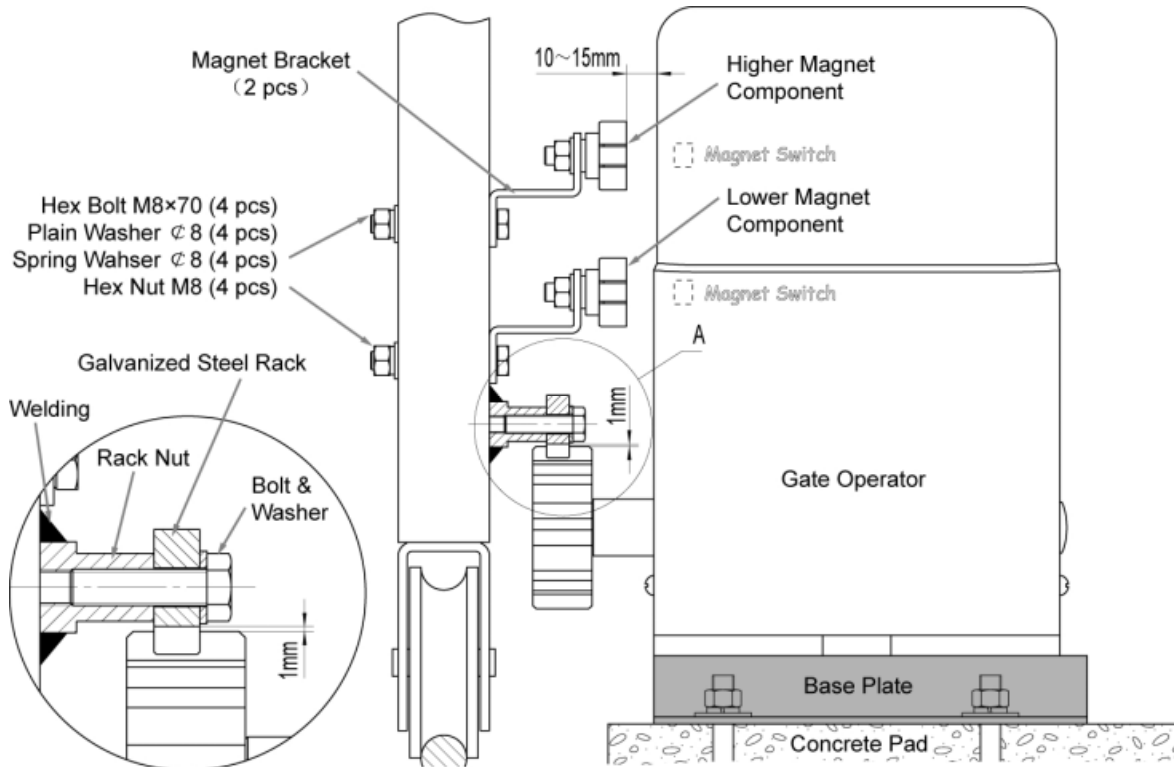

Important:

- * Check that the rack teeth must engage the gear teeth throughout their full thickness. If not, adjust the position of the opener or/and place a few shims between the rack and gate.
4. Manually slide the gate leaf to ensure the rack is proper on the gear of opener, weld the second nut.
 5. Repeat same steps of first rack section to install the rest rack sections until proper length is reached.
 6. Cut away any excess of the rack (Note: rack length must be longer than actual travel of the gate to accommodate limit switch brackets on each gate side.)
 7. Thoroughly fasten the four nuts as well as spring washers onto anchor bolts tightly, enabling the opener is firmly secured on the concrete pad during the whole gate travel.

Installation of Magnets for Limit Switches

Before install Magnets, make sure the gate opener is put in manual operation. (the clutch connected with gear shaft is disengaged) and the mains power supply is disconnected.

Position the two Magnets approximately on the gate and move the gate manually to secure them in place.

Fit magnets bracket

Push the gate fully closed by hand. Locate and install the magnet bracket so that the opener will stop at the

desired close position when the close limit switch approaches it.

Push the gate fully open by hand. Locate and install the magnet bracket so that the opener will stop at the desired open position when the open limit switch approaches it.

The higher magnet component must be installed at left side and lower magnet component must be installed at right side from the view inside of property. Finally adjust the magnet to the proper position by moving the gate with the motor. The magnet should be .39 - .59 “away from the magnetic limit switch. If it is too far away, the switch will fail to work. The distance between the magnet and the opener should be 1/2” (12mm) with the opener cover on. Adjust the position of the magnet until the positions of the opening and closing meet the requirement.

Connecting Of Power Supply

The power supply cord should be at least H05R1V-F, 3×0.75mm².

Connect the live wire, neutral wire and earth wire to the “L”, “N” and “PE” terminal respectively. It is strongly recommended that an emergency stop switch is installed in the electrical system which can be used in case of the remote control failure.

You can connect the switch by the following steps:

1. Cut off the wire which has been connected between terminal 4 and 5 in factory to deactivate the existed short circuit of terminal 4 and 5.
2. Solder the two wires to the terminals of the switch respectively.

NOTE: The power supply cord is not included in the package.

NOTE: Make sure a residual current circuit breaker with a 30mA threshold is fitted before the power supply mains.

NOTE: The protection class of the emergency stop switch should be at least IP44.

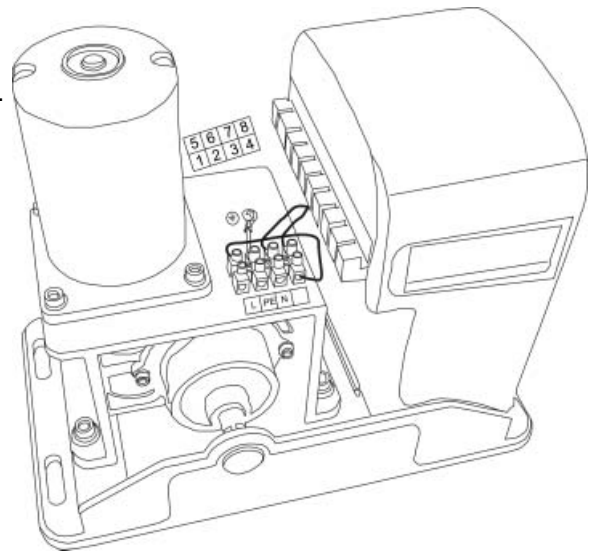

Connecting Of The Control Board

CONTROL BOARD

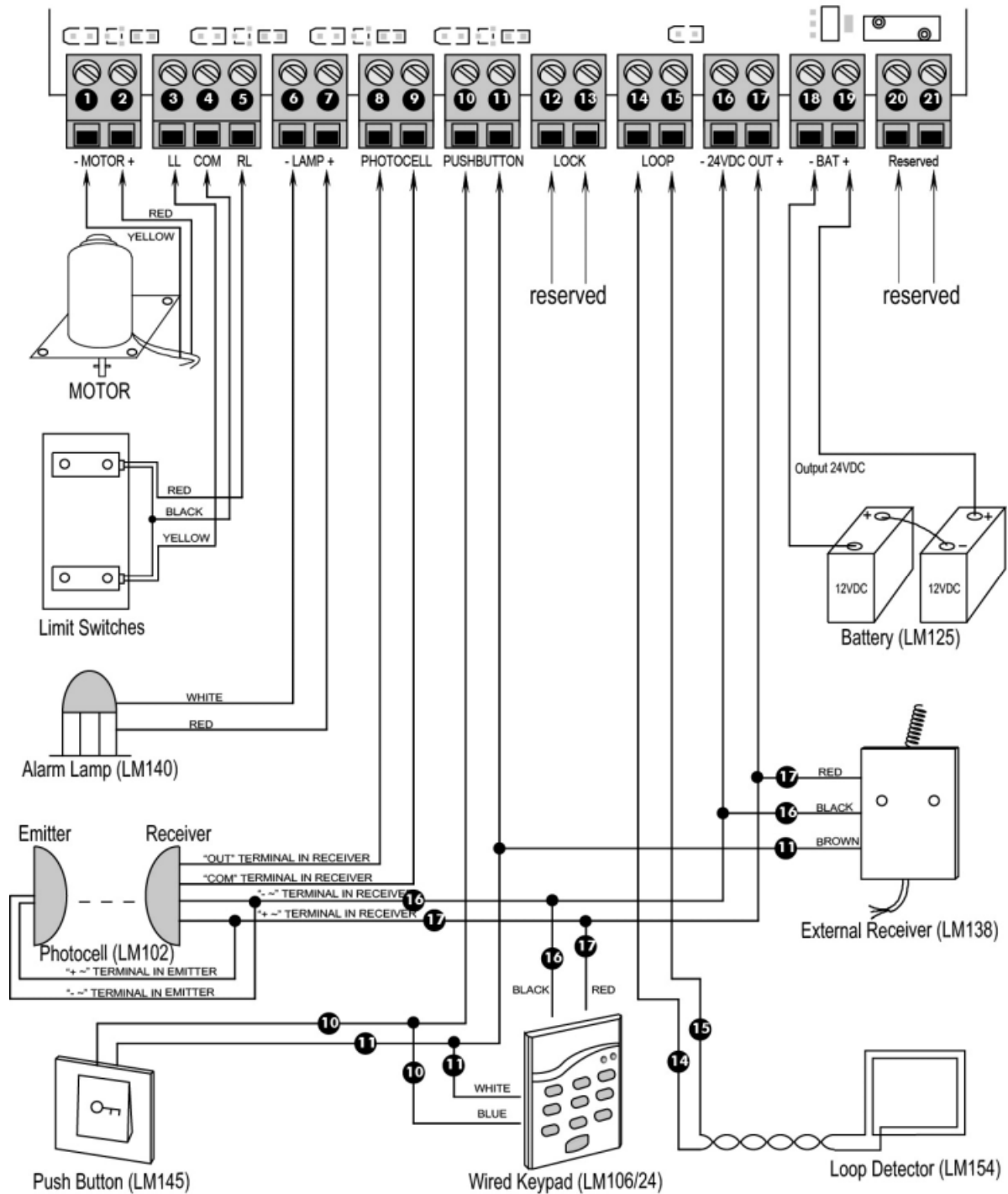

1. Motor

The **YELLOW** wire of the motor should be connected into the “1” terminal.

The **RED** wire of the motor should be connected into the “2” terminal.

2. Limit Switches

The **YELLOW** wire of the limit switches should be connected into the “3” terminal.

The **BLACK** wire of the limit switches should be connected into the “4” terminal.

The **RED** wire of the limit switches should be connected into the “5” terminal.

3. Alarm Lamp (24VDC)

The **WHITE** wire of the alarm lamp should be connected into the “6” terminal.

DIP Switch #1–#2: Running time of the motor in Midway Mode

DIP Switch #1: ON – 2 Seconds OFF – 0

DIP Switch #2: ON – 4 Seconds OFF – 0

NOTE: The midway mode function would be disabled if both DIP switches are turned off. Factory default setting is disabled.

E.g.  → Running time of the opener in pedestrian mode is 2+4=6 seconds.

DIP Switch #3–#5: Fine adjust the soft stop period of the motor

DIP Switch #3: ON – 1 Second OFF – 0

DIP Switch #4: ON – 2 Seconds OFF – 0

DIP Switch #5: ON – 4 Seconds OFF – 0

NOTE: Every time you restart the gate opener after power off, you should use the access control device (such as remote, push button and etc.) to operate the gate opener to run for a complete opening cycle and a complete closing cycle to get the full opening time and the full closing time. You would achieve the soft stop in your next opening/closing cycle. Factory default soft stop time is 0 Second. You can turn the DIP switches on/off to fine adjust the soft stop time to meet your actual needs.

E.g.  → The soft stop period of the motor is 1+2=3 seconds.

DIP Switch #6–#7: Auto close time of the gate opener

DIP Switch #6: ON – 30 Seconds OFF – 0

DIP Switch #7: ON – 60 Seconds OFF – 0

NOTE: The auto close function would be disabled if both DIP switches are turned to off (factory default setting).

E.g.  → Auto close time of the gate opener is 30+60=90 seconds.

DIP Switch #8: Left/Right open

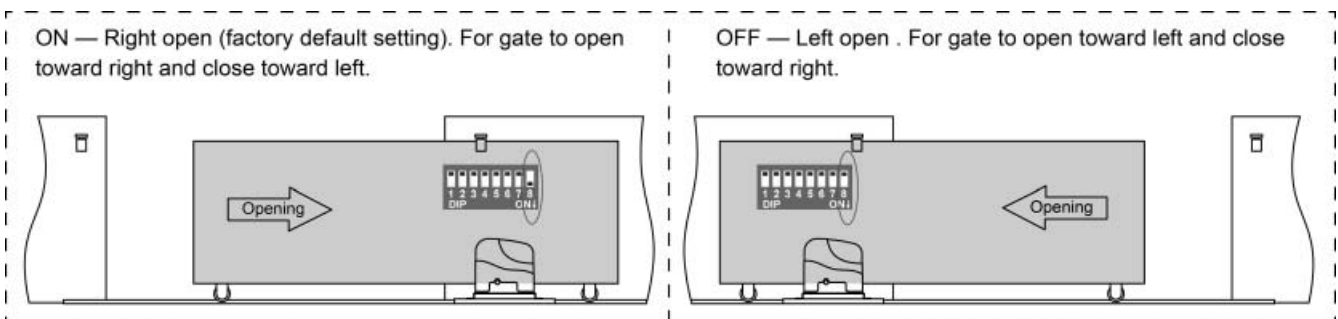

2. Potentiometers

Potentiometer A and B are used to adjust the stall force of the gate opener. Both two potentiometers of factory default force have been set to at 15:00 o'clock.

Turn the potentiometer clockwise to increase the stall force.

Turn the potentiometer counter-clockwise to decrease the stall force.

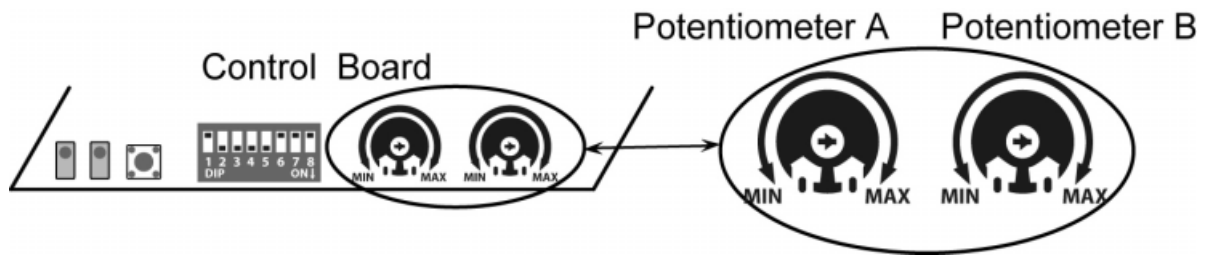

Test the reversing sensitivity

For the sake of safety, it is very important to test the reversing sensitivity as soon as the control board set is finished.

The reversing sensitivity adjustment is inverse correlation with stall force adjustment in potentiometer A and B. In other word, the stall force level is higher; the reversing sensitivity level is lower.

Put an immobile object along the gate path, and then operate the gate to strike it during the open and close cycles. The gate must reverse as soon as object is struck with it. If the gate doesn't reverse, please increase the reversing sensitivity by turning the potentiometer in counter-clockwise direction. (Turning the stall force potentiometer toward to MIN position to increase the reversing sensitivity)

Note 1: If the sensitivity setting is too higher, the gate will stop or reverses very easy by itself while there is little obstruction or resistance such as strong wind or heavy snow sometimes.

Note 2: Always check the gate reversing function every each time of control board set or restart after power off.

How to learn or erase the remote

Learn the remote

Press and release the learn button, the **REM LED** light will be on, then press the key in the remote twice in 2 seconds, the **REM LED** light will flash for 4 seconds. Now the remote has been learnt successfully.

Erase all the remote codes

Press and hold the learn button until the **REM LED** light is off. Now all remote codes have been erased.

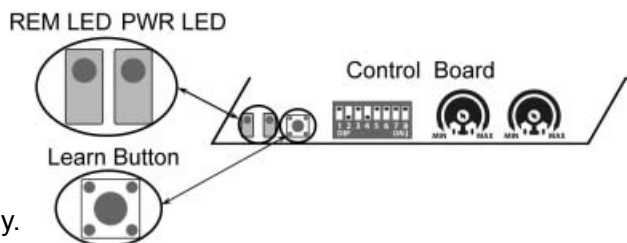

How to use the remote to control the opener

Key A is used to operate the opener to work alternately (open-stop-close-stop-open).

When the Pedestrian Mode function is enabled, **Key B** is used to achieve the Pedestrian Mode function (open the gate for the pre-setting time). When the Pedestrian Mode function is disabled, the opener works alternately (open-stop-close-stop-open) by pressing **Key B**.

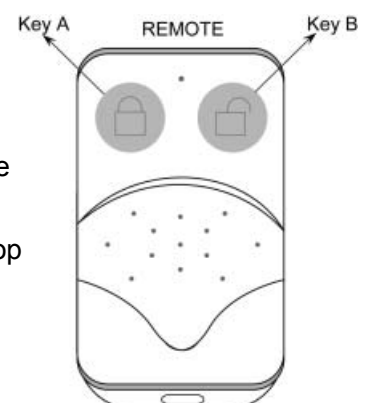

Troubleshooting

Have a multimeter to check voltage and continuity. Use caution when checking high voltage terminals.

Symptom	Possible Solution(s)
The opener does not run. Power LED is OFF.	<ol style="list-style-type: none"> 1. Make sure that the power cord is properly plugged into the mains outlet. 2. Check if the output voltage of the transformer is 24VAC. If the voltage measures 0, the transformer may be overheated or damaged. Turn power off and allow board to cool for several minutes then reset. Replace the transformer if the symptom still exists. 3. Check the fuse in the control board. Replace the fuse if it was burnt out. 4. Check the control board. Replace the control board if necessary.
The opener does not run. Power LED is ON.	<ol style="list-style-type: none"> 1. Check to be sure the beam is not blocked if a photocell is used as a secondary entrapment prevention device. If a photocell is not used, terminal 8 should be shorted with terminal 9 by a jumper wire. 2. Check the motor. Release the clutch then disconnect the wires of the motor from terminal 1 and 2. Connect the wires to the terminal 16 and 17 directly, the motor should run, and then exchange the wires, the motor should run in the opposite direction. If the motor runs in both directions, please check the other parts listed below. 3. Check the limit switches. Use a jumper wire to short terminal 4 with terminal 3 and 5, and then use a keying device to operate the opener, replace the higher limit switch if the motor couldn't run in clockwise direction, and replace the lower limit switch if the motor couldn't run in counter-clockwise direction. 4. Replace the control board if the motor runs in all steps above.
Remote control does not work.	<ol style="list-style-type: none"> 1. The indicator light of remote control is not on. Check the battery in your remote control. Replace the battery if necessary. 2. The distance you use the remote is too far away from the opener. Try it again closer. 3. Remote control is not suitable for receiver. After making sure the codes are correct, erase remote controls and then re-program the codes in the device. 4. Replace the control board.
The gate starts but it is immediately stop or reverse	<ol style="list-style-type: none"> 1. Check that the clutch is adjusted properly and is not slipping. 2. The opening force or closing force is adjusted too small. Turn the Potentiometer A to increase the force. 3. Disconnect the gate from the gate opener and check that the gate slides freely without any binding. 4. Replace the control board.
The gate opens, but stops and will not return.	<ol style="list-style-type: none"> 1. Please note the two magnet brackets (fixed plate) are different: one is higher and another is lower. Please try to exchange the two brackets position. 2. Please try to exchange the limit switch wires CL (close) and OP (open).

	3. Maybe the magnet position was installed in the middle so it inducts both switches. Adjust the magnet higher or lower.
The gate can open, but fails to close.	<ol style="list-style-type: none"> 1. Photocell is obstructed. Remove obstruction. 2. The limit switch is failed. Use a jumper wire to short terminal 4 with terminal 3 and 5, and then use a keying device to operate the opener, replace the higher limit switch if the motor couldn't run in clockwise direction, and replace the lower limit switch if the motor couldn't run in counter-clockwise direction. 3. Replace the control board.

Maintenance

Every six months check the following items for proper operation of the unit.

- * Lubricate shafts and sprockets.
- * Keep opener clean at all times.
- * Check and tighten anchors bolts.
- * Check for loose or corroded wire
- * Ensure the opener is well earthed, and correctly terminated.
- * Always check the Stop/Reverse in case of obstruction function when performing any maintenance. If this function can't be made operable, remove this opener from service until the cause of the malfunction is identified and corrected.



According to Waste of Electrical and Electronic Equipment (WEEE) directive, WEEE should be separately collected and treated. If at any time in future you need to dispose of this product please do NOT dispose of this product with household waste. Please send this product to WEEE collecting points where available.

www.WholesaleGateOpener.com
 7106 S 220th St, Kent WA 98032 USA
sales@WholesaleGateOpener.com
 ©2010-2012 LockMaster All Rights Reserved