

Silverpak 23D Plus

Integrated NEMA 23 Motor and Drive With Encoder option



Silverpak 23D Plus

User Manual And Commands Guide

Version 1.00

Thank you for purchasing the Silverpak 23 DOP or Silverpak 23 DEP Integrated Motor and Driver. This product is warranted to be free of manufacturing defects for one (1) year from the date of purchase.

PLEASE READ BEFORE USING

Before you start, you must have a suitable DC power supply suitable for the motor. The power supply voltage must be between 4 times and 20 times the motor's rated voltage.

DISCLAIMER

The information provided in this document is believed to be reliable. However, no responsibility is assumed for any possible inaccuracies or omissions. Specifications are subject to change without notice.

Lin Engineering reserves the right to make changes without further notice to any products herein to improve reliability, function, or design. Lin Engineering does not assume any liability arising out of the application or use of any product or circuit described herein; neither does it convey any license under its patent rights, nor the rights of others.

Silverpak 23D/DE Plus User Manual

Product: Silverpak 23 DOP and Silverpak 23 DEP
Version: 1.00
Date: 5/6/2009

Version History		
Version	Date	Description of Changes
1.00	5/6/2009	New user manual

Table of Contents

1	FEATURES.....	5
	POLE DAMPING TECHNOLOGY™	5
	SILVERPAK 23DE PLUS – ENCODER FEATURES.....	5
	DEFAULT SETTINGS	5
2	ELECTRICAL SPECIFICATIONS.....	6
3	OPERATING SPECIFICATIONS	6
4	MECHANICAL SPECIFICATIONS	7
	DIMENSIONS.....	7
	DIMENSIONS OF SILVERPAK 23DE WITH ENCODER	8
5	PIN ASSIGNMENTS	8
6	CONNECTION SPECIFICATIONS.....	11
	CONNECTING THE SILVERPAK 23D PLUS TO YOUR PC VIA USB.....	12
	CONNECTING THE SILVERPAK 23D PLUS TO YOUR PC VIA RS232	13
	RESISTOR VALUES FOR THE OPTO SUPPLY	13
7	CONFIGURING THE SETTINGS	16
	CONNECT TO LIN DRIVER GUI FOR SETTING PARAMETERS	16
8	BASIC OPERATION	18
9	TROUBLESHOOTING	21
10	APPENDIX	22
	RECOMMENDED CABLE CONFIGURATIONS: DC SUPPLY TO DRIVER	22
	STEP RISING/FALLING DETECT:	23
	AMPS RMS VS. AMPS PEAK.....	25

1 **FEATURES**

- NEMA Size 23, 2 Phase, 1.8° Bipolar Step Motor w/ Built-In Microstepping Driver
- Operates from +12 to 75 VDC
- Software selectable run currents from 0.1 to 5.0 Amp Peak (in 0.05 Amp increments)
- Software selectable hold currents from 0 to 5.0 Amp Peak (in 0.05 Amp increments)
- Step Resolutions from Full step, 2x, 4x, 5x, 8x, 10x, 16x, 25x, 32x, 50x, 64x, 125x, 128x, 250x, 256x Microstepping
- Four Selectable Damping modes for smooth motion
- No low minimum inductance (any NEMA 23, 1.8° step motor can be selected)
- Step sensing on the rising or falling edge of step pulse input
- Direction switching – to change first powered on direction of rotation
- Enable active high or low – to allow unit to be enabled with a high or low signal
- Smooth motion
- Three optically isolated control inputs (step, direction, disable)
- Inputs are sinking inputs, maximum current input is 15mAmps
- Pole Damping Technology™ integrated within driver board

Pole Damping Technology™

Pole Damping Technology™ (PDT) enhances step motor performance by dampening each full step in order to create a more accurate and smooth motion profile. Microstepping the step motor will optimize Pole Damping Technology™. PDT outputs the correct amount of run and hold currents to the motor, at the right time. Thus, it will overcome the step motor's natural tendency to want to forcefully pull towards the full step ON position.

Silverpak 23DE Plus – Encoder Features

- 32-1250 cycles per revolution (CPR)
- 128 to 5000 pulses per revolution (PPR)
- 2 Channel Quadrature
- TTL Squarewave Outputs and optional index (3rd Channel)
- E2 US Digital Encoder

Default Settings

Default Settings of the Silverpak 23D or DE Plus	
Direction of rotation	Counterclockwise
Step Resolution	8x step (3200 steps/rev)
Run Current	Motor's rated current or up to 5 Amps Peak if motor is rated for 5 or higher.
Holding Current	0.5 Amp/Phase
Smoothness setting	2
Step signal sensing	Senses on the Rising Edge or positive edge
Disable Active	Low or 0V signal to disable unit

Table 1: Default settings

2 ELECTRICAL SPECIFICATIONS

Power Supply Requirements

Voltage +12 VDC to 75 VDC

Driver

Peak Current: 0.1 to 5.0 Amps Peak
Baud rate: 57600 bps

Motor Specifications

NEMA Size 23

Holding Torque:

DOP-5718X-XX 100 oz-in

DOP-5718M-XX 182 oz-in

DOP-5718L-XX 294 oz-in

Steps per Revolution (1.8° Motor)

200, 400, 800, 1000, 1600, 2000, 3200, 5000, 6400, 10000, 12800,
25000, 25600, 50000, 51200

Microstepping: Full step, 2x, 4x, 5x, 8x, 10x, 16x, 25x, 32x, 50x, 64x, 125x,
128x, 250x, 256x

I/O Specifications

3x Optically Isolated Inputs (step, direction, disable) capable of
15mAmps max

3 OPERATING SPECIFICATIONS

Maximum Step Frequency:

5 MHz

Operating Temperature*:

-20°C to 85°C measured at the heat sink
-20°C to 100°C measured at the motor case

Duty cycle:

100% as long as temperatures do not
exceed 75°C on the heat sink and 90°C on
the motor case.

* Lin Engineering integrated motor and drive products are designed and fully tested to withstand the rated operating temperature ranges as long as max temperature is not exceeded on the motor and heatsink.

WARNING: Driver portion may malfunction if the heatsink temperature exceeds 85°C. Motor may burn if it exceeds 100°C. Please use correct heat dissipation methods to avoid high temperatures, like mounting the motor to a large aluminum frame, using a fan or other methods for better air circulation for convection.

Logic Timing

Minimum Step Pulse Width 100 nanoseconds

Minimum Step Low Time 100 nanoseconds

Maximum Power-Down Recovery Time 20 milliseconds

4 MECHANICAL SPECIFICATIONS

Motor Front Shaft Extension Length: Standard length is 0.81"

Motor Shaft Diameter: Standard shaft diameter is 0.25"

Overall Body Length (A)

DOP-5718X-XX	(2.65")
DOP-5718M-XX	(3.16")
DOP-5718L-XX	(4.03")

Dimensions

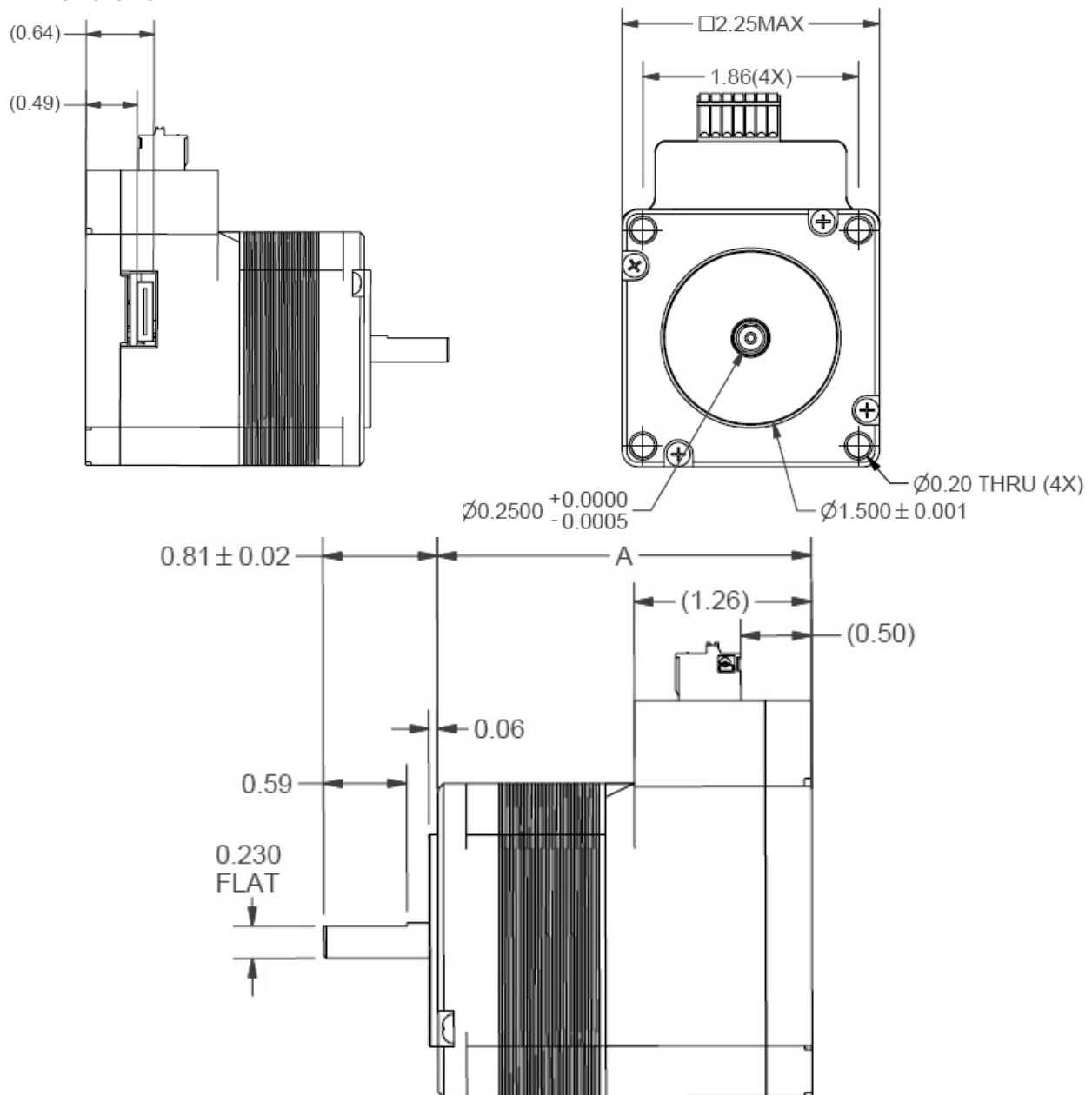

Figure 1: Dimensions Diagram

Dimensions of Silverpak 23DE with Encoder

(Encoder version will be available in July 2009)

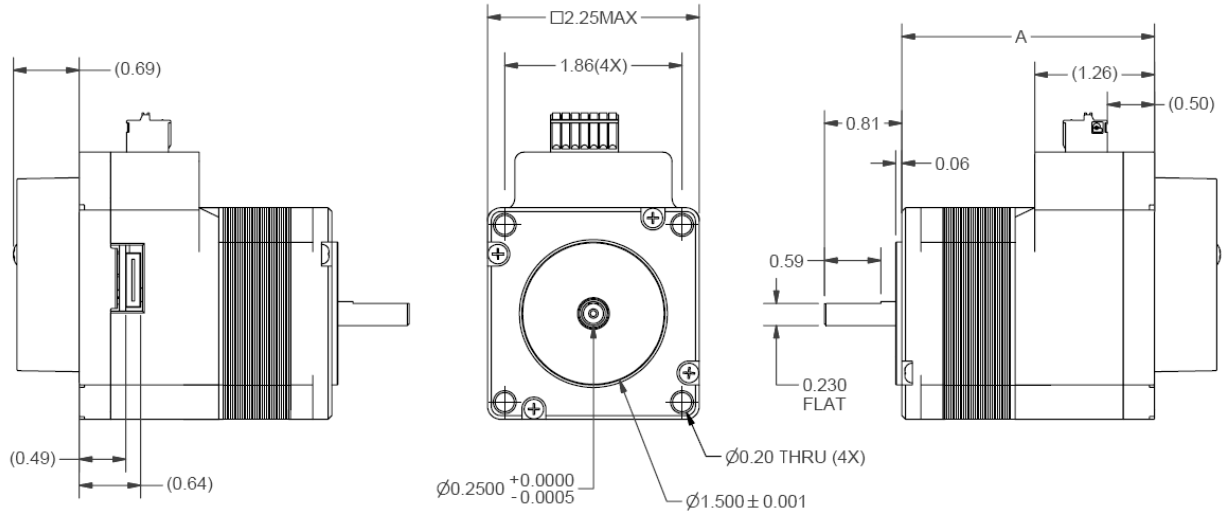

Figure 2: Encoder drawing

5 PIN ASSIGNMENTS

Along with the Silverpak 23D Plus unit, you should've received the following cables.

Lin p/n: 090-00214



Figure 3: 5-wire cable for step, direction, disable, 5V output & opto supply

Lin p/n: 090-00215



Figure 4: 2-wire cable for Power & Ground

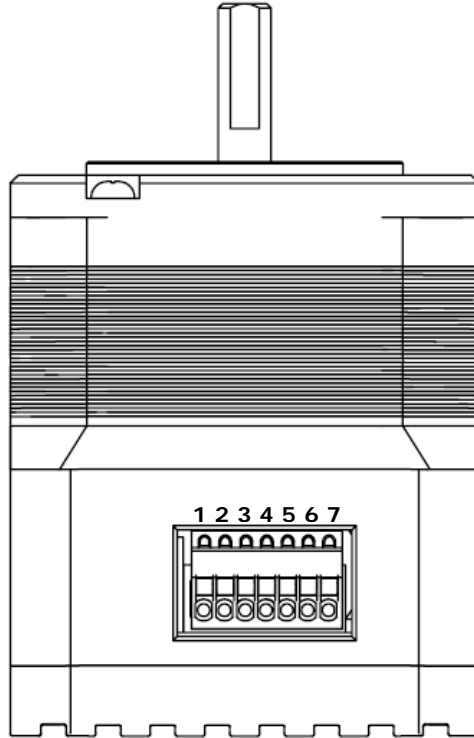

Figure 5: View of Silverpak 23D Plus connector

Color	Pin	Function	Description
Red	1	POWER +VE	Motor Supply Voltage. +12 to 75 VDC
Green	2	Ground	Power Supply Ground
Black/White	3	Enable	Enable/Disable
Orange	4	Direction	Direction input. Default connection will rotate CCW. If this input is low, rotation will be CW. You can swap this by using the GUI interface and clicking the button "Forward Rotation/Reverse Rotation". (Command DR)
Yellow	5	Step	Step pulse input. The step clock input will receive a clock pulse input (TTL squarewave, 0 to 5VDC), where one pulse will move the motor one step.
Blue	6	Internal 5V out	5VDC output. Used to power Pin 7, the opto reference, if users do not want to use an external 5VDC supply. By using this to power the optos, the device is no longer optically isolated.
Red or Red/white	7	Opto reference*	5 VDC is required to power the optocoupler reference. This device is for sinking operation with a max input current of 15mAmps.

Table 2: Pin Assignments

*NOTE: If using more than 5VDC to supply the opto reference, pin 7, please see Section 6 for correct resistor values based on the voltage.

The colors listed above are recommended color codes which match the cables that come with the Silverpak 23D Plus. If you request for lead wires to come directly out of the board, these are the colors it will follow, where Pin 7 will be a red & white striped wire.

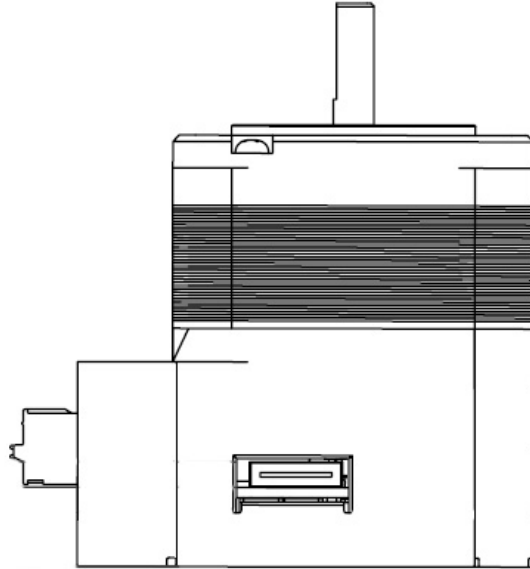

Figure 6: Communication Port View

The above image shows the communication port on the Silverpak 23D Plus. The 18-position cable plugs into this port. (This cable is sold separately)

The opposite end of the communication cable is a 3-pin IDC (Insulation Displacement Connector).

This connects to either the RS232 or USB converter card.

Color	Pin #	Function
White	1	RS485 A (-VE)
Blue	2	Ground
Yellow	3	RS485 B (+VE)

Table 3: Communication Pinouts

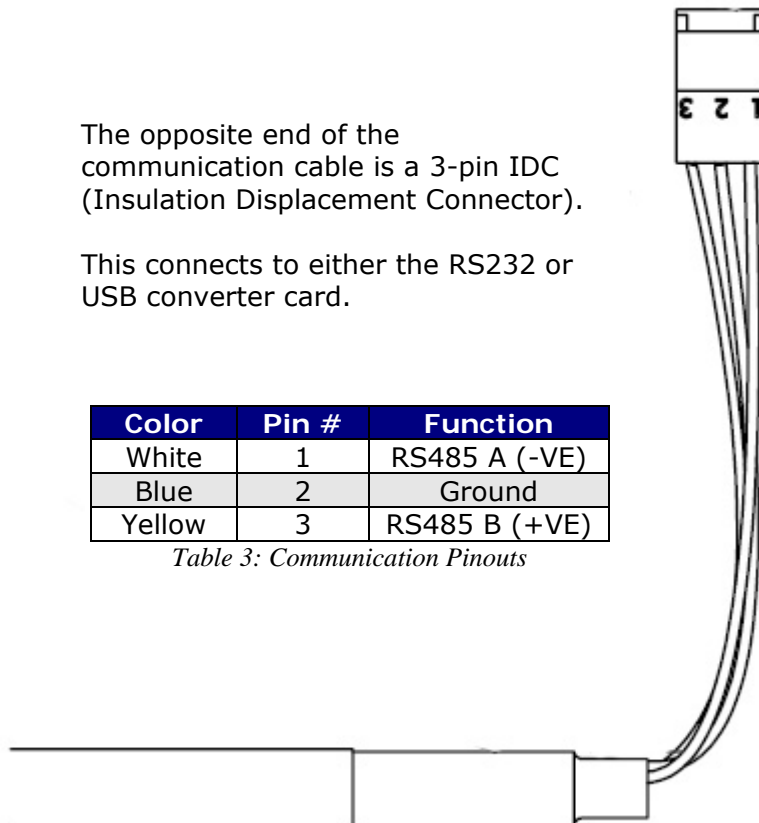

Figure 7: Communication Cable

6 CONNECTION SPECIFICATIONS

In order to properly connect your new Silverpak 23D Plus unit, first determine which Designer's Kit you've purchased.

If you purchased a **USB485 Designer's Kit (Lin p/n USBKIT-02)**, then you should have received the following items:

- A black 18-position cable with 3-pin connector on other end (p/n 090-00216)
- USB to RS485 converter card
- A USB cable (6 feet long)



Figure 8: USB Kit

If you purchased a **RS232-485 Designer's Kit (Lin p/n RS232KIT-02)**, then you should have received the following items:

- An extra 3-pin cable
- An RS232 to 485 converter card
- A black 18-position header cable with 3-pin connector on other end (p/n 090-00216)

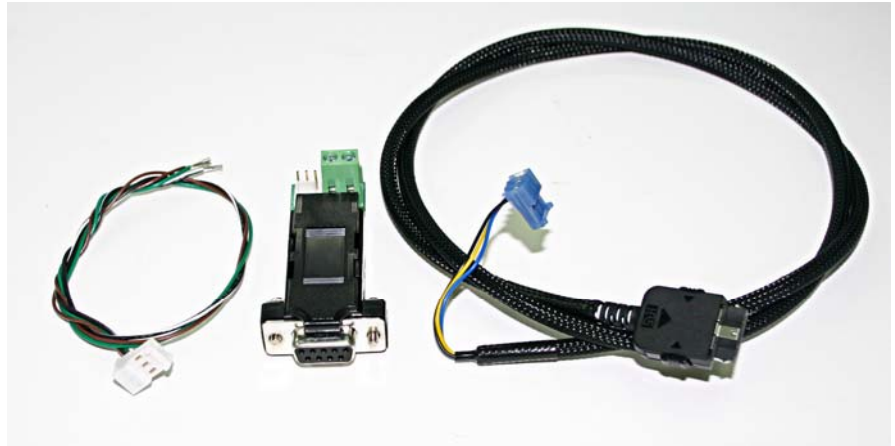

Figure 9: RS232 Kit

Note that the 18-position cable (090-00216) can be purchased separately.

Below are several options for connecting the Silverpak 23D Plus unit to your controller device.

WARNING! DO NOT DISCONNECT POWER FROM THE SILVERPAK 23D PLUS UNIT WHILE POWER IS STILL BEING SUPPLIED. THIS MAY CAUSE DAMAGE TO THE INTERNAL DRIVER BOARD.

WARNING! If you do not have a +5 VDC Power Source, use a Resistor in series to limit the current of the opto isolators. See page 14 for Resistor values. **If the current exceeds 15 mA, the opto couplers cease to function.**

1. Download driver files for the USB485 converter card

Go to www.linengineering.com and navigate to the USB485 converter card page by going to: Accessories → USB to RS485 Converter card. Then click on “Download”, or simply scroll to the bottom of the page.

Save the zip file called “USB485 Driver Files” and extract all files to your PC.

2. Connect the USB485 converter card to the Silverpak unit.

If using Lin Engineering’s USB485 converter card, simply take the 18-position cable and plug one end to the converter card, and plug the other end to the Silverpak 23D.

3. Connect USB cable to the PC.

Then plug one end of the USB cable into the converter card and the other end into your PC. When the converter card connects to your PC, it will find the new hardware and automatically ask you to download files. **It will download two files.**

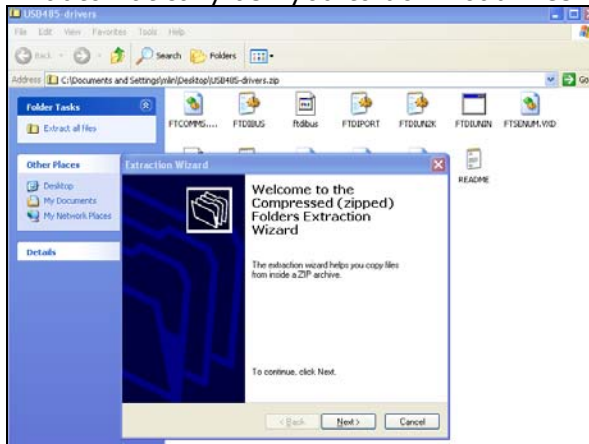

Figure 10: Extracting files

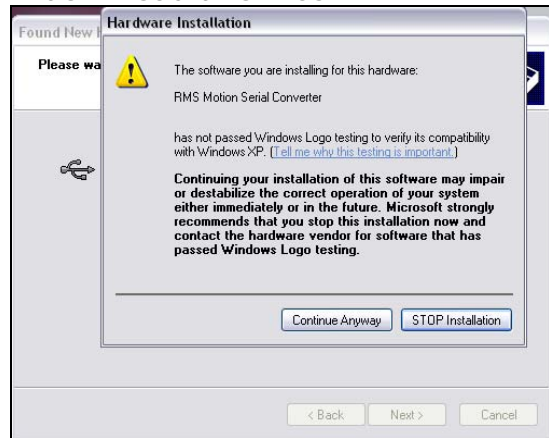

Figure 11: Downloading driver files

Connecting the Silverpak 23D Plus to your PC via USB

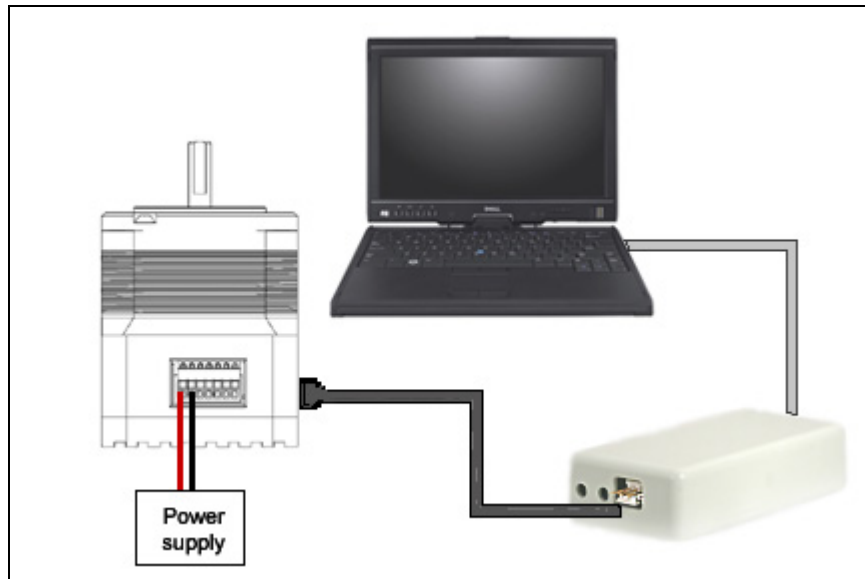

Figure 12: Connection of Silverpak to USB485 card, PC & Power Supply

Note the COM Port number that was assigned to the converter card device by right-clicking on "My Computer" and going to:

Hardware Tab → Device Manager → Ports (COM & LPT) → RMS Motion US485

Connecting the Silverpak 23D Plus to your PC via RS232

Follow the connection schematic shown below if using the RS485-RS232 Converter card.

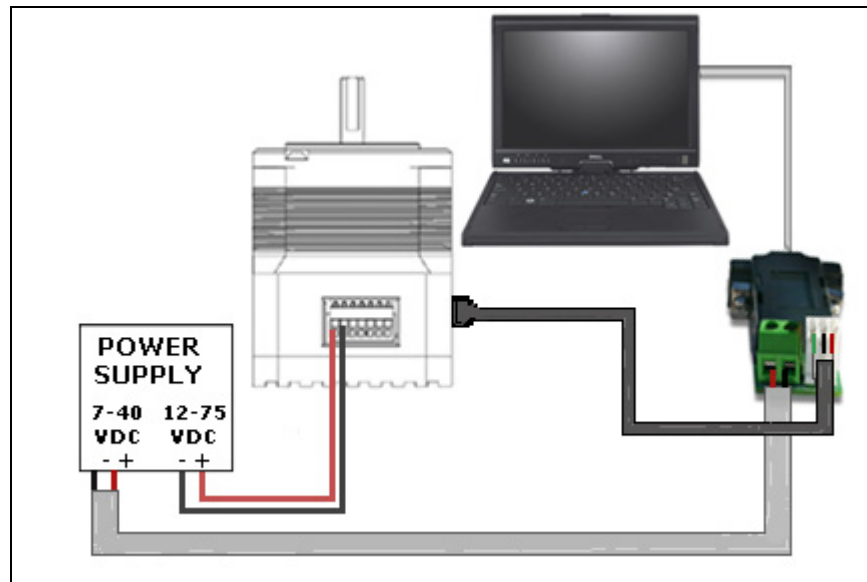





Figure 13: Connection of Silverpak to RS232 card, PC & Power Supply

Resistor Values for the Opto Supply

The optocouplers must be powered by an external power supply to maintain isolation. The Opto Supply for the optocouplers can be between +5 to 24 VDC with respect to the signal input. It is recommended to use a +5 VDC Opto Supply in order to limit the current going into the optocouplers to 10 mA. However, if the supply is greater than +5 VDC then a resistor must be connected in series with each signal line to maintain 10 mA of current running through the optocouplers (step, direction, and disable lines). **Do NOT provide more than 15 mA or damage may occur to the driver.**

The following page contains images of resistors and how to connect.

Step, Direction, and Disable lines have a 470 ohm internal resistor

Voltage:	5V	10V	15V	24V
Ohms needed:	0	500	1000	2000
Wattage rating:	0	¼ watt	¼ watt	¼ watt
Resistor image:				
		<i>Figure 14</i>	<i>Figure 15</i>	<i>Figure 16</i>
Color		Green Black Red Gold or Silver	Maroon Black Red Gold or Silver	Red Black Red Gold or Silver

Connect one resistor on the opto reference line, Pin 7. See image below:

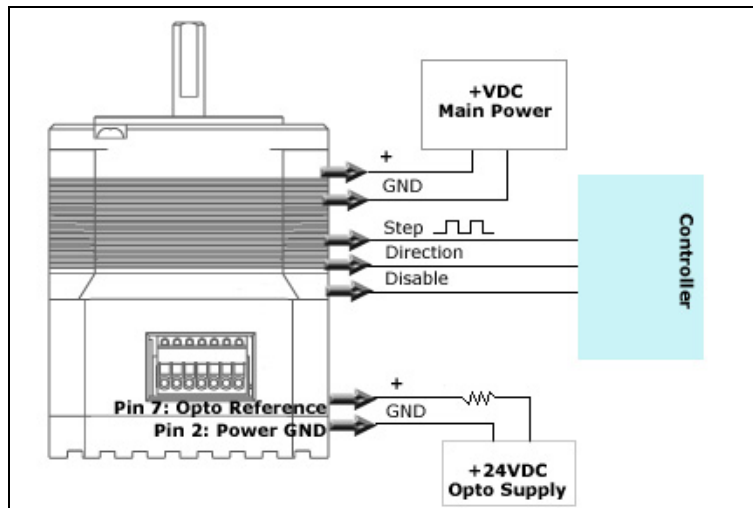

Figure 17: Connection with external resistor

If the desired voltage level is not listed above, below is how to calculate the resistor and wattage:

$$\frac{\text{Voltage} - 1.25V}{470\Omega + R} = 0.010\text{Amps}$$

or

$$R = \left(\frac{\text{Voltage} - 1.25V}{0.010\text{Amps}} \right) - 470\Omega$$

Equation 1: Resistance Equations

$$\text{Power} = \text{Resistor} \times \text{Amps}^2$$

or

$$\text{Wattage} = \text{Resistor} \times 0.0001\text{Amps}$$

Equation 2: Wattage equations

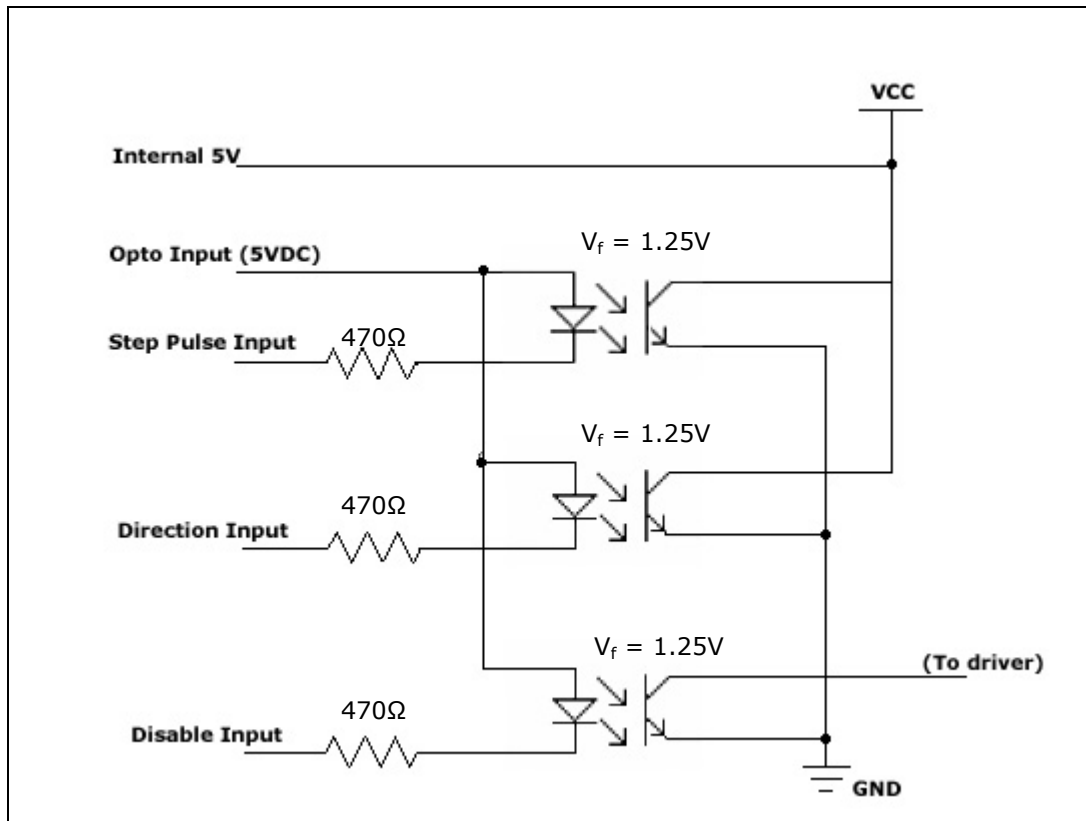

Figure 18: Internal Schematic

For easier connection, simply connect pin 6 to pin 7. This will take the Silverpak's internal 5VDC and supply the opto reference, and you therefore wouldn't need a separate supply.

7 Configuring The Settings

Connect to Lin Driver GUI for setting Parameters

Download the LinDriver.zip file from the Silverpak 23D webpage.

Connect to your PC, and turn on the Power Supply.

Figure 19: GUI

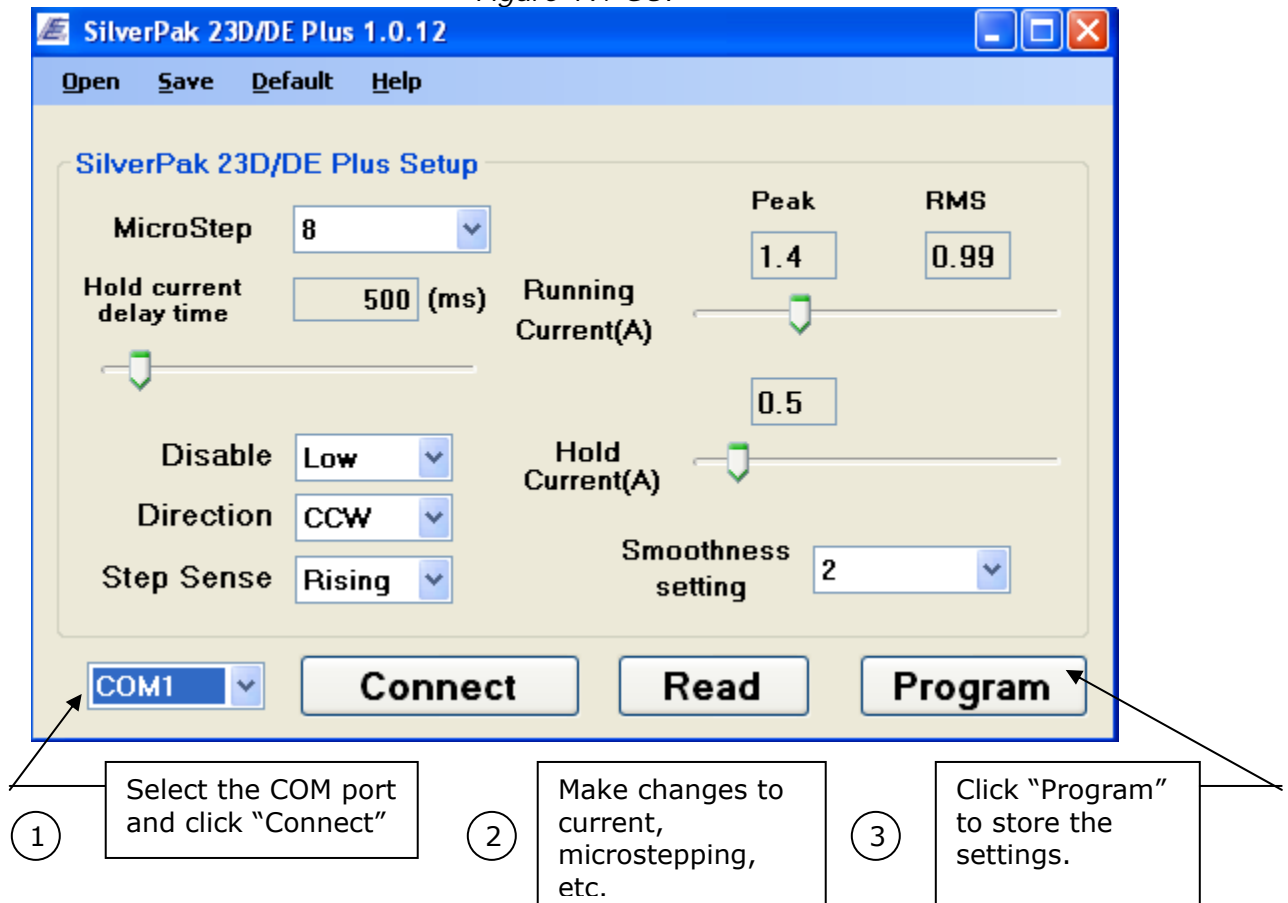

Setting	Values	Description
MicroStep 	Full step, 2x, 4x, 5x, 8x, 10x, 16x, 25x, 32x, 50x, 64x, 125x, 128x, 250x, or 256x.	MicroStep: Changes the step resolution such that the motor will step in smaller increments. This helps with smooth and quiet operation.
Hold current delay time 	0 to 6350 msec, in 50 msec increments 1000 msec = 1 sec	Hold current delay time: This setting is a time delay in milliseconds. After the last step pulse is sent to the motor, there will be a delay time for when the motor switches from run to hold current. This can be beneficial if moving a large load that needs high current during 1 or 2 seconds after a move is completed, but beyond this, you may want to hold the unit using less power.

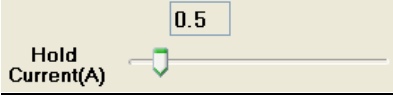
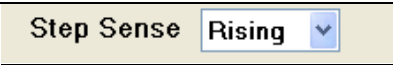
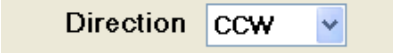
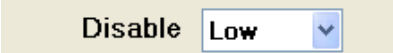
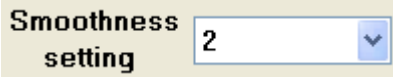
Setting	Values	Description
	0.5 Amps to 5.0 Amps, in 0.05 increments	Running Current: This changes the amount of current (Amps Peak) going into the motor. Do not exceed 1.4 times the motor's current. Every motor is labeled with a current rating. Going beyond 1.4 times this value can burn the motor. Increasing this value provides more torque. The Peak and corresponding RMS or Amps/Phase value is displayed above the scroll bar.
	0.0 Amps to 5.0 Amps, in 0.05 increments	Hold Current: This changes the amount of holding current used when the motor is not in motion. Do not exceed the motor's current rating. Increasing this value provides the ability to hold a heavy or large object in place.
	Detects step pulses on rising or falling edge	Step rising detect: Step pulses can be read using the pulse's rising (or positive) edge, or the falling (negative) edge. If you notice irregular stepping patterns, try changing this value.
	Motor will initially rotate CCW.	Direction: Upon power on, the motor will rotate counter-clockwise. If you desire that the initial direction of rotation be changed, choose "CW" for the motor to initially run clockwise.
	Disables the motor with a high (5V) or low signal (0V).	Disable: The disable pin is used to stop the motor. By default, it searches for a low signal in order to stop motion. By changing it to "high", the disable pin will search for a 5V signal to stop motion.
	0, 1, 2, 3	Smoothness setting: Changes the current waveform for smoother motion. Run motor at your desired operating speed while connected to a PC. Change smoothness setting to various values and audibly listen for quieter operation.
	Default settings	Default: When selecting the corresponding motor winding, all parameters will change to the default values and current is updated to the peak current of the motor winding. Upon viewing the changed settings, you must click "Program" in order to save these settings to the unit.

WARNING! Step motors can handle 1.4 times more than the motor's rated current. Going beyond this value could burn the motor and electronics. For more information on rated current (or RMS current) versus peak current, see the Appendix section.

8 **BASIC OPERATION**

List of components needed to rotate the motor:

- +12 to 75 VDC Power Supply
- Additional +5 VDC Volt Power Supply
- Signal Generator

Ensure that the Silverpak 23D is not connected to the Main Power Supply until the following procedures have been properly carried out.

1. Connect the step pulse generator

Connect Pin5, step pulse input, to the Positive Terminal of your pulse generator. Then connect the negative terminal to main ground power.

2. Connect the 5VDC supply

The Silverpak 23D requires a separate 5VDC supply for the optos that turn on the step, direction, and disable inputs.

Connect the positive terminal of your 5VDC supply to Pin 7, the opto input supply. The ground terminal of your supply should connect to the ground wire of the step pulse function generator.

Users have an option to use the Silverpak 23D's internal 5VDC supply for ease of use. Connect pin 6 to pin 7 with a wire. By doing so, the system is no longer optically isolated.

3. Connect the direction pin

The Silverpak 23D unit will rotate counterclockwise if the direction pin is not connected to anything. If the direction pin is pulled low, the direction of rotation will change to a clockwise direction.

Connect a switch from the direction pin to the ground connection on your opto supply.

4. Connect the disable pin

Simply connect a switch from the disable/enable pin to the ground connection on your opto supply. Connection to ground will disable the drive. No power will go to the motor.

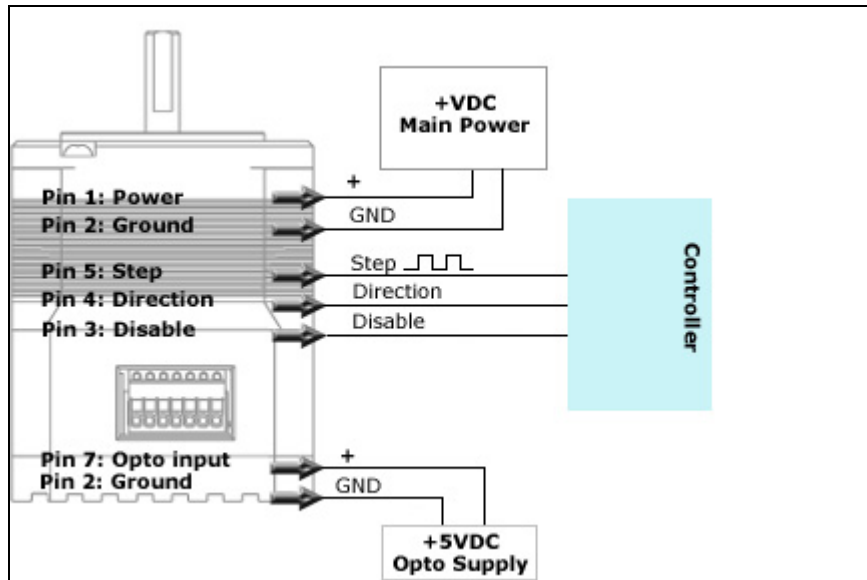

Figure 20: Connection Schematic – Connecting to a Controller

Connecting the Power

The Silverpak 23D requires a supply voltage of +12-75 VDC. First, connect the positive end of the power supply to Power (Pin 1), and then connect the negative of the power supply to the Ground (Pin 2) on the Silverpak 23D.

WARNING! Be careful not to reverse the polarity from the power supply to the driver. Reversing the connection will destroy your driver and void the warranty.

Connection Schematics

Using external 5VDC supply for optos:

If using an external 5VDC supply, connect the positive (+) terminal to the Silverpak's opto supply input, PIN 7.

If using a signal generator, connect the 5VDC supply ground terminal to the negative line of the generator.

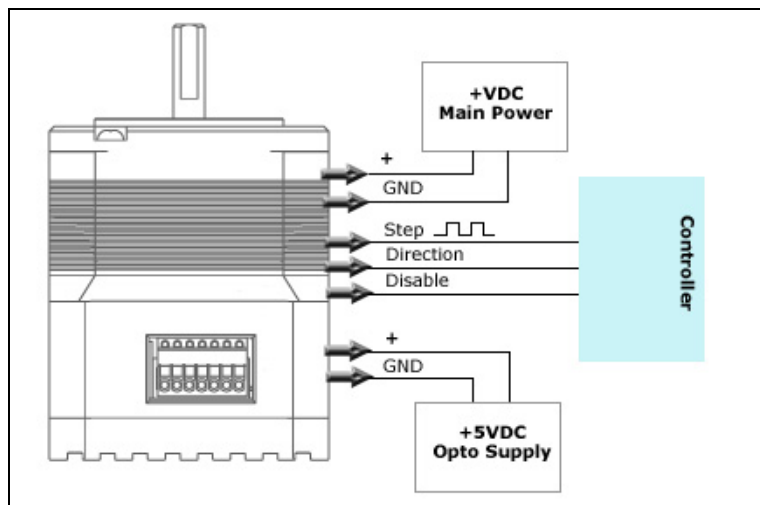

Figure 21: Schematic with 5VDC

Using Silverpak's Internal 5VDC supply for optos:

If using the internal 5VDC supply, simply connect PIN 6 to PIN 7.

Be sure to connect step pulse ground to the Silverpak's Ground, PIN 2.

Changing direction and disabling the drive is achieved by connecting these two inputs to PIN 2, ground.

This type of connection no longer optically isolates the inputs.

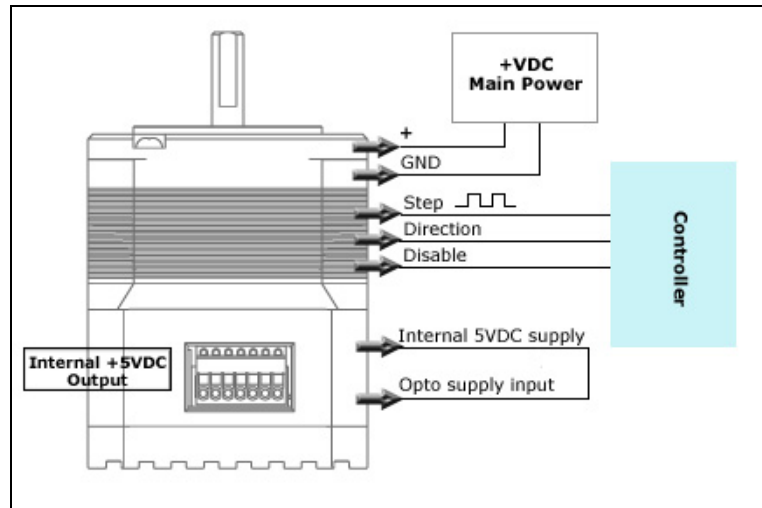

Figure 22: Schematic with internal 5VDC

Using more than 5VDC for external supply for the optos:

If using more than 5VDC, connect resistors in series with the opto supply input, PIN 7. Use the table in the previous section to determine what resistor to use.

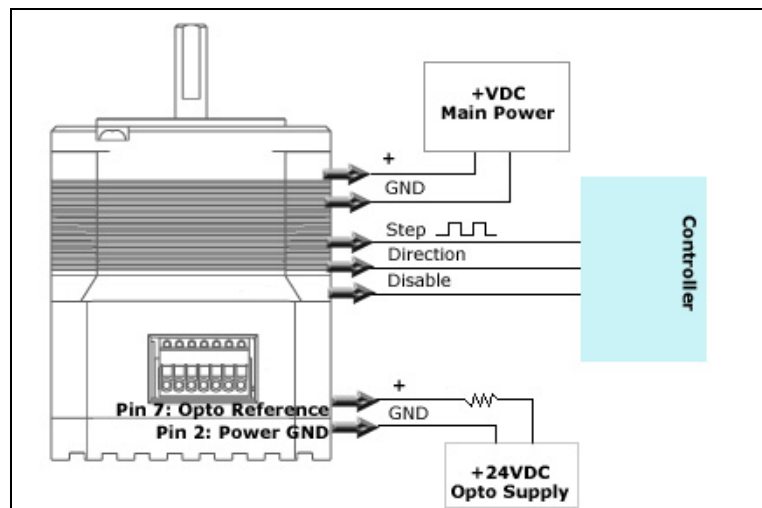

Figure 23: Schematic for more than 5VDC

9 TROUBLESHOOTING

The motor is not functioning correctly (does not move)

Check if power is being supplied to the unit. If the shaft of the motor is hard to turn, power is on. Next, check if the signal generator is supplying pulses correctly. Verify that the 5V is being supplied to the opto couples either via a separate power source or the internal 5V from Pin 6.

The motor is running erratically

Check that step pulses are a clean TTL squarewave signal. If one of the pulse edges are not clear, try switching the "Step Rising/Falling detect" option in the GUI interface. Check if increased microstepping helps minimize the jittering. If so, you are experiencing the motor's natural resonance that cannot be avoided, but can be minimized. Try also adding more load to the motor.

If the motor is still erratic and you seem to have a huge loss in torque, the driver chip may have malfunctioned.

Motor gets very hot

Keep in mind that the motor side can handle up to 90°C and the bottom of the unit where the driver board is located, can handle up to 75°C. This can be very hot when touching it by hand.

If the unit experiences thermal shutdown, where the unit begins to decrease in torque, you may need to lower the current in order to keep temperatures lower. The Silverpak unit has been tested in a 50°C ambient temperature, but if your system does not have good circulation, you might experience issues.

Try adding a fan to the unit, or mount the motor to larger metal heatsink.

GUI error codes

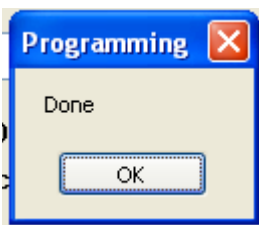

Figure 24

After clicking "Program", it should give you the "Done" response if it saved parameters successfully. After you click "Read", it shows this message as well.

Once you click "OK" on the dialog box, the values will be updated with what was programmed in the device.



Figure 25

A "failed" dialog box happens if you are connected to the wrong Port and therefore cannot read or program. Or if there is no power.

10 APPENDIX

Recommended Cable Configurations: DC Supply to Driver

Cable length, wire gauge and power conditioning devices play a major role in the performance of your Lin Engineering Driver and Motor.

NOTE: The length of the DC power supply cable to the Driver should not exceed 50 feet.

The example below demonstrates the recommended cable configuration for DC power supply cabling less than 50 feet long.

Correct AWG wire size is determined by the current requirement plus cable length. Please see the Driver Supply Cable AWG Table in this Appendix.

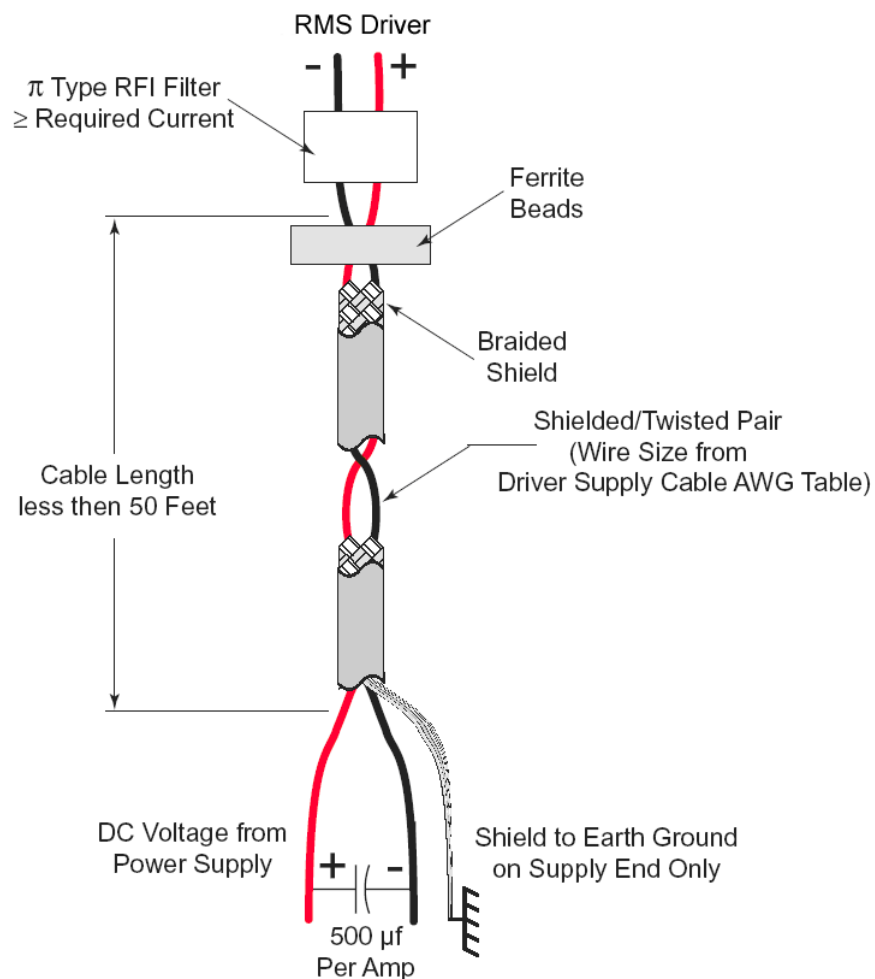

Figure 26

NOTE: These recommendations will provide optimal protection against EMI and RFI. The actual cable type, wire gauge, shield type and filtering devices used are dependent on the customer's application and system.

Driver Supply Cable AWG Table					
1 Amp (Peak)					
Length (Feet)	10	25	50*	75*	100*
Minimum AWG	20	20	18	18	16
2 Amp (Peak)					
Length (Feet)	10	25	50*	75*	100*
Minimum AWG	20	18	16	14	14
3 Amp (Peak)					
Length (Feet)	10	25	50*	75*	100*
Minimum AWG	18	16	14	12	12
* Use the alternative methods illustrated in Examples B and C when the cable length is ≥ 50 feet. Also, use the same current rating when the alternate AC power is used					

Table 4: Driver Supply Cable Wire Size

NOTE: Always use Shielded/Twisted Pairs for the Driver DC Supply Cable.

Step Rising/Falling Detect:

This feature allows for more compatibility with controllers and PLC's. The Silverpak 23D driver board receives step pulses from a pulse train, normally a TTL signal, sensing each pulse, one by one.

The step rising detection feature can choose where to sense each pulse: on the rising edge of the step or the falling edge (also known as the positive or negative edge).

Below depicts a step pulse train waveform where the rising edge is more of a curve. If the Silverpak 23D Plus is set to read this type of signal on the rising edge, inaccurate steps and unsmooth motion may occur.

It is best to switch the step sensing to the negative edge, or falling edge. Notice in this example, the falling edge is a clear signal and a definite difference between high to low.

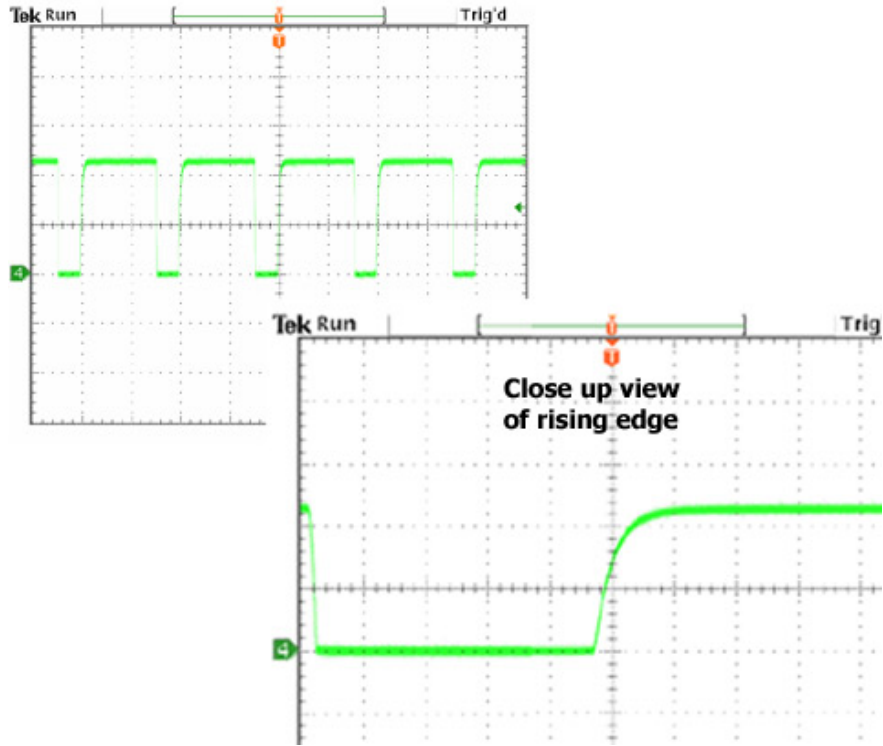

Figure 27: Example of a bad rising edge waveform

Below is an example of a good step pulse waveform where sensing the step on either edge would be fine:

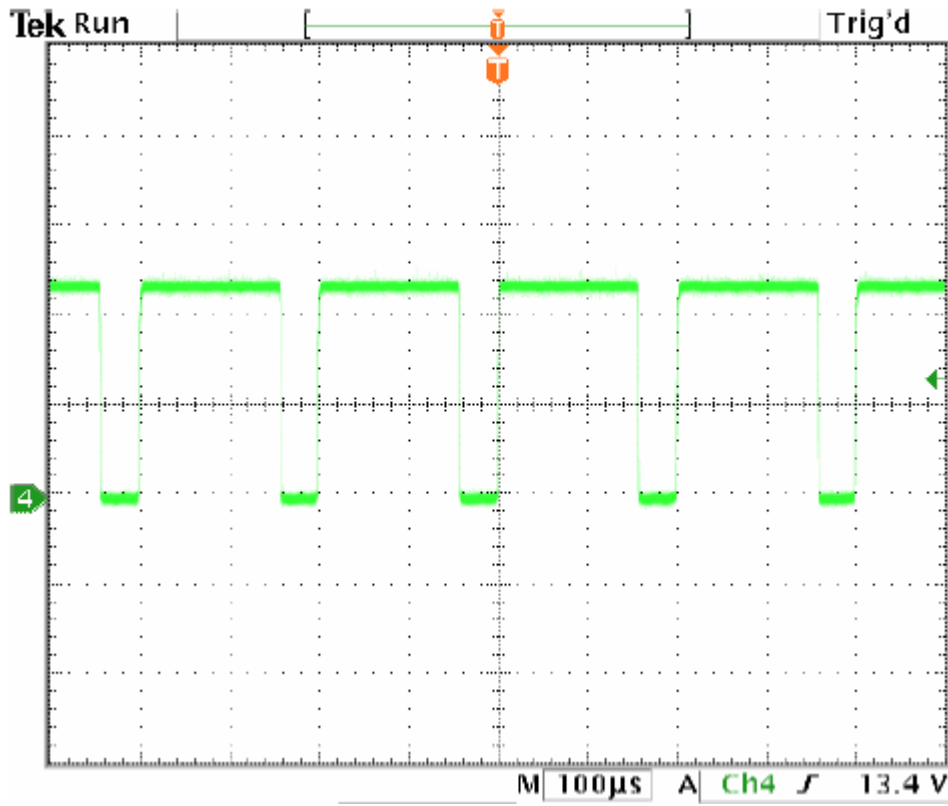

Figure 28: Example of a good waveform

Amps RMS vs. Amps Peak

Where does the 1.4 times come from? Current is continuously changing when a motor steps. If the motor is rated for 1.0 A/Ph, it may receive 0 Amps, 1 Amp, 1.4 Amps, or anything in between if you are microstepping. For ease of explanation, we will look at the current waveform when we half step, or set the driver/controller to 2x microstepping.

If we take a look at both the A and B phases, and plot on an X-Y chart of when each phase receives current, and how much it receives, it will look like the chart below. Beginning at position 1, Phase A receives negative current, and Phase B receives positive current. Let's assume it is at coordinate (-1, 1).

HALF-STEPPING Current Wave Form

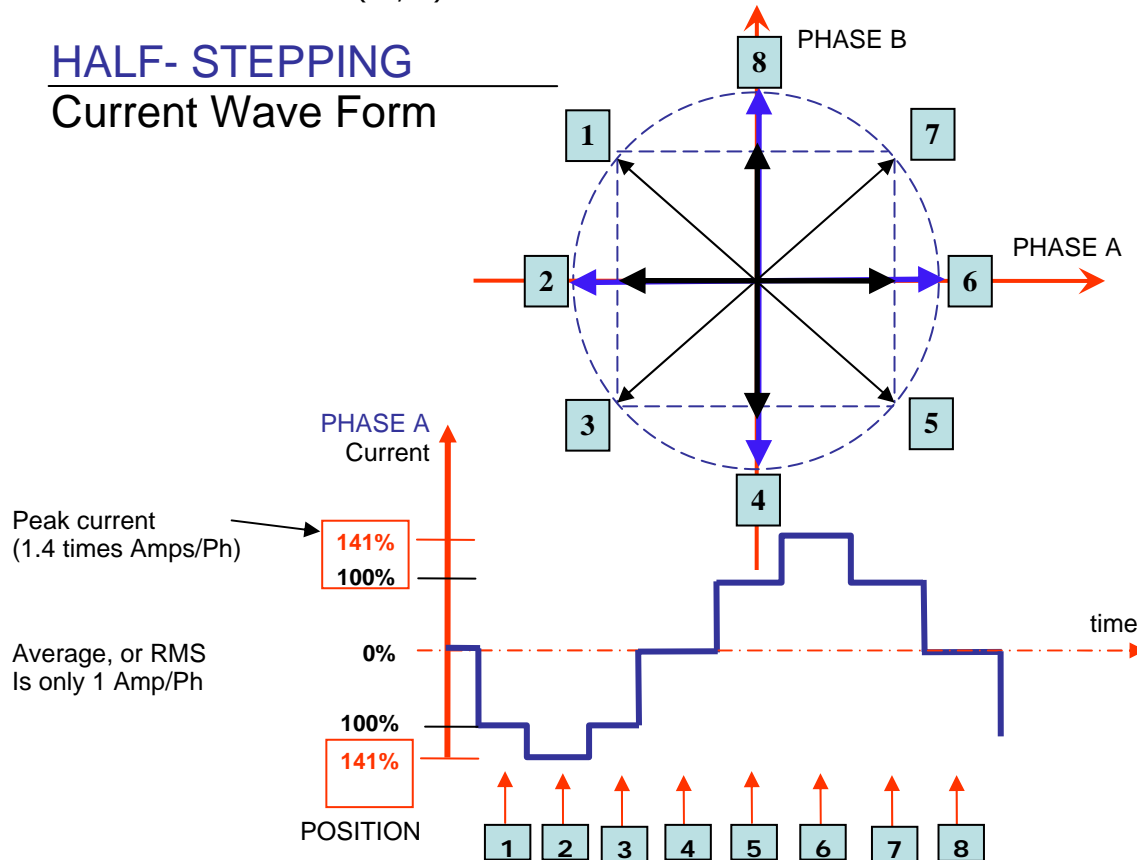

The position versus time graph above, plots only the A Phase, following the eight different steps the motor will make. Current is changing with each position. Recall that a negative in electronics simply means reverse direction of current flow.

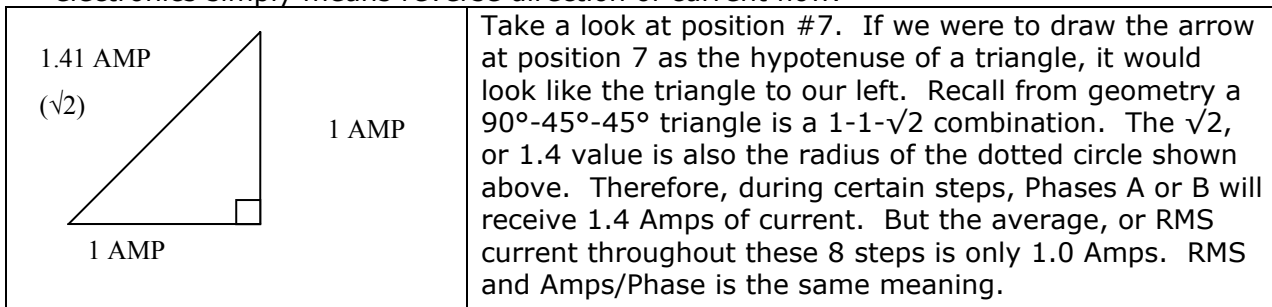

The 1.4A along this hypotenuse is also known as the 2-Phase On position, since both A and B Phases are "On" and receive current. It is also known as the *peak current*.

As we see the waveform that's plotted for the A Phase, the highest value on the curve is known as the peak value.

Motors have a rated current, or average RMS value since in operation, the current is continuously changing. The most logical way to describe a rating is to take an average, or RMS (root means squared) value. But drivers understand current in terms of peak current, therefore the conversion is: **Amps/Phase x 1.4 = Amps Peak**

For more Technical Support, contact:

Lin Engineering

408-919-0200

techsupport@linengineering.com

www.linengineering.com