

INSTRUCTIONS FOR OPERATION AND CARE OF **FORMA-SPLINT** THERMAL BATH



SP-1501

- SP-1501
- SP-1501B

- SP-1501-SLD
- SP-1501B-SLD



SP-1502

- SP-1502
- SP-1502B



Whitehall
Manufacturing[™]

P.O. Box 3527 • City of Industry, CA, 91744-0527, U.S.A.

800-782-7706 • 626-968-6681 • www.whitehallmfg.com

Member of  MORRIS GROUP
INTERNATIONAL

WARNING



**PLEASE READ THIS ENTIRE
BOOKLET BEFORE OPERATING
YOUR NEW SPLINT PAN**

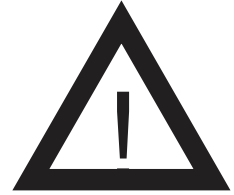

**Failure to follow these instructions could result in damage to
your new heating appliance and/or injury**

European Union CE Mark

The presence of the CE Mark on Whitehall equipment means that it has been designed, tested and certified as complying with all applicable European Union regulations and recommendations.

Waste Electrical and Electronic Equipment (WEEE)

This symbol on the product or on its packaging indicates that this product must not be disposed of with regular waste. Instead, it is the user's responsibility to dispose of waste equipment according to the local laws. Separate collection and recycling of the waste equipment at the time of disposal will help conserve natural resources and ensure it is recycled in a manner that protects human health and the environment. For information about where the user can drop off the waste equipment for recycling, please contact your local waste collection authority. See pages 11 and 12 for instructions on how to disassemble the equipment for recycling purposes.

Electric Shock

The Electric Shock Symbol is used to indicate a hazard arising from dangerous voltage. Any mishandling could result in irreparable damage to the equipment and/or personal injury or death.

General Warning or Caution

The Exclamation Symbol appears in Warning and Caution statements. This symbol designates where personal injury or damage to the equipment is possible.

	<p style="text-align: center;">WARNING</p> <p>To avoid electric shock, connect the instrument to properly earth-grounded, GFCI protected, 3-prong receptacles only. Failure to observe this precaution can result in severe injury.</p>
---	---

- DO NOT operate the appliance without properly filling with water. Under no circumstance should the appliance be operated without water, as operating the appliance without water may result in damage to the heating element. Appliance must be unplugged while filling or emptying water.
- CONNECT the appliance into a properly polarized G.F.C.I. (Ground Fault Circuit Interrupter) electrical receptacle for protection against electrical shock. Have a qualified electrician verify the wall socket is properly polarized and grounded. Use only the power cordset provided with the unit. The Splint Pan appliance must be properly grounded.
- AVOID skin contact with HOT water at all times! Carefully place splinting material into the Splint Pan appliance to avoid splashing onto skin or coming into contact with HOT water. DO NOT reach into HOT water with bare hands to remove heated splint material. Use a grasping device, such as tongs, to remove splint material from HOT water.
- DO NOT use in the presence of flammable liquids or gases, as these may present a fire and/or explosion hazard.
- ALWAYS allow the appliance to cool down before draining water or moving unit.
- DO NOT use the lid handle to lift or transport appliance.
- NEVER leave appliance operating unattended for long periods of time. Water can evaporate and cause appliance to overheat which may result in damage to the heating element. Turn "OFF" when not in use.
- FOLLOW splint material manufacturer instructions for proper material heat up temperature and duration.

WHITEHALL MANUFACTURING, P.O. BOX 3527 • City of Industry, CA 91744-0527, USA

WHITEHALL MANUFACTURING • P.O. BOX 3527 • City of Industry, CA 91744-0527 U.S.A

Phone (800) 782-7706 • (626) 968-6681 • Fax (626) 855-4862 • Web: www.whitehallmfg.com



TABLE OF CONTENTS

Why Forma-Splints?	2
Model Descriptions for SP-1501.....	2
Model Descriptions for SP-1502.....	3
Instructions for Use.....	4
Removal of Water	4
Cleaning	4
Sanitizing the Bath.....	4
To Change Temperature Settings	5
Changing the Operating Thermostat	5
Changing the Fuse	5
Repair of Unit.....	5
Whitehall Splint Pans Table	6
Model Diagram for SP-1501	7
Electrical Diagram for SP-1501	8
Model Diagram for SP-1502	9
Electrical Diagram for SP-1502	10
Electrical Parts Disassembly for SP-1501	11
Electrical Parts Disassembly for SP-1502	12

WHY FORMA-SPLINTS?

Forma-Splint Pans are made out of durable stainless steel to resist corrosion. The heating element has also been specially designed to insure even heating of the splinting material. Both models feature variable temperature settings and a convenient drain. Grounded plugs and high heat safety switches are standard.

Model SP-1501 has a spacious interior that accommodates splinting sheets up to 24" x 18" (61cm x 46cm).

Model SP-1502 has a compact design that makes it universally ideal for clinical use. The unit accommodates sheets up to 19" x 11" (48cm x 28cm).



Instructions for Operation and Care of Forma-Splint Thermal Bath

MODEL SP-1501

100-120 Volts, 50/60 Hz,
15 Amps

MODEL SP-1501B

200-240 Volts, 50/60 Hz,
8 Amps

Environmental conditions
recommended 41°F to 113°F
(5°C to 45°C) <90% RH

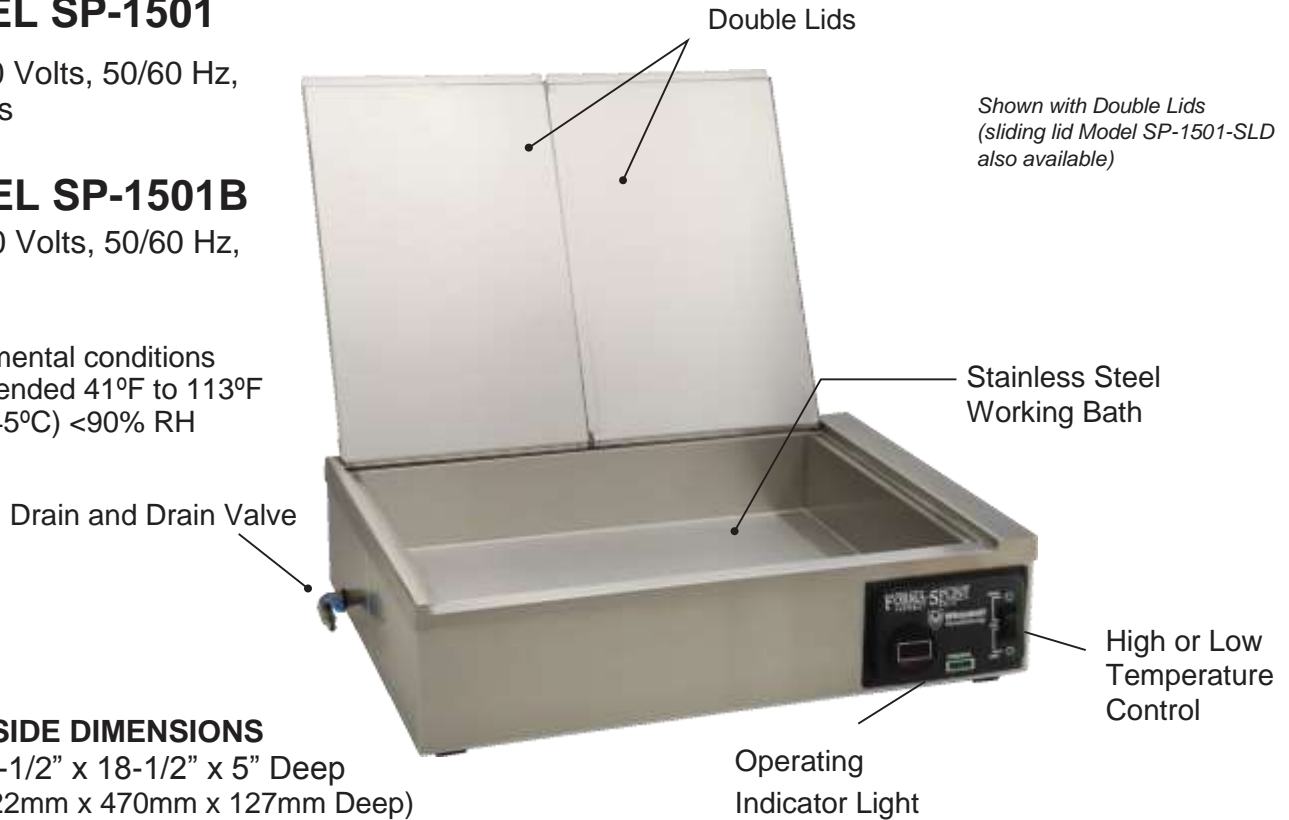

INSIDE DIMENSIONS

24-1/2" x 18-1/2" x 5" Deep
(622mm x 470mm x 127mm Deep)

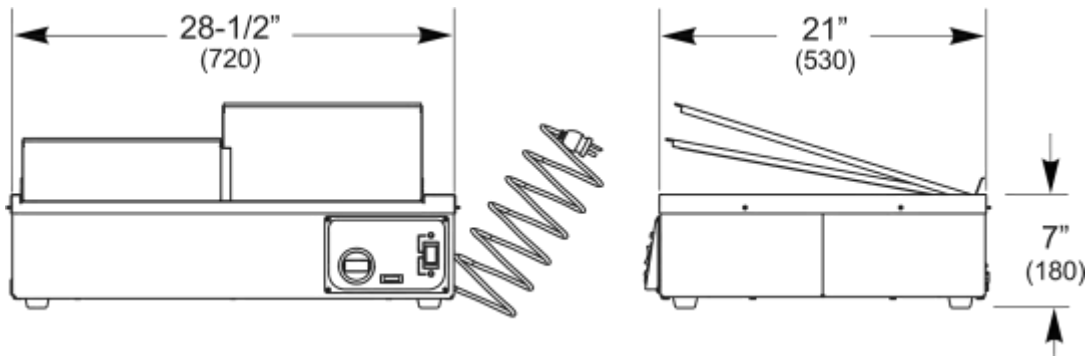

MODEL SP-1502

100-120 Volts, 50/60 Hz,
6 Amps

MODEL SP-1502B

200-240 Volts, 50/60 Hz,
4 Amps

Environmental conditions recommended 41°F
to 113°F (5°C to 45°C) <90% RH



INSIDE DIMENSIONS

19-1/2" x 11-7/8" x 4-1/2" Deep
(500mm x 300mm x 110mm Deep)

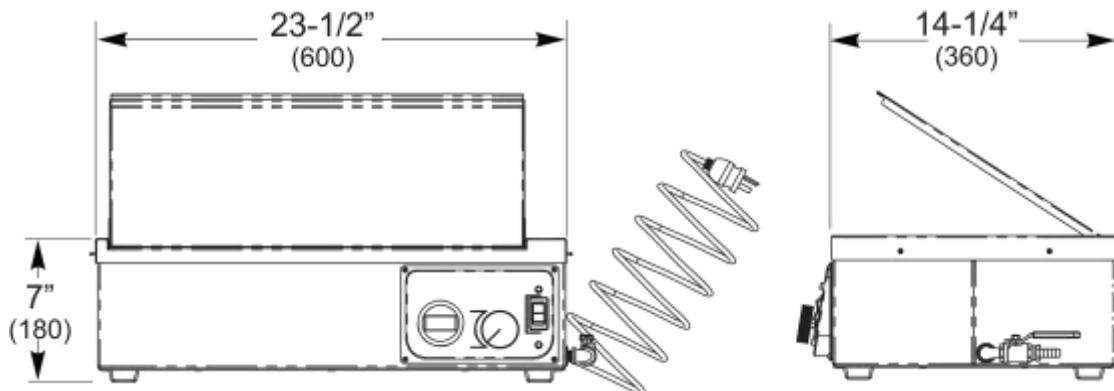

OPERATOR SKILLS AND TRAINING

Skills:

Operators using the whirlpool need a working knowledge of occupational therapy procedures.

Training

Operator trainees need to:

- be trained in occupational therapy protocols.
- read and understand this manual.

⚠ WARNING

Only trained personnel should operate the Splint Pan. Untrained operators can cause injury or be injured.



INSPECTING THE SPLINT PAN

This Whitehall product has been carefully packaged at the factory to minimize the possibility of damage during shipping.

- Inspect the packaging for external signs of damage.
- Inspect the contents for damage.

If there is visible damage to the instrument upon receipt, inform the shipping company and Whitehall immediately.

SET-UP INSTRUCTIONS

WARNING

Do not attempt to operate this equipment if there is evidence of shipping damage or you suspect the unit is damaged. Damaged equipment may present additional hazards to you. Contact Whitehall technical support for advice before attempting to plug in and operate damaged equipment.

1. Your new Splint Pan includes the following:

- (1) Heating Appliance
- (1) Power Cordset
- (1) Warranty Registration Card
- (1) Operation & Maintenance Manual

NOTE: If you are missing any of the above, contact **WHITEHALL MANUFACTURING** toll free telephone no. (800) 782-7706 or (626) 968-6681

2. Unpacking your Splint Pan

Remove all shipping & packaging material. Remove all items from inside of tank such as Power Cordset, Filler Hose, Warranty Registration Card, and Operation & Maintenance Manual.

3. Location of your Splint Pan

Place the Splint Pan at a convenient height & location such as on a table or scratch-resistant counter top.

IMPORTANT: Appliance must be placed on a level surface! Splint Pan must be positioned so to allow ease of disconnecting Power Cordset if necessary.

4. Preparing to Fill your Splint Pan

Make sure appliance is unplugged and all packaging has been removed from reservoir. Ensure that the inside of tank is thoroughly clean before filling with water.

DO NOT use any medium except water.

Check drain valve and make sure handle is in the "closed position" by turning clockwise to make certain no water in tank will drain out of appliance while being filled.

Inspection Checklist

- Is the Splint Pan free of excessive wear?
- Is a properly-grounded and voltage-matched receptacle available?
- Is the outlet equipped with a functioning GFI?
- Does the drain valve open and close properly?

5. Filling your Splint Pan

Appliance must be unplugged. Fill reservoir with water to at least 3" (76mm) deep.

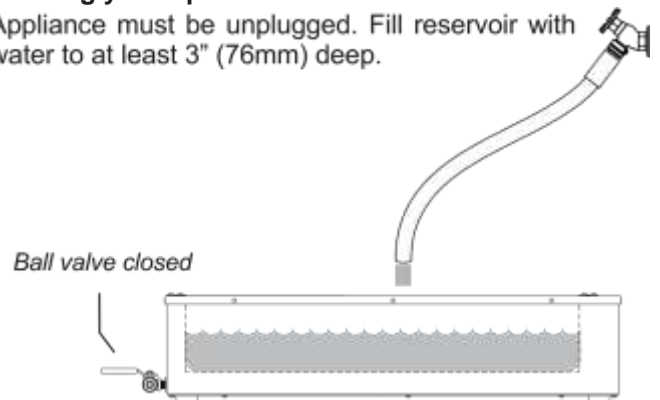

SET-UP INSTRUCTIONS

(continued)

6. Preparing to turn "ON" your Splint Pan

Close lid.



Lid can pinch fingers.

Locate the Power Switch at front of the appliance and make sure it is set to "OFF". Insert connector end of power cordset into power inlet at back of appliance.

Connect plug end of power cordset into a G.F.C.I. protected AC electrical receptacle.

7. Turning "ON" your Splint Pan

You are now ready to turn "ON" the appliance. Locate the Power Switch at the front of the unit and press to "ON" position.

8. Adjusting/Setting the Heat-Up Temperature

To change the set temperature on the model SP-1501, drain the water and unplug the unit. Carefully remove the four screws holding the nameplate and locate the two thermostat knurled knobs. The top knob is the thermostat for the high temperature limit setting and the bottom knob is the thermostat for the low temperature limit setting. Insert a small screwdriver into the slotted head of the thermostat knob turning clockwise to raise the



temperature limit and counterclockwise to lower the temperature limit. Please note that 1/8 of a turn is approximately equal to $\pm 5^{\circ}\text{F}$ (-15°C).

DO NOT turn the thermostat more than one full turn in either direction. Reinstall the nameplate and fill the unit with 3" (76mm) of water. During manufacturing the low temperature is preset at 160°F (71°C) and the high temperature at 175°F (79°C).

On the standard SP-1502 model, the temperature is varied by turning the thermostat knob clockwise for an increase and counterclockwise for a decrease in temperature. The temperature on low setting should approximate 140°F (60°C) and on high 190°F (88°C).

⚠ WARNING

Use the Splint Pan only as directed in this manual. Any other use can cause injury.

USING YOUR SPLINT PAN

Once the digital display indicates the desired temperature, the appliance will be ready for use. Allow $\pm 3^{\circ}\text{F}$ (-16°C) temperature variance.

Always refer to the correct temperature & duration specified by the splinting material manufacturer.

Be certain to heed all warnings as outlined in the WARNING section (inside front cover of this manual).

Keep lid closed while water is heating up.

Carefully insert splinting material into tank and avoid splashing HOT water. Avoid direct skin contact with HOT water at all times. While splint material is immersed in water, the lid should remain closed to help retain heat inside tank. Remove splint material from tank only after it has reached the manufacturer's specified duration. Use caution when removing splint material from tank. Apply splint material as specified by splint manufacturer's instructions.

Keep the lid closed when appliance is not in use. Maintain proper water level at all times. Immediately fill the appliance with water to 3" (76mm) deep. Avoid allowing water to reach a "very low water" level. A "very low water"

level would be any water level 3/4" (20 mm) or less water depth as measured from the tank bottom. Never operate appliance without water! These precautions will prevent the appliance from over-heating and prevent potential damage to the heating element.

EMPTYING YOUR SPLINT PAN

Before emptying (draining) your appliance, be sure that the power switch is set to "OFF". Allow the appliance to cool down before emptying. Lifting the lid will accelerate this cooling. The Splint Pan must be unplugged when emptying the reservoir. The appliance has been provided with a Drain Valve that has a 1/4" (6.35mm) barbed nipple to attach a hose.



CARE & CLEANING OF YOUR SPLINT PAN

Turn power switch "OFF" and unplug the unit from the electrical receptacle. If necessary, drain the appliance by following instructions as outlined in the "EMPTYING YOUR SPLINT PAN" section.

When cleaning, rinsing, and/or drying your appliance always rub in the direction of the stainless steel grain lines to minimize marring or scratching the surfaces.

Use mild soaps, gentle non-abrasive detergents, or mild mixtures of ammonia to routinely clean the surfaces of the appliance. Be sure to always rinse with clean, warm water and wipe dry. Use stainless steel cleaners such as *3M Stainless Steel Cleaner/Polish*, *Sheila Shine®*, *Twinkle® Stainless Steel Cleaner/Polish*, *Penny Brite*, *Cameo Stainless Steel Cleaner/Polish*, and *EZ Brite*, on stainless steel surfaces. Strictly follow brand name manufacturer's instructions on proper use of the stainless steel cleaner. **NOTE:** The use of brand names is intended only to indicate a type of cleaner.

DO NOT use bleach, chlorinated solvents, or other harsh chemicals to clean your appliance. DO NOT use steel wool to clean the stainless steel surfaces. For scaly, hard-water spots use a strong solution of vinegar & water and let it stand for approximately 5 minutes. Rinse with clean, warm water and wipe dry.

WHITEHALL SPLINT PANS

Whitehall Part #	Description	SP-1501	SP-1501B	SP-1502	SP-1502B
1	6903-112-199	Bottom Panel	x	x	
2	6903-212-199	Bottom Panel			x
3	6903-152-000	Drain Ball Valve (Stainless Steel) 1/4-18 NPT x 1/4	x	x	x
4	6903-160-000	Drain Barb (Stainless Steel) 1/4-18 NPT x 1/4	x	x	x

WHITEHALL MANUFACTURING • P.O. BOX 3527 • City of Industry, CA 91744-0527 U.S.A



Instructions for Operation and Care of Forma-Splint Thermal Bath

5	6903-166-000	Drain Elbow (Stainless Steel) 1/4-18 NPT x 1/4	x	x	x	x
6	6903-162-000	Drain Threaded Pipe (Stainless Steel) 1/4-18 x 3" NPT	x	x		
7	6903-262-000	Drain Threaded Pipe (Stainless Steel) 1/4-18 x 5" NPT			x	x
8	6903-256-000	Element, Heating 120V			x	x
9	6903-257-000	Element, Heating 220V			x	x
10	6903-156-000	Element, Heating 120V	x	x		
11	6903-157-000	Element, Heating 220V	x	x		
12	6903-168-199	Face Plate (Plastic) for Control Panel	x	x		
13	6903-268-199	Face Plate (Plastic) for Control Panel			x	x
14	0710-230-001	Fuse Holder Assembly, 5mm x 20mm		x		x
15	0710-232-000	Fuse Holder Assembly, 1/4 x 1-1/4 lg	x		x	
16	6900-136-000	Fuse, 15 Amp, 120V, Time Delay, 1/4 x 1-1/4 lg	x			
17	0710-226-000	Fuse, 8 Amp, 220V, Time Delay, 5mm x 20mm		x		
18	0710-233-000	Fuse, 6 Amp, 120V, Time Delay, 1/4 x 1-1/4 lg			x	
19	0710-203-000	Fuse, 4 Amp, 220V, Time Delay, 5mm x 20mm				x
20	6504-605-000	Cabinet foot	x	x	x	x
21	7000-415-000	J Nut, Self Retaining	x	x	x	x
22	6900-130-000	Knob for Thermostat			x	x
23	6900-135-000	Light, Rectangular (Green) 125VAC	x			
24	6903-137-000	Light, Rectangular (Green) 250VAC		x		
25	6505-540-000	Light, Round (Amber) 125VAC			x	
26	6505-541-000	Light, Round (Amber) 250VAC				x
27	6900-134-000	Light, Round (Green) 125VAC			x	
28	6900-134-001	Light, Round (Green) 125VAC	x			
29	6505-542-000	Light, Round (Green) 250VAC		x		x
30	6900-108-000	Power Switch			x	x
31	6900-109-000	Power Switch (3 Way)	x	x		

WHITEHALL MANUFACTURING • P.O. BOX 3527 • City of Industry, CA 91744-0527 U.S.A Phone (800) 782-7706 • (626)

Instructions for Operation and Care of Forma-Splint Thermal Bath



32	6505-056-000	Powercord Assembly 120V	x		x	
33	Call for part #	Powercord Assembly 220V		x		x
34	6903-138-001	Rim and Lid Assembly (Stainless Steel)	x	x		
35	6903-238-001	Rim and Lid Assembly (Stainless Steel)			x	x
36	6903-338-001	Rim, Stainless Steel (Lid not included) SP-1501-SLD	x	x		
37	6900-128-000	Rubber Grommet	x	x	x	x
38	6903-195-001	Sliding Lid Assembly, Stainless Steel SP-1501- SLD	x	x		
39	6903-142-000	Thermometer, Digital (Fahrenheit) 120V Only	x		x	
40	6903-143-000	Thermometer, Digital (Celsius) 220V Only		x		x
41	6903-150-000	Thermostat, Capillary (Operating)	x	x	x	x
42	6903-146-000	Thermostat, L-145	x	x		
43	6903-144-000	Thermostat, L-200 (High Limit)	x	x	x	x
44	6502-100-000	#8-32 x 3/8" Phil Pan Head Screw	x	x	x	x
45	0116-013-000	#10-32 x 3/4" SST Phil Round Head Screw	x	x	x	x
46	6900-144-000	1/4" Clear Plastic Drain Hose (Not Shown)	x	x	x	x

WHITEHALL MANUFACTURING • P.O. BOX 3527 • City of Industry, CA 91744-0527 U.S.A Phone (800) 782-7706 • (626)



Instructions for Operation and Care of Forma-Splint Thermal Bath

MODEL SP-1501
MODEL SP-1501B

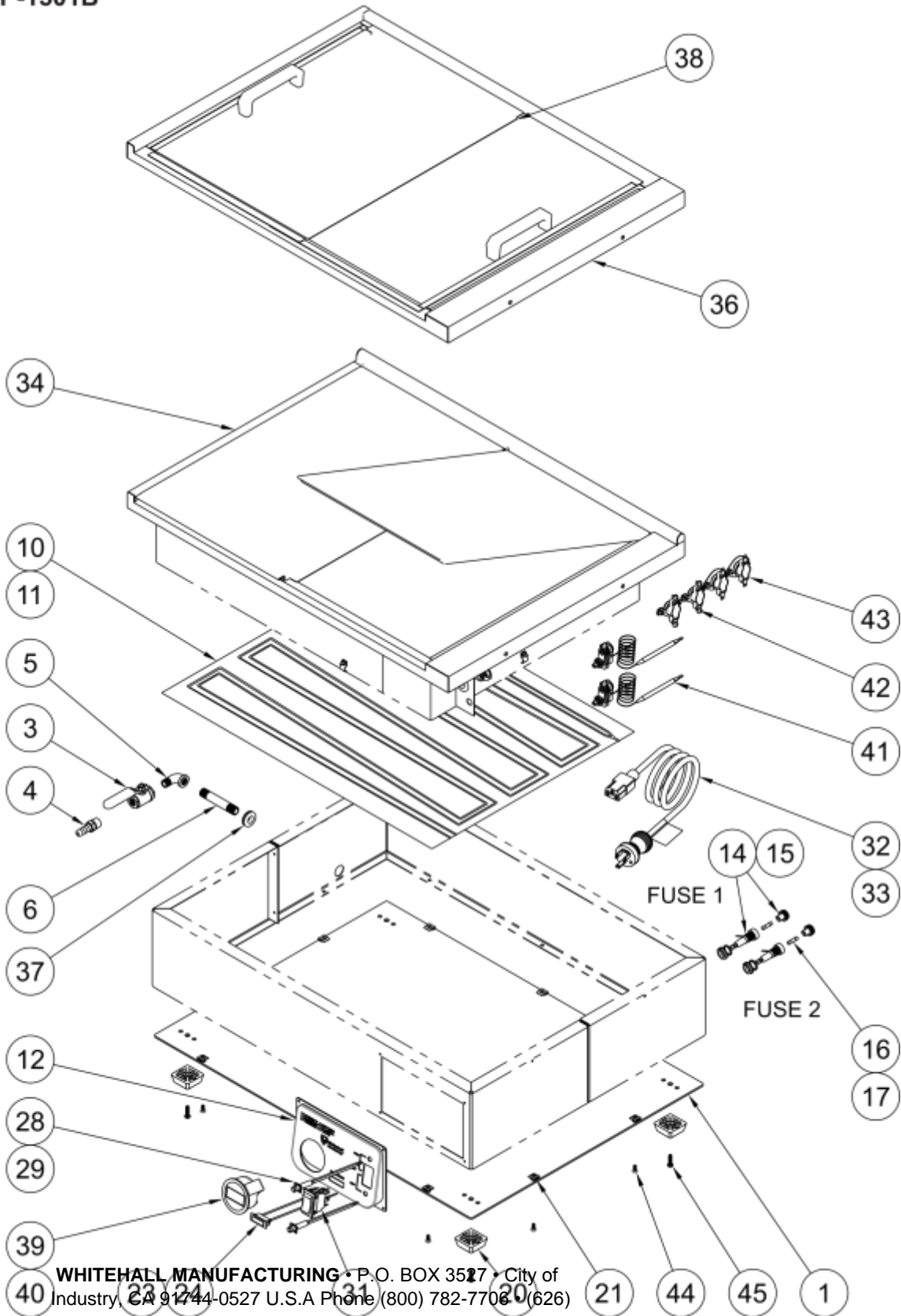

WHITEHALL MANUFACTURING • P.O. BOX 3527 • City of Industry, CA 91744-0527 U.S.A Phone (800) 782-7706 (626)

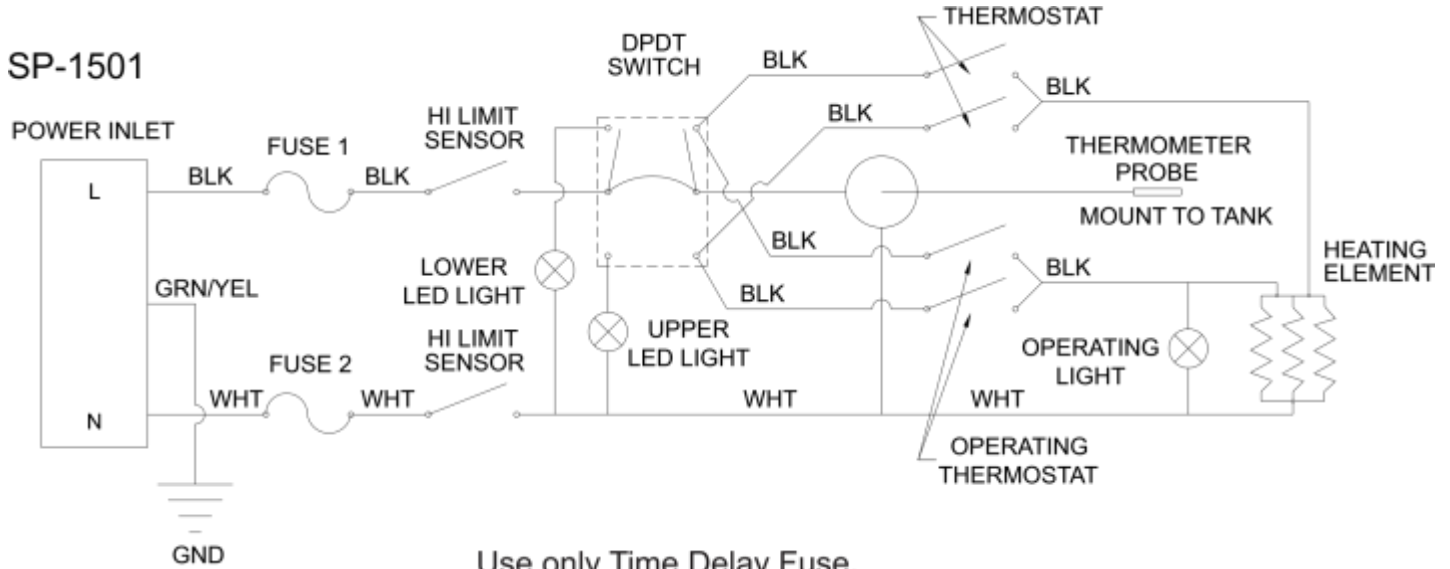

Use only Time Delay Fuse.
See Parts List, Page 6, Item 16

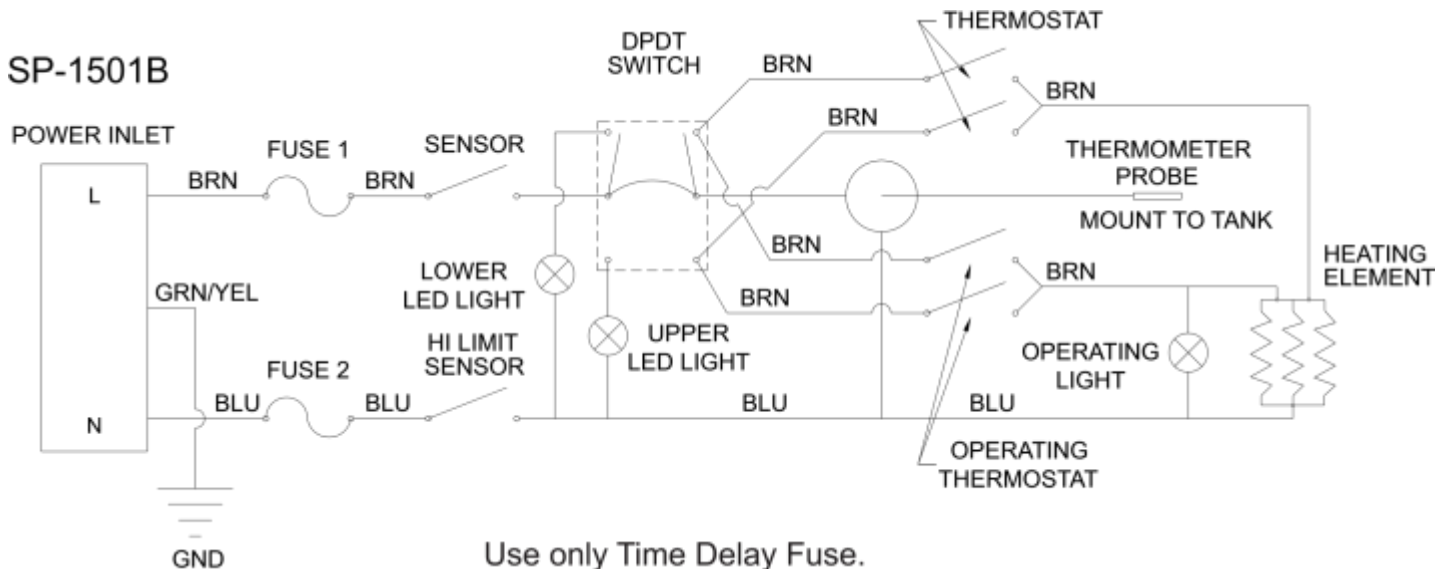

Use only Time Delay Fuse.

HI LIMIT

See Parts List, Page 6, Item 17



Protective Conductor Terminal

The protective conductor terminal symbol in the above figure identifies the location of the bonding terminal, which is bonded to conductive accessible parts of the enclosure for safety purposes.

Symbols on labels:

WHITEHALL MANUFACTURING • P.O. BOX 3527 • City of Industry, CA 91744-0527 U.S.A Phone (800) 782-7706 • (626)



SP-1502

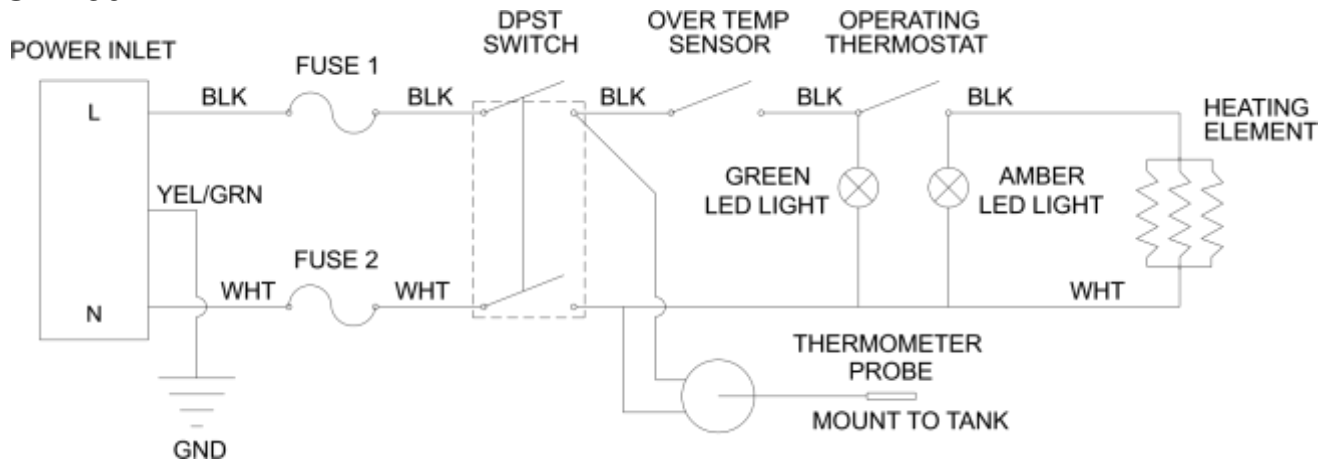

Use only Time Delay Fuse.
See Parts List, Page 6, Item 18

SP-1502B

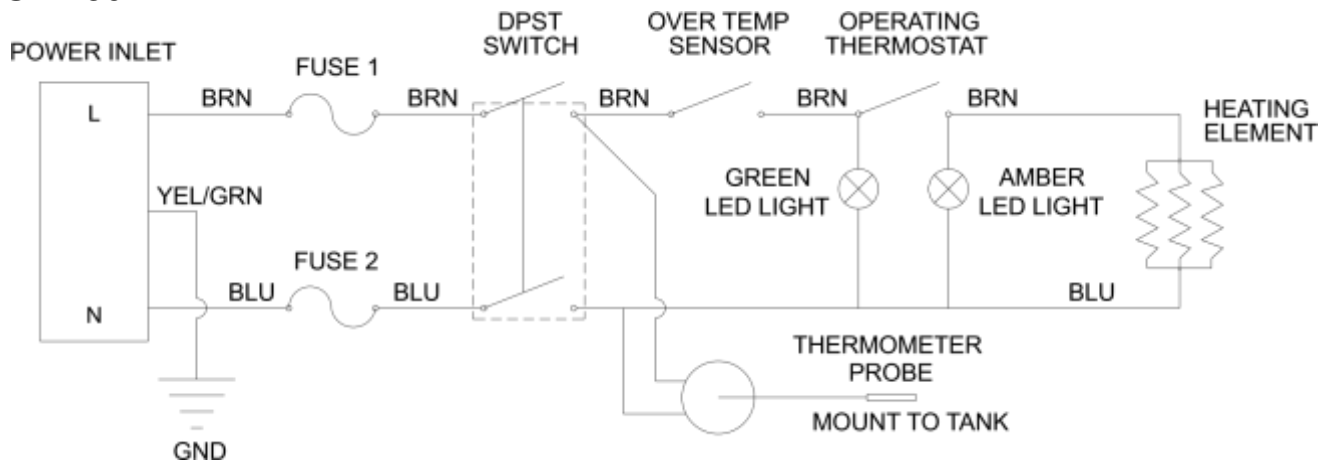

Use only Time Delay Fuse.
See Parts List, Page 6, Item 19



Protective Conductor Terminal

The protective conductor terminal symbol in the above figure identifies the location of the bonding terminal, which is bonded to conductive accessible parts of the enclosure for safety purposes.

Symbols on labels:



Alternating Voltage or Current

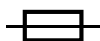

Fuse Location



**ELECTRICAL PARTS DISASSEMBLY
MODEL SP-1501
MODEL SP-1501B**

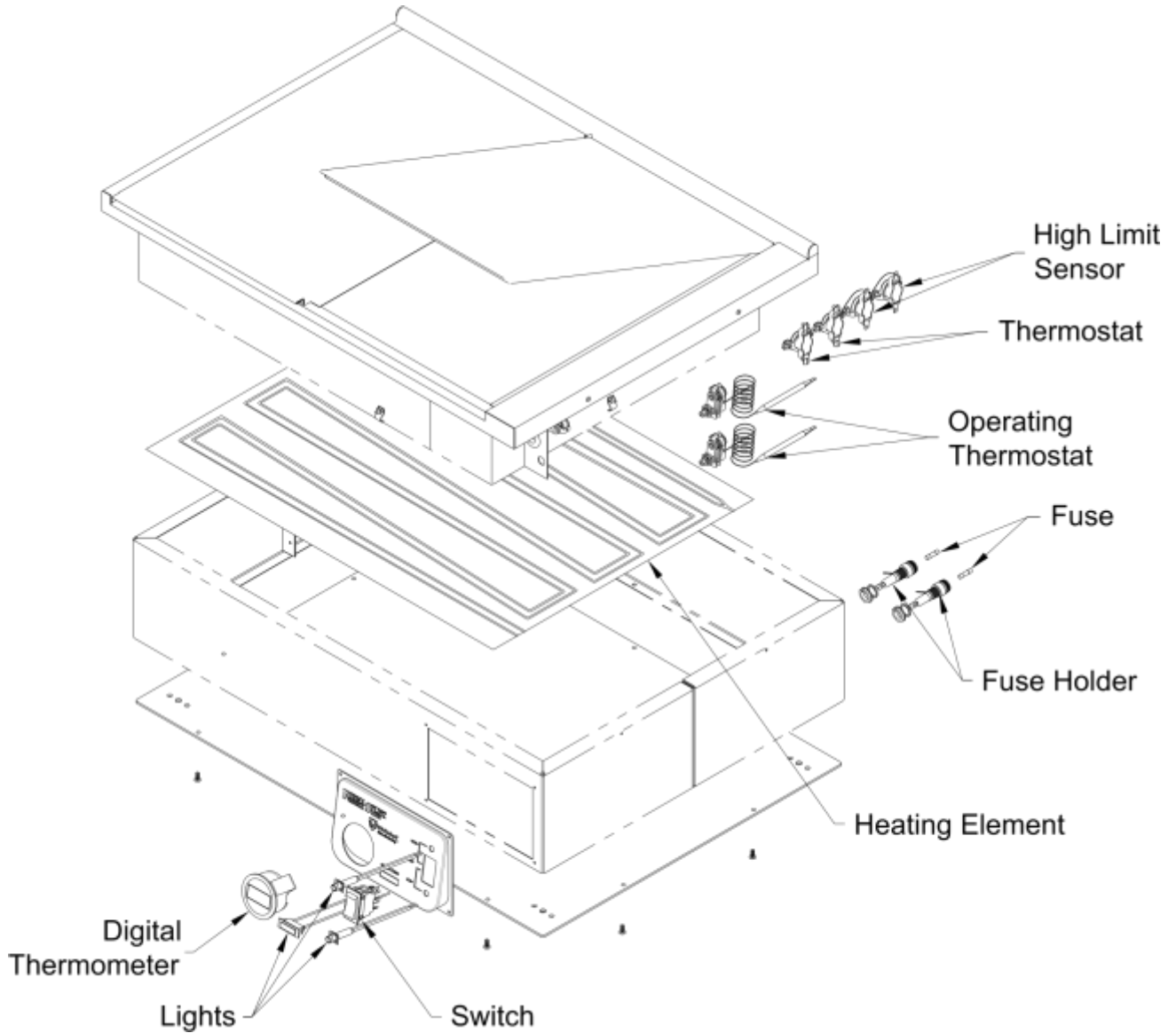

ELECTRICAL PARTS DISASSEMBLY



MODEL SP-1502 MODEL SP-1502B

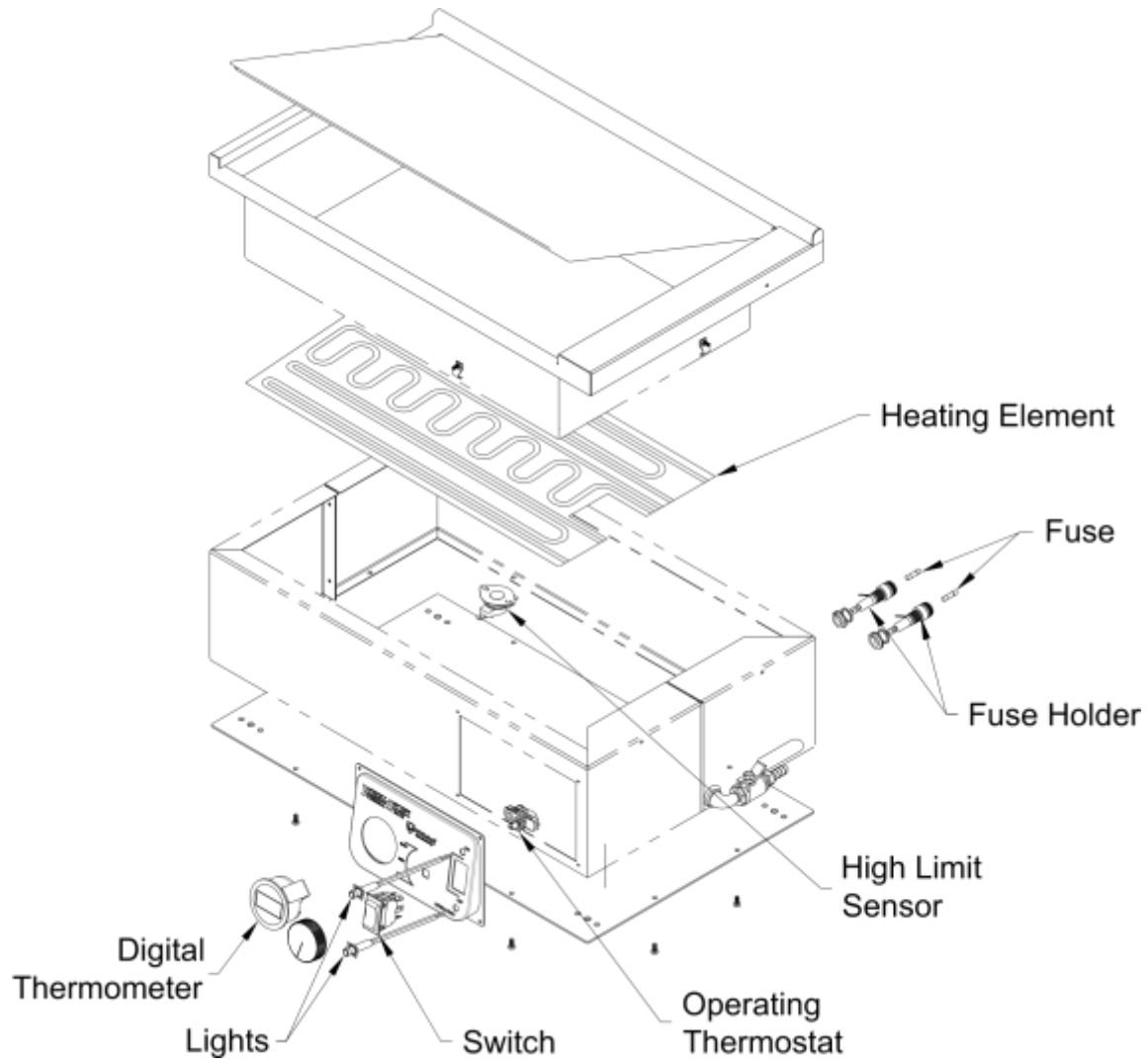





Mailing Address:

P.O. Box 3527 • City of Industry, CA 91744-0527 U.S.A

Physical Address:

15125 Proctor Avenue • City of Industry, CA 91746 U.S.A

Phone 800-782-7706 • 626-968-6681

Fax 626-855-4862

Web: www.whitehallmfg.com

E-mail: info@whitehallmfg.com

Any questions regarding servicing of products in Europe or the Middle East should be directed to:
Niva Medical Company • Olarinluoma 14 B, FIN-02200 Espoo, Finland
Phone 358 9 615 00 540 • Fax 358 9 615 00 545
Web www.nivamedical.fi • E-mail info@nivamedical.fi

MANUFACTURER'S WARRANTY

Whitehall Manufacturing Company warrants that its products are free from defects in material or workmanship under normal use and service for a period of one year from date of shipment. Whitehall's liability under this warranty shall be discharged solely by replacement or repair of defective material, provided Whitehall is notified in writing within one year from date of shipment, F.O.B. Industry, California.

This warranty does not cover installation or labor charges, and does not apply to materials which have been damaged by other causes such as mishandling or improper care or abnormal use. The repair or replacement of the defective materials shall constitute the sole remedy of the Buyer and the sole remedy of Whitehall under this warranty. Whitehall shall not be liable under any circumstances for incidental, consequential or direct charges caused by defects in the materials, or any delay in the repair or replacement thereof. This warranty is in lieu of all other warranties expressed or implied. Product maintenance instructions are issued with each fixture, and disregard or noncompliance with these instructions will constitute an abnormal use condition and void the warranty. If you have any questions or require technical assistance, please call 800-743-8219.

NOTICE TO KEEP ORIGINAL PACKAGING- Regarding warranty claims: customer must retain original packaging for one year upon receipt of product. If packaging is discarded, it is the customer's responsibility to provide adequate packaging. Any shipping claims that are a direct result of customer-provided packaging materials will be handled by the shipper.

Member of