



Mapelastic™ AquaDefense

Premium Waterproofing and Crack-Isolation Membrane



DESCRIPTION

Mapelastic AquaDefense is a premixed, advanced liquid-rubber, extremely quick-drying waterproofing and crack-isolation membrane for installation under ceramic tile or stone in residential, commercial and industrial environments. *Mapelastic AquaDefense* provides a thin, continuous barrier to protect adjacent rooms and floors below from water damage. For common problem areas like coves, corners, cracks and drains, it can be combined with MAPEI's optional *Reinforcing Fabric* or *Mapeband™* accessories (cove roll and drain flash) to provide additional protection. *Mapelastic AquaDefense* dries after about 30 to 50 minutes and is then ready to receive any MAPEI polymer or epoxy mortar. *Mapelastic AquaDefense* can be flood-tested after 12 hours of drying time, is IAPMO-listed for use as a shower-pan liner, and exceeds ANSI A118.10 and ANSI A118.12 standards.

FEATURES AND BENEFITS

- Very quick drying: Install tile after 30 to 50 minutes of drying time.
- Time-saving: Flood-test as shower-pan liner after 12 hours of drying time.
- Apply with roller or brush – easy to install over flat, curved or irregular surfaces.
- Bonds to a wide range of surfaces; convenient, user-friendly and versatile
- No odor; great for confined spaces
- Prevents in-plane floor cracks from transmitting through tile or stone

INDUSTRY STANDARDS AND APPROVALS

- ANSI: Exceeds A118.10 standard (Waterproofing Membranes for Thin-Set Ceramic Tile) and A118.12 standard (Crack-Isolation Membranes for Thin-Set Ceramic Tile)
- ASTM: C627 (Robinson) service rating for extra heavy
- IAPMO: Listed for use as shower-pan liner
- IAPMO File #3996
- ICC Evaluation Service Report ESR 3474
- Los Angeles Board of Building & Safety Commissioners File Number M-130022

LEED Points Contribution

LEED Points

MR Credit 5, Regional Materials* Up to 2 points
IEQ Credit 4.2, Low-Emitting Materials – Paints & Coatings 1 point

* Using this product may help contribute to LEED certification of projects in the categories shown above. Points are awarded based on contributions of all project materials.

WHERE TO USE

- Residential and commercial interior/exterior floors, walls and ceilings
- Industrial interior floors and walls
- Tub and shower surrounds: bathrooms; kitchens; food prep, dishwashing, servery and cafeteria areas; countertops; and laundry rooms



- Residential and commercial submerged applications: freshwater pools, fountains and water features (completely covered by ceramic tile)
 - Cantilevered balconies and decks over unoccupied space (see the "Limitations" section)
 - Balconies and decks over occupied space when used in conjunction with a primary waterproofing membrane.
 - Steam rooms when used in conjunction with a vapor barrier (refer to TCNA handbook's sections SR613 and SR614 or TTMAC 321SR).
 - In-plane crack isolation up to 1/8" (3 mm) over nonstructural cracks
 - MAPEI's *Reinforcing Fabric* is available but optional for use on coves, corners and field application.
 - Properly prepared radiant-heated substrates
 - Properly prepared unglazed ceramic tile and cement terrazzo floors, and gypsum underlayments with a minimum of 2,500 psi (17,2 MPa) in compressive strength
- Note: Existing unglazed ceramic tile must be abraded, and existing cement terrazzo must be mechanically profiled. Both must be skimcoated with an appropriate MAPEI latex- or polymer-modified mortar.
- Exterior-grade plywood (for interior residential floors and countertops in dry areas only)
 - PVC, copper, brass and stainless-steel pipe penetrations (abraded)

LIMITATIONS

- *Mapelast^{ic} AquaDefense* is not for use over structural cracks, in-plane cracks beyond 1/8" (3 mm) or where vertical out-of-plane movement occurs.
- Do not use over substrates containing asbestos, dimensionally unstable substrates such as hardwood flooring, particleboard, oriented strand board (OSB), Masonite or metal. See "Suitable Substrates" section below.
- Do not use over: Plank flooring, treated plywood, Lauan, gypsum-based floor-patching compounds, vinyl, glazed tile, laminate, fiberglass or epoxy floors, or storage tanks.
- Do not use where excessive substrate moisture and/or where negative hydrostatic pressure exists. Maximum allowable moisture is 8 lbs. per 1,000 sq. ft. (3,63 kg per 92,9 m²) per 24 hours per ASTM F1869 or up to 85% relative humidity as measured with moisture probes.
- Do not use: As a single-application roof-deck membrane, wear surface or primary waterproofing membrane on balconies or decks directly over occupied space or in storage tanks; or with premixed setting materials.
- Do not allow direct contact with solvent-based materials.

Consult MAPEI's Technical Services Department for installation recommendations regarding substrates and conditions not listed.

SUITABLE SUBSTRATES

Interior and exterior

- Fully cured concrete at least 28 days old (see "Limitations" section)
- Masonry walls of cement block or brick
- Cured cement mortar beds or leveling coats
- Cement backer units (CBUs)

Interior only

- Gypsum wallboard (walls only, in approved application areas only)

Tile Council of North America (TCNA) Statement on Deflection Criteria

Floor systems, including the framing system and subfloor panels, over which tile will be installed should be in conformance with the IRC [International Residential Code] for residential applications, the IBC [International Building Code] for commercial applications, or applicable building codes.

Note: The owner should communicate in writing to the project design professional and general contractor the "intended use" of the tile installation, in order to enable the project design professional and general contractor to make necessary allowances for the expected live load, concentrated loads, impact loads, and dead loads including the weight of the tile and setting bed. The tile installer shall not be responsible for any floor framing or subfloor installation not compliant with applicable building codes, unless the tile installer or tile contractor designs and installs the floor framing or subfloor.

SURFACE PREPARATION

- Before beginning, see MAPEI's "Surface Preparation Requirements" document in the Product Information section of the Tile & Stone Installations page on MAPEI's Website.
- All recommended substrates must be structurally sound, stable, clean and free of any substance preventing adhesion.
- Do not use chemicals (acid etching or stripping) to prepare approved substrates.
- Concrete substrates should have a concrete surface profile #2 per International Concrete Repair Institute (ICRI). Mechanically clean and profile by diamond-cup grinding or other engineer-approved method when necessary.
- Substrate and room temperatures must be 45°F to 95°F (7°C to 35°C) during and at least 24 hours after application.

MIXING

Note: Choose all appropriate safety equipment before mixing and use. Refer to the Safety Data Sheet for more information.

1. Mix by hand before using.
2. Do not dilute with any other material.
3. Promptly wash tools with water after mixing.

PRODUCT APPLICATION

- Fill all cracks, control joints and gaps in corners and coves that are greater than 1/32" (1 mm) with an appropriate filler material. Force material into crack and finish smooth with trowel. Let dry.
- MAPEI's optional *Reinforcing Fabric* may be used with *Mapelastc AquaDefense* in any of the areas shown below (see the section "Optional Use of MAPEI's *Reinforcing Fabric*").
- MAPEI's *Mapeband* accessories (cove roll and drain flashing) also may be used with *Mapelastc AquaDefense* in any of the areas shown below (see the section "Optional Use of *Mapeband* Accessories").

Pre-treat cracks, corners and coves (floor/wall intersections)

1. For expansion and control joints, see the section "Expansion and Control Joints."
2. Apply *Mapelastc AquaDefense* liquid 6" (15 cm) on both sides of cracks, corners and coves with a paintbrush or roller. Let dry to a dark-green color.
3. Apply a second coat and let dry.

Pre-treat drains

1. Review drain manufacturer's instructions for waterproof membrane installation in conjunction with these instructions.
2. Fill space between drain pipe and substrate with appropriate expansion joint materials (typically foam backer rod and sealant).
3. For drains with bolt-down collar and weep holes, loosen and remove bolts from drain flange. Abrade drain flange with sandpaper, and clean and dry thoroughly.
4. With paintbrush, apply a liberal coat over and around drain flange. Let dry to a dark-green color.
5. Apply a second coat and let dry.

Pre-treat openings around pipes and other penetrations

1. Pack/fill the openings/spaces between drain pipe and substrate with appropriate expansion joint materials (typically foam backer rod and sealant).
2. Apply *Mapelastc AquaDefense* with brush around and up onto floor or wall penetration. Let dry to a dark-green color.
3. Apply a second coat and let dry.

Complete the main area

1. Apply *Mapelastc AquaDefense* to entire area to be waterproofed (including previously coated areas such as cracks, drains and penetrations) using a 3/8" (10 mm) nap roller. Let dry to a dark-green color.
2. Apply a second coat to entire installation. Let dry 30 to 50 minutes before installing tile or stone.
3. Final dry thickness of first and second coats combined in the main area should be about 20 mils (0,5 mm) minimum (about the thickness of a credit card).
4. Inspect and, as needed, recoat pinholes or areas not completely covered. Let dry.
5. Apply bead of silicone or urethane sealant around drain flange at drain throat to join *Mapelastc AquaDefense* to the drain assembly. Leave no voids.
6. Bolt down collar to drain flange.
7. Where *Mapelastc AquaDefense* coating ends on any penetration, apply a bead of silicone or urethane sealant.

CLEANUP

- Remove excess *Mapelastc AquaDefense* (while fresh) with damp sponge, soap and warm water. Any completely dried material may be mechanically removed.

PROTECTION

- Protect from foot traffic, rain and freezing for 24 hours.
- Protect installed *Mapelastc AquaDefense* from contamination, excessive heat and extended sun exposure until tile or stone is installed.

FLOOD-TESTING (per ASTM D5957)

If flood-testing is required, allow *Mapelastc AquaDefense* to cure at least 12 hours at 73°F (23°C) and 50% relative humidity. Actual curing time depends on air and substrate temperature, substrate porosity and humidity. Expect shorter drying times in warmer conditions, longer drying times in cooler conditions.

INSTALLING CERAMIC TILE OR NATURAL STONE

1. *Mapelastc AquaDefense* is ready to receive thin-set mortars for tile or stone when dry to touch (about 30 to 50 minutes after applying second coat).
2. Let *Mapelastc AquaDefense* cure for at least 8 hours before installing medium-bed mortars (for large tile or stone), screeds (for leveling floors) or epoxy adhesives.
3. For tile and stone installations, use a MAPEI polymer-modified mortar meeting ANSI A118.4 or ANSI A118.11, or an epoxy mortar meeting ANSI A118.3. For sheet vinyl or wood-flooring installations, use an appropriate epoxy or urethane adhesive.

EXPANSION AND CONTROL JOINTS

Installation with *Mapeband*:

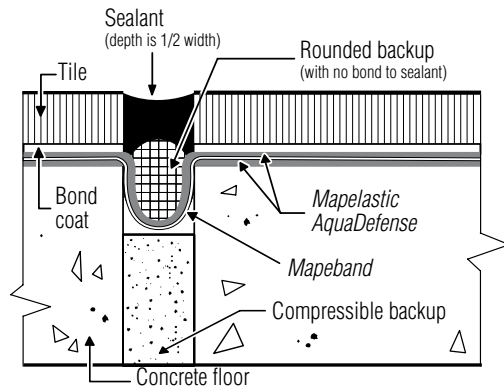

Installation with MAPEI's *Reinforcing Fabric*:

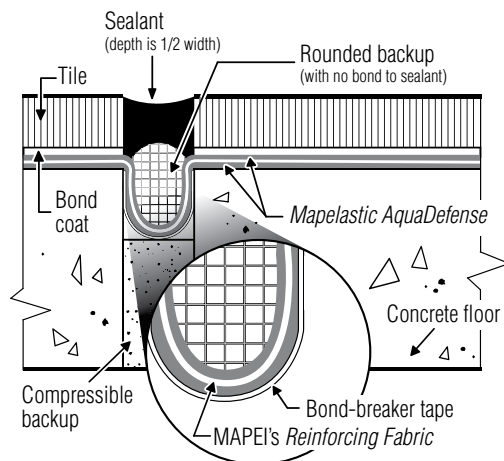

1. Do not cover any substrate expansion or control joints with mortar or tile. Provide where specified per the most current TCNA handbook for ceramic tile installation, Detail EJ-171, or TTMAC Tile Installation Manual, Detail 301MJ.
2. If waterproofing integrity is required in expansion and control joints, provide per the above drawing. MAPEI's *Reinforcing Fabric* or *Mapeband* can be embedded into the *Mapelastac AquaDefense* liquid, allowed to dry and filled with appropriate joint sealant or an expansion molding system.
3. Protect tilework with metal strips (edge metal) along both edges of structural building expansion joints.

Contact MAPEI's Technical Services Department for more information.

OPTIONAL USE OF MAPEI'S *REINFORCING FABRIC*

Select fabric size (see packaging chart)

- For coves (floor/wall intersections), allow for 2" (5 cm) of fabric on the floor and 4" (10 cm) up the wall. For cracks, control joints and vertical corners, allow for 3" (7,5 cm) of fabric on each side.
- For drains, cut desired fabric size from 38" (97-cm) wide roll. For floor or wall penetrations, use 6" (15-cm) wide, 38" (97-cm) wide or a combination of both.
- For large areas, the 38" (97-cm) wide roll is recommended.

Cut fabric to size

Cut all required pieces. Set aside.

Pre-treat cracks, control joints, corners, coves, drains, and floor and wall penetrations

1. Apply *Mapelastac AquaDefense* as described in the "Pre-treat" sections above.
2. Lay pre-cut pieces of fabric into wet *Mapelastac AquaDefense*. Use brush to press fabric into corners until liquid comes through fabric. Work out any wrinkles or bubbles.
3. While fabric is wet, apply additional *Mapelastac AquaDefense* over fabric until completely covered to create void-free surface. Let dry to a dark-green color.
4. Apply a second coat and let dry.

Install fabric on main area

1. Apply the first coat of *Mapelastac AquaDefense* (including areas previously coated) using a 3/8" (10-mm) nap roller.
2. Place fabric into wet liquid on floor. Using a roller, apply pressure to fabric, working out wrinkles or bubbles while forcing *Mapelastac AquaDefense* to come through fabric. Overlap seams and ends of fabric 2" (5 cm). While still wet, apply additional *Mapelastac AquaDefense* over fabric until completely covered, creating a void-free surface. Let dry completely to a dark-green color.
3. Apply a second coat of *Mapelastac AquaDefense* to entire area. Let dry.
4. Give a final inspection, looking for pinholes, areas not completely covered and other defects.
5. Recoat as needed. Let dry to a dark-green color.
6. Apply a bead of commercial-grade silicone or urethane sealant between the membrane and the drain flange, about 1/2" (12 mm) in from the drain opening.
7. Bolt the drain collar into place while sealant is still fresh.
8. Install ceramic tile or natural stone per the above section "Installing ceramic tile or natural stone."

Product Performance Properties

Laboratory Tests	Results
pH	9
Viscosity	Approximately 30,000 cps
Density	1,3 g per mL
Weight	10.9 lbs. per U.S. gal. (1,3 kg per L)

Shelf Life and Application Properties

Shelf life (<i>Mapelastic AquaDefense</i>)	2 years when stored in original unopened container
Shelf life (optional <i>Reinforcing Fabric</i>)	Unlimited (when stored in original unopened box)
Flash point (Seta flash)	Nonflammable
Color	Medium green when wet; dark green when dry
Drying time between first and second coats	When dark green and dry to the touch
Drying time after second coat (before applying ceramic tile or stone)	About 30 to 50 minutes (when dark green and dry to the touch)
Drying time before flood-testing	After 12 hours at 73°F (23°C) and 50% relative humidity
Final dry thickness (2 coats)	About 20 mils (0,5 mm) minimum (about credit-card thickness)
Freeze/thaw stability (liquid)	Up to 5 cycles at 32°F (0°C)
Storage	Store in cool, dry place. Protect from freezing.

Packaging (*Mapelastic AquaDefense*)

Product Code	Size	Approximate Coverage (per 2 coats)*
01953	Pail: 1 U.S. gal. (3,79 L) – 4-pack	60 sq. ft. (5,57 m ²)
01963	Pail: 3.5 U.S. gals. (13,2 L)	210 sq. ft. (19,5 m ²)
01968	Pail: 5 U.S. gals. (18,9 L)	300 sq. ft. (27,9 m ²)
01977	Drum: 55 U.S. gals. (208 L) – special order	3,300 sq. ft. (307 m ²)

* Coverage shown is for estimating purposes only. Actual jobsite coverage may vary according to substrate conditions, concrete profile and porosity, type of equipment used, thickness applied, handling and application procedures.

Packaging (optional *Reinforcing Fabric*)

Product Code	Size	Approximate Coverage
0170004	Roll: 6" x 75' (15 cm x 22,9 m), 8 per box – To reinforce over cracks, control joints, corners, coves and floor/wall penetrations	37.5 sq. ft. (3,48 m ²) per roll
0170007	Roll: 38" x 75' (97 cm x 22,9 m), 1 per box – To reinforce around drains or main area to be waterproofed	237.5 sq. ft. (22,1 m ²) per roll

Packaging (*Mapeband* waterproofing accessories)

Product Code	Size and Color
02101000	Drain flashing (blue): 13.5" x 13.5" (34.2 x 34.2 cm)
02401000	Cove roll (blue): 4.75" x 163 ft. (12 cm x 49,7 m)

Mapelastic[™] AquaDefense



OPTIONAL USE OF MAPEBAND ACCESSORIES

1. MAPEI's *Mapeband* accessories (cove roll and drain flashing) are waterproof, vapor-proof thin, elastic, deformable, rubber-coated fabric pieces that are fully compatible with *Mapelastic AquaDefense* and provide the ultimate in "change-of-plane" waterproofing protection for coves, corners and drains. *Mapeband* accessories are ideal for environments requiring waterproofing but also where temperature extremes, freeze/thaw conditions, vibrations, etc., can cause waterproofing problems.
2. *Mapeband* cove roll can be used in place of MAPEI's *Reinforcing Fabric* on coves, corners and control joints. The "felt side" should face into the corner.
3. *Mapeband* drain flashing can be used in place of MAPEI's *Reinforcing Fabric* on drains. The "felt side" should face down.
4. See *Mapeband*'s Technical Data Sheet for installation details.

RELATED DOCUMENTS

Reference Guide: Surface Preparation Requirements for tile and stone installation systems	RG T0309*
---	-----------

* At www.mapei.com

Refer to the SDS for specific data related to VOCs, health and safety, and handling of product.

STATEMENT OF RESPONSIBILITY

Before using, user shall determine the suitability of the product for its intended use and user alone assumes all risks and liability whatsoever in connection therewith.

ANY CLAIM SHALL BE DEEMED WAIVED UNLESS MADE IN WRITING TO US WITHIN FIFTEEN (15) DAYS FROM DATE IT WAS, OR REASONABLY SHOULD HAVE BEEN, DISCOVERED.

We proudly support the following industry organizations:



MAPEI Headquarters of the Americas

1144 East Newport Center Drive
Deerfield Beach, Florida 33442
Phone: 1-888-US-MAPEI
(1-888-876-2734)

Technical Services

1-800-992-6273 (U.S. and Puerto Rico)
1-800-361-9309 (Canada)

Customer Service

1-800-42-MAPEI (1-800-426-2734)

Services in Mexico

0-1-800-MX-MAPEI (0-1-800-696-2734)

Edition Date: September 24, 2013

PR: 5593 MKT: 6943

For the most current BEST-BACKED[™] product data and warranty information, visit www.mapei.com.

All Rights Reserved. Printed in the USA. © 2013 MAPEI Corporation.