

TECHNICAL GUIDE

ADD - ON COILS FOR USE WITH SPLIT-SYSTEM COOLING & HEAT PUMPS

MODELS: MC, PC, FC, HD, HC, UC
600 - 2000 CFM 1.5 - 5 TON COILS



HORIZONTAL
DUCT
HD



FULL CASED
MULTI-POSITION
MC



UPFLOW UNCASED
UC



UPFLOW/DOWNFLOW
FULL CASED
FC



HORIZONTAL CASED
HC



UPFLOW
PARTIAL CASED
PC



Due to continuous product improvement, specifications are subject to change without notice.

Visit us on the web at www.york.com for the most up-to-date technical information.

Additional rating information can be found at www.ariprimer.net.

DESCRIPTION

These cooling and heat pump coils are designed to be installed with UPG furnaces and to be matched with UPG cooling and heat pump outdoor units. All UPG coils utilize a TXV to provide our customers with the optimum performance and refrigerant control required for 13+ SEER systems. Coils can be ordered with a R22 TXV factory installed that can be easily converted to R410A by changing the bolt-on TXV.

“Flex-coils” are also available without a factory installed metering device. For added application flexibility a R22 or R410A TXV is installed, on “Flex-coils”, in the field to meet your refrigerant choice.

Upflow/Downflow Coils Full Cased and Partial Cased Coils – Designed for high-efficiency to match any system, full cased in the upflow or downflow and the partial cased in the upflow only application.

Multi-Position Coils - Designed for high-efficiency like the upflow/downflow coil but with the added flexibility that allows it to be installed any position, upflow, downflow, horizontal right or left. This coil can be easily applied to our furnace and modular air handler in any configuration.

Horizontal Duct Coils - Available for both cooling and heat pump dedicated horizontal, slab coil, applications. Field transition may be required.

Dedicated Horizontal Cased Coils – These coils are cooling only or heat pump approved for horizontal furnace or modular air handler applications. Unlike the horizontal duct coils these cased coils match the dimensions of the furnace or modular blower.

FEATURES

Thermal Expansion Valve - Provides flexibility to convert any coil to R22 or R410A refrigerant. A true bolt-on TXV, valve assembly and equalizer tube are bolt-on, no brazing required. TXV and sensing bulb are mounted inside the cased coil cabinet. (Must be field supplied for all “Flex-coils”)

MicroBlue™ Coated Fins - All coils are treated with a **MicroBlue™** Hydrophilic coating to enhance the removal of condensate during the refrigeration cycle and reduce the possibility of water blow-off. The **MicroBlue™** coating also reduces the growth of germ causing microbes.

Insulated Cabinet - All evaporator coil cabinets are thermally insulated with foil faced insulation to prevent sweating.

Internally Clean - All evaporator coils are factory leak-tested, dehydrated, sealed and shipped with a holding charge. The suction and liquid lines are sealed with rubber plugs, no cutting of connection stubs to attach line set.

Durable Finish Inside and Out - Coil casings are made of pre-painted steel. The pre-treated flat galvanized steel provides a better paint to steel bond, which resists corrosion and rust creep. All internal metal parts are made of G90 pre-painted steel i.e. triangular plates, top plates, horizontal supports etc. (Coil header plates are non-painted due to the brazing process during production.)

Optimum Heat Transfer - Using the latest in heat transfer technology, staggered rows of copper tubes are mechanically expanded into aluminum fins to provide optimum air to surface contact for ample moisture removal as well as high performance ratings.

ACCESSORIES

Refer to Price Manual for specific model numbers.

TXV Kits - Thermal expansion valve kits are available for “Flex-coil” applications and converting R22 to R410A refrigerant or as a service replacement. All TXV kits are non-braze, all connections are bolt-on including the valve assembly and equalizer tube. (No orifice or any other metering device is to be used in conjunction with the TXV).

Coil Casing Without Coil – Coil casings are available in each width that can be installed with the furnace or modular air handler during initial installation. This option is available to allow the installer the flexibility to install the coil at a later date without duct modifications.

COOLING CAPACITY - Coil Only*

Model	Rated CFM	Entering Air °F (Wet Bulb)	MBH @ Evaporator Temperature and Corresponding Pressure °F / PSIG			
			35 / 61.5	40 / 68.5	45 / 76.0	50 / 84.0
UPFLOW "A" TYPE						
FC18A PC18A	675	72	25.3	23.1	20.6	17.9
		67	23.4	21.1	18.7	16.1
		62	19.2	12.0	18.7	12.4
		57	15.6	13.5	11.3	8.8
FC18B PC18B	850	72	28.1	25.7	22.9	19.9
		67	26.0	23.5	20.8	17.9
		62	21.3	18.9	16.4	13.7
		57	17.3	15.0	12.6	9.8
FC24A PC24A	675	72	35.6	32.5	29.0	25.2
		67	32.9	29.7	26.3	22.7
		62	27.0	23.9	20.7	17.4
		57	21.9	19.0	15.9	12.4
FC24B PC24B	850	72	35.6	32.5	29.0	25.2
		67	32.9	29.7	26.3	22.7
		62	27.0	23.9	20.7	17.4
		57	21.9	19.0	15.9	12.4
FC30A PC30A FC30B PC30B	1025	72	38.9	35.4	31.6	27.6
		67	33.9	30.3	26.8	23.0
		62	27.3	23.7	22.5	18.0
		57	22.6	20.1	17.5	14.8
FC35B PC35B FC35C PC35C	1025	72	46.1	41.9	37.4	33.0
		67	36.9	32.6	28.6	24.3
		62	28.9	24.2	26.4	19.7
		57	24.7	22.9	21.1	19.7
FC36A PC36A	1150	72	46.0	41.9	37.4	32.9
		67	36.8	32.5	28.5	24.2
		62	28.8	24.1	26.4	19.6
		57	24.7	22.9	21.1	19.6
FC36B PC36B FC36C PC36C	1250	72	51.1	46.5	41.5	36.6
		67	40.9	36.1	31.7	26.9
		62	32.0	26.8	29.3	21.8
		57	27.4	25.4	23.4	21.8
FC42B PC42B FC42C PC42C	1400	72	86.6	74.5	62.0	49.0
		67	69.4	58.2	47.4	36.3
		62	54.1	43.0	35.1	29.3
		57	46.5	40.7	35.1	29.3
FC48C PC48C	1620	72	99.4	85.5	71.2	56.2
		67	79.6	66.8	54.4	41.6
		62	62.1	49.4	40.2	33.7
		57	53.3	46.7	40.2	33.7
FC60C PC60C FC60D PC60D	1850	72	118.7	100.0	81.1	61.5
		67	95.0	78.4	61.9	45.4
		62	74.0	58.0	45.7	36.7
		57	63.6	54.8	45.7	36.7

* - See Condensing Unit or Heat Pump Technical Guide for Total Cooling Capacity and Sensible Capacity.

COOLING CAPACITY - COIL ONLY*

Model Coil	Rated CFM	Entering Air °F (Wet Bulb)	MBH@ Evaporator Temperature and Corresponding Pressure °F / PSIG			
			35 / 61.5	40 / 68.5	45 / 76.0	50 / 84.0
FULL-CASED "A" TYPE MULTI-POSITION						
MC18A	550	72	25.8	23.5	21.0	18.2
		67	23.7	21.5	19.0	16.4
		62	19.5	17.3	14.9	12.6
		57	15.8	13.5	11.5	9.0
MC18B	650	72	28.7	26.1	23.3	20.2
		67	26.4	23.9	21.1	18.2
		62	21.6	19.2	16.6	14.0
		57	17.5	15.2	12.8	10.0
MC24A MC24B	850	72	36.3	33.0	29.5	25.6
		67	33.4	30.2	26.7	23.1
		62	27.4	24.3	21.0	17.7
		57	22.2	19.3	16.2	12.6
MC30A MC30B	1025	72	41.5	37.8	33.7	29.5
		67	36.2	32.4	28.6	24.5
		62	29.1	25.3	24.0	19.2
		57	24.1	21.5	18.7	15.8
MC35B MC35C	1025	72	46.9	42.7	38.2	33.6
		67	37.6	33.2	29.1	24.7
		62	29.3	24.6	26.9	20.0
		57	25.2	23.3	21.5	20.0
MC36A	1150	72	46.8	42.6	38.1	33.6
		67	37.5	33.1	29.1	24.7
		62	29.3	24.6	26.8	20.0
		57	25.1	23.2	21.4	20.0
MC36B	1250	72	52.0	47.3	42.3	37.3
		67	41.7	36.8	32.3	27.4
		62	32.5	27.3	29.8	22.2
		57	27.9	25.8	23.8	22.2
MC36C	1250	72	53.4	48.6	43.4	38.3
		67	42.8	37.8	33.1	28.2
		62	33.4	28.1	30.6	22.8
		57	28.7	26.5	24.5	22.8
MC42B MC42C	1400	72	88.4	76.0	63.3	50.0
		67	70.8	59.4	48.4	37.0
		62	55.2	43.9	35.8	29.9
		57	47.4	41.5	35.8	29.9
MC48C MC48D	1650	72	100.5	86.4	72.0	56.8
		67	80.4	67.5	55.0	42.1
		62	62.7	49.9	40.7	34.0
		57	53.9	47.2	40.7	34.0
MC60D	1825	72	119.9	101.0	80.0	62.2
		67	96.0	79.2	62.6	45.8
		62	74.8	58.6	46.2	37.0
		57	64.3	55.4	46.2	37.0
MC61D	2000	72	124.8	105.2	85.3	64.7
		67	99.9	82.5	65.2	47.7
		62	77.9	61.1	48.1	38.6
		57	66.9	57.7	48.1	38.6

* See Condensing Unit or Heat Pump Technical Guide for Total Cooling Capacity and Sensible Capacity.

COOLING CAPACITY - Coil Only*

MODEL	RATED CFM	ENTERING AIR °F (Wet Bulb)	MBH @ Evaporator Temperature and Corresponding Pressure °F/ PSIG			
			35 / 61.5	40 / 68.5	45 / 76.0	50 / 84.0
HORIZONTAL DUCT TYPE						
HD24A	815	72	35.3	32.4	28.7	24.9
		67	32.6	29.4	26.0	22.5
		62	26.7	23.7	20.5	17.2
		57	21.7	18.8	15.7	12.3
HD36B	1192	72	57.9	52.7	47.1	41.5
		67	46.4	41.1	35.9	30.4
		62	36.2	30.4	26.5	24.7
		57	31.1	28.7	26.5	24.7
HD48C	1610	72	83.4	71.7	59.7	47.1
		67	66.8	56.1	45.6	34.9
		62	52.1	41.5	33.7	28.3
		57	44.7	39.2	33.7	28.3
HD60D	2100	72	133.0	112.4	90.9	69.2
		67	106.5	87.9	69.4	50.0
		62	83.0	65.0	51.3	41.1
		57	71.2	61.4	51.3	41.1

* See Condensing Unit or Heat Pump Technical Guide for Total Cooling Capacity and Sensible Capacity.

Notes:

- MC coils available with a factory installed horizontal drain pan option (H).

COOLING CAPACITY - COIL ONLY*

Model	Rated CFM	Entering Air °F (Wet Bulb)	MBH @ EVAPORATOR TEMPERATURE AND CORRESPONDING PRESSURE °F / PSIG			
			35/61.5	40/68.5	45/76.0	50/84.0
HC18A	600	72	26.4	24.0	21.5	18.6
		67	24.3	22.0	19.4	16.8
		62	20.0	17.7	15.3	12.9
		57	16.1	14.0	11.8	9.2
HC30A	1000	72	42.7	38.9	34.7	30.6
		67	34.3	30.3	26.5	22.5
		62	26.7	22.5	24.5	19.8
		57	22.9	21.2	19.6	18.3
HC36B	1200	72	73.4	63.1	52.5	41.5
		67	58.8	49.3	40.2	30.7
		62	45.8	36.4	29.7	24.8
		57	39.3	34.4	28.1	23.2
HC42C	1400	72	84.9	73.0	60.1	48.1
		67	68.0	58.9	46.5	35.6
		62	53.1	42.2	34.4	28.8
		57	45.5	40.0	32.0	26.7
HC60C	1800	72	112.8	95.0	77.0	58.4
		67	90.3	74.5	58.8	43.1
		62	70.3	55.1	43.4	34.9
		57	60.4	52.1	40.4	31.9

* See Condensing Unit or Heat Pump Technical Guide for Total Cooling Capacity and Sensible Capacity.

COOLING CAPACITY - COIL ONLY*

Model Coil	Rated CFM	Entering Air °F (Wet Bulb)	MBH@ Evaporator Temperature and Corresponding Pressure °F / PSIG			
			35 / 61.5	40 / 68.5	45 / 76.0	50 / 84.0
uncased upflow						
UC18A UC18B	60	72	23.3	21.3	19.0	17.5
		67	21.5	19.5	17.3	14.9
		62	17.7	15.6	13.5	11.4
		57	14.4	12.4	10.4	8.0
UC24A UC24B	800	72	27.4	25.0	22.3	19.4
		67	25.3	22.9	20.3	17.5
		62	20.8	18.4	15.9	13.4
		57	16.9	14.6	12.2	9.4
UC30A UC30B	1000	72	35.2	32.0	28.6	24.8
		67	32.4	28.6	25.3	21.9
		62	26.6	23.6	21.5	18.7
		57	25.2	22.7	20.2	17.6
UC36A	1150	72	46.8	42.7	37.9	33.0
		67	43.1	39.2	34.9	30.4
		62	35.3	32.1	28.6	24.9
		57	33.3	26.9	26.9	23.4
UC36B UC36C	1200	72	49.3	44.9	39.9	34.7
		67	45.4	41.3	36.7	32.0
		62	37.2	33.8	30.1	26.2
		57	35.0	28.3	28.3	24.6
UC42B UC42C	1400	72	86.7	73.0	59.2	44.9
		67	69.4	57.2	45.2	33.1
		62	54.0	42.3	33.4	26.8
		57	46.4	40.0	33.4	26.8
UC48C UC48D	1600	72	62.4	56.8	50.5	44.4
		67	57.4	53.2	46.5	40.5
		62	47.1	42.8	38.1	33.2
		57	44.3	40.3	35.8	31.2
UC60C UC60D	1800	72	95.4	82.1	68.4	54.0
		67	76.4	64.1	52.2	39.9
		62	59.6	47.4	38.6	32.4
		57	51.2	44.8	38.6	32.4

* See Condensing Unit or Heat Pump Technical Guide for Total Cooling Capacity and Sensible Capacity.

APPLICATION FACTOR-RATED CFM VS. ACTUAL CFM

% OF RATED AIR FLOW	80%	90%	RATED CFM	110%	120%
CAPACITY FACTOR	0.96	0.98	1.00	1.02	1.03

NOTE: Do not exceed minimum/maximum CFM limits shown under Air Flow Data.

APPLICATION LIMITATIONS

These units must be installed in accordance with all national and local safety codes.

Air flow must be within the minimum and maximum limits approved for electric heat, evaporator coils and outdoor units.

Entering Air Temperature Limits			
Wet Bulb Temp. °F		Dry Bulb Temp. °F	
Min.	Max.	Min.	Max.
57	72	65	95

STATIC PRESSURE VS. AIRFLOW (BASED ON WET COIL)

UPFLOW CASED "A" TYPE

Model	Airflow	Wet Coil
FC18A PC18A	600	0.16
	800	0.23
	1000	0.30
FC18B PC18B	600	0.14
	800	0.20
	1000	0.26
FC24A PC24A	600	0.15
	800	0.21
	1000	0.27
FC24B PC24B	600	0.13
	800	0.18
	1000	0.23
FC30A PC30A	800	0.21
	1000	0.27
	1200	0.33
FC30B PC30B	800	0.18
	1000	0.23
	1200	0.29
FC35B PC35B	800	0.16
	1000	0.22
	1200	0.29
FC35C PC35C	800	0.14
	1000	0.20
	1200	0.27
FC36A PC36A	1000	0.24
	1200	0.32
	1400	0.40
FC36B PC36B	1000	0.15
	1200	0.22
	1400	0.28
FC36C PC36C	1000	0.10
	1200	0.15
	1400	0.20
FC42B PC42B	1200	0.21
	1400	0.28
	1600	0.34
FC42C PC42C	1800	0.40
	1200	0.14
	1400	0.19
FC48C PC48C	1600	0.24
	1800	0.28
	2000	0.32
FC48D PC48D	2200	0.38
	1600	0.25
	1800	0.30
FC60C PC60C	2000	0.35
	2200	0.40
	2400	0.46
FC60D PC60D	1600	0.25
	1800	0.30
	2000	0.35
FC60D PC60D	2200	0.40
	1600	0.28
	1800	0.33
FC60D PC60D	2000	0.38
	2200	0.43
	FC60D PC60D	1600
1800		0.27
2000		0.32
FC60D PC60D	2200	0.38

HORIZONTAL - DUCT TYPE

Model	Airflow	Wet Coil
HD24A	600	0.02
	800	0.09
	1000	0.19
HD36B	1000	0.19
	1200	0.28
	1400	0.38
HD48C	1200	0.14
	1400	0.19
	1600	0.25
HD60D	1800	0.32
	1600	0.16
	1800	0.20
HD60D	2000	0.25
	2200	0.30

HORIZONTAL CASED

Model	Airflow	Wet Coil
HC18A	600	0.07
	800	0.12
	1000	0.19
HC30A	800	0.21
	900	0.25
	1150	0.30
HC36B	1200	0.31
	1000	0.20
	1100	0.24
HC42C	1200	0.27
	1300	0.30
	1400	0.25
HC60C	1500	0.28
	1550	0.30
	1600	0.33
HC60C	1700	0.25
	1800	0.28
	1850	0.30
	1900	0.31
HC60C	2000	0.34

CASED "A" TYPE MULTI-POSITION

Model	Airflow	Wet Coil
MC18A	600	0.22
	800	0.29
	1000	0.36
MC18B	600	0.20
	800	0.26
	1000	0.32
MC24A	600	0.21
	800	0.27
	1000	0.33
MC24B	600	0.19
	800	0.24
	1000	0.29
MC30A	600	0.21
	800	0.27
	1000	0.33
MC30B	600	0.19
	800	0.24
	1000	0.29
MC35B	600	0.22
	800	0.26
	1000	0.34
MC35C	600	0.20
	800	0.24
	1000	0.32
MC36A	800	0.22
	1000	0.30
	1200	0.38
MC36B	800	0.15
	1000	0.21
	1200	0.28
MC36C	1000	0.16
	1200	0.21
	1400	0.26
MC42B	1200	0.27
	1400	0.34
	1600	0.40
MC42C	1200	0.20
	1400	0.25
	1600	0.30
MC48C	1200	0.24
	1400	0.30
	1600	0.35
MC48D	1200	0.20
	1400	0.26
	1600	0.31
MC60D	1600	0.27
	1800	0.33
	2000	0.38
MC61D	1600	0.24
	1800	0.29
	2000	0.35
	2200	0.40

UNCASED UPFLOW - "A" TYPE

Model	Airflow	Wet Coil
UC18A	600	0.16
	800	0.23
	1000	0.30
UC18B	600	0.14
	800	0.20
	1000	0.26
UC24A	600	0.15
	800	0.21
	1000	0.27
UC24B	600	0.13
	800	0.18
	1000	0.23
UC30A	800	0.21
	1000	0.27
	1200	0.33
UC30B	800	0.18
	1000	0.23
	1200	0.29
UC36A	1000	0.24
	1200	0.32
	1400	0.40
UC36B	1000	0.15
	1200	0.22
	1400	0.28
UC36C	1000	0.10
	1200	0.15
	1400	0.20
UC42B	1200	0.21
	1400	0.28
	1600	0.34
UC42C	1200	0.14
	1400	0.19
	1600	0.24
UC48C	1200	0.18
	1400	0.24
	1600	0.29
UC48D	1200	0.14
	1400	0.20
	1600	0.25
UC60C	1600	0.28
	1800	0.33
	2000	0.38
UC60D	2200	0.43
	1600	0.21
	1800	0.27
	2000	0.32
	2200	0.38

**PHYSICAL DATA
CASED (FC) AND PARTIAL CASED (PC) UPFLOW "A" TYPE**

Model	Application	Refrig. Conn. Types	Face Area (Sq. Ft.)	Rows Deep	Fin Per In.	Coil Size	Tube Geometry	Tube Dia.	Fin Type	TXV	Operating Weight (Lbs.)
FC18A3XN1 PC18A3XN1	Cooling/ Heat Pump	Sweat	3.4	2	14	(2) 14 x 17.5	1 x 0.866	3/8	Enhanced	None	42
FC18A2AN1 PC18A2AN1											36
FC18B3XN1 PC18B3XN1			2A	42							
				36							
FC18B2AN1 PC18B2AN1			None	44							
				37							
FC24A3XN1 PC24A3XN1			2A	44							
				37							
FC24A2AN1 PC24A2AN1			None	46							
				40							
FC24B3XN1 PC24B3XN1			2A	46							
				40							
FC24B2AN1 PC24B2AN1			None	50							
				42							
FC30A3XN1 PC30A3XN1			2A	50							
				42							
FC30A2AN1 PC30A2AN1			None	46							
				40							
FC30B3XN1 PC30B3XN1			2A	46							
				40							
FC30B2AN1 PC30B2AN1			None	50							
				42							
FC35B3XN1 PC35B3XN1			2A	53							
				45							
FC35C3XN1 PC35C3XN1			None	55							
				46							
FC36A3XN1 PC36A3XN1			2A	51							
				44							
FC36A2AN1 PC36A2AN1			None	51							
				44							
FC36B3XN1 PC36B3XN1			2A	53							
				45							
FC36B2AN1 PC36B2AN1			None	53							
				45							
FC36C3XN1 PC36C3XN1			2A	55							
				46							
FC36C2AN1 PC36C2AN1			None	55							
				46							
FC42B3XN1 PC42B3XN1			2A	62							
				50							
FC42B2CN1 PC42B2CN1	None	62									
		50									
FC42C3XN1 PC42C3XN1	2C	64									
		54									
FC42C2CN1 PC42C2CN1	None	64									
		54									
FC48C3XN1 PC48C3XN1	2C	65									
		56									
FC48C2CN1 PC48C2CN1	None	65									
		56									
FC48D3XN1 PC48D3XN1	2C	73									
		58									
FC48D2CN1 PC48D2CN1	None	73									
		58									
FC60C3XN1 PC60C3XN1	2C	65									
		58									
FC60C2CN1 PC60C2CN1	None	65									
		58									
FC60D3XN1 PC60D3XN1	2C	78									
		60									
FC60D2CN1 PC60D2CN1	None	78									
		60									

HORIZONTAL - DUCT TYPE

Model	Application	Refrig. Conn. Types	Face Area (Sq. Ft.)	Rows Deep	Fin Per In.	Coil Size	Tube Geometry	Tube Dia.	Fin Type	TXV	Operating Weight (Lbs.)
HD24A3XH1	Cooling / Heat Pump	Sweat	3.67	3	12	22 x 24	1 x 0.866	3/8	Enhanced	None	40
HD24A2AH1										2A	
HD36B3XH1			3.67	3	12	22 x 24				None	40
HD36B2AH1										2A	
HD48C3XH1			4.33	3	12	26 x 24				None	46
HD48C2CH1										2C	
HD60D3XH1			5.83	3	12	28 x 30				None	54
HD60D2CH1										2C	

UNCASED UPFLOW - "A" TYPE

Model	Application	Refrig. Conn. Types	Face Area (Sq. Ft.)	Rows Deep	Fin Per In.	Coil Size	Tube Geometry	Tube Dia.	Fin Type	TXV	Operating Weight (Lbs.)
UC18A3XN1	Cooling / Heat Pump	Sweat	3.67	2	14	(2) 16 x 16.5	1 x 0.866	3/8	Enhanced	None	18
UC18A2AN1										2A	
UC18B3XN1			3.67	2	14	(2) 16 x 16.5				None	20
UC18B2AN1										2A	
UC24A3XN1			4.58	2	14	(2) 20 x 16.5				None	22
UC24A2AN1										2A	
UC24B3XN1			4.58	2	14	(2) 20 x 16.5				None	23
UC24B2AN1										2A	
UC30A3XN1			4.58	2	14	(2) 20 x 16.5				None	22
UC30A2AN1										2A	
UC30B3XN1			4.58	2	14	(2) 20 x 16.5				None	23
UC30B2AN1										2A	
UC36A3XN1			5.04	2	14	(2) 22 x 16.5				None	25
UC36A2AN1										2A	
UC36B3XN1			5.04	2	14	(2) 22 x 16.5				None	28
UC36B2AN1										2A	
UC36C3XN1			5.04	2	14	(2) 22 x 16.5				None	30
UC36C2AN1										2A	
UC42B3XN1			5.96	2	14	(2) 26 x 16.5				None	34
UC42B2CN1										2C	
UC42C3XN1			5.96	2	14	(2) 26 x 16.5				None	36
UC42C2CN1										2C	
UC48C3XN1			5.50	3	12	(2) 24 x 16.5				None	38
UC48C2CN1										2C	
UC48D3XN1			5.50	3	12	(2) 24 x 16.5				None	42
UC48D2CN1										2C	
UC60C3XN1			5.96	3	12	(2) 26 x 16.5				None	42
UC60C2CN1										2C	
UC60D3XN1			5.96	3	12	(2) 26 x 16.5				None	45
UC60D2CN1										2C	

FULL CASED "A" TYPE MULTI-POSITION

Model	Application	Refrig. Conn. Types	Face Area (Sq. Ft.)	Rows Deep	Fin Per In.	Coil Size	Tube Geometry	Tube Dia.	Fin Type	TXV	Operating Weight (Lbs.)
MC18A3XH1	Cooling / Heat Pump	Sweat	3.40	2	14	(2) 14 x 17.5	1 x 0.866	3/8	Enhanced	None	53
MC18A2AH1										2A	
MC18B3XH1			3.40	2	14	(2) 14 x 17.5				None	53
MC18B2AH1										2A	
MC24A3XH1			4.38	2	14	(2) 18 x 17.5				None	56
MC24A2AH1										2A	
MC24B3XH1			4.38	2	14	(2) 18 x 17.5				None	56
MC24B2AH1										2A	
MC30A3XH1			4.38	2	14	(2) 18 x 17.5				None	56
MC30A2AH1										2A	
MC30B3XH1			4.38	2	14	(2) 18 x 17.5				None	56
MC30B2AH1										2A	
MC35B3XH1			3.9	3	12	(2) 16 x 17.5				None	65
MC35C3XH1										None	
MC36A3XH1			4.86	2	14	(2) 20 x 17.5				None	64
MC36A2AH1										2A	
MC36B3XH1			4.86	2	14	(2) 20 x 17.5				None	65
MC36B2AH1										2A	
MC36C3XH1			4.86	2	14	(2) 20 x 17.5				None	65
MC36C2AH1										2A	
MC42B3XH1			5.83	2	14	(2) 24 x 17.5				None	72
MC42B2CH1										2C	
MC42C3XH1			5.83	2	14	(2) 24 x 17.5				None	72
MC42C2CH1										2C	
MC48C3XH1			5.35	3	12	(2) 22 x 17.5				None	82
MC48C2CH1										2C	
MC48D3XH1			5.35	3	12	(2) 22 x 17.5				None	82
MC48D2CH1										2C	
MC60D3XH1			5.83	3	12	(2) 24 x 17.5				None	86
MC60D2CH1										2C	
MC61D3XH1			6.80	3	12	(2) 28 x 17.5				None	98
MC61D2CH1										2C	

Note: MC coils available with a factory installed horizontal drain pan option (H).

HORIZONTAL CASED TYPE

Model	Application	Refrig. Conn. Types	Face Area (Sq. Ft.)	Rows Deep	Fin Per In.	Coil Size	Tube Geometry	Tube Dia.	Fin Type	TXV	Operating Weight (Lbs.)
HC18A3XH1	Cooling / Heat Pump	Sweat	3.40	2	14	(2) 14 x 17.5	1 x 0.866	3/8	Enhanced	None	40
HC18A2AH1										2A	
HC30A3XH1			3.40	3	12	(2) 14 x 17.5				None	49
HC30A2AH1										2A	
HC36B3XH1			3.88	3	12	(2) 16 x 17.5				None	54
HC36B2AH1										2A	
HC42C3XH1			4.86	3	12	(2) 20 x 17.5				None	66
HC42C2CH1										2C	
HC60D3XH1			5.83	3	12	(2) 24 x 17.5				None	76
HC60D2CH1										2C	

DIMENSIONS

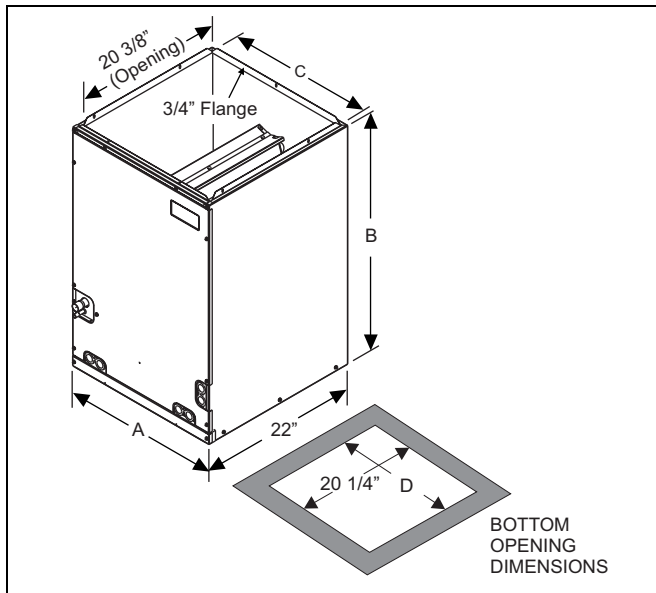

Coil - MC

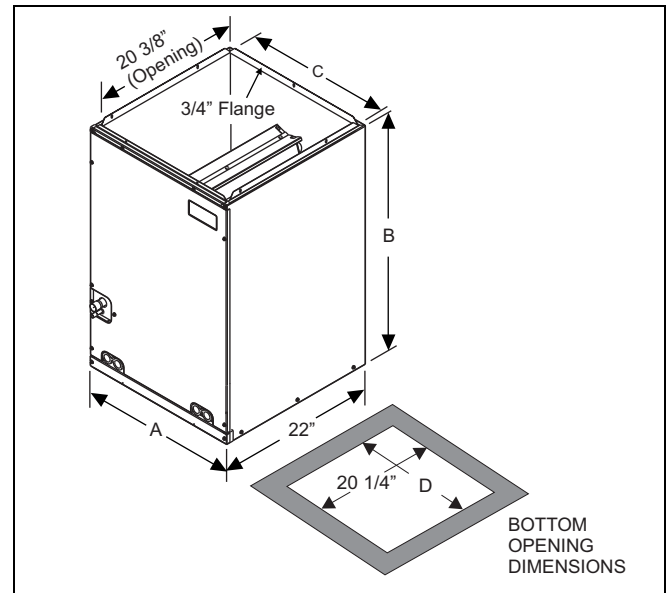

Coil - FC

Dimensions - MC Coils

Model	A	B	C	D	Refrigerant Line Size*		Factory Installed TXV (R22)
					Liquid	Vapor	
MC18A2AH1	14.5	22	13 3/8	13.5	3/8	3/4	2A
MC18A3XH1	14.5	22	13 3/8	13.5	3/8	3/4	None
MC18B2AH1	17.5	22	16 3/8	16.5	3/8	3/4	2A
MC18B3XH1	17.5	22	16 3/8	16.5	3/8	3/4	None
MC24A2AH1	14.5	26.5	13 3/8	13.5	3/8	3/4	2A
MC24A3XH1	14.5	26.5	13 3/8	13.5	3/8	3/4	None
MC24B2AH1	17.5	26.5	16 3/8	16.5	3/8	3/4	2A
MC24B3XH1	17.5	26.5	16 3/8	16.5	3/8	3/4	None
MC30A2AH1	14.5	26.5	13 3/8	13.5	3/8	3/4	2A
MC30A3XH1	14.5	26.5	13 3/8	13.5	3/8	3/4	None
MC30B2AH1	17.5	26.5	16 3/8	16.5	3/8	3/4	2A
MC30B3XH1	17.5	26.5	16 3/8	16.5	3/8	3/4	None
MC35B3XH1	17.5	22	16 3/8	16.5	3/8	3/4	None
MC35C3XH1	21	26.5	19 7/8	20	3/8	3/4	None
MC36A2AH1	14.5	26.5	13 3/8	13.5	3/8	7/8	2A
MC36A3XH1	14.5	26.5	13 3/8	13.5	3/8	7/8	None
MC36B2AH1	17.5	26.5	16 3/8	16.5	3/8	7/8	2A
MC36B3XH1	17.5	26.5	16 3/8	16.5	3/8	7/8	None
MC36C2AH1	21	26.5	19 7/8	20	3/8	7/8	2A
MC36C3XH1	21	26.5	19 7/8	20	3/8	7/8	None
MC42B2CH1	17.5	32	16 3/8	16.5	3/8	7/8	2C
MC42B3XH1	17.5	32	16 3/8	16.5	3/8	7/8	None
MC42C2CH1	21	32	19 7/8	20	3/8	7/8	2C
MC42C3XH1	21	32	19 7/8	20	3/8	7/8	None
MC48C2CH1	21	32	19 7/8	20	3/8	7/8	2C
MC48C3XH1	21	32	19 7/8	20	3/8	7/8	None
MC48D2CH1	24.5	32	23 3/8	23.5	3/8	7/8	2C
MC48D3XH1	24.5	32	23 3/8	23.5	3/8	7/8	None
MC60D2CH1	24.5	32	23 3/8	23.5	3/8	7/8	2C
MC60D3XH1	24.5	32	23 3/8	23.5	3/8	7/8	None
MC61D2CH1	24.5	36	23 3/8	23.5	3/8	7/8	2C
MC61D3XH1	24.5	36	23 3/8	23.5	3/8	7/8	None

All MC coils include a factory installed horizontal drain pan.
(3X) = Models require field installed TXV.

* Refrigerant line sizes may require larger lines for extended line lengths. See York bulletin #690.01-AD1V for details.

Dimensions - FC Coils

Model	A	B	C	D	Refrigerant Line Size*		Factory Installed TXV (R22)
					Liquid	Vapor	
FC18A2AN1	14.5	18	13 3/8	13.5	3/8	3/4	2A
FC18A3XN1	14.5	18	13 3/8	13.5	3/8	3/4	None
FC18B2AN1	17.5	18	16 3/8	16.5	3/8	3/4	2A
FC18B3XN1	17.5	18	16 3/8	16.5	3/8	3/4	None
FC24A2AN1	14.5	22	13 3/8	13.5	3/8	3/4	2A
FC24A3XN1	14.5	22	13 3/8	13.5	3/8	3/4	None
FC24B2AN1	17.5	22	16 3/8	16.5	3/8	3/4	2A
FC24B3XN1	17.5	22	16 3/8	16.5	3/8	3/4	None
FC30A2AN1	14.5	22	13 3/8	13.5	3/8	3/4	2A
FC30A3XN1	14.5	22	13 3/8	13.5	3/8	3/4	None
FC30B2AN1	17.5	22	16 3/8	16.5	3/8	3/4	2A
FC30B3XN1	17.5	22	16 3/8	16.5	3/8	3/4	None
FC35B3XN1	17.5	22	16 3/8	16.5	3/8	3/4	None
FC35C3XN1	21	24.5	19 7/8	20	3/8	3/4	None
FC36A2AN1	14.5	24.5	13 3/8	13.5	3/8	7/8	2A
FC36A3XN1	14.5	24.5	13 3/8	13.5	3/8	7/8	None
FC36B2AN1	17.5	24.5	16 3/8	16.5	3/8	7/8	2A
FC36B3XN1	17.5	24.5	16 3/8	16.5	3/8	7/8	None
FC36C2AN1	21	24.5	19 7/8	20	3/8	7/8	2A
FC36C3XN1	21	24.5	19 7/8	20	3/8	7/8	None
FC42B2CN1	17.5	28	16 3/8	16.5	3/8	7/8	2C
FC42B3XN1	17.5	28	16 3/8	16.5	3/8	7/8	None
FC42C2CN1	21	28	19 7/8	20	3/8	7/8	2C
FC42C3XN1	21	28	19 7/8	20	3/8	7/8	None
FC48C2CN1	21	28	19 7/8	20	3/8	7/8	2C
FC48C3XN1	21	28	19 7/8	20	3/8	7/8	None
FC48D2CN1	24.5	28	23 3/8	23.5	3/8	7/8	2C
FC48D3XN1	24.5	28	23 3/8	23.5	3/8	7/8	None
FC60C2CN1	21	28	19 7/8	20	3/8	7/8	2C
FC60C3XN1	21	28	19 7/8	20	3/8	7/8	None
FC60D2CN1	24.5	28	23 3/8	23.5	3/8	7/8	2C
FC60D3XN1	24.5	28	23 3/8	23.5	3/8	7/8	None

FC coils are not available with a factory installed horizontal drain pan.
(3X) = Models require field installed TXV.

* Refrigerant line sizes may require larger lines for extended line lengths. See York bulletin #690.01-AD1V for details.

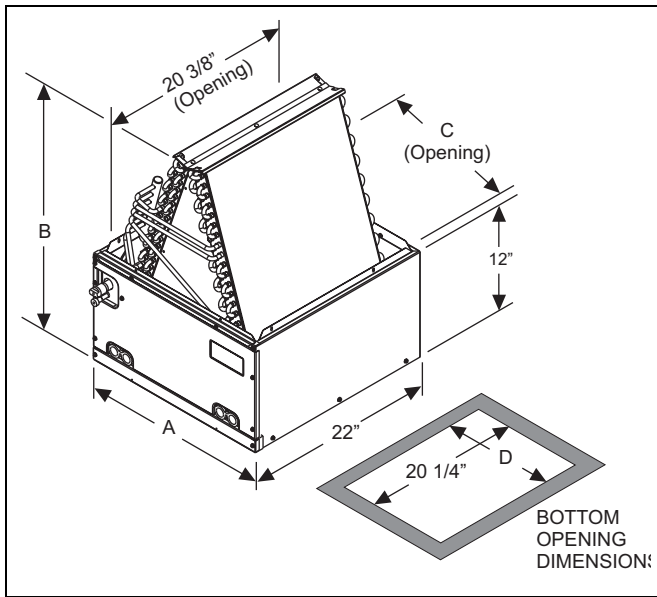

Coil - PC

Dimensions - PC Coils

Model	A	B	C	D	Refrigerant Line Size*		Factory Installed TXV (R22)
					Liquid	Vapor	
PC18A2AN1	14.5	17 3/4	13 3/8	13.5	3/8	3/4	2A
PC18A3XN1	14.5	17 3/4	13 3/8	13.5	3/8	3/4	None
PC18B2AN1	17.5	17	16 3/8	16.5	3/8	3/4	2A
PC18B3XN1	17.5	17	16 3/8	16.5	3/8	3/4	None
PC24A2AN1	14.5	21 7/8	13 3/8	13.5	3/8	3/4	2A
PC24A3XN1	14.5	21 7/8	13 3/8	13.5	3/8	3/4	None
PC24B2AN1	17.5	21 3/8	16 3/8	16.5	3/8	3/4	2A
PC24B3XN1	17.5	21 3/8	16 3/8	16.5	3/8	3/4	None
PC30A2AN1	14.5	21 7/8	13 3/8	13.5	3/8	3/4	2A
PC30A3XN1	14.5	21 7/8	13 3/8	13.5	3/8	3/4	None
PC30B2AN1	17.5	21 3/8	16 3/8	16.5	3/8	3/4	2A
PC30B3XN1	17.5	21 3/8	16 3/8	16.5	3/8	3/4	None
PC35B3XN1	17.5	18 7/8	16 3/8	16.5	3/8	3/4	None
PC35C3XN1	21	18 3/4	19 7/8	20	3/8	3/4	None
PC36A2AN1	14.5	23 7/8	13 3/8	13.5	3/8	7/8	2A
PC36A3XN1	14.5	23 7/8	13 3/8	13.5	3/8	7/8	None
PC36B2AN1	17.5	23 1/8	16 3/8	16.5	3/8	7/8	2A
PC36B3XN1	17.5	23 1/8	16 3/8	16.5	3/8	7/8	None
PC36C2AN1	21	22 7/8	19 7/8	20	3/8	7/8	2A
PC36C3XN1	21	22 7/8	19 7/8	20	3/8	7/8	None
PC42B2CN1	17.5	27 5/8	16 3/8	16.5	3/8	7/8	2C
PC42B3XN1	17.5	27 5/8	16 3/8	16.5	3/8	7/8	None
PC42C2CN1	21	27 1/8	19 7/8	20	3/8	7/8	2C
PC42C3XN1	21	27 1/8	19 7/8	20	3/8	7/8	None
PC48C2CN1	21	25 3/8	19 7/8	20	3/8	7/8	2C
PC48C3XN1	21	25 3/8	19 7/8	20	3/8	7/8	None
PC48D2CN1	24.5	24 5/8	23 3/8	23.5	3/8	7/8	2C
PC48D3XN1	24.5	24 5/8	23 3/8	23.5	3/8	7/8	None
PC60C2CN1	21	27 1/2	19 7/8	20	3/8	7/8	2C
PC60C3XN1	21	27 1/2	19 7/8	20	3/8	7/8	None
PC60D2CN1	24.5	26 7/8	23 3/8	23.5	3/8	7/8	2C
PC60D3XN1	24.5	26 7/8	23 3/8	23.5	3/8	7/8	None

PC coils are not available with a factory installed horizontal drain pan.
 (3X) = Models require field installed TXV.

* Refrigerant line sizes may require larger lines for extended line lengths. See York bulletin #690.01-AD1V for details.

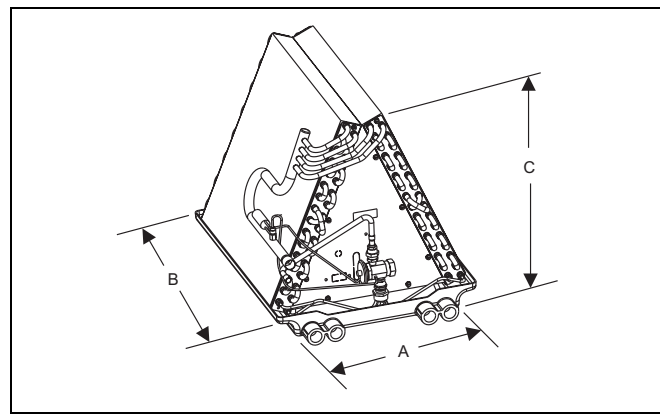

COIL - UC

Dimensions - UC Coils

Model	Dimensions — Inches			Refrigerant Connections	
	A	B	C	Line Size	
				Liquid	Vapor
UC18A3XN1	13	19.875	17	3/8	3/4
UC18A2AN1					
UC18B3XN1					
UC18B2AN1	16	16.5	20.5	7/8	
UC24A3XN1	13	21			
UC24A2AN1					
UC24B3XN1					
UC24B2AN1	16	20.5	21	7/8	
UC30A3XN1	13	21			
UC30A2AN1					
UC30B3XN1					
UC30B2AN1	16	20.5	23.5	7/8	
UC36A3XN1	13	22.5			
UC36A2AN1					
UC36B3XN1					
UC36B2AN1	16	22.5	22	7/8	
UC36C3XN1	19.5	26.5			
UC36C2AN1					
UC42B3XN1		16	25.5		
UC42B2CN1					
UC42C3XN1					
UC42C2CN1	19.5	23.5	23	7/8	
UC48C3XN1	19.5	25.5			
UC48C2CN1					
UC48D3XN1		23	23		
UC48D2CN1					
UC60C3XN1	19.5		25.5		
UC60C2CN1					
UC60D3XN1		23	25		
UC60D2CN1					

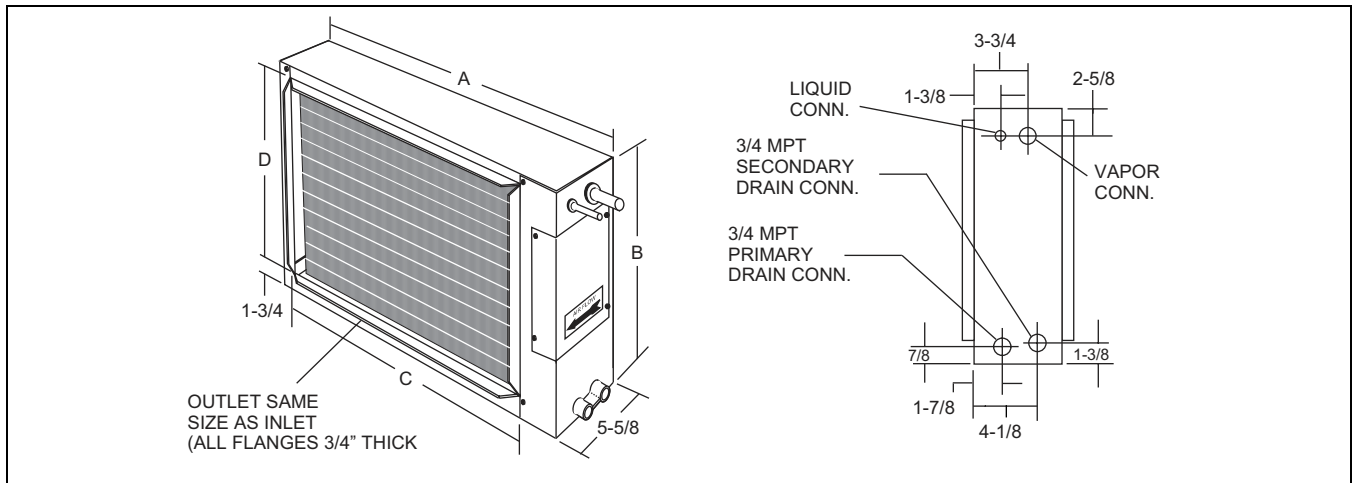

COIL - HD

Dimensions - HD Coils

Model	Dimensions — Inches				Refrigerant Connections	
	A	B	C	D	Line Size	
					Liquid	Vapor
HD24A**H1	28-3/4	24	23-3/4	21-5/8	3/8	3/4
HD36B**H1	28-3/4	28	23-3/4	25-5/8		7/8
HD48C**H1	34-3/4	28	29-3/4	25-5/8		
HD60D**H1	34-3/4	30	29-3/4	27-5/8		

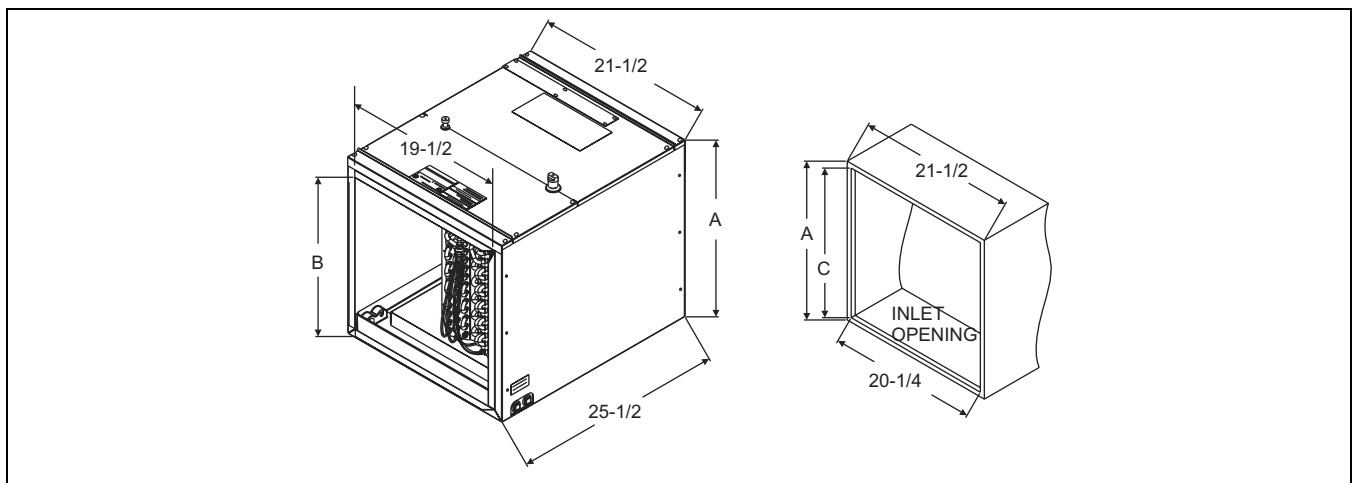

COIL - HC

Dimensions - HD Coils

Model	Dimensions — Inches			Refrigerant Connections	
	A	B	C	Line Size	
				Liquid	Vapor
HC18A**H1	15-5/16	13-1/4	14-3/16	3/8	3/4
HC30A**H1					7/8
HC36B**H1	17-9/16	15-1/2	16-7/16		
HC42C**H1	21-5/16	19-1/4	20-3/16		
HC60D**H1	25-5/16	23-1/4	24-3/16		

NOTES

NOTES

NOTES