

Volume

1

CEMENT TEST EQUIPMENT, INC. TULSA, OKLAHOMA, USA

Consistometer Instruction Manual

CEMENT TEST EQUIPMENT, INC.

Consistometer User's Manual

Revision C 12.24.10
© Cement Test Equipment, Inc.
5704 E. Admiral Blvd.
Tulsa, OK 74115
Phone 918.835.4454 • Fax 918.835.4475

Table of Contents

INTRODUCTION	I	
C H A P T E R 1		
TABLE OF CONTENTS	I	
INTRODUCTION	1	
WHAT IS A CONSISTOMETER USED FOR? ...	1	
INSTRUMENT DESCRIPTION	1	
INSTRUMENT SPECIFICATIONS	4	
INSTALLATION	5	
USING THE TOUCH SCREEN		
SOFTWARE	8	
WHAT IS A TOUCH SCREEN AND HOW DOES IT WORK?	8	
USING THE TOUCH SCREEN	8	
WHAT CAN YOU DO WITH THE TOUCH SCREEN SOFTWARE?	9	
THE MAIN MENU	9	
VIEW TEST	10	
INSTRUMENT SETUP	10	
TEST SETUP	12	
START TEST	15	
STOPPING A TEST	16	
SOFTWARE UPGRADES	16	
USING THE USB MEMORY STICK AND PRINTER	17	
A TOUR OF THE FRONT PANEL CONTROLS	18	
THE HYDRAULIC PRESSURE CONTROLS	18	
THE PNEUMATIC CONTROLS	19	
THE COOLING WATER CONTROLS	20	
OTHER ELECTRICAL AND ELECTRONIC CONTROLS	21	
OPERATION AND CALIBRATION	23	
A BRIEF EXAMPLE OF RUNNING THICKENING TIME TEST	23	
A BRIEF EXAMPLE OF STOPPING A THICKENING TIME TEST	24	
CALIBRATION	25	
PRESSURE CALIBRATION PROCEDURE	26	
CONSISTENCY CALIBRATION PROCEDURE	26	
MAINTENANCE, SERVICING, AND TROUBLESHOOTING	29	
MAINTENANCE	29	
PRESSURE VESSEL AND HYDRAULIC SYSTEM MAINTENANCE	29	
POTENTIOMETER MECHANISM (POT MECH) MAINTENANCE	31	
SLURRY CUP MAINTENANCE	31	
SERVICING	32	
CHANGING THE METAL O-RING	32	
CHANGING/CLEANING THE HIGH PRESSURE FILTER ELEMENT	33	
REPLACING THE LOW PRESSURE FILTER ELEMENT	33	
POTENTIOMETER MECHANISM RESISTOR REPLACEMENT	34	
POTENTIOMETER MECHANISM SPRING REPLACEMENT	35	
SERVICING THE INNER MAGNETIC DRIVE SHAFT	36	
SERVICING THE OUTER MAGNETIC DRIVE ROTATOR	36	
REMOVAL OF THE MAGNETIC DRIVE HOUSING	37	
HEATER REPLACEMENT	38	
TROUBLESHOOTING	40	

Introduction

This chapter contains general information about the consistometer and its uses as well as detailed specifications for the instrument.

What is a consistometer used for?

ICON KEY



Important
information



Potential Danger or
Safety Hazard



Operational Warning

Cements are a critical element in the drilling, completion, workover, and abandonment of wells. For each application, cement slurry is designed with specific properties and is given additives that provide predictable slurry density, volume, viscosity, compressive strength, fluid loss, gas migration, and thickening time. Slurry thickening time, or the time a slurry remains pumpable in a well, is one of the most critical properties in designing cement slurry. A predictable thickening time is desired, while maintaining the other specific properties of the cement slurry. The thickening time can be measured in a laboratory by testing a sample of the cement slurry in a pressurized consistometer. The elapsed time between initial application of pressure and temperature on the slurry sample and occurrence of a predetermined value of consistency (usually 100 Bearden Units, Bc) is the thickening time for the sample at the particular specification test schedule. The typical test schedules are listed in API Specification 10 on Oilwell Cements.

Instrument Description

The Model 40-600 Pressurized Consistometer is able to test cement slurries at temperatures up to 600°F/316°C and pressures as high as 40,000 psig/276 MPa. The Model 25-400 has operating limits of

400°F/204°C and 25,000 psig/172 MPa. The model 22-400 has operating limits of 400°F/204°C and 22,000 psig/151 MPa.

The consistometer Slurry Cup Assembly (part number 3-0030 or 2-0030) uses a rotating, cylindrical slurry cup and a stationary paddle assembly enclosed in a pressure vessel. Pressure is applied to the vessel using mineral oil and an air driven hydraulic pump. A tubular heater surrounding the slurry cup supplies heat to the pressure chamber. A centerline thermocouple is provided for determining the temperature of the cement slurry.

The slurry cup is rotated through the use of an electric motor and a magnetic drive unit. The rotational speed of the slurry cup is variable between 25 and 250 rpm to allow the user to study slurries at speeds other than the API prescribed speed of 150 rpm.

The consistency of the cement slurry is measured through a potentiometer mechanism commonly referred to as a 'pot mech'. The potentiometer is coupled with a torsion spring to resist the rotating force of the paddle. The rotational force is proportional to the consistency of the cement slurry and is measured through the potentiometer resistor as the spring deflects under load. The consistency is displayed on the plot generated by the data acquisition system. The consistency values are recorded in Bearded Units of consistency (Bc). Bearden units are defined in API Specification 10.

The consistometer is equipped with one or two devices for post-test cooling of the instrument. The first is an external-cooling coil attached to the pressure vessel. After completion of the test, cooling water may be circulated through this coil to cool the pressure vessel. The instrument is optionally equipped with an oil reservoir cooling coil as well.

Our temperature controller and data acquisition system are so easy to operate you won't even need a manual. We've thrown one in anyway, just in case.

The CTE pressurized consistometers are equipped with a state-of-the-art temperature controller and data acquisition system that provides unparalleled ease of use for the operator. The parameters of interest may be displayed in either English or SI units. Temperature control and data acquisition is programmed through the use of a touch screen monitor. A separate PC and keyboard/mouse are *not* required but may be connected through a network cable. A plot showing temperature and consistency (pressure is optional) may be plotted on any compatible ink jet printer. The plots may also be transferred automatically to a network or USB drive for use on a separate personal computer (PC).

A photograph of the CTE, Inc. dual consistometer is shown below.



Instrument Specifications

The specifications below apply to all CTE, Inc. full size pressurized consistometers.

ELECTRICAL

Input Voltage:	230 VAC ($\pm 10\%$)
Input Power:	5500W (single) 11000 W (dual)
Current:	24 A (single) 48 A (dual)
Input Frequency:	50-60 Hz

MECHANICAL

Height:	70 in. (175 cm)
Width (single):	33 in. (83 cm)
(dual):	51 in. (129 cm)
Depth:	29 in. (72 cm)
Weight (single):	1100 lb. (500 kg)
(dual):	2050 lb. (930 kg)

ENVIRONMENTAL

Operating Temperature:	(32 to 105°F) 0-40°C
Operating Humidity:	0-95% noncondensing

HEATER

Heater Power:	5,000 W
Heater Type:	Internal tubular with MgO insulation
Heater Control:	Solid state relay

DRIVE UNIT

Drive Motor:	1/8 Hp (93 W), 180 VDC
Drive Speed:	25-250 rpm (variable)

UTILITIES - WATER AND AIR

Compressed Air (maximum):	150 psig (10.2 bar)
(minimum):	80 psig (5.4 bar)
Cooling Water Pressure:	100 psig (6.8 bar) maximum
Utility Inlets:	¼ inch female NPT

Installation



Upon uncrating the instrument, verify that the instrument and any spare parts on the packing have been received and are undamaged. Notify CTE if anything is missing or damaged.

The instrument's center of gravity is located near the front of the instrument due to the weight of the pressure vessels. Be very careful when rolling or transporting the instrument that it does not tip over toward the front.

It is a good idea to leave room behind the instrument so that qualified personnel may have service access. If this is not possible, try to make the unit easy to disconnect and move for service.

Once the instrument has been moved to its desired location, air, water, and electrical connections can be made. The air inlet, water inlet, and water drain connections are each ¼ inch female NPT connections and are located on the lower right rear of the instrument. A number of ¼ inch male NPT to 8mm tube fittings are included for international locations. The air and water inlet connections may be made with either metal or plastic tubing. It is recommended that the water drain lines be made from metal, since this line may carry very hot water and steam from time to time.

Electrical connections are made using the twist lock receptacle on the rear of the instrument. A 50 A female plug (part number C-0524) is supplied with each dual consistometer and a 30 A female plug (part number C-0211) is included with each single consistometer. Please observe the following precautions when making the wiring connections.



- A qualified installer should do the wiring in accordance with local electrical codes.
- The instrument should be securely connected to a separate earth ground. The ground wire must be larger in diameter than the supply conductors. An 8-gauge minimum ground wire is recommended for a dual consistometer and a 10-gauge minimum ground wire is recommended for a single consistometer.
- An 8BC or larger fire extinguisher to fight electrical and oil fires should be placed within 50 feet of the consistometer.

Exposed metal surfaces on the seal shaft, sealing nut, and cylinder are coated to prevent rust. The coating should be removed with a hydrocarbon-based solvent before operation of the instrument.

Before operating the instrument, it is a good idea to check the bottom of the consistometer for loose screws or bolts that may have loosened and/or fallen out during shipment. This is particularly true for overseas shipments.

Certain components are supported during shipment with wooden blocks, foam padding, and plastic ties to prevent damage. Open the front doors and remove all the packing materials that would interfere with the operation of the instrument before powering the instrument. Some components such as touch screen LCD monitors (if applicable) and computer control modules are removed from the instrument prior to shipment and may be in a separate container to prevent damage. These devices must be reinstalled before operating the instrument.

Locate the box containing the touch screen monitors and remove them from their shipping containers. While standing at the rear of the instrument, align the four mounting holes in the black monitor housing with the four holes in the front panel. With the monitor screen facing the front of the instrument, secure the monitor to the front panel with the four screws provided. Connect the 15-pin video and USB cables from the monitor to the back of the control box. You must also connect the power cord from the monitor to an A/C outlet on the back of the instrument.

If the instrument is equipped with auxiliary stand alone temperature controllers, they must be removed from their shipping containers and installed into the sleeves in the front panel. Simply slide the controllers into the sleeves and snap them into place.

In order to protect the internal mechanisms of the pressure gauges, the needles are fixed in place with a screw and a small metal bracket. This bracket must be removed prior to using the instrument.

On 25-400 and 40-600 consistometers, the counterweight in each swivel arm has been locked in place prior to shipment to prevent the weight from damaging the swivel arm. Prior to removing the plug from the pressure vessel, loosen the bolt holding the counterweight in place until the counterweight is free to move.

The control box should be connected to the instrument by connecting the 5-pin power cord to the back of the instrument frame as well as the supplied USB cable. The instrument will not operate without this USB cable connected from the computer to the machine.

There are two power connectors on the back of the electrical box. An uninterruptible power supply (UPS) may be connected between these power connectors to maintain consistometer operation during short power outages or interruptions. If an UPS is not used, a jumper cord must be connected between these two connectors or the unit will not power up. An appropriate jumper cord was included with the consistometer accessories.

Some instruments, especially in overseas locations, have printer power connectors located on the rear on the electrical box. Check to see if yours does.

If a printer is included with the instrument, it may be connected to the rear of the consistometer. Connect the USB connector on the printer cable to any USB input on the control box. The printer must also be connected to an A/C power outlet. One is supplied on the back of the instrument for this. Refer to the printer documentation for power requirements. A USB flash drive may also be connected to the control box in lieu of a printer. Test data may be uploaded to the USB drive and then transferred to a PC for archival storage. Refer to Chapter 2, *Using the Touch Screen Software*, for more information on printer and USB drive. An optional keyboard may be connected to the control box at this time.

Before attempting to operate the instrument, it is recommended that the operators read the remainder of the manual and study the drawings that appear in the Drawings/Schematics section of this manual to become familiar with the consistometer operation.

Using the Touch Screen Software

What is a touch screen and how does it work?

Touch screens were created to provide users with an easy to use interface. This allows the user to input and view data without a keyboard or mouse. The touch surface is able to detect contact and send position information back to the processor. Using the touch screen has the same result of using a mouse to point and click. One mouse click is accomplished by one touch of the screen. A double-click is achieved with two quick touches. With this standard method of input, no special software is required to utilize the screen.

Using the Touch Screen

Most any object may be used on the touch-screens. Experimentation will quickly show which objects will activate the screen and which will not. It is important to note the touch surface does NOT use pressure to detect input. A light touch is all that is needed. In addition sharp instruments (such as pencils, pens, screwdrivers, etc.) should not be used as they may damage the touch surface. A pen-like touch stylus has been included in your accessories to use if desired.

What can you do with the touch screen software?

The purpose of the touch screen is to provide the user with a single interface to the instrument. Temperature control, motor control, instrument setup, and current test data are accessed through the touch screen. This eliminates the need to individually program controllers or other off-site PC software to begin running a test. Additionally, the touch screen allows the user to access current information at the instrument during a test. Each instrument is complete and requires no additional software or hardware to function.

The Main Menu



The main menu is starting point for the instrument. From here users may start new tests, set up test parameters, setup instrument parameters, or view an old test. Also located on the main menu is the current reading for temperature, consistency, and pressure (if so equipped).

As noted in the instructions on the screen, all the user need do is touch a button to begin.

VIEW TEST

Pressing this button opens the test viewer software and allows you to select any test file available.

INSTRUMENT SETUP

INSTRUMENT SETUP

This button takes the user to the Instrument Setup Screen. From this screen the user may calibrate temperature, consistency, gel strength (optional) and pressure (optional). Additionally, the user can **ARCHIVE** all tests on the consistometer to the USB memory stick or network location. This function will copy all tests in current C:/CTE data folder and paste them into the selected folder, networked drive, or USB. An **AUTO EXPORT** function allows the user to select a folder or network storage where any test will be automatically copied to after the test is stopped.

CALIBRATE TEMPERATURE – CALIBRATE PRESSURE

This button allows the user to select the calibration routines.

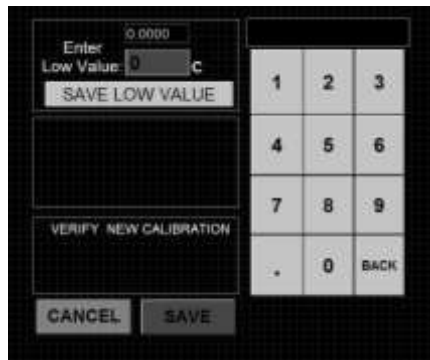

When this screen appears, connect a temperature calibrator to the thermocouple input on the instrument. Enter a lower-limit temperature value on the calibrator. Touch the **Enter Low Value** parameter box and then enter the correct temperature value for the Low Data Point using the touchpad at the right. The raw value is the signal read directly off the I/O hardware and it should change as the calibration signal changes.

When the low data point has been entered, press the **SAVE LOW VALUE** button. The user can now enter the high data point on the calibrator and then again on the touchscreen as before. The raw value should be different for the low and high data points or there will be a computation error.

After the high data point has been established, press the **SAVE HIGH VALUE** button. The user can now vary the calibration signal and see how the calibrated signal compares with that of the calibration device in the **VERIFY NEW CALIBRATION** box. If the signals compare favorably, press the Accept button to save the calibration. The calibration values will be stored in a configuration file and take effect upon exiting the **Instrument Setup** menu.

SAMPLE RATE

This menu allows the user to select a sampling rate for the Data Acquisition program. Rate is given in number of seconds between samples. To save data space and achieve acceptable test resolution, a sample rate of 30 or 60 seconds is recommended.

UNITS

These menus allow the user to select English or SI units for the Data Acquisition program. Additional units may be available as an option.

ARCHIVE DATA

This button allows the user to copy all the test files stored in the consistometer to an archive computer for permanent storage. The tests may be saved to the USB memory stick or to a local/network folder. Note that the program will ask for the storage location and the user may browse to any available drive or folder. Once the files are copied from the consistometer to the memory stick, the files remain on the consistometer and will still be accessible from the instrument. To permanently delete these files, the user must go to their stored location and delete them manually. The default location for CTE test files is C:/CTE/Tests. This folder also stores the actual test parameters so any test deleted cannot be run again without reprogramming **TEST SETUP**.

EDIT INSTRUMENT

This button should only be used when instructed to by CTE.

TEST SETUP

From this menu the user can enter or reset a temperature ramp and soak schedule. The user can also configure the hesitation squeeze and gel strength parameters on equipped instruments.

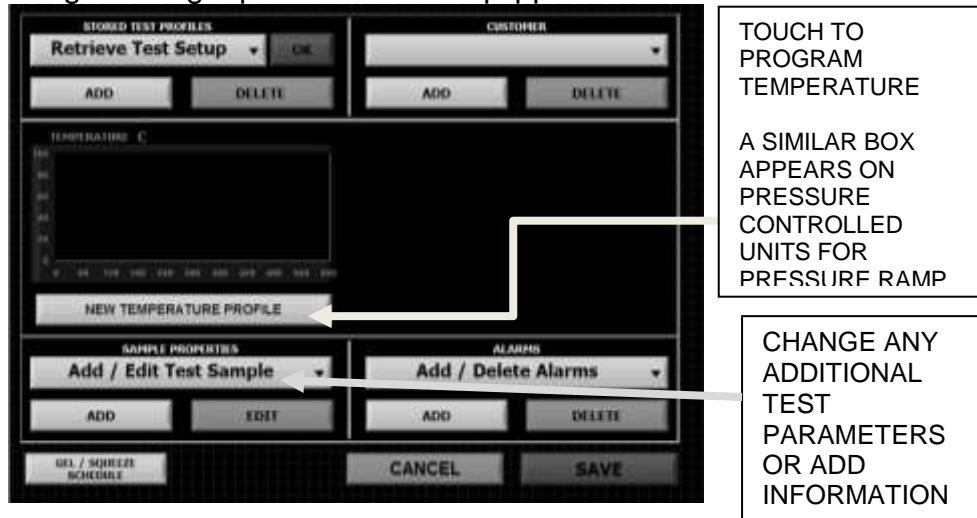

TEMPERATURE CONTROL (PRESSURE WHEN AVAILABLE)

The Program Temperature screen is shown below:

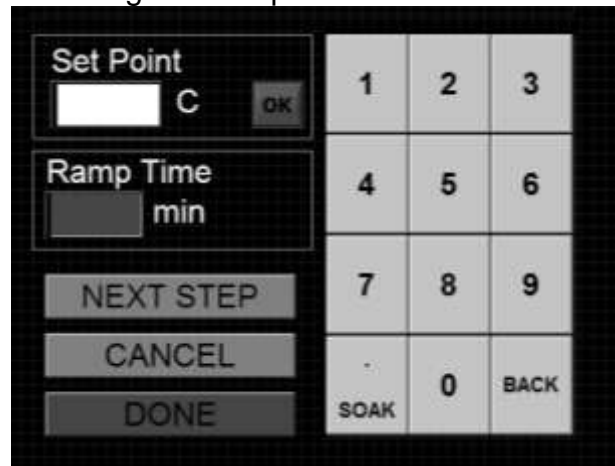

A TOUR OF THE FRONT PANEL CONTROLS

Enter desired set point values by touching the **SET POINT** parameter box and entering the values on the keypad. Time to set point is selected by touching the **TIME** parameter box and entering a time in minutes on the touch pad. The final segment should always be a **SOAK** segment where the temperature equals the final test temperature and the time equals **SOAK**. This guarantees the instrument will maintain final temperature for the remainder of a test. After a profile has been entered, press the **SAVE** button. At this point a graph of the desired temperature ramp is displayed for confirmation. Press: **ACCEPT** to save ramp or **CANCEL** to exit without saving.

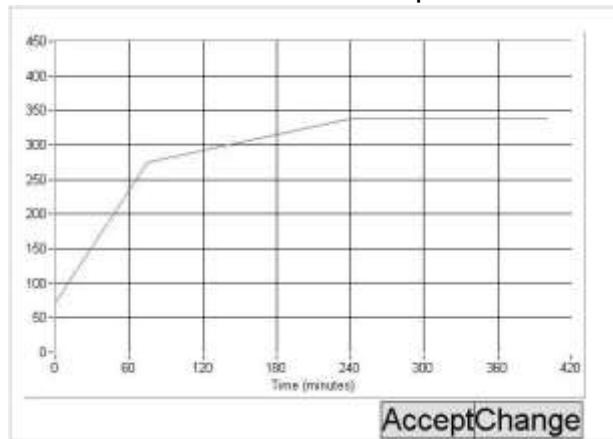

HESITATION SQUEEZE

On units equipped with the hesitation squeeze option it may be accessed using the button labeled **Hesitation Squeeze**. Pressing this button will bring up the following screen.



This allows a very random schedule to be programmed using user selected timing intervals.

A TOUR OF THE FRONT PANEL CONTROLS

Select Motor Speed = **Bc**, select the empty box under **Run Time** and enter the hesitation start time in minutes using the touch pad a right. The Start Time is the elapsed time from the beginning of the test to the first hesitation squeeze start.

Select **Next Ramp** to enter first stop. The screen will re-initialize and you can select **STOP** for motor speed and enter desired amount of time for STOP segment in **Run Time** box. Selecting **Next Ramp** again will allow you to enter run time after first STOP segment. If you wish to repeat the schedule for the remainder of the test simply select **AUTO REPEAT** after 3 segments have been entered (Bc-STOP-Bc). An infinite number of sequences can be input. Select **SAVE** to save or **Cancel** to exit without new schedule. A preview of the schedule will be shown for approval.

OPTIONAL PARAMETERS AND PROFILE SAVING

Many optional parameters can be saved in your test profile from the **Test Setup** screen. These include names for **Well, Cement, District,** etc... and can be input by simply touching on the ADD/EDIT boxes and entering data using the pop-up keypad. Additionally, repeat customers can be saved in the **Customer** menu by pressing **NEW** next to the **Customer** menu and inputting a customer name. The customer can then be selected from the drop-down **Customer** menu box. The entire profile of any test can be easily saved and recalled by selecting **SAVE PROFILE** after the profile has been completely configured. To recall a saved profile simply select it from the **SAVED PROFILES** drop-down menu and press **OK**. Customers and profiles can be deleted from memory by pressing the **RED DELETE BUTTON** next to either **Customer** or **Profiles**. Be sure to have the profile you would like to delete selected at the time you press the **DELETE** button. Test parameters can be deleted or changed by selecting the parameter and touching the **EDIT** button.

START TEST

Once your instrument is properly configured and a test has been entered in the **TEST SETUP** section. You may begin testing by selecting the **START TEST** button from the main menu.

LIVE TESTING SCREEN

Once a test has begun, a real-time display of current values will be presented. The user may view a live chart at any time by pressing the **LIVE CHART** tab button located at the top of the screen. Printing can be done at any time by selecting the **ADVANCED CHART & PRINTING OPTIONS** button (Please note that a printer must be connected to the instrument before trying to print.). This button will also enable the user to view detailed test information and streaming numerical data. The user can also create custom header and footer segments of the printed plot. Pressing the **EXIT** button returns the user to the **RUN TIME MENU** shown below.

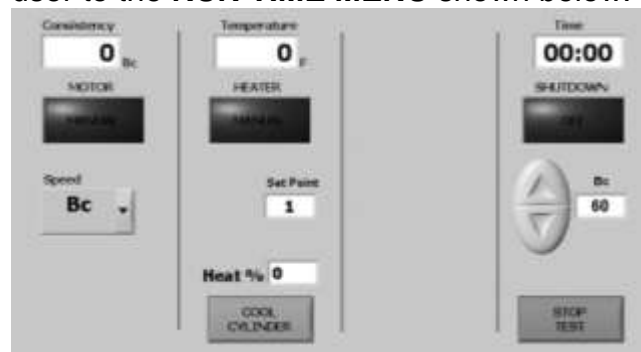

(some options not shown)



Temperature control may be toggled between **AUTO** and **MANUAL**. **AUTO** is recommended. Note that establishing a set point significantly different from the current temperature may cause large overshoots in temperature set point. If manual temperature control is required, it is recommended that it be increased slowly in 2-5 degree increments.

The instrument is equipped with an automatic consistency shutdown alarm. Use the up/down arrows to select the consistency value at which the alarm should occur. If the Auto Shutdown feature is ON, the instrument will automatically stop the test when the indicated alarm value is reached. In addition to stopping the test, automatic

shutdown will also turn the heater and motor off and the cooling water on. Note that the Auto Shutdown Alarm is in addition to the alarm values entered in **TEST SETUP** that are printed with each plot.

STOPPING A TEST

To stop the current test, the user must press the STOP TEST button on the **RUN-TIME MENU** screen. Once the test has been stopped, no further data will be logged and no further temperature or pressure control will be provided. The software will save the current test in a file on the instrument's local hard disk. The default location is C:/CTE/Tests. If auto-shutdown is enabled, the test will be stopped when the Consistency Alarm value has been reached. This action has the same effect as the user pressing the STOP TEST button; however it also turns the motor and heater off and the cooling water on. Note that there is a 5-10 second delay from the time a consistency alarm is triggered until automatic shutdown occurs. This is to prevent noise or spikes in the consistency signal from triggering automatic shutdown prematurely.

Software Upgrades

From time to time, CTE makes software upgrades available that provide increased functionality or problem fixes. Generally, the only file that needs to be upgraded is *CementLab.exe*. It is located in the c:\Program Files\CementTestEquipment folder. If it is necessary to install an updated *CementLab.exe* file, it may be copied from the USB memory stick. It may also be copied over a network if the instrument is connected to one. To copy the file from a memory stick, put the new file on the memory stick, rename the old *CementLab.exe* file to "Old.exe" and copy the new file into the proper folder using Windows Explorer, which is accessible from the start menu or **My Computer** icon. The memory stick will generally be the D: drive. Should the new *CementLab.exe* program not work properly, simply delete it and restore *Old.exe* to the original.

Using the USB Memory Stick and Printer

The instrument is equipped with a Universal Serial Bus (USB) port that allows the use of a USB memory stick for mobile storage. The memory stick is a flash disk that can be connected to the USB port on the instrument control box and used as an external disk drive. Simply insert the memory stick into the USB port and the memory stick will become the *D:* drive. Software upgrades may be installed using the memory stick and tests may be archived to the memory stick and transferred to a PC for permanent storage.

A Tour of the Front Panel Controls

Chapter 3 will discuss in detail each front panel control found on both dual and single consistometers.

All the functions of the consistometer are controlled from the front panel. It is very important for the user to have a thorough understanding of each control and its effect on the operation of the consistometer.

The front panel controls can be roughly divided into four different sections: the hydraulic pressure controls, the pneumatic controls, the cooling water controls, and the electrical/electronic controls. This chapter will discuss each section in detail.

It may be convenient to refer to the piping drawings in Chapter 6 when studying this section.

The Hydraulic Pressure Controls

This section consists of the following controls: the **PRESSURE** gauge, the **PRESSURE RELEASE** valve, and the **FILL/DRAIN** switch. Components that make up this section are used to control the flow of oil used to pressurize the cylinder and to display the cylinder pressure.

The pressure gauge displays pressure in both English and SI units.

The **PRESSURE** gauge is used to display the pressure inside the pressure vessel. The part number for the pressure gauge is C-0465.

The **PRESSURE RELEASE** valve is used to release pressure from the pressurized cylinder. The **PRESSURE RELEASE** valve must also be fully opened to remove oil from the cylinder. If it is necessary to fill only one pressure vessel of a dual consistometer, the

PRESSURE RELEASE valve on the unfilled side must be closed or oil may back up into the cylinder through the oil return lines. The part number for the **PRESSURE RELEASE** valve is C-0005-1.

The **FILL/DRAIN** switch is used to control the flow of oil into the pressure vessel. When the switch is set to **FILL** and there is air pressure on the instrument, oil will begin to flow into the cylinder. Ensure that the lid is closed and thermocouple fitting is loose to allow air to escape while filling.

When the switch is set to **DRAIN**, the **PRESSURE RELEASE** valve is open, and air is exhausted from the instrument, the cylinder will be emptied of oil. Under **DRAIN** conditions, the cylinder must be closed. When the selector is in the **OFF** position, the instrument is idle and cannot be run.

Note for DUAL Consistometer: If only one cylinder is to be drained of oil, the **AIR EXHAUST** must be active. During the draining process the other side of the instrument cannot pump until **AIR SUPPLY** is turned back on after fully draining the non-active cell.



The Pneumatic Controls

The pneumatic section consists of the **AIR PRESSURE** gauge, the air pressure **REGULATOR**, the **PUMP AIR PRESSURE** gauge, and the **AIR SUPPLY / AIR EXHAUST** valve (DUAL consistometer only). The components in this section are used to fill and drain oil from the pressure vessel and to power the air driven hydraulic pump that applies pressure to the sample.

The pressure gauge displays pressure in both English and SI units.

The **AIR PRESSURE** gauge indicates how much air pressure is being supplied to the instrument. Air at the pressure indicated on the gauge is supplied to the oil reservoir to force oil out through the dip tube(s) and into the pump inlet. The part number for the **AIR PRESSURE** gauge is C-0364. If there is no pressure indicated on this gauge, the pump will not operate.

If the PUMP AIR PRESSURE drops off significantly when the pump is operating, an air line may be blocked or the compressor may be insufficient to deliver the volume of air required.

The air pressure **REGULATOR** is used to control the air pressure to the air driven hydraulic pump. Higher hydraulic pressures require higher air pressures. To adjust the pressure of the air supplied to the pump, pull the knob on the regulator out to unlock it. Turn the regulator knob clockwise to increase the pressure and counterclockwise to decrease the pressure. When the adjustment is finished, push the knob in to lock it in place if desired. The part number of this regulator is C-0021.

The **PUMP AIR PRESSURE** gauge shows the pressure of the air delivered to the pump. The pressure may be changed by adjusting the air pressure **REGULATOR** as described above. The part number of this gauge is C-0364.

DUAL UNITS: AIR SUPPLY / AIR EXHAUST switch. This switch accompanies the **FILL/DRAIN**. Any time you wish to **FILL** a cylinder or **RUN** a test, the **AIR SUPPLY** must be **ON**. Any time you wish to drain a cylinder, you must select **AIR EXHAUST** to relieve air pressure from the oil reservoir. If only one cylinder is to be drained of oil, the **AIR EXHAUST** must still be active. During the draining process the other side of the instrument cannot activate the pump until **AIR SUPPLY** is turned back on. Do this immediately after fully draining the non-active cell.

The Cooling Water Controls

The cooling water controls are used to cool the cylinder and oil reservoir at the completion of a test. The CTE pressurized consistometers are optionally equipped with an industry first: internal cooling coils in the oil reservoir for quick cooling of the hydraulic oil and faster turnaround between tests. The cooling water controls consist of a **COOLING WATER** switch and a **RESERVOIR COOLING** switch.

The **COOLING WATER** switch allows water to flow through the cooling jacket surrounding the pressure vessel. This valve should be turned on at the completion of a test to cool the pressure vessel. Alternatively, software can be used to cool the cylinder automatically.

The **RESERVOIR COOLING** switch allows water to flow through the internal cooling coils in the oil reservoir to cool the hydraulic oil. This valve may be opened at the completion of a test to or it may be opened during a test if the oil in the reservoir becomes too hot or if it is desired to keep the oil cool to reduce turnaround time for the next test.

Other Electrical and Electronic Controls

Additional primary electrical/electronic controls may include the **POWER**, **HEATER**, **MOTOR**, and **TIMER** switches, the pump controls, and motor speed adjustments. The primary display is the touch screen. These controls are discussed in detail below.

The switch labeled **POWER** controls electrical power to the entire instrument. Nothing else is operable if this switch is not on. If available, switches labeled **HEATER** and **MOTOR** can be used to disable power to the heater and motor. Under normal conditions, these switches may be left in the **ON** position. Leaving the **HEATER** switch **ON** will not heat the instrument unless a test is running. If equipped with an external timer, a **TIMER** switch will enable the elapsed timer. The part number for the **POWER**, **HEATER**, and **MOTOR** switches is C-0075 and the part number for the **TIMER** switch is C-0076 and the timer itself is C-0200.

CTE is the first company to offer variable speed as a standard feature on all its' pressurized consistometers.

An optional **MOTOR SPEED** tachometer displays the rotational speed of the slurry cup when the motor is running. The **SPEED CONTROL** potentiometer is used to vary the speed between approximately 25 and 250 rpm. The part number for the tachometer is C-0388 and the part number for the potentiometer is C-0397.

The touch screen is used to control temperature and pressure or other parameters when available. The screen will also display a plot of consistency and temperature, pressure, etc... as a function of elapsed time. More in-depth explanation of the touch screen capabilities may be found in Chapter 2.

A part number 3-0036 thermocouple is plugged into the **THERMOCOUPLE** connector so the centerline temperature of the

A TOUR OF THE FRONT PANEL CONTROLS

slurry cup may be monitored. The **CALIBRATOR** socket accepts any standard consistometer calibrator. The part number for the **THERMOCOUPLE** connector is C-0167 and the **CALIBRATOR** connector is C-0222.

The pump switch may be one of two varieties, depending on whether the automatic pressure control option is installed. If automatic pressure control is not installed, the instrument will be equipped with a C-0076 switch that is used to turn the pump on and off. If the pressure control option is installed, the unit will be equipped with a three-position switch, labeled **ON**, **OFF**, and **AUTO**. When the switch is in the **OFF** position, the pump will not run. When the switch is in the **ON** position, the pump will run until turned to the **OFF** position. When the switch is in the **AUTO** position, the pump will be turned on and off by the pressure control software. The part number for the three position switch is C-0302.

This completes our tour of the front panel components. The operation of these components will be discussed in greater detail along with examples in Chapter 4, *Operation and Calibration*.

Operation and Calibration

Chapter 4 will discuss in detail the steps required to run a thickening time test and calibrate the instrument. Examples will be provided when necessary.

A Brief Example of Running Thickening Time Test

The steps listed below are for experienced users who are familiar with consistometer operation.

1. Close the **PRESSURE RELEASE** valve if supplied.
2. Turn the **POWER** switch to the ON position.
3. Turn the **MOTOR** and **HEATER** switches to the ON position if available. *CAUTION:* On consistometers with serial number below 207 and “Small Footprint” units, the **HEATER** switch should remain OFF until testing begins.
4. Program temperature (and pressure if unit is so equipped) ramp and soak on the touch screen.
5. Mix the slurry and fill the slurry cup.
6. Place the slurry cup and the potentiometer mechanism (pot mech) into the pressure vessel and engage the slurry cup to the cup table. The motor may be turned on now or at any time using the software selector switch.
7. Close the lid on the pressure vessel. Insert the thermocouple, but do not tighten thermocouple fitting.

A light coating of grease on the threads is important to prevent cement from filling the threads.

It is not necessary to pound the lid closed with a sledgehammer.

8. Turn **FILL/DRAIN** switch to **FILL** and fill the pressure vessel with oil. On a dual consistometer, the **AIT SUPPLY** switch must also be ON. When oil begins to run out the top, tighten the thermocouple.
9. Verify the instrument is reading consistency and start the test using the touch screen.
10. Adjust the pressure during the test as desired. On units without automatic pressure control, releasing pressure may be necessary to prevent an over-pressure condition while heating.

A Brief Example of Stopping a Thickening Time Test

The steps listed below are for experienced users who are familiar with consistometer operation.

1. Stop the test using the touch screen.
2. Turn **COOLING ON**
3. When temperature has cooled below 212°F/100°C, open the **PRESSURE RELEASE** valve and set **AIR EXHAUST** on DUAL units.
4. When the pressure is at zero, select **DRAIN**. This will blow the oil from the pressure vessel into the oil reservoir. You will hear AIR escaping from the rear of the instrument once the cylinder is empty of oil. At this point you must turn the **FILL/DRAIN** switch to **OFF**.
5. Open the **RESERVOIR COOLING** valve to cool the oil in the reservoir if equipped and desired.

All CTE slurry cups are tapered, with the large end at the top. This makes it easier to press the cement plug out of the slurry cup.

6. When the cylinder is cool enough, remove the slurry from the slurry cup before it sets and becomes too hard. Press the cement plug out from bottom to top.

Calibration

If the instrument is within tolerance after several calibration checks, extend the calibration interval. If it is out of tolerance, shorten the interval.

The potentiometer mechanism, thermocouple, and pressure transducer (optional) should be recalibrated on a regular basis. It is recommended that the thermocouple and pressure transducer (if so equipped) be calibrated at least annually and anytime new thermocouples or pressure transducers are installed. The potentiometer mechanism (pot mech) should be recalibrated whenever the spring, contact arm, or resistor is adjusted or replaced. Higher operating temperatures generally require more frequent recalibration.

Temperature Calibration Procedure

Temperature may be calibrated using the Temperature Calibrator (CTE part # C-0373).

1. With Instrument ON and *CementLab* running, select **INSTRUMENT SETUP – CALIBRATE TEMPERATURE**.
2. Disconnect thermocouple from inside instrument. The plug is located behind the heater. Connect the Temperature calibrator to this plug.
3. Enter a value of 125C or 275F in the calibrator.
4. Verify that the **RAW VALUE** on the touchscreen is changing as you enter a new number into the calibrator. This time enter 25C or 60F into the calibrator.
5. Enter the same temperature value into the **LOW VALUE** box in *CementLab*.
6. Select **SAVE LOW VALUE**.
7. On the calibrator, input 220C or 400F.
8. Enter the same number into the **HIGH VALUE** box in *CementLab*.

9. Select **SAVE HIGH VALUE**.
10. On the calibrator, enter 100C or 200F.
11. Verify the calibration is reading the same value on the touchscreen.
12. Select **SAVE or DONE** and Exit Calibration screen.



Pressure Calibration Procedure

Pressure may be calibrated using a Digital Pressure Calibrator. Simply remove pressure vessel and attach calibrator to the thermocouple port on top of the cylinder. If equipped with software pressure display, start the **CALIBRATE PRESSURE** routine as was done for Temperature. Ensure no pressure is on the pressure vessel and enter zero as the LOW VALUE, **SAVE LOW VALUE**.

FILL the cylinder with oil and then verify pressure gauge readings at different pressures. If optional software pressure unit to maximum typical operating pressure and input the digital calibrator gauge reading into the HIGH VALUE of the software calibration screen. **Be sure you are in the correct units and SAVE HIGHVALUE**. Next, release some pressure and verify the CALIBRATED VALUE is correct. SAVE and depressurize/drain instrument.

Consistency Calibration Procedure

The consistency should be calibrated by using the consistency calibrator assembly.

The potentiometer mechanism and the digital meter, which indicates consistency, should be calibrated by using the potentiometer mechanism calibrator. This device applies a known torque to the potentiometer mechanism spring, allowing the readout to be observed on the **CALIBRATE CONSISTENCY** screen (In TEST SETUP of software program). Calibration of the potentiometer mechanism is described in the example below.

1. Set the calibrator near the front edge of the consistometer.
2. Install the potentiometer mechanism to be calibrated on the holder. Insert the wedge into the open slot nearest the potentiometer ground spring.
3. Wind the cord around the potentiometer mechanism frame and over the pulley. Place the hanger weight hook in the loop on the end of the cord.
4. Install the alligator clips to the potentiometer mechanism springs matching the wire colors to the contact pin wire colors.
5. Insert the calibrator plug into the **CALIBRATOR** socket on the front panel of the instrument.
6. From the software IDLE screen, select **INSTRUMENT SETUP** and then select **CALIBRATE – CONSISTENCY**.
7. The weight of the hook on the string is 50g. This is an equivalent of 9 Bc. On the touchscreen in the box labeled **LOW DATA POINT** input 9 on the touchpad. Select **SAVE LOW VALUE**.
8. Place 400g of weights on the weight hanger. This is the equivalent of 100 Bearden Units of Consistency (Bc). On the touchscreen in the box labeled **HIGH DATA POINT** input 100 on the touchpad. Select **SAVE HIGH VALUE**.
9. The touch screen should indicate 100Bc in the **CALIBRATED VALUE** display.
10. Remove some weight and check the **CALIBRATED VALUE**. If the values are correct, calibration is complete. If the values are incorrect, repeat steps making adjustments to Potentiometer Mechanism as required. Refer to table 4.1 for weight to Bc conversions for your pot-mech.

By applying additional weights between 0 and 400g and plotting consistency display as a function of applied weight, the linearity of the potentiometer mechanism may be assessed.

Table 4.1 Consistency as a function of Weight vs. Torque*

WEIGHT (g)	CONSISTENCY (Bc)
0	-4
50	9
100	22
150	35
200	48
250	61
300	74
350	87
400	100

* Based on the equation from API Spec 10, Section 8.2T = 78.2 + 20.02 Bc
T = Torque, g.cm
Bc = Bearden units of slurry consistency

Maintenance, Servicing, and Troubleshooting

This chapter contains information about the necessary periodic maintenance of the instrument as well as common service and troubleshooting guidelines.

Maintenance

Consistometers can be relatively reliable and trouble free - provided they are serviced and maintained properly. Instruments that are neglected and receive infrequent service or are subject to abuse are certain to cause trouble.

Pressure Vessel and Hydraulic System Maintenance

The metal o-ring, the pressure vessel o-ring seat, and the bottom of the seal shaft are the keys to reliable pressure sealing. If these components are free from debris and scratches/dents, reliable sealing will be easily achieved. Refer to drawings 3-0020 and 3-0009 in Chapter 6 for information on the cylinder assembly and the hydraulic system.

1. Inspect the pressure vessel's metal o-ring (part number C-0061) and the seat below it after each test and wipe it free of cement particles and other debris. Do not use sharp objects, such as screwdrivers, when removing the metal o-ring as it will likely bend or scratch the o-ring, ruining it. Should the seat below the o-ring or the seal shaft become pitted or scratched from cement particles

that have migrated into the seal, lapping of the seat and seal shaft may be required.

2. The cylinder plug threads have been coated with a friction reducing PTFE coating by the factory to help prevent thread seizing and galling. However, it is still recommended to apply a molybdenum disulfide anti-seize compound to the threads periodically.
3. The high-pressure filter is located in the 3/8-inch stainless steel pressure lines, between the pressure vessel and the pressure release valve. This filter protects the pressure release valve, air operated valve (if equipped), and capillary tube (if equipped) from cement particle damage and/or blockage. It also prevents cement particles from being carried into the oil reservoir. This filter must be disassembled and the filter element cleaned or replaced periodically.
4. The mineral oil in the reservoir should be drained and replaced when it becomes dirty. The low-pressure oil filter element (part number C-0102) should also be replaced periodically. These filters are located in a blue housing. The oil reservoir is equipped with drain valve on the bottom and a filling plug at the top. To thoroughly clean the reservoir, the entire unit may be taken out of the instrument and the bottom removed. Mineral oil may be conveniently added by pouring oil into the pressure cylinder and transferring it to the oil reservoir. The mineral oil supplied with the instrument has an open cup flash point of approximately 188°C/370° F.
5. The magnetic drive should be flushed with clean solvent periodically and whenever cement spills into the cylinder or particles contaminate the drive. If cement enters the magnetic drive, it will cause the bearings to wear quickly. If the worn bearings are not replaced, it may cause the inner magnetic drive shaft to wear out prematurely. Worn bearings may also cause excessive slurry cup run-out.
6. The filter, regulator, lubricator unit (FRL), supplies lubrication and filtration for the pump air. This unit is attached to the pump air inlet, after the solenoid valve. The filter unit is upstream of the regulator unit and it should be checked periodically and the bowl cleaned if filled with water or debris. The lubricator is located just downstream of the filter. A quality grade of lubricating oil, approximately SAE 10, should be added routinely to the plastic reservoir, otherwise it will run dry and leave the air side of the

If the transfer of the oil from the pressure vessel to the reservoir is slow, the filter probably needs to be cleaned or replaced.

pump un-lubricated, perhaps leading to premature failure of the pump.

Do not pour the lubricating oil into the filter bowl by mistake.

Potentiometer Mechanism (Pot Mech) Maintenance

Refer to drawing 2-0050 in Chapter 6 for an exploded view of a potentiometer mechanism assembly.

1. Check upper and lower bearings for smooth, friction free operation. If bearing operation is not smooth, clean or replace the bearings. If the bearings do not operate smoothly, it may cause thickening times to increase.
2. Check for broken wires in the potentiometer resistor. The resistance should measure between 80 and 100 Ω . The surface of the resistor that is in contact with the wiper may be burnished with a smooth, round rod (such as a screwdriver blade) to reduce noise in the consistency signal if necessary.
3. Periodically check that the wiper is making contact with the potentiometer resistor throughout it's entire length of travel.

Slurry Cup Maintenance

Refer to drawing 3-0030 in Chapter 6 for a section view of a slurry cup.

1. Check the slurry cup after every test to be certain the threads are not contaminated with cement. Lubricate the threads with grease prior to the start of every test.
2. It is recommended that hardened cement slugs be pressed out, rather than pounded out with a hammer. Pressing tends to cause less damage. When pressing the slug out, be careful not to damage the paddle shaft point or the paddle itself. If the slug is not pressed out straight, it may cause the cup sleeve to become oval and prevent the threaded closures from threading into the sleeve.

3. Periodically disassembly the diaphragm hub and clean any cement from the Teflon o-rings. Replace the o-rings if they are badly worn.
4. Check the rubber diaphragm for signs of brittleness or cracking. Replace if necessary.
5. Check the point on the bottom of the paddle shaft. Replace it if it is worn to the point that the paddle rubs on the bottom of the slurry cup. Check to see that the paddle shaft is not excessively worn where the shaft extends through the diaphragm hub. Replace if wear is excessive.
6. Check the slurry cup seal plug for wear. Replace it if it is worn to the point that the paddle rubs on the bottom of the slurry cup.

Servicing

This section provides information on servicing the components most commonly in need of repair.

Changing the metal o-ring

1. Refer to drawing 3-0020 Cylinder Assembly in Chapter 6 when changing this o-ring. Pry the old o-ring out using a plastic or soft metal tool so as not to damage the sealing surfaces.
2. Coat the new o-ring (part number C-0061) with a light coating of grease.
3. Press the new o-ring into the seal groove using your fingers. Do not bend or scratch the new o-ring.
4. Place the plug in the pressure vessel and thread in place until the seal shaft contacts the new o-ring.
5. Using a rubber mallet or dead blow hammer and light blows, begin to close the plug and compress the o-ring. After three hits with the hammer, unscrew the plug part way. Repeat this process until the scribe lines on the plug and cylinder are lined up. Installation is now complete.

6. Realignment of the witness marks on the plug and cylinder is recommended each time the seats are lapped or if pressure leakage persists. In time, plug and cylinder threads wear and heat-induced flexing of the plug and cylinder require witness mark realignment because the marks no longer represent the actual seating of the seal shaft.

Changing/cleaning the high pressure filter element

Refer to drawing 2-0071 Filter Assembly when servicing filter.

1. Disconnect the 3/8-inch high-pressure connections and remove the 2-0071 Filter Assembly.
2. Secure the 2-0072 Filter Housing in a vice and remove the 2-0074 Seat Retainer.
3. Compressed air may be forced through the 2-0076 Filter Element to remove the debris attached to the filter. The 2-0076 Filter Element may also be unscrewed from the 2-0075 Filter Nipple and cleaned with solvent or a weak acid solution.
4. Thread the filter onto the filter nipple. Install the filter element and 2-0073 Filter Seat into the housing and secure tightly with the seat retainer.
5. Install the filter back in the instrument. If transferring the oil from the pressure vessel to the reservoir is still slow, replace the 2-0076 Filter Element.

To minimize the mess, place a bucket or cup under the filter housing to catch any oil that might spill.

Replacing the low pressure filter element

1. Make certain all valves are closed.
2. Open the AIR EXHAUST valve.
3. Locate the blue, low-pressure oil filter housing.

4. Remove the nut on the top of the filter housing. The filter bowl and C-0102 filter element will come off.
5. Replace the filter element with a new element.
6. Inspect the C-0101 gasket and replace if necessary.
7. Replace the bowl and filter element and install the nut. It may appear that the filter element is too long, but the element will be compressed as the nut is tightened which separates the filtered oil from the unfiltered oil.
8. Check for leaks.

Potentiometer Mechanism Resistor Replacement

Refer to drawing 2-0050 when replacing the 2-0062 Resistor.

1. Remove 2-0064 Shaft Bearing Retainer and 2-0077 Potentiometer Slider.
2. Remove old resistor from 2-0052 Mounting Frame, being careful not to damage slot.
3. Position new resistor over the slot in the mounting frame with the straight side down. The 2-0051 Connecting Strip must be installed under the resistor in the groove in the mounting frame. The length of resistor extending past the connecting strip should be approximately even on both ends.
4. Seat the resistor securely in the slot in the mounting frame. Use care to avoid damage to the resistor. The top surface of resistor must be level with the top of the mounting frame.
5. Use a smooth, round rod (such as the round shank of a screwdriver) to rub top surface of resistor, burnishing resistance wire lightly so potentiometer slider will slide smoothly with minimal noise.

6. Rotate potentiometer slider by hand. Assure that slider makes contact with the resistor during its entire range of motion. If necessary, adjust slider by bending it up or down.
7. Replace shaft bearing retainer and check the potentiometer mechanism with a calibrating device.

Potentiometer Mechanism

Spring Replacement

Refer to drawing 2-0050 when replacing the 2-0060 Spring.

1. Remove 2-0064 Shaft Bearing Retainer and 2-0077 Potentiometer Slider.
2. Remove old spring.
3. Install new spring.
4. Replace potentiometer slider.
5. Loosen the three spring adjuster clamp screws on underside of the frame, but do not remove the screws.
6. Rotate the 2-0053 Spring Adjuster until the potentiometer slider lines up with the front contact strip. Tighten adjuster clamp screws.
7. Rotate potentiometer slider by hand. Assure that slider makes contact with the resistor during its entire range of motion. If necessary, adjust slider by bending it up or down.
8. Replace shaft bearing retainer and check the potentiometer mechanism with a calibrating device.

The spring should wind tighter when the slider is moved in the counter-clockwise direction.

Servicing the Inner Magnetic Drive Shaft

Refer to drawing 3-0063 Magnetic Drive Assembly in Chapter 6 for servicing all magnetic drive components.



It is sometimes necessary to remove the 3-0065 Plug Assembly from the bottom of the 3-0062 Magnetic Drive Housing. The oil in the magnetic drive can create a vacuum that makes removal of the inner shaft difficult, especially if the housing is contaminated with cement.

1. Pull the 3-0070 Inner Magnet Shaft Assembly out through the top of the pressure vessel.

CAUTION: The inner shaft is composed of extremely powerful magnets. If these magnets are allowed to get too close to steel objects the magnetic force may cause injury or damage to the shaft. Also keep the shaft away from metal filings, as they will adhere to the shaft and cause premature wear.

2. Unscrew the cup table from the magnet shaft assembly.
3. Press the C-0108 Roll Pin out of the 3-0071 Thrust Ring and remove the thrust ring. Take care not to bend the shaft. Replace the thrust ring if badly worn.
4. The upper 3-0072 Bronze Bearing may now be removed. Replace if badly worn.
5. Remove the C-0130 Snap Ring. Replace is corroded or damaged. The 3-0073 Carbon Bearing or the 3-0073-1 Bronze Bearing may now be removed. Replace if badly worn.
6. Remove the hex head screw and 3-0074-6 Washer from the other end of the shaft to remove the second 3-0073 or 3-0073-1 Bearing. Replace if badly worn.
7. Assemble in reverse order of disassembly.

Servicing the Outer Magnetic Drive Rotator

Refer to drawing 3-0063 Magnetic Drive Assembly in Chapter 6 for servicing all magnetic drive components.



CAUTION: Make certain that the power to the instrument is disconnected before servicing the magnetic drive rotator. The rotator is very close to the heater terminals and severe shock or electrocution could occur if contact is made with a live heater circuit.

1. Loosen two of the three setscrews on the 3-0067 Outer Magnetic Drive Support. The 3-0066 Outer Magnetic Drive Rotator Assembly will fall off. It may be necessary to loosen the 3-0061 Magnetic Drive Sprocket to completely remove the rotator.



CAUTION: The inner shaft is composed of extremely powerful magnets. If these magnets are allowed to get too close to steel objects the magnetic force may cause injury or damage to the shaft. Also keep the shaft away from metal filings, as they will adhere to the shaft and cause premature wear.

2. To remove the 3-0056 Upper Bearing, remove the C-0090 Retaining Ring and slide the bearing out. Expect for excess wear and replace if needed.
3. To remove the C-0087 Lower Bearing, remove the C-0091 Retaining Ring and slide the bearing out. Inspect for excessive runout or rough operation and replace if necessary.
4. Removal of the 3-0052 Inner Magnet Sleeve is usually not necessary and is not recommended.
5. Assembly is the reverse of disassembly.

Removal of the Magnetic Drive Housing



Refer to drawing 3-0063 Magnetic Drive Assembly in Chapter 6 for servicing all magnetic drive components.

CAUTION: Make certain that the power to the instrument is disconnected before servicing the magnetic drive rotator. The rotator is very close to the heater terminals and severe shock or electrocution could occur if contact is made with a live heater circuit.

1. Loosen two of the three setscrews on the 3-0067 Outer Magnetic Drive Support. The 3-0066 Outer Magnetic Drive Rotator Assembly will fall off.



CAUTION: The inner shaft is composed of extremely powerful magnets. If these magnets are allowed to get too close to steel objects the magnetic force may cause injury or damage to the shaft. Also keep the shaft away from metal filings, as they will adhere to the shaft and cause premature wear.

Use care when working near the heater terminals. They are easily bent or broken.

2. With a spanner wrench, loosen the 3-0064 Lock Ring is found in the recessed hole in the bottom of the pressure vessel.
3. Push the 3-0062 Magnetic Drive Housing up through the pressure vessel bore and out the top. It may be necessary to gently tap the housing with a hammer to break it loose if it is cemented in place. If cement contamination is severe, cement may have to be removed out through the bore of the pressure vessel before the housing can be removed.
4. Replace the C-0111 Teflon o-ring prior to assembly.
5. Assembly is the opposite of disassembly.

Heater Replacement



The 3-0022 Heater should be replaced if a hole burns through the sheath or if the heater fails to heat. The replacement steps are listed below.

CAUTION: Make certain that the power to the instrument is disconnected before servicing the heater. Severe shock or electrocution could occur if contact is made with a live heater circuit.

2. Remove the 3-00?? Upper Heater Spreader from the pressure vessel bore.
3. Remove the 3-00?? Contact Pin Shield.
4. Remove wires from the 3-0027 Contact Pins and the 3-0029 Ground Pin and note to which pin each wire is connected.
5. Remove the 3-00?? Lower Heater Spreader.
6. Remove the 3-0066 Magnetic Drive Rotator Assembly as described above.
7. Remove wires from heater terminals.

A deep socket or a piece of 3/8-inch tubing may be placed over the heater terminals and used as punch to loosen the heater ferrules.

8. Remove both C-0250 Heater Nuts.
9. Tap on heater ferrules until loosened then pull heater out through bore of pressure vessel.
10. Make certain that the 3-0025 Heater Gaskets came out with the heater. If the gaskets did not come out, a 7/16-inch bolt or rod inserted through the bottom of the heater holes will normally snag the gasket and push it out. In lieu of this, a screwdriver may be used to push the gasket out. Be careful not to damage the sealing surface inside the heater holes.
11. Clean the bottom of the pressure vessel and the heater holes before installing new heater. Assembly is the reverse of assembly.

With the 3-0025 Heater Gaskets removed from the heater insure that the heater is bent so that it drops through the heater holes with minimal effort and that the heater coils lay flat against the pressure vessel bore. Forcing the heater into the holes usually deforms the heater and makes the slurry rub the heater. An installed heater is almost impossible to bend.

Troubleshooting

The following section consists of a table listing possible remedies for the most common consistometer problems.

Symptom	Cause	Remedy
System builds pressure but will not hold pressure	Leak PRESSURE RELEASE and AIR TO CYLINDER valves are not closed tightly PRESSURE RELEASE or AIR TO CYLINDER valves worn out.	Check fittings for leaks and tighten fittings. Heater ferrules, contact pins, and magnetic drive housing are also possibilities. Close valves tightly. Replace valve stem or entire valve. PRESSURE RELEASE valve is most likely to wear out.
System builds pressure and oil runs out between pressure vessel and top plug.	Metal o-ring (C-0061) is scratched or dented. O-ring sealing surfaces and/or seal shaft are worn, pitted, or scratched.	Replace o-ring. Lap o-ring sealing surfaces. A lapping kit is available from CTE.
Pump strokes but little or no pressure is obtained.	Valve open, severe leak, blown rupture disc. Pressure vessel has trapped air. Oil reservoir is empty OIL SUPPLY valve is closed (dual consistometer only) AIR SUPPLY valve not opened or air not connected to instrument. Severely clogged low-pressure filter. Faulty pump check valve. No air supplied to air operated valve (if so equipped).	Locate problem and correct. Open thermocouple connector slightly and release trapped air. Fill reservoir with oil Open OIL SUPPLY valve. Connect air supply and open AIR SUPPLY valve. Replace low-pressure filter element. Clean and/or overhaul pump outlet check valve. Check air lines leading to valve. Check valve solenoid valve. Restore air supply.
Pump builds and	If not oil is coming from	Add oil to reservoir.

Symptom	Cause	Remedy
maintains pressure to a certain level than then stops.	<p>pump muffler, oil reservoir ran dry.</p> <p>If oil is coming from pump muffler, the pump high-pressure seal is probably worn out.</p>	Overhaul or replace pump.
Pressure cannot be released.	Stainless steel lines (3/8 inch) are plugged with cement.	Remove lines and inspect for blockage. Replace any that are plugged.
Air operated valves will not release pressure on units equipped with automatic pressure control.	<p>If valves cannot be heard exhausting air, the problem is a faulty solenoid valve on the air-operated valve.</p> <p>If valves can be heard exhausting air, the problem is most likely a plugged capillary tube connected to the exit port of the valve.</p>	<p>Repair or replace solenoid valve.</p> <p>Replace capillary tube.</p>
Slurry cup rubs on heater or heater spreader.	<p>Heater does not sit flush with bore of pressure vessel or heater spreaders missing.</p> <p>Magnet drive bearings are worn.</p> <p>Missing pin on slurry cup base.</p>	<p>Bend heater to sit flush with bore of vessel and add heater spreaders.</p> <p>Check bearings on inner magnet shaft and replace if necessary.</p> <p>Replace pin or base.</p>
Slurry cup will not turn.	<p>Magnetic drive severely contaminated with cement.</p> <p>Blown fuse on motor control board.</p> <p>Faulty motor or controller.</p> <p>Broken drive belt.</p>	<p>Remove magnetic drive plug and inner magnet shaft and clean magnetic drive thoroughly.</p> <p>Check fuses on motor control board located inside electrical box.</p> <p>Replace as necessary.</p> <p>Replace drive belt.</p>
Erratic motor speed control.	<p>Magnetic pickup holder has come loose.</p> <p>Worn out bearings in magnetic drive outer rotator.</p>	<p>Check magnetic pickup holder on bottom magnetic drive and tighten if necessary.</p> <p>Check rotator for excessive runout or wobble with motor running. Remove rotator and inspect bearings. Replace if necessary.</p>

Symptom	Cause	Remedy
Consistency display always indicates zero.	<p>Blown fuse.</p> <p>Measure voltage between blue and yellow contact pins. If voltage is zero, the 15 VDC power supply has failed or there is an open circuit in the blue or yellow wires.</p> <p>Broken potentiometer mechanism resistor.</p> <p>Broken or corroded potentiometer connecting strips.</p> <p>Broken, severely worn, or corroded contact springs.</p> <p>Broken or corroded ground pin.</p> <p>Faulty CONSISTENCY SPAN potentiometer.</p>	<p>Replace fuse.</p> <p>Check the power supply output. If output is approximately 15 VDC, use an ohm meter to check for open circuits in the yellow or blue wires. Isolate and correct. If power supply voltage is zero when the yellow and blue wires are removed, replace the power supply. If the power supply voltage is 0 VDC when the wires are connected but 15 VDC when the wires are disconnected, there is a short circuit in the yellow wire.</p> <p>With the potentiometer out of the instrument, check the resistance of the potentiometer resistor. If it is greater than 200Ω, replace the resistor.</p> <p>Replace.</p> <p>Inspect and replace if necessary.</p> <p>Check electrical continuity between ground pin and cylinder. If continuity does not exist, replace ground pin.</p> <p>Check electrical continuity between the two yellow connections on the potentiometer. If no continuity exists, replace the potentiometer.</p>
Consistency meter always displays approximately 150 Bc.	Shorted contact pin.	Check electrical continuity between contact pins and cylinder. If continuity exists, replace contact pin. This does not apply to the ground pin, which always has continuity with cylinder.
Heater will not get hot.	<p>Blown fuse.</p> <p>Loose heater wire.</p>	<p>Check fuses inside electrical box. Replace any that are blown.</p> <p>Check heater terminals for loose</p>

Symptom	Cause	Remedy
		wires and reconnect if necessary. Replace. Replace.
Temperature display is erratic.	Faulty heater. Faulty solid state relay. Faulty thermocouple.	Replace thermocouple.
	Loose connection in thermocouple wiring.	Check for loose wiring and correct if necessary.
Temperature displays and unusually high number (>1500°F)	Open circuit in thermocouple.	Replace thermocouple.
	Open circuit in thermocouple circuitry	Check thermocouple circuitry for open circuits or loose connections. Correct if necessary.
Oil comes out pump muffler. Pump may or may not stroke.	AIR TO CYLINDER valve has been opened while cylinder is pressurized, flooding the air lines and pump pneumatic side with oil.	Remove air lines and drain oil. Remove pump and disassemble pump pneumatic side to remove oil. If contamination is not too severe, you may let the pump stroke under no pressure until the oil is removed. This tends to create an oil mist that will fill the entire lab.
	Air lubricator is putting too much oil in the pump air.	Adjust lubricator to supply less oil.

The following is a table of frequently used replacement parts along with the CTE part numbers. The following parts are used on both the single and dual consistometers except where otherwise noted.

Description	Part Number
Plug Bail	3-0048
Seal Shaft Retaining Nut	3-0044
Swivel Arm	3-0091
Swivel Arm Nylon Bearing	3-0099
Swivel Arm Pulley	C-0303
Bearing	C-0087
Eye Bolt	C-0300
Pulley Shaft, (long)	3-0092
Pulley Shaft, (short)	3-0093
Cable Assembly	3-0086
Cable Swivel Assembly	C-0299
Slurry Cup Assembly	2-0030
Slurry Cup Sleeve	2-0034
Slurry Cup Base	2-0034
Cup Base Plug	2-0033
Cup Lock Ring (Low temperature)	2-0039
Cup Lock Ring (High temperature)	3-0031
Cup Diaphragm Collar	2-0036
Diaphragm	2-0041
Diaphragm Support	2-0037
Slurry Cup Paddle	2-0031
Cup Shaft (short)	2-0032
Drive Shaft Disc	2-0040
Drive Bar	2-0038
Cup Shaft (long)	3-0032
Stop Arm	2-0058
Spring Sleeve	2-0056
Shaft Bearing Retainer	2-0064
Resistor	2-0062
Collar, Spring w/Screws	2-0057
Potentiometer Slider	2-0077
Calibration Spring	2-0060
Spring Adjuster	2-0053
Oil Reservoir	3-0042
Upper Heater Spreader	3-0035
Lower Heater Spreader	3-0043

Description	Part Number
Heater Assembly Gasket	3-0025
Calibration Device Assembly	
Contact Pin	3-0027
Seal Shaft	3-0045
Cylinder Plug	3-0036
Contact Pins Shield	3-0047
Spring Adjustor Clamp	2-0054
Dip Tube	3-0046
Cooling Coil Assembly	C-0372
Thermocouple	3-0026
Packing Ring	2-0044
Hub Cap	2-0042
Diaphragm Hub	2-0043
Potentiometer Mechanism Assembly	2-0050
Contact Strip	2-0051
Heater Element	3-0023
Low Pressure Filter Assembly	
Cylinder Leg	3-0038
Element, High Pressure Filter	2-0076
High Pressure Filter Assembly	2-0071
Filter Housing	2-0072
Filter Seat	2-0073
Seat Retainer	2-0074
Potentiometer Contact Spring Set	2-0059
Pressure Vessel	3-0021
Filter Nipple	2-0075
Motor Pulley	C-0082
Motor Shaft Bushing	C-0381
Cylinder Mounting Ring	3-0037
Copper Gasket, Slurry Cup Assembly	3-0033
Rotator Sprocket	3-0061
Retainer, Magnetic Drive Housing	3-0064
Magnet Shaft Bearing	3-0073-1
Upper Bronze Bearing	3-0072
Thrust Ring	3-0071
Washer, Inner Mag Drive Shaft	3-0074-6
Cup Table	3-0034
Spacer	3-0058
Lower Bearing Spacer	3-0057
Upper Bearing Spacer	3-0059
Teflon Bearing, Rotator Assembly	3-0056
Bearing, Stainless Steel, Rotator Assembly	C-0087
Plug Handle	2-0022

Description	Part Number
Outer Magnet Assembly	3-0051
Seal Plug Assembly	3-0065
Lower Spacer	3-0057
Holder, Rotator Assembly	3-0054
Upper Spacer	3-0059
Pin, Rotator Assembly	3-0055
Magnetic Drive Rotator Assembly	3-0051
Shaft Assembly, Magnetic Drive	3-0070
Seal Nut	3-0065-2
Seal Plug	3-0065-1
Timer	C-0200
Pressure Transducer	C-0022
Potentiometer, 100 ohm	C-0160
Hex Key Set	
Valve, High Pressure, ¼ inch	C-0004-1
Valve, High Pressure, 3/8 inch	C-0005-1
O-ring, Teflon	C-0006
Roll Pin	C-0007
Shear Pin	C-0008
Roll Pin	C-0009
Fuse, 2A	C-0010
Air Pressure Regulator	C-0021
Pressure Transducer Cable	C-0022-1
Solenoid Valve	C-0024
Gland, ¼ High Pressure Tubing	C-0038
Collar, ¼ High Pressure Tubing	C-0039
Gland, 3/8 High Pressure Tubing	C-0042
Collar, 3/8 High Pressure Tubing	C-0043
Rupture Disc, 32000 psi	C-0046
Safety Head	C-0146
Valve, Brass	C-0056
O-ring, metal	C-0061
O-ring	C-0062
Switch, Circuit Breaker	C-0075
Switch	C-0076
Solid State Relay	C-0080
Bearing, Pot Mech Frame	C-0085
Bearing, Paddle Shaft	C-0086
PC Board	C-0089
Retaining Ring	C-0090
Retaining Ring	C-0091
Gasket, Low Pressure Filter	C-0101
Filter Element, Low Pressure	C-0102

Description	Part Number
Roll Pin	C-0108
O-ring	C-0109
Retaining Ring	C-0110
O-ring, Teflon	C-0111
Power Supply, +-15 VDC	C-0118
Contactator	C-0212
O-ring	C-0135
Touch Screen Monitor	C-0145
O-ring	C-0147
Thermocouple Receptacle	C-0167
Printer Cable	C-0172
Switch	C-0186
Receptacle, Pot Mech Calibrator	C-0222
Alarm	C-0223
Switch, pushbutton	C-0227
Button, for C-0227 switch	C-0228
Lamp, for C-0227 switch	C-0229
Fuse, 20A	C-0234
Fuse, 1A	C-0235
Fuse, 3A	C-0236
Backup Ring	C-0240
Disc, Rupture, 45000 psi	C-0246
Belt, timing	
Mineral Oil, gallon	C-0248
Heater nut	C-0250
Touch screen power supply	C-0336
Eye Bolt	C-0300
O-ring	C-0301
Switch	C-0302
Wire rope pulley	C-0303
Lock Nut	C-0304
Filter Housing (low pressure)	C-0322
Fan	C-0324
Pressure Gauge	C-0364
Muffler	C-0368
Filter, Regulator, Lubricator Unit (FRL)	C-0369
Pump	C-0370
O-ring	C-0374
Electric Motor	C-0377
Motor Controller	C-0379
Speed Control Gear	
Tachometer	C-0388
Solenoid Valve	C-0389

Description	Part Number
Magnetic Pickup	C-0390
Cable, for C-0390 Magnetic Pickup	C-0391
Air Operated Valve	C-0392
Consistency Meter	C-0394-1
Potentiometer, motor speed control	C-0397
Resistor, motor controller	C-0398
Pressure Gauge, 50000 psi	C-0465
Pressure Gauge, 30000 psi	C-0466
Temperature controller, auxiliary	C-0505
Drip Pan (dual)	3-0041-10
Stop, Mounting Frame	2-0063

THE INFORMATION CONTAINED IN THIS DRAWING IS THE SOLE PROPERTY OF CEMENT TEST EQUIPMENT, INC. ANY REPRODUCTION IN PART OR WHOLE WITHOUT THE WRITTEN PERMISSION OF CEMENT TEST EQUIPMENT IS PROHIBITED.

REV.	DESCRIPTION	DATE	APPROVED

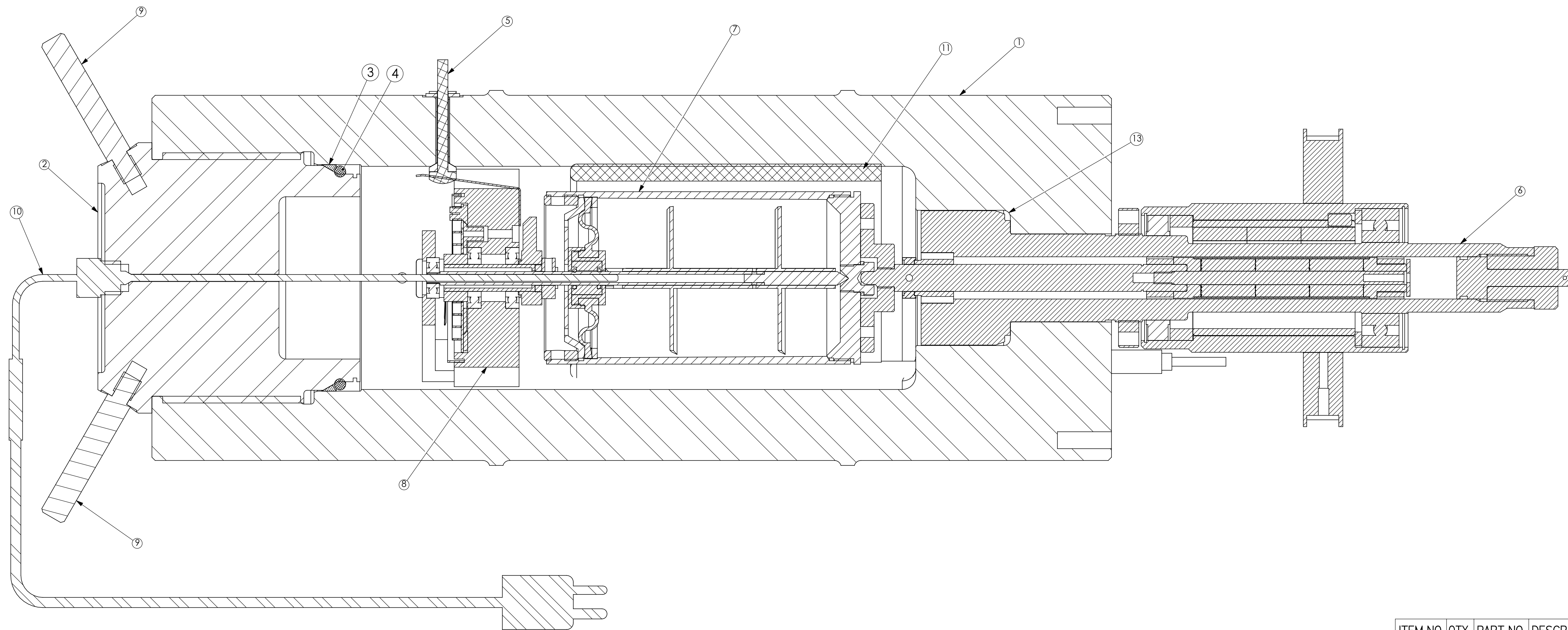

SECTION A-A
SCALE 1:1

ITEM NO.	QTY.	PART NO.	DESCRIPTION
1	1	11-0021	CYLINDER
2	1	11-0022	PLUG
3	1	11-0023	SEAL RING
4	1	C-0125	O-RING
5	1	11-0026	CONTACT PIN
6	1	3-0063	MAGNETIC DRIVE ASSY
7	1	2-0030	SLURRY CUP ASSY
8	1	2-0050	POTENTIOMETER MECHANISM ASSY
9	2	4-0026	HANDLE
10	1	8-0011	THERMOCOUPLE
11	1	3-0023	HEATER
12	1	11-0027	GROUND PIN (NOT SHOWN)
13	1	C-0111	O-RING (NOT SHOWN)

UNLESS OTHERWISE SPECIFIED DIMENSIONS ARE IN INCHES TOLERANCES ARE:		CAD GENERATED DRAWING DO NOT MANUALLY UPDATE		CEMENT TEST EQUIPMENT, INC.	
FRACTIONS	DECIMALS	ANGLES	APPROVALS	DATE	CYLINDER ASSEMBLY
±1/32	.001	±1°	DRAWN	3-17-98	
			CHECKED	3-17-98	
			RES'P ENG	3-17-98	
MATERIAL			MFG ENG	3-17-98	REV. B
FINISH			QUAL ENG	3-17-98	
NEXT ASSY	USED ON	DO NOT SCALE DRAWING	SCALE	1:1	DWG. NO. 11-0020
APPLICATION					SHEET 1 OF 1

THE INFORMATION CONTAINED IN THIS DRAWING IS THE SOLE PROPERTY OF CEMENT TEST EQUIPMENT, INC. ANY REPRODUCTION IN PART OR WHOLE WITHOUT THE WRITTEN PERMISSION OF CEMENT TEST EQUIPMENT, INC. IS PROHIBITED.

REVISIONS			
REV.	DESCRIPTION	DATE	APPROVED

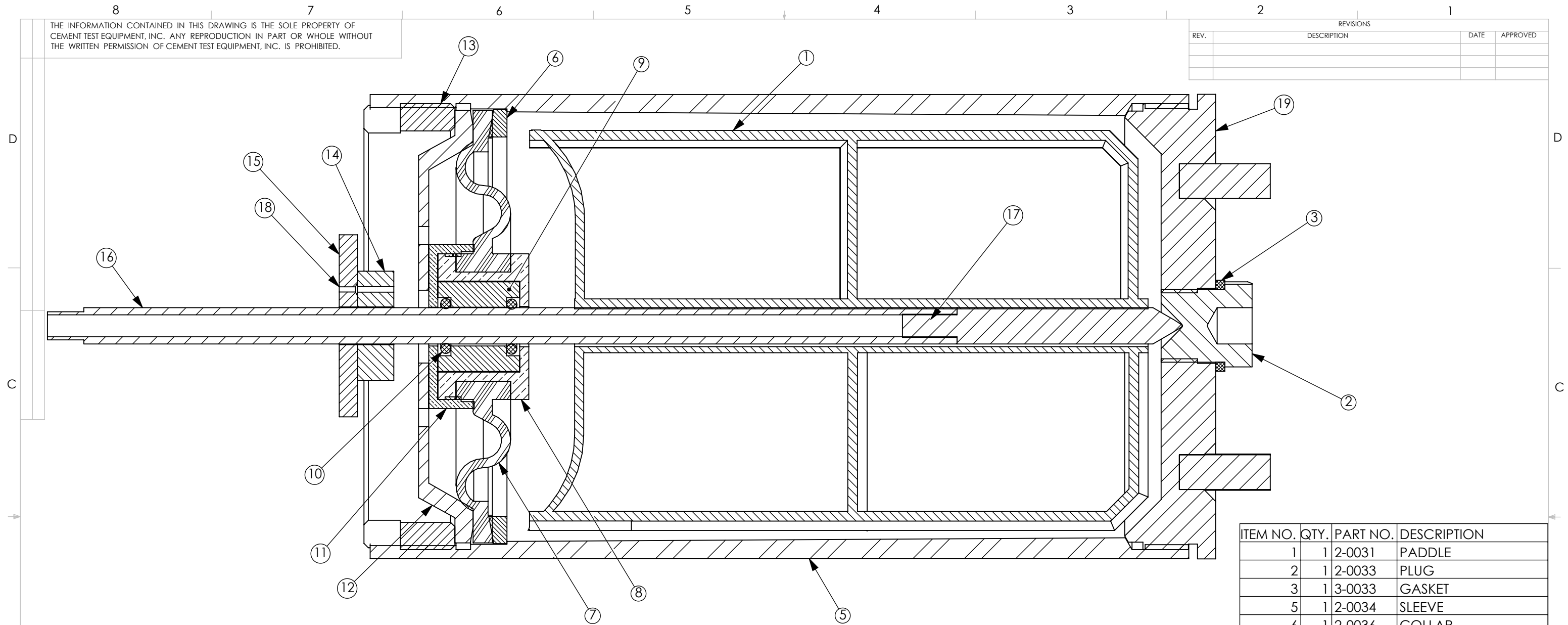

SECTION A-A
SCALE 3 : 2

ITEM NO.	QTY.	PART NO.	DESCRIPTION
1	1	2-0031	PADDLE
2	1	2-0033	PLUG
3	1	3-0033	GASKET
5	1	2-0034	SLEEVE
6	1	2-0036	COLLAR
7	1	2-0041	DIAPHRAGM
8	1	2-0043	DIAPHRAGM HUB
9	1	2-0044	RING
10	2	C-0006	O-RING
11	1	2-0042	HUB CAP
12	1	2-0037	DIAPHRAGM SUPPORT
13	1	2-0039	LOCK RING
14	1	2-0040	DRIVE SHAFT DISC
15	1	2-0038	DRIVE BAR
16	1	2-0032	PADDLE SHAFT
17	1	C-0007	ROLL PIN
18	1	C-0008	SHEAR PIN
19	1	2-0045	

UNLESS OTHERWISE SPECIFIED
DIMENSIONS ARE IN INCHES
TOLERANCES ARE:
FRACTIONS DECIMALS ANGLES
+1/32 .XX+-.01 +-1
.XXX +-.005

CAD GENERATED DRAWING,
DO NOT MANUALLY UPDATE

APPROVALS	DATE
DRAWN CCD	3-2-98
CHECKED CCD	3-2-98
RESP ENG CCD	3-2-98
MFG ENG CCD	3-2-98
QUAL ENG CCD	3-2-98

CEMENT TEST EQUIPMENT, INC.

SLURRY CUP ASSEMBLY

SIZE B DWG. NO. 2-0030 REV. A
SCALE 3:2 CAD FILE: SHEET 1 OF 1

NEXT ASSY	USED ON
APPLICATION	DO NOT SCALE DRAWING

THE INFORMATION CONTAINED IN THIS DRAWING IS THE SOLE PROPERTY OF CEMENT TEST EQUIPMENT, INC. ANY REPRODUCTION IN PART OR WHOLE WITHOUT THE WRITTEN PERMISSION OF CEMENT TEST EQUIPMENT, INC. IS PROHIBITED.

REVISIONS			
REV.	DESCRIPTION	DATE	APPROVED

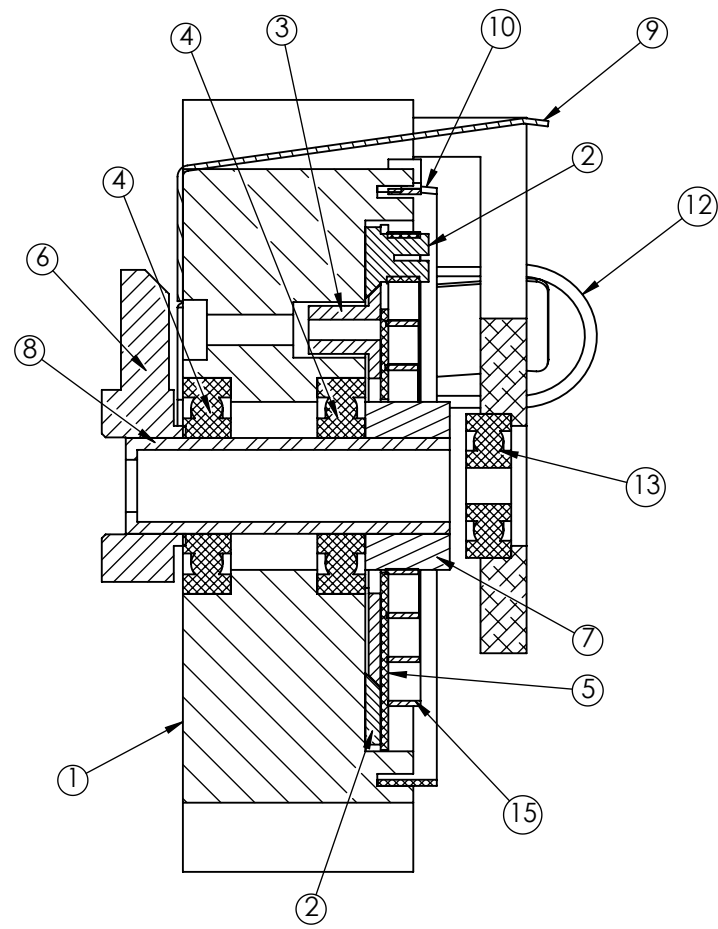

SECTION A-A
SCALE 1:1

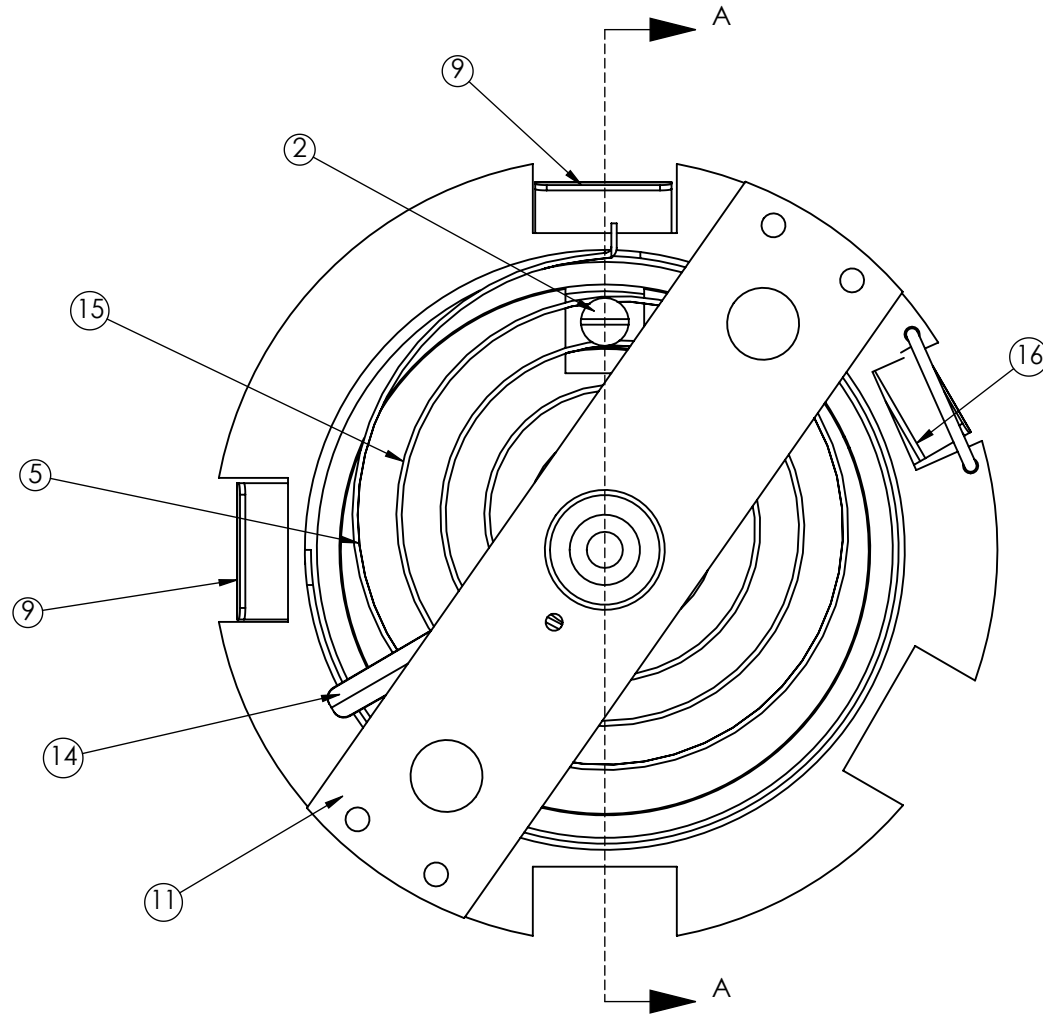

ITEM NO.	QTY.	PART NO.	DESCRIPTION
1	1	2-0052	Mounting Frame
2	1	2-0053	Spring Adjuster
3	1	2-0054	Spring Adjuster Clamp
4	2	C-0085	Bearing
5	1	2-0055	Insulator
6	1	2-0058	Stop Arm
7	1	2-0057	Spring Collar
8	1	2-0056	Spring Sleeve
9	2	2-0059-1	Contact Pin Spring
10	1	2-0064	Shaft Bearing Retainer
11	1	2-0063	Mounting Frame Stop
12	1	C-0086	Bearing
13	1	2-0077	Potentiometer Slider
14	1	2-0060	Spring
15	1	2-0059-2	Ground Pin Spring
16	1	2-0061	Resistor
17	1	2-0066	Ground Wire (not shown)

UNLESS OTHERWISE SPECIFIED
DIMENSIONS ARE IN INCHES
TOLERANCES ARE:

FRACTIONS DECIMALS ANGLES
+1/32 .XX+-.01 +-1
.XXX +-.005

MATERIAL

FINISH

DO NOT SCALE DRAWING

CAD GENERATED DRAWING,
DO NOT MANUALLY UPDATE

APPROVALS DATE

DRAWN CCD 3-27-97

CHECKED CCD 3-27-97

RESP ENG CCD 3-27-97

MFG ENG CCD 3-27-97

QUAL ENG CCD 3-27-97

CEMENT TEST EQUIPMENT, INC.

POTENTIOMETER MECHANISM ASS'Y

SIZE DWG. NO. 2-0050

SCALE 1:1 CAD FILE:

REV. A

SHEET 1 OF 1

NEXT ASSY	USED ON	APPLICATION

THE INFORMATION CONTAINED IN THIS DRAWING IS THE SOLE PROPERTY OF CEMENT TEST EQUIPMENT, INC. ANY REPRODUCTION IN PART OR WHOLE WITHOUT THE WRITTEN PERMISSION OF CEMENT TEST EQUIPMENT IS PROHIBITED.

REVISIONS			
REV.	DESCRIPTION	DATE	APPROVED

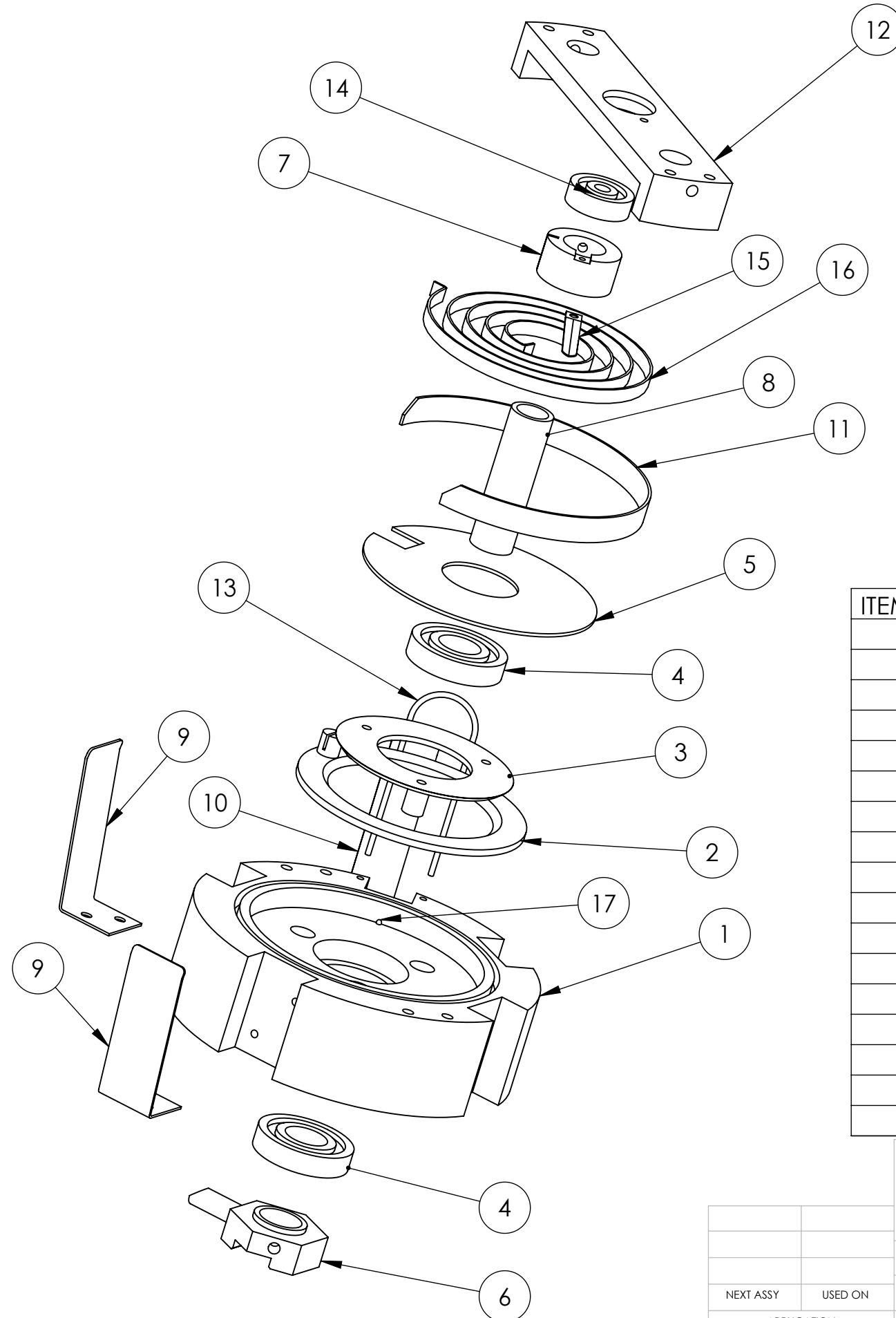

ITEM NO.	QTY.	PART NO.	DESCRIPTION
1	1	2-0052	TEFLON BASE
2	1	2-0053	SPRING RETAINER
3	1	2-0054	SPRING RETAINER CLAMP
4	2	C-0085	BEARING
5	1	2-0055	INSULATOR
6	1	2-0058	STOP ARM
7	1	2-0057	WIPER BASE
8	1	2-0056	SHAFT
9	2	2-0059-1	CONTACT SPRING
10	1	2-0059-2	GROUND SPRING
11	1	2-0061	RESISTOR
12	1	2-0064	BEARING HOUSING
13	1	2-0063	HANGER WIRE
14	1	C-0086	UPPER BEARING
15	1	2-0077	WIPER
16	1	2-0060	SPRING
17	1	2-	GROUND WIRE

UNLESS OTHERWISE SPECIFIED DIMENSIONS ARE IN INCHES TOLERANCES ARE:
 FRACTIONS DECIMALS ANGLES
 ±1/32 .XX ±.01 ±1
 .XXX ±.005

CAD GENERATED DRAWING, DO NOT MANUALLY UPDATE	
APPROVALS	DATE
DRAWN CCD	
CHECKED CCD	
RESP ENG CCD	
MFG ENG	
QUAL ENG	

CEMENT TEST EQUIPMENT, INC.
POTENTIOMETER MECHANISM EXPLODED VIEW
 SIZE B DWG. NO. 2-0050-EXP REV.
 SCALE CAD FILE: SHEET 1 OF 1

NEXT ASSY	USED ON
APPLICATION	DO NOT SCALE DRAWING

REVISIONS			
REV.	DESCRIPTION	DATE	APPROVED
C	REPLACE UPPER PLASTIC BEARING WITH BALL BRG.	11-6-98	CCD

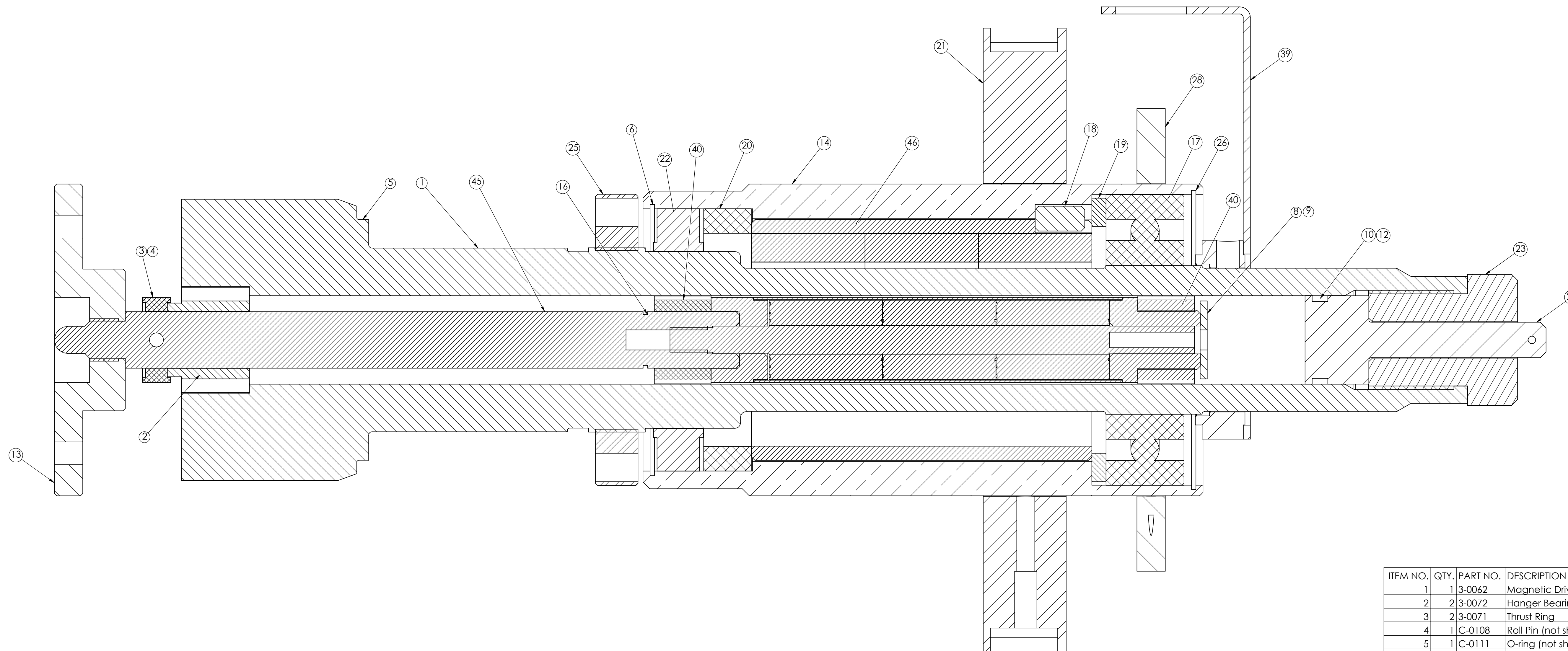

SECTION A-A
SCALE 2 : 1

ITEM NO.	QTY.	PART NO.	DESCRIPTION
1	1	3-0062	Magnetic Drive Housing
2	2	3-0072	Hanger Bearing, Bronze
3	2	3-0071	Thrust Ring
4	1	C-0108	Roll Pin (not shown)
5	1	C-0111	O-ring (not shown)
6	1	C-0090	Snap Ring (not shown)
8	1	3-0074-6	Washer
9	1	3-0074-5	8-32 Screw (not shown)
10	1	C-0109	O-ring (not shown)
12	1	C-0240	Backup ring (not shown)
13	1	3-0034-1	Cup Table
14	1	3-0054	Outer Magnet Holder
16	1	C-0110	Snap Ring (not shown)
17	1	C-0087	Lower Bearing
18	1	3-0055	Anti-rotation Pin
19	1	3-0057	Lower Spacer
20	1	3-0056-1	Bearing Spacer
21	1	3-0061	Drive Sprocket
22	1	C-0571	Upper Bearing
23	1	3-0065-2	Seal Plug Retainer
24	1	3-0065-1	Seal Plug
25	1	3-0064	Lock Ring
26	1	C-0091	Snap Ring (not shown)
28	1	3-0068	Tachometer Gear
39	1	3-0069-1	Rotator Support
40	2	3-0073	Bearing
45	1	3-0070	Inner Magnet Shaft
46	1	3-0051	Outer Magnet Ass'y

UNLESS OTHERWISE SPECIFIED DIMENSIONS ARE IN INCHES TOLERANCES ARE:	CAD GENERATED DRAWING. DO NOT MANUALLY UPDATE	CEMENT TEST EQUIPMENT, INC.
FRACTIONS DECIMALS ANGLES ±1/32 .001 ±.01 1°	APPROVALS DATE	
MATERIAL	DRAWN	
FINISH	CHECKED	
NEXT ASSY USED ON	RES'P ENG	
APPLICATION	MFG ENG	
DO NOT SCALE DRAWING	QUAL ENG	
	DATE	DWG. NO. 3-0063
	SCALE 1:1	CAD FILE: SHEET 1 OF 1

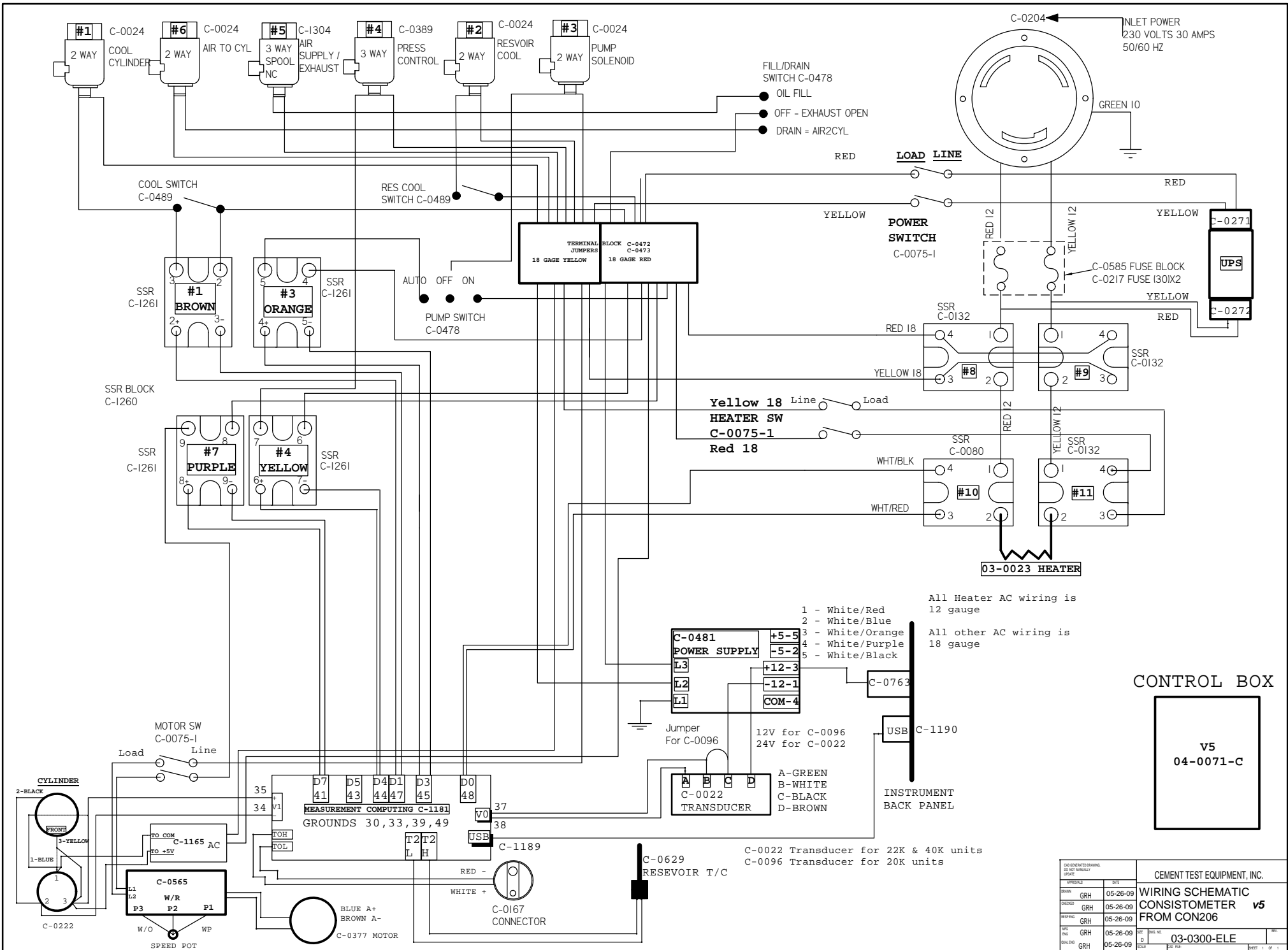

- FILL/DRAIN SWITCH C-0478
- OIL FILL
- OFF - EXHAUST OPEN
- DRAIN = AIR2CYL

Yellow 18 Line Load
 HEATER SW C-0075-1
 Red 18

- All Heater AC wiring is 12 gauge
 All other AC wiring is 18 gauge
- 1 - White/Red
 - 2 - White/Blue
 - 3 - White/Orange
 - 4 - White/Purple
 - 5 - White/Black

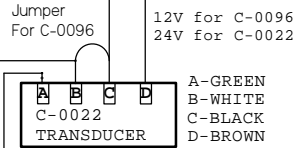
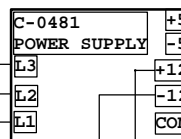

CONTROL BOX

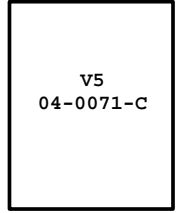

C-0022 Transducer for 22K & 40K units
 C-0096 Transducer for 20K units

C/C/OPERATED/DRIVER/DO NOT REBALLY/COVER	
APPROVAL	SITE
DRAWN GRH	05-26-09
DESIGN GRH	05-26-09
REVISION GRH	05-26-09
REV GRH	05-26-09
DATE GRH	05-26-09
DRAWING GRH	05-26-09
DATE	05-26-09

CEMENT TEST EQUIPMENT, INC.

**WIRING SCHEMATIC
 CONSISTOMETER v5
 FROM CON206**

03-0300-ELE

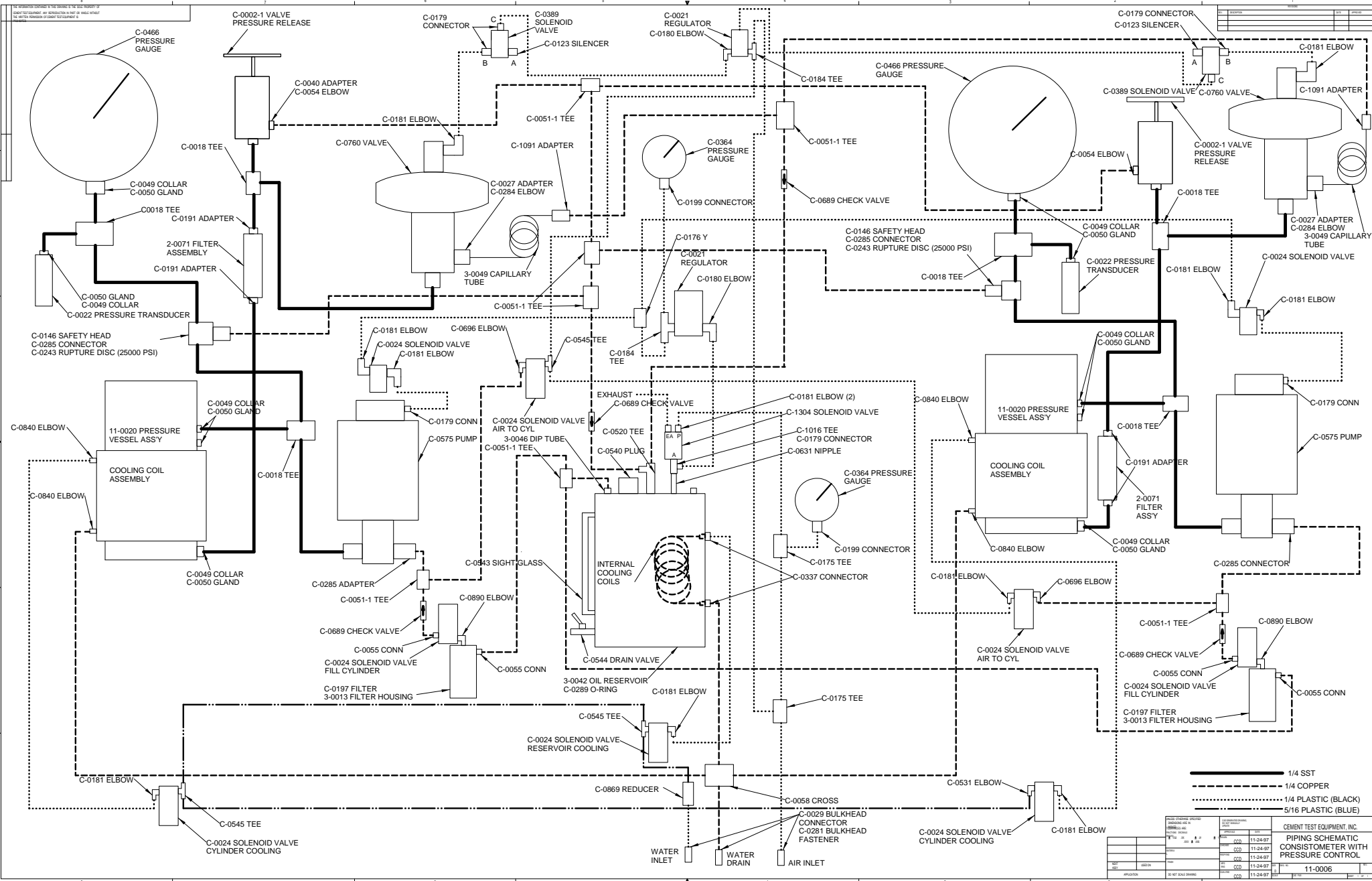

NO.	DESCRIPTION	QTY	UNIT

————— 1/4 SST
 - - - - - 1/4 COPPER
 1/4 PLASTIC (BLACK)
 - · - · - 5/16 PLASTIC (BLUE)

DATE CHANGED		BY		REASON	

CEMENT TEST EQUIPMENT, INC.
 PIPING SCHEMATIC
 CONSISTOMETER WITH
 PRESSURE CONTROL
 11-0006