



# LC 950 RB

## User Product Manual

LifeCore LC-950 Recumbent Bike

### Customer Service

Toll Free (888) 815 – 5559

[Service@lifecorefitness.com](mailto:Service@lifecorefitness.com)

[www.lifecorefitness.com](http://www.lifecorefitness.com)

LifeCore Fitness Inc.

2575 Pioneer Avenue, Suite 101,

Vista, CA 92081

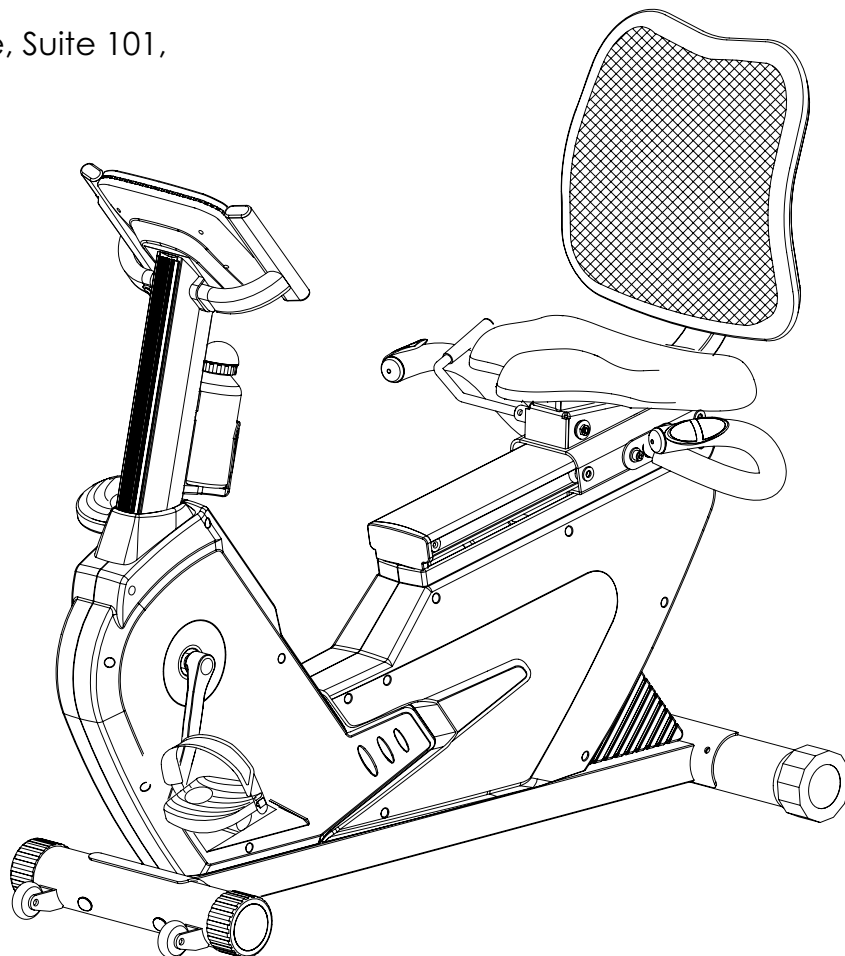

# Important Safety Instruction

We at LifeCore fitness would like to thank you for your recent purchase of a LifeCore exercise bike, and we hope that our product inspires and motivates you to accomplish your fitness goals. Please read the users owners manual and orient yourself with the unit before you use the product to get a better understanding of your exercise machine.

The LifeCore 950RB is an exercise bike that simulates the movements of riding a bicycle at different speeds and resistance levels. Before the machine is ever used, it is recommended that a physician be consulted regarding any user(s) health condition, especially if the user(s) has a family history of cardio vascular conditions. If, at any time while exercising, a user experiences shortness of breath, dizziness, faintness, chest pains, or any discomforts, he or she must stop immediately and contact his or her physician.

- ❖ It is the sole responsibility of the owner(s) to make sure that any user using this product has fully read and understands the warnings and safety precautions.
- ❖ Unit maximum weight limit is 300LBS.
- ❖ Before working out remember to perform stretching exercises to avoid injury.
- ❖ Do not use this exercise bike outdoors or in areas of high humidity.
- ❖ Only operate the machine in a dry well ventilated room.
- ❖ Always examine the unit prior to exercising to ensure parts are in good working order.
- ❖ After every workout use the preventative maintenance tips to keep the products in good working order.
- ❖ Make sure that all components are fastened securely including but not limited to seat, pedals, handlebars, or any electric components.
- ❖ Unit should always be plugged into a surge protector.
- ❖ No more than one person should ever use the product at a time.
- ❖ Pets should never be allowed near unit.
- ❖ Children should never be left unsupervised near unit.
- ❖ Always use appropriate clothing and shoes to exercise. Never use heels, spikes, cleats, bare feet, sandals, socks or stockings while using the exercise machine.
- ❖ Keep hands and feet away from any moving parts at all times.
- ❖ Make sure that the unit is on a solid level surface. It is recommended that a mat be placed under the machine to protect the floor, carpet or any solid surface that the machine is placed on. Also to protect the machine from a hard surface.
- ❖ Whenever mounting or dismounting from the exercise machine, make sure that the unit is not in motion and use caution to prevent injury. Use the handlebars or a helper whenever additional stability is required.
- ❖ Never place any open containers of any type directly on the unit, only containers with lids are recommended to be used with the appropriate water bottle holder.
- ❖ Keep exercise bike clear of any obstructions, heavy machinery, and never place objects on or against machine.
- ❖ Do not place machine in an area of high voltage or electromagnetic fields.
- ❖ Failure to follow these instructions will void the units warranty and the manufacture or distributor assumes on responsibility for personal injury or property damages related to the product if unit is ever used incorrect or for other reasons other than exercise.

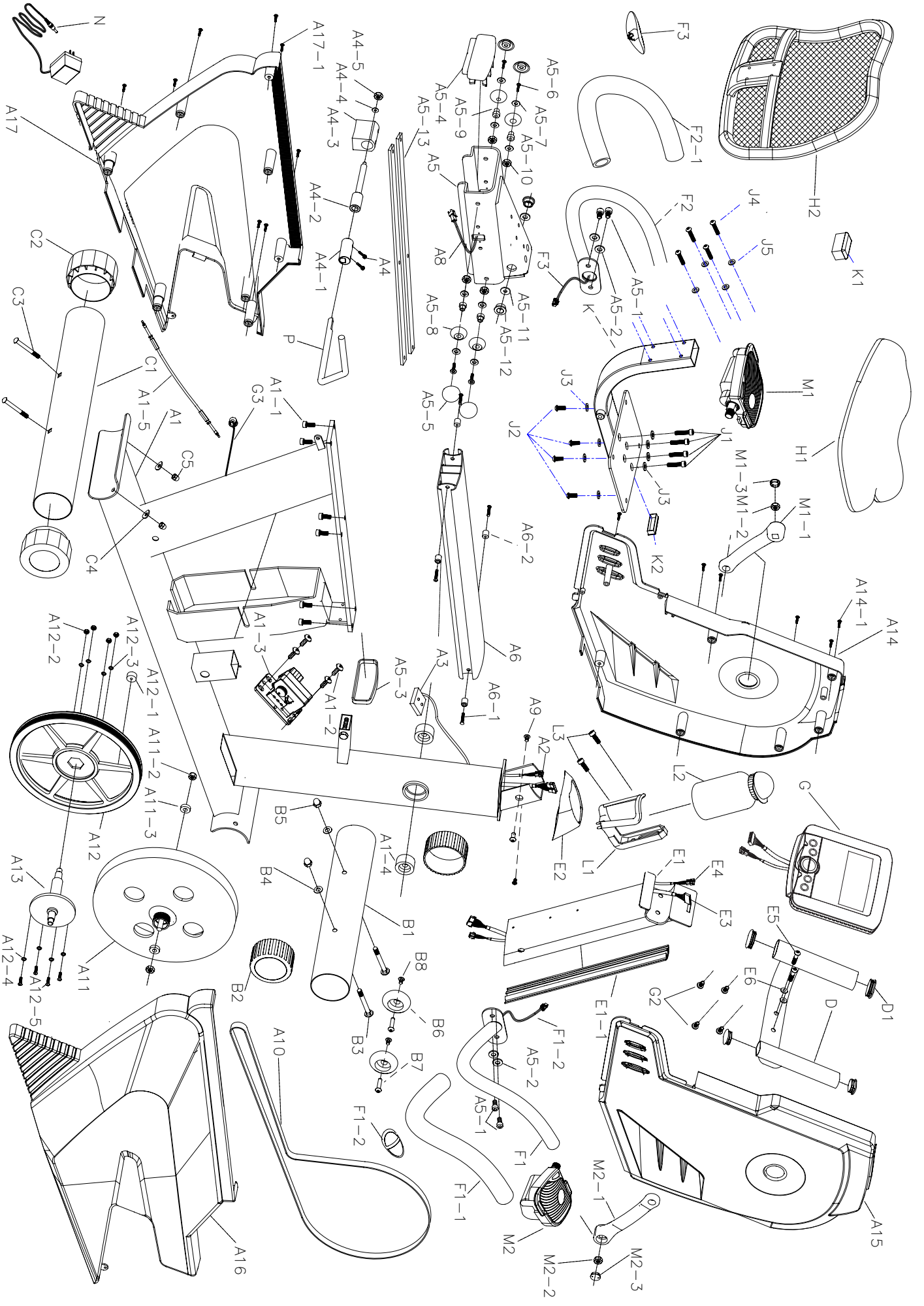

## 950RB Parts List

Parts No.	Description	Qty.	Parts No.	Description	Qty.
A1	Main Frame	1	A12	Driving Pulley	1
OM	Owners Manual	1	A12-1	Speed Magnet	1
A1-1	Screw	6	A12-2	Nut	4
A1-2	Screw	4	A12-3	Spring Washer	4
A1-3	Servo Motor	1	A12-4	Spring Washer	4
A1-4	Axle Bearings	2	A12-5	Screw	4
A1-5	Tension Cable	1	A12-6	Speed Sensor	1
A2	Belt Tension Wheel	1	A12-7	Speed Sensor Holder	1
A3	Sensor box	1	A13	Drive Axle	1
A4	Screw	2	A14	Front Chain Cover (L)	1
A4-1	Stop Bar Tube	1	A14-1	Cover Screws	7
A4-2	Stop Bar Shaft	1	A15	Front Chain Cover (R)	1
A4-3	Stopper	1	A16	Rear Chain Cover (R)	1
A4-4	Washer	1	A17	Rear Chain Cover (L)	1
A4-5	Nut	1	A17-1	Rear Cover Screws	8
A5	Seat Rail Bracket	1	B1	Front Stabilizer Bar	1
A5-1	Bolt	4	B2	End Cap	2
A5-2	Washer	4	B3	Bolt	2
A5-3	End Cap	1	B4	Washer	2
A5-4	End Cap	1	B5	Nut	2
A5-5	Screw Cover	4	B6	Transport Wheel	2
A5-6	Screw	4	B7	Screw	2
A5-7	Washer	8	B8	Nut	2
A5-8	Seat Wheels	4	C1	Rear Stabilizer Bar	1
A5-9	Metal Bushing	4	C2	End Cap Rear	2
A5-10	Nut	4	C3	Bolt	2
A5-11	Washer	2	C4	Washer	2
A5-12	Bushing	2	C5	Nut	2
A5-13	Steel Strap	2	D	Small Handle Bar	1
A6	Aluminum Track	1	D1	End Cap	4
A6-1	Screw	4	E1	Central Support Tube	1
A6-2	Bushing	4	E1-1	Aluminum Strap	1
			E2	Decoration Cap	1
A8	Hand Pulse Wire	2	E3	Computer Wire	1
A9	Bolt	3	E4	Heart Rate Wire	1
A10	Poly V Drive Belt	1	E5	Bolt	2
A11	Magnetic Flywheel	1	E6	Washer	2
A11-2	Nut	2	F1	Right Side Handle Bar	1

## 950RB Parts List

Parts No.	Description	Qty.	Parts No.	Description	Qty.
A11-3	Bushing	2	F1-1	Handle Bar sponge	1
F1-2	Hand Pulse Sensor	1	K1	Rear End Cap	1
F2	Left Side Handle Bar	1	L1	Bottle Holder	1
F2-1	Handle Bar Sponge	1	L2	Water Bottle	1
F3	Hand Pulse Sensor	1	L3	Screw M5x18mm	2
G	Computer Console	1	M1	Left Pedal	1
G2	Screw	2	M1-1	Crank Arm Left	1
G3	Dc wire	1	M1-2	Nut	1
H1	Seat pad	1	M1-3	Bolt Cover	1
H2	Back Pad	1	M2	Right Pedal	1
J1	Screw M8x35mm	4	M2-1	Crank Arm Right	1
J2	Bolt	4	M2-2	Nut	1
J3	Washer M8	8	M2-3	Bolt Cover	1
J4	Bolt	4	N	AC Adaptor	1
J5	Washers	4	N-1	Rear AC Inlet Plug	1
K	Saddle Tube	1	P	Stop Bar	1
K2	Saddle End Cap	1	M2-3	Bolt Cover	1

### Assembly Tips

The LifeCore 950RB is made from the best materials and has been tested and received a quality control review prior to its packaging to ensure the correct parts and proper fitting of each component. This machine was designed to limit the amount of assembly needed by a customer.

Before assembly of your product, distinguish a proper and appropriate location for the unit where there is easy access to an electrical outlet with a surge protector. Unpack the box in a clear work area to allow smooth assembly. Remove all the parts from the packing material; however, do not discard packing material until assembly is complete. Double check packing materials to make sure no parts were left behind.

Note that some hardware may be preassembled to components to help with assembly and tools have been provided to assist with assembly.

### Tools Required:

- 13 mm wrench
- 15 mm wrench
- Philips Screw driver
- 6mm Allen wrench
- 5mm Allen wrench
- 4mm Allen wrench

# PARTS LIST

**A** Main frame

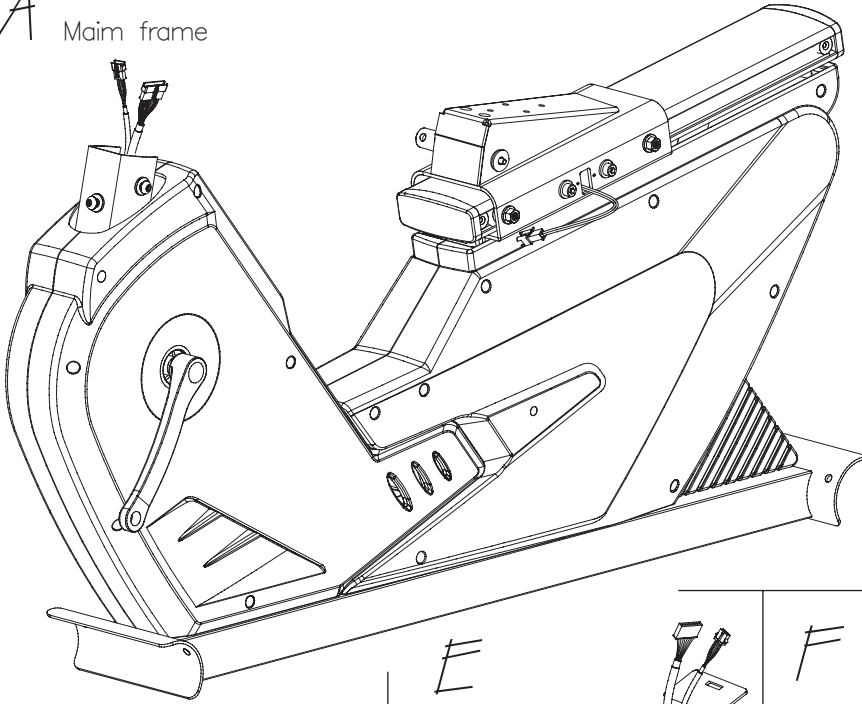

**B** Front stabilizer

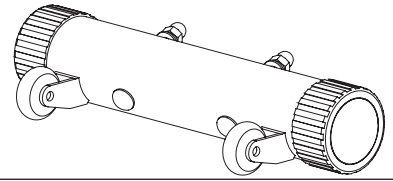

**C** Rear stabilizer

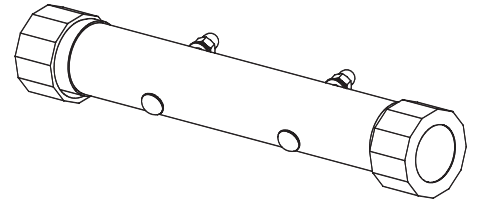

**D** Small handle bar

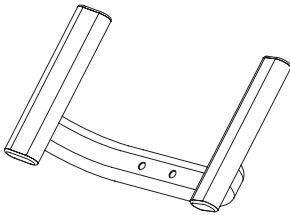

**E**  
(E1) Central support tube



(E2) Decoration cover

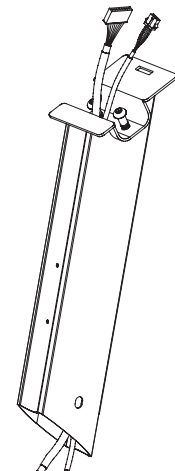

**F** Side handle bar (F1)Right

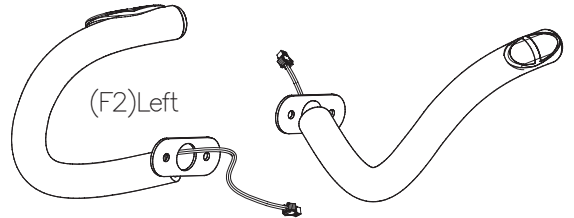

**G** Computer

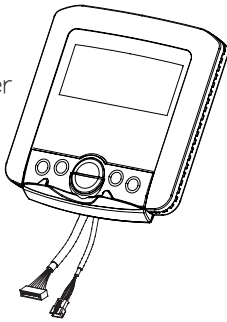

**H** Seat & Back Pad

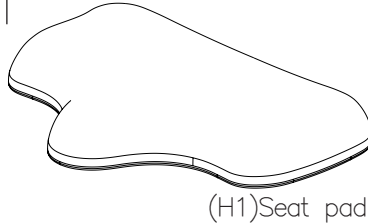

(H1)Seat pad

(H2)Back pad

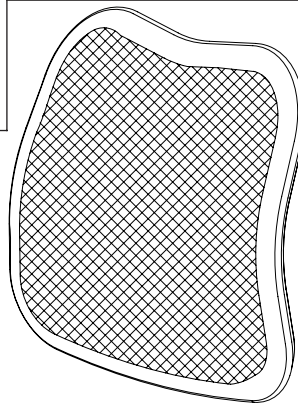

**K** Saddle Tube

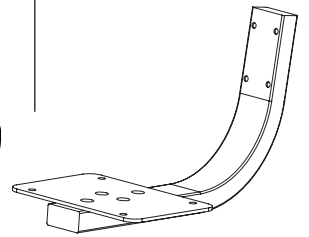

**J** (J1) Bolt M8X35mm



(J2) Bolt M8X15mm



(J3) Washer M8

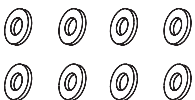

(J4) Bolt 1/4"X1-1/2"



(J5) Washer M6



**L** (L1) Bottle holder



(L2)Water bottle



(L3) Screw M5X18mm



**M** Pedal



(M1)-Left



(M2)-Right

**P** Stop Bar

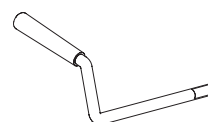

**N** Adapter

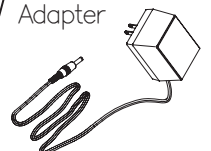



# FIGURE 1

## FIGURE 1 ASSEMBLY FOR REAR STABILIZER

Tool Needed:  
13mm wrench



The first assembly step is to attach the (C1) rear stabilizer bar with the rear part of the (A1) main frame using (C3) Bolt, (C4) Washer and (C5) Nut.

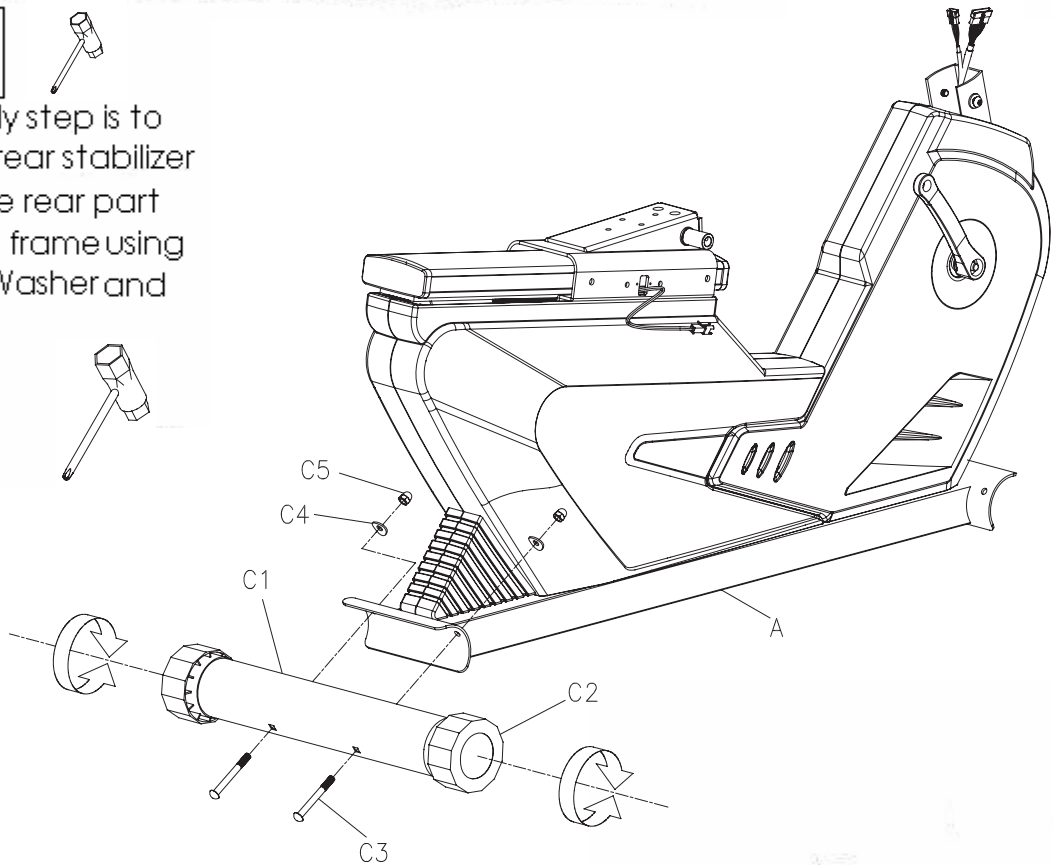

# FIGURE 2

## FIGURE 2 ASSEMBLY FOR FRONT STABILIZER

Tool Needed:  
13mm wrench



Next, attach the (B1) front stabilizer to the front of the machine using (B3) bolts, (B4) washers and (B5) nuts

Note: Once the stabilizers are attached check to see if the machine is stable, if the machine is unstable then adjust the (C2) rear end Caps to level the machine.

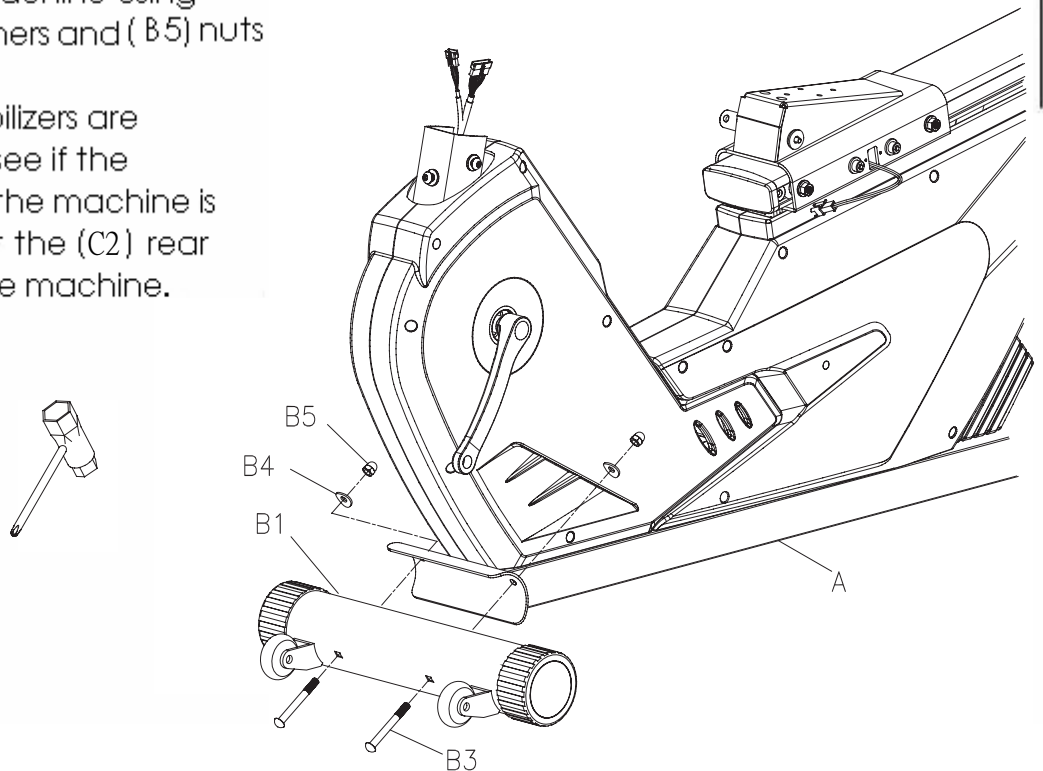
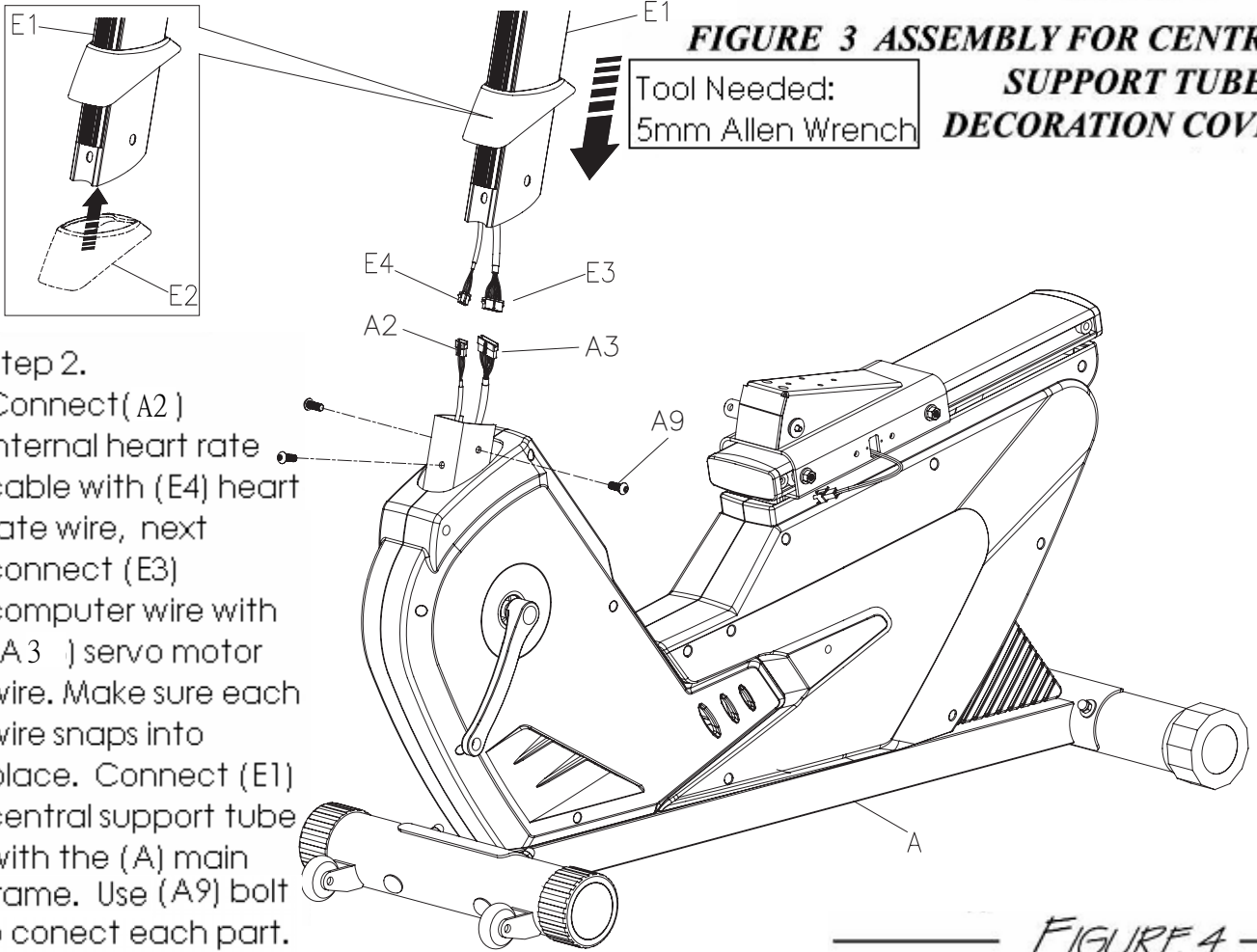

FIGURE 3

**FIGURE 3 ASSEMBLY FOR CENTRAL SUPPORT TUBE & DECORATION COVER**

Tool Needed:  
5mm Allen Wrench



Step 2.  
Connect (A2) internal heart rate cable with (E4) heart rate wire, next connect (E3) computer wire with (A3) servo motor wire. Make sure each wire snaps into place. Connect (E1) central support tube with the (A) main Frame. Use (A9) bolt to connect each part.

FIGURE 4

**FIGURE 4 ASSEMBLY FOR SMALL HANDLE BAR & WATER BOTTLE**

Tool Needed:  
6mm Allen wrench

Step 1.  
Attach (D) small handle bar using (E6) washers and (E5) bolts to (E1) central support tube.

Tool Needed:  
4mm Allen Wrench

Step 2.  
Attach (L1) bottle holder to (E1) central support tube with (L3) screws. Afterwards (L2) water bottle can be placed into (L1) bottle holder.

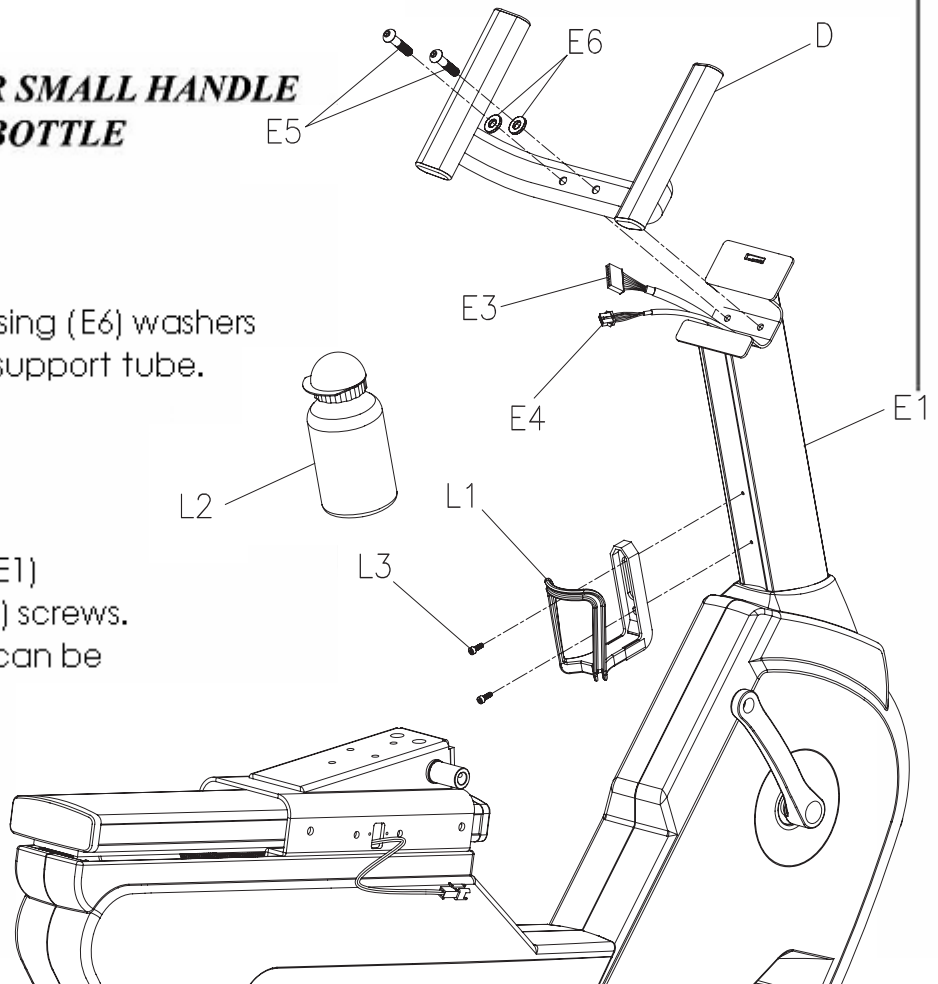



— *FIGURE 5* —

**FIGURE 5 ASSEMBLY FOR COMPUTER**

Tool Needed:  
Phillips screw driver

Note: Make Sure when the computer is being placed on the housing, that the wires are pushed back into the (E1) central support tube to prevent pinching a wire when the computer is being locked into place.

Step 1. Remove (G2) screws from the back of the console bottom housing.

Step 2. Connect (E3) computer wire and (E4) heart rate wire to (G) computer console.

Step 3. Slide (G) computer console onto (E1) central support tube. Using (G2) screws, fasten screws to back of computer bracket.

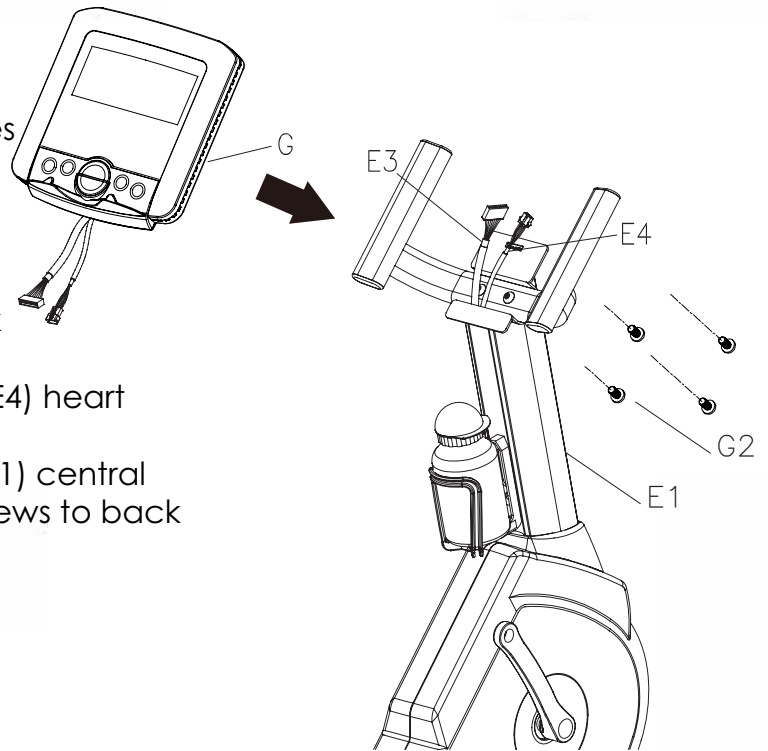

— *FIGURE 6* —

**FIGURE 6 ASSEMBLY FOR SADDLE TUBE & BACK PAD**

Tool Needed:  
6mm Allen wrench  
5mm Allen wrench

Step 1.

Connect (K) saddle tube to (A5) sliding tracking using (J3) washers and (J1) Bolts.

Step 2.

Fit (H2) back pad to (K) saddle tube with (J5) washer and (J4) Bolts.

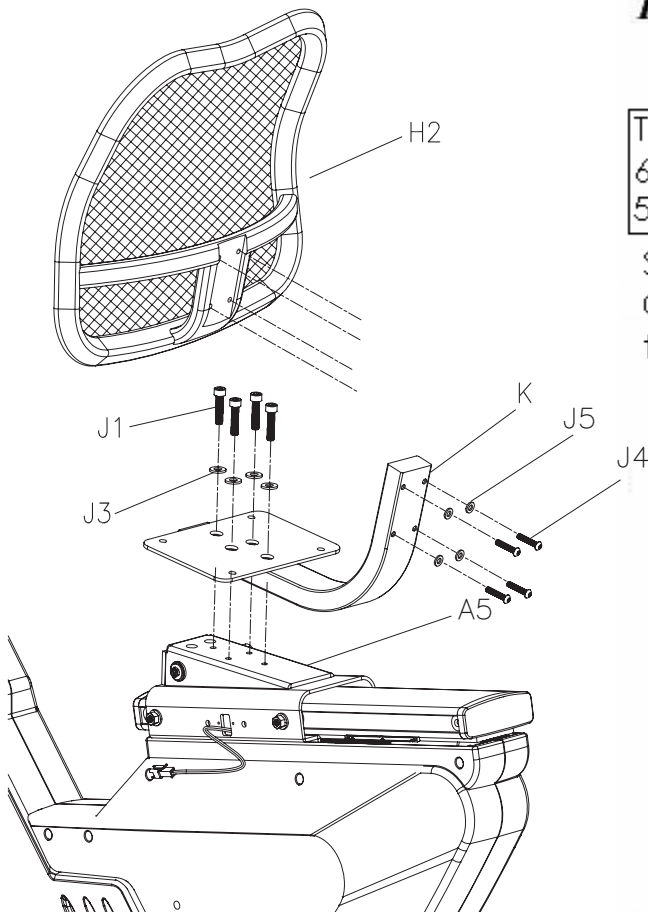

FIGURE 7

**FIGURE 7 ASSEMBLY FOR STOP BAR & RIGHT SIDE HANDLE BAR**

Tools Needed:  
4mm Allen wrench  
6mm Allen wrench

Step 1.  
Insert (P) stop bar to the (A4-1) stop bar tube and tighten (A4) screws to secure stop bar.

Step 2.  
Connect (A8) hand pulse wire to (F3) hand pulse sensor wire which is coming out of (F1) right side handle bar. When tightening (A5-1) bolt and (A5-2) washer, make sure that the hand pulse wires do not get pinched.

Be careful to not pinch hand pulse wire when tightening.

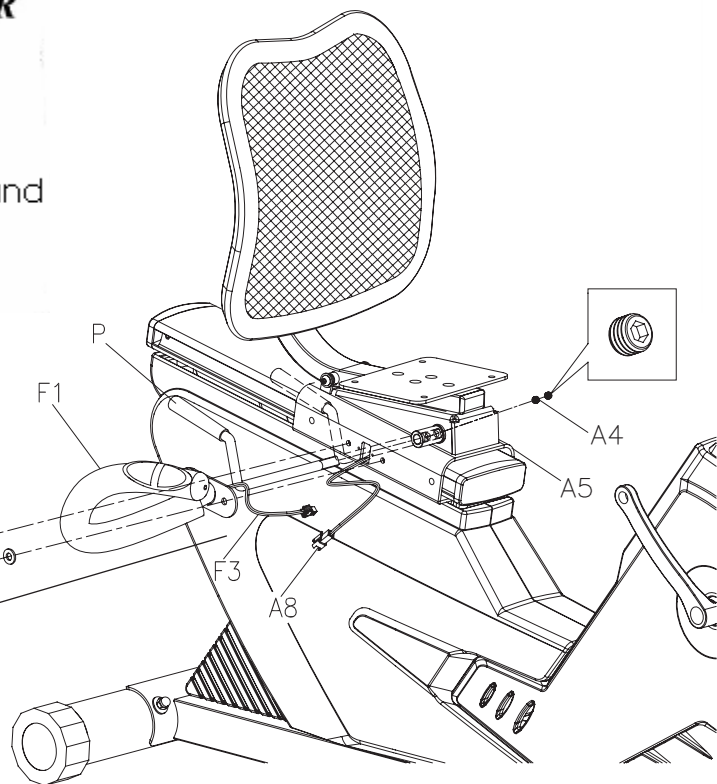
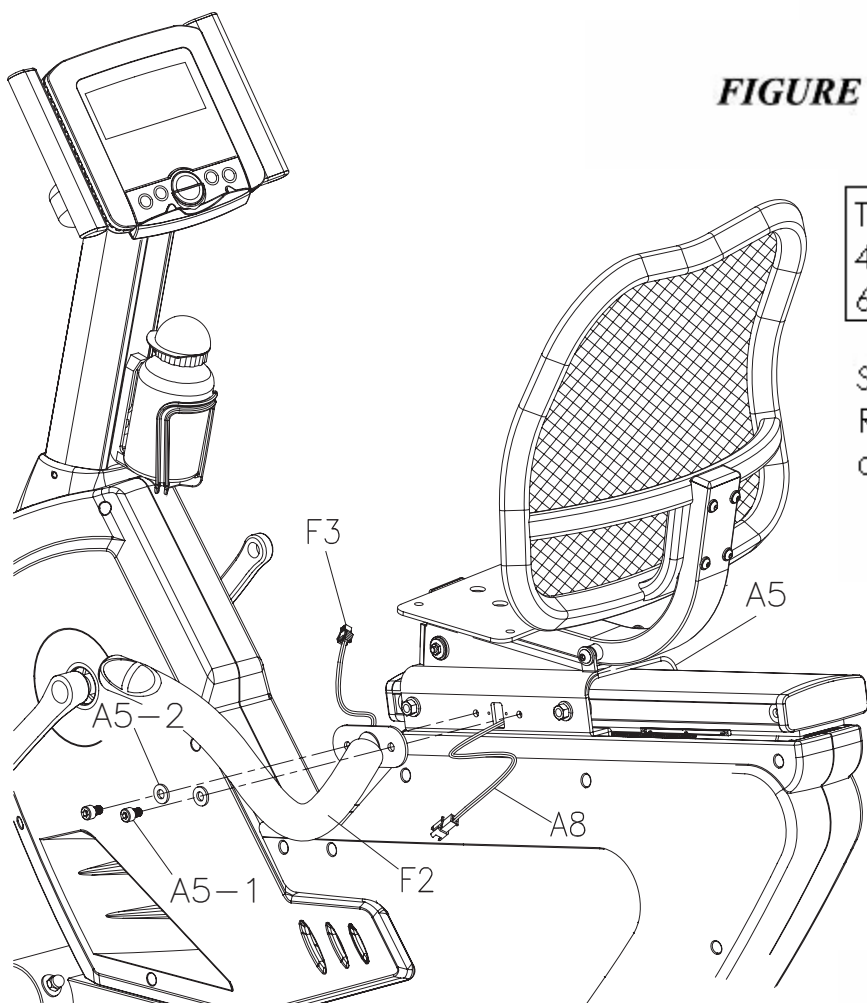

FIGURE 8  
**FIGURE 8 ASSEMBLY FOR LEFT SIDE HANDLE BAR**

Tools Needed:  
4mm Allen wrench  
6mm Allen wrench

Step 1.  
Repeat same assembly instructions as right side.



## FIGURE 9

### FIGURE 9 ASSEMBLY FOR SEAT PAD & MAIN FRAME

Tool Needed:  
6mm Allen wrench

Step 1.  
Install (H1) seat pad to (K) saddle tube  
using (J3) washer and (J2) bolt.

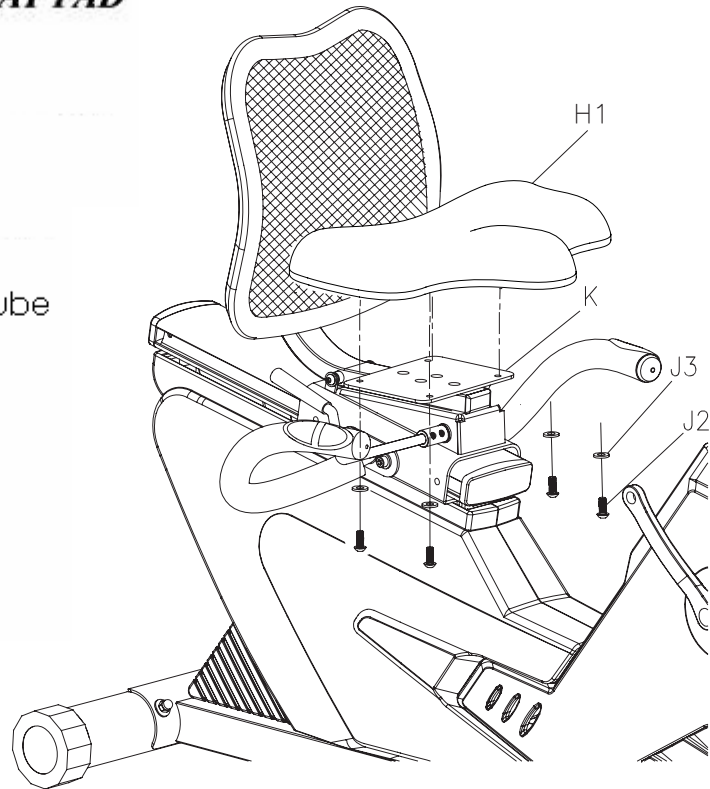

## FIGURE 10

### FIGURE 10 ASSEMBLY RIGHT & LEFT PEDAL

Tool Needed:  
15mm wrench

Step 1.  
Attach the right pedal (M2) to the  
right crank arm. Tighten the right pedal  
treads into the crank clockwise.

Step 2.  
Attach the left pedal (M1) to left crank arm.  
Tighten the left pedal  
treads into the crank counter-  
clockwise.

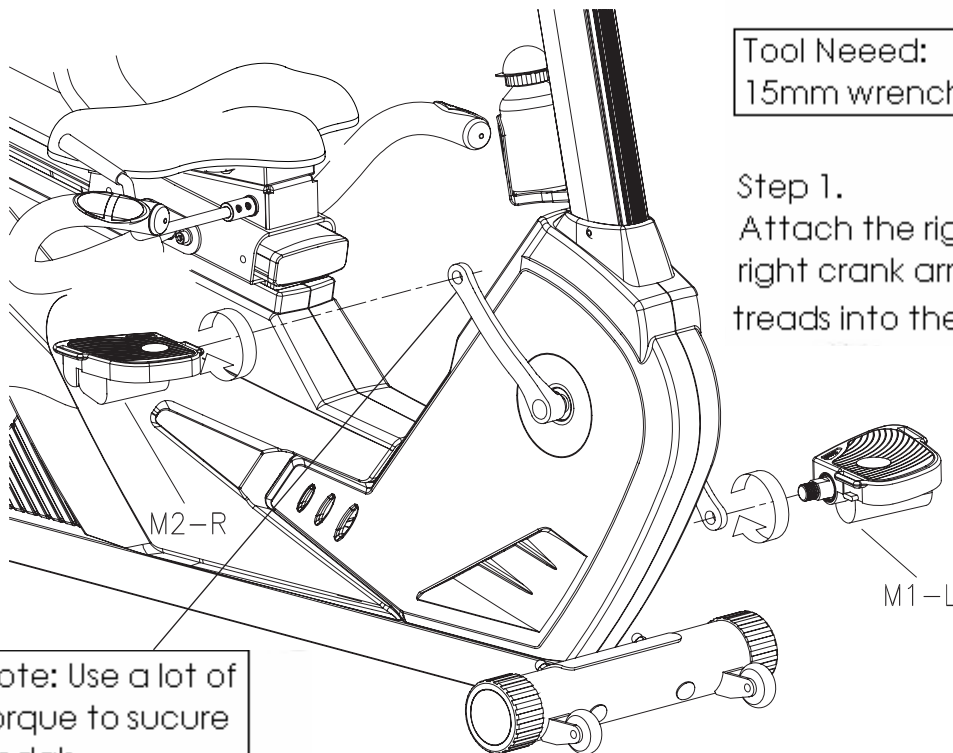

Note: Use a lot of  
torque to secure  
pedals.

## Recumbent Seat Adjustments

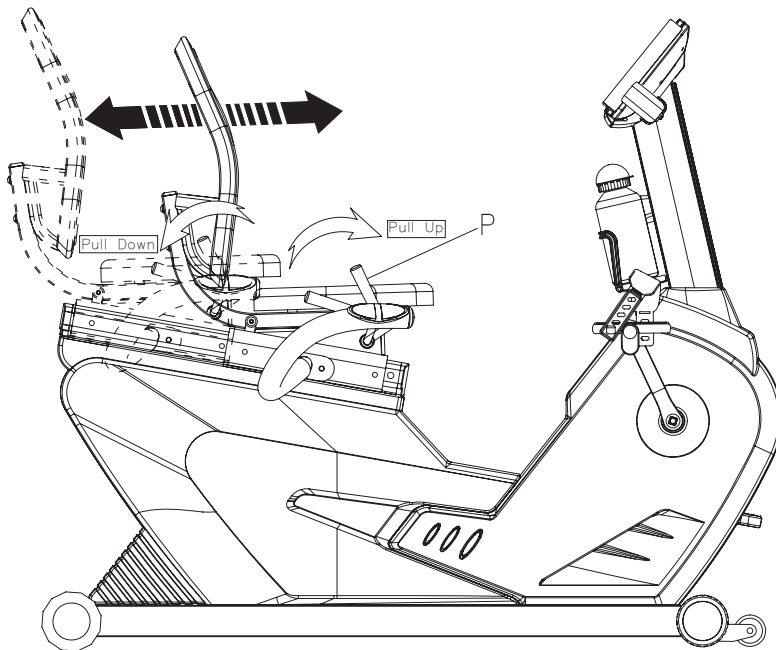

### How to adjust the Seat Pad

To adjust the seat rail according to a user's height, pull up on the stop bar (P) and set the seat to the most comfortable location which allows the rider to have a smooth and comfortable motion. The proper way to cycle is to have the knees slightly bent during the furthest pedal rotation.

## How to transport the bike

If the machine needs to be transported to a different location, stand at the front of the machine and push down on the front handle bars until the weight of the machine is transferred to the transport wheels and the rear of the machine is in the air. You can now easily move the machine to a new location. Gently set the machine down at its new location.

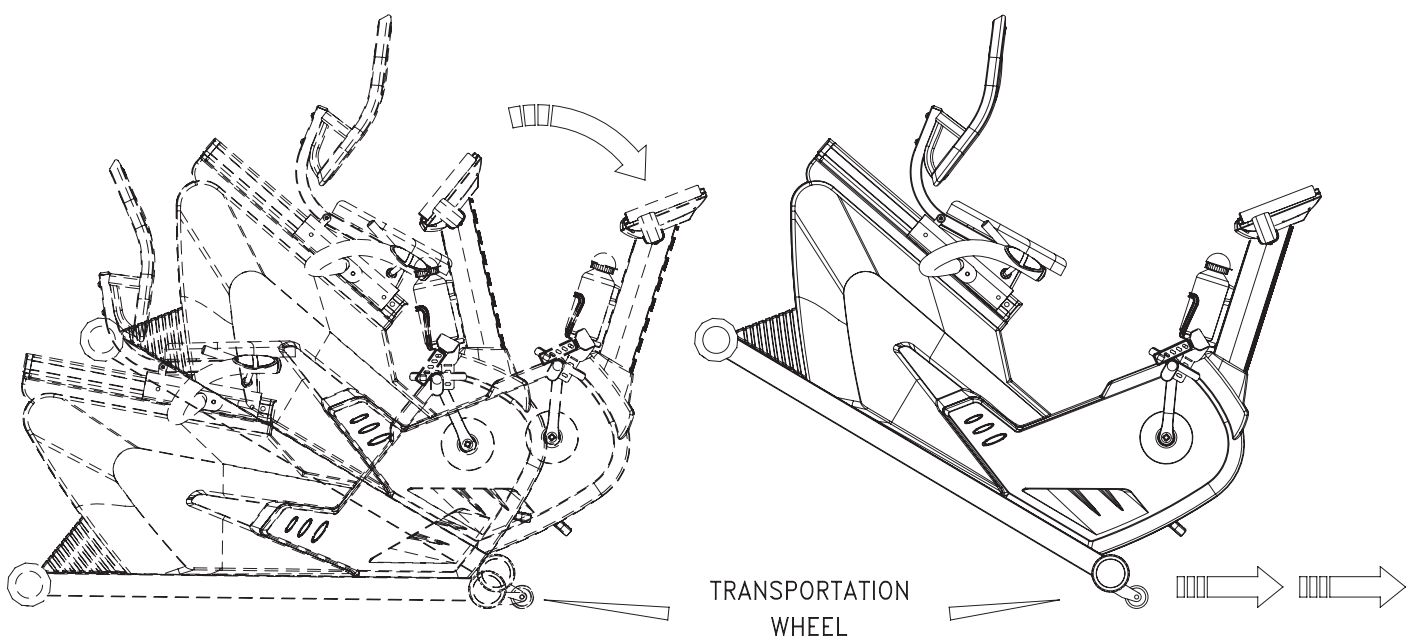

## How to power your machine

It is always recommended that the unit's AC adaptor be plugged into a surge protector or unplugged after every use to prevent electrical damage.

The machine has an electrical inlet at the rear, where the unit can run on an AC adaptor. It is recommended that this adaptor be plugged into a surge protector, which is not shown below. AC Adaptor specification AC Adapter US standard with maximum wattage 4.5W - I/P: 120V AC 60HZ - O/P: (DC6V 1000MA)

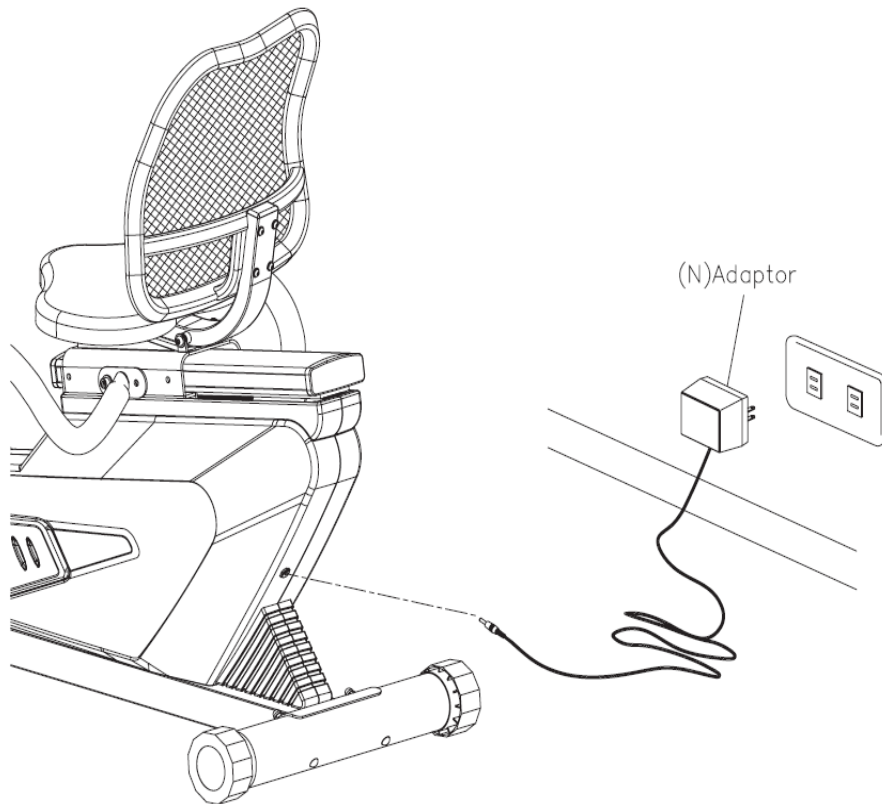



## 1. FUNCTION IDENTIFICATION

### BAR GRAPH DISPLAY

Profiles Programs as listed here  
 16 x Rows = 16 Load resistance  
 Levels  
 16x Column = time intervals

### 12 Program Profiles Graph Key

Quick key of press 12 Program  
 Profiles by pressing panel.

### FUNCTION DISPLAY

During your workout you can select  
 what is shown in the Mode BAR  
 Display.

The flashing text indicates what is  
 being shown in the Mode Display.

### START / STOP Key

START & STOP KEY.



### MODE CONTROL LIST

MANUAL-PROGRAM - WATT  
 -PERSONAL-H.R.C.

### USER DATA Display

There are total 5 user Data  
 (.U0-U4) including Gender, Age,  
 H.t. ( Height) and W.t. ( Weight)

### MODE Key

Confirm your selection.

### RESET Key

Reset default function value..

### UP (+) and DOWN (-) Key

Adjust function value by  
 pressing two keys.

### RECOVERY Key

The RECOVERY PROGRAM  
 automatically evaluate your  
 Fitness Level.

## 2. MODEL FUNCTION DESCRIPTION

TIME	: 0:00~99:59.
SPD	: 0.0~99.9 KMH
RPM	: 0~15~999
WATT DISPLAY	: 0~999
DISTANCE	: 0.00~99.99 KM.
CALORIES	: 0~9999.
TEMPERATURE	: 0~60°C / 32~99°F
GENDOR	: GIRL / BOY
AGE	: 10-25-99
HEIGHT	: 100-160-200 (CM) / 40-60-80 (INCH)
WEIGHT	: 20-50-150 (KG) / 40-100-350 (LB)
PULSE	: P~30~240
HEART SYMBOL	: ON/OFF blinks
MANUAL	: 1~16 levels
PROGRAMM	: P1~P12
WATT CONSTANT:	10~350 WATTS
PERSONAL	: U1~U4
H.R.C	: 55%、75%、90%、IND (TARGET)
USER DATA	: U0 ~U4 (U1 ~ U4 memorized user data)

### 3. POWER ON

1. Plug in 6V 1A power Adaptor to right country socket and connect the I / L PIN to Fitness equipment.
2. When stay in U0~U4, only there is pulse input, then PULSE symbol on the right in window will operate to display automatically as per H.R.C.: If pulse maximum value is set, then the function cancel automatically.
3. Recovery : To test user's heart recovery extent in fixed time, time will be 1 minute.
4. User Data : 5 groups for user setting U0~U4, every user can set gender、age、height and weight, however when power off or TOTAL RESET,U0 setting files will be cleaned and reset and U1-U4 setting values will be saved permanently.
5. USER SETTING VALUE MEMORY: setting files memory (TIME、DISTANCE、CALORIES、PULSE setting value)&the function setting value(set value which used last time or changed manual load set value: or PROGRAM PX(1-12)...Etc. it can only remember one of them. For instance: WATT CONSTANT SET VALUE: or PERSONAL program), U1~U4 fours groups altogether.

### 4. CONTROL MODE DESCRIPTION

- A. MANUAL Set the resistance level by using the dot matrix display then (if required) to set function value. TIME/DISTANCE / CALORIES / PULSE; the function value will be counting down from pre-setting number to 0. And then press ST/STOP to START manual program at anytime to start your workout.
- B. PROGRAM 12 automatic adjusting programs with control exercise program profiles (P1~P12), Resistance level can be adjusted by knobbing ENTER (UP/DOWN) during the program.

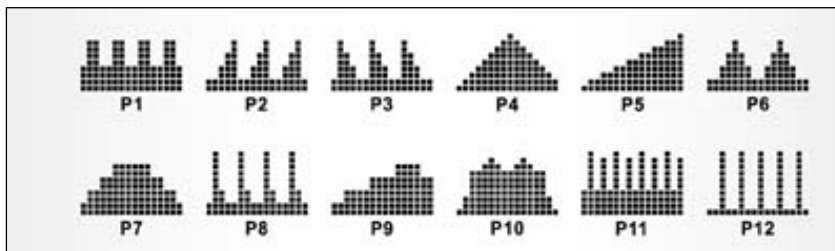

#### C. WATTS CONSTANT

User can default WATTS value at his/her desire 10-350 watts between 10~350 watts by using the UP / DOWN knob. To fix WATTS constant value and then press ST/STOP key. Use WATTS control mode to train yourself in different WATTS's constant.

#### D. PERSONAL

Create your own Program profile through U1~U4 by setting the resistance level for each individual segment. Then the Program will be automatically saved for future use. U0 ENTER can be set the same as U1~U4 but this Program cannot be saved.

#### E. H.R.C

HEART RATE CONTROL- Select your own target Heart Rate by choosing from one of the preset programs 55%, 75%, or 90%. Please ENTER your age into the User Data to ensure that your target heart rate is set correctly. The PULSE display will flash when you have reached your target heart rate according to the Program you have chosen.

- i. 55% -- DIET PROGRAM
- ii. 75% -- HEALTH PROGRAM
- iii. 90% -- SPORTS PROGRAM
- iv. TARGET—USER SET TARGET HEART RATE

#### F. RECOVERY

When you have finished your workout, press RECOVERY. For RECOVERY to function correctly, it needs your Heart Rate input. TIME will count down from 1 minute and then your fitness level from F1 to F6 will be displayed.

NOTE: during RECOVERY, no other displays will operate.

**F 1 ~ F6 = RECOVERY HEART RATE LEVEL**

Operating ENTERS:

1. User press H.R.C key to start the H.R.C.
2. Get the result from F1 - F6.

Condition	Score	Heart Rate
<b>Excellent</b>	F1	Above 50
<b>Good</b>	F2	40 ~ 49
<b>Average</b>	F3	30 ~ 39
<b>Fair</b>	F4	20 ~ 29
<b>Poor</b>	F5	10 ~ 19
<b>Very Poor</b>	F6	Under 10

G. USER DATA :

U0~U4 are user's Personal Programs (refer Personal). Users should ENTER their gender, age, height and weight. Only data for U1 to U4 will be saved. U0 is for casual users.

#### 7 BUILT-IN Heart Rate Receiver with chest Belt

The computer with built-in Heart Rate receiver , the user can put on chest belt to detect the Heart Rate beat.; How to put on chest belt, please refer Chest Belt user manual.

#### TIPS

1. Option: Plug in AC Adaptor (**6 VOLT, 1 A**).
2. Keep moisture away from computer.

## Warranty Card – LifeCore Fitness Inc.

### LC-950RB Recumbent Bike

This Limited Warranty applies in the United States to products manufactured or distributed by LifeCore Fitness, Inc. under the LifeCore brand name. The warranty period for the original purchaser is (lifetime) on the frame against defects in materials and workmanship under normal use and conditions (excluding expendable parts such as paint & finish). Home 5 years parts, 1 year labor, light commercial 2 years parts 90 days labor warranty against manufacturer defects. This warranty does not cover wear and tear items such as, but not limited to, transportation wheels, foot pedals, rubber grips, plastic end caps, scratched parts, broken covers, and cosmetic damage. Wear items pertain to components that might need to be replaced due to normal wear and tear as a result of normal usage. Labor warranty does not cover improper installation, alterations and/or modifications, misuse, abuse, accident, improper maintenance, noises such as: squeaks, clunks, thumps from a result of poor or lack thereof preventive maintenance. LifeCore warrants that the product you have purchased for personal, family household use from LifeCore, or from an authorized LifeCore reseller, is free from defects in materials or workmanship under normal use during the warranty period. In order to validate the warranty this product must have been registered through LifeCore Fitness Inc., and/or a copy of the proof of purchase, and serial number must be presented at time of service. If these items are not presented at the time of requesting parts or service LifeCore Fitness Inc. will not cover any warranty set forth. During the warranty period LifeCore will at no additional charge, repair or replace (at LifeCore option) the part or product if it becomes defective, malfunctions, or otherwise fails to conform with this Limited Warranty under normal personal use as determined by a LifeCore technician. Any labor cost above the amount allocated by LifeCore is the responsibility of the original purchaser. If a product is shipped, delivered or transported to an area that is not a LifeCore Fitness Inc.'s distribution area or is out of a serviceable area, it is the purchaser's sole responsibility to find service and pay for any fees associated with servicing of a product out of LifeCore Fitness distribution or serviceable area. To obtain warranty service, you must contact the original place of purchase. In repairing the product, LifeCore may replace defective parts, or at the option of LifeCore, serviceable used parts that are equivalent to the new parts in performance. All exchanged parts and products replaced under this warranty will become the property of LifeCore. LifeCore reserves the right to change manufacturers of any parts to cover any existing warranty. Any parts determined to be defective must be returned to LifeCore to obtain warranty service. You must prepay any shipping charges, export taxes, custom duties and taxes, or any other charges associated with transportation of the parts or product. In addition, you are responsible for insuring any parts or product shipped or returned. You assume the risk of loss during shipment. Any evidence of alteration, erasing or forgery of proof-of-purchase documents will be cause to void this Limited Warranty. This warranty does not extend to any product not purchased from LifeCore or from an authorized LifeCore reseller. This Limited Warranty does not extend to any product that has been damaged or rendered defective; (a) as a result of accident, misuse, or abuse; (b) by the use of parts not manufactured or sold by LifeCore; (c) by modification of the Product or normal wear and tear; (d) operation on incorrect power supplies; or (e) as a result of service by anyone other than LifeCore, or an authorized LifeCore service provider. Product on which the serial number has been defaced or removed is not eligible for warranty service. Should any Product be submitted for warranty service be found ineligible, an estimate of repair cost will be furnished and the repair will be made if requested by you upon receipt of payment or acceptable arrangements for payment. LIFECORE MAKES NO OTHER WARRANTIES, EXPRESSED OR IMPLIED, INCLUDING ANY IMPLIED WARRANTIES OR MERCHANTABILITY AND FITNESS FOR A PARTICULAR PURPOSE. LIFECORE EXPRESSLY DISCLAIMS ALL WARRANTIES NOT STATED IN THIS LIMITED WARRANTY. NEITHER LIFECORE NOR ANY OF ITS AFFILIATES SHALL BE RESPONSIBLE FOR INCIDENTAL OR CONSEQUENTIAL DAMAGES. PLEASE SEND IN THE ATTACHED WARRANTY CARD WITHIN (10) DAYS OF PURCHASE TO REGISTER YOUR PRODUCT WITH LIFECORE FITNESS. THANK YOU FOR YOUR BUSINESS! PLEASE MAIL WARRANTY CARD TO: LIFECORE FITNESS, INC, 2575 Pioneer Ave. Suite 101. Vista, CA 92081. Phone (760)599-4555, Fax (760) 946-7602 or register online at lifecorefitness.com, Customer Service: 888-815-5559

---

### LC-950RB Recumbent Bike

### Please Attach a Copy of the Original Receipt

Full Name: \_\_\_\_\_

Address: \_\_\_\_\_

City: \_\_\_\_\_ State: \_\_\_\_\_ Zip Code: \_\_\_\_\_

Daytime Phone No.: \_\_\_\_\_ Cell Phone No.: \_\_\_\_\_

Email: \_\_\_\_\_

Dealer Purchased from: \_\_\_\_\_

Model: LC-950RB Bike \_\_\_\_\_ Date Of Purchase: \_\_\_\_\_

Serial No. \_\_\_\_\_

Environment Placed:  Residential  Light Commercial  Commercial