

Focus II manual

Light grid/Light curtain
Focus II type 4
Focus II type 2



≡ JOKAB SAFETY ≡

A MEMBER OF THE ABB GROUP

www.jokabsafety.com

Read and understand this document.

Please read and understand this document before using the products. Please consult your JOKAB SAFETY representative if you have any questions or comments.

WARRANTY

JOKAB SAFETY's exclusive warranty is that the products are free from defects in materials and workmanship for a period of one year (or other period if specified) from date of sale by JOKAB SAFETY.

JOKAB SAFETY MAKES NO WARRANTY OR REPRESENTATION, EXPRESS OR IMPLIED, REGARDING NON-INFRINGEMENT, MERCHANTABILITY, OR FITNESS FOR PARTICULAR PURPOSE OF THE PRODUCTS, ANY BUYER OR USER ACKNOWLEDGES THAT THE BUYER OR USER ALONE HAS DETERMINED THAT THE PRODUCTS WILL SUITABLY MEET THE REQUIREMENTS OR THEIR INTENDED USE. JOKAB SAFETY DISCLAIMS ALL OTHER WARRANTIES, EXPRESS OR IMPLIED.

LIMITATIONS OF LIABILITY

JOKAB SAFETY SHALL NOT BE RESPONSIBLE FOR SPECIAL, INDIRECT, OR CONSEQUENTIAL DAMAGES, LOSS OF PROFITS OR COMMERCIAL LOSS IN ANY WAY CONNECTED WITH THE PRODUCTS, WHETHER SUCH CLAIM IS BASED ON CONTRACT, WARRANTY, NEGLIGENCE, OR STRICT LIABILITY.

In no event shall responsibility of JOKAB SAFETY for any act exceed the individual price of the product on which liability asserted.

IN NO EVENT SHALL JOKAB SAFETY BE RESPONSIBLE FOR WARRANTY, REPAIR, OR OTHER CLAIMS REGARDING THE PRODUCTS UNLESS JOKAB SAFETY'S ANALYSIS CONFIRMS THAT THE PRODUCTS WERE PROPERLY HANDLED, STORED, INSTALLED, AND MAINTAINED AND NOT SUBJECT TO ABUSE, MISUSE, OR INAPPROPRIATE MODIFICATION OR REPAIR.

SUITABILITY FOR USE

JOKAB SAFETY shall not be responsible for conformity with any standards, codes, or regulations that apply to the combination of products in the customer's application or use of the product.

At the customer's request, JOKAB SAFETY will provide applicable third party certification documents identifying ratings and limitations of use that apply to the products. This information by itself is not sufficient for a complete determination of the suitability of the products in combination with the end product, machine, system, or other application or use.

The following are some examples of applications for which particular attention must be given. This is not intended to be an exhaustive list of all possible uses of the products, nor is it intended to imply that the uses listed may be suitable for the products:

Outdoor use, uses involving potential chemical contamination or electrical interference, or conditions or uses not described in this document.

Nuclear energy control systems, combustion systems, railroad systems, aviation systems, medical equipment, amusement machines, vehicles, and installations subject to separate industry or government regulations.

Systems, machines, and equipment that could present a risk to life or property.

Please know and observe all prohibitions of use applicable to the products.

NEVER USE THE PRODUCTS FOR AN APPLICATION INVOLVING SERIOUS RISK TO LIFE OR PROPERTY WITHOUT ENSURING THAT THE SYSTEM AS A WHOLE HAS BEEN DESIGNED TO ADDRESS THE RISKS, AND THAT THE JOKAB SAFETY PRODUCT IS PROPERLY RATED AND INSTALLED FOR THE INTENDED USE WITHIN THE OVERALL EQUIPMENT OR SYSTEM.

PERFORMANCE DATA

While every effort has been taken to ensure the accuracy of the information contained in this manual JOKAB SAFETY cannot accept responsibility for errors or omissions and reserves the right to make changes and improvements without notice. Performance data given in this document is provided as a guide for the user in determining suitability and does not constitute a warranty. It may represent the result of JOKAB SAFETY'S test conditions, and the users must correlate it to actual application requirements. Actual performance is subject to the JOKAB SAFETY Warranty and Limitations of Liability.

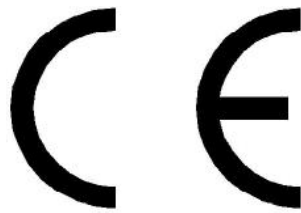

The Focus II Safety barrier complies with CE provisions according to the following directives:

Machinery Directive	2006/42/EC
EMC Directive	89/336/EEC
EU standards	EN ISO 13849-1:2008
	EN 61496-1:2004
	IEC 61496-2:2006

The barrier is certified by:

TÜV to safety standard EN 61496-1/2 Type 2/4
CSA to safety standard CAN/CSA C22.2
No 1010.1-92 and UL 61010C-1

MANUFACTURER: JOKAB SAFETY AB
Boplatsgatan 3
213 76 Malmö
SWEDEN
Phone +46 (0)40 6715600
FAX +46 (0)40 6715601
E-Mail info@jokabsafety.com

USER'S MANUAL: Original manual
Version 2.02 dated 2011-02-02

Table of contents

1	System Overview and Applications:	6
1.1	General Data.	7
1.2	Maintenance.	7
1.3	Important information.	8
2	Function and Possibilities (Short Description).	9
3	Mechanical Installation.	10
3.1	Mechanical Assembly.	10
3.2	Alignment Procedure.	12
3.3	Calculation of Minimum Distance for Installation.	12
3.4	Distance to Reflecting Surfaces.	14
4	Electrical Installation.	15
4.1	Important Notes on Installation.	15
4.2	Connection of Cable C5, C8 in M12 C01-C04 Connectors.	16
4.3	Setting up of Internal Change-Over Switches Transmitter.	17
4.4	Setting up of Internal Change-Over Switches Receiver.	18
4.5	Setting up Scan Codes.	19
4.6	Choice of Reset Procedure.	20
5	Connection Examples.	21
5.1	Connection Example, Basic with and without muting.	21
5.2	Connection Example, for connection to safety relay.	21
5.3	Connection Example, muting unit to safety relay.	22
5.4	Connection Example, Vital / Pluto with Tina units.	23
5.5	Connection Example, Pluto.	23
5.6	Connection Example, for connection of Code B.	23
5.7	Specifications for Available Variants.	24
5.8	Dimensional Drawing.	26
5.9	Label description	26
6	Muting.	27
6.1	Muting, Installation.	27
6.2	Muting, Modes.	27
6.3	T-Activation Mode.	28
6.4	L-Activation Mode.	29
6.5	X-Activation Mode.	30
6.6	Partial Muting.	31
7	Override.	32

8	Pre-reset function.	33
9	Blanking.	34
	9.1 Programming of Blanking.	35
10	Single/Double Break function.	36
	10.1 Single Break function.	37
	10.2 Double Break function.	37
11	CUT - the devided light curtain.	38
12	External Device Monitoring (EDM).	39
13	Checkout Procedure.	39
14	Transmitter LED Information.	40
15	Receiver LED Information.	41
16	Regular checkout and test.	43
17	Technical specifications.	44
18	Accessories, cables.	46
19	Spare parts.	47
20	WET enclosure.	47
21	Bjorn - stands.	48
22	Dimensions of brackets and profile.	50
23	Dimensions of MFII mirrors and bracket.	51
24	Variant list and general schedule.	52
25	Checkout procedure log.	54
26	Test procedure log.	55

1 System Overview and Applications:

Summary - Focus light curtain/grid, Type 2 (FII-2-) and 4 (FII-4-)

Type (x) x=2 or 4	FII-x-14-zzzz	FII-x-30-zzzz	FII-x-K4-zzzz	FII-x-K3-800	FII-x-K2-500	FII-x-K4-zzzz D	FII-x-K3-800 D	FII-x-K2-500 D	FII-x-K2C-zzzz	FII-x-K2C-800	FII-x-K1C-500
Resolution	14	30	300 400	400	500	300 400	400	500	300 400	800	500
Height (mm=zzzz) See 5.7	150 300 450 600 750 900 1050 1200 1350 1500 1650 1800 1950 2100 2250 2400	150 300 450 600 750 900 1050 1200 1350 1500 1650 1800 1950 2100 2250 2400	900 1200	800	500	900 1200	800	500	900 1200	800	500
Range (m) SR LR	0,2-3 3-6	0,2-7 7-14	0,5-20 20-40	0,5-20 20-40	0,5-20 20-40	0,5-20 20-40	0,5-20 20-40	0,5-20 20-40	0,5-7 1200	0,5-8	0,5-12
Reaction time off (ms)	See 5.7	See 5.7	13	13	13	13	13	13	13	13	13
Reaction time on (ms)	See 5.7	See 5.7	142	142	142	142	142	142	142	142	142
Manual reset	•	•	•	•	•	•	•	•	•	•	•
Automatic reset	•	•	•	•	•	•	•	•	•	•	•
Pre reset	•	•	•	•	•	•	•	•	•	•	•
Muting inputs	•	•	•	•	•	•	•	•	•	•	•
Muting lamp supervision	•	•	•	•	•	•	•	•	•	•	•
Override	•	•	•	•	•	•	•	•	•	•	•
Muting T / L / X	•/•/•	•/•/•	•/•/•	•/•/•	•/•/•	•/•/•	•/•/•	•/•/•	•/•/•	•/•/•	•/•/•
Blanking 3 types	•/•/•	•/•/•	-/-/-	-/-/-	-/-/-	-/-/-	-/-/-	-/-/-	-/-/-	-/-/-	-/-/-
Single / Double break	•/•	•/•	-/-	-/-	-/-	-/-	-/-	-/-	-/-	-/-	-/-
EDM	•	•	•	•	•	•	•	•	•	•	•
Dyn. Adaption to Vital / Pluto	✘	✘	✘	✘	✘	✘	✘	✘	✘	✘	✘

- Standard
 - ✘ With Tina 10A / 10B / 10C or FMC-Tina
- Note!**
For ordering data and article number see 5.7.
For more information see our home page.

1.1 General Data.

Focus II light grids and curtains are active optoelectronic protective devices, AOPD, of type 2 and 4 by IEC 61496-1 and EN 61496-2. They are intended to be used where it is essential to safeguard operators of dangerous machinery, robots, or other automated systems where access to hazardous parts may be gained.

Before using the Focus units, all personnel responsible for installation and maintenance of this equipment must ensure that they have read and understood the information contained in this manual. It is essential that units are installed and used according to the instructions in this manual. All relevant standards and regulations regarding the use of this type of equipment must also be strictly adhered to.

1.2 Maintenance.

With the exception of checking alignment and cleaning the polycarbonate front covers that protects the optics, no part of the safety barrier needs to be maintained or can be repaired by the user. The installation, however, should regularly be checked and the results recorded. Should there be any errors, the barriers must be sent to our service location together with an error description as well as estimated operating time.

Note! Damage or dirt on the cover does not compromise the safety level of the barriers but may cause operational disturbance. Do not use woollen cloth, solvent or any other material when cleaning, which may scratch or in some way damage the surface of the cover. Operational conditions decide how often the cover needs to be cleaned.

JOKAB SAFETY AB does not accept any liability for damage or injury due to incorrect use of the protection barriers or associated components.

1.3 Important information.

The Focus II system must be installed, configured, and incorporated into a machine control system by a sufficiently trained and qualified person.

An unqualified person may not be able to perform these operations properly, which may cause a person to go undetected, resulting in serious injury.

When changes are made to each function using the selector switches, the administrator must manage the detail of the changes and perform the changes. Accidental functional setting change may cause failure of human body detection, resulting in a serious injury.

Do not drop the products. Dropping the products may lead to internal or external damage. Please return a Focus II system that was dropped on the floor to your JOKAB SAFETY service for inspection or repair. Failure to do so may result in serious injury.

Make sure to test the operation of the Focus II system after installation to verify that the Focus II system operates as intended. Make sure to stop the machine until the test is complete. Unintended function settings may cause a person to go undetected, resulting in serious injury.

Install the interlock switch in a location that provides a clear view of the entire hazardous area and where it cannot be activated from within the hazardous area.

The Focus II system cannot protect a person from a projectile exiting the hazardous zone. Install protective cover(s) or fence(s).

A sufficiently trained and qualified person must properly configure muting related timings for its specific application, and that person must have responsibility for settings, especially when the muting time limit is infinite.

Install the switch that activates the override in a location that provides a clear view of the entire hazardous area and where it cannot be activated from within the hazardous area. Make sure that nobody is in the hazardous area before activating the override function.

Do not place fluorescent and/or incandescent lights within the effective aperture angle of the receiver, as it may influence the Focus II system under certain circumstances. Install the sensor system so that it is not affected by any reflective surfaces. Failure to do so may hinder detection, resulting in serious injury. When using more than 1 set of Focus II system, install them so that mutual interference does not occur, such as by configuring series connections or using physical barriers between adjacent sets.

2 Function and Possibilities (Short Description).

A beam of infra-red light is generated between transmitter and receiver. If anyone should interrupt this beam, the OSSD outputs of the safety barriers (see 5.1) are opened, and dangerous machinery is interrupted.

Safety barriers come in heights between 150 mm and 2400 mm and the reaction time is between 13 ms and 103 ms, depending on the model.

Electric connection is made via an M12 connector. Steering and control of beams that are transmitted and received is made by two microprocessors, which also transmit all information on status and alignment of the barrier via four LED's in the transmitter and five in the receiver (see 14,15).

Focus contains many good and user-friendly functions. Below is a summary with references to the respective chapters that contain more information.

Muting (see 6) means that one or more segments, or the whole barrier, may be bypassed when material is passed through it. If a light grid is used, one or more beams, or the whole grid, may be bypassed.

Override (see 7) is a function which makes it possible to bypass the light barrier and activate the OSSD outputs if machine start is necessary, when if one or more beams are interrupted.

Note: Muting and override demands a connected LMS indicator (resistor 220Ω,3W) before power is switched on.

Blanking (floating or fixed) (see 9) makes it possible for the beams to be constantly interrupted in the protection area. With floating blanking, the object can move in the protection area without triggering the safety function. Other beams are active with normal safety function but with reduced resolution. At fixed blanking, the object cannot move around in the protection area. Other beams are active with normal resolution.

Test/reset ① (see 5): This pushbutton is connected to +24 VDC during normal operation. It has several functions:

A Test: If the light curtain is influenced during normal operation, its whole function is controlled. If the button (normally closed) is influenced, a physical contact within the protection area is simulated. The button must be affected for at least 2.5 s.

B Reset: (see 4.6) If a connected button is pressed and released (manual reset) when the protection area is clear again after having been disturbed, the light curtain is reset.

C Alignment: (see 3.2) If the button is pressed when voltage is connected, the barrier enters alignment mode, i.e., when the alignment of the upper and lower beam is correct, LED 1,2,3 and 5 are lit to indicate this.

D Override: (see 7) (Only and always possible when a LMS indicator is connected.) If the button is pressed after 2 s but within 5 s after voltage has been switched on, and is then pressed for at least 5 s, the OSSD outputs of the light curtain will be activated only if any beam is interrupted. This function is interrupted immediately when the button is released.

Reset of Focus light barrier can be reached in three different ways:

A Automatic reset: (see 4.6) The light curtain is reset immediately when the protection area is clear (= not open). Default setting by delivery.

B Manual reset: (see 4.6) The light curtain is reset immediately after the protection area is clear and the reset button is pressed and released.

C Time reset: (pre-reset) (see 4.6) The light curtain is reset when, first, the pre-reset button ③ (see 4.6) within hazardous area is pressed, and thereafter, if the protection area is clear, when within 8 s the reset button ① outside the protection area is pressed. Manual reset must be chosen in order to include this function.

Safety outputs (see 5.2) OSSD 1 and 2 are opened when the protection area is interrupted.

3 Mechanical Installation.

The location where the safety barrier is to be installed must fulfil the technical requirements. Prior to installation, the ambient temperature, electromagnetic and/or optical interference, among other things, should be taken into consideration.

3.1 Mechanical Assembly.

The profile of the light curtain is assembled with the accompanying brackets, and mounting screws that slide in the profile slots (see 17-19 & 22). These make it simplifies to adjust the transmitter and receiver in level with each other.

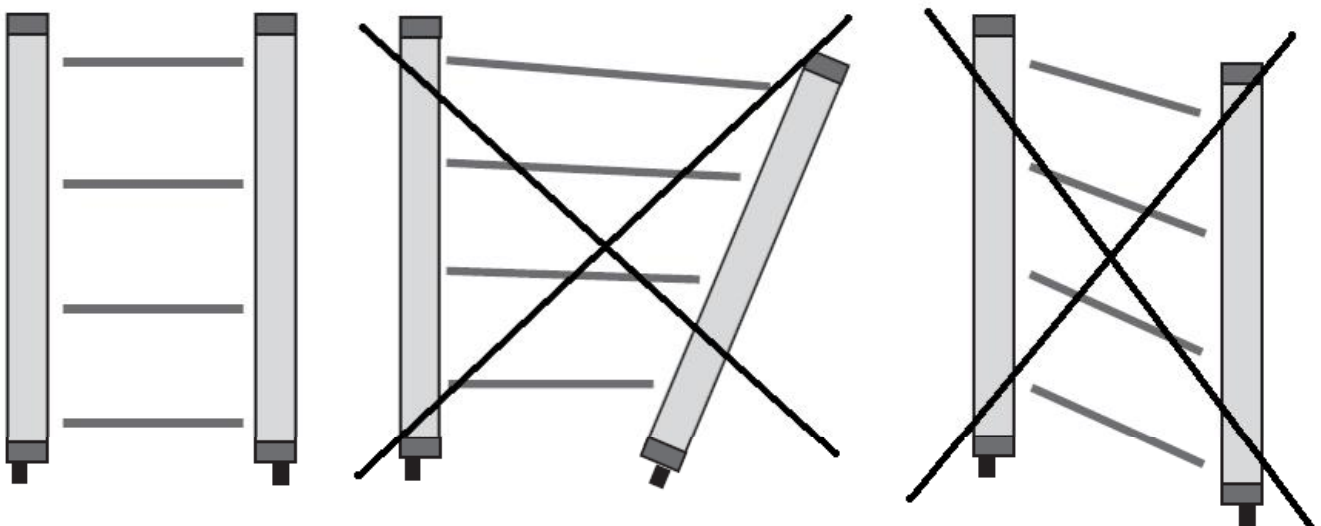

Note! If several barriers are used, they must be mounted so that each transmitter does not interfere with the receiver of a nearby barrier. Multiple barriers should be installed as below or could be used with code B, see 4.5 and 5.6.

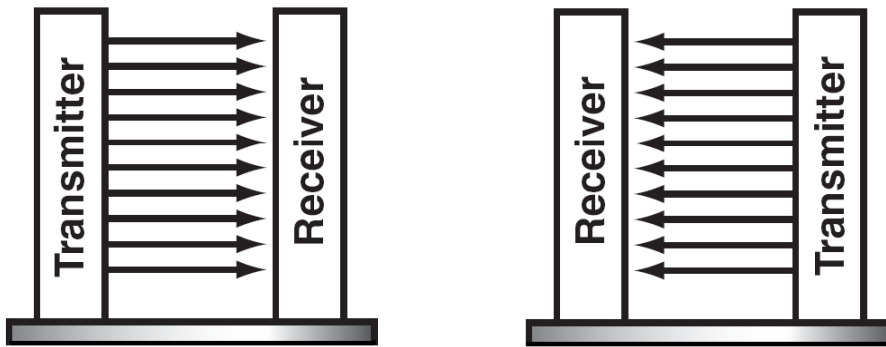

Code not necessary.

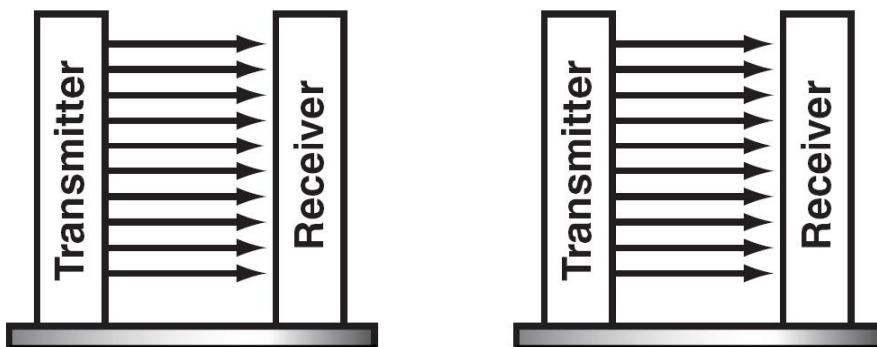

Code A default setting

Code B

The scan code feature of the Focus II system allows for placement of systems in close proximity and in line with each other. The distinctive coding of the beams provide for unique operation of a system while in view of another system with a different scan code. Two unique codes are available on the Focus II.

3.2 Alignment Procedure.

When the safety barrier has been mounted, optical alignment of transmitter and receiver is made as follows:

- Disconnect the barrier's power supply. Open the test/reset ① (see 5.1).
- Restore the barrier's power supply. The test/reset ① can then be closed again.
- Make sure that both units are in level, vertical and directed towards each other. Adjust by turning the transmitter, left and right, until LED 2 and 5 of the receiver are lit. Turn the transmitter both ways to find the outermost positions, return the transmitter to the midpoint. The barrier is correctly aligned when the LED 3 is constantly lit even if one of the profiles is somewhat turned.
- After aligning the barrier, secure the screws firmly.
- Disconnect the power supply.
- Restore the barrier's power supply (with the test/reset ① contact closed). If the safety area is clear and automatic reset is chosen, the barrier will immediately enter operating mode, i.e. the OSSD outputs are activated and the LED 1 and 3 are lit. If manual reset is chosen, test/reset ① must be pressed and released before the OSSD outputs are activated.
- Complete the checks described in section 13 "Final Checks" and 16 "Routine Checks and Maintenance".

Alignment laser JSRL-4

Facilitates alignment of barrier, especially when the solution contains one or more mirrors. JSRL-4 is easily mounted on the face of transmitter or receiver unit. Once the unit is mounted, switch on the directional laser so that the red laser point is visible, possibly via the mirror(s) of the corresponding unit.

JSRL-4 contains two batteries of type AAA, which are replaceable by unscrewing the bottom end lid.



3.3 Calculation of Minimum Distance for Installation.

Vertically assembled curtain: The safety distance S is the minimum distance between curtain and hazardous area which guarantees that no one comes in contact with dangerous machinery in operation before it stop's. For calculation of S for a curtain with multiple beams, the following formula is valid:

$$S = (K * T) + C$$

S = Safety distance in mm.

T = T1 + T2 where T1 = reaction time of machine in seconds.

T2 = reaction time of curtain in seconds.

K = movement velocity of body parts towards hazardous area:
2000 mm/s for FIIx-14 or 30, 1600 mm/s for FII-x-K versions

C = 8 * (d-14) mm where d = 14 for FII-x-14 and 30 for FII-x-30 curtain
= 850 mm for FII-x-K versions (grids)

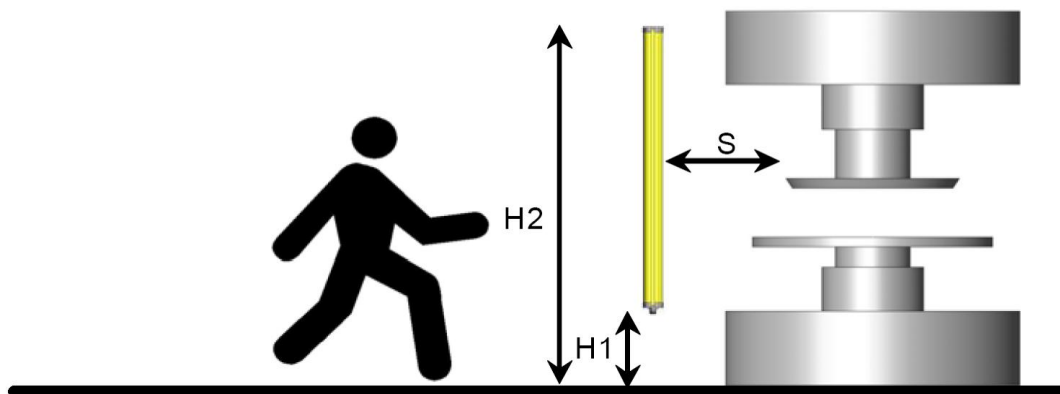

S = safety distance in mm.

H1 = the bottom beam must not have a height above 300 mm.

H2 = the top beam must not have a height below 900 mm.

Vertically assembled grid: The following table is valid only for vertically assembled light grid with 2, 3, or 4 beams (must never be assembled horizontally):

BEAM HEIGHT ABOVE FLOOR	4 beams 900 unit	4 beams 1200 unit	3 beams	2 beams
1st beam	300 mm	300 mm	300 mm	400 mm
2nd beam	600 mm	700 mm	700 mm	900 mm
3rd beam	900 mm	1100 mm	1100 mm	
4th beam	1200 mm	1500 mm		

Horizontally assembled curtain: The safety distance from hazardous machinery to the farthest beam is calculated using the same formula as above but with different parameters, as follows:

$$S = (K * T) + C$$

S = safety distance in mm.

T = T1 + T2 where T1 = reaction time of machine in seconds.

T2 = reaction time of curtain in seconds.

K = 1600 mm/s (movement velocity of body towards hazardous area).

C = 1200 - 0.4 * H. Must not be less than 850 mm.

H = 15 x (d-50 mm)

d = resolution.

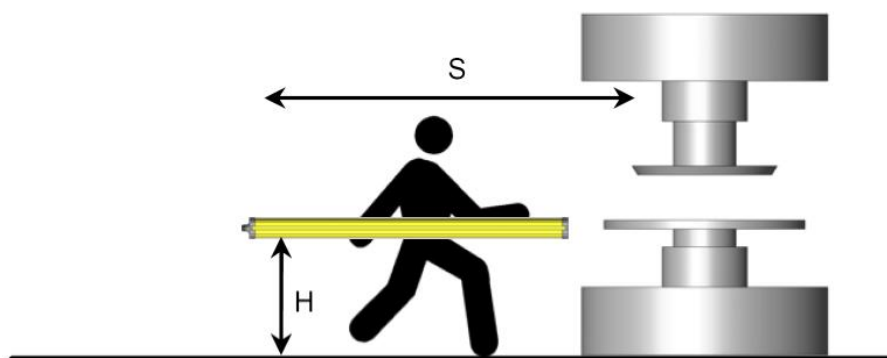

S = safety distance in mm.

H = the optical field must not be higher than 1000mm.

3.4 Distance to Reflecting Surfaces.

The barrier should be mounted so that the risk of reflection from reflecting surfaces is minimized. The minimum distance to a reflecting surface is shown below.

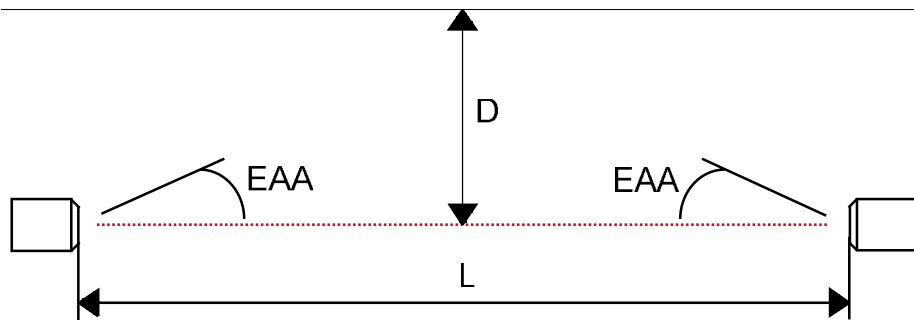

Operating range L: is the effective working distance of the Focus II system, from the transmitter to the receiver.

EAA: is the effective aperture angle of the Safety Sensor.
 it is $\pm 2,5^\circ$ for FII-4....
 it is $\pm 5^\circ$ for FII-2....

distance d: is the minimum distance to a reflective surface.
 This distance must be bigger than:
 $d_{min\ FII-4} = \tan(2,5^\circ) \times R$
 $d_{min\ FII-2} = \tan(5^\circ) \times R$

Be aware that surface interference may also appear above and below the sensing field.

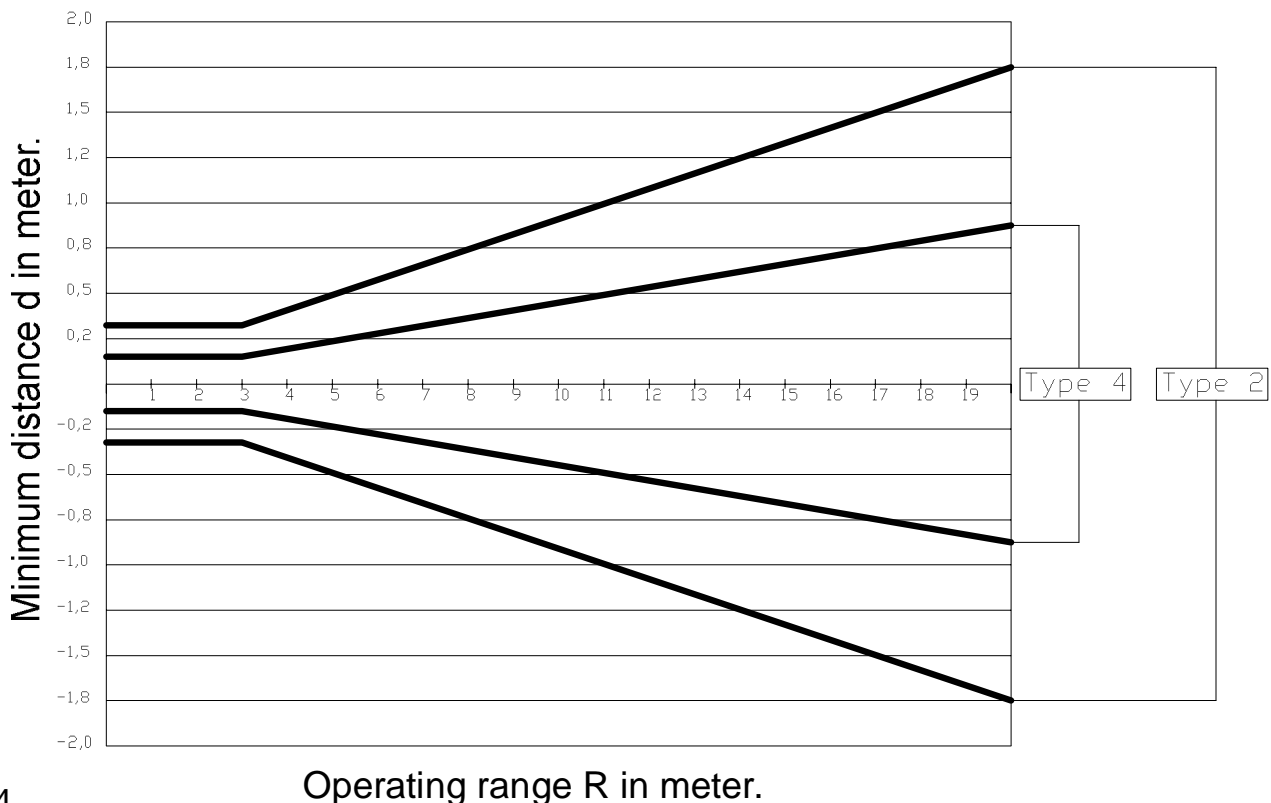

4 Electrical Installation.

4.1 Important Notes on Installation.

Note! The two OSSD outputs must be connected to the stop function of the machine, so that they each stop the hazardous machinery.
The Focus II system is by default in auto reset mode.

- Power to the system must be by a 24 VDC \pm 20%, supply which complies with standard EN 60742 (dual isolation), or with equivalent isolation by VDE 0551. We strongly recommend a stabilized power supply.
- Voltage must be disconnected when changing the installation.
- The screen of the cabling to the barrier must be connected to ground circuit.
- The barrier should be protected by a fuse with the value 1 A normal in the feeding voltage.
- The external muting indicator (LMS) signalling that the muting function is active, must be connected and working for the muting function to work. The indicator should be placed so that it is visible from all sides with access to the hazardous area of the machine. See connection example in 5 and text in 6.
- The OSSD outputs of the barrier are PNP outputs which are each current limited to 500 mA. If the current will exceed 500 mA or if alternating current is to be connected, the system may benefit from being connected to a safety relay, see 5.
- Do not install the Focus II system in the following types of environments:
 - Areas exposed to intense interference light, such as direct sunlight
 - Areas near the frequency controlled motors or wires to them
 - Areas near magnetic valves with coils without suppressors
 - Areas with high humidity where condensation is likely to occur
 - Areas where corrosive gases are present
 - Areas exposed to vibration or shock levels higher than in the specification
 - Areas where the product may come into contact with water
 - Areas where the product may come into contact with oil that is an adhesive solvent

Do not use radio equipment such as cellular phones, walkie-talkies, or transceivers near the Focus II system.

4.2 Connection of Cable C5, C8 in M12 C01-C04 Connectors.

Female 5-pin connector (M12 C01) for connection to transmitter:

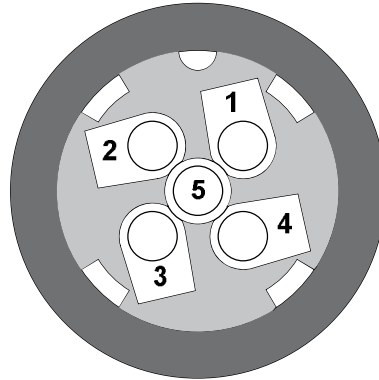
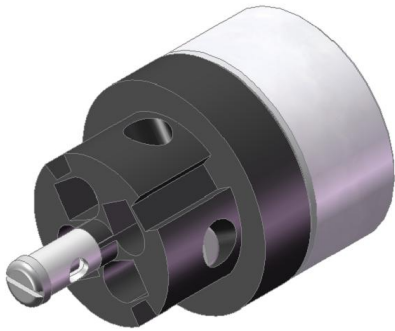

- 1 Brown
- 2 White
- 3 Blue
- 4 Black
- 5 Grey

Male 5-pin connector (M12 C02):

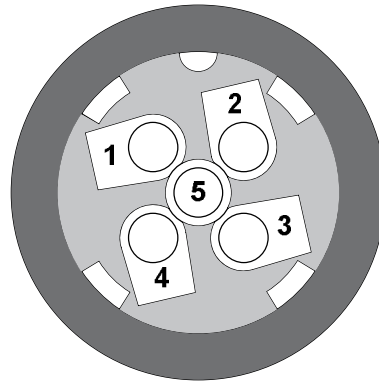
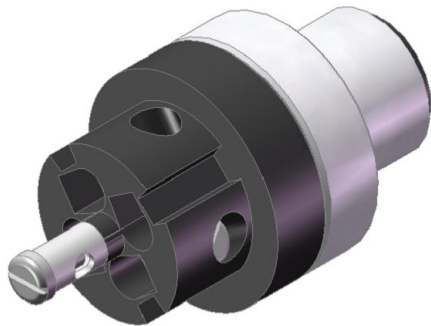

Female 8-pin connector (M12 C03) for connection to receiver:

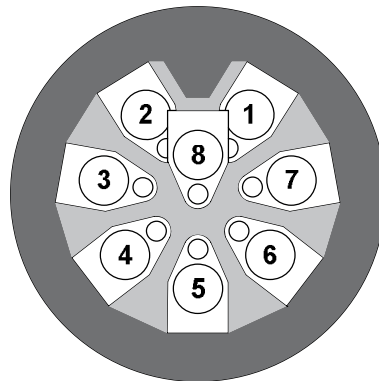
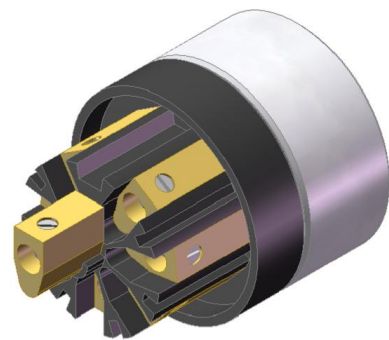

- 1 White
- 2 Brown
- 3 Green
- 4 Yellow
- 5 Grey
- 6 Pink
- 7 Blue
- 8 Red

Male 8-pin connector (M12 C04):

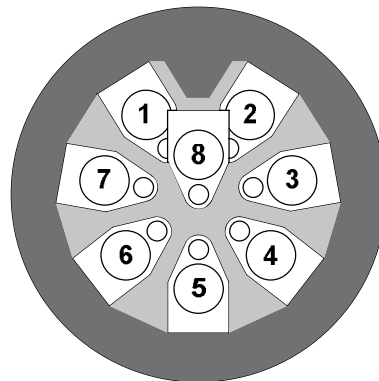
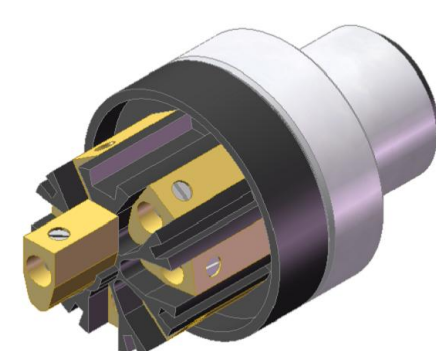

4.3 Setting up of Internal Change-Over Switches Transmitter.

- Disconnect the power supply to the unit and open the small lid in the bottom cap (with the M12 connector) so that the two change-over switches become visible.
- The change-over switches may be adjusted to the desirable position with a small, suitable screw driver.

Note! Make sure to always set switches in both banks to the same position. (except switch 4 on the transmitter)

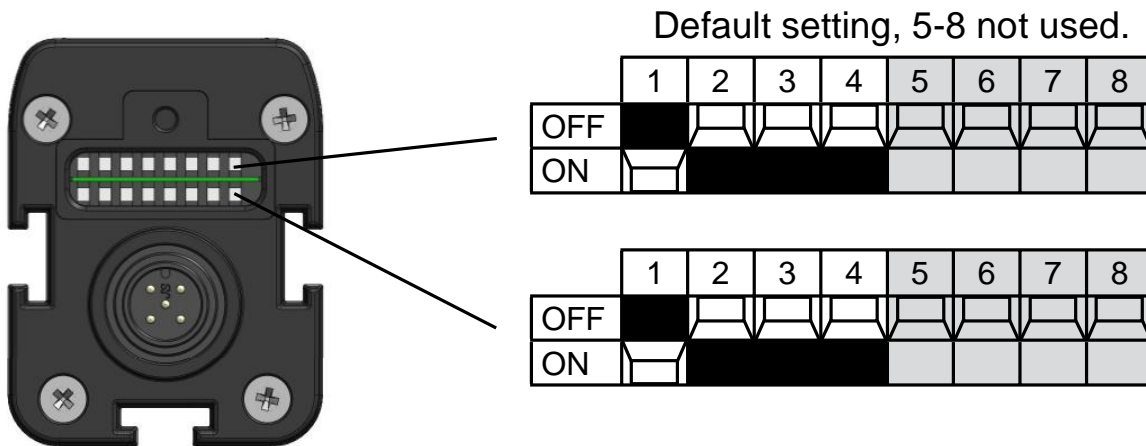

Selector switches 5 - 8 are not used in the transmitter.

Switch position	Setting	Function	
1	OFF	Range setting	X
	ON		Short range
2	OFF	Range setting	X
	ON		Long range
3	OFF	Code setting	No coding
	ON		Coding
4	OFF	Code setting	Code A
	ON		Code B

Please refer to the table below for the range setting:

Switch 1	Switch 2	Range selected
OFF	OFF	Not allowed
OFF	ON	Long range
ON	OFF	Short range
ON	ON	Not allowed

4.4 Setting up of Internal Change-Over Switches Receiver.

- Disconnect the power supply to the unit and open the small lid in the bottom cap (with the M12 connector) so that the two change-over switches become visible.
- The change-over switches may be adjusted to the desirable position with a small, suitable screw driver.

Note! Make sure to always set switches in both banks to the same position. (except switch 7 on the receiver)

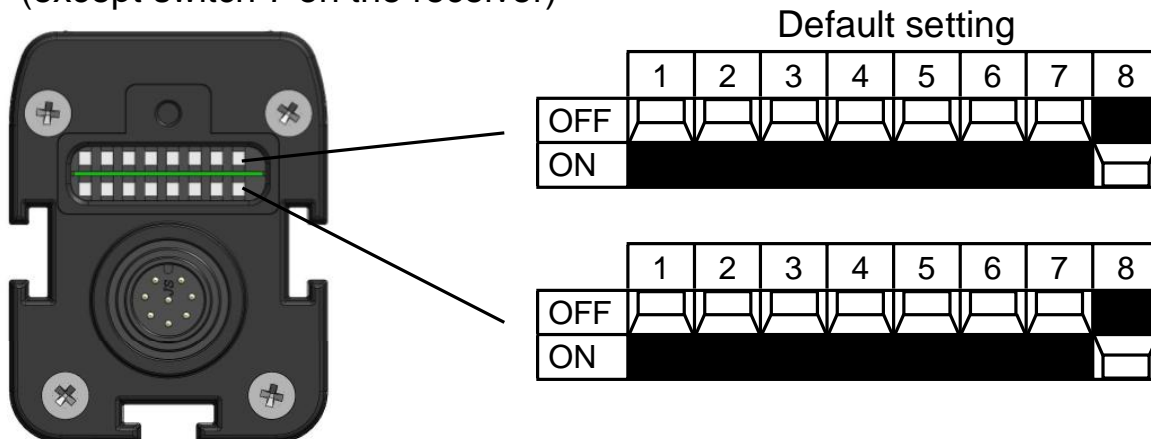

Switch	Status	Function		
8	OFF	Manual reset	Single break if SB/DB selected	
	ON	Automatic reset	Double break if SB/DB selected	
7	OFF	Refer to Coding section for further information		
	ON			
6	OFF	EDM function disabled		
	ON	EDM function enabled		
5 + 4 ¹	4	5	Muting and special functions	
	OFF	OFF	Muting T with time limit	
	OFF	ON	Muting L with time limit	
	ON	OFF	Muting X without time limit	
	ON	ON	Special function with switches 1,2 and 3	

			Muting maps when muting T,L or X are selected on switches 4 and 5 ²	Special functions selection when switches 4 and 5 are both ON ³	
3+2+1	1	2	3		
	OFF	OFF	OFF	Muting all beams	Blanking ± 1 beam with T muting
	OFF	OFF	ON	Muting on module 1,2,3 and 4	Blanking +1/-0 beam with T muting
	OFF	ON	OFF	Muting on module 1,2 and 3	Blanking ± 0 beam with T muting
	OFF	ON	ON	Muting on module 1 and 2	Blanking ± 1 beam with L muting
	ON	OFF	OFF	Muting on module 1	Blanking +1/-0 beam with L muting
	ON	OFF	ON	Muting on module 2	Blanking ± 0 beam with L muting
	ON	ON	OFF	Muting on module 3	Pre-Reset mode
ON	ON	ON	Muting on module 4	Single break/double break, Switch 8	

1. Selector switches 4 and 5 are operational if a muting indicator is connected or both are set to the ON position.
 2. Selector switches 1, 2 and 3 are operational if a muting function is set and a muting indicator is connected.
 3. Selector switches 1, 2 and 3 are operational if selector switches 4 and 5 are in ON position.

4.5 Setting up Scan Codes.

The Focus II transmitter and receiver has the possibility to coding selection to minimize interference when two transmitters can reach one receiver.

Note! Both transmitter and receiver must be set to the same code.

All LED's on transmitter / receiver blink twice when code B is set correct, when powering up. Default code one blink.

Please make sure that the total cable length between the transmitter and receiver does not exceed 100m.

Transmitter

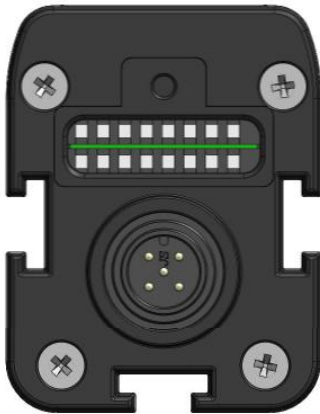

Switch 3	
OFF	No code (exclusion of dip 4)
ON	Code on

Switch 4	
OFF	Code A
ON	Code B

Receiver



Switch 7 Upper bank	
OFF	Code A
ON	Code B

Switch 7 Lower bank	
OFF	No code (exclusion of dip 7 upper bank)
ON	Code on

4.6 Choice of Reset Procedure.

Reset of Focus barrier may be reached in three different ways:

- A Automatic reset:** The barrier is reset directly after the protection area has become clear. Change-over switch No. 8 is set in position "On" (see 4.4).
- B Manual reset:** The barrier is reset when the protection area is clear and the reset button has been pressed and released. Change-over switch No. 8 is set in position "Off" (see 4.4).
- C Time reset: (pre-reset)** The barrier is reset when, first, the pre-reset button ③, which is normally placed inside hazardous area, has been pressed (the yellow LED 5 in receiver is blinking) and, thereafter, if the protection area is clear, within 8 seconds the reset button ① outside the area has been pressed and released (see connection example below). Change-over switch No. 8 in the receiver is set in position "Off" (manual reset) (see 4.4).

Connection example by time reset (pre-reset)

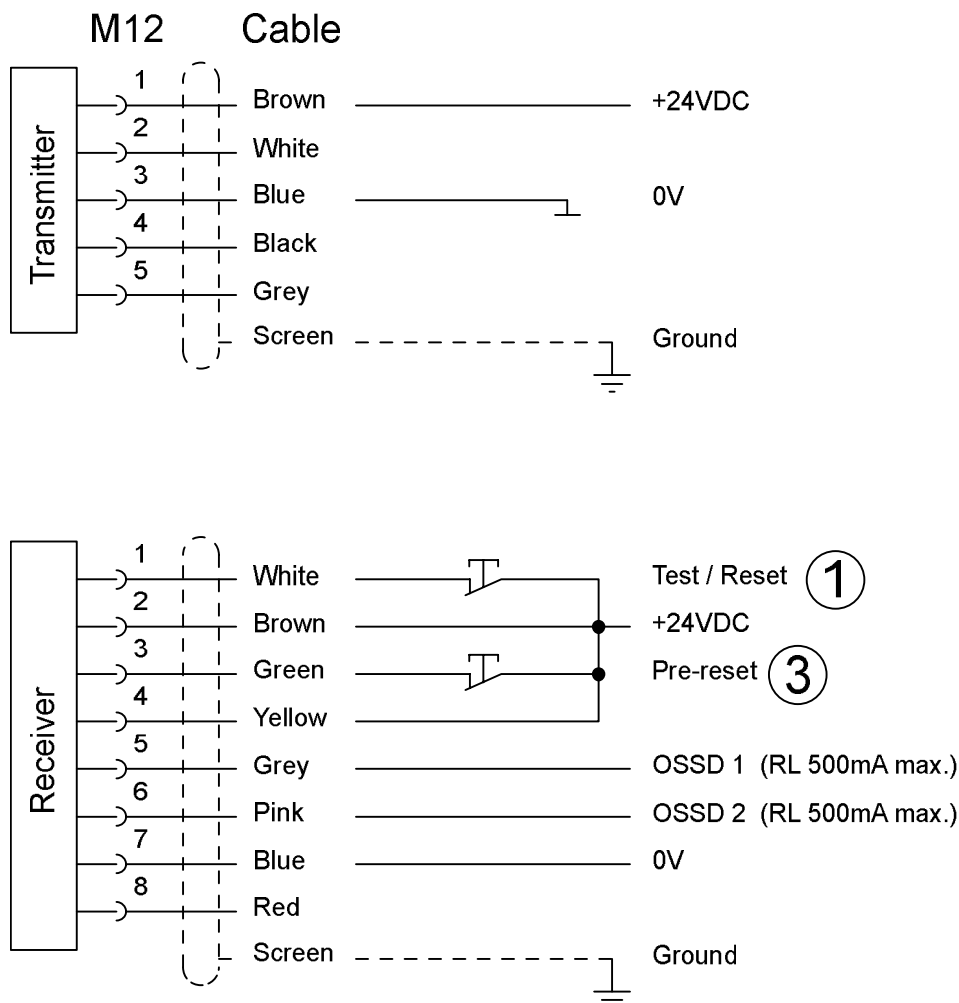

5 Connection Examples.

Note! Mirror units like FII-x-K1C 500 with transmitter/receiver in one unit and a mirror unit is connected electrically like the receiver below.

5.1 Connection Example, Basic with and without muting.

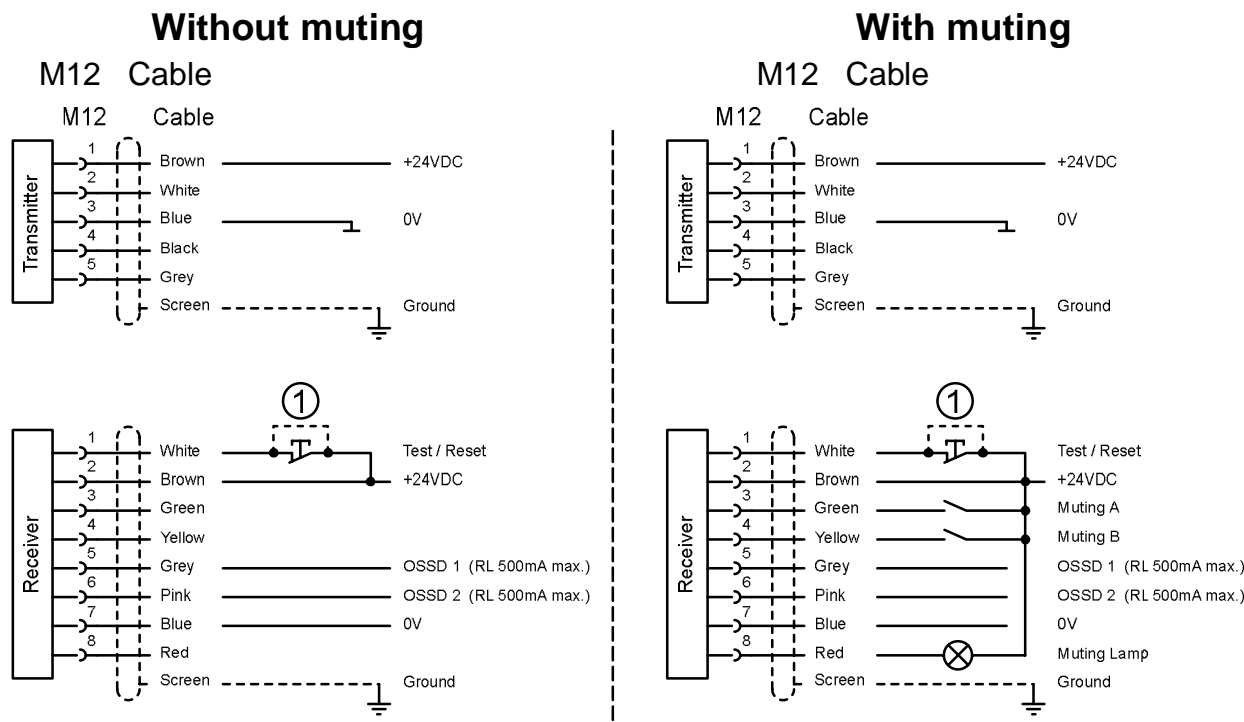

Focus barrier is reset manually with the test/reset button ① or, as by delivery, automatically, when switch 8 in the receiver is in the position “On” (see 4.4). Test/reset ① is also used during normal operation when testing, aligning, and overriding, with the muting function used (see 2).

Note! If test/reset button ① is not used,
the white conductor must be connected to 24VDC.

5.2 Connection Example, for connection to safety relay.

There are alternative possibilities for reset (see the following examples):

a) Automatic reset - The safety relay is connected for automatic reset and terminal 1 (white cable) on the receiver is connected to 24VDC.

b) Manual Reset from relay – The safety relay is connected for Manual reset and terminal 1 on the receiver (white cable) is connected to 24VDC

c) Manual Reset from Light Barrier – The safety relay is connected for automatic reset and terminal 1 (white cable) on the receiver is connected to one side of a push button (NC) and the other side is connected to 24VDC.

Switches 8 is set in “ON” position as default from factory for connection examples (see 4.4). If example c is required then Switch 8 must be set to “OFF”. If test/reset ① is also connected it may be used for other functions (see 2). The LMS indicator L1 signals opened barrier or safety relay.

Note! If test/reset ① is not connected, the white wire must be connected to 24VDC. If test/reset ① and ② are pressed and are released at the same time, no reset occurs.

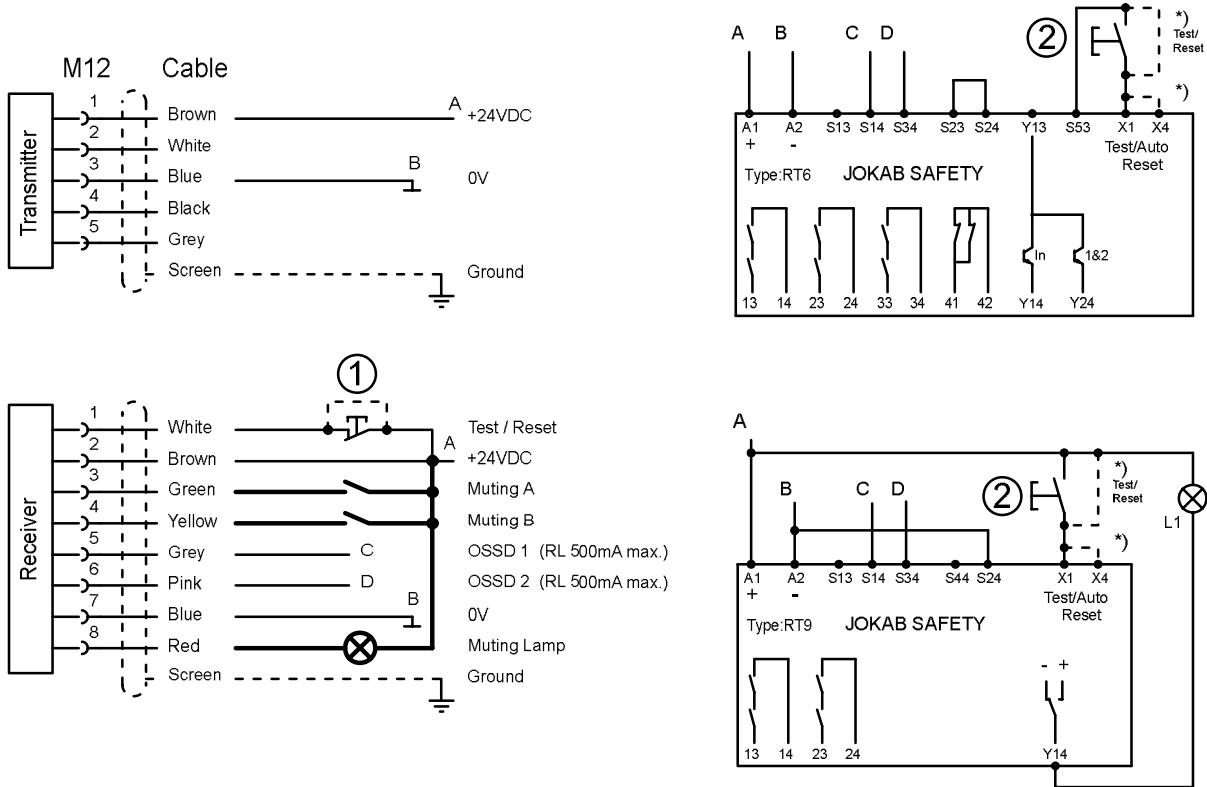

Note! The connections in the drawing above which are marked with bold lines should only be made if the muting function is to be used.

5.3 Connection Example, muting unit to safety relay.

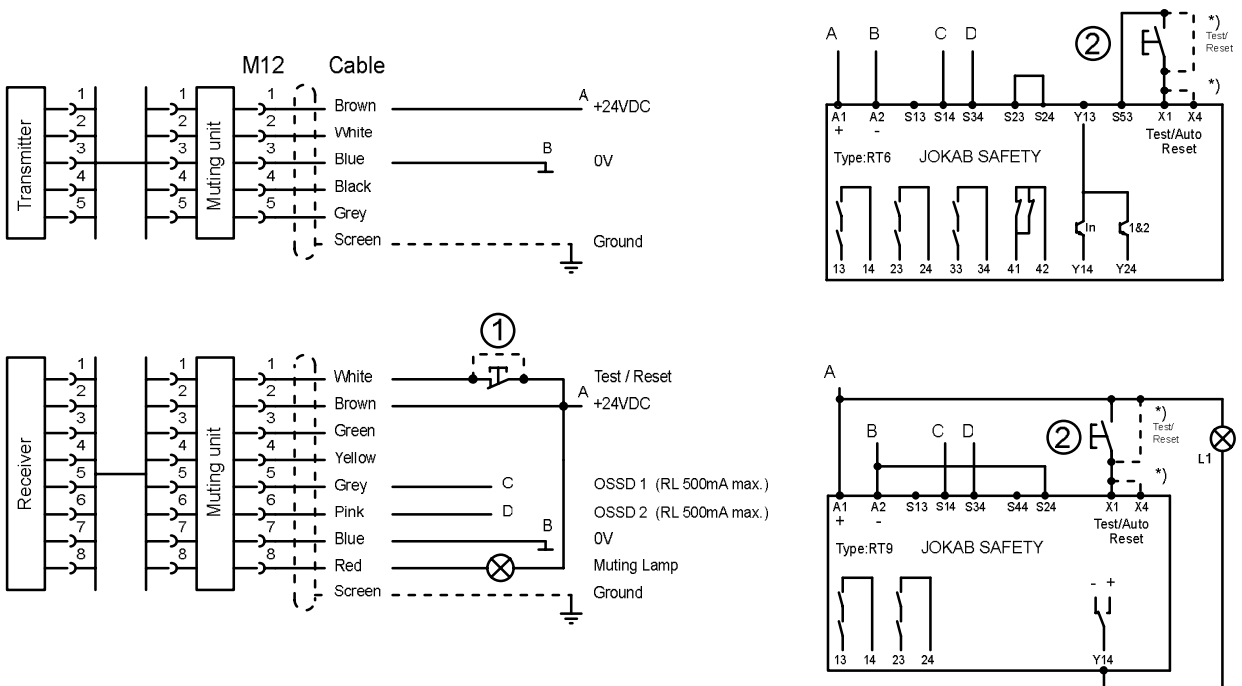

5.4 Connection Example, Vital / Pluto with Tina units.

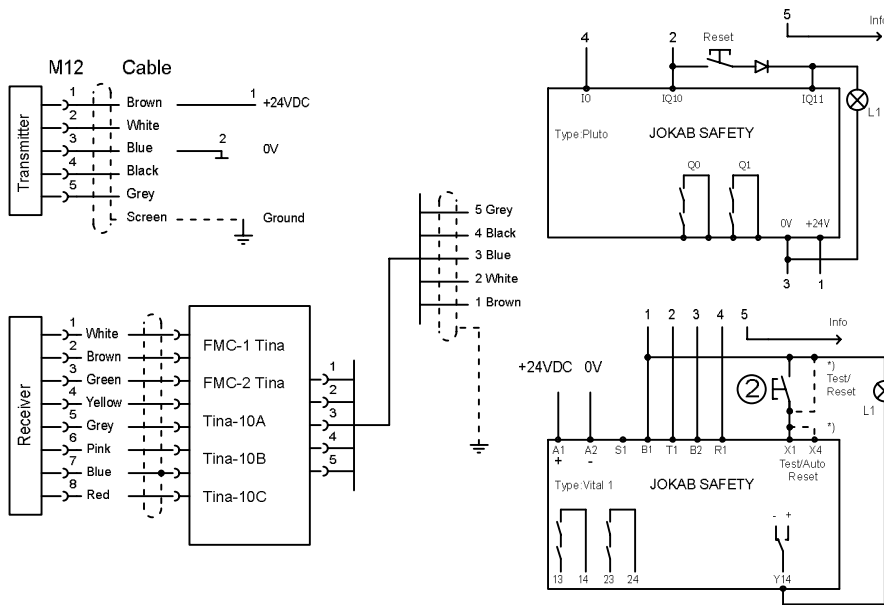

5.5 Connection Example, Pluto.

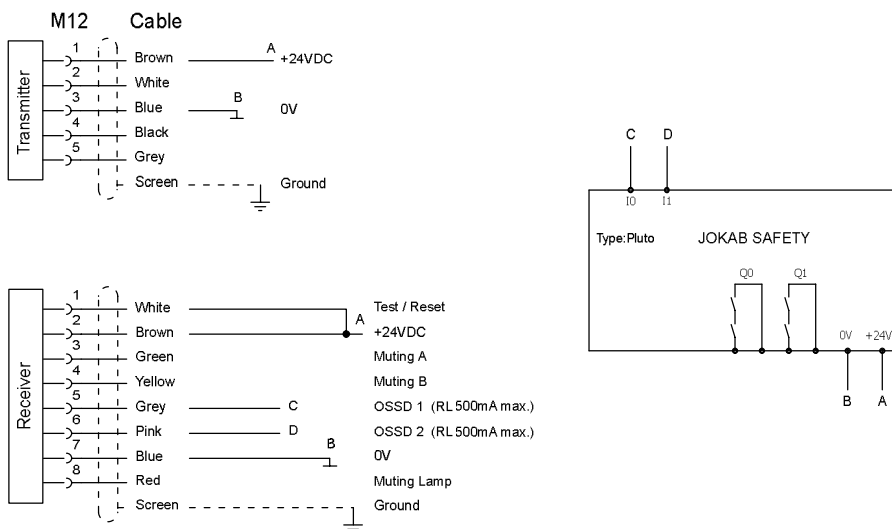

5.6 Connection Example, for connection of Code B.

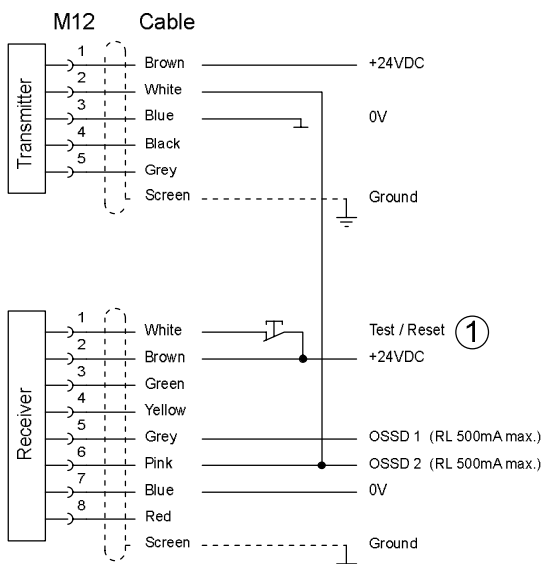

For further information see 3.1, 4.5

5.7 Specifications for Available Variants.

Light curtain/barrier variants: see 1.

The following tables show protection height, length, and reaction time for light curtain Focus FII-x-14 with 14mm resolution and Focus FII-x-30 with 30mm.

The columns Number of modules and Number of beams per module refer to the muting function (see chapter 6.6 and table in chapter 4.4).

Type No. x: 4 = type 4, 2= type2. Measures L,F,E and A see 5.8

Type No.	Article No. 22-xxx-yy		Measures				Reaction time			No. of Beams		
	Type 4 xxx-yy	Type 2 xxx-yy	L	F	E	A	-OFF W	-OFF N	-ON	total	No. of modules	per module
FII-x-14-150	200-00	206-00	232	161	147	65	18	12	138	21	7	3
FII-x-14-300	200-10	206-10	380	308	294	65	23	15	135	42	7	6
FII-x-14-450	200-20	206-20	526	455	441	65	29	19	131	63	7	9
FII-x-14-600	200-30	206-30	673	602	588	65	35	23	127	84	7	12
FII-x-14-750	200-40	206-40	821	749	735	65	40	26	123	105	7	15
FII-x-14-900	200-50	206-50	967	896	882	65	46	30	119	126	7	18
FII-x-14-1050	200-60	206-60	1114	1043	1029	65	52	34	116	147	7	21
FII-x-14-1200	200-70	206-70	1262	1190	1176	65	58	38	112	168	7	24
FII-x-14-1350	200-80	206-80	1409	1337	1323	65	63	42	108	189	7	27
FII-x-14-1500	200-90	206-90	1556	1484	1470	65	69	46	104	210	7	30
FII-x-14-1650	201-00	207-00	1679	1631	1617	65	75	50	100	231	7	33
FII-x-14-1800	201-10	207-10	1850	1778	1764	65	80	53	97	252	7	36
FII-x-14-1950	201-20	207-20	1997	1925	1911	65	86	57	93	273	7	39
FII-x-14-2100	201-30	207-30	2144	2072	2058	65	92	61	93	294	7	42
FII-x-14-2250	201-40	207-40	2291	2219	2205	65	97	64	98	315	7	45
FII-x-14-2400	201-50	207-50	2439	2366	2352	65	103	68	104	336	7	48

FII-x-30-150	201-60	207-60	232	177	147	65	14	9	141	8	4	2
FII-x-30-300	201-70	207-70	380	324	294	65	16	11	139	16	4	4
FII-x-30-450	201-80	207-80	526	471	441	65	19	13	138	24	4	6
FII-x-30-600	201-90	207-90	673	618	588	65	21	14	136	32	4	8
FII-x-30-750	202-00	208-00	821	765	735	65	23	15	135	40	4	10
FII-x-30-900	202-10	208-10	967	912	882	65	25	17	133	48	4	12
FII-x-30-1050	202-20	208-20	1114	1059	1029	65	27	18	132	56	4	14
FII-x-30-1200	202-30	208-30	1262	1206	1176	65	29	19	131	64	4	16
FII-x-30-1350	202-40	208-40	1409	1353	1323	65	32	21	129	72	8	9
FII-x-30-1500	202-50	208-50	1556	1500	1470	65	34	22	128	80	8	10
FII-x-30-1650	202-60	208-60	1679	1647	1617	65	36	24	126	88	8	11
FII-x-30-1800	202-70	208-70	1850	1794	1764	65	38	25	125	96	8	12
FII-x-30-1950	202-80	208-80	1997	1941	1911	65	40	26	123	104	8	13
FII-x-30-2100	202-90	208-90	2144	2088	2058	65	42	28	122	112	8	14
FII-x-30-2250	203-00	209-00	2291	2235	2205	65	45	30	120	120	8	15
FII-x-30-2400	203-10	209-10	2439	2382	2352	65	47	31	119	128	8	16

Note!

Reaction time

-OFF W: is when the synchronization beam is interrupted which are the beam furthest away from the information LED's.

-OFF N: is when some or all except the synchronization beam is interrupted.

Type No. x: 4 = type 4, 2= type2.

Measures L,I,E and A see 5.8

Type No.	Article No. 22-xxx-yy		L	I	E	A	Recation		Total number of beams	Number of modules	Number of beams per module
	Type 4 xxx-yy	Type 2 xxx-yy					time -OFF	time -ON			
FII-x-K2-500	-204-00	-210-00	698	500	512	150	13	142	2	2	1
FII-x-K3-800	-204-10	-210-10	998	400	812	150	13	142	3	3	1
FII-x-K4-900	-204-20	-210-20	1098	300	912	150	13	142	4	4	1
FII-x-K4-1200	-204-30	-210-30	1398	400	1212	150	13	141	4	4	1
FII-x-K2-500 D	-204-40	-210-40	698	500	512	150	13	142	2 (4)	2	2
FII-x-K3-800 D	-204-50	-210-50	998	400	812	150	13	142	3 (6)	3	2
FII-x-K4-900 D	-204-60	-210-60	1098	300	912	150	13	142	4 (8)	4	2
FII-x-K4-1200 D	-204-70	-210-70	1398	400	1212	150	13	142	4 (8)	4	2
Light grid with transmitter/receiver on one side and a passive mirror unit.											
FII-x-K1C-500	-204-80	-210-80	698	500	512	150	12	142	1 (2)	1	1
FII-x-K2C-800	-204-90	-210-90	998	400	812	150	13	142	2 (4)	2	1
FII-x-K2C-900	-205-00	-211-00	1098	300	912	150	13	142	2 (4)	2	1
FII-x-K2C-1200	-205-10	-211-10	1398	400	1212	150	13	141	2 (4)	2	1

Weight of Focus II Light curtains

FII-x-yy-	150	300	450	600	750	900	1050	1200	1350	1500	1650	1800	1950	2100	2250	2400
Kg	0,83	1,39	1,95	2,51	3,07	3,63	4,19	4,75	5,31	5,87	6,43	7,0	7,55	8,11	8,67	9,24

Weight of Focus II Light grids

FII-x-Ky-	500	800	900	1200	500 D	800 D	900 D	1200 D	500 LD	800 LD	900 LD	1200 LD
Kg	2,43	3,39	4,65	5,51	2,95	3,91	5,17	6,03	2,43	3,39	4,65	5,51

Weight of Focus II Light grid with passive mirror units

FII-x-K1C-	500	FII-x-K2C-	800	900	1200
Kg	2,43	Kg	3,39	4,65	5,51

Muting units

Type No.		L	Number of beams	Range m	Weight kg
MFII-L	-212-00	640	2	0,2-10	2
MFII-T	-212-10	1250	4	0,2-10	3
MFII-L Reflex	-212-20	640	2	0,2-6	2
MFII-T Reflex	-212-30	1250	4	0,2-6	3

5.8 Dimensional Drawing.

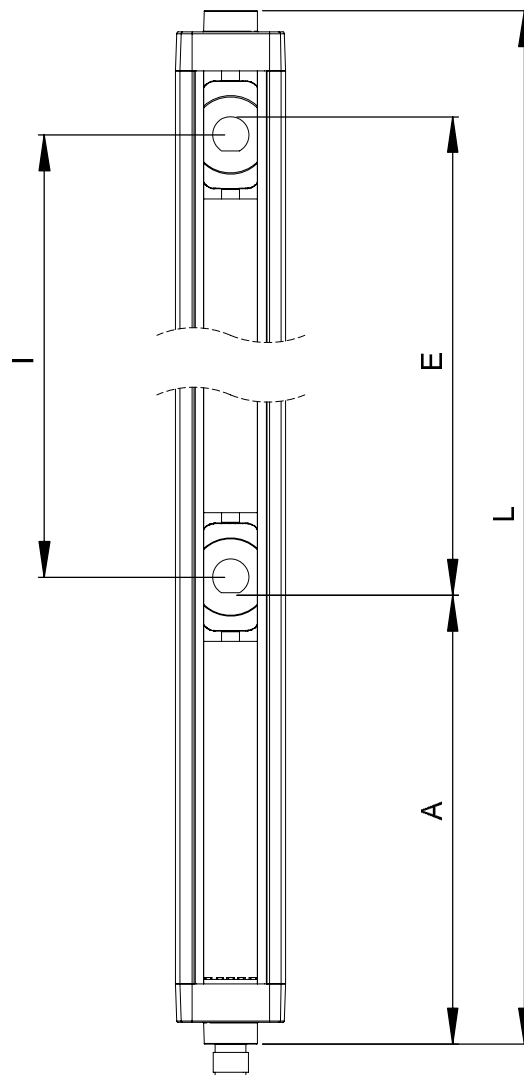
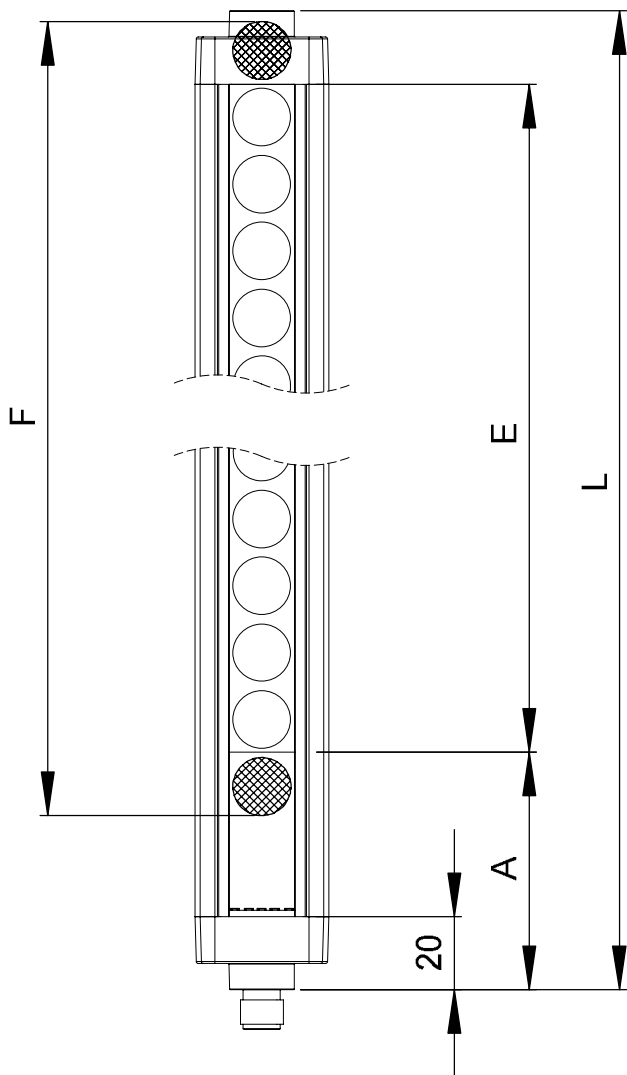

L: Total length of the Focus II system
 F: Protective height where an object equal or greater to the resolution is detected.
 E: Detection zone
 A: Dead zone

L: Total length of the Focus II system
 I: Beam distance
 E: Detection zone
 A: Dead zone

5.9 Label description

Model:		Supply:		Power consumption:	Protection:	SW release:	 JOKAB SAFETY A MEMBER OF THE ABB GROUP Made in Sweden Boplatsgatan 3, 213 76 Malmö www.jokabsafety.com
A		B		C	D	E	
Type:	Resolution: (mm)	Protection height: (mm)	Response time: (See manual)	Operating temp.:	Manufacturing date:		
F	G	H	I	J	K		
Range:		Bar code			Serial no.:		M
L							

A Model type: e.g. FRII-4-14-600
 B Power supply: 24VDC
 C Power consumption: e.g. 5W
 D Protection: IP67
 E Software release: e.g. 1.2.2
 F Type: 2 or 4
 G Resolution: e.g. 14 or 30mm (21/28 or 45/60)

H Protection height: e.g. 600 mm
 I Response time: e.g. 35 ms
 J Operating temperature: -10 / +55°C
 K Manufacturing date: e.g. 100211
 L Range: e.g. S 0,2-07m, L 07-14m
 M Serial number: e.g. 000116

6 Muting.

General information about the three functions

The functions muting, override, and blanking make it possible to bypass the barrier, or parts of it, when the operational mode allows this.

The barrier, by the demands in the given standard, is equipped with inputs that are necessary for these functions to be activated. It is important, however, to note that these functions bypass parts of the protective function, so it is essential that they are used wisely.

6.1 Muting, Installation.

The muting function is made possible in all Focus barriers when a muting indicator (or 220 Ω resistance 3 W) is connected and working at the moment when power is switched on.

The muting function is activated if the OSSD outputs are active and the inputs A and B are then closed. Sensor A must be activated at least 3 ms ahead of B or for the X-muting either A or B activates 3 ms before the other.

The muting function remain as long as the terms are met (indicator working, A and B activated). See 5.

If the muting function is possible and something happens to the muting indicator, or it is removed without first disconnecting the power supply to the barrier, the LED's of the barrier will indicate an error in the muting indicator, according to the description in 15, and all muting attempts are ignored.

The muting function is easily disabled by disconnecting the muting indicator and then switching on the power supply.

Note! A feature of the Focus safety barrier is that, depending on how the change-over switches (1-3) in the receiver are set (see 4.4), more or fewer beams of the protection area may be bypassed (muting) when it is intended for the material to pass. The rest of the area remains intact with normal protection and safety level.

This is an important function which decreases the possibility for a person to "accompany" material passing the barrier.

6.2 Muting, Modes.

The Focus II system offers a set of three muting modes:

- T-muting activation (default) with time limit
- L-muting activation with time limit
- X-muting activation without time limit

Note!

Time limitation can be removed on T and L muting when the light curtain is ordered. Can not be changed by the customer.

Features - Muting grid

Bypassing of light curtain or grid in one or two directions (L-form, T-form).
Connected directly via a M12 cable to light curtain/grid.

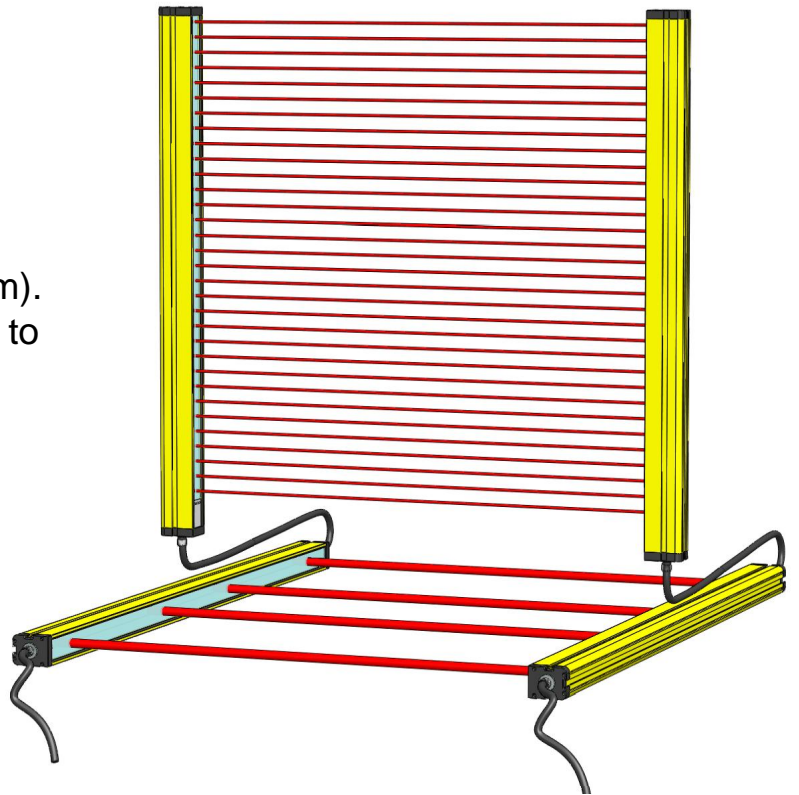
**6.3 T-Activation Mode.**

The T-muting activation mode is the default and standard application for muting. Four muting sensors are used in two pairs (OR function), connected to the two Muting inputs, Muting A and Muting B.

This muting activation mode allows bi-directional transport of material.

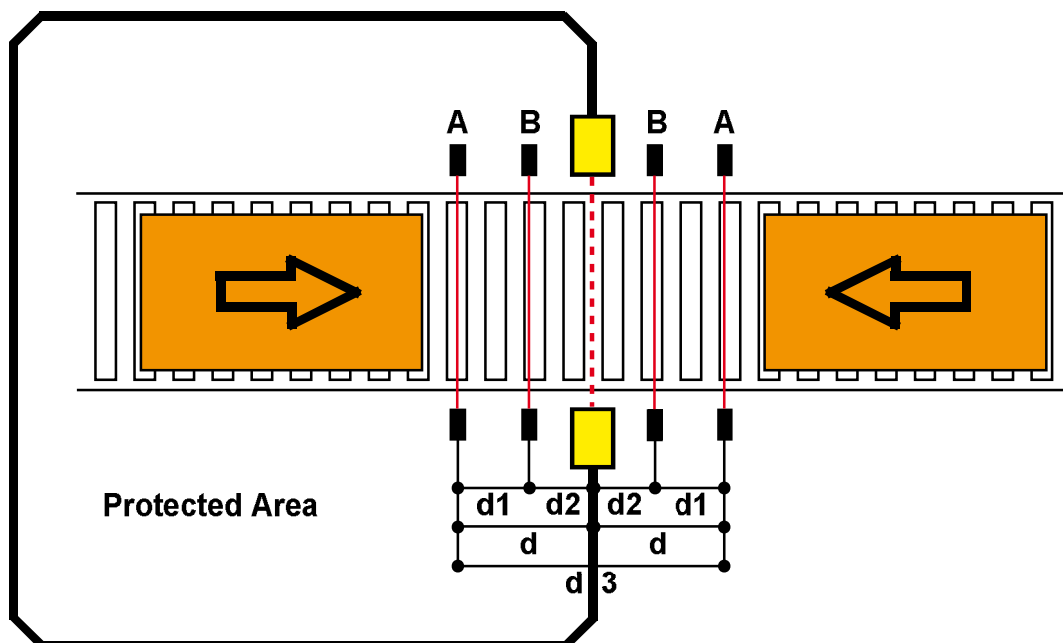

Note!

- d_1 is the distance between the muting sensors. It must be more than 250 mm and needs to be checked additionally in regards to the speed of the material transport and time limitation in the muting function.
- d_2 is the distance between the Muting sensor B and the Focus II system. It must be as short as possible. Timing limitations and the speed of the material transport must be considered additionally.
- d_3 is the distance between the two sensors connected to Muting A input. This distance represents the minimum length of the material to be detected.

Timing requirements and limitations:

- If Muting A is activated, Muting B must be activated within 120sec. to activate the muting function. Otherwise muting function is stopped.
- Muting A and Muting B cannot be activated at the same time. A minimum time difference is approximately 3ms and is mandatory.
- Maximum muting time is 600sec. After this time, muting function is stopped even if the Muting inputs are still active.
- The Focus II allows that Muting A or Muting B drop for a maximum time of 200ms without stopping the muting function. A time longer than 200ms is detected as a muting stop.

6.4 L-Activation Mode.

The L-muting activation mode can be used in applications where material is transported only out from the dangerous area. Two muting sensors are connected to the two Muting inputs, Muting A and Muting B.

This muting activation mode can only be used in uni-directional transport. Failure to do so may result in serious injury.

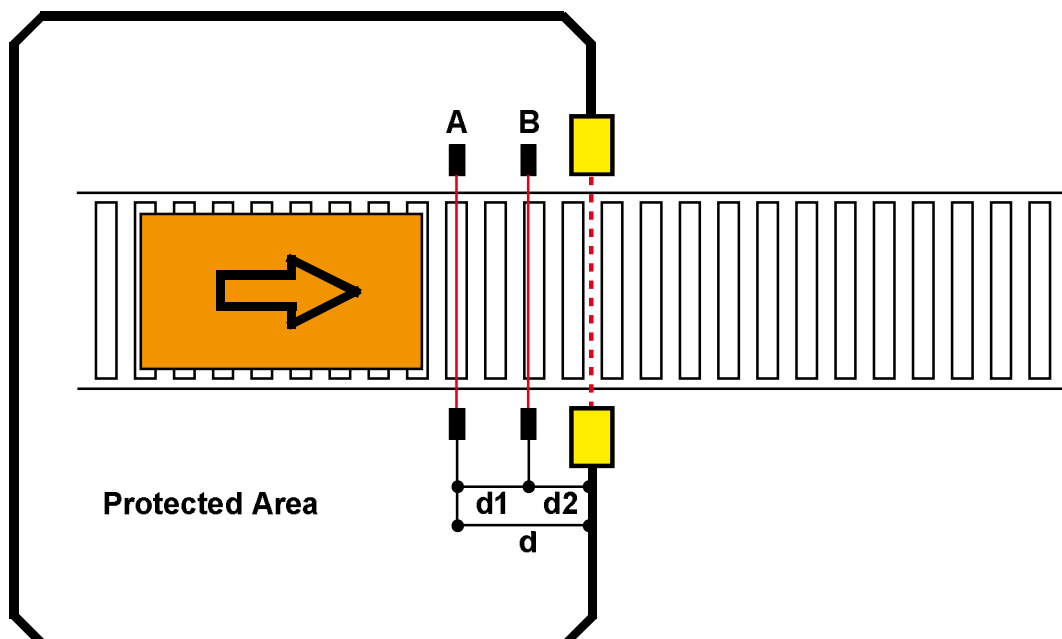

Note!

- d1 is the distance between the muting sensors. It must be more than 250mm and needs to be checked additionally in regards to the speed of the material transport and time limitation in the muting function.
- d2 is the distance between the Muting sensor B and the Focus II system. It must be as short as possible. Timing limitations and the speed of the material transport must be considered additionally.
- d is the distance between the Focus II system and the sensor connected to Muting A input. This distance represents the minimum length of the material to be detected.

Timing requirements and limitations:

- If Muting A is activated, Muting B must be activated within 120 sec. to activate the muting function. Otherwise muting function is stopped.
- Muting A and Muting B cannot be activated at the same time. A minimum time difference is approximately 3ms and is mandatory.
- If Muting A and Muting B are activated, the protective field must be obscured within 120 sec. Otherwise the muting function is stopped.
- Maximum muting time is 600 sec. After this time, muting function is stopped even if the Muting inputs are still active or the protective field is still obscured.
- The Focus II allows that Muting A or Muting B and the whole protective field to drop for a maximum time of 200 ms without stopping the muting function. A time longer than 200 ms and the muting function stop's.

6.5 X-Activation Mode.

The X-muting activation mode allows bi-directional transport of material.

This muting mode is used in applications, where eg. pallets are used to carry stacked boxes or crates. Most stable detection of this kind of material is possible using the X-muting activation mode. Two muting sensors are connected to the two Muting inputs, Muting A must be a sensor with high output (NO) and Muting B must be a sensor with low output (NC) as normal state.

The crossing point of the two muting sensors should be inside the dangerous zone. Failure to do so may result in serious injury.

Note!

- Muting sensors must be NO on A and NC on B to get this function.
- d is the resulting distance between the activation points of Muting A and Muting B. It needs to be checked in regards to the speed of the conveyor.

Timing requirements and limitations:

- Either Muting A or Muting B can be used to initiate the muting function.
- There is no maximum time limit after Muting A is activated.
- There is no maximum time limit after Muting B is activated.
- Muting A and Muting B cannot be activated at the same time. A minimum time difference is approximately 3ms and is mandatory.
- Muting time is infinite.
- The Focus II allows that Muting A or Muting B drop for a maximum time of 200 ms without stopping the muting function. A time longer than 200 ms is detected as a muting stop.

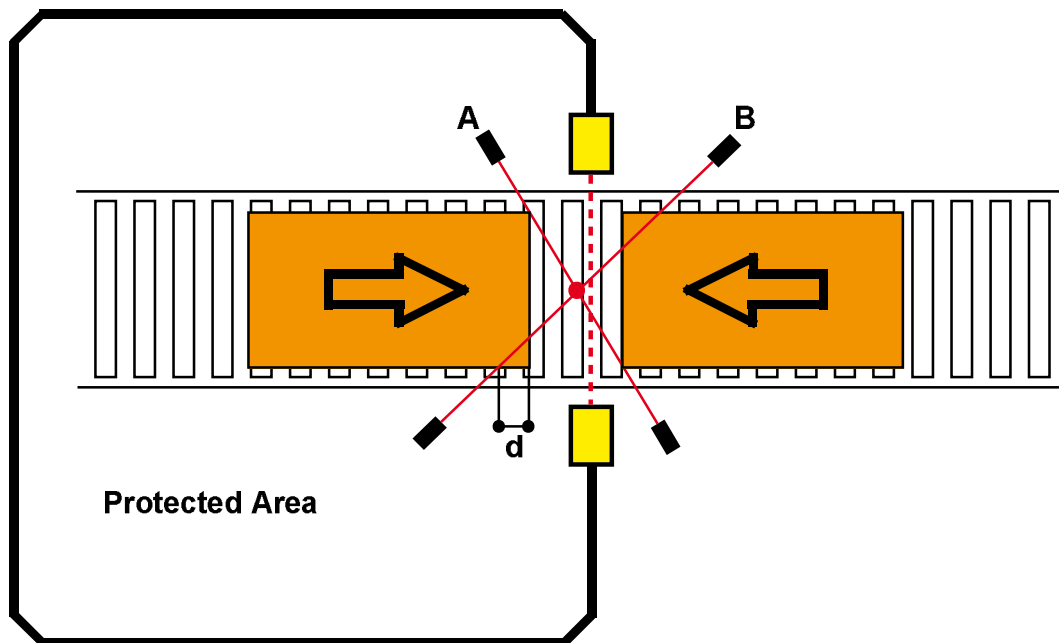

6.6 Partial Muting.

A module is a section of the barrier, the size of which is defined in the tables in 5.7. The first module is always the one next to the indicator LED's. E.g. Focus FII-4-30-600 consists of 4 modules, each containing 8 beams, giving a total of 32 beams in the whole barrier.

Switches 4 and 5 has to be set according to the chosen muting function (T,L or X). Switches 1, 2, and 3 in the receiver are set according to the choice of muting all modules, single module or a combination of several modules. See 4.4. Default setting is for muting of all modules (1, 2, and 3 are in the position "Off").

Muting of a single module makes it possible to disconnect only one module at every muting moment. Muting of several modules makes it possible to disconnect two or more modules, or even the whole barrier.

The locations of the modules are shown in this drawing:
For detailed information about how many beams are included in one module and which switches to set see table at 4.4 and 5.6.

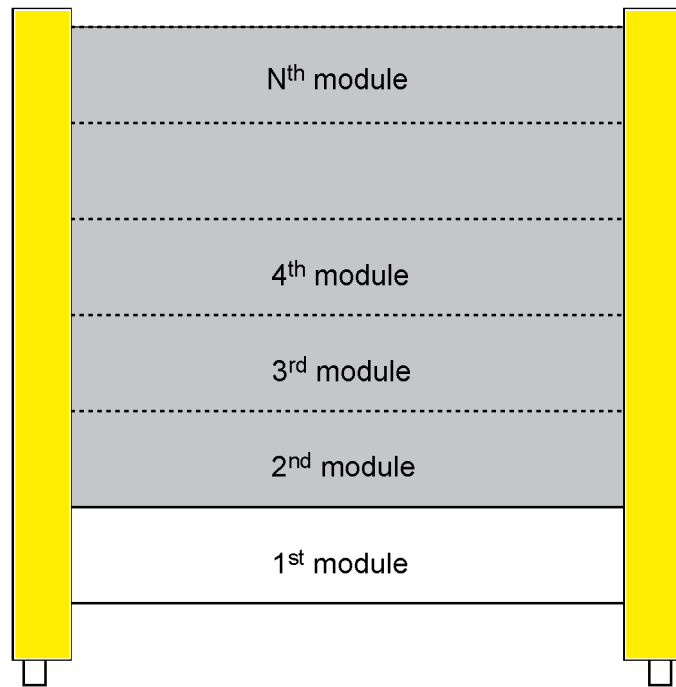

Note!

When muting a single module, the module that contains the synchronising optical beam, which is located furthest away from the M12 connector, must not be chosen. If it is, the muting function is disabled.

If muting is chosen from a module which does not exist (e.g. muting of the 4th module in a barrier that only has 3 modules, e.g. FII-4-K3-800) the muting function will not be activated, i.e. the barrier maintains protective function at all times, without muting.

If, at muting of several modules, a choice of muting modules includes one that does not exist (e.g. muting of modules 1+2+3+4 in a barrier that only has 3 modules, e.g. FII-4-K3-800) the barrier will choose muting of all existing modules.

7 Override.

- This function makes it possible to bypass the barrier completely and activate the OSSD outputs if machine start is necessary even if one or more beams are interrupted.
- This possibility is included in all Focus II barriers. This function is only possible when the muting indicator is connected and if at least one beam is interrupted. If e.g. a pallet during muting operation has stopped and at least one beam is interrupted after a voltage drop out, it would otherwise not be possible to restart the conveyor belt.

Note!

Make sure that the operator is able to check the entire protective field as long as override function is enabled. Failure to do so may result in serious injury.

Note!

- To start override, the Focus II must be in stop state and at least one beam must be blocked.
- If the entire protective field is free for more than 2sec. the override function is immediately stopped.
- A Test request on the TEST/RESET input will stop the override function immediately.
- Maximum timeout for override is 600sec. After this timeout, the Focus II system is restarting according to the interlock mode set by the selector switches.

At start-up:

- Switch off the power supply.
- Restore the power supply and press the test/reset ① (see 5) button after approx. 2 s but within 5 s and keep the button pressed for at least 5 s. The OSSD outputs will activate and thereby remain activated for a maximum time of 600s.
- The override function is now enabled and the LMS indicator flashes to signal that the barrier is being overridden.
- At automatic reset, the OSSD outputs remain activated.
- At manual reset, the reset button must be pressed and released again.

At operating cycle:

- One or both muting inputs must be active.
- Press and release the test/reset ① (see 5) button 3 times <1s
The OSSD outputs will be activated for >2s.

8 Pre-reset function.

Note!

The Pre-reset function is an addition to the manual reset function. It can be used, where the operator doing the reset is not able to see the entire dangerous zone. The pre-reset pushbutton must be installed in the (dangerous) zone from where the operator is able to check that nobody else is in the dangerous zone before the manual reset function is used. Failure to do so may result in serious injury.

- Pre-reset function sets the Focus II system to manual reset mode.
- Blanking function can not be selected using pre-reset function.
- Muting function can not be selected using pre-reset function.
- The time limit between pre-reset and manual reset is 8 sec.

See connection diagram in 4.6

9 Blanking.

Note!

- Use of Blanking will change the resolution of the light curtain.
Improper use of this feature can result in severe injury to personnel.
- Blanking may require an additional hard barrier guard.
- Blanking may require an increase in the safety distance.

Read the following section carefully.

A selectable number of optical beams can be obstructed at any location in the detection zone as long as the optical synchronization is maintained.

The beam opposite side to the connector end-cap is used for optical synchronization and cannot be blanked.

An object can freely float from one end of the protective field to the other without the Focus II system entering the stop state. The obstructed beams are not fixed at a single location but "float" through the detection zone. It is possible to have multiple blanked areas of different sizes.

Setting of Blanking is done by a teach-in or with BP-1 see 9.1.

Example using additional mechanical guarding:

Where

- 1 = part that permanently blocks 3 beams,
eg. a support table
- 2 = area that needs additional
mechanical guard

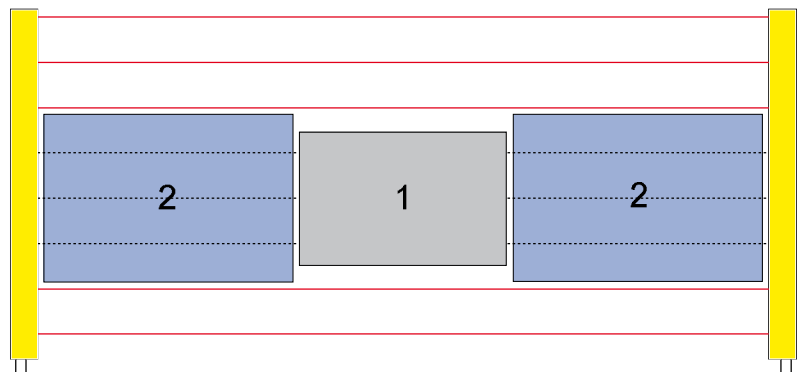

There are two limitations for the Blanking function:

1. Maximum percentage of blanked beams out of total beams is 30%
2. Maximum number of blanked beams is 21.

The Blanking function is active as long as the beams obstructed during the teach-in remain blocked. If the number of beams obstructed is higher or lower, the Focus II system will change to ERROR state with the LED 2 and 4 blinking. To reset this error, press and release the TEST/RESET pushbutton when the object is in the detection zone again.

Muting and Blanking function can be used in combination with T and L muting configuration.

Name	Tolerance	Resolution	
		FII-x-14-yyyy	FII-x-30-yyyy
Blanking ± 1	Pattern ± 1 beam	28	60
Blanking + 1	Pattern + 1 beam	21	45
Blanking ± 0	Pattern	14	30

Note!

Clearly mark, the new resolution on all labels (4pcs) of the Focus II system after setting the blanking mode, with a permanent marker pen as shown on picture below. If necessary re-calculate the safety distance.

Original

Model: FRII-4-30-600		
Type: 4	Resolution: (mm) 30	Prot. height: (mm) 6
Range: S 0,2-07m, L 07-15m		

Changed

Model: FRII-4-30-600		
Type: 4	Resolution: (mm) 60 	Prot. height: (mm) 6
Range: S 0,2-07m, L 07-15m		

9.1 Programming of Blanking.

The blanking of material in the protection area is programmed as follows:

1. Switch off the barrier's power supply.
2. Place the object to be detected for blanking purposes in the optical field.
3. Select the switches see 4.4 required for the mode of blanking by looking at the table in 9.
4. Connect the MUTING A (green) input.
The test/reset ① (see 5) contact must be closed.
5. Restore the barrier's power supply (to the receiver).
6. Supply the MUTING B (yellow) input with 24 VDC.
7. The barrier signals successful memorisation of the object in the optical field by the flashing of the LED 5 in the receiver, confirming the acceptance of blanking. If the LED does not flash at this point, it means that the object takes up an amount of optical beams which exceeds 21 beams or 30% of the total number of beams in the barrier. Blanking is then not allowed.
8. Disconnect the MUTING A and MUTING B inputs from 24 VDC.
9. The barrier works normally and signals blanking operation by the flashing of the LED 5.
10. Muting of all free beams is now possible regardless of the position of the switches (1-3) as long as a muting indicator is connected.

Blanking Programmer BP-1

Facilitates programming of selected blanking operation, especially if the extension of the object in the optical field changes every now and then. The unit is connected via M12 connectors in series, with the cable to the Focus receiver unit.

The procedure is as follows:

1. Disconnect the cable to the receiver and connect it instead to the bottom M12 connector of BP-1.
2. Connect the short cable from the top M12 con. of BP-1 to the receiver unit.
3. Place the object to be detected for blanking purposes in the optical field.
4. Switch on the power supply.
5. Press the blue button "Prog." of BP-1.
6. After 11 s the blue indicator is lit and programming is finished.
7. Disconnect the cable and connect it directly to the receiver unit.
Or have it connected all time.
8. Programming is finished.

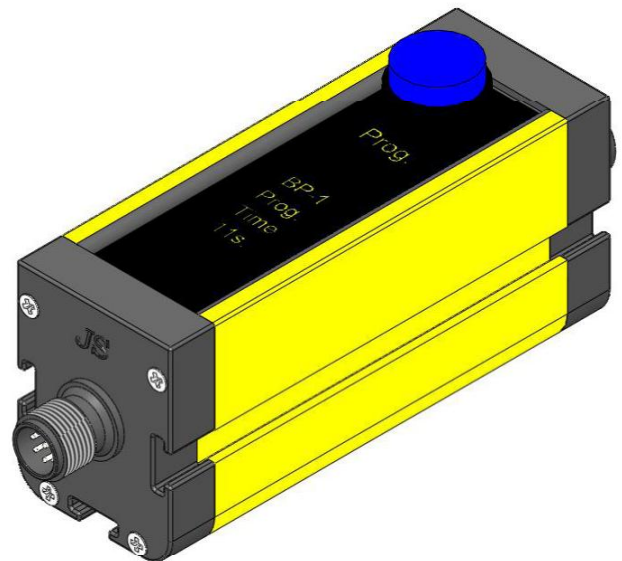

10 Single/Double Break function.

This control function can be used on small press machines where the operator is performing a loading and/or unloading cycle manually.

Wiring diagram:

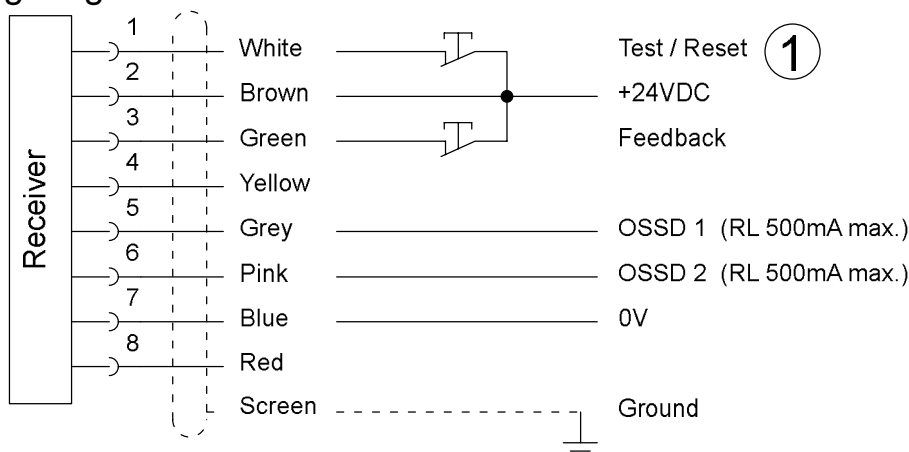

Note!

- The feedback input must be a NC contact, activated (=closed) when the machine head is in the safe position and the operator can enter the dangerous zone.
- As long as the safety outputs are ON, an additional interruption of the protective field will result in an interlock situation.

10.1 Single Break function.

The Focus II will power-up with its safety outputs off and enter the lock state if the detection zone is clear. Focus II system will enter the run state when the detection zone was entered and cleared again.

It will change to lock state automatically when one cycle of the machine is finished. The cycle can be restarted by entering and clearing the detection zone again. Each operating cycle monitored by the single break function works as follows:

- Feedback input is active (+24 V)
- Protective field is interrupted and free again (load or unload manually)
- Safety outputs enter run state and machine operates
- While machine operation the feedback input is inactive (0 V)
- When end position is reached, feedback input is active (24 V) again
- Safety outputs enter stop state

Note!

A manual restart is necessary to start the single break function sequence again after power on or any other interruption of the protective field while the machine is working.

- Input from restart and/or feedback must be longer than 300 ms.
- Minimum time of interrupting the protective field is 300 ms.

10.2 Double Break function.

This operation mode is similar to single break operation except: Operator is doing a loading and an unloading cycle manually. Focus II system will enter the run state when the detection zone was entered and cleared again twice.

Each operating cycle monitored by the single break function works as follows:

- Feedback input is active (+24 V)
- Protective field is interrupted and free again first time (unload)
- Protective field is interrupted and free again second time (load)
- Safety outputs enter run state and machine operates
- While machine operation the feedback input is inactive (0 V)
- When end position is reached, feedback input is active (24 V) again
- Safety outputs enter stop state

Note!

A manual restart is necessary to start the single break function sequence again after power on or any other interruption of the protective field while the machine is working.

- Input from restart and/or feedback must be longer than 300 ms.
- Minimum time of interrupting the protective field is 300 ms.
- Time between the double breaks must be between 300ms and 30 sec.

11 CUT - the devided light curtain.

The Focus II system is available at request as a cascaded light curtain which can be a MIX of 14 and/or 30 mm resolution and body protection as well as different lengths.

FII-x-C-rr1-lll/rr2-lll2.

Where:

x: 4 = type 4, 2= type 2

C = Cascaded light curtain

rr1 = resolution for the master

lll1 = length for the master

rr2 = resolution for the slave

lll2 = length for the slave

The limitations are:

- The total length can not exceed 2400mm
(14mm resolution 336beams, 30 mm resolution 128 beams)
- The interconnection cable's maximum length is 900mm

With a cascaded light curtain it is possible to monitor more than one opening in a machine with only one light curtain.

Example of cascaded light curtain with different resolutions and a total length of 900mm. (16+84 beams)

FII-4-C-30-300/14-600

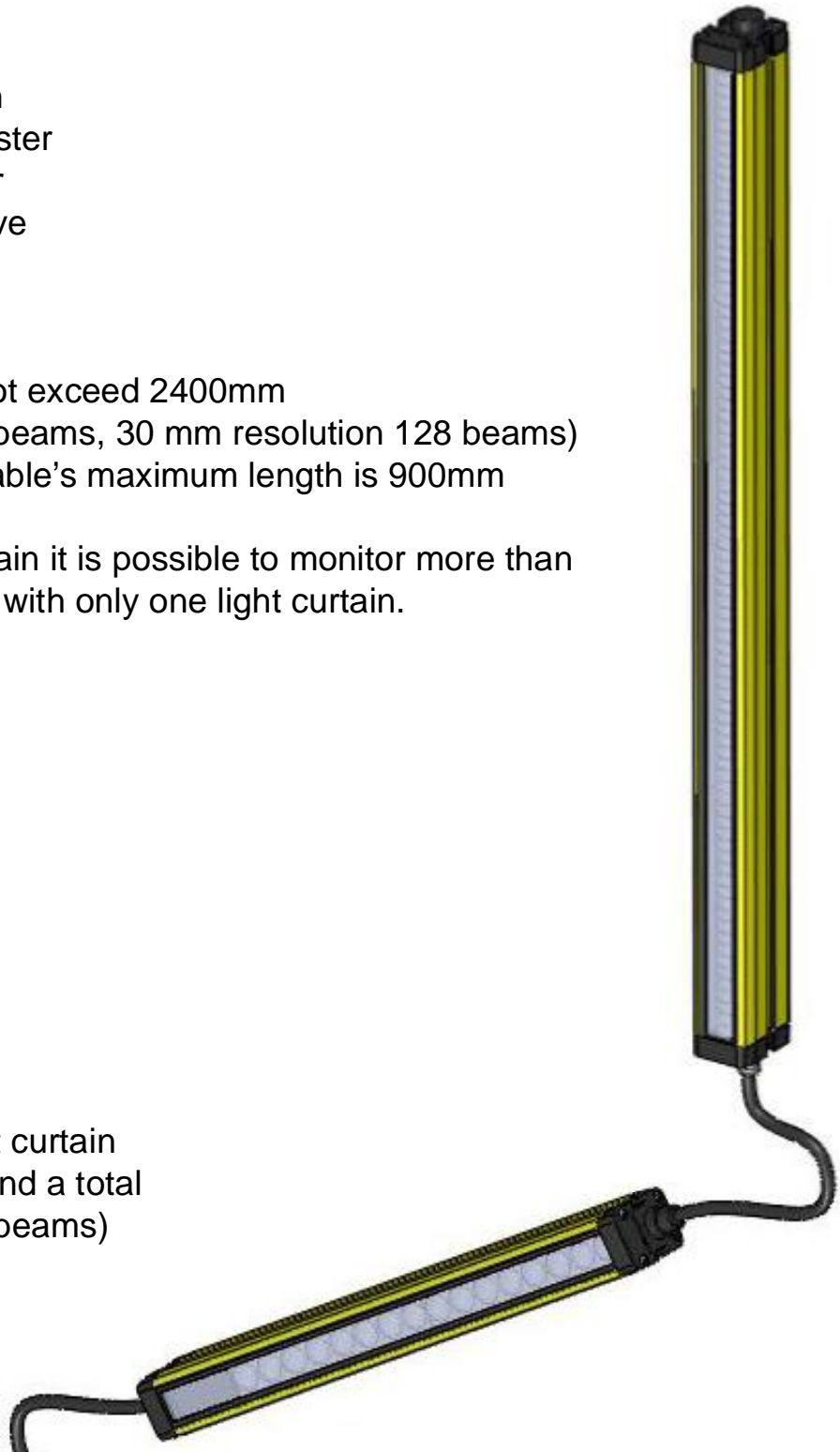

12 External Device Monitoring (EDM).

EDM is an important safety function. It monitors the Focus II system interface to the guarded machine, checks to ensure that the control elements are responding correctly to the light curtain and detects any inconsistency between the two external contactors. This is necessary to detect a malfunction within the interface.

The connection for the EDM is made at the receiver. On power-up, the Focus II system looks for a closed to +24VDC condition. If this is found, it will enter a state consistent with the

selected operating mode. When the Focus II system enables its safety outputs, it monitors the external devices for a closed to open transition. This transition must occur within 300ms or the Focus II system will then enter an alarm state.

Additionally, if the EDM connections are incorrectly wired, the system will enter an alarm state.

The EDM function can be activated and deactivated using the selector switches on the receiver unit.

Wiring diagram:

K1 and K2 are standard contactors, KM1 and KM2 are NC contacts (force guided) of K1 and K2.

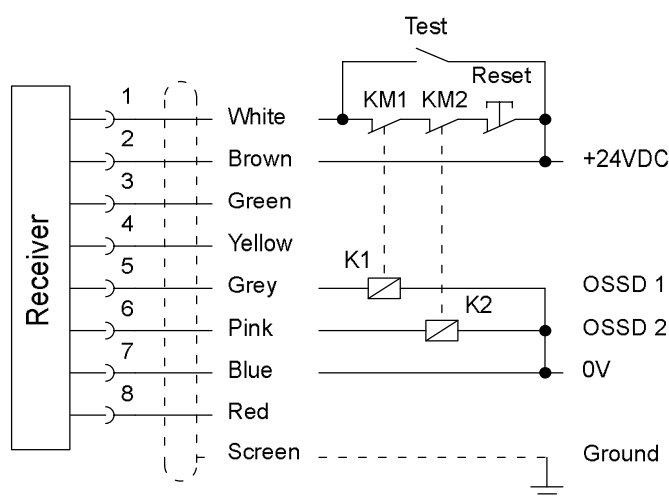

13 Checkout Procedure.

Once the Focus II system has been configured, mounted, aligned and properly connected to the machine control system, the initial Checkout Procedure (see 25) must be performed by qualified personnel. A copy of the checkout results should be kept with the machine records.

The tests outlined in the Test Procedure (see 26) must be performed at installation, according to the employer's regular inspection program and after any maintenance, tooling change set up, adjustment or modification to the Focus II system or the guarded machine. Where a guarded machine is used by multiple operators or shifts, it is suggested that the test procedure is performed at each shift or operator change. Testing ensures that the light curtain and the machine control system work properly to stop the machine. Failure to test properly could result in serious injury to personnel.

The test procedure must be performed by qualified personnel. To test the Focus II system with fixed blanking and floating blanking disabled, use the supplied test object. For applications where blanking is enabled, see the table in the chapter "Blanking" to determine the proper size of the test object.

14 Transmitter LED Information.

Normal operation

#	LED indication	Name of LED	Colour
		1	Green
		2	Yellow
		3	Green
		4 Not used	Red
		5	Yellow
	1 2 3 4 5	Description	
1	●●○○●	Normal operation, long range selected	
2	●●●○○	Normal operation, short range selected	

Error conditions

#	LED indication	Name of LED	Colour
		1	Green
		2	Yellow
		3	Green
		4 Not used	Red
		5	Yellow
	1 2 3 4 5	Description of Error	Corrective action
1	●○○○○	Low voltage	Check power supply (24VDC±20%)
2	●◐○○◑	Control logic fault	Remove and reapply power. If error is still present, contact your local JOKAB SAFETY distributor.
3	●○○○○◑	Error on range selection	Check the setting of the switches for the range selection.

15 Receiver LED Information.

Normal operation

#	LED indication	Name of LED	Colour
		1	Green
		2	Yellow
		3	Green
		4	Red
		5	Yellow
	1 2 3 4 5	Description	
1	● ○ ● ○ ○	OSSD on	
2	● ○ ○ ● ○	OSSD off	
3	● ○ ○ ● ●	Waiting for Reset	
4	● ● ● ○ ●	Alignment mode - best optical alignment	
5	● ● ● ○ ○	Short circuit on output	
6	● ○ ● ○ ◐	Special function active/status, see 4.4	
7	● ○ ○ ● ◐	Floating Blanking active, object in protected field	

If a special function like pre-reset or single/double break is active, the LED 5 uses blink codes to display the status.

- 1 flash per second: Pre-reset mode active
- 2 flashes per second: Waiting for Restart on single/double break function
- 3 flashes per second: Normal operation of single/double break function

Error conditions

#	LED indication	Name of LED	Colour
		1	Green
		2	Yellow
		3	Green
		4	Red
		5	Yellow
	1 2 3 4 5	Description of Error	Corrective action
1	●○○○○○	Low voltage	Check power supply (24VDC±20%)
2	●●○○○	Control logic fault	Remove an reapply power. If error is still present, contact your local JOKAB SAFETY distributor.
3	●●○○○	Error on safety outputs	Check wiring of the OSSD outputs.
4	●●○○○	Muting lamp connection fault or defective	Check the connection of the muting lamp and/or check condition of the muting lamp.
5	●●○○○	Mutual light interference	Check the presence of ambient light sources close to the protection field. Use coding option or remove the light source.
6	●●○○○	Error i floating blanking mode. Object not present.	Check the position of the blanking object. Make sure it is inside the blanking area.
7	●●○○○	EDM fault	Check and correct EDM wiring.
8	●○○○○○	Error in pre-reset mode	Pre-reset condition was not met. Correct placement of the pre-reset switch to keep timing within the specification.

16 Regular checkout and test.

Note!

Make sure that following checkout and test routines are carried out on a regular base. Failure to test properly could result in serious injury to personnel.

All tests must be performed by qualified personnel. A copy of the checkout results should be kept with the machine records.

How often the checks above must be done depends on the environment and the individual conditions where the barrier is assembled.

All relevant local and national rules must be adhered to when estimating the required frequency of checks. In case there is any doubt, a local or national safety organisation should be consulted.

Repeat Tests 1 and 2 on a daily base. Repeat Tests 1 to 6 at least every six months. Failure to test properly could result in serious injury to personnel.

1. Guide the test object through the entire protective field approximately in the middle of, and 1m from the front of transmitter / receiver with the appropriate size of the tool, thin side for the 14mm resolution and the thicker side for 30mm resolution. Check that in:
Manual reset; The outputs of the Focus II system remain in the OFF state and the red LED 4 is lit during the entire test and yellow LED 5 is lit when test tool is removed.
Automatic reset; The outputs of the Focus II system remain in the OFF state and the red LED 4 is lit during the entire test.
2. Activate the TEST/RESET (>2,5s). Check that the safety outputs of the Focus II system become voltage free. The red LED (4) is lit and the machinery is stopped.
3. Check that the mounting distance of the Focus II system is equal to or greater than the minimum safe distance from the danger point.
See 3.3 and 3.4 for further information.
4. Determine that all access to the danger point not protected by the Focus II system is guarded by other means, such as gates, fencing or other approved methods. Verify that all additional guarding devices are installed and operating properly.
5. Make sure the operator is not able to stand between the Focus II system detection zone and the machine danger point. Verify that the light curtain can only be reset from a position outside and within view of the hazardous machine area.
6. Inspect the electrical connections between the guarded machine's control system and the Focus II system. Verify that they are properly connected, and not damaged, to the machine so that a stop signal from the Focus II system results in an immediate halt of the machine's cycle.

17 Technical specifications.

Performance	
Protective height	150 mm - 2400 mm
Object resolution	14 mm and 30 mm
Beam pitch (center)	7.5 mm and 18 mm
Operating range	0.2 m - 3.0 m (14 mm resolution), default 3.0 m - 6.0 m (14 mm resolution), DIP Switch option 0.2 m - 7.0 m (30 mm resolution), default 7.0 m - 14 m (30 mm resolution), DIP Switch option
Effective Aperture Angle	For FII-2-xx-yyyy: $\pm 5^\circ$ maximum, transmitter and receiver according to IEC61496-2 for distances > 3 m For FII-4-xx-yyyy: $\pm 2,5^\circ$ maximum, transmitter and receiver according to IEC61496-2 for distances > 3 m
Response time ON to OFF	Maximum: 103 ms. See 5.7 for more information
Light source	Infrared Emitting LEDs, Wavelength 880 nm Power Dissipation: ≤ 3 mW Class 1 acc. EN60825-1
Mechanical	
Housing material	Painted aluminium, yellow, RAL 1018
Front plastic material	Polycarbonate
Connector material	Polyamide 6.6
End cup material	Polycarbonate
Sealing, gasket material	EPDM
Mounting bracket material	Black powder coated stainless steel
Mounting bolt	Stainless steel M6
Wiring connectors	8 Pin Receiver and 5 Pin Transmitter
Environmental	
Enclosure rating	IP65
Operating temperature	-10°C ... +55°C
Storage temperature	-25°C ... +70°C
Relative humidity	95% maximum, non condensing
Vibration (IEC 60086-2-6)	10-70 Hz, 0,35mm, maximum on all 3 axes
Shock (IEC 60086-2-29)	30 G for 16ms, 1000 shock on all 3 axes
Electrical	
Power transmitter	24 VDC $\pm 20\%$, maximum current 70 mA
Power receiver	24 VDC $\pm 20\%$, maximum current 100 mA
Input voltage threshold	$V_{Hmin} = 17$ VDC, $V_{Lmax} = 6$ V
Test / Reset	10 mA, 24 VDC, normally closed input, >2,5 s
Muting A	10 mA, 24 VDC
Muting B	10 mA, 24 VDC
EDM	10 mA, 24 VDC
Muting lamp	50 mA min, 24 VDC

Electrical	
Safety outputs (OSSD)	Two PNP safety outputs, each sourcing 500 mA 24 VDC. Short circuit protection.
Voltage drop	< 2,3 V
Leakage current	< 1 mA
Capacitive load	< 250 nF for OSSD output
Inductive load	Please contact your local JOKAB SAFETY representative
Test pulse data	Test pulse $\leq 300 \mu\text{s}$ Test interval, response time x 0,33 Repetition, response time x 0,66
Power supply	Must meet the requirements of EN/IEC60204-1 and EN/IEC61496-1, and must guarantee safe insulation from the mains voltage in accordance with IEC60742 and be able to cover a drop of supply voltage of at least 20 ms.
Protection class (IEC 536 or VDE 106)	III
Power on delay	< 2 s
Insulation resistance	> 20 M Ω
Dielectric voltage strength	350 VAC (1 min)
Connections	
Cable length Focus II	Shielded cables: Max. 100 m, 0,4 mm ² Max. 50 m, 0,2 mm ²
Cable length Focus II Mix	Shielded cables, M12 connector 8-pin, these cables are shipped with the sensors. Maximum length is 0,9 m.
Conformity	
AOPD (ESPE)	FII-2-xx-yyyy: Type 2 acc. to EN/IEC 61496-1 and EN/IEC 61496-2 FII-4-xx-yyyy: Type 4 acc. to EN/IEC 61496-1 and EN/IEC 61496-2
Category	FII-2-xx-yyyy system is suitable for safety control systems up to category 2 acc. EN 954-1. FII-4-xx-yyyy system is suitable for safety control systems up to category 4 acc. EN 954-1.
Safety Integrity Level	Focus II system is suitable for up to SIL 3 per IEC 61508.
Performance Level (PL)	Focus II type 2 systems is suitable for safety control systems up to Performance level c acc. EN ISO 13849-1. Focus II type 4 systems is suitable for safety control systems up to Performance level e acc. EN ISO 13849-1.
Mean time to dangerous failure (MTTF _d)	450 years
PFH	$2,5 * 10^{-09}$
Proof test interval	Every 20 years

18 Accessories, cables.

Type No.	Article No.	Description
M12-C61	20-056-00	6m cable 5x0.34mm with straight M12 female connector
M12-C101	20-056-10	10m cable 5x0.34mm with straight M12 female connector
M12-C201	20-056-14	20m cable 5x0.34mm with straight M12 female connector
M12-C112	20-056-20	1m cable 5x0.34mm with straight M12 female+male
M12-C312	20-056-21	3m cable 5x0.34mm with straight M12 female+male
M12-C1012	20-056-23	10m cable 5x0.34mm with straight M12 female+male
M12-C01	20-055-10	5-pin connector female with screw connection
M12-C02	20-055-11	5-pin connector male with screw connection
C5	20-057-00	cable PVC 5x0.34mm
M12-C63	20-056-30	6m cable 8x0.34mm with straight M12 female connector
M12-C103	20-056-40	10m cable 8x0.34mm with straight M12 female connector
M12-C203	20-056-41	20m cable 8x0.34mm with straight M12 female connector
M12-C134	20-056-50	1m cable 8x0.34mm with straight M12 female+male
M12-C334	20-056-51	3m cable 8x0.34mm with straight M12 female+male
M12-C03	20-055-16	8-pin connector female with screw connection
M12-C04	20-055-17	8-pin connector male with screw connection
C8	20-057-10	cable PVC 8x0.34mm
JSM 66	22-090-10	Bracket JSM 66 with bolt kit for Fence system
JSM 66	22-090-11	Bracket JSM66 with bolt kit for Focus
JSM 66	22-090-12	Bracket JSM66 with bolt kits for Focus and Fence system
JSM 67	22-090-15	Hinge bracket in plastic
JSM 68	22-090-18	Testing tool 14/30 mm
JS AP-1	22-070-10	Adapter pin with resistance and 2 clamps
JS SP-1	22-070-00	Protection pin M12
BP-1	22-090-23	Blanking programmer
JS RL-4	20-008-03	Alignment laser

19 Spare parts.

Article No.	Description
22-090-01	Bolt M6x14 A2
22-090-02	Locknut M6 A2
22-090-04	Washer B6 A2
22-090-13	Bracket 2,5mm RF A2 Black

20 WET enclosure.

WET is a transparent enclosure for extreme washing conditions. Increases the enclosure protection class to IP68, and provides the possibility for drainage or aeration in order to avoid condensation. Specify cable length for fully assembled units at delivery.

Length incl. lid: Barrier + 66 mm
 Total length: Barrier + 152,5 mm
 Material tube: PC
 Material lid: PE
 Max. operating temperature: +55°C.

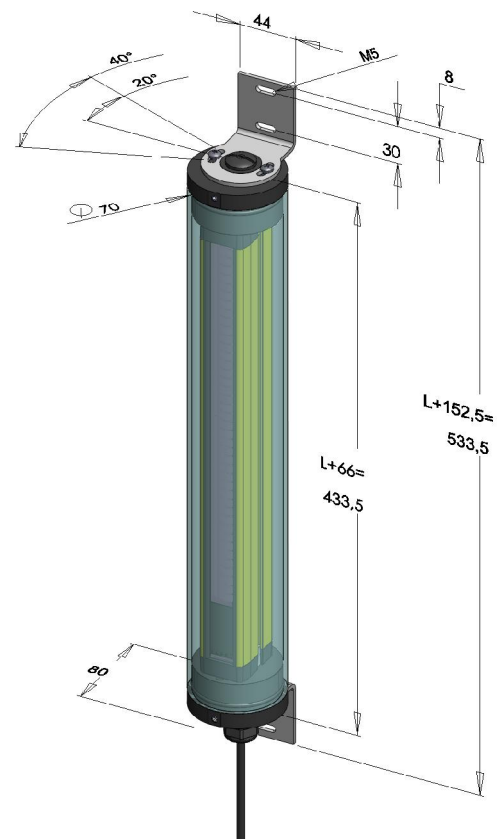

21 Bjorn - stands.

An innovation for peripheral protection application where it is necessary to protect one, two or more sides with the same barrier.

The solid structure guarantees an excellent resistance to shocks and mechanical stresses in general, supplying a comfortable protection for the safety barrier.

The adjustment of the barriers as well as of the mirror is made very easy, thanks to the presence of outer screws that can be easily reached.

The base has radius slotted holes and centre marks to ease the stand orthogonal positioning.

- H2, V2 and N2: 15 kg
- H3: 17 kg
- H4-1, H4-2: 20 kg
- N5: 27 kg
- Mirror reduction: ≤10%
- Material thickness: Metal sheet, 3mm
- Painting: Epoxy Ral 1018

H2, V2 and N2 are stock items.

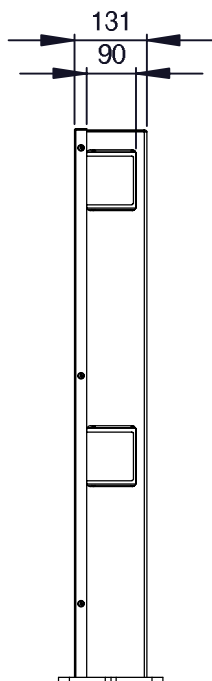
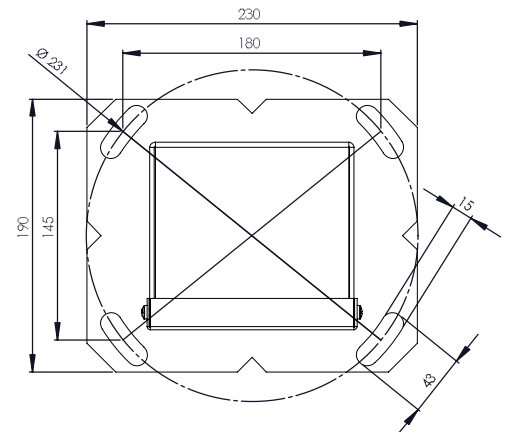

Bjorn H2
22-041-40

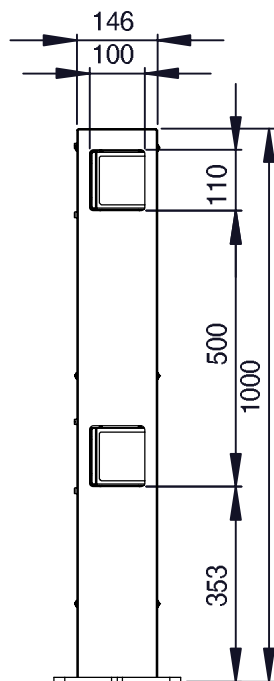

Bjorn V2
22-041-41

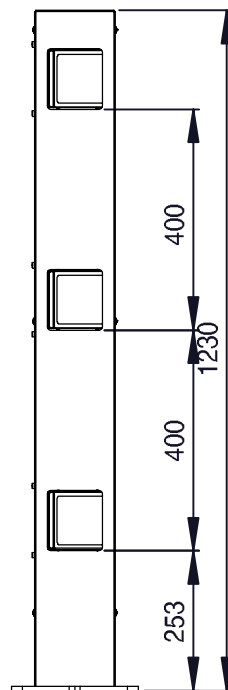

Bjorn H3
22-041-42

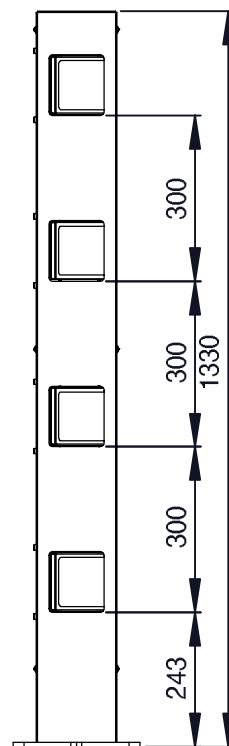

Bjorn H4-1
22-041-43

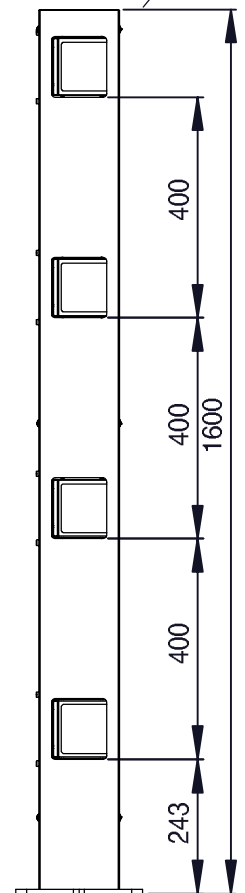

Bjorn H4-2
22-041-44

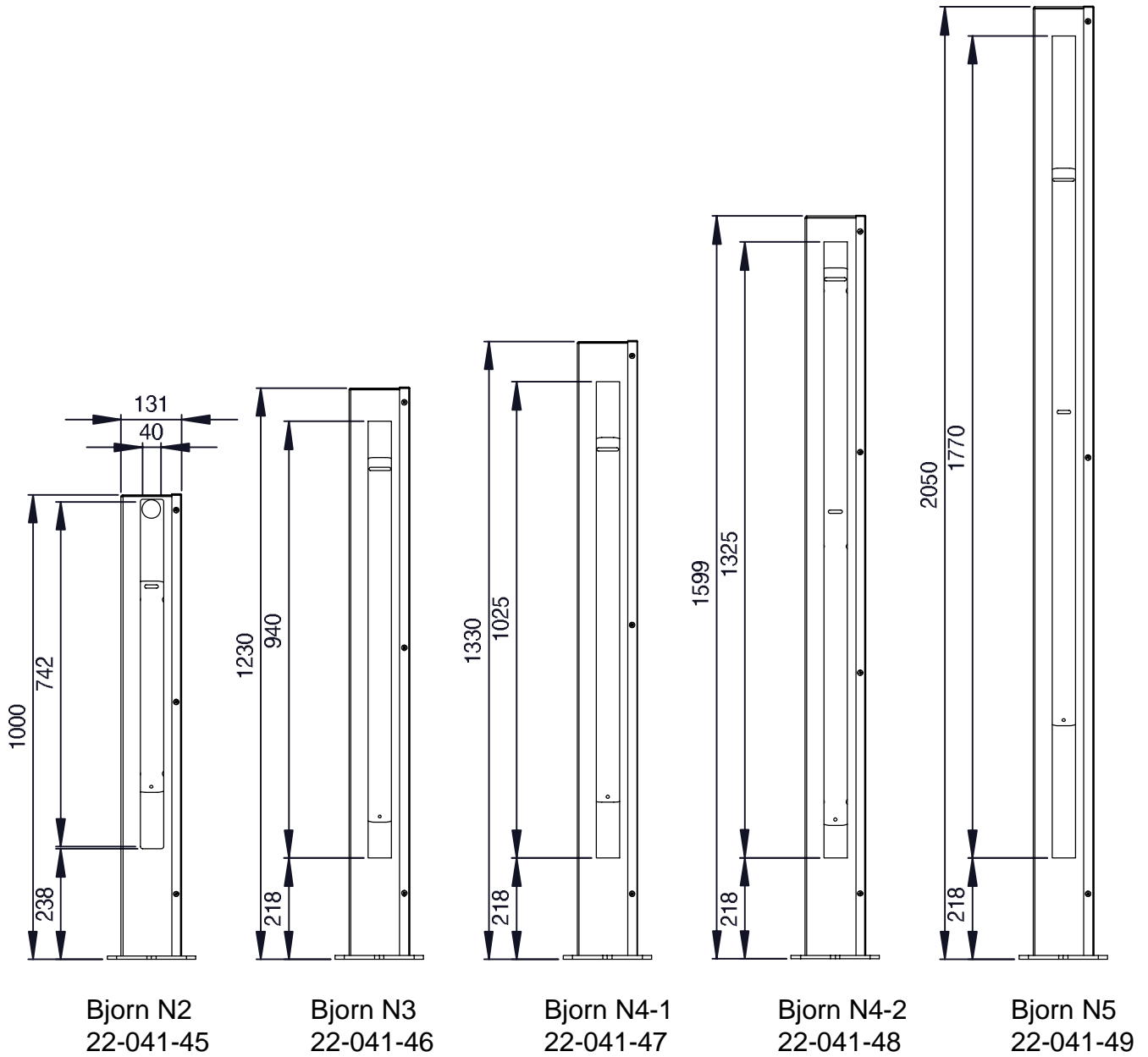

Length optimizing with the Bjorn V2 mirror stand. Comparing Standard FII-4-K1C-500 and mirror in Bjorn N2 stands to FII-4-K1C-500 with Bjorn V2 mirror stand.

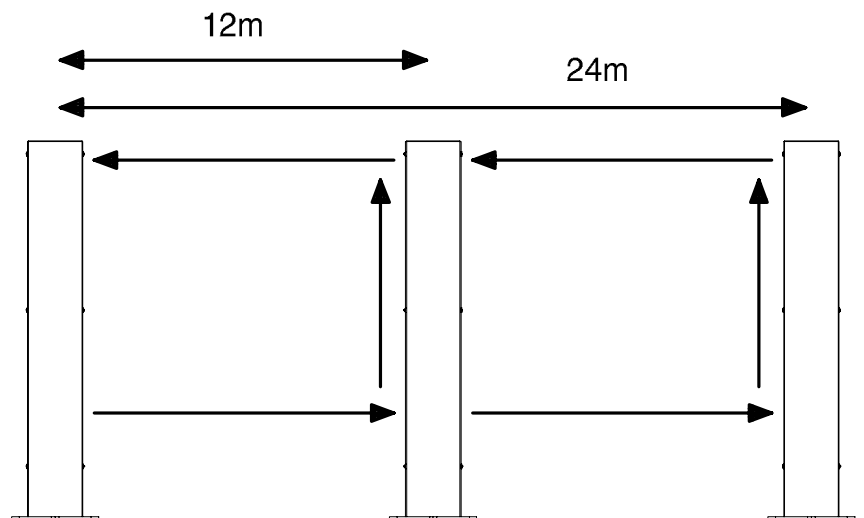

22 Dimensions of brackets and profile.

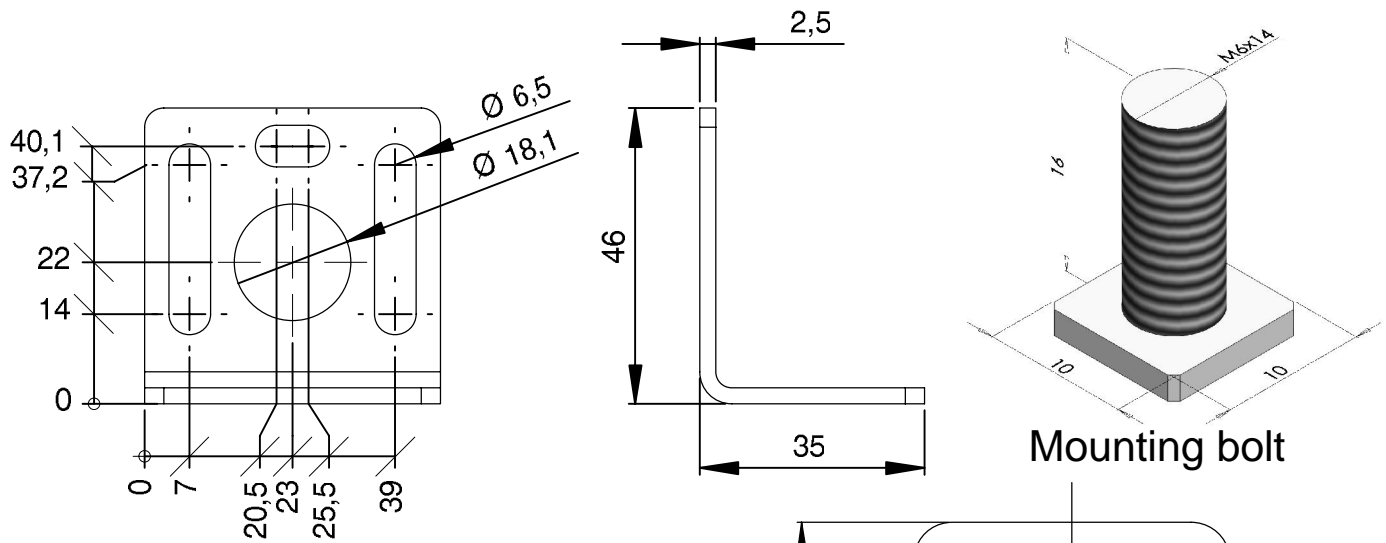

Mounting bolt

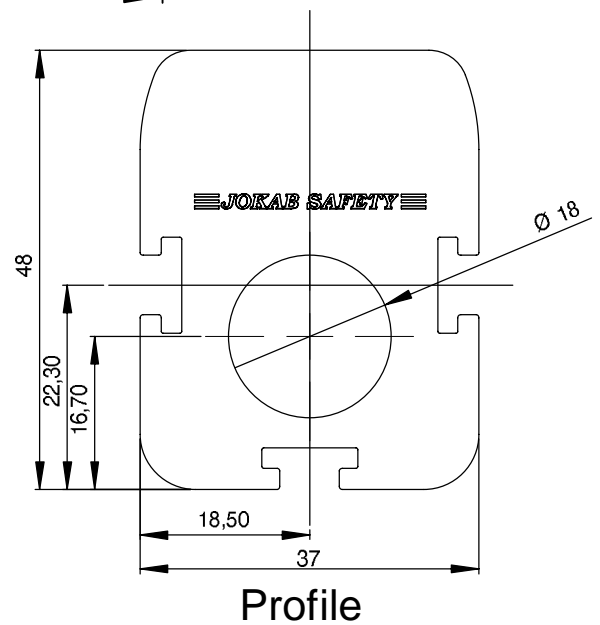
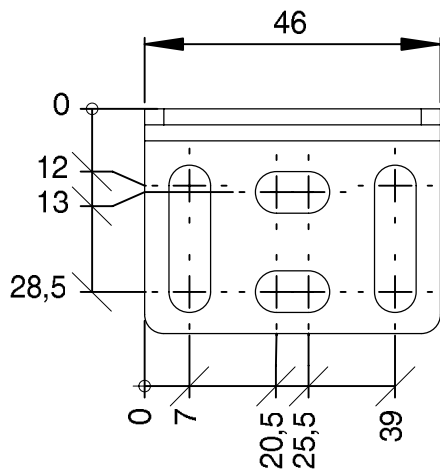

Profile

#	Article No.	Description
1	22-090-01	Mounting bolt
2	22-090-10	JSM 66
3	22-090-24	Plastic washer
4	22-090-04	Washer
5	22-090-02	Lock nut

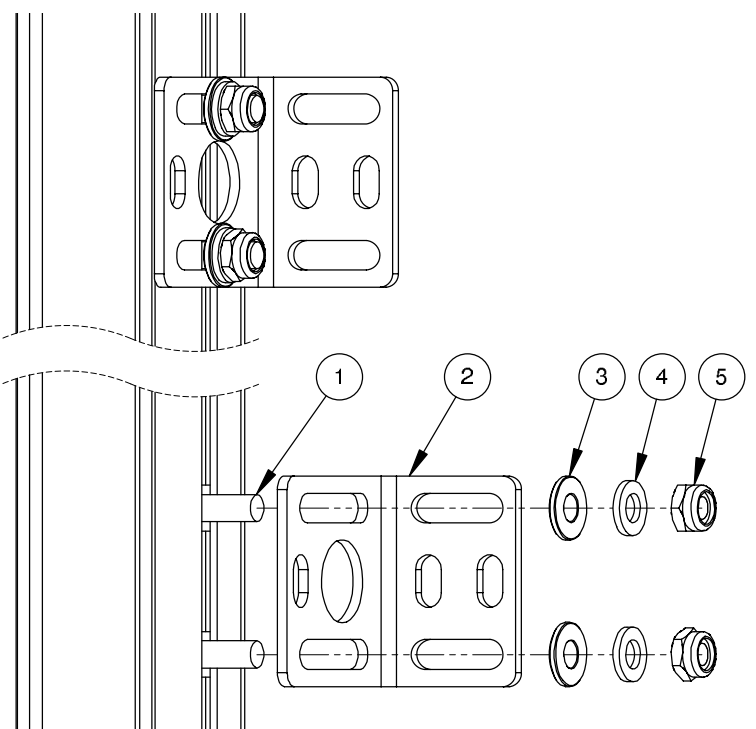

23 Dimensions of MFII mirrors and bracket.

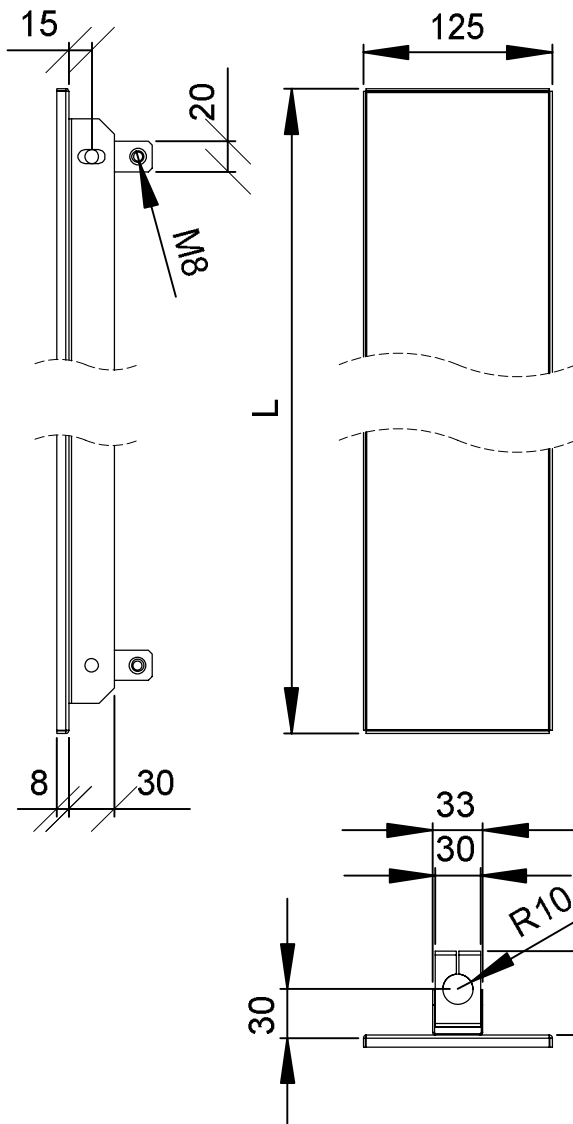

Type	Article No.	Height L
MFII-300	22-041-02	356
MFII-500	22-041-03	506
MFII-600	22-041-04	653
MFII-750	22-041-05	796
MFII-900	22-041-07	953
MFII-1050	22-041-12	1103
MFII-1200	22-041-08	1253
MFII-1350	22-041-13	1403
MFII-1500	22-041-09	1546
MFII-1650	22-041-10	1703

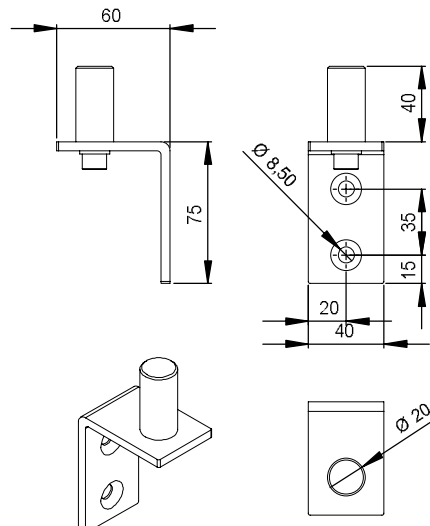

Bracket for MFII mirrors.
Article no. 22-041-20,
2 pieces for each mirror.

JSM 70, 40-001-15.
Plate for easy adjustment on uneven floors.

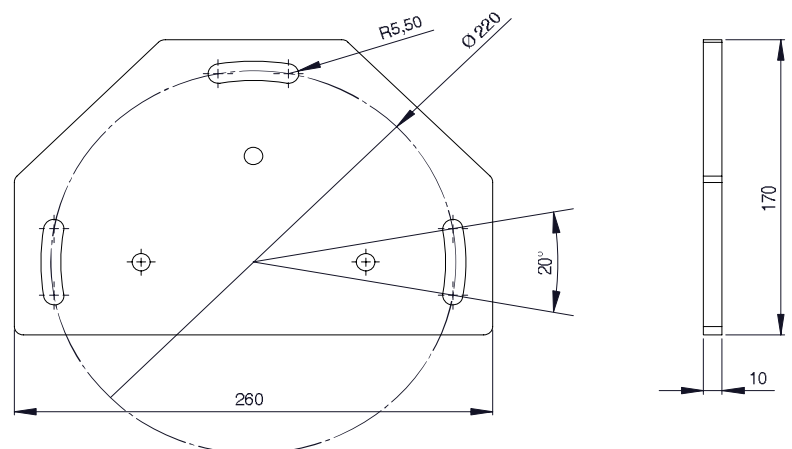
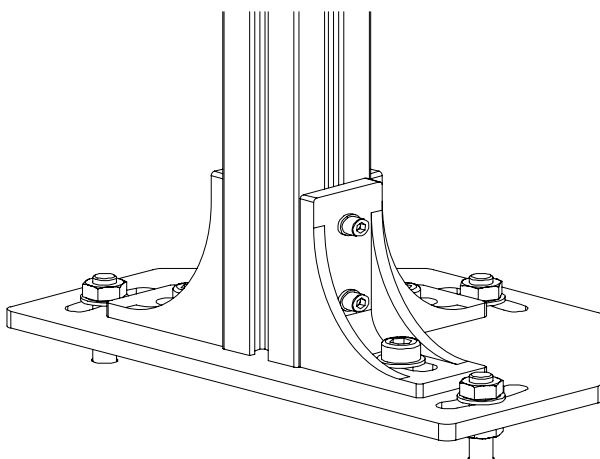

24 Variant list and general schedule.

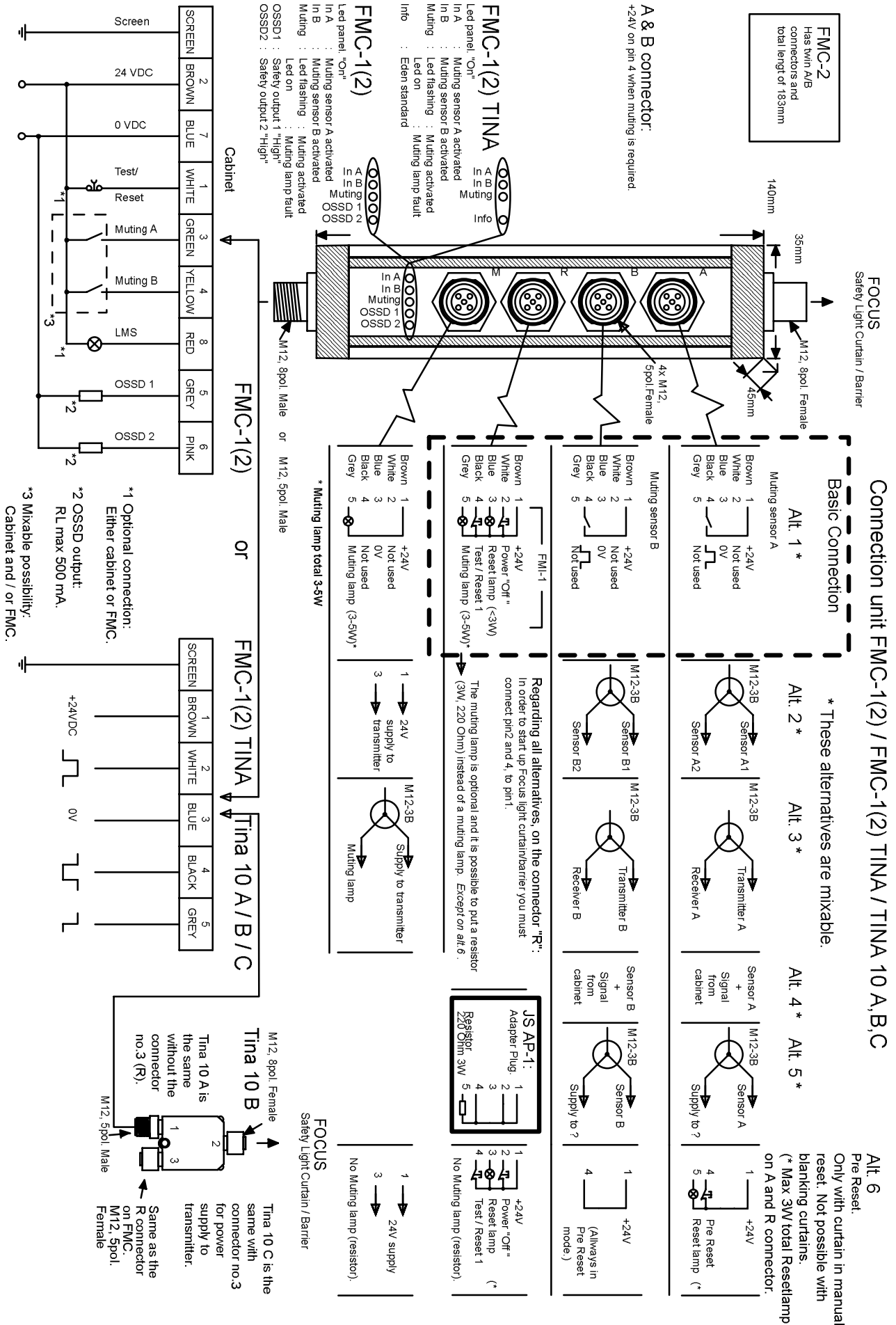

- FMC-1(2): with connectors for muting sensors (A+B), reset, power off and muting lamp (R) and muting lamp (M).
- FMI-1A: with muting lamp only.
- FMI-1B: with reset, power off and muting lamp.
- FMI-1C: with reset and power off.
- FMI-1D: with reset, power off and internal resistor for the muting lamp.
- FMI-1E: as pre reset connected to connector A (A2) on FMC-1(2) (Tina) or as reset on Tina Duo 2 connector (R).
- FMI-1G: with reset, and internal resistor for the muting lamp.
- FMC-1 (2) Tina: same as FMC-1(2) but connected to Vital or Pluto.
- Tina 10A: adaptor unit for connecting Focus to Vital or Pluto.
- Tina 10B: simplified FMC-1(2) Tina including only the connector (R).
- Tina 10C: simplified FMC-1(2) Tina including only power supply on con.no.3.
- M12-3M: bypass unit for easy connection outside the cabinet
- FRM-1A: translates the two OSSD outputs to relay outputs (and power supply).
- JS SP-1: protection plug for not used connectors.
- JS AP-1: adaptor for FMC units to use instead of FMI-1B or -1D on the (R) connector including muting resistor.

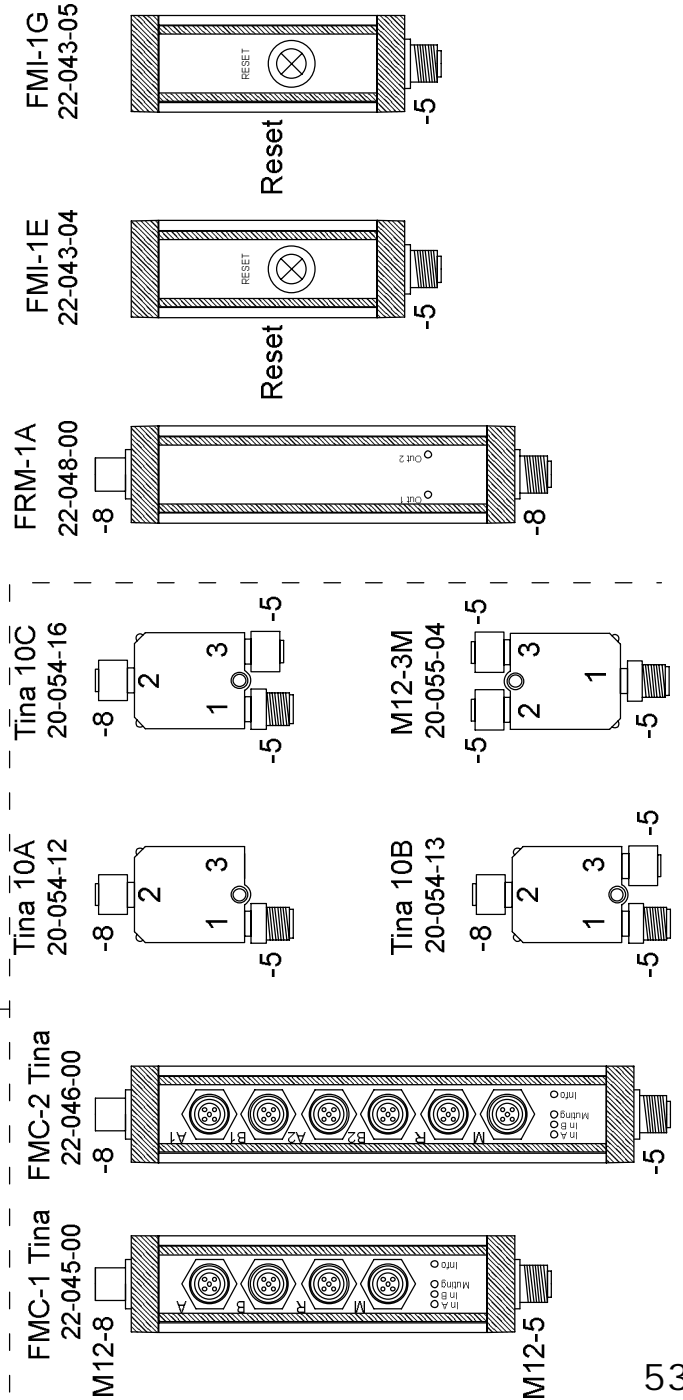
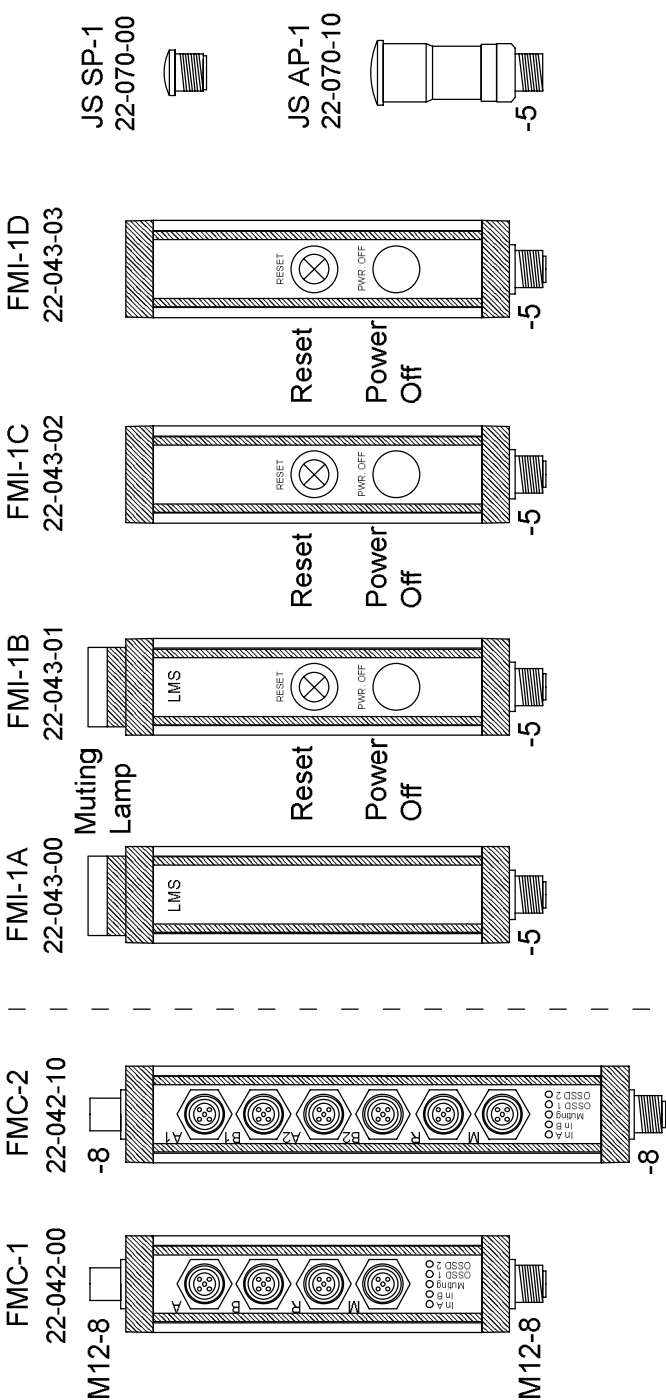

25 Checkout procedure log.

This log should be carried out at installation by qualified personnel and are recommended to use regularly according to company guidelines.

Check point	Condition	Comments
Verify that the guarded machine is compatible with the type of machine which may be used with the Focus II system.	<input type="checkbox"/> Pass <input type="checkbox"/> Fail	
Verify that the mounting distance of the Focus II system is equal to or greater than the minimum safe distance. See 3.3 or 3.4	<input type="checkbox"/> Pass <input type="checkbox"/> Fail	
Make sure that the operator is not able to stand between the Focus II system detection zone and the dangerous area. Verify that the reset button is only reachable from the safe area and that there is full view of the dangerous area.	<input type="checkbox"/> Pass <input type="checkbox"/> Fail	
Determine that all acces to the dangerous area not protected by the Focus II system is guarded by fence or similar.	<input type="checkbox"/> Pass <input type="checkbox"/> Fail	
Inspect the electrical installation between the machine control system and the Focus II system. Verify that they are connected correct and that the machine stop's when the detection zone is interrupted.	<input type="checkbox"/> Pass <input type="checkbox"/> Fail	
If EDM is used check that the wiring are correct and fully functional.	<input type="checkbox"/> Pass <input type="checkbox"/> Fail	
Record the test result in the machine log, then perform the test procedure.	<input type="checkbox"/> Pass <input type="checkbox"/> Fail	

Date and Signature:

26 Test procedure log.

Check point	Condition	Comments
Disable the guarded machine. Apply power to the Focus II system, check that LED 1 and 3 are lit on the receiver.	<input type="checkbox"/> Pass	
	<input type="checkbox"/> Fail	
Visually inspect the machine to ensure that access to the dangerous area is only through the Focus II system.	<input type="checkbox"/> Pass	
	<input type="checkbox"/> Fail	
Verify that the mounting distance of the Focus II system is equal to or greater than the minimum safe distance. See 3.3 or 3.4	<input type="checkbox"/> Pass	
	<input type="checkbox"/> Fail	
Check for signs of damage in the Focus II system installation, the cables and wiring. If something is damaged, secure the machine and report.	<input type="checkbox"/> Pass	
	<input type="checkbox"/> Fail	
Interrupt the Focus II system detection zone with the supplied test tool. See 16	<input type="checkbox"/> Pass	
	<input type="checkbox"/> Fail	
Start the machine. Check that the machine stops when the test tool is inserted to the detection zone, and it is not possible to restart when the test tool is in the detection zone.	<input type="checkbox"/> Pass	
	<input type="checkbox"/> Fail	
Verify that the safety system is stopping the machine fast enough otherwise adjust or increase the safe distance.	<input type="checkbox"/> Pass	
	<input type="checkbox"/> Fail	
If the safety devices on the machine fail any of these tests, Secure machine and report.	<input type="checkbox"/> Pass	
	<input type="checkbox"/> Fail	

Date and Signature:

JOKAB SAFETY AB

Malmö +46 (0) 40-671 56 00
Kungsbacka +46 (0) 300-67 59 00
Jönköping +46 (0) 36-37 04 60
Stockholm +46 (0) 8-544 707 40
Västerås +46 (0) 21-81 44 30

www.jokabsafety.com
 e-mail: info@jokabsafety.com

Australia:	Sensorplex Pty Ltd	+61 3 95 61 70 99
Austria:	Contra GmbH	+43 1 278 25 55
Brasil:	JOKAB SAFETY div. of ABG	+55 41 3643 1384
Canada:	NCC Electronics LTD	+1 519 735 1106
Czech Republic:	Contra spol. s.r.o.	+420 5 43 210 046
China:	JOKAB SAFETY	+86 21 613 242 77
Corea:	Hanlim Auto CO. Ltd	+82 2 2639 8567 / 8
Denmark:	JOKAB SAFETY DK A/S	+45 44 34 14 54
Finland:	JUHA-ELEKTRO OY	+358 9 478 411
France:	JOKAB SAFETY (F) SAS	+33 4 75 81 01 02
Germany:	JOKAB SAFETY (D) GmbH	+49 7424 95865 0
	Köln: DEBRA	+49 2234 788 98
Great Britain:	JOKAB SAFETY (UK) Ltd	+44 1908 26 15 95
Holland:	Isolectra B.V	+31 10 28 55 285
Ireland:	Pressure Hydraulics Ltd	+353 59 914 36 01
Italy:	JOKAB SAFETY Italia S.R.L	+39 39 688 01 34
Norway:	Automasjon og sikkerhet AS	+47 33 01 52 20
Poland:	Contra Sp. z.o.o.	+48 33 857 53 44
Portugal:	Prosistav Ida	+351 234 397 210
Singapore / Malaysia:	PICS TECHNOLOGIES	+65 6744 8018
Slovakia:	LUCOB spol.s.r.o	+421 2 432 921 77
Slovenia:	Kolektor Synatec d.o.o.	+386 5 372 06 50
Spain:	EUROTECH SYSTEMS, S.L.	+34 93 634 0101
Switzerland:	Mattle Industrieprodukte AG	+41 44 938 13 33
Turkey:	S-MIKRON E.E.S.T. Ltd Sti	+90 224 443 52 33
USA/Mexico:	JOKAB SAFETY NA	+1 734 595 6087



Ergonomical two-handed controls with two Safe-balls for protection at machines.

Complete programme with key- and contact-free breakers for gates and openings.

Pluto safety PLC.

Light barriers for several applications.

Light grid protection for dangerous machinery with supervised reset and override function.

Access device for testing and trouble shooting. Several variants for assembly in panels, programming units, etc.

Complete programme with safety relays.

Stable and easily assembled railing system of aluminium. Quick system solutions with our computer programme SafeCAD.

Terminal strips in optional lengths and measures. Bumpers and contact mats in special and standard measures.

≡ JOKAB SAFETY ≡

A MEMBER OF THE ABB GROUP