

Sho-Rate™ "50" Model 1350E and Sho-Rate™ "150" Model 1355E Sizes 2-6

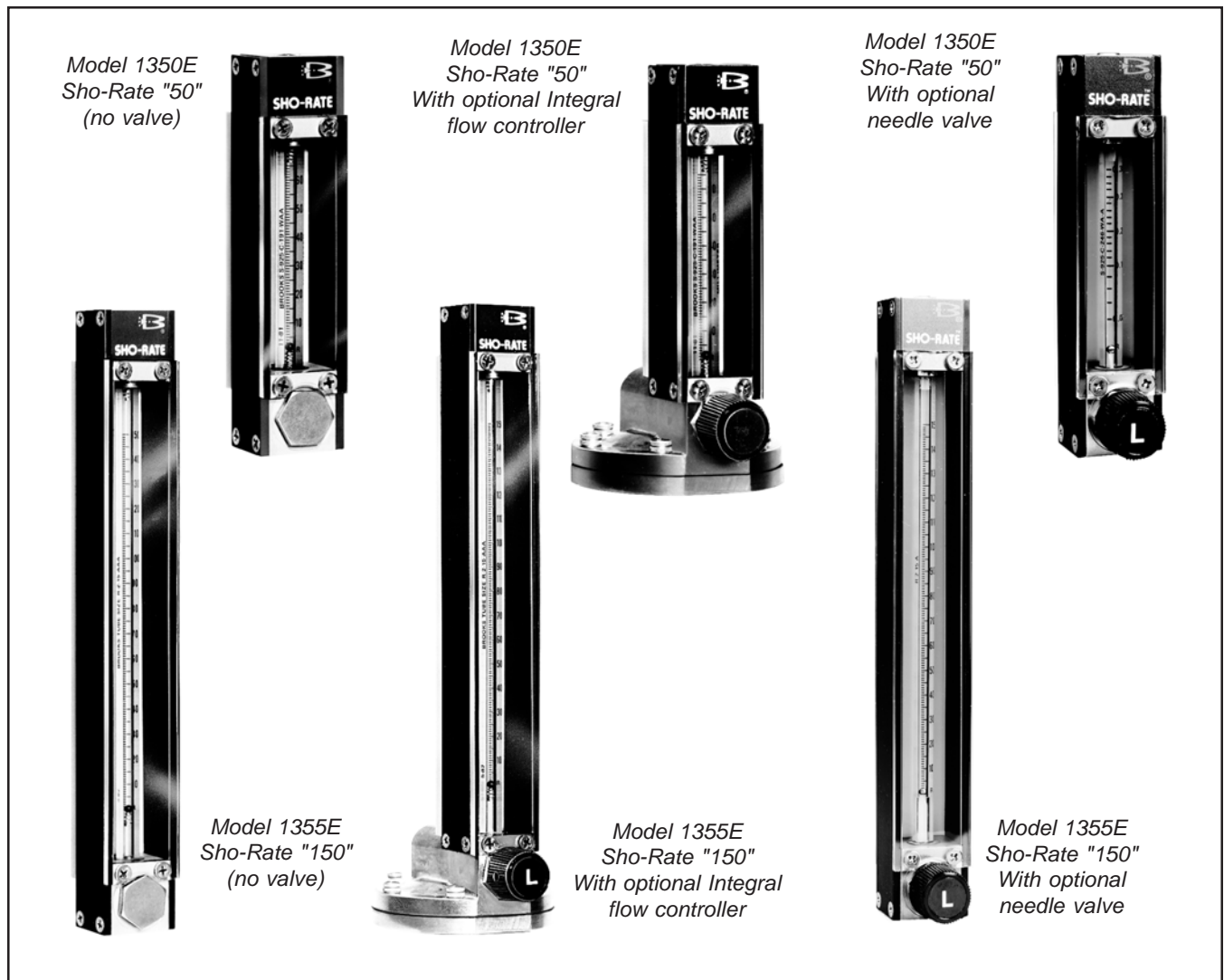

Essential Instructions

Read this page before proceeding!

Brooks Instrument designs, manufactures and tests its products to meet many national and international standards. Because these instruments are sophisticated technical products, you must properly install, use and maintain them to ensure they continue to operate within their normal specifications. The following instructions must be adhered to and integrated into your safety program when installing, using and maintaining Brooks Products.

- Read all instructions prior to installing, operating and servicing the product. If this instruction manual is not the correct manual, please see back cover for local sales office contact information. Save this instruction manual for future reference.
- If you do not understand any of the instructions, contact your Brooks Instrument representative for clarification.
- Follow all warnings, cautions and instructions marked on and supplied with the product.
- Inform and educate your personnel in the proper installation, operation and maintenance of the product.
- Install your equipment as specified in the installation instructions of the appropriate instruction manual and per applicable local and national codes. Connect all products to the proper electrical and pressure sources.
- To ensure proper performance, use qualified personnel to install, operate, update, program and maintain the product.
- When replacement parts are required, ensure that qualified people use replacement parts specified by Brooks Instrument. Unauthorized parts and procedures can affect the product's performance and place the safe operation of your process at risk. Look-alike substitutions may result in fire, electrical hazards or improper operation.
- Ensure that all equipment doors are closed and protective covers are in place, except when maintenance is being performed by qualified persons, to prevent electrical shock and personal injury.

Pressure Equipment Directive (PED)

All pressure equipment with an internal pressure greater than 0.5 bar (g) and a size larger than 25mm or 1" (inch) falls under the Pressure Equipment Directive (PED). The Directive is applicable within the European Economic Area (EU plus Norway, Iceland and Liechtenstein). Pressure equipment can be traded freely within this area once the PED has been complied with.

- Section 1 of this manual contains important safety and operating instructions related to the PED directive.
- Meters described in this manual are in compliance with EN directive 97/23/EC module H *Conformity Assessment*.
- All Brooks Instrument Flowmeters fall under fluid group 1.
- Meters larger than 25mm or 1" (inch) are in compliance with category I, II, III of PED.
- Meters of 25mm or 1" (inch) or smaller are Sound Engineering Practice (SEP).

Installation and Operation Manual

X-VA-1350E-eng

Part Number: 541B082AAG

April, 2009

Models 1350E and 1355E

Dear Customer,

We appreciate this opportunity to service your flow measurement and control requirements with a Brooks Instrument device. Every day, flow customers all over the world turn to Brooks Instrument for solutions to their gas and liquid low-flow applications. Brooks provides an array of flow measurement and control products for various industries from biopharmaceuticals, oil and gas, fuel cell research and chemicals, to medical devices, analytical instrumentation, semiconductor manufacturing, and more.

The Brooks product you have just received is of the highest quality available, offering superior performance, reliability and value to the user. It is designed with the ever changing process conditions, accuracy requirements and hostile process environments in mind to provide you with a lifetime of dependable service.

We recommend that you read this manual in its entirety. Should you require any additional information concerning Brooks products and services, please contact your local Brooks Sales and Service Office listed on the back cover of this manual or visit www.BrooksInstrument.com

Yours sincerely,

Brooks Instrument

*THIS PAGE WAS
INTENTIONALLY
LEFT BLANK*

Section 1 Introduction

<u>Paragraph Number</u>	<u>Page Number</u>
1-1 Description	1-1
1-2 Specifications	1-1
1-3 Optional Equipment	1-5

Section 2 Installation

<u>Paragraph Number</u>	<u>Page Number</u>
2-1 Receipt of Equipment	2-1
2-2 Unpacking	2-1
2-3 Return Shipment	2-2
2-4 Recommended Storage Practice	2-2
2-5 Installation	2-3

Section 3 Operation

<u>Paragraph Number</u>	<u>Page Number</u>
3-1 Operation	3-1

Section 4 Maintenance

<u>Paragraph Number</u>	<u>Page Number</u>
4-1 Disassembly & Cleaning	4-1
4-2 Reassembly procedure	4-1

Section 5 Parts List

<u>Paragraph Number</u>	<u>Page Number</u>
5-1 General	5-1

Figures

<u>Figure Number</u>	<u>Page Number</u>
2-1 Typical Flowmeter Installation	2-3
2-2 Dimensions - Sho-Rate 1350E	2-4
2-3 Dimensions - Sho-Rate 1350E and 1355E with Integral Controller	2-5
2-4 Dimensions - Sho-Rate 1355E	2-6
5-1 Parts Drawing Sho-Rate Models 1350E and 1355E	5-2

Tables

<u>Table Number</u>	<u>Page Number</u>
1-1 Capacities for Sho-Rate Model 1350E Rib Guided Tubes, Spherical Floats	1-3
1-2 Capacities for Sho-Rate Model 1350E Plain Tapered Tube, Spherical Floats	1-3
1-3 Tube and Float Code, Detachable Scale Option, 1st Digit	1-4
1-4 Tube and Float Code, Detachable Scale Option, 2nd & 3rd Digits	1-4
1-5 Capacities for Sho-Rate Model 1355E Rib Guided Tubes, Spherical Floats	1-4
5-1 Parts List - Sho-Rate Models 1350E and 1355E	5-3

Models 1350E and 1355E

*THIS PAGE WAS
INTENTIONALLY
LEFT BLANK*

1-1 Description

The Sho-Rate Flowmeters are variable area, glass tube, flow rate indicating meters. The basic elements are a tapered glass metering tube and a metering float. Features include quick and simple removal or installation of the tube and float while the meter remains in the process piping.

1-2 Specifications

WARNING

Do not operate this instrument in excess of the specifications listed below. Failure to heed this warning can result in serious personal injury and/or damage to the equipment.

WARNING

Glass metering tubes are designed for operation up to the maximum operating pressures and temperatures as specified herein. Due to the inherent brittle characteristics of glass and conditions beyond our control, tube breakage could result even within specified operating conditions. Do not use glass tube meters with fluids that are toxic, or chemically react with glass such as water above 140° F, steam, alkalis, fluorine, hydrofluoric acid, or molten metal. Failure to heed warning can result in serious personal injury and/or damage to the equipment.

Capacities

1350 Series: Refer to Tables 1-1 or 1-2, or 1-3 and 1-4

1355 Series: Refer to Tables 1-3 and 1-4, or 1-5

Accuracy

1350 Series Standard: Accuracy of $\pm 10\%$ of full scale from 100% to 10% of scale reading

1355 Series Standard: $\pm 5\%$ of full scale from 100% to 10% of scale reading

Repeatability

0.5% full scale

Rangeability

10 to 1

Pressure

200 psig at temperatures up to 250°F

Pressure Drop

Inquire at factory

Flow Meter Assembly

Pressure Equipment Directive (97/23/EC)

Note: Equipment falls under Sound Engineering Practice (SEP) according to the directive.

Models 1350E and 1355E

Scales

1350 Series:

Length: 65 mm, nominal

Graduations: Standard: 0-65mm, or 0-100 linear reference scale with air or water calibration table.

1355 Series:

Length: 150mm, nominal

Graduations: Standard: 0-150 mm, or 0-100 linear reference scale with air or water calibration table. Optional: for either 65 mm or 150 mm direct reading scale, ceramic ink fused on glass tube or metal scale plate mounted beside tube

Type: Standard: Ceramic ink fused on meter tube with contrasting yellow background

Materials of Construction

Metering Tubes: Borosilicate glass

Floats: Glass, 316 stainless steel, sapphire, Carboloy[®], tantalum

Structural Members:

End fittings: Chrome plated brass, black anodized aluminum, 316 stainless steel

Side Plates:

Standard: Black anodized aluminum

Optional: 316 stainless steel

Window: Clear polycarbonate; Back Window: Milk white polycarbonate

Float Stops:

Standard: Teflon[®]

Optional: 316 Stainless Steel

Tube Packing:

Standard: Buna-N (Brass and aluminum meters), Viton-A[®] fluoroelastomers (316 stainless steel meters)

Optional: Teflon, EPM (also known as EPR)

O-rings:

Standard: Buna-N (Brass and aluminum meters), Viton-A fluoroelastomers (316 stainless steel meters)

Optional: Teflon (not available with needle valves), EPM, Kalrez[®]

Connections

Standard: Horizontal female 1/8" NPT threaded adapters with locknuts for front of panel mounting

Multi-tube meters: Individual 1/8" NPT horizontal inlet and outlet; Manifold connection 1/8" NPT on inlet with individual outlet or manifold outlet with individual inlet connections.

Dimensions

Refer to Figures 2-2 and 2-3

Table 1-1 Capacities for Sho-Rate Model 1350E Rib Guided Tubes, Spherical Floats

METER SIZE	TUBE NO.	FLOAT MATERIAL	RIBBED TUBES, SPHERICAL FLOATS							
			MAXIMUM FLOW RATE							
			WATER				AIR*			
			GPH	CODE	LPH	CODE	SCFH	CODE	NLPH	CODE
2	R-2-65-A	GLASS	0.011	JB6	0.042	JB9	0.13	JB7	3.4	JB8
		SAPPHIRE	0.022	JC4	0.085	JC2	0.18	JC3	5.0	JC1
		STN. STL.	0.046	JC8	0.18	JC5	0.34	JC7	9.0	JC6
		CARBOLOY	0.10	JB4	0.38	JB5	0.65	JB2	17.0	JB3
		TANTALUM	0.11	JD2	0.42	JC9	0.70	JD1	19.0	JD3
	R-2-65-B	GLASS	0.013	KB8	0.048	KB2	0.15	KB7	4.0	KB9
		SAPPHIRE	0.026	KC1	0.10	KD3	0.22	KC2	5.5	KC3
		STN. STL.	0.06	KC5	0.22	KC6	0.42	KC7	11.0	KC8
		CARBOLOY	0.12	KB4	0.48	KB5	0.80	KB3	22.0	KB6
		TANTALUM	0.13	KD2	0.50	KD5	0.85	KD4	22.0	KD1
	R-2-65-C	GLASS	0.11	LB9	0.42	LB7	0.95	LB6	24.0	LB8
		SAPPHIRE	0.15	LC1	0.6	LC2	1.3	LC3	34.0	LC4
		STN. STL.	0.38	LC7	1.4	LC8	2.0	LC9	50.0	LC6
		CARBOLOY	0.65	LB3	2.4	LB2	3.0	LB4	80.0	LB5
		TANTALUM	0.65	LD1	2.6	LD2	3.2	LD3	85.0	LD4
	R-2-65-D	GLASS	0.65	MB9	2.4	MB7	3.8	MB8	100	MC1
		SAPPHIRE	0.95	MC2	3.6	MC3	5.0	MC4	130	MC5
		STN. STL.	1.60	MC7	6.0	MD1	7.5	MC6	200	MC8
		CARBOLOY	2.40	MB5	9.0	MB2	11.0	MB3	280	MB4
		TANTALUM	2.60	MD5	10.0	MD6	12.0	MD2	300	MD4
6	R-6-65-A	GLASS	2.40	NB8	8.5	NB7	13.0	NC1	340	NB9
		SAPPHIRE	3.40	NC4	13.0	NC3	17.0	NC6	460	NC5
		STN. STL.	5.50	ND1	20.0	ND3	26.0	NC9	650	ND2
		CARBOLOY	8.50	NB2	32.0	NB3	36.0	NB5	950	NB6
		TANTALUM	9.0	ND6	34.0	ND5	38.0	ND7	1000	ND4
	R-6-65-B	GLASS	8.0	PB9	30.0	PB8	44.0	PC1	1100	PB7
		SAPPHIRE	12.0	PC5	44.0	PC3	60.0	PC4	1500	PC2
		STN. STL.	19.0	PD1	70.0	PC9	85.0	PC8	2200	PC6
		CARBOLOY	28.0	PB3	100	PB2	130	PB6	3400	PB4
		TANTALUM	30.0	PD7	110	PD6	140	PD5	3600	PD4

* FLOW RATES GIVEN ARE MAXIMUM VALUES. AIR FLOWS ARE AT 14.7 PSIA AND 70 DEGREES F.

Table 1-2 Capacities for Sho-Rate Model 1350E Plain Tapered Tubes, Spherical Floats

PLAIN TAPER TUBES, SPHERICAL FLOATS								
TUBE AND FLOAT	SCFH AIR*	Press. Drop ** Inches W.C.	CODE	TUBE AND FLOAT	GPH WATER	Press. Drop ** Inches W.C.	CODE	
1-65A GLASS	1.2	1.0	AB4	1-65C GLASS	0.14	1.8	AB5	
2-65A GLASS	2.0	2.2	BA7	2-65C STN. STL.	0.5	4.0	DA5	
2-65B STN. STL.	5.0	10.8	CA4	2-65D STN. STL.	1.0	19.5	CA8	
3-65A GLASS	6.0	12.4	EB4	3-65C GLASS	0.7	22.3	EB9	
3-65B STN. STL.	10	10.1	EB8	3-65D STN. STL.	1.6	18.3	EC1	
4-65A GLASS	12	10.4	FC3	4-65C GLASS	2.0	18.7	FD3	
4-65B STN. STL.	18	25	FC8	4-65D STN. STL.	4.0	45	FD6	
5-65A GLASS	45	60	GB6	5-65C GLASS	9.0	109	GC4	
5-65B STN. STL.	80	214	GC1	5-65D STN. STL.	17	385	GC5	
6-65A GLASS	55	73	HB8	6-65C GLASS	11	132	HC7	
6-65B STN. STL.	90	292	HC5	6-65D STN. STL.	20	525	HD1	
6-65E CARBOLOY	120	400	HD3	6-65F CARBOLOY	30	890	HD4	

* FLOW RATES ARE MAXIMUM VALUES. AIR FLOWS ARE AT 14.7 PSIA AND 70 DEGREES F

** PRESSURE DROPS ARE APPROXIMATE

Models 1350E and 1355E

Table 1-3 Tube and Float Code, Detachable Scale Option, 1st Digit

CODE	MODEL 1350 TUBE	MODEL 1355 TUBE
A	1-65	R-2-15-A
B	2-65A	R-2-15-AA
C	2-65B & D	R-2-15-AAA
D	2-65C	R-2-15-B
E	3-65	R-2-15-C
F	4-65	R-2-15-D
G	5-65	R-6-15-A
H	6-65	R-6-15-B
J	R-2-65-A	
K	R-2-65-B	
L	R-2-65-C	
M	R-2-65-D	
N	R-6-65-A	
P	R-6-65-B	
Y	NO TUBE	NO TUBE

Table 1-4 Tube and Float Code, Detachable Scale Option, 2nd & 3rd Digits

METER ACCURACY	FLOAT MATERIAL	DETACHABLE SCALE INSCRIPTION				
		MM	0-100 LINEAR	SPECIAL SINGLE SCALE	SPECIAL DUAL SCALE	BLANK SCALE
STANDARD (1350-10%) (1355- 5%)	GLASS	1A	1N	2A	2N	3A
	STN. STL.	1B	1P	2B	2P	3B
	SAPPHIRE	1C	1Q	2C	2Q	3C
	CARBOLOY	1D	1R	2D	2R	3D
	TANTALUM	1E	1S	2E	2S	3E
	*ALUMINUM	1F	1T	2F	2T	3F
CALIBRATED (1350-5%) (1355-2%)	GLASS	1G	1U	2G	2U	
	STN. STL.	1H	1V	2H	2V	
	SAPPHIRE	1J	1W	2J	2W	
	CARBOLOY	1K	1X	2K	2X	
	TANTALUM	1L	1Y	2L	2Y	
	*ALUMINUM	1M	1Z	2M	2Z	
N/A	NONE	9A	9B			9C

*ALUMINUM SPOOL FLOAT FOR 15 CC/MIN AIR AVAILABLE ONLY WITH R-2-15-AAA

Table 1-5 Capacities for Sho-Rate Model 1355E Rib Guided Tubes, Spherical Floats

CAPACITIES (RIB GUIDE TUBES, SPHERICAL FLOATS) - FOR USE WITH 1355 SERIES ONLY							
METER SIZE	TUBE NO.	FLOAT MATERIAL	MAXIMUM FLOW RATE*		MODEL CODE - SCALE ON TUBE		
			WATER (CC/MIN)	AIR	0-100 LINEAR		
					0-150 MM	10-100%	0-100 LINEAR
2	R-2-15-AAA	GLASS	0.524	47.1 SCC/M	CA6		CA1
		SAPPHIRE	1.02	73.3 SCC/M	CA8		CA3
		STN. STL.	2.42	140 SCC/M	CA7		CA2
		CARBOLOY	4.77	238 SCC/M	CA9		CA4
		TANTALUM	5.31	260 SCC/M	CB1		CA5
	R-2-15-AA	GLASS	0.964	83.8 SCC/M	BA6		BA1
		SAPPHIRE	1.86	128 SCC/M	BA8		BA3
		STN. STL.	4.34	245 SCC/M	BA7		BA2
		CARBOLOY	8.37	416 SCC/M	BA9		BA4
		TANTALUM	9.30	454 SCC/M	BB1		BA5
	R-2-15-D	GLASS	5.58	361 SCC/M	FA6		FA1
		SAPPHIRE	10.2	491 SCC/M	FA8		FA3
		STN. STL.	19.8	790 SCC/M	FA7		FA2
		CARBOLOY	31.9	1170 SCC/M	FA9		FA4
		TANTALUM	34.4	1250 SCC/M	FB1	LIQ. GAS	FA5
	R-2-15-A	GLASS	16.1	0.790 SLPM	AA6	AB7 AC3	AA1
		SAPPHIRE	25.2	1.04 SLPM	AA8	AB9 AC4	AA3
		STN. STL.	44.2	1.60 SLPM	AA7	AB8 AC6	AA2
		CARBOLOY	67.7	2.32 SLPM	AA9	AC1 AC5	AA4
		TANTALUM	72.5	2.46 SLPM	AB1	AC2 AC7	AA5
	R-2-15-B	GLASS	50.6	2.25 SLPM	DA6	DB2	DA1
		SAPPHIRE	76.2	2.92 SLPM	DA8	DB4	DA3
		STN. STL.	127	4.42 SLPM	DA7	DB3	DA2
		CARBOLOY	189	6.35 SLPM	DA9	DB5	DA4
TANTALUM		202	6.74 SLPM	DB1	DB6	DA5	
R-2-15-C	GLASS	81.1	3.69 SLPM	EA6	EB2	EA1	
	SAPPHIRE	123	4.81 SLPM	EA8	EB4	EA3	
	STN. STL.	208	7.23 SLPM	EA7	EB3	EA2	
	CARBOLOY	312	10.1 SLPM	EA9	EB5	EA4	
	TANTALUM	333	10.6 SLPM	EB1	EB6	EA5	
6	R-6-15-A	GLASS	191	8.26 SLPM	GA6	GB2	GA1
		SAPPHIRE	284	10.6 SLPM	GA8	GB4	GA3
		STN. STL.	468	15.7 SLPM	GA7	GB3	GA2
		CARBOLOY	690	22.0 SLPM	GA9	GB5	GA4
		TANTALUM	735	23.3 SLPM	GB1	GB6	GA5
	R-6-15-B	GLASS	548	22.6 SLPM	HA6	HB2	HA1
		SAPPHIRE	809	28.6 SLPM	HA8	HB4	HA3
		STN. STL.	1290	41.6 SLPM	HA7	HB3	HA2
		CARBOLOY	1850	58.1 SLPM	HA9	HB5	HA4
		TANTALUM	1960	61.4 SLPM	HB1	HB6	HA5

NOTE: ALL AIR FLOWS ARE AT 14.7 PSIA AND 70 DEGREES F.

* FLOW RATES SHOWN ARE MAXIMUM CAPACITIES. DIRECT READ SCALES MAY END AT SLIGHTLY DIFFERENT MAXIMUM FLOWS.

1-3 Optional Equipment

Standard Needle Valve

The standard needle valve can be supplied integrally mounted to the inlet or outlet of the instrument. For more details on the needle valve go to our website: BrooksInstrument.com, select Documentation, Precision Valves & Flow Controllers, select Brooks-Line IV, CART, 8503 or 8504 valves.

Flow Contollers

Flow controllers can be supplied integrally mounted to the inlet or outlet of the instrument. For the flow controller's complete instruction manual go to our website: BrooksInstrument.com, select Documentation, Precision Valves & Flow Controllers, select FC8800, or FC8900.

*THIS PAGE WAS
INTENTIONALLY
LEFT BLANK*

2-1 Receipt of Equipment

When the equipment is received, the outside of the packing case should be checked for any damage incurred during shipment. If the packing case is damaged, the local carrier should be notified at once regarding his liability. Remove the envelope containing the shipping list. Carefully remove the equipment from the packing case and inspect for any damaged or missing parts.

In the event that the meter is damaged during shipment, the Product Service Department, Brooks Instrument, LLC, Hatfield, PA 19440 should be contacted to obtain a return shipment form.

Brooks Instrument

407 W. Vine Street
P.O. Box 903
Hatfield, PA 19440 USA
Toll Free (888) 554 FLOW (3569)
Tel (215) 362 3700
Fax (215) 362 3745
E-mail: BrooksAm@BrooksInstrument.com
www.BrooksInstrument.com

Brooks Instrument

Neonstraat 3
6718 WX Ede, Netherlands
P.O. Box 428
6710 BK Ede, Netherlands
Tel +31 (0) 318 549 300
Fax +31 (0) 318 549 309
E-mail: BrooksEu@BrooksInstrument.com

Brooks Instrument

1-4-4 Kitasuna Koto-Ku
Tokyo, 136-0073 Japan
Tel +81 (0) 3 5633 7100
Fax +81 (0) 3 5633 7101
Email: BrooksAs@BrooksInstrument.com

2-2 Unpacking

Carefully unpack the meter and inspect it for any damage that may have occurred during shipment. The flowmeters are shipped completely assembled and tested. It should not be necessary to tighten or adjust any of the parts when it is received.

2-3 Return Shipment

Do not return any assembly or part without a Return Materials Report. The Return Materials Report is available from all District Sales Offices and the Product Service Department, Hatfield, PA 19440. Information describing the problem, corrective action, if any, and the work to be accomplished at the factory must be included.

Brooks Instrument

407 W. Vine Street
P.O. Box 903
Hatfield, PA 19440 USA
Toll Free (888) 554 FLOW (3569)
Tel (215) 362 3700
Fax (215) 362 3745
E-mail: BrooksAm@BrooksInstrument.com
www.BrooksInstrument.com

Brooks Instrument

Neonstraat 3
6718 WX Ede, Netherlands
P.O. Box 428
6710 BK Ede, Netherlands
Tel +31 (0) 318 549 300
Fax +31 (0) 318 549 309
E-mail: BrooksEu@BrooksInstrument.com

Brooks Instrument

1-4-4 Kitasuna Koto-Ku
Tokyo, 136-0073 Japan
Tel +81 (0) 3 5633 7100
Fax +81 (0) 3 5633 7101
Email: BrooksAs@BrooksInstrument.com

2-4 Recommended Storage Practice

If intermediate or long term storage is required for equipment, as supplied by Brooks Instrument, it is recommended that said equipment be stored in accordance with the following:

- a. Within the original shipping container.
- b. Stored in a sheltered area, preferably a warm, dry heated warehouse.
- c. Ambient temperature 70°F (21.0°C) nominal 110°F maximum/45°F minimum (43°C maximum/7.1°C minimum).
- d. Relative humidity 45% nominal 60% maximum/25% minimum.

Upon removal from storage, a visual inspection should be conducted to verify the condition of equipment is "as received". If the equipment has been in storage for an excess of two (2) years or in conditions in excess of those recommended, all pressure boundary seals should be replaced and the device subject to a hydrostatic/pneumatic pressure test to 150% of rated pressure.

2-5 Installation (See Figures 2-1, 2-2, 2-3, 2-4 and 2-5)

The flowmeter should be mounted within 6° of true vertical. The inlet connection to the flowmeter is in the bottom end fitting. The connections are normally horizontal, female NPT. Be sure the piping is adequately supported to prevent undue strain on the meter.

⚠ WARNING

If the inlet and outlet valves adjacent to the flowmeter are to be closed for any reason, the flowmeter must be completely drained. Failure to do so may result in thermal expansion of the liquid which can cause rupture of the meter and possible personal injury.

⚠ CAUTION

Care must be taken in the system piping to this instrument to prevent sudden excessive pressure or flow surges. Protective devices should be installed upstream from this instrument, such as flow controllers, pressure regulators, pressure snubbers and rupture discs.

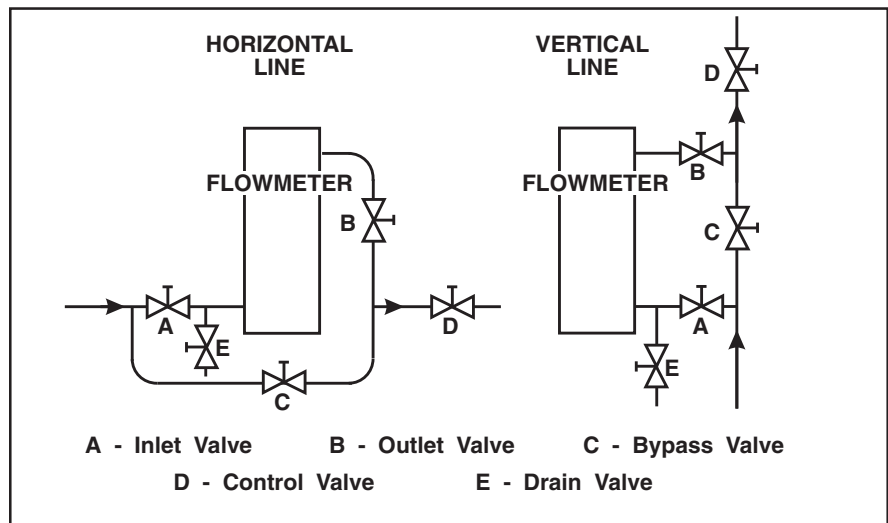
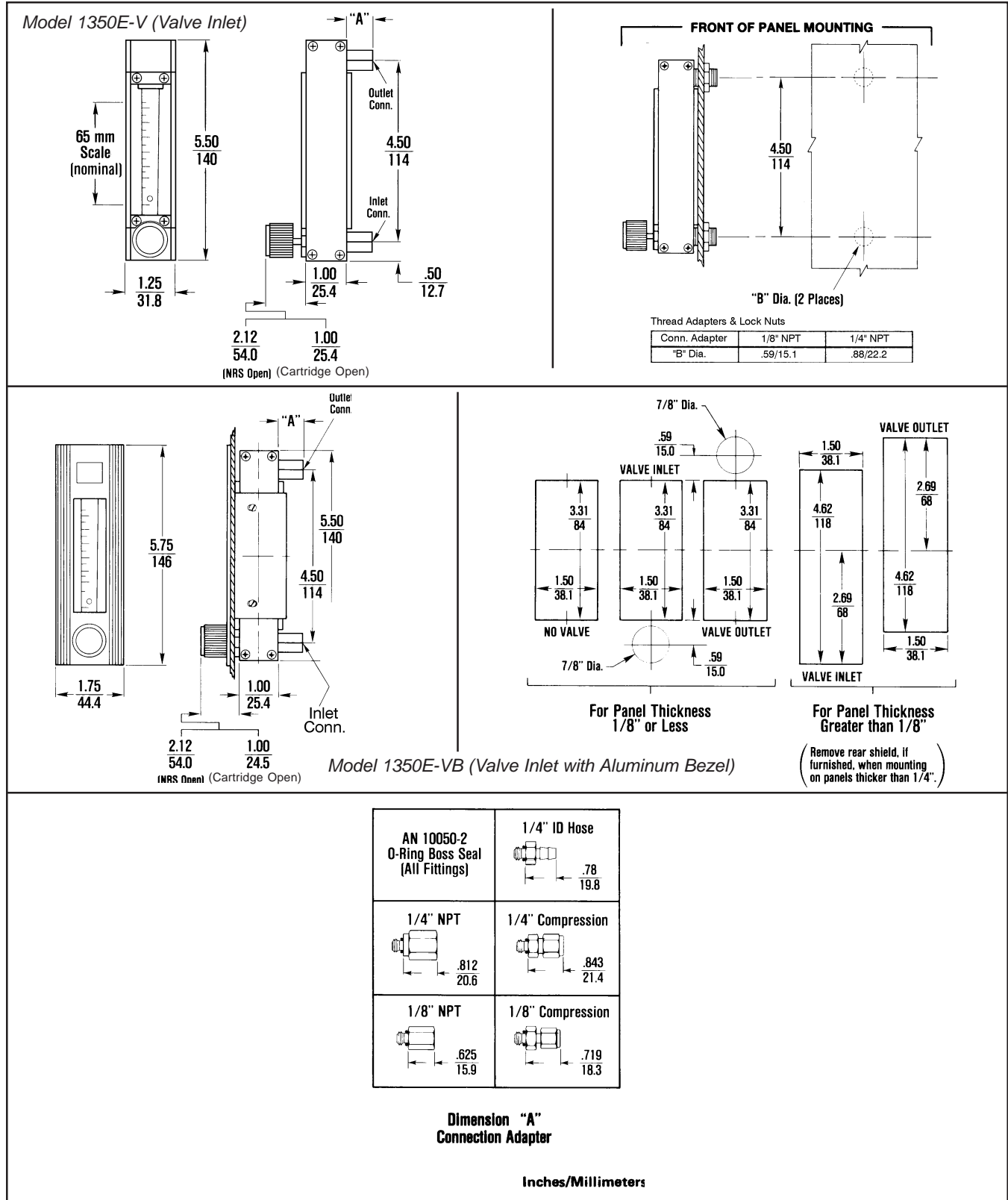

Figure 2-1 Typical Flowmeter Installation

It is recommended that a final leak test of the system plumbing and meter be performed before subjecting it to process fluid.
(See Section 4, Paragraph 4-2, e.)

Models 1350E and 1355E



2-4 Figure 2-2 Dimensions - Sho-Rate 1350E

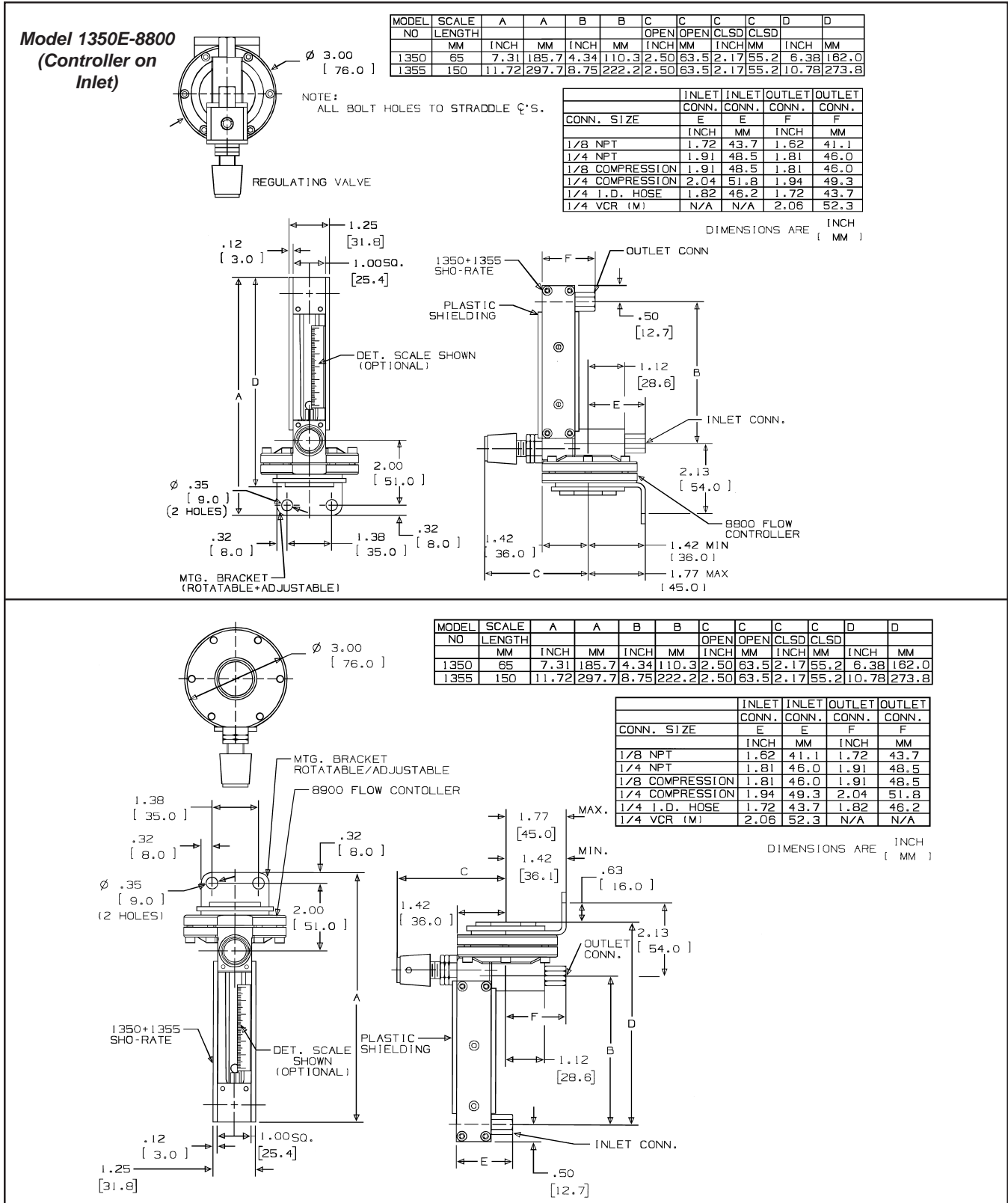
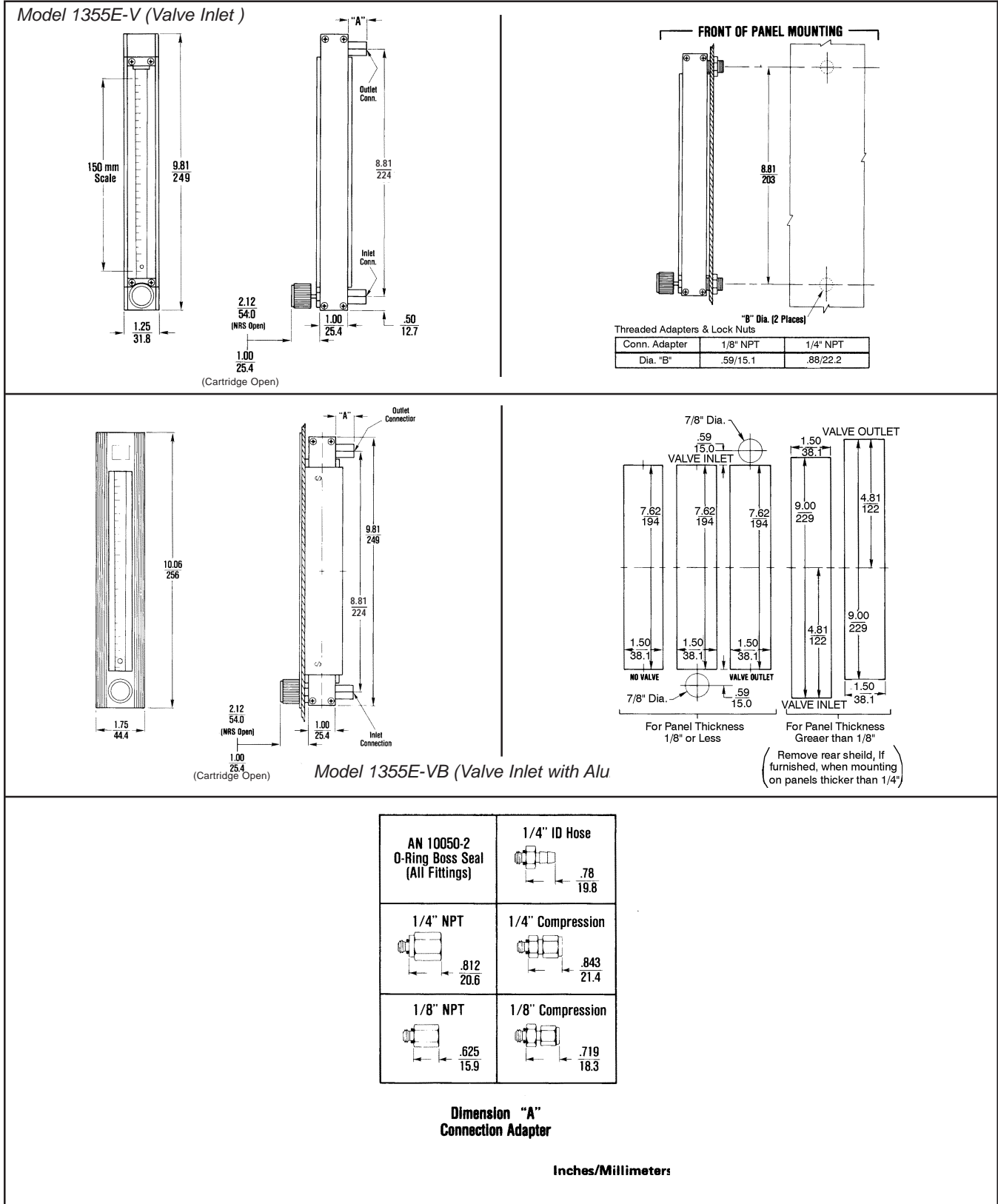

Figure 2-3 Dimensions - Sho-Rate 1350E & 1355E with Integral Flow Controller

Models 1350E and 1355E



2-6 Figure 2-4 Dimensions - Sho-Rate 1355E

3-1 Operation

After the flowmeter has been installed in the flow system, it is ready for operation. An optional built-in needle control valve may be provided to control the flow through the flowmeter. These control valves are designed for fine control. Excessive tightening may damage the valve seat and limit its effectiveness as a control valve. If tight shut-off is required, it is recommended that a separate shut-off valve should be installed in the line immediately before the flowmeter.

Flow indication is measured using the center of the spherical float as the reference point.

*THIS PAGE WAS
INTENTIONALLY
LEFT BLANK*

4-1 Disassembly and Cleaning

	! WARNING
METER/CONTROLLER SEAL COMPATIBILITY	
<p>Products in this manual may contain metal or elastomeric seals, gaskets, O-rings or valve seats. It is the "user's" responsibility to select materials that are compatible with their process and process conditions. Using materials that are not compatible with the process or process conditions could result in the Meter or Controller leaking process fluid outside the pressure boundary of the device, resulting in personnel injury or death.</p> <p>It is recommended that the user check the Meter or Controller on a regular schedule to ensure that it is leak free as both metal and elastomeric seals, gaskets, O-rings and valve seats may change with age, exposure to process fluid, temperature, and /or pressure.</p>	

It is recommended the user periodically inspect the tube and float, and clean if necessary. Dirt or foreign materials adhering to the tube and float may cause inaccuracy and sticking of the float. The metering tube (Borosilicate glass) and related parts may be cleaned with any solvent which does not attack glass.

*THIS PAGE WAS
INTENTIONALLY
LEFT BLANK*

5-1 General

When ordering parts please specify:
Brooks Serial Number
Model Number
Part Number
Description and Quantity
(Refer to Figure 5-1 and Table 5-1)

Models 1350E and 1355E

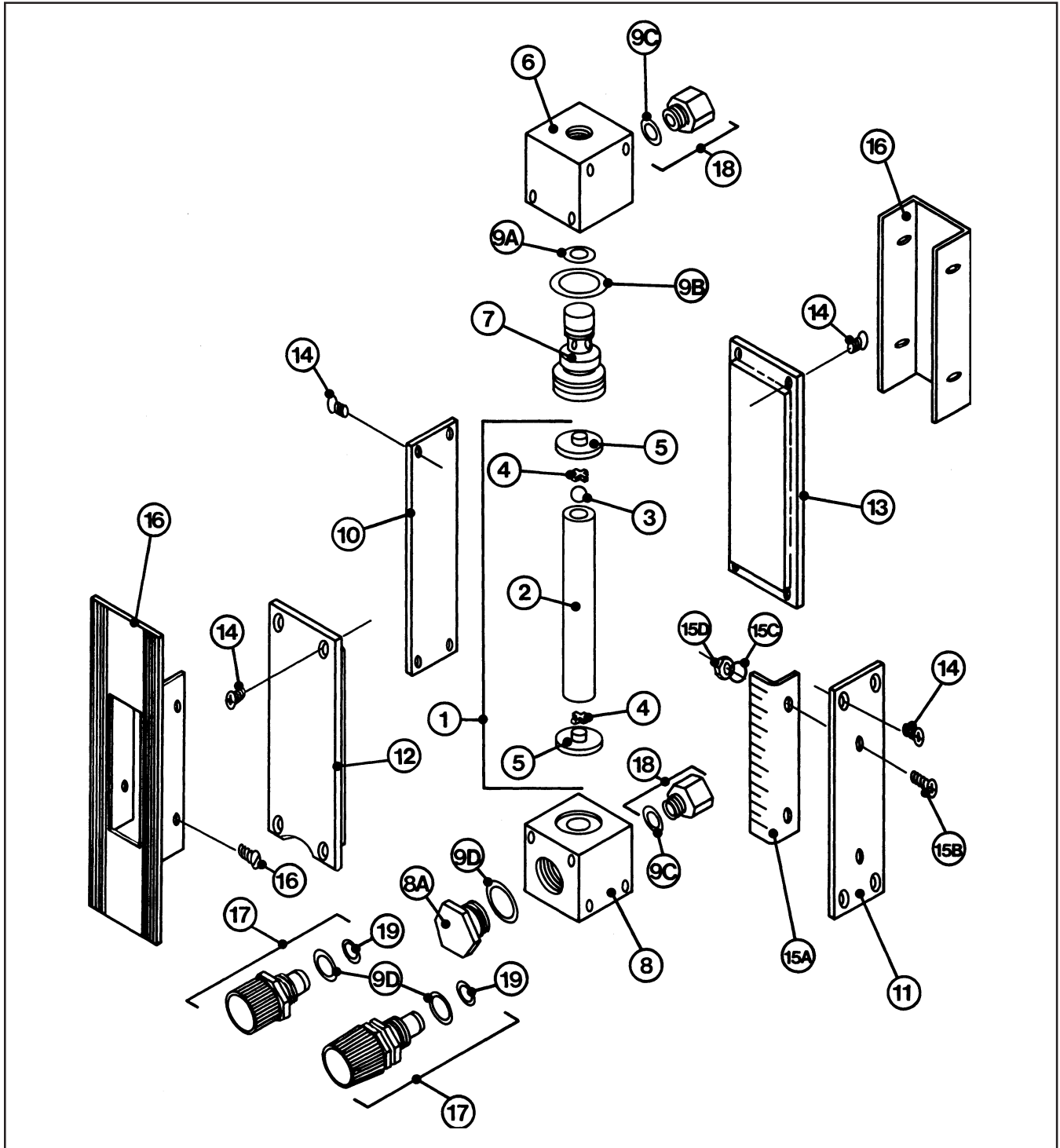

Figure 5-1 Parts Drawing Sho-Rate Models 1350E and 1355E

Table 5-1 Parts List - Sho-Rate Models 1350E and 1355E

Ref. No.	Qty.	Description
1*	1	Metering Tube Assembly
2	1	Glass Metering Tube
3	1	Ball Float (Size 1.5-1350 Only) Size 1 3/32" Glass Size 1 3/32" 316 SS Size 2 1/8" Glass Size 2 1/8" Sapphire Size 2 1/8" 316 SS Size 2 1/8" Carboloy Size 2 1/8" Tantalum Size 5 7/32" Glass Size 5 7/32" 316 SS Size 6 1/4" Glass Size 6 1/4" Sapphire Size 6 1/4" 316 SS Size 6 1/4" Carboloy Size 6 1/4" Tantalum
4	1	Inlet & Outlet Teflon Float Stops
5	1	Inlet/Outlet Tube Packing
6	1	Seal End Fitting (Outlet) Aluminum Brass 316 SS
7	1	Seal Spindle Aluminum Brass 316 SS
8	1	Valve End Fitting (Inlet) Aluminum Brass 316 SS
8A	1	Valve Plug Aluminum Brass 316 SS
9A*	1	Upper Seal Spindle O-ring Buna Viton Teflon
9B*	1	Lower Seal Spindle O-ring Buna Viton Teflon
9C	2	Adapter O-ring Buna Viton Teflon
9D*	1	Plug O-ring Buna Viton Teflon
10	1	Side Plate (STD) 1350 Aluminum STN. STL. 1355 Aluminum STN. STL.
11	1	Side Plate 1350 Standard Aluminum STN. STL. For Detached Scale Aluminum STN. STL.

*Recommended Spare Parts

Ref. No.	Qty.	Description
11	1	(Cont'd)1355 Standard Aluminum Stn. Stl. For Detached Scale Aluminum Stn. Stl.
12	1	Front Shield 1350 1355
13	1	Back Plate 1350 1355
14	16	Side Plate & Shield Screw
15A	1	Aluminum Det. D/R Scale
15B	2	Stn. Stl. Scale Screws
15C	2	Stn. Stl. Scale Washers
15D	2	Stn. Stl. Scale Nuts
16	1	Aluminum Bezel 1350 (No Valve) 1350 (With Valve) 1355 (No Valve) 1355 (With Valve)
17	1	Optional Valve Assembly Cartridge Valve Brass/Buna-N - Low Brass/Buna-N - Med Brass/Buna-N - Hi 316 S.S./Viton - Low 316 S.S./Viton - Med 316 S.S./Viton - Hi NRS Valve Brass/Buna-N - Size 1 Brass/Buna-N - Size 2 Brass/Buna-N - Size 3 Brass/Buna-N - Size 4 Brass/Buna-N - Size 5 Brass/Buna-N - Size 6 316 S.S./Viton - Size 1 316 S.S./Viton - Size 2 316 S.S./Viton - Size 3 316 S.S./Viton - Size 4 316 S.S./Viton - Size 5 316 S.S./Viton - Size 6
18	2	1/8" NPT Thd. Adapter w/Locknut Aluminum w/Buna Brass w/Buna 316 SS w/Viton 1/8" NPT Adapter Aluminum w/Buna Brass w/Buna 316 SS w/ Viton 1/4" NPT Adapter Aluminum w/Buna Brass w/Buna 316 SS w/Viton 1/8" Compression Adapter Brass w/Buna 316 SS w/Viton 1/4" Compression Adapter Brass w/Buna 316 SS w/Viton 1/4" I.D. Hose Adapter Aluminum w/Buna Brass w/Buna 316 SS w/Viton
19*	1	Orifice O-ring NRS Buna-N Viton Cartridge Valve Buna-N Viton

Models 1350E and 1355E

LIMITED WARRANTY

Seller warrants that the Goods manufactured by Seller will be free from defects in materials or workmanship under normal use and service and that the Software will execute the programming instructions provided by Seller until the expiration of the earlier of twelve (12) months from the date of initial installation or eighteen (18) months from the date of shipment by Seller. Products purchased by Seller from a third party for resale to Buyer ("Resale Products") shall carry only the warranty extended by the original manufacturer.

All replacements or repairs necessitated by inadequate preventive maintenance, or by normal wear and usage, or by fault of Buyer, or by unsuitable power sources or by attack or deterioration under unsuitable environmental conditions, or by abuse, accident, alteration, misuse, improper installation, modification, repair, storage or handling, or any other cause not the fault of Seller are not covered by this limited warranty, and shall be at Buyer's expense.

Goods repaired and parts replaced during the warranty period shall be in warranty for the remainder of the original warranty period or ninety (90) days, whichever is longer. This limited warranty is the only warranty made by Seller and can be amended only in a writing signed by an authorized representative of Seller.

BROOKS SERVICE AND SUPPORT

Brooks is committed to assuring all of our customers receive the ideal flow solution for their application, along with outstanding service and support to back it up. We operate first class repair facilities located around the world to provide rapid response and support. Each location utilizes primary standard calibration equipment to ensure accuracy and reliability for repairs and recalibration and is certified by our local Weights and Measures Authorities and traceable to the relevant International Standards.

Visit www.BrooksInstrument.com to locate the service location nearest to you.

START-UP SERVICE AND IN-SITU CALIBRATION

Brooks Instrument can provide start-up service prior to operation when required.

For some process applications, where ISO-9001 Quality Certification is important, it is mandatory to verify and/or (re)calibrate the products periodically. In many cases this service can be provided under in-situ conditions, and the results will be traceable to the relevant international quality standards.

CUSTOMER SEMINARS AND TRAINING

Brooks Instrument can provide customer seminars and dedicated training to engineers, end users and maintenance persons.

Please contact your nearest sales representative for more details.

HELP DESK

In case you need technical assistance:

- Americas ☎ 1 888 554 FLOW
- Europe ☎ +31 (0) 318 549 290
- Asia ☎ +81 (0) 3 5633 7100

Due to Brooks Instrument's commitment to continuous improvement of our products, all specifications are subject to change without notice.

TRADEMARKS

- Brooks Brooks Instrument, LLC
- Kalrez DuPont Performance Elastomer
- NRS Brooks Instrument, LLC
- Sho-Rate Brooks Instrument, LLC
- Teflon E.I. DuPont de Nemours & Co.
- Viton-A DuPont Performance Elastomer



Brooks Instrument
 407 West Vine Street
 P.O. Box 903
 Hatfield, PA 19440-0903 USA
 T (215) 362 3700
 F (215) 362 3745
 E-Mail BrooksAm@BrooksInstrument.com
www.BrooksInstrument.com

Brooks Instrument
 Neonstraat 3
 6718 WX Ede, Netherlands
 T +31 (0) 318 549 300
 F +31 (0) 318 549 309
 E-Mail BrooksEu@BrooksInstrument.com

Brooks Instrument
 1-4-4 Kitasuna Koto-Ku
 Tokyo, 136-0073 Japan
 T +81 (0) 3 5633 7100
 F +81 (0) 3 5633 7101
 E-Mail BrooksAs@BrooksInstrument.com

