

CIAAT CTC-940

user manual

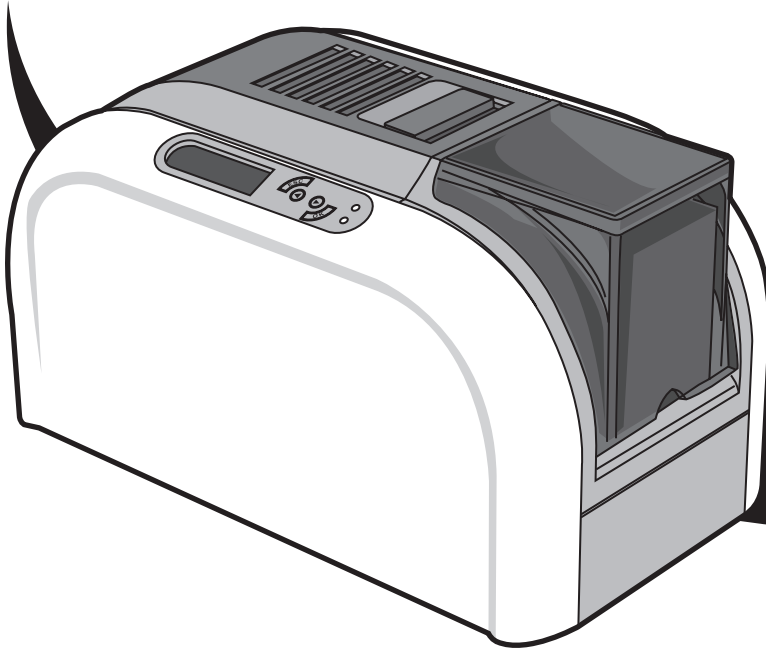

CONTENTS

PREFACE

Announcements	01
Chapter 1. Getting ready	03
1.1 Checking box contents	03
1.2 Appearance of the printer and key functions	04
1.3 Installation	06
1.3.1 Ribbon Installing	06
1.3.2 Printer Connecting (Power & USB)	07
1.3.3 Card Placing	08
Chapter 2. Start Printing	10
2.1 Printer driver installation	10
2.2 Print settings	11
Chapter 3. Printer maintenance	12
3.1 General warranty information notice announcement	12
3.2 Routine / Regular printer cleaning	13
3.2.1 Using cleaning card	14
3.2.2 Using dust arrester	15
3.2.3 Cleaning TPH (Thermal Print Head)	16
Chapter 4. Help diagnosis	17
4.1 Warnings / Error messages and diagnosis	17
4.1.1 LCM control panel	17
4.1.2 Control panel warning messages	18
4.2 Identify installed driver software version	19
4.3 Troubleshooting	20
4.3.1 Printing problems	20
4.3.2 Releasing from card jams	21
4.4 Technical support	22
Appendix A: Technical Specifications	23

Copyright

CIAAT CTC-940 Card Printer © 2011. All rights reserved.

Copyright notice

Users must comply with the copyright regulations applicable in their own country. This manual must not be reproduced, translated, photocopied, transmitted or any kind to be duplicated in whole or in part, for any reasons and by any electronic or mechanical means whatsoever without the express a written consent of the CIAAT Co.,Ltd.

All the information contained in this document is subject to changed without prior notice.

CIAAT Co.,Ltd. cannot be held liable for any errors that may be found in this manual, or for any loss or damage arising accidentally or as a result of dissemination or use of this manual.

Trademarks acknowledgement

CIAAT CTC-940 Card Printer is a trademark of CIAAT Co.,Ltd. product. All other trademarks belong to their respective holders.

Warranty

Refer to the warranty card supplied with your card printer package box for warranty terms, conditions and limitations.

Knowing your new printer

We thank you for choosing CIAAT CTC-940 card printer, the beginning of our long term successful association with you together. With CIAAT CTC-940 card printer, you will be able to enjoy easy operating, high quality plastic cards printing conveniently for personalized ID card, credit cards, membership cards and badges from various level of thickness and color style. Please ensure CIAAT CTC-940 card printer to use the original consumables from CIAAT Co.,Ltd. For more details, visit our website at www.ciaat.net .

Warranty Registration

Please do take time to register online at www.ciaat.net and you will be rewarded with a special offer after registration is completed.

Getting ready to start

The main purpose of this user guide is to guide you to set up your printer step by step. Please take time to read through this carefully and complete the installation before start operating. This will save you time during installation and use, help you to understand more about this printer and its features. Should you discover any errors in this guide, please do help us by emailing us at info@ciaat.net.

Assistant Icons

The following assistant icons will show up in this guide to indicate important information to be noticed.



Special warning notice



More in-depth information notice

Chapter 1. Getting ready

1.1 Checking box contents

CIAAT CTC-940 card printer is supplied with several accessories and please do take time to check it closely. The accessories contents list may vary depending from your region/location.



If any of below item is missing, please contact your nearest CIAAT customer support facility of your local CIAAT CTC-940 card printer distributor.

Accessories provide with your CIAAT CTC-940 card printer:

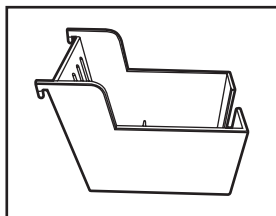

Card output hopper

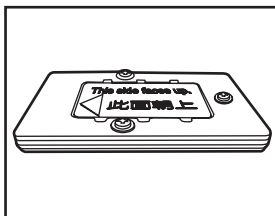

Weight module

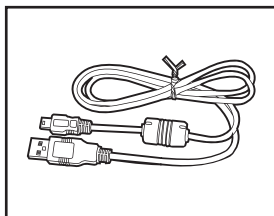

USB cable

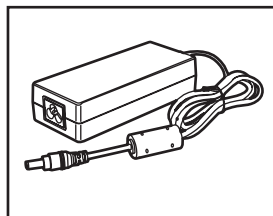

Power adaptor

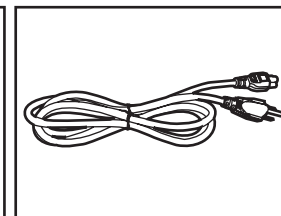

Power cord

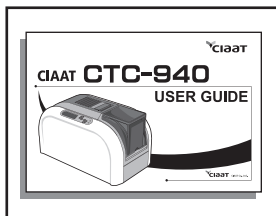

User guide

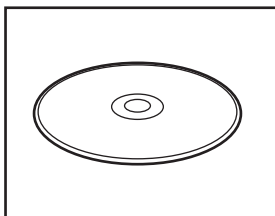

Master CD

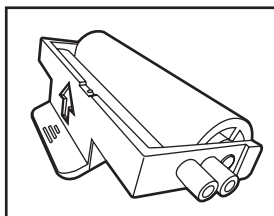

Dust arrester
with cleaning roller

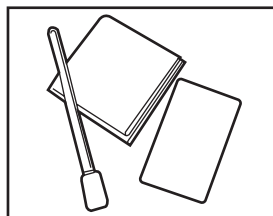

Cleaning kit

1.2 Appearance of the printer and key functions

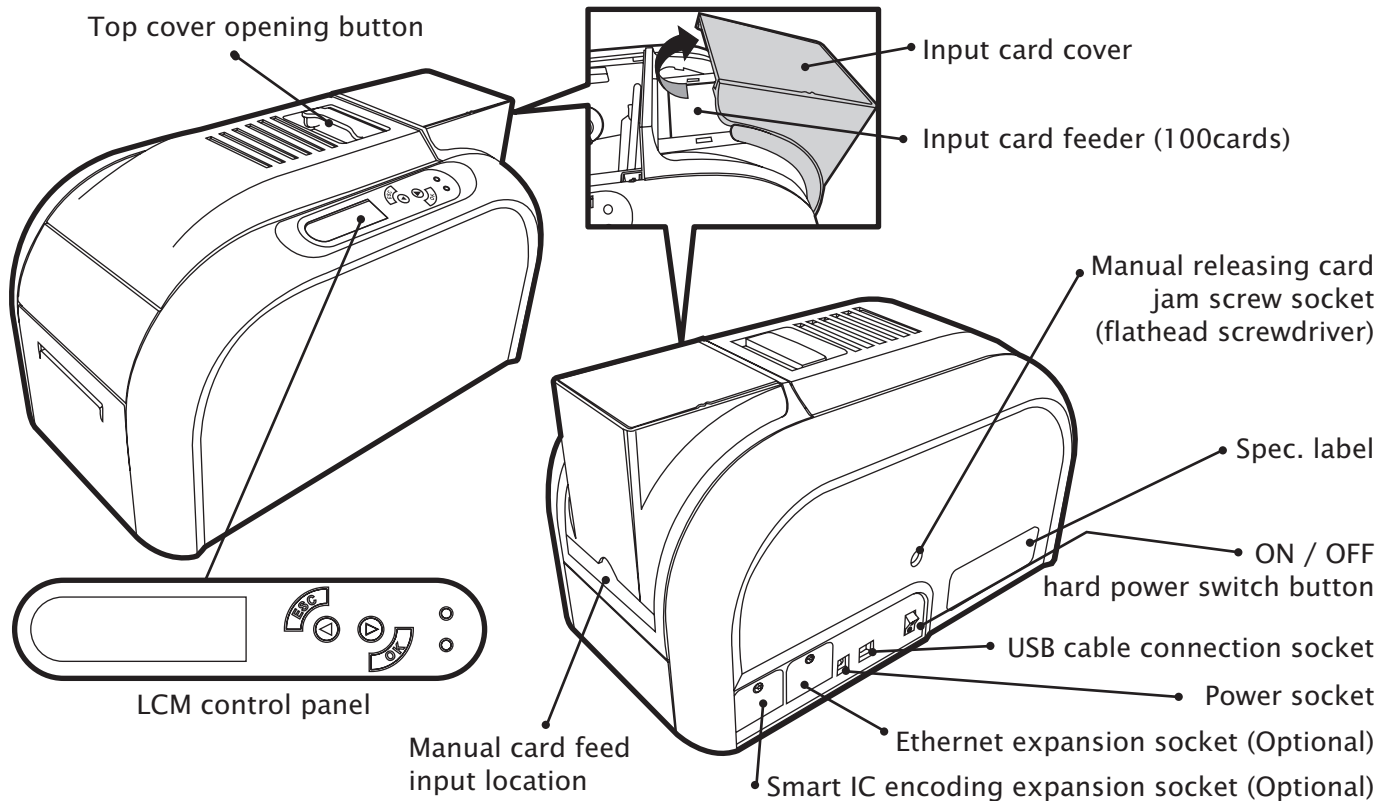

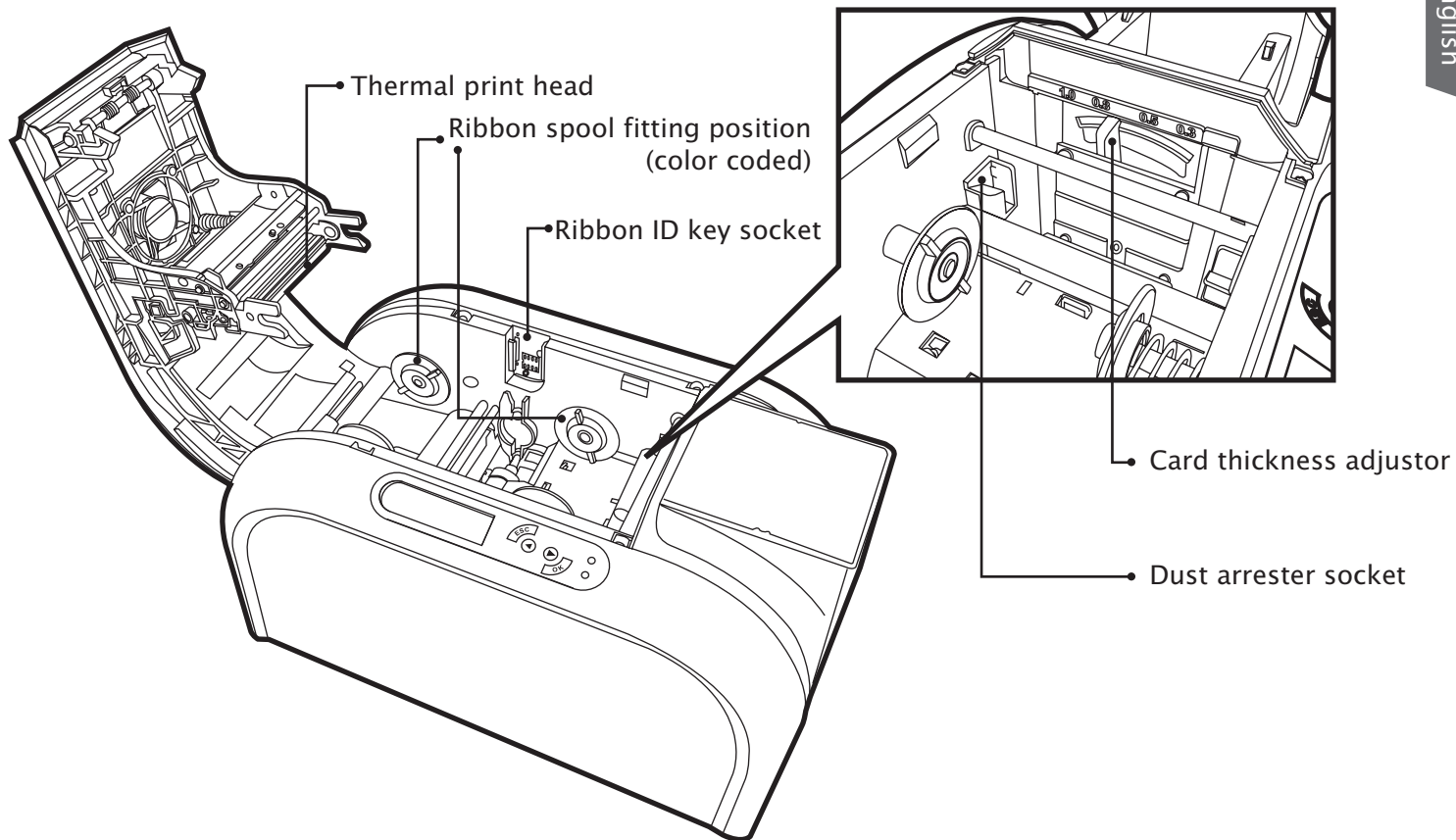

1.3 Installation

1.3.1 Ribbon Installing

Using the original CIAAT CTC-940 Card Printer Ribbon consumables will optimize your printer's performance and avoid causing damages to it. Use of non CIAAT original consumables will void the manufacturer's warranty policy for the printer.



To optimize printing quality, please engage in printer cleaning every time when the ribbon is changed.

- Open the top cover.
- Place the ribbon ID key into ID key socket.
- Insert the ribbon as shown.



Please ensure your ribbon format is corresponded to installed ribbon ID key's label.
Please make sure your ribbon film is facing top side during installation and also ensure the color of ribbon spool/core is matching to the ribbon adapter/holder.

- Close the top cover slowly and press until a click sound is heard.

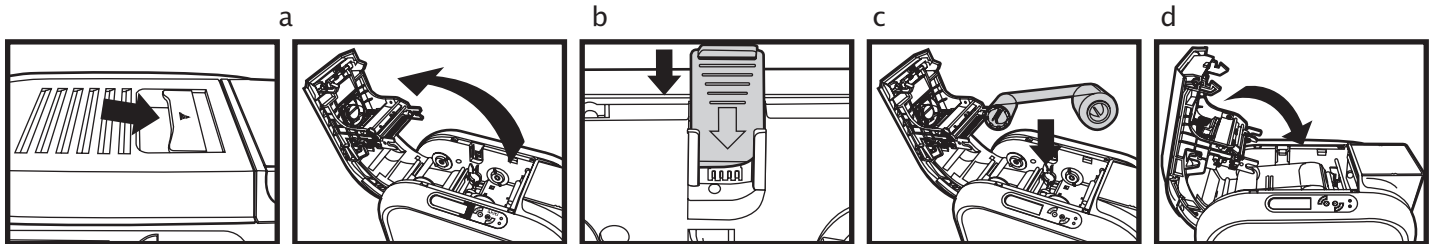

1.3.2 Printer Connecting (Power & USB)

Power

- Connect power cable to power adaptor, then plug the power connector to printer's power socket
- Plug the power plug to an earthed power socket



Please make sure the power plug is connected into a properly protected and earthed electrical source.

- Switch ON from the ON/OFF button to power up the printer, then the LCM control panel should light up and display "ready" message which indicates the printer is under working condition.



For your own safety, please make sure the power cable is always unplugged before attempting any service maintenance work.

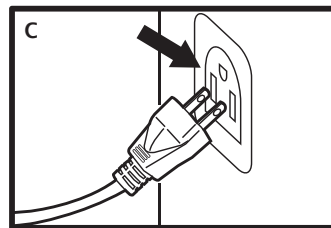
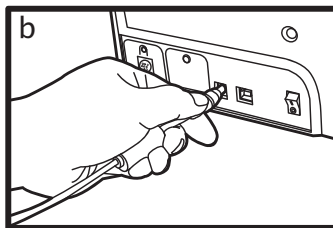
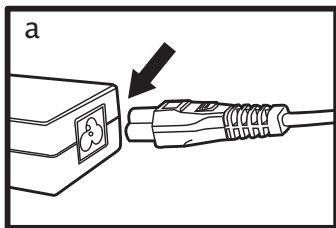

d



USB



Please make sure the print driver software is fully installed before connecting the USB cable to your printer device.

Refer to the print driver installation section of this user guide for more details, and follow the instruction carefully.

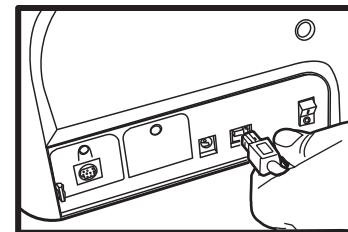

1.3.3 Card Placing

Loading (Automatic)



For optimum printing quality, please ensure all cards are CR-80 standard with ISO 7810 certified. Please do not touch the printable surface and not to use any dusty, damaged, folded or embossed cards in your printer.

- Open input card cover.
- Place the cards into input card feeder with positioned shown in the diagram.
- Close the input card feed cover.

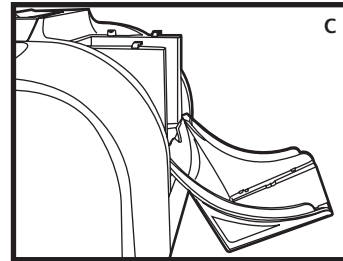
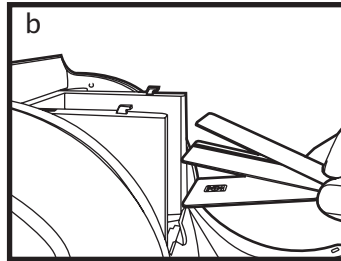
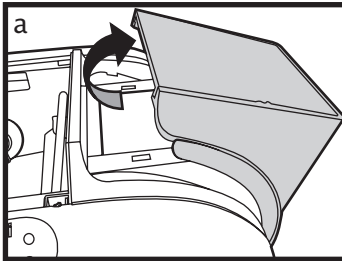

Card thickness adjustor



Loading (Manual queue jump)



This feature is designed when a single manually queue jump in printing or encoding job is required during fully loaded cards are positioned in input card feeder. Weight module is required for manual loading.

- Insert card manually with location and positioned shown in the diagram.
- Start printing or encoding command from PC.

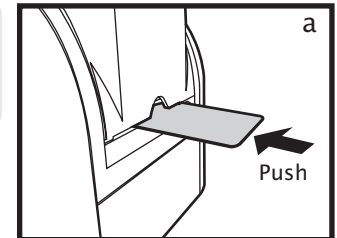

Collecting

When the printing and/or encoding cycle is completed, the printed and/or encoded card will be returned into output hopper which is designed with a capacity of 50 x 0.8mm cards.

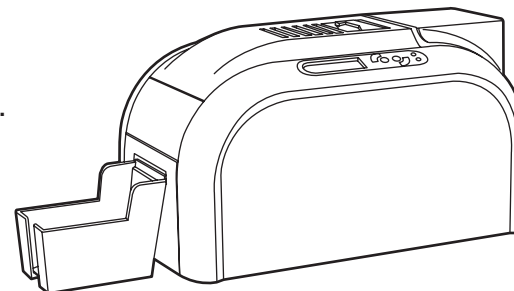

Adjusting

The printer has a manual adjustable card thickness mechanism which can be located inside the printer unit when the top cover is open. The thickness level accepts from 0.3mm to 1.0mm, and the factory setting is at 0.8mm.

Card thickness adjustor



- Open the top cover.
- Adjust the thickness level by moving the lever from left to right to the preferred thickness setting.
- Close the top cover.

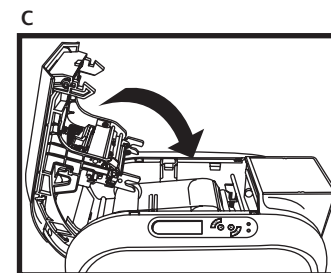
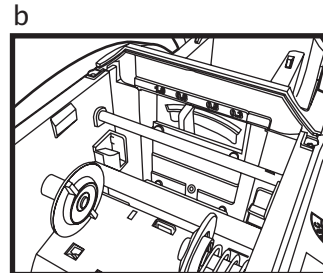
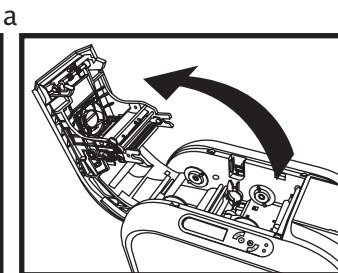
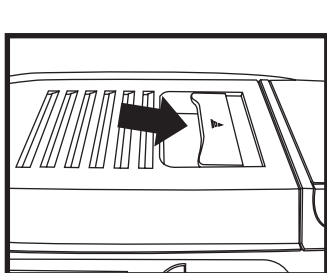

Chapter2. Start printing

2.1 Print driver installation



For your own safety, please make sure the power cable is always unplugged before attempting any service maintenance work.

This is an important step and requires special attention to configure the printer and driver correctly before start using it. Improper settings may result in substandard quality. It is essential to proceed installation process step by step, and changing any default settings only if when you are completely sure. We do offer an option to revert settings back to original factory settings at any time if any adjustment which you have made that does not correspond to the expected outcome results.

A CD is bundled with the printer which contains the printer driver for MS Windows-base PC.



If the CD guide is missing, please contact your nearest CIAAT customer support facility or your local CIAAT CTC-940 card printer distributor.

To begin install a print driver, please insert the CD into your computer and select the printer driver menu. A program will start and guide you through the entire configuration and settings process step by step.



Please refer to printer connecting section for USB connecting procedure in this user guide for more details.

Some version of Microsoft Windows may require the user to have administration rights to install the driver.

2.2 Print settings

Before start using your CIAAT card printer, it is very important to double check and/or change the default print driver settings. Those settings includes in the following list:

- ◆ Ribbon types
- ◆ Card types
- ◆ Card thickness
- ◆ Others



Please pay attention to the settings in printer driver and contact your local CIAAT distributor or dealer for any advice and assistance needed before attempting any changes.

Those settings of driver can be accessed from the following instructions:

- ◆ From the Start button (located bottom-left on the Windows task bar), select "Printers and Faxes"
- ◆ Select your CIAAT card printer and then follow by a click on right button of the mouse
- ◆ From the Printer menu, select "Printing Preference"
- ◆ A pop up configuration screen for CIAAT card printer appears
- ◆ The main menu tabs include Device Option, Printing Area, Color, Tools, Heating Energy, Magnetic Encoding, Import/Export & About

The most frequent use in print settings are Device Option, Color and Tools.

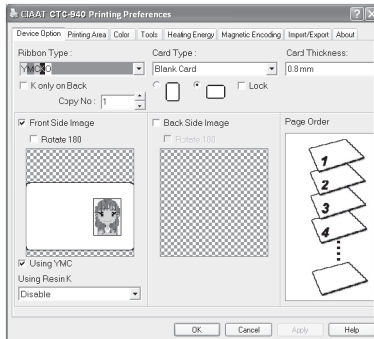

Device Option Tab

- Ribbon type
- Card type
- Card thickness
- Front & back image
- Page order
- Using Resin K

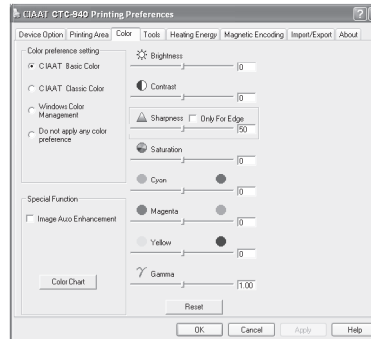

Color Tab

- Color preference setting
- Special function
- Color adjustment

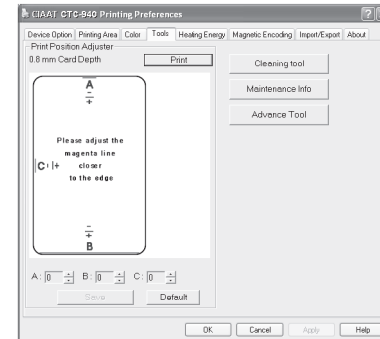

Tools Tab

- Printer position adjuster
- Cleaning tool option
- Maintenance info
- Advance option
- Heating energy option

Chapter3. Printer maintenance

3.1 General warranty information notice announcement

CIAAT CTC-940 card printer is professional designed to provide you a long term service duty with minimum regular maintenance required. Therefore please do comply with the instructions given in below to ensure your printer unit is covered by warranty condition.

*** IT'S IMPORTANT TO STAY COVERED BY YOUR WARRANTY!! ***



All the manufacturer's warranty conditions are subject to strict adherence to the regular routine servicing and maintenance instructions, and also printer cleaning cycles.



Any failure of the following required servicing and maintenance job duties mentioned in this chapter may void the print head warranty.

CIAAT CTC-940 card printer accepts no any other liability what so ever where it has been any single failure to perform required servicing and maintenance job duties on the printer. It is common to know that the print head is an extremely sensitive as well as a wearing and tearing component. Therefore the life expectancy is heavily depending on the presence of solids, dust or liquids in the environment, either on the print head or cards. Every operating user must take all necessary precautions to use clean cards in the printer unit. The frequency and quality of the servicing and maintenance job duties will not only extend the print head's life expectancy, but also maintain the output printed quality. It is very important to all users must comply with the servicing and maintenance instructions which described within this chapter.

Use of non CIAAT original consumables/ribbons may affect the quality and reliability of print job, low quality printed output and may also affect the printer's physical functions. The manufacturer's warranty does not cover any physical damages, quality problems and print head warranty by using non CIAAT original consumables/ribbons.

3.2 Routine / Regular printer cleaning



Proactive reminder of cleaning is given by the driver, and it is required to go with the instruction, or else the warranty on TPH may be invalid.

Item Description	Cleaning required after
Color / Mono Ribbon	400 cards
Magnetic Encoding	400 cards

3.2.1 Using cleaning card



Each pack/box of CIAAT CTC-940 original consumables should contain one single piece of cleaning card.

- a. Remove any remaining cards from input card feeder.
- b. Remove pilled protection film from the cleaning card and then place it in the feeder.
- c. Go to print settings in the driver, and access **Printing Preference**. Choose tab **Tools**, then apply **Cleaning Tool**.

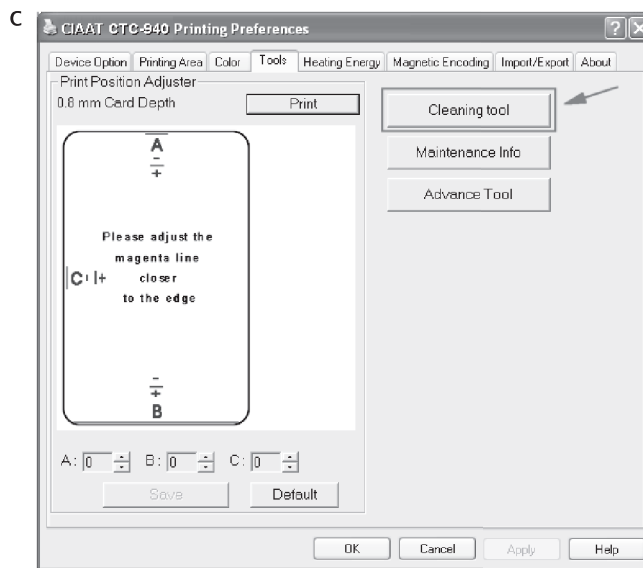
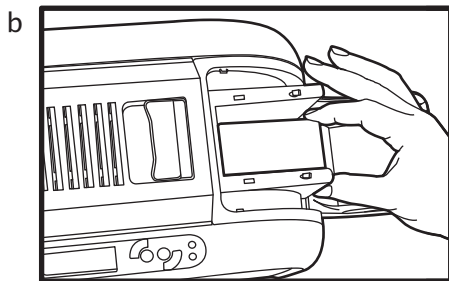
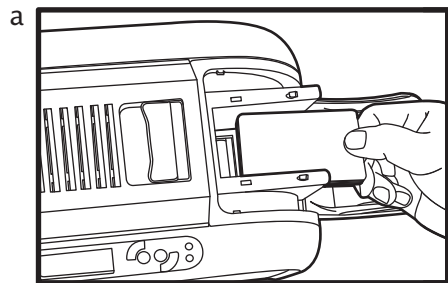

3.2.2 Using dust arrester

- i** Each pack/box of CIAAT CTC-940 original consumables should contain a set of dust arrester (with cleaning roller).

If first to use...

- Take the dust arrester with cleaning roller from the accessory box of printer carton.
- Remove adhesive film from the cleaning roller, and then put dust arrester into the printer.

If need to change cleaning roller of dust arrester...

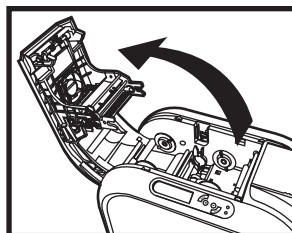

Open the cover gently

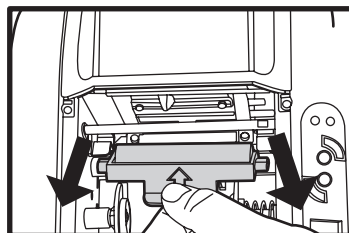

Take dust arrester from printer

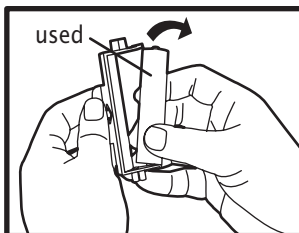

Remove the used cleaning roller

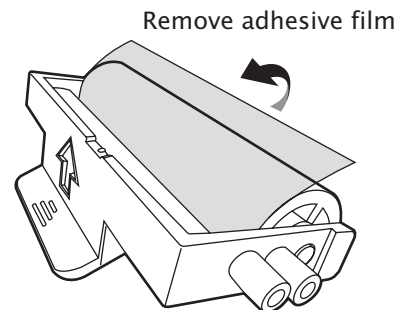

Remove adhesive film

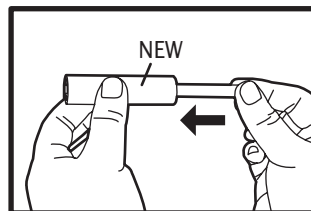

Put the metal shaft into the new cleaning roller

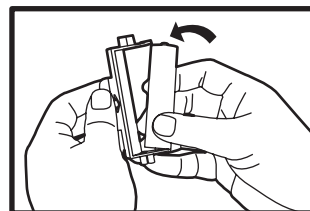

Assembly the roller and dust arrester

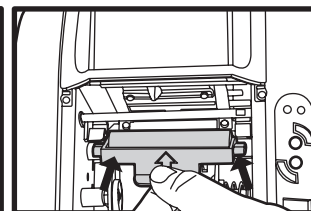

Place dust arrester back to the printer

3.2.3 Cleaning TPH (Thermal Print Head)



Please unplug the power cable from printer before start doing TPH cleaning process.
Try not to make any direct physical contact to TPH with any metal/sharp objects or your fingers.
The TPH and its components must be kept away from any discharge of static electricity.



In order to maintain original print out quality, it is highly recommended to perform this process every time when a ribbon is changed.

- Press the top opening button to open cover gently, and the TPH is attached to the ribbon door.
- Please use the sponge stick to clean the TPH.

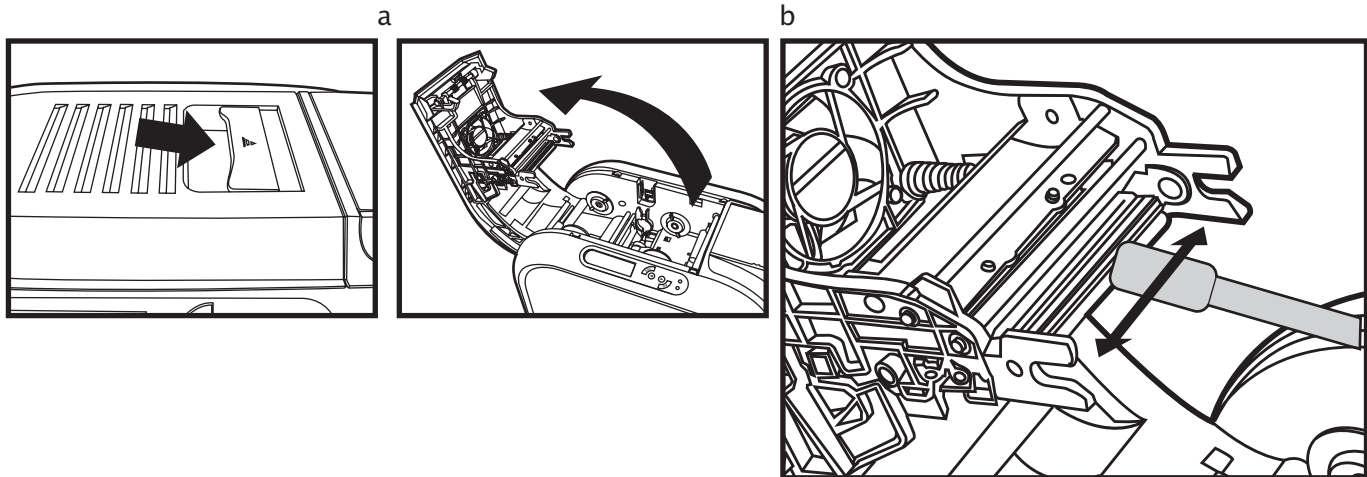

Chapter4. Help Diagnosis

4.1 Warnings / Error messages and diagnosis

CIAAT CTC-940 card printer is designed to get user involvement down to a minimum level. It is advised to gain some familiarity with basic warning messages knowledge during the operation.

4.1.1 LCM control panel

Basic descriptions

The printer is equipped with a LCD display with four buttons to give the access to printer menu and two LED lights to show conditional status. All printing status and warning/error messages will be displayed in this LCD screen.

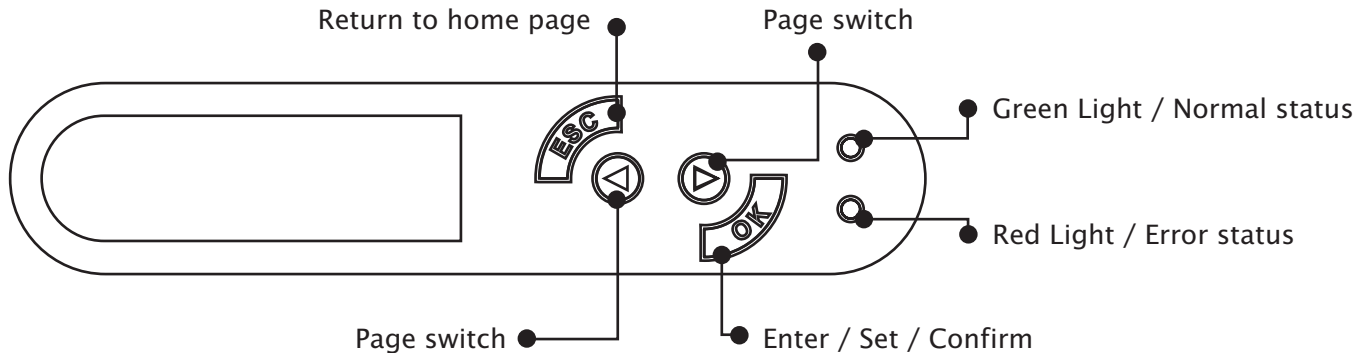

4.1.2 Control panel warning messages

PMessages Displayed	Description	Solutions
Cover Open	Top cover door is opened	Close the top cover door.
Flipper Cover Open	Flipper cover door is opened	Close the flipper cover door.
IC Chip Missing	Ribbon IC chip is not inserted	Install ribbon IC chip into printer's IC chip socket.
Ribbon Missing	Ribbon is not installed	Install ribbon with corresponded IC chip into printer.
Ribbon Mismatch	Installed ribbon does not match with ribbon IC chip ID	Check ribbon type and install the corresponded IC chip.
Ribbon Type Error	Unsupported ribbon type	Check ribbon's region code with matching printer's region code.
Ribbon Out	Failing to searching ribbon	Reinstall the ribbon again with correct installation procedure.
	End of ribbon usage	Reinstall a new ribbon with IC chip.
Print Fail	Fail to start printing process	Check the ribbon to see if it's snapped.
Card Out	Card runs out	Place more cards with card's weight module.
	Inconsistency between card thickness adjustor and card used	Get the setting of adjustor and card used consistent
	Adsorption force among cards	Move cards apart and then arrange them to input hopper for retry
Card Jam	Jammed during operation	Follow the LCM screen for releasing card jam instructions.
Card Mismatch	Different types of cards	Use CR-80 standard cards.
Cam Error	Internal mechanical cam platen error	Contact your local service center for professional advice.
Flipper Error	Flipper unable to perform its duty	Contact your local service center for professional advice.
Ribbon Error	Ribbon's IC chip error	Reinsert IC chip again or change a new IC chip if it's required.

4.2 Identify installed driver software version

You can easily identify your driver version by accessing from your printer properties menu. It is essential to keep your printer driver to be the latest version which always published from official CIAAT web site.

Checking your driver version can be accessed from the following instructions:

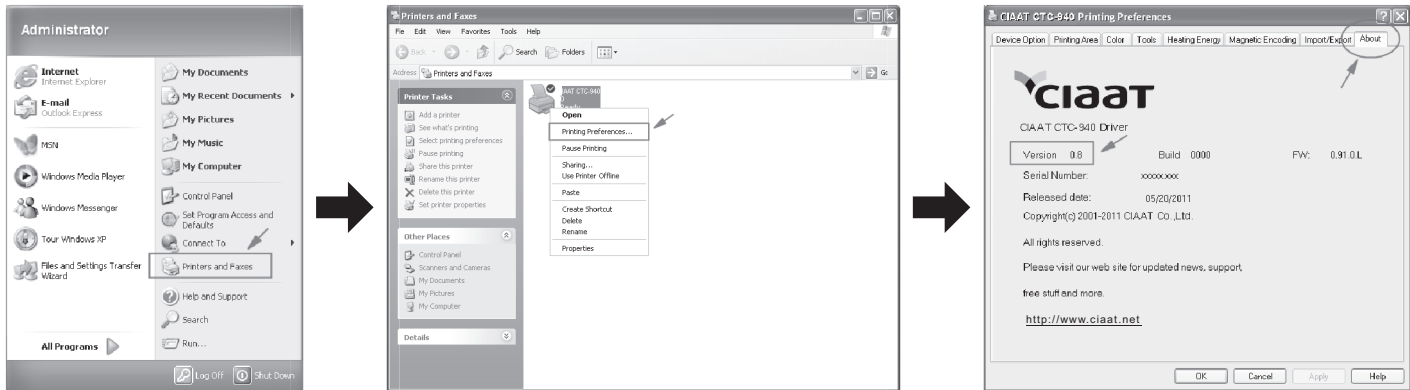

4.3 Troubleshooting

4.3.1 Printing problems

Nothing in action	<ul style="list-style-type: none"> ◆ Check the printer driver to see if it is truly, well installed. ◆ Check the printer power supply and USB cable ◆ Check the ribbon and card ◆ Print a demo chart
Printed a blank card	<ul style="list-style-type: none"> ◆ Check the ribbon ◆ Check value A setting of “Printing Area” in the driver. To define value A as default to retry. ◆ Check the card to see if it carter to CR-80 specification
Partial or incorrect printing	<ul style="list-style-type: none"> ◆ Check the printer settings ◆ Check the interface cable and ribbon ◆ Make sue the printer’s cleaning roller is clean ◆ Check the printing card is clean ◆ Check the print head
Printed some small blemishes	<ul style="list-style-type: none"> ◆ The card surface may be dirty or work on cleaning via dust arrester ◆ Print head clogged ◆ Check the roller of dust arrester to see if there’s need to change a new one
Printed horizontal white lines	<ul style="list-style-type: none"> ◆ Check the ribbon is fitted correctly ◆ Check the print head is dirty or damaged
Printed vertical white lines	<ul style="list-style-type: none"> ◆ TPH may be impaired. Contact the distributor or dealer nearest to you for help.
Printed blurred images	<ul style="list-style-type: none"> ◆ Check the ribbon to see if is fitted correctly ◆ Check the print head to see if there’s need to do the cleaning ◆ Check the cleaning roller of dust arrester to see if there’s need to change a new one. Check the card is compatible or not

4.3.2 Releasing from card jams

Please remove the jammed card by the following instruction displayed on LCM control panel of the printer before continuing the printing job.

- ◆ Open the printer cover door
- ◆ Remove the ribbon
- ◆ Follow the instruction on the LCM control panel with three options: Auto removal, Semi-auto removal and Manual removal



During semi-auto removal and manual removal process, please do not put your hands into the card printer.

You can also perform the following steps to prevent card jams:

- ◆ Check the card thickness settings is correctly adjusted from the printer driver option and thickness gauge
- ◆ Check the card thickness is fitted under specified specification in this manual
- ◆ Check the cards are flat in horizontal position
- ◆ Check the cards are not stuck together, and shuffle cards is required before loading

Illustration for manual removal card jams:

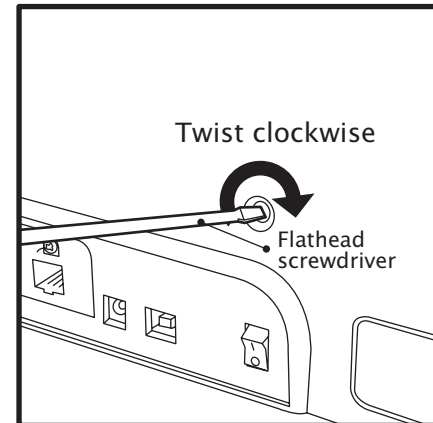

4.4 Technical support

If you have come across any difficulties in configuring and/or operating your CIAAT card printer, please read this manual carefully.

If you are unable to manage solving your problems, you can obtain further information or help from your local authorized distributor or reseller.

For any unresolved technical problems, if you don't know your local distributor or reseller. You can visit our website www.ciaat.net for contacting information and send us your questions.

We will be more than happy to assist you at anytime. It is important for you to provide those following information at anytime during your contact for servicing help:

- ◆ Your printer model and serial number
- ◆ The configuration and operating system which you are using
- ◆ A detail descriptions of the incidents/problems which has occurred
- ◆ A detail descriptions of the steps which you have already taken to solve the incidents/problems

If you need any additional information or technical help, you can obtain those information from our website www.ciaat.net which offers you the ability to download the latest printer driver, firmware, user manual, and FAQ (Frequent Ask Questions) to maintaining your CIAAT card printer.

Appendix A: Technical Specifications

CIAAT CTC-940 Card Printer	
General Technical Features	<ul style="list-style-type: none"> ◆ Color printing module ◆ 300dpi print head ◆ USB connection ◆ Ethernet TCP/IP connection as an optional module (Availability to be updated) ◆ 32MB RAM / 1MB Flash ◆ 50 cards output hopper (0.8mm/30mil) ◆ 4 buttons and 2 LED control panel
Printing Modes	<ul style="list-style-type: none"> ◆ Color sublimation and monochrome thermal transfer ◆ CIAAT color technology enhanced ◆ Edge to edge printing ◆ A.I smart ribbon saving for monochrome printing
Performance (various from card design & settings)	<ul style="list-style-type: none"> ◆ Color: 1 side (YMCKO) = around 20 sec (under lab testing environment) ◆ Monochrome: 1 side = 5 sec
System Request	<ul style="list-style-type: none"> ◆ IBM-PC or compatible, Windows 2000/XP/Vista, Pentium R class 133MHz above ◆ Computer with 128MB RAM or higher, 100MB free hard disk space or higher
Supported Platforms	<ul style="list-style-type: none"> ◆ Windows 2000/XP/Vista/Windows 7 (32 & 64 bits)
Add/Supplied Software	<ul style="list-style-type: none"> ◆ Ciaat CTC-940 CS

Ribbon Types	<ul style="list-style-type: none"> ◆ YMCKO (200/400 prints) ◆ 1/2 YMCKO(280/560 prints) ◆ 1/3 YMCKO(330/660 prints) ◆ KO(500/1000 prints) ◆ K (2000 prints)
Options (Easy Add Modules)	<ul style="list-style-type: none"> ◆ 400 cards high capacity input hopper ◆ Flipper module ◆ Magnetic encoding module (ISO 7811 HiCo/LoCo or JIS2 magnetic strip encoder) ◆ Smart IC encoding module (ISO 7816-2 / PC/SC, EMV 2000-1) ◆ Contactless/RFID encoding module (ISO 14443A, B, ISO 15693, Mifare, DesFire, HID iCLASS) ◆ Ethernet connection module
General Information	<ul style="list-style-type: none"> ◆ Card types: PVC card ◆ Card format: ISO CR-80 / ISO 7810 (53.98mm x 85.60mm) ◆ Card thickness: From 0.3mm(10mil) to 1mm (40mil) – Dual side printing: From 0.5mm (20mil) ◆ Input card feeder capacity: 100 cards (0.8mm/30mil) ◆ Output hopper capacity: 50 cards (0.8mm/30mil) ◆ Printer dimensions: 197.8mm (W) x 354mm (L) x 204mm (H) ◆ Weight: 4.9kg ◆ Connections: USB port, Ethernet TCP/IP port as an option (Ethernet 10/100 Mbps) ◆ Power supply: AC input: 100~240V~2.5A, 50~60Hz / DC output: 24V = 4.16A ◆ Operating environment: +15°C to +32°C / 20% to 85% RH (without condensation) ◆ Storage environment: -20°C to +60°C / 20% to 90%RH (without condensation) ◆ Operating ventilation: open cooled air area



▲ © 2011 CIAAT Co., Ltd. All Rights Reserved.

▲ Specifications are subject to change without notice.