

# User Manual

## LED Disco Panel



Please read over this manual before using

## 【Before Installatio  】

### Guide

In order to optimize the performance of this product, please read the following details to be familiar with the basic product operation instruction, security matters, way of use And maintain. Please keep this manual for future reference.

### Product withdrawal

Thank you for purchasing the LED DISCO PANEL, every tiles of floor have passed the strict factory test, please feel free to use it. After receiving the goods, please firstly inspect them then to sign in. If the cartons have damaged, check carefully the internal lamps and the parts are intact; If not, please contact with the manufacturer or your dealer to get further instructions, please do not directly reject the goods.

### Brief Introduction

LED DISCO PANEL is a type of smart lamp which have the Auto and Sound-Active mode, and also can be controlled by DMX.

### Warning



Please do not try to maintain and repair the lamps by yourselves, there is no parts to be repaired or replaced inside the lamp, or we will not offer the warranty service. If there is damage happens in using process, please contact with the manufacturer or your dealer at the first time, or do the maintenance and replacement under the guidance of professional

### Carton



Packing Carton can be recyclable.

# LED Disco Panel

## 【Description】

### Features

Various color mixing and effect optional

Various color strobe

Electronic dimming: 0-100%

Sound-Active inside

DMX-512/Computer Control

Master-Slave

Digital operation menu and function button

Power off Memory

### Electronic Specification

Input Voltage: 90~250V

Lamp Source: 1 w high brightness led lamps inside.

Each panel with 36pcs led lamps (R:12 G:12 B:12)

Each tile with 4 modules (modules are interchangeable), Each module are comprised by 9 led lamps.

Power Supply : High quality power switch which are flexible between 110 V and 220 V. A good quality power is essential to extend the lifetime of a lamp.

Lifetime: ≥50000 hours (in normal operating condition)

Working Environment: -10°C~+40°C

Cooling Way: Convection cooling with no fans

Protection Rate: IP65, dustproof and shock resistance (Which can be used indoor or outdoor)

Physical Specifications (Photo below is the measurement)

Material: ABS base and cover, base can bear 100 kg with no shape change and no cover bear

Panel Size: 500x500x138mm

Net Weight: 2.8KG

Packing Size: 560x560x175mm (1 pcs/Carton)    xxmm (4 pcs/Carton)

Packing Weight : 3.7KG (1 pcs/Carton)    16.7KG (4 pcs/Carton)

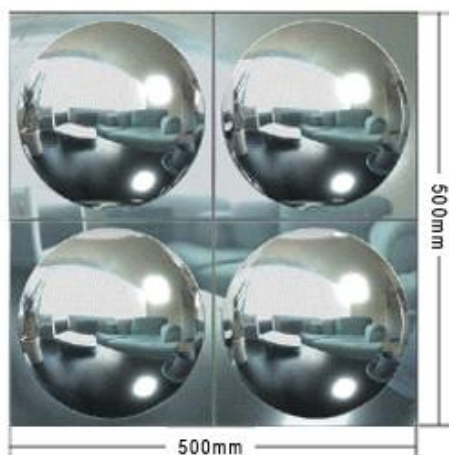

# LED Disco Panel

## Operating Instructions

Sound Active Mode: different effects changed with the sound

Auto Mode : Can change different color automatically and operate the built-in program

Master-Slave Mode: The product shall be run in slave mode. After all the lamp signal cable and power cord are connected normally, select any one of lamp and set the control board to be Auto mode as the host. Others are set in the address code d.001 as a slave, all the product will be synchronized with the host.

DMX Control Mode: Controlled and edit by international agreement DMX-512

Light will go to Auto mode by setting control board when not have DMX controller connected. The effect same change with the first light while many lights connected.

Connect the lights and connect the DMX controller, later go the LED DISCO PANEL channels chart.

Note: Lights are operated by computer if connected with computer software.

## Control Board

Control Board	
Button	Function
<MENU>	Select or exit the current menu
<UP>	Add Value
<DOWN>	Reduce Value
<ENTER>	Confirm Select

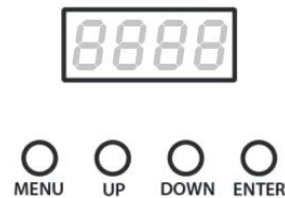

menu display and function Settings			
NO.	Menu	Function	remark
1	A001	console mode or slave mode	
2	G-1-	sound mode	
	G-2-	AUTO effect 1	
	G-3-	AUTO effect 2	
	G-4-	AUTO effect 3	
	G-5-	AUTO effect 4	
	G-6-	AUTO effect 5	
	G-7-	AUTO effect 6	
	G-8-	AUTO effect 7	
3	G-9-	lighting-off	
	r000	Manual dimming	press ENTER to choose color
	G000		
b000			
4	FADE	effect of pulse variable	
5	SMTH	gradient effect	
6	STRO	Random strobe	

If you want to keep the origin mode after power off include all mode above, Please press "ENTER" to confirm after operation.

# LED Disco Panel

## DMX Mode

Users can create your own needs program by DMX console.

International standard DMX-512 signal control to achieve a variety of effects

Detail channel functions please refer to the following <channels of LED DISCO PANEL >

Use Manual: connect the DMX console with the lights by XLR plug and set the DMX address

## Pixels Distinguish Figure

CH 1	54-63	AUTO effect 4	auto mode
	64-79	AUTO effect 5	
	80-95	AUTO effect 6	
	96-111	AUTO effect 7	
	112-127	AUTO effect 8	
	128-143	AUTO effect 9	
	144-159	AUTO effect 10	
	160-175	AUTO effect 11	
	176-224	AUTO effect 12	
	225-245	sound control effect	sound mode
245-255	CH4-CH7 dimmer		
CH 2	0-127	auto speed from fast to slow , effect with positive sequence	valid in auto mode
	128-255	auto speed from slow to fast , effect with reverse sequence	
CH 3	0	strobe off	valid in auto mode
	1-127	strobe effect 1 speed , from fast to slow	
	128-254	strobe effect 2 speed , from slow to fast	
	255	strobe off	
CH 4	0-255	dimmer	valid in dimmer mode
CH 5	0-255	1 st pixels light , red , brightness adjusted , brighter as value bigger	set up overall R
CH 6	0-255	1 st pixels light , green , brightness adjusted , brighter as value bigger	set up overall G
CH 7	0-255	1 st pixels light , blue , brightness adjusted , brighter as value bigger	set up overall B
CH 8	0-255	2 st pixels light , red , brightness adjusted , brighter as value bigger	
CH 9	0-255	2 st pixels light , green , brightness adjusted , brighter as value bigger	
CH 10	0-255	2 st pixels light , blue , brightness adjusted , brighter as value bigger	
CH 11	0-255	3 st pixels light , red , brightness adjusted , brighter as value bigger	
CH 12	0-255	3 st pixels light , green , brightness adjusted , brighter as value bigger	
CH 13	0-255	3 st pixels light , blue , brightness adjusted , brighter as value bigger	
CH 14	0-255	4 st pixels light , red , brightness adjusted , brighter as value bigger	
CH 15	0-255	4 st pixels light , green , brightness adjusted , brighter as value bigger	
CH 16	0-255	4 st pixels light , blue , brightness adjusted , brighter as value bigger	
CH 17	0-255	White1	
CH 18	0-255	White2	
CH 19	0-255	White3	
CH 20	0-255	White4	

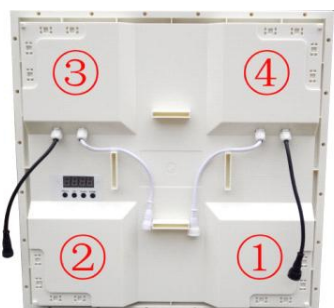

# LED Disco Panel

## 【Installation and Settings】

### Safety Precautions

- Do not spill water or other liquids into the product;
  - Ensure that your local power outlet match with the product voltage;
  - If the power cord is frayed or damaged, do not attempt to operate the product, and do not attempt to re-moved or broken wire GND which can reduce internal short circuit caused by electric shock and fire hazard;
  - Disconnect the main power supply before any type of connection;
  - Any case are not allowed to disassemble the cover, no parts you can repair or replace inside the lamp;
  - Do not operate the product when the cover is removed;
  - Failure, do not force to run the product;
  - Disconnect the main power supply when not in use for a long time;
  - The path of the power lines should be properly arranged, so that the line will not be walked on or pinched.
- Pay special attention to this point while pulled off the line from the device;
- Clean up the product for detail information see “cleaning”;
  - Equipment should position away from heat sources such as radiators, stoves or other appliances (including amplifiers) which can produce heat;
- The following occurs in need of repair:
- A. The power cord or the power supply has been injury
  - B. Products falling from height, or product internal splashed into water or other liquid
  - C. Product get wet by rainstorm or water
  - D. Product can not operate normally or when significant changes occur in the performance;

### Installation

#### ① The connectit o of th signal cable and powe cables between panels

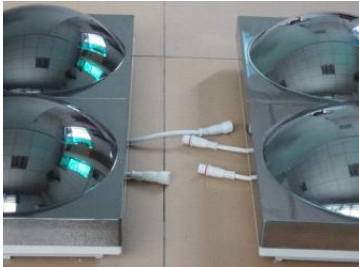

The female of one panel should be close to the male of another panel.



Connect the 3 cores female with the 3 cores male. Connect the 2 cores female with the 2 cores male. And screw up them in the clockwise direction



Adjust the cables position to let them hide in the grooves of the panels. Then put the panels to gether.

Please lock the nearby panels by our cross fixtures.

Note:500mm from central between two plates as picture shown

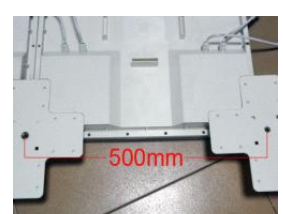

## LED Disco Panel

- 2 The first or last panel are connected with the controller

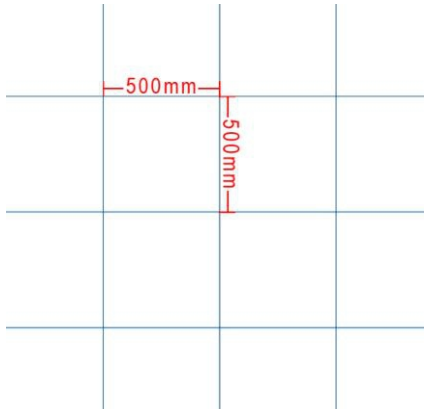

### How to fix the panel on the wall

- 1 Drawing on the wall with 50\*50cm size as photo show;



- 2 Fix the screw we equip for you on the cross place as photo show:

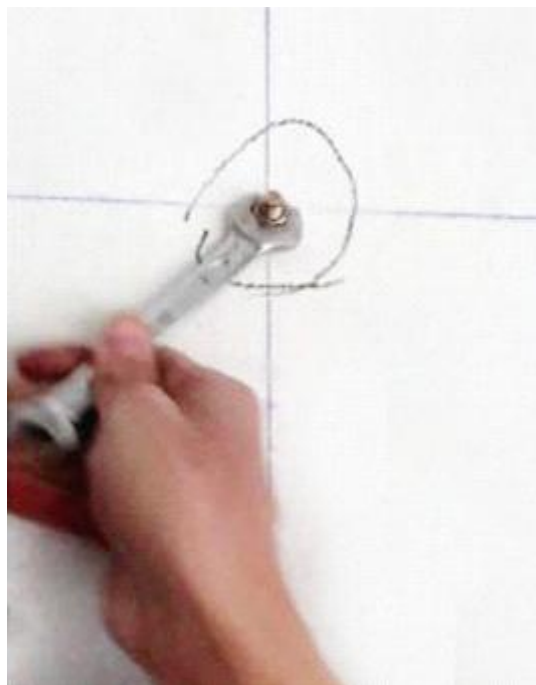

## LED DiscoPanel

- 3 Fix the cross fixture of led bubble panel on the wall by screw:



- 4 Push the bubble panel on the cross fixture directly and finalize the installation.



To easy punch and fixed, please use flameproof board or PC board as a fixed plate if possible.



## Trouble Shooting

Listed below are some common problems solutions:

### 1.Product can not receive DMX signal

Check the DMX signal cable is properly connected, besides check all the wiring is connected to the correct connector, especially the input and output connection

### 2.Product can not receive sound

Quiet or sharp sound will not activate the product, change another panel if the problem persists, please contact your dealer to serve you when it still useless.

### Regular Cleaning

Keep this product around no other heat-generating items, some dust adhesion will be in after using for some time, timely clean-up is very important;

Cleaning should be extra carefully when you clean the product and should avoid liquid spilled into the inside of the product;

Using water or a mild soap and a soft cloth to wipe the exterior of the product (avoid using strong base, concentrated alcohol or organic solvents);

The frequency of cleaning for the product depends on the influence of the environment (such as smoke, fog residue, dust, dew, etc.)

Note: Data are subject to change without notice. If you are interested in this product, please check with your dealer or our requests for updated information or video.