

Compact performance



FESTO

Electronics manual

CP modules

Input module
type

CP-E16...-M...-...

Input module
type

CP-E16-KL-IP20-Z

Output module
type

CP-A08...-M12-...

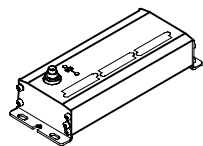
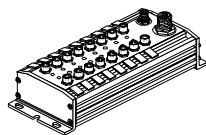

Manual

165 225

en 0802e

[730 690]

Contents and general instructions

Original de

Edition en 0802e

Designation P.BE-CPEA-EN

Order-no. 165 225

© (Festo AG & Co. KG, D-73726 Esslingen, Federal Republic of Germany, 2008)

Internet: <http://www.festo.com>

E-Mail: service_international@festo.com

The copying, distribution and utilization of this document as well as the communication of its contents to others without expressed authorization is prohibited. Offenders will be held liable for the payment of damages. All rights reserved, in particular the right to carry out patent, utility model or ornamental design registration.

Contents

Designated use	V
Target group	VI
Service	VI
Important user instructions	VII
Notes on the use of this manual	IX
1. Input modules type CP-E16...-M...-...	1-1
1.1 Function of input modules type CP-E16...-M...-...	1-3
1.1.1 Display and connecting elements	1-4
1.2 Fitting	1-6
1.3 Installation	1-10
1.3.1 Determining PNP or NPN operation (only with type CP-E16-M8-Z)	1-11
1.3.2 Connecting the separate power supply for the sensors (only with type CP-E16-M8-Z)	1-12
1.3.3 Connecting the sensors	1-15
1.3.4 Connecting the input module	1-26
1.4 Instructions on commissioning	1-28
1.5 Technical specifications	1-33
2. Input module type CP-E16-KL-IP20-Z	2-1
2.1 Method of operation of input module CP-E16-KL-IP20-Z	2-3
2.1.1 Display and connecting elements	2-4
2.2 Fitting	2-5
2.3 Installation	2-8
2.3.1 Determining PNP or NPN operation	2-9
2.3.2 Connecting the separate power supply for the sensors	2-10
2.3.3 Connecting the sensors	2-13
2.3.4 Pin assignment (PNP and NPN inputs)	2-16
2.3.5 Circuitry examples of PNP inputs	2-17
2.3.6 Circuitry examples of NPN inputs	2-20
2.3.7 Connecting the input module	2-23
2.4 Instructions on commissioning	2-25

2.5	Technical specifications	2-29
3.	Output modules type CP-A08...-M12-...	3-1
3.1	Summary	3-3
3.2	Fitting	3-4
3.3	Installation	3-5
3.3.1	Connecting the actuators	3-6
3.3.2	Connecting the output module	3-13
3.3.3	Connecting the load voltage	3-14
3.4	Instructions on commissioning	3-17
3.5	Technical specifications	3-20
A.	Index	A-1

Designated use

The CP modules described in this manual are intended exclusively for use on a CP string, an axis interface string or a CP branch line in conjunction with a CP field bus node, the Smart Positioning Controller type SPC200 or the Powerbox type CP-FB-TBOX-SUBD9. CP modules and CP cables are only to be used as follows:

- in accordance with designated use
- in its/their original state
- without any modifications by the user
- in faultless technical condition.

When used together with commercially available components, such as sensors and actuators, the specified limits for pressures, temperatures, electrical data, torques etc. must be observed. National and local safety regulations must also be observed. All CP modules comply with protection class III.



Warning

- Use only PELV **circuits** as per IEC/DIN EN 60204-1 (Protective Extra-Low Voltage, PELV) for the electrical supply. Consider also the general requirements for PELV circuits in accordance with IEC/DIN EN 60204-1.
- Use power **supplies** which guarantee reliable electrical isolation of the operating voltage as per IEC/DIN EN 60204-1.

Target group

This manual is directed exclusively at technicians trained in control and automation technology.

Service

Please consult your local Festo repair service if you have any technical problems.

Important user instructions

Danger categories

This manual contains instructions on the possible dangers which may occur if the product is not used correctly. These instructions are marked (Warning, Caution, etc), printed on a shaded background and marked additionally with a pictogram. A distinction is made between the following danger warnings:



Warning

This means that failure to observe this instruction may result in serious personal injury or damage to property.



Caution

This means that failure to observe this instruction may result in personal injury or damage to property.



Please note

This means that failure to observe this instruction may result in damage to property.

The following pictogram marks passages in the text which describe activities with electrostatically sensitive components.



Electrostatically sensitive components may be damaged if they are not handled correctly.

Marking special information

The following pictograms mark passages in the text containing special information.

Pictograms



Information:
Recommendations, tips and references to other sources of information.



Accessories:
Information on necessary or sensible accessories for the Festo product.



Environment:
Information on environment-friendly use of Festo products.

Text markings

- The bullet indicates activities which may be carried out in any order.
- 1. Figures denote activities which must be carried out in the numerical order specified.
- Hyphens indicate general activities.

Notes on the use of this manual

CP I/O modules are available in the designs PNP (positive-switching) and NPN (negative-switching). The positive-switching modules with M12 connectors are available in 4-pin and 5-pin designs. The 5-pin design offers an earthing connection. This manual contains general basic information on the method of operation, and on fitting, installing and commissioning CP systems.

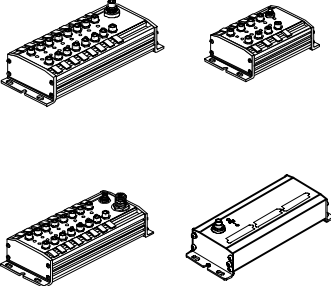
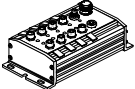
This manual refers to:	
	<p>Input modules</p> <p>PNP:</p> <ul style="list-style-type: none"> – CP-E16-M8 – CP-E16-M12x2 – CP-E16-M12x2-5POL <p>NPN:</p> <ul style="list-style-type: none"> – CP-E16N-M8 – CP-E16N-M12x2 <p>PNP or NPN:</p> <ul style="list-style-type: none"> – CP-E16-M8-Z – CP-E16-KL-IP20-Z
	<p>Output modules</p> <p>PNP:</p> <ul style="list-style-type: none"> – CP-A08-M12 – CP-A08-M12-5POL <p>NPN:</p> <ul style="list-style-type: none"> – CP-A08N-M12

Information on further modules, as well as basic information which must be observed in conjunction with the higher-order system, can be found in the manuals for the relevant systems.









Manuals on the CP system			Peripherals
Manual	“CP system, installation and commissioning” type P.BE-CPSYS-... 		
Contents	General basic information on the method of operation, fitting, installation and commissioning of CP systems.		
Manual	“CP field bus node, programming and diagnosis” type P.BE-CP-FB... or P.BE-VIFB...-10... 	“CPV valve terminal, pneumatics” or “CPA valve terminal, pneumatics” type P.BE-CPV-... or P.BE-CPA-... 	“CP modules, electronics” type P.BE-CPEA-... 
Contents	Special information on commissioning, programming and diagnosing related to the node used.	Information on fitting, installing and commissioning CPA or CPV valve terminals	Information on fitting, installing and commissioning CP I/O modules
			

Fig. 0/1: Manuals on the CP system

Manuals on the SPC200 Smart Positioning Controller			Peripherals
Manuals	SPC200 Smart Positioning Controller, User manual type P.BE-SPC200-... 	Manual WinPISA type P.SW-WIN-PISA-... 	Manuals on: – proportional directional control valves – service unit – position measuring system – cylinder or linear drives
Contents	Installation, commissioning and diagnosis with SPC200; standard components and modules	Functions of the WinPISA software package	
Description	CPV valve terminal pneumatics type P.BE-CPV-... 	CP modules electronics type P.BE-CPEA-... 	
Contents	Information on the CPV valve terminals	Information on the CP I/O modules	

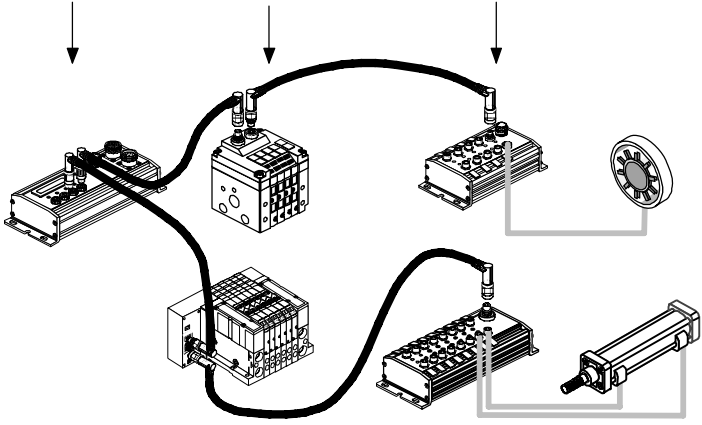
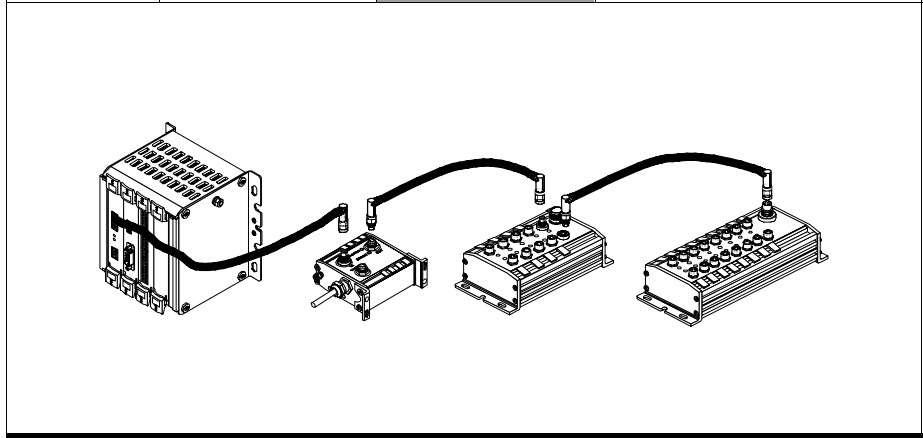

Fig. 0/2: Manuals on the SPC200

Input modules type CP-E16...-M...-...

Chapter 1

1. Input modules type CP-E16...-M...-...

Contents

1.	Input modules type CP-E16...-M...-...	1-1
1.1	Function of input modules type CP-E16...-M...-...	1-3
1.1.1	Display and connecting elements	1-4
1.2	Fitting	1-6
1.3	Installation	1-10
1.3.1	Determining PNP or NPN operation (only with type CP-E16-M8-Z)	1-11
1.3.2	Connecting the separate power supply for the sensors (only with type CP-E16-M8-Z) 1-12	
1.3.3	Connecting the sensors	1-15
1.3.4	Connecting the input module	1-26
1.4	Instructions on commissioning	1-28
1.5	Technical specifications	1-33

1. Input modules type CP-E16...-M...-...

1.1 Function of input modules type CP-E16...-M...-...

CP input modules provide digital inputs for connecting sensors and enable e.g. cylinder positions to be scanned. A distinction is made between the following types:

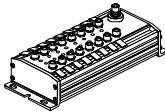
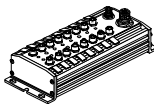
Type	Explanation
CP-E16-M12x2-... 	Provides 16 PNP inputs; sensor connections via 8 sockets with M12 thread
CP-E16N-M12x2	Provides 16 NPN inputs; sensor connections via 8 sockets with M12 thread
CP-E16-M8 	Provides 16 PNP inputs; sensor connections via 16 sockets with M8 thread
CP-E16N-M8	Provides 16 NPN inputs; sensor connections via 16 sockets with M8 thread
CP-E16-M8-Z 	Provides 16 PNP or 16 NPN inputs and has its own connection for supplying the sensor voltage

1. Input modules type CP-E16...-M...-...

1.1.1 Display and connecting elements

The diagram below shows, as an example, the display and connecting elements on the input module type CP-E16...-M12x2.

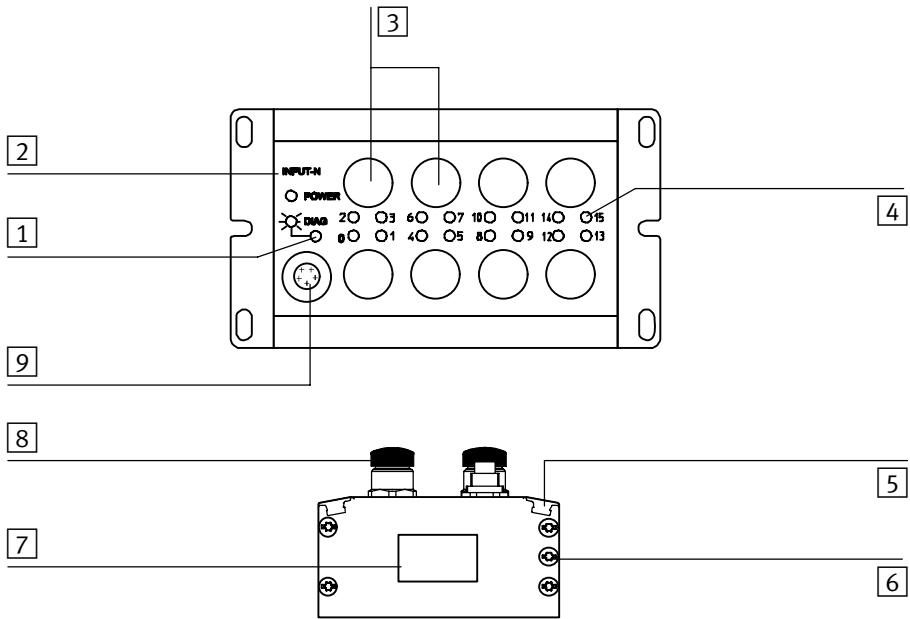

- | | |
|--|--|
| 1 Status LED (green) | 5 Groove for identification signs (IBS 6x10) |
| 2 Identification for input type:
– INPUT-P for PNP inputs
– INPUT-N for NPN inputs | 6 Earth/ground connection |
| 3 Sensor connections | 7 Type plate |
| 4 Yellow LED for status display (one LED per input) | 8 Protective cap |
| | 9 CP connection |

Fig. 1/1: Display and connecting elements

1. Input modules type CP-E16...-M...-...

The diagram below shows the additional display and operating elements on the input module type CP-E16-M8-Z.

- 1 Connection for the power supply to the sensors
- 2 Red LED for displaying short circuits or failure of the sensor voltage (one LED per input group)

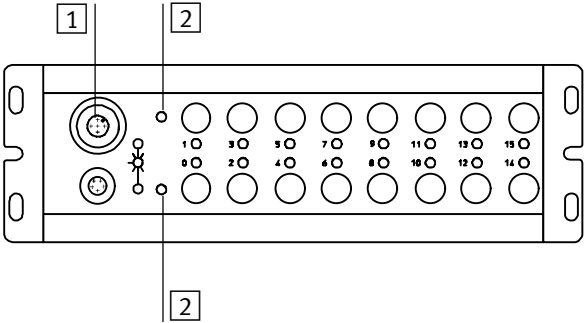

Fig. 1/2: Additional elements of type CP-E16-M8-Z

1. Input modules type CP-E16...-M...-...

1.2 Fitting

Input modules are intended for fitting onto a wall or a hat rail. If you are fitting the module onto a wall, you will require the following space:

Type	Mounting area
CP-E16...-M8	approx. 150 x 66 mm
CP-E16-M8-Z	approx. 217 x 66 mm
CP-E16...-M12x2-...	approx. 141 x 78 mm

Fitting onto a wall

The diagram below shows the dimensions for the four threaded holes of M4 screw size.

1. Input modules type CP-E16...-M...-...

- 1 Input module, type CP-E16...-M12x2-...
- 2 Input module, type CP-E16...-M8
- 3 Input module, type CP-E16-M8-Z

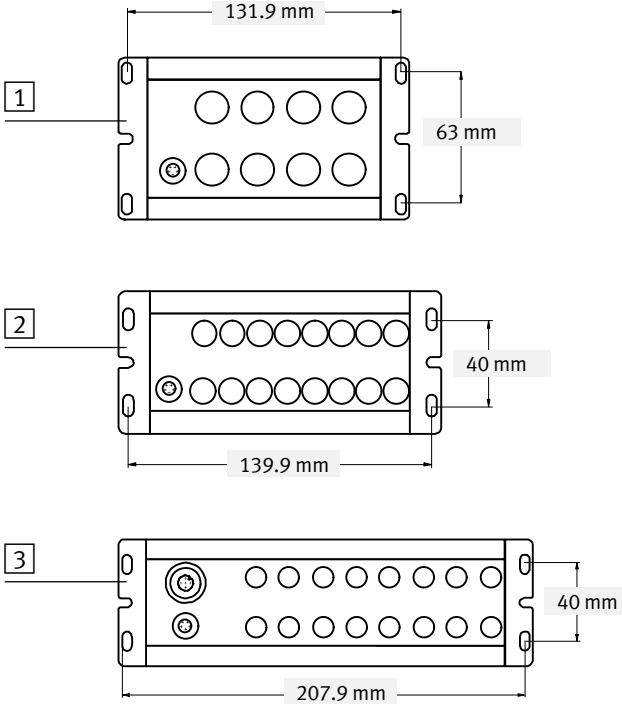

Fig. 1/3: Mounting dimensions for CP-E16...-M...-...

1. Input modules type CP-E16...-M...-...



In order to fit the module onto a hat rail, you will require fastening kit CP-TS-HS35. This kit consists of 2 fastenings, 2 M4x12 screws and two washers.

Fitting onto a hat rail

Proceed as follows when fitting the modules onto a hat rail:

1. Make sure that the mounting surface can support the weight of the node.
2. Fit a hat rail (support rail as per EN 50022 - 35x15; width 35 mm, height 15 mm).
3. Fasten the hat rail to the fastening surface at intervals of at least every 100 mm.
4. Let both fastenings on the hat rail snap into place (see Fig. 1/4).
5. Fasten the housing to the fastening with the screws supplied, as shown in the diagram below.
6. Tighten the screws. The fastening and the housing will then be clamped firmly on the hat rail.

1. Input modules type CP-E16...-M...-...

- 1 Fastening
- 2 Housing
- 3 M4x12 screw
- 4 Washer
- 5 Hat rail

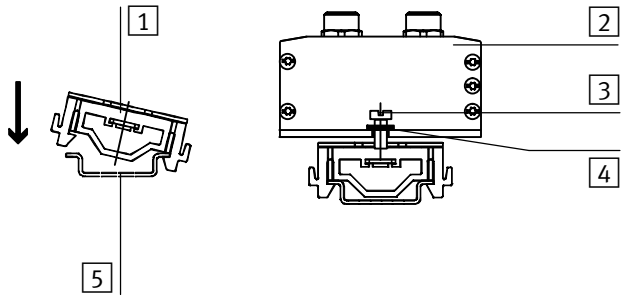

Fig. 1/4: Fitting onto a hat rail

Proceed with dismantling as follows:

1. Loosen the screws.
2. Remove the housing.
3. Lift the fastening out of the hat rail with a screwdriver.

- 1 Screwdriver
- 2 Fastening

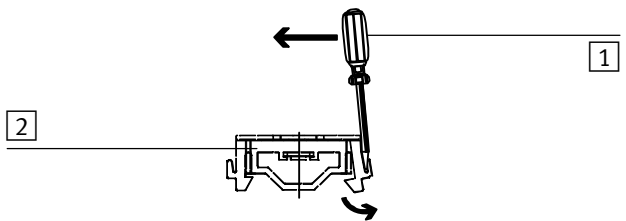

Fig. 1/5: Dismantling the fastening

1. Input modules type CP-E16...-M...-...

1.3 Installation



Warning

Before carrying out installation and maintenance work, switch off the following:

- the operating and load voltages on the higher-order system (e.g. CP field bus node)
- if necessary, the separate supply voltages.

You can thereby avoid:

- unexpected movements of the connected actuators
- non-defined switching states of the electronic components.



Warning

Connect the earth connection on the side of the housing (see Fig. 1/1) with low impedance (short cable with large cross-sectional area) to the earth potential.

In this way you can avoid faults due to electromagnetic influences and ensure electromagnetic compatibility in accordance with EMC guidelines.

1. Input modules type CP-E16...-M...-...

1.3.1 Determining PNP or NPN operation (only with type CP-E16-M8-Z)

Input module type CP-E16-M8-Z provides PNP or NPN inputs. You can determine either PNP or NPN operation by installing a bridge in the socket of the sensor supply connection. The following views show the rear of the socket.

- 1 Pin assignment
 - 1: + 24 V DC
± 25 %
 - 2: PNP/NPN
 - 3. 0 V
 - 4: not connected
 - 5: earth/ground connection
- 2 PNP operation
(pins 2 and 3 bridged)
- 3 NPN operation
(pins 2 and 1 bridged)

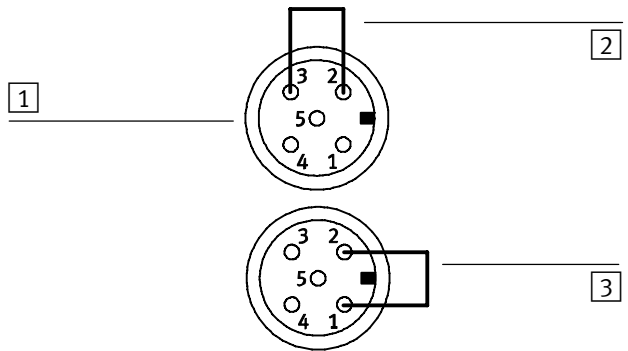

Fig. 1/6: Determining PNP or NPN operation (only with type CP-E16-M8-Z)

1. Input modules type CP-E16...-M...-...

1.3.2 Connecting the separate power supply for the sensors (only with type CP-E16-M8-Z)



Warning

- Use only PELV **circuits** as per IEC/DIN EN 60204-1 (Protective Extra-Low Voltage, PELV) for the electrical supply. Consider also the general requirements for PELV circuits in accordance with IEC/DIN EN 60204-1.
- Use power **supplies** which guarantee reliable electrical isolation of the operating voltage as per IEC/DIN EN 60204-1.

By the use of PELV circuits, protection against electric shock (protection against direct and indirect contact) is guaranteed in accordance with IEC/EN 60204-1 (Electrical equipment for machines, General requirements).

The CP input module must be earthed to ensure that it functions correctly (e.g. EMC).

The connected sensors are supplied with + 24 V DC via the connection for the sensor supply. The module enables sensors with high current consumption to be connected (max. 125 mA per sensor).

1. Input modules type CP-E16...-M...-...



The following diagram shows the pin assignment of the connection as well as an example of a connection for PNP operation (bridge between pins 2 and 3). See “Determining PNP or NPN operation”, section 1.3.1.

- 1 Pin assignment
 - 1: + 24 V DC $\pm 25\%$
 - 2: PNP/NPN
 - 3: 0 V
 - 4: not connected
 - 5: earth/ground connection

- 2 The sensor voltage can be switched off separately; the operating voltage is supplied via the CP connection

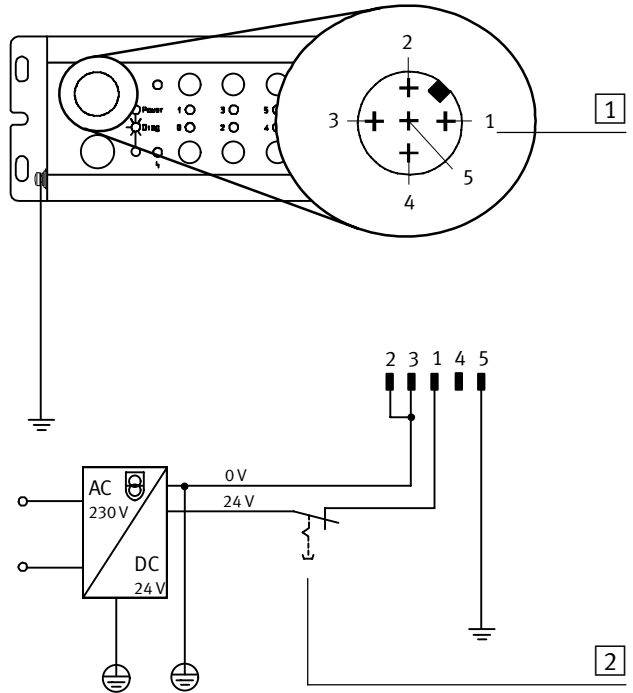

Fig. 1/7: Pin assignment and connection example of the sensor supply (PNP operation)

1. Input modules type CP-E16...-M...-...

Potential equalization

The CP module has two earthing connections for potential equalization:

- on the connection for the sensor voltage supply (pin 5).
- on the housing (earthing connection see Fig. 1/7).



Please note

- Always connect the earth potential to pin 5 of the sensor supply voltage.
- Connect the earth connection on the left-hand side of the housing with low impedance (short cable with large cross-sectional area) to the earth potential.
- With low-impedance connections you can ensure that the housing of the module and the earth connection at pin 5 have the same potential and that there are no equalizing currents.

In this way you can avoid faults due to electromagnetic influences and ensure electromagnetic compatibility in accordance with EMC guidelines.

1. Input modules type CP-E16...-M...-...

1.3.3 Connecting the sensors



Caution

If you are using input module type CP-E16-M8-Z, make sure that pin 2 of the sensor supply connection is bridged in accordance with the operating method of your system (either PNP or NPN operation, see section 1.3.1).



Use the following cables or plugs for connecting the sensors:

Type	Plugs	Cable
CP-E16...-M12x2	SEA-GS-7 (PG7) SEA-WS-7 (PG7)	KM12-DUO-...
CP-E16-M12x2-5POL	Use plugs with union nuts with M12x1 thread.	
CP-E16...-M8 and CP-E16-M8-Z	Use plugs with union nuts with M8x1 thread (outer diameter max. 12 mm).	KM8-M8-GSGD-...

Fasten the plugs with the aid of the union nut in order to prevent unintentional loosening, e.g. due to shock. Seal the unused sensor connections with the protective caps supplied. Only in this way can you comply with protection class IP 65.

1. Input modules type CP-E16...-M...-...

Pin assignment (PNP and NPN inputs)

The diagrams below show, as an example, the pin assignment of the sensor connections of the various CP input modules.

Pin assignment

- 1: 24 V
4: Ex+1
3. 0 V

- 1: 24 V
4: Ex
3. 0 V

Ex = Input x

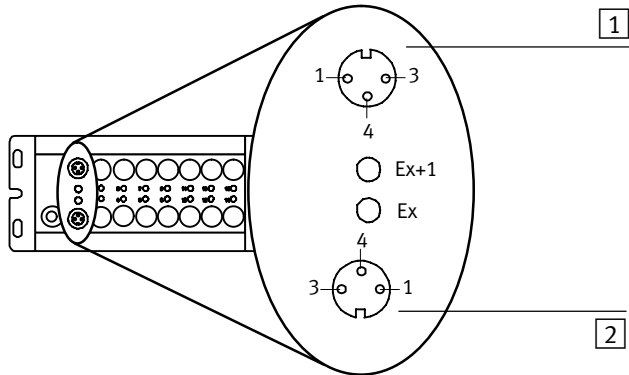

Fig. 1/8: Pin assignment of type CP-E16...-M8 and CP-E16-M8-Z

Pin assignment

- 1: 24 V
2: Ex+1
3. 0 V
4: Ex + 2

- 1: 24 V
2: Ex+1
3. 0 V
4: Ex

Ex = Input x

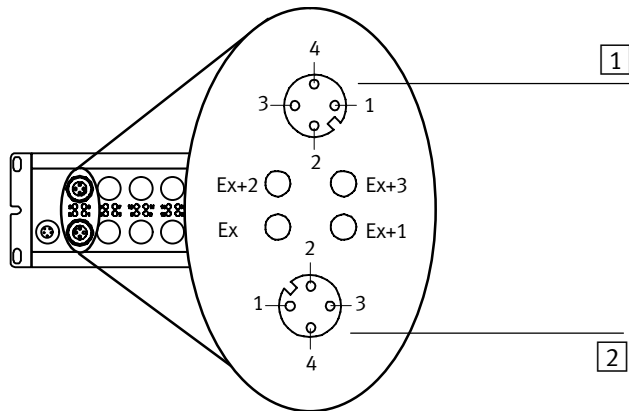
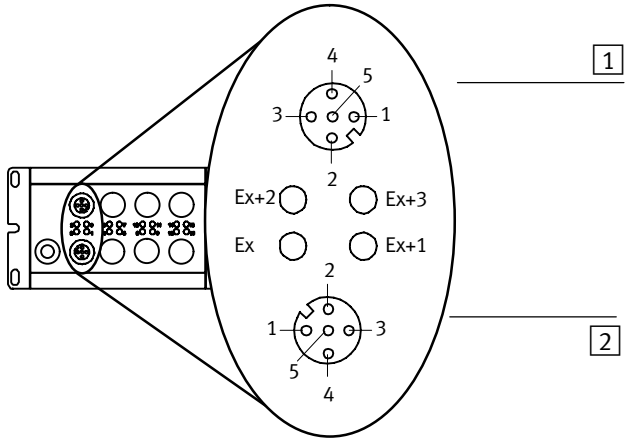

Fig. 1/9: Pin assignment of type CP-E16...-M12x2

1. Input modules type CP-E16...-M...-...

Pin assignment

- 1** 1: 24 V
 - 2: Ex+3
 - 3. 0 V
 - 4: Ex+2
 - 5: earth/ground connection
-
- 2** 1: 24 V
 - 2: Ex+1
 - 3. 0 V
 - 4: Ex
 - 5: earth/ground connection



Ex = Input x

Fig. 1/10: Pin assignment of type CP-E16-M12x2-5POL

1. Input modules type CP-E16...-M...-...

Internal structure of CP-E16-M8 (PNP inputs) and CP-E16-M8-Z with PNP operation

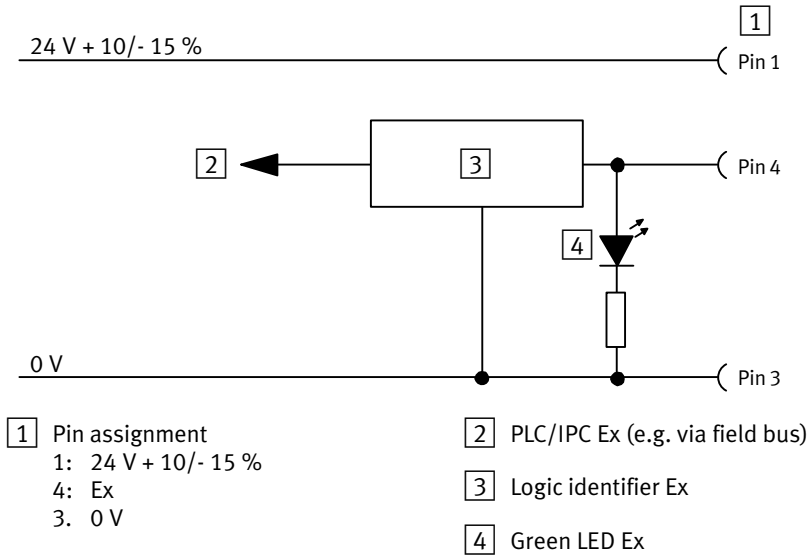

Ex = Input x

Fig. 1/11: Internal structure

1. Input modules type CP-E16...-M...-...

Circuitry examples of CP-E16-M8 (PNP inputs) and CP-E16-M8-Z with PNP operation

- 1 Pin assignment
3. 24 V
4: Ex
3. 0 V
 - 2 Three-wire sensor (positive-switching)
 - 3 Two-wire sensor (positive-switching)
 - 4 Contact
- Ex = Input x

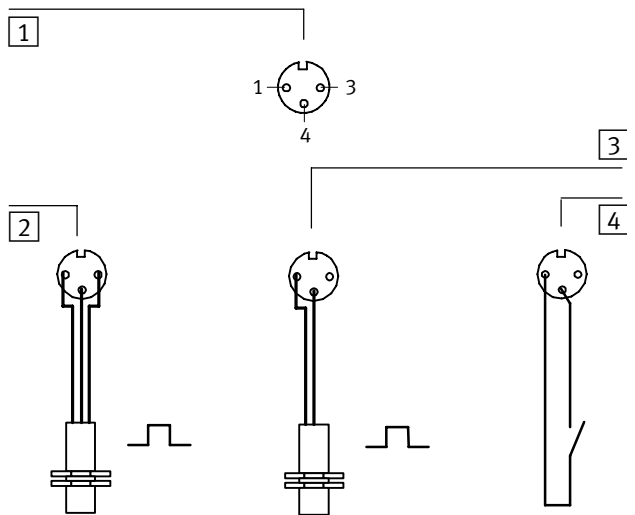
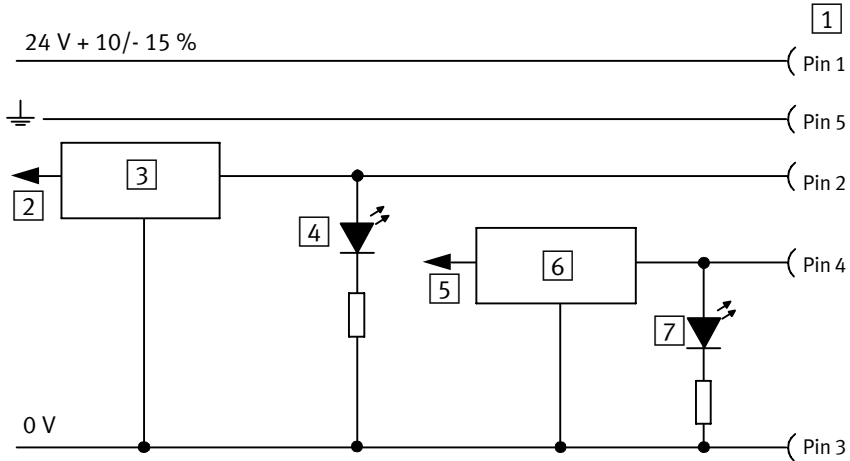

Fig. 1/12: Circuitry examples

1. Input modules type CP-E16...-M...-...

Internal structure of CP-E16-M12x2-... (PNP inputs)



- 1 Pin assignment
 - 1: + 24 V + 10/- 15 %
 - 2: Ex+1
 - 3. 0 V
 - 4: Ex
 - 5: Earth connection only with type CP-E16-M12x2-5POL
- 2 PLC/IPC Ex+1 (e.g. via field bus)

- 3 Logic identifier Ex+1
- 4 Green LED Ex+1
- 5 PLC/IPC Ex (e.g. via field bus)
- 6 Logic identifier Ex
- 7 Green LED Ex

Ex = Input x

Fig. 1/13: Internal structure

1. Input modules type CP-E16...-M...-...

Circuitry examples of CP-E16-M12x2... (PNP inputs)

1 Pin assignment

- 3. 24 V
- 2: Ex +1
- 3. 0 V
- 4: Ex
- 5: *)

2 Sensor 2 (Ex+1) positive switching

3 2-way distributor (T-piece)

4 Sensor 1 (Ex) positive switching

*) Only with type CP-16-M12x2-5POL earth/ground connection

Ex = Input x

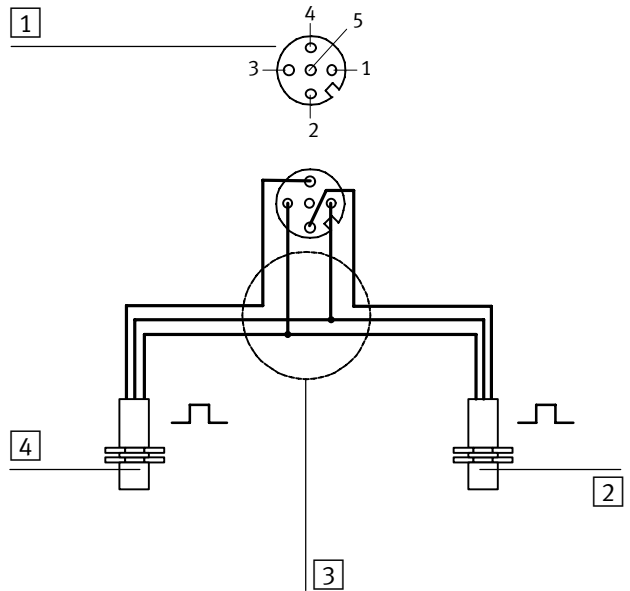
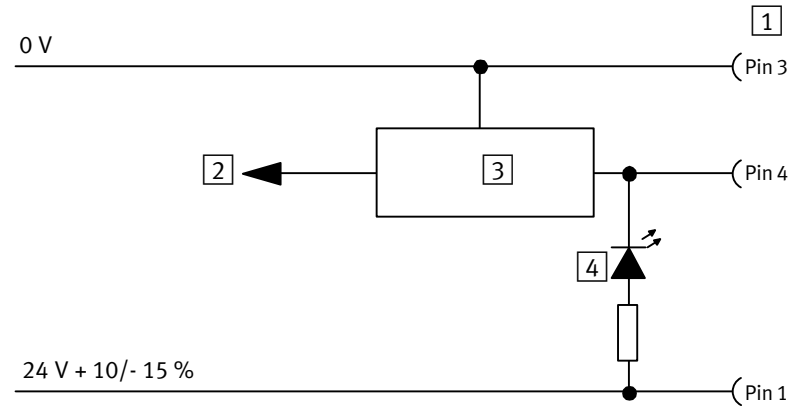

Fig. 1/14: Circuitry examples

1. Input modules type CP-E16...-M...-...

Internal structure of CP-E16N-M8 (NPN inputs) and CP-E16-M8-Z with NPN operation



- 1** Pin assignment
1: 24 V + 10/- 15 %
4: Ex
3. 0 V
- 2** PLC/IPC Ex (e.g. via field bus)
- 3** Logic identifier Ex
- 4** Green LED Ex

Ex = Input x

Fig. 1/15: Internal structure

1. Input modules type CP-E16...-M...-...

Circuitry examples of CP-E16N-M8 (NPN inputs) and CP-E16-M8-Z with NPN operation

1 Pin assignment

3. 24 V

4: Ex

3. 0 V

2 Three-wire sensor
(negative-switching)

3 Two-wire sensor
(negative-switching)

4 Contact

Ex = Input x

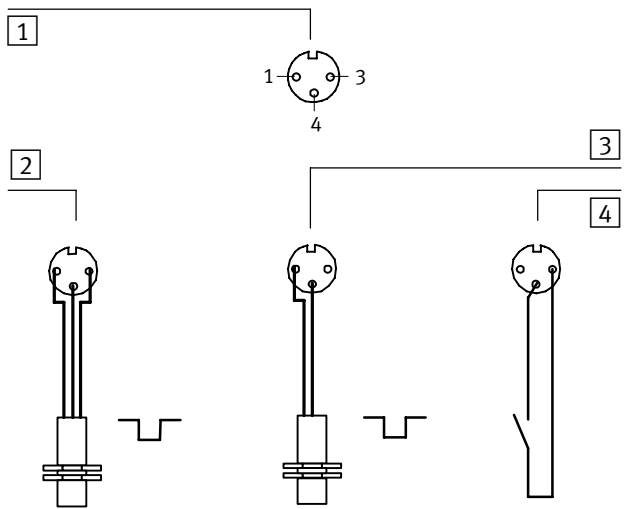
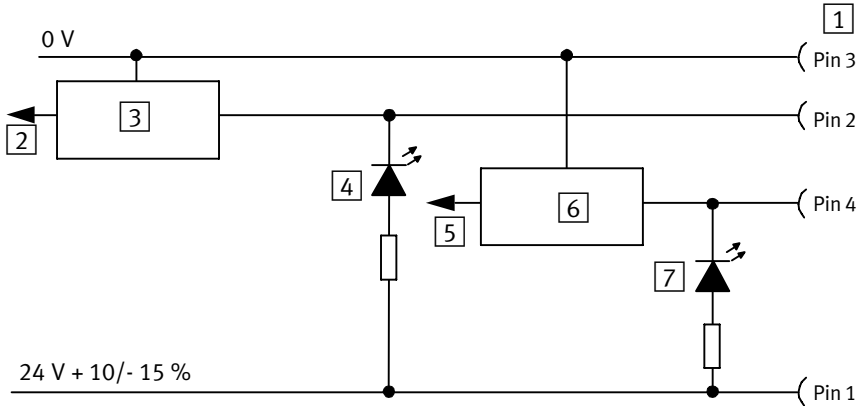

Fig. 1/16: Circuitry examples

1. Input modules type CP-E16...-M...-...

Internal structure of CP-E16N-M12x2 (NPN inputs)



- 1** Pin assignment
 - 1: + 24 V + 10/- 15 %
 - 2: Ex+1
 - 3. 0 V
 - 4: Ex

- 2** PLC/IPC Ex+1 (e.g. via field bus)

Ex = Input x

- 3** Logic identifier Ex+1
- 4** Green LED Ex+1
- 5** PLC/IPC Ex (via field bus)
- 6** Logic identifier Ex
- 7** Green LED Ex

Fig. 1/17: Internal structure

1. Input modules type CP-E16...-M...-...

Circuitry examples of CP-E16N-M12x2 (NPN inputs)

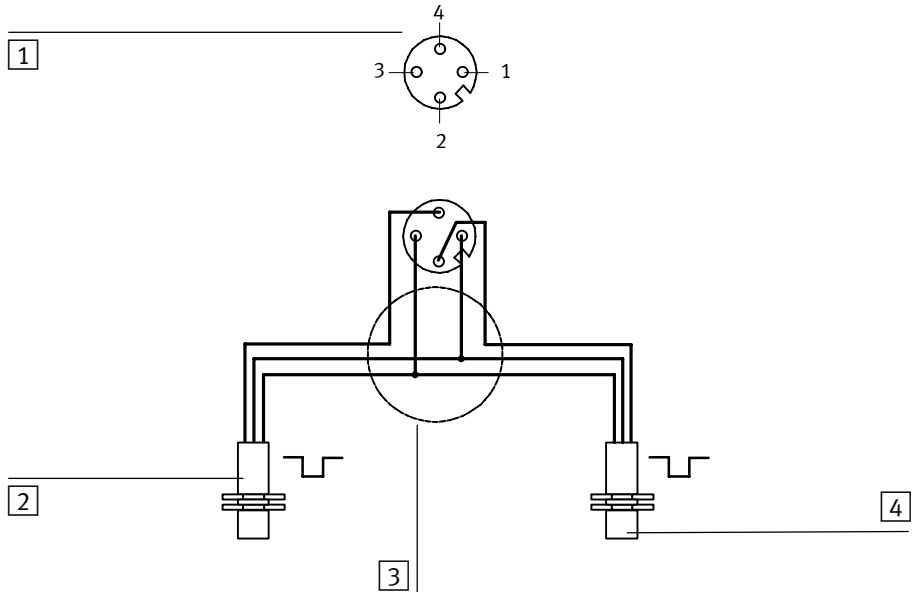

1 Pin assignment

1. 24 V
- 2: Ex+1
3. 0 V
- 4: Ex

2 Sensor 2 (Ex+1) (negative logic)

3 2-way distributor (T-piece, e.g. Festo Duo cable; only 4-pin)

4 Sensor 1 (Ex) (negative logic)

Ex = Input x

Fig. 1/18: Circuitry examples

1. Input modules type CP-E16...-M...-...

1.3.4 Connecting the input module



Caution

Please observe the maximum permitted string lengths. You can thereby avoid errors in data exchange between the input module and the higher-order system (e.g. field bus node).

Use only the following original cables for connecting the modules:

For connection to:	max. permitted string length	Cable type
Field bus node with CP connection	10 m	– KVI-CP-1-... or – KVI-CP-2-... (suitable for drag chain)
Axis interface type SPC-AIF-...	See manual for the SPC200 type P.BE-SPC200-...	
Powerbox type CP-FB-TBOX-...	See manual for the higher-order system	

The following functions are provided for the module via the CP cable:

- Operating voltage for the internal electronics
- Connection for data exchange
- in the case of input modules without connection for supplying the sensors:
Operating voltage for the connected sensors.

1. Input modules type CP-E16...-M...-...

Input modules should be connected to one of the following:

- to the CP connection of the higher-order system (field bus node or axis interface or Powerbox)
- to the CP connection of a CP output module
- to the CP connection of a valve terminal.

Further information can be found in the relevant system manual.

1. Input modules type CP-E16...-M...-...

1.4 Instructions on commissioning



Warning

Please be careful if the string assignment is modified at a later stage. After saving the string assignment/hardware configuration, check the address assignments of your higher-order system before starting user programs.

You can thereby avoid:

- addressing errors with unintentionally incorrectly fitted CP modules.





When the string assignment on CP field bus nodes has been modified (CP modules added or removed), you must save the new string assignment by pressing the SAVE button on the node. Proceed here as described in the manual “CP system, installation and commissioning”.

When the string assignment has been modified on the SPC200, the new hardware configuration must also be saved. Proceed here as described in the manual for the SPC200 or in the WinPISA manual.

Status LED

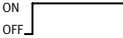
The operating status of the input module is indicated by the status LED on the CP connection (see table below).

1. Input modules type CP-E16...-M...-...

Status LED	Sequence	Operating status	Error treatment
 LED lights up		Operating voltage applied	None
 LED is out		<ul style="list-style-type: none"> – Operating voltage not applied or no connection to the higher-order system or In conjunction with the CP node: <ul style="list-style-type: none"> – incorrect string assignment ascertained during operation In conjunction with the SPC200: <ul style="list-style-type: none"> – see user manual for the SPC200 	<ul style="list-style-type: none"> • Check the CP cable and the operating voltage connection on the higher-order system or • correct string assignment • see user manual type P.BE-SPC200
 LED flashes		<ul style="list-style-type: none"> – Test phase when power supply has been switched on or – short circuit in sensor supply³⁾ or With type CP-E16-M8-Z: <ul style="list-style-type: none"> – undervoltage in sensor supply (< 17 V) or In conjunction with the CP node: <ul style="list-style-type: none"> – incorrect string assignment when operating voltage is switched on In conjunction with the SPC200: <ul style="list-style-type: none"> – see user manual for the SPC200 	<ul style="list-style-type: none"> • None or • eliminate short circuit and, if applicable, delete error¹⁾ or • eliminate undervoltage • check string assignment²⁾ • see user manual type P.BE-SPC200
<p>¹⁾ With type CP-E16-M8-Z the error will be deleted automatically. With other modules the error will be deleted when the input module is disconnected from the string or when the power supply is switched on again on the higher-order system.</p> <p>²⁾ When the string assignment on CP field bus nodes has been modified (CP modules added or removed), you must save the new string assignment by pressing the SAVE button on the node (see Manual for the “CP system, installation und commissioning”).</p> <p>³⁾ With type CP-E16-M8-Z the short circuit LED on the relevant input group will light up.</p>			

1. Input modules type CP-E16...-M...-...

Short circuit in the sensor supply on input module type CP-E16-M8-Z

If there is a short circuit, the input module will switch off the power supply for the relevant input group and pass the error on to the higher-order system. The short circuit LED of the relevant input group lights up.

- 1 Input group 1 (upper row)
- 2 Input group 2 (lower row)
- 3 Red LED for displaying short circuits or failure of the sensor voltage (one LED per input group)

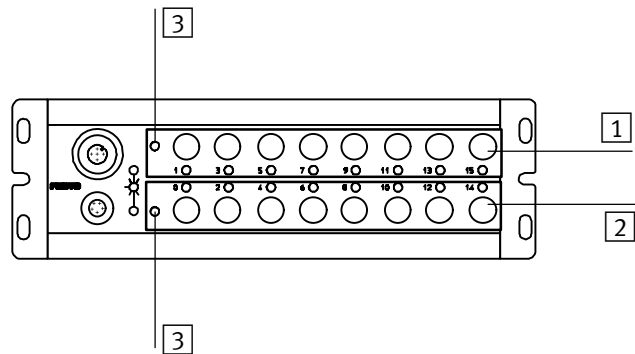

Fig. 1/19: Short circuit displays with type CP-E16-M8-Z

The status LEDs of the relevant input group are switched off and the relevant inputs supply a 0-signal. The other input group remains ready to operate. When the short circuit is eliminated, the error will be deleted automatically.

1. Input modules type CP-E16...-M...-...

Short circuit in the sensor supply on input modules without sensor supply connection

If there is a short circuit, the input module will switch off the power supply for the sensors self-holding and pass the error on to the higher-order system. The status LEDs will be switched off and the inputs of the module supply a 0-signal. When the short circuit has been eliminated, delete this error as follows:

In conjunction with the CP node:

- Disconnect the input module briefly from the string or
- switch the operating voltage off and then on again.

In conjunction with the SPC200:

- For procedure see user manual type P.BE-SPC200

Replacing CP modules

If a fault occurs on a CP module during operation, you can replace the module during operation by another module of the same type.









Please note

Please note here the instructions in the manual for the higher-order system (e.g. CP system, CP field bus node, SPC200).

1. Input modules type CP-E16...-M...-...

Status display

There are one or two green LEDs next to the sensor connections. These indicate the status of the signal at the relevant output. The LEDs indicate the following:

Status LED	Sequence	Status
 LED lights up		logical 1 (signal present)
 LED is out		logical 0 (no signal)
 LED flashes		Only in the start-up phase when: – there is a 1-signal and – there is a string assignment error



Please note

in conjunction with the CP field bus node:

If there is a string assignment error during the start-up phase, the CP node will switch the power supply for the input module, and thereby also for the connected sensors, cyclically on and off. In this case, therefore, the status LEDs and the LEDs of the connected sensors will flash, providing there is a signal (logical 1).

1. Input modules type CP-E16...-M...-...

1.5 Technical specifications

General technical specifications	Type CP-E16...-...
Temperature range: – Operation – Storage/transport	- 5 °C ... + 50 °C - 20 °C ... + 70 °C
Relative humidity	95 % non-condensing
Protection class as per EN 60529; plug connector inserted or provided with protective cap	IP65
Protection against electric shock as per EN 60204-1 / IEC 204	(protection against direct and indirect contact) by connection to a PELV power unit (Protected Extra Low Voltage)
Electromagnetic compatibility – Interference emitted – Immunity against interference	Tested as per EN 55011, limit class B Tested as per EN 50082-2
Vibration and shock – Vibration – Shock	Tested as per DIN/IEC 68/EN 60068 part 2-6; severity class 2 Tested as per DIN/IEC 68/EN 60068 part 2-27; severity class 2

1. Input modules type CP-E16...-M...-...

Special technical data	Type CP-E16-M8-Z; positive switching (PNP) – or negative switching (NPN) operation
Digital inputs – Design	16 inputs as per IEC 1131-2 type 2 inputs 24 V DC, positive or negative switching
– Logic level, positive switching ON OFF – Logic level negative switching ON OFF	PNP (reference 0 V): ≥ 8.6 V ≤ 6 V PNP (reference 24 V): ≤ 6 V ≥ 8.6 V
– Current consumption (at 24 V) (input current from sensor to input)	At “logical 1” typ. 8 mA
– Response delay (at 24 V)	Typ. 3 ms
Sensor supply V_D 24 V ± 25 %	Max. 1 A per input group (electronic short-circuit protection per group)
Electrical isolation	None
Internal current consumption of electronics	< 40 mA

1. Input modules type CP-E16...-M...-...

Special technical data	Positive-switching input modules (PNP) without separate sensor supply connection	
	Type CP-E16-M8 and type CP-E16-M12x2	Type CP-E16-M12x2-5POL
Digital inputs – Design	16 inputs as per IEC 1131-2 Type 2 inputs 24 V DC positive-switching	16 inputs as per IEC 1131-2 Type 2 inputs 24 V DC negative-switching
– Logic level ON OFF	> 11 V < 5 V	≥ 8.6 V ≤ 6 V
– Current consumption (at 24 V) (input current from sensor to input)	At "logical 1" typ. 8 mA	At "logical 1" typ. 6 mA
– Response delay (at 24 V)	Typ. 5 ms	Typ. 3 ms
Sensor supply V_D 24 V ± 25 %	Max. 0.5 A (electronic short-circuit protection)	
Electrical isolation	None	
Internal current consumption of electronics	< 40 mA	Max. 90 mA

1. Input modules type CP-E16...-M...-...

Special technical data	Negative-switching input modules (NPN) Type CP-E16N-M8 and type CP-E16N-M12x2
Digital inputs – Design	16 inputs as per IEC 1131-2 type 2 inputs 24 V DC negative-switching
– Logic level ON OFF	< V_D - 11 V > V_D - 5 V
– Current consumption (at 24 V) (input current from sensor to input)	At “logical 0” typ. 8 mA
– Response delay (at 24 V)	Typ. 5 ms
Sensor supply V_D 24 V \pm 25 %	Max. 0.5 A (electronic short-circuit protection)
Electrical isolation	None
Internal current consumption of electronics	Max. 90 mA

Input module type CP-E16-KL-IP20-Z

Chapter 2

2. Input module type CP-E16-KL-IP20-Z

Contents

2.	Input module type CP-E16-KL-IP20-Z	1-1
2.1	Method of operation of input module CP-E16-KL-IP20-Z	2-3
2.1.1	Display and connecting elements	2-4
2.2	Fitting	2-5
2.3	Installation	2-8
2.3.1	Determining PNP or NPN operation	2-9
2.3.2	Connecting the separate power supply for the sensors	2-10
2.3.3	Connecting the sensors	2-13
2.3.4	Pin assignment (PNP and NPN inputs)	2-16
2.3.5	Circuitry examples of PNP inputs	2-17
2.3.6	Circuitry examples of NPN inputs	2-20
2.3.7	Connecting the input module	2-23
2.4	Instructions on commissioning	2-25
2.5	Technical specifications	2-29

2. Input module type CP-E16-KL-IP20-Z

2.1 Method of operation of input module CP-E16-KL-IP20-Z

CP input modules provide digital inputs for connecting sensors and enable e.g. cylinder positions to be scanned.

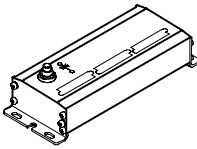
Type	Explanation
<p data-bbox="427 502 588 526">CP-E16-KL-IP20-Z</p> 	<p data-bbox="655 502 1036 598">Input module type CP-E16-KL-IP20-Z provides 16 PNP or 16 NPN inputs and has its own connection for the power supply to the sensors.</p> <p data-bbox="655 606 1024 702">It has three 10-pin optional connecting sockets in screw or tension spring design and is therefore particularly suited for fitting into a control cabinet (IP20).</p>

2. Input module type CP-E16-KL-IP20-Z

2.1.1 Display and connecting elements

The diagram below shows the display and operating elements on input module type CP-E16-KL-IP20-Z.

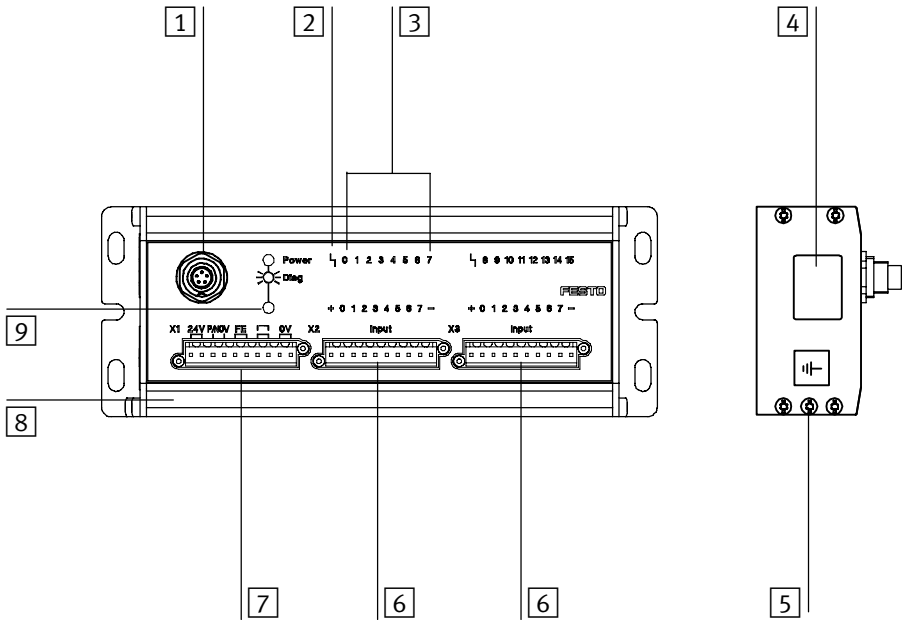

- 4 CP connection
- 5 Red LED for short circuit/overload display (one LED per input module)
- 6 Green LED for status display (one LED per input)
- 7 Type plate
- 8 Earth/ground connection
- 9 Sensor connections (8 inputs per input module)
- 1 Connection for sensor power supply
- 1 1 Groove for identification signs (IBS 6x10)
- 1 2 Status LED (green)

Fig. 2/1: Display and connecting elements

2. Input module type CP-E16-KL-IP20-Z

2.2 Fitting

The input module is intended for fitting onto a wall or a hat rail. If you are fitting the module onto a wall, you will require the following space:

Type	Mounting surface
CP-E16-KL-IP20-Z	Approx. 175 x 66 mm

Fitting onto a wall

The diagram below shows the dimensions for the four threaded holes of M4 screw size. You should fasten the module with at least 3 screws.

1 Input module,
type
CP-E16-KL-IP20-Z

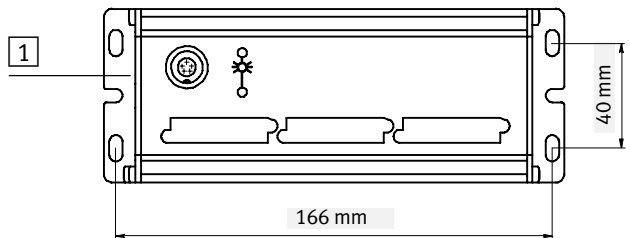

Fig. 2/2: Mounting dimensions for CP-E16...-M...-....

2. Input module type CP-E16-KL-IP20-Z

Hat rail fitting



You will require the following accessories for fitting the module onto a hat rail:

In order to fit the module onto a hat rail, you will require fastening kit CP-TS-HS35. This kit consists of 2 fastenings, 2 M4x12 screws and two washers.

Proceed as follows when fitting the modules onto a hat rail:

1. Make sure that the mounting surface can support the weight of the module.
2. Fit a hat rail (support rail as per EN 50022 - 35x15; width 35 mm, height 15 mm).
3. Fasten the hat rail to the fastening surface at intervals of at least every 100 mm.
4. Let both fastenings snap into place on the hat rail (see Fig. 1/4).
5. Fasten the housing to the fastening with the screws supplied, as shown in the diagram below.
6. Tighten the screws. The fastening and the housing will then be clamped firmly on the hat rail.

2. Input module type CP-E16-KL-IP20-Z

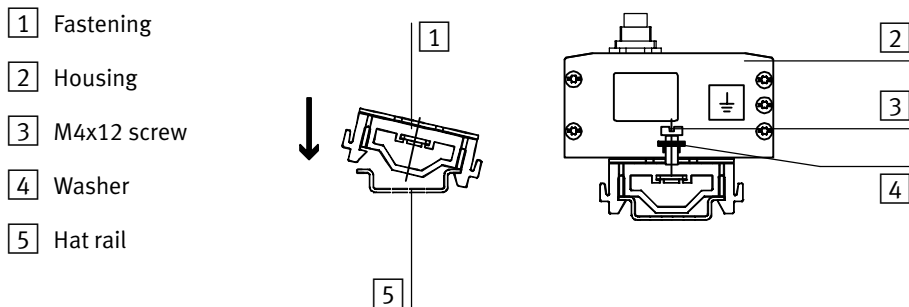

Fig. 2/3: Fitting onto a hat rail

Proceed with dismantling as follows:

1. Loosen the screws.
2. Remove the housing.
3. Lift the fastening out of the hat rail with a screwdriver.

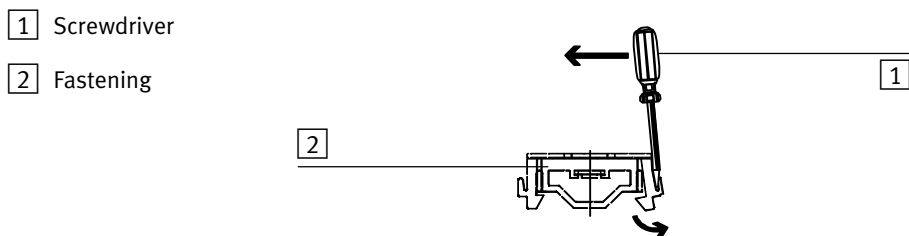

Fig. 2/4: Dismantling the fastening

2.3 Installation



Warning

Undesired movement of the connected actuators and non-defined switching states of the electronics can cause injury to human beings or damage to property.

Before carrying out installation and maintenance work, switch off the following:

- the operating and load voltages on the higher-order system (e. g. CP field bus node)
- separate power supplies.



Warning

Incorrect or missing earthing can cause interference due to electromagnetic influences.

Connect the earth connection on the side of the housing (see Fig. 1/1) with low impedance (short cable with large cross-sectional area) to the earth potential.

You can then guarantee electromagnetic compatibility in accordance with the EMC guidelines.



Caution

Only connection X1 is used for the power supply to the sensors. Do not connect **any** external supply to terminals + and – of X2 and X3. Otherwise the input module may be damaged.

2. Input module type CP-E16-KL-IP20-Z

2.3.1 Determining PNP or NPN operation

Input module type CP-E16-KL-IP20-Z provides PNP or NPN inputs. You can determine either PNP or NPN operation by installing an external bridge in the sensor supply connection.

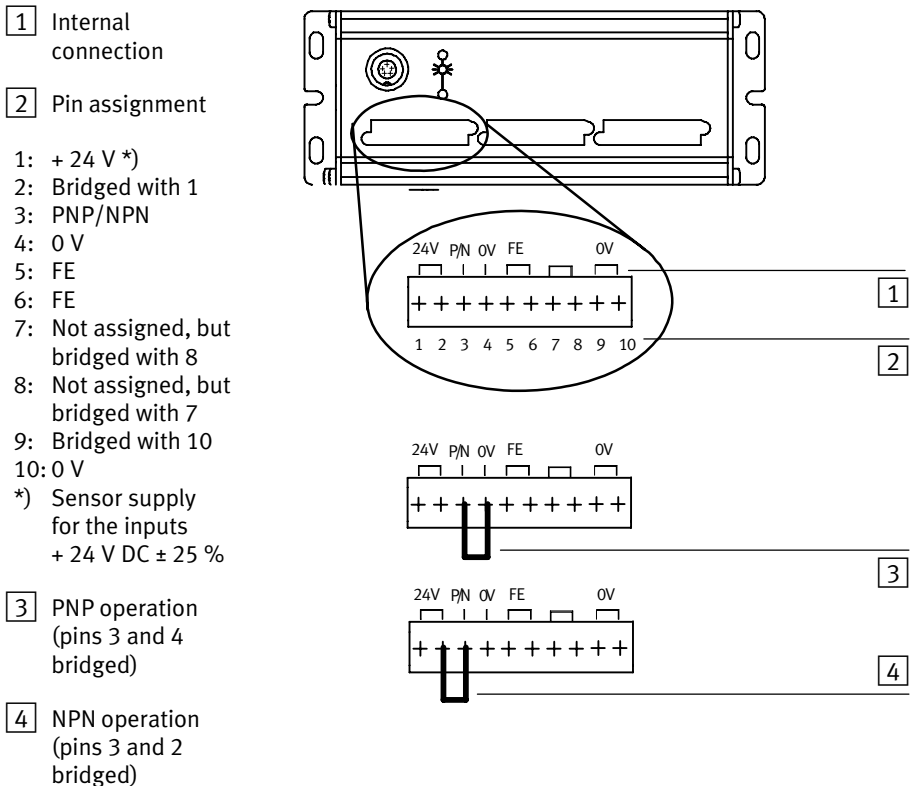

Fig. 2/5: Determining PNP or NPN operation

Internal bridges

A separate load supply for the valves/outputs can be looped through via pins 7 and 8. By means of the other internal bridges (24 V, FE, 0 V), the relevant potential can be passed on to the next CP module.

2. Input module type CP-E16-KL-IP20-Z

2.3.2 Connecting the separate power supply for the sensors



Warning

- Use only PELV **circuits** as per IEC/DIN EN 60204-1 (Protective Extra-Low Voltage, PELV) for the electrical supply. Consider also the general requirements for PELV circuits in accordance with IEC/DIN EN 60204-1.
- Use power **supplies** which guarantee reliable electrical isolation of the operating voltage as per IEC/DIN EN 60204-1.

By the use of PELV circuits, protection against electric shock (protection against direct and indirect contact) is guaranteed in accordance with IEC/EN 60204-1 (Electrical equipment for machines, General requirements).

The CP input module must be earthed to ensure that it functions correctly (e.g. EMC).

The sensors are supplied with + 24 V DC via the connection for the sensor supply. The module enables sensors with high current consumption to be connected (max. 1 A per input module).

2. Input module type CP-E16-KL-IP20-Z



The following diagram shows the pin assignment of the connection as well as an example of a connection for PNP operation (bridge between pins 3 and 4). See also “Determining PNP or NPN operation”, section 1.3.1.

1 Pin assignment

- 1: + 24 V *)
 - 2: Bridged with 1
 - 3: PNP/NPN
 - 4: 0 V
 - 5: FE
 - 6: FE
 - 7: Bridged with 8
 - 8: Bridged with 7
 - 9: Bridged with 10
 - 10: 0 V
- *) Sensor supply
for the inputs
+ 24 V DC \pm 25 %

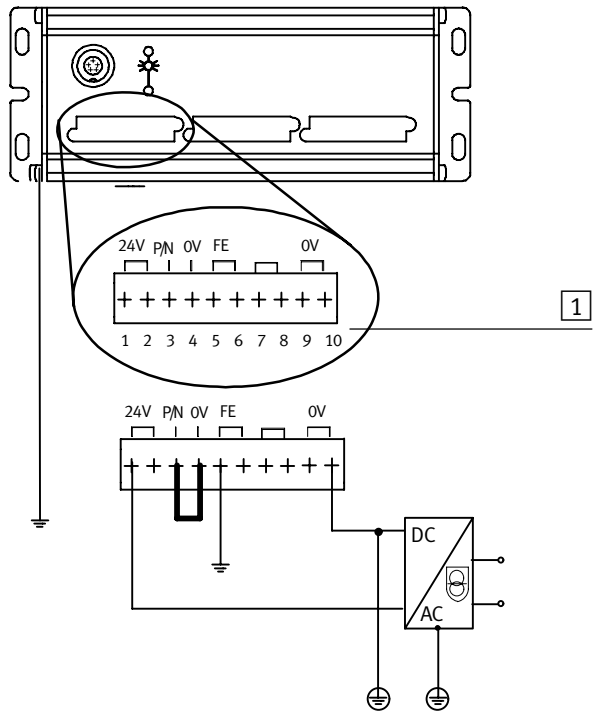

Fig. 2/6: Pin assignment and connection example of the sensor supply (PNP operation)

2. Input module type CP-E16-KL-IP20-Z

Potential equalization

The CP module has two earthing connections for potential equalization:

- on the connection for the sensor voltage supply (pin 5 or 6)
- on the housing (earthing connection see Fig. 1/7).



Please note

- Always connect the earth potential to pin 5 or 6 of the sensor supply voltage.
- Connect the earth connection (FE) on the left-hand side of the housing with low impedance (short cable with large cross-sectional area) to the earth potential.
- With low-impedance connections you can ensure that the housing of the module and the earth connection at pin 5 or 6 have the same potential and that there are no equalizing currents.

In this way you can avoid faults due to electromagnetic influences and ensure electromagnetic compatibility in accordance with EMC guidelines.

2. Input module type CP-E16-KL-IP20-Z

2.3.3 Connecting the sensors



Caution

Long signal cables reduce the immunity to interference. Do not exceed the maximum permitted signal cable length of 30 m.



Caution

Make sure that pin 3 of the sensor supply connection is bridged in accordance with the operating mode of your system (PNP or NPN operation, see section 1.3.1).

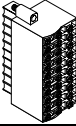

Recommendation: Use the connector sockets from connector set type SEA-KL-SAC10/30.

Sockets in the connector set type SEA-KL-SAC10/30	Number	Connection cross-sectional area	Recommended for connection
Tension spring socket, 1-row 	1	See leaflet with product	X1
Tension spring socket, 3-rows 	2	See leaflet with product	X2, X3

Two rows of the three-row connector socket are intended as distributor boards for the sensor supply. These rows are each connected internally (see Fig. 2/9).

- Fasten these sockets with the aid of the fitted screws. The maximum tightening torque is 0.2 Nm.

2. Input module type CP-E16-KL-IP20-Z

Instructions on wiring the connector sockets from connector set type SEA-KL-SAC10/30

Solid wires and wires with core end sleeves can easily be inserted into the desired tension spring terminal. In order to insert flexible wires, you must use a tool (e.g. a screwdriver) to press down the coloured push button assigned to the tension spring terminal.

1 Tension spring socket from connector set type SEA-KL-SAC10/30

2 Cables

3 Screwdriver

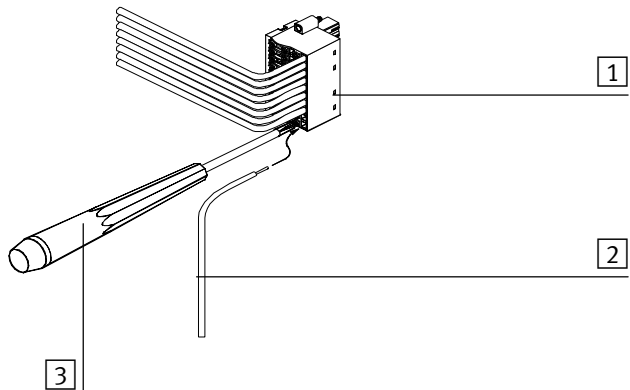
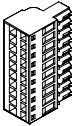
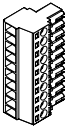

Fig. 2/7: Wiring the connector sockets

2. Input module type CP-E16-KL-IP20-Z



The following connector sets contain further possible connector sockets.

Further possible connector sets	Number	Connector cross section	Possible for connection
Type PSI ZC13-Z (tension spring sockets, 1-row) 	4	See leaflet with product	X1, X2, X3
Type PSI ZC13-S (screw-terminal sockets, 1-row) 	4	See leaflet with product	X1, X2, X3

2. Input module type CP-E16-KL-IP20-Z

2.3.4 Pin assignment (PNP and NPN inputs)

8 sensors can be connected to each of the connections X2 and X3. The voltage supplied externally via pins 1/2 and 9/10 of plug X1 is provided at terminals + and – of X2 and X3 for supplying the sensors.



Caution

Do not connect **any** external supply to terminals + and – of X2 and X3. Otherwise the input module may be damaged.

Pin assignment

- 1** Plug X2
+: 24 V DC
0: I0
1: I1
2: I2
3: I3
4: I4
5: I5
6: I6
7: I7
-: 0 V DC
- 2** Plug X3
+: 24 V DC
0: I8
1: I9
2: I10
3: I11
4: I12
5: I13
6: I14
7: I15
-: 0 V DC

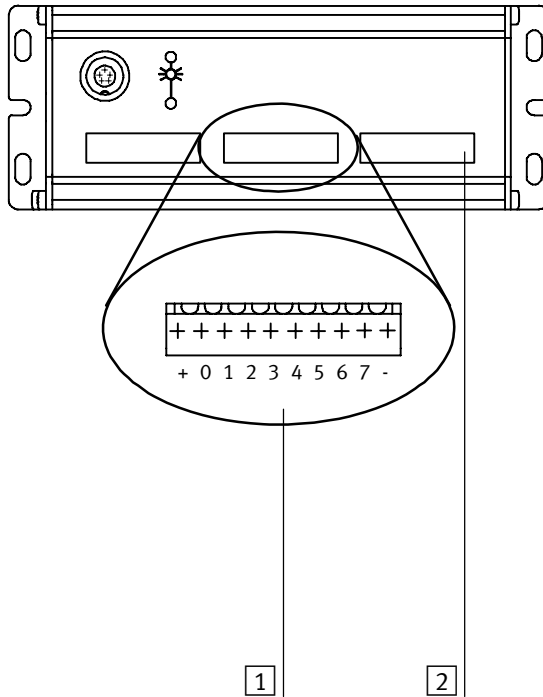

Fig. 2/8: Pin assignment of plugs X2 and X3

2. Input module type CP-E16-KL-IP20-Z

2.3.5 Circuitry examples of PNP inputs

Three-row connector socket from connector set type SEA-KL-SAC10/30

Two rows of the three-row connector socket are intended as distributor boards for the sensor supply. These rows are each connected internally. The upper row (blue push buttons) is intended for the 0 V distributor, the centre row (red push buttons) is intended for the 24 V distributor. The relevant voltage must be supplied with the aid of an external bridge from terminals + and – (lower row).

1 External bridge for potential distribution (24 V)

2 External bridge for potential distribution (0 V)

3 Pin assignment
+: 24 V
0...7: $I_x + n$
-: 0 V

4 Contact

5 Two-wire sensor (positive-switching)

6 Three-wire sensor (positive-switching)

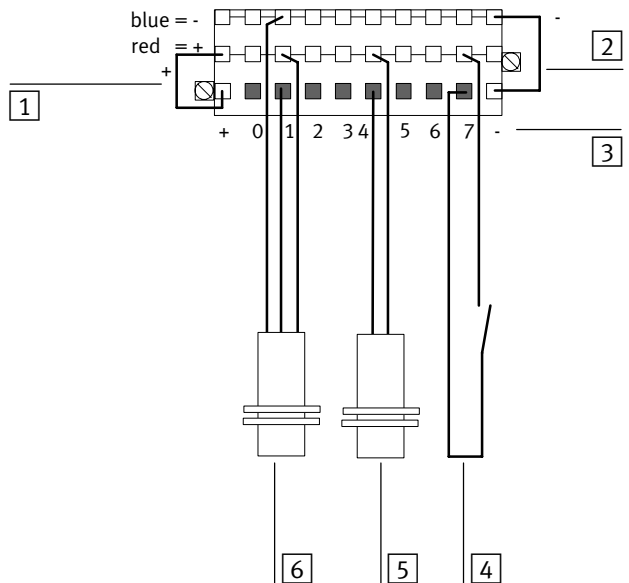

I_x = Input x

Fig. 2/9: PNP inputs (3-row connector socket set SEA-KL-SAC10/30)

2. Input module type CP-E16-KL-IP20-Z

Single-row connector socket

1 External potential distribution (24 V)

2 Pin assignment
+: 24 V
0...7: $I_x + n$
-: 0 V

3 External potential distribution (0 V)

4 Contact

5 Two-wire sensor (positive-switching)

6 Three-wire sensor (positive-switching)

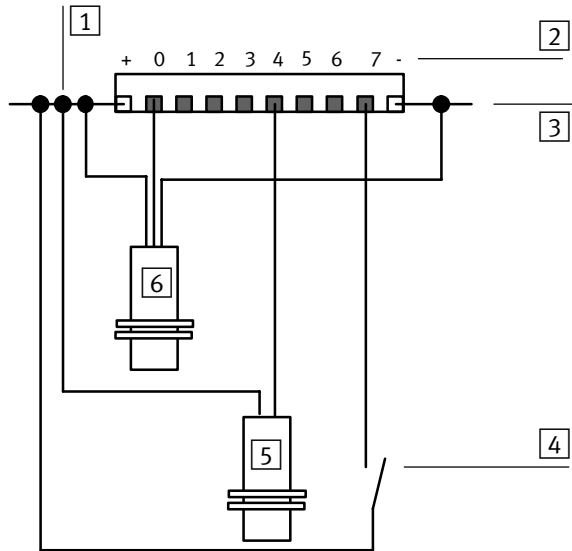

I_x = Input x

Fig. 2/10: PNP inputs (1 row, connector socket)

2. Input module type CP-E16-KL-IP20-Z

Internal structure (PNP operation)

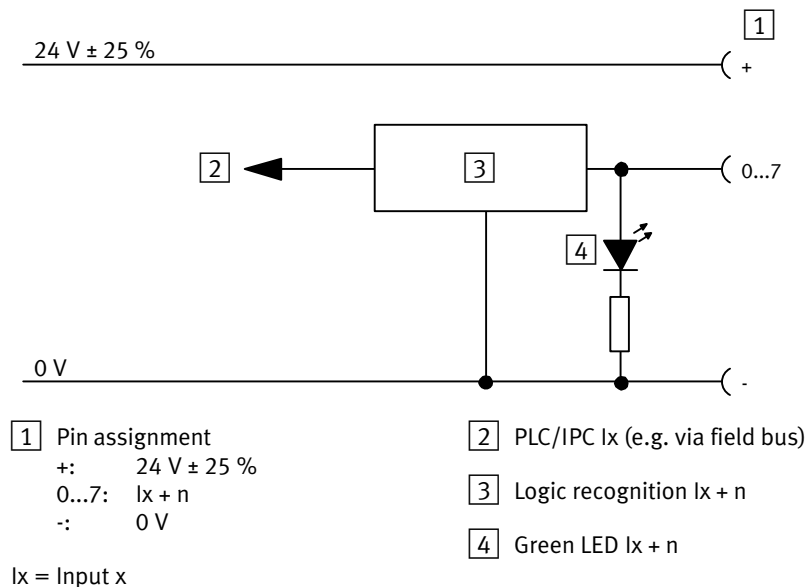

Fig. 2/11: Internal structure (PNP operation)

2. Input module type CP-E16-KL-IP20-Z

2.3.6 Circuitry examples of NPN inputs

Three-row connector socket from connector set type SEA-KL-SAC10/30

Two rows of the three-row connector socket are intended as distributor boards for the sensor supply. These rows are each connected internally. The upper row (blue push buttons) is intended for the 0 V distributor, the centre row (red push buttons) is intended for the 24 V distributor. The relevant voltage must be supplied with the aid of an external bridge from terminals + and – (lower row).

1 External bridge for potential distribution (24 V)

2 External bridge for potential distribution (0 V)

3 Pin assignment
+: 24 V
0...7: I_x + n
-: 0 V

4 Contact

5 Two-wire sensor (negative-switching)

6 Three-wire sensor (negative-switching)

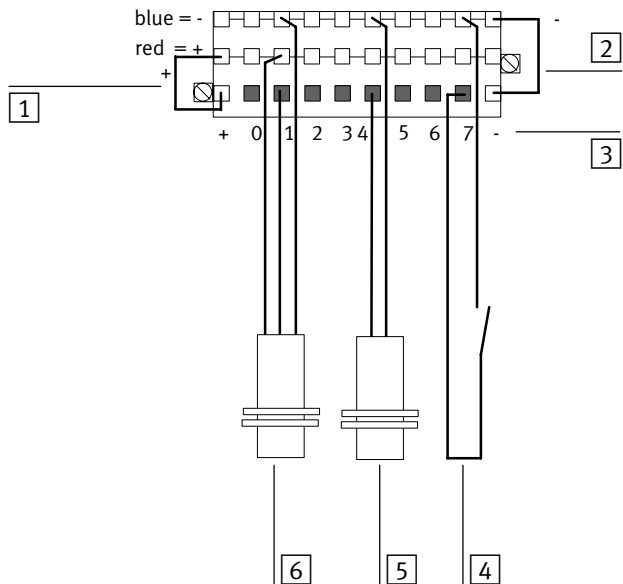

I_x = Input x

Fig. 2/12: NPN inputs (3-row connector socket set SEA-KL-SAC10/30)

2. Input module type CP-E16-KL-IP20-Z

- 1 Pin assignment
+: 24 V
0...7: Ix + n
-: 0 V
- 2 External potential distribution (0 V)
- 3 Three-wire sensor (negative-switching)
- 4 Two-wire sensor (negative-switching)
- 5 Contact
- 6 External potential distribution (24 V)

Ix = Input x

Single-row connector socket

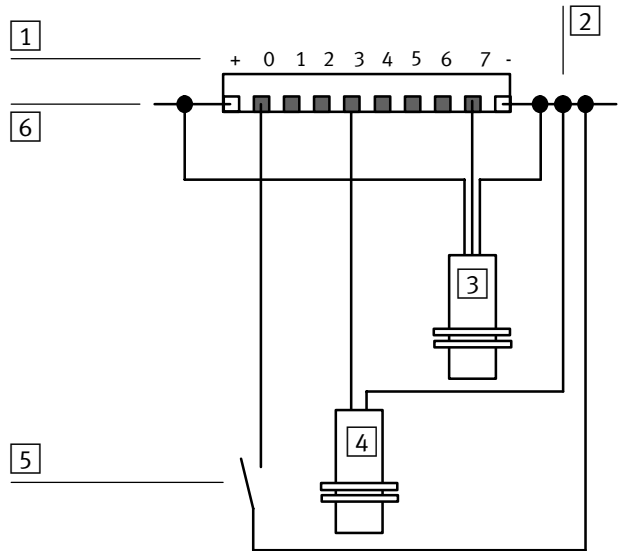
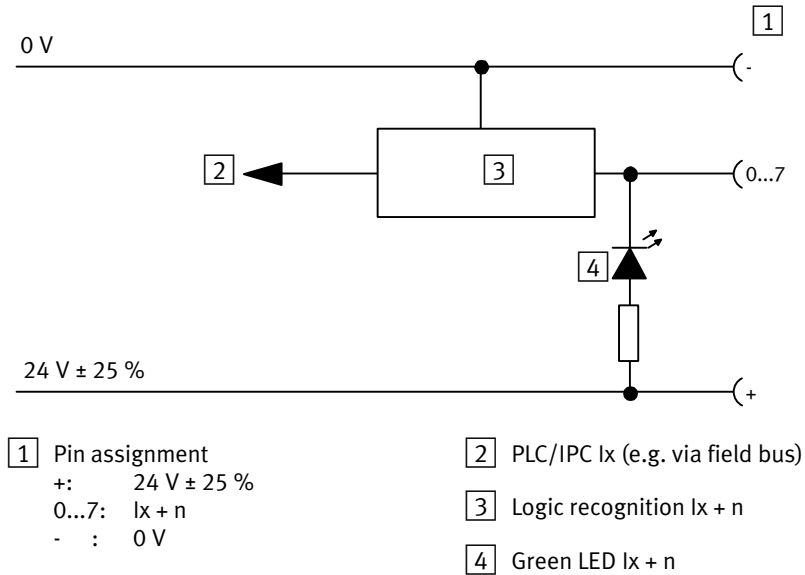

Fig. 2/13: NPN inputs (1 row, connector socket)

2. Input module type CP-E16-KL-IP20-Z

Internal structure (PNP operation)



Ix = Input x

Fig. 2/14: Internal structure (NPN operation)

2. Input module type CP-E16-KL-IP20-Z

2.3.7 Connecting the input module



Caution

Please observe the maximum permitted string lengths. You can thereby avoid errors in data exchange between the input module and the higher-order system (e.g. field bus node).

Use only the following original cables for connecting the modules:

For connection to:	Max. permitted string length	Cable type
Field bus node with CP connection or CPV valve terminal with direct connection	10 m	– KVI-CP-1-... or – KVI-CP-2-... (suitable for drag chain)
Axis interface type SPC-AIF-...	See manual for the SPC200 type P.BE-SPC200-...	
Powerbox type CP-FB-TBOX-...	See manual for the higher-order system	

The following functions are provided for the module via the CP cable:

- Operating voltage for the internal electronics
- Connection for data exchange

2. Input module type CP-E16-KL-IP20-Z

Input modules should be connected to one of the following:

- to the CP connection of the higher-order system (field bus node or axis interface or Powerbox)
- to the CP connection of a CP output module
- to the CP connection of a valve terminal.

Further information can be found in the relevant system manual.

2.4 Instructions on commissioning



Warning

Please be careful if the string assignment is modified at a later stage. After saving the string assignment/hardware configuration, check the address assignments of your higher-order system before starting user programs.

You can thereby avoid:

- addressing errors with unintentionally incorrectly fitted CP modules.

If, in the case of CP field bus nodes and CP valve terminals with direct connection, the string assignment is modified (CP modules added or removed), the new string assignment must be saved or configured.

Depending on the design of the node or CP valve terminal, this is accomplished as follows:

- press the SAVE button or
- configure with the DIL switch.





Proceed here as described in the manual “CP system, installation and commissioning” or in the manual for your “CP valve terminal with direct connection”.

When the string assignment has been modified on the SPC200, the new hardware configuration must also be saved. Proceed here as described in the manual for the SPC200 or in the WinPISA manual.

Status LED

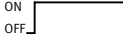
The operating status of the input module is indicated by the status LED on the CP connection (see table below).

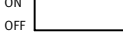
2. Input module type CP-E16-KL-IP20-Z

Status LED	Sequence	Operating status	Error treatment
 LED lights up		Operating voltage applied	None
 LED is out		<ul style="list-style-type: none"> – Operating voltage not applied or no connection to the higher-order system or In conjunction with the CP node: <ul style="list-style-type: none"> – Incorrect string assignment ascertained during operation In conjunction with the SPC200: <ul style="list-style-type: none"> – See user manual for the SPC200 	<ul style="list-style-type: none"> • Check the CP cable and the operating voltage connection on the higher-order system or <ul style="list-style-type: none"> • Correct string assignment <ul style="list-style-type: none"> • See user manual type P.BE-SPC200
 LED flashes		<ul style="list-style-type: none"> – Test phase when power supply has been switched on or – Short circuit in sensor supply ²⁾ or – Undervoltage in sensor supply (< 17 V) or In conjunction with the CP node: <ul style="list-style-type: none"> – Incorrect string assignment when operating voltage is switched on In conjunction with the SPC200: <ul style="list-style-type: none"> – See user manual for the SPC200 	<ul style="list-style-type: none"> • None or <ul style="list-style-type: none"> • Eliminate short circuit or • Eliminate undervoltage <ul style="list-style-type: none"> • Check string assignment ¹⁾ <ul style="list-style-type: none"> • See user manual type P.BE-SPC200
<p>¹⁾ When the string assignment has been modified (CP modules added or removed), the new string assignment must be saved or configured (see manual “CP system, installation and commissioning” or “CP valve terminal with direct connection”).</p> <p>²⁾ The short circuit LED of the relevant input module lights up.</p>			

2. Input module type CP-E16-KL-IP20-Z

Short circuit in sensor supply

If there is a short circuit, the input module will switch off the power supply for the relevant input module and pass the error on to the higher-order system. The short circuit LED of the relevant input module lights up.

- 1 Red LED for short circuit/overload display (one LED per input module)
- 2 Input module (plug X3)
- 3 Input module 1 (plug X2)

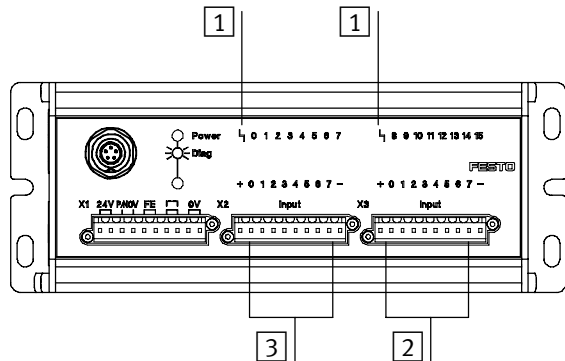

Fig. 2/15: Short circuit displays

Reaction with PNP operation (positive logic)

All status LEDs of the relevant input module are switched off. The status LEDs of the non-affected input module continue to show the status. However, the inputs are no longer processed in respect of software. For all 16 inputs, the module supplies a 0-signal to the higher-order system. When the short circuit is eliminated, the error will be deleted automatically.

Reaction with NPN operation (negative logic)

All status LEDs of the relevant input module are switched on. The status LEDs of the non-affected input module continue to show the status. However, the inputs are no longer processed in respect of software. For all 16 inputs, the module supplies a 0-signal to the higher-order system. When the short circuit is eliminated, the error will be deleted automatically.

2. Input module type CP-E16-KL-IP20-Z

Replacing CP modules

If a fault occurs on a CP module during operation, you can replace the module during operation by another module of the same type.







Please note

Please note here the instructions in the manual for the higher-order system (e.g. CP system, CP field bus node, SPC200).

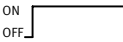
Status display

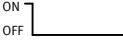
There are green LEDs above the sensor connections. These indicate the status of the signal at the relevant input. The LEDs indicate the following:

Status LED	Sequence	Status
 LED lights up	ON  OFF 	Logical 1 (signal present)
 LED is out	ON  OFF 	Logical 0 (no signal)

2. Input module type CP-E16-KL-IP20-Z

2.5 Technical specifications

Technical specifications	Type CP-E16-...-...
Temperature range: – Operation – Storage/transport	- 5 °C ... + 50 °C - 20 °C ... + 70 °C
Relative humidity	95 % non-condensing
Protection against electric shock as per EN 60204-1 / IEC 204	(Protection against direct and indirect contact) by connection to a PELV power unit (Protected Extra Low Voltage)
Electromagnetic compatibility – Interference emitted – Immunity against interference	Tested as per EN 55011, limit class B Tested as per EN 61000-6-2 ¹⁾
Vibration and shock – Vibration – Shock	Tested as per DIN/IEC 68/EN 60068 part 2-6; Severity class 2 Tested as per DIN/IEC 68/EN 60068 part 2-27; Severity class 2
1) The maximum permitted signal cable length is 30 m.	

2. Input module type CP-E16-KL-IP20-Z

Special technical data	Type CP-E16-KL-IP20-Z; positive switching (PNP) – or negative switching (NPN) operation
Protection class as per DIN 60529	IP20
Digital inputs – Design	16 inputs as per IEC 1131-2 type 2 inputs 24 V DC, positive or negative switching
– Logical level, positive switching ON OFF – Logical level, negative switching ON OFF	PNP (reference 0 V): ≥ 8.6 V ≤ 6 V NPN (reference 24 V): ≤ 6 V ≥ 8.6 V
– Current consumption (at 24 V) (input current from sensor to input)	at “logical 1” typ. 8 mA
– Response delay (at 24 V)	typ. 3 ms
Sensor supply V_D 24 V ± 25 %	Max. 1 A per input group (electronic short-circuit protection per group)
Electrical isolation of the power supply for the sensors/inputs from the power supply for the electronics and the CP bus	Yes
Internal current consumption of electronics	< 40 mA

Output modules type CP-A08...-M12-...

Chapter 3

Contents

3.	Output modules type CP-A08...-M12-....	3-1
3.1	Summary	3-3
3.2	Fitting	3-4
3.3	Installation	3-5
3.3.1	Connecting the actuators	3-6
3.3.2	Connecting the output module	3-13
3.3.3	Connecting the load voltage	3-14
3.4	Instructions on commissioning	3-17
3.5	Technical specifications	3-20

3. Output modules type CP-A08...-M12-...

3.1 Summary

Output module CP-A08...-M12-... provides 8 universally usable digital outputs for controlling low-current consuming devices (bulbs, further valves etc.). The diagram below shows the display and connecting elements on the output module.

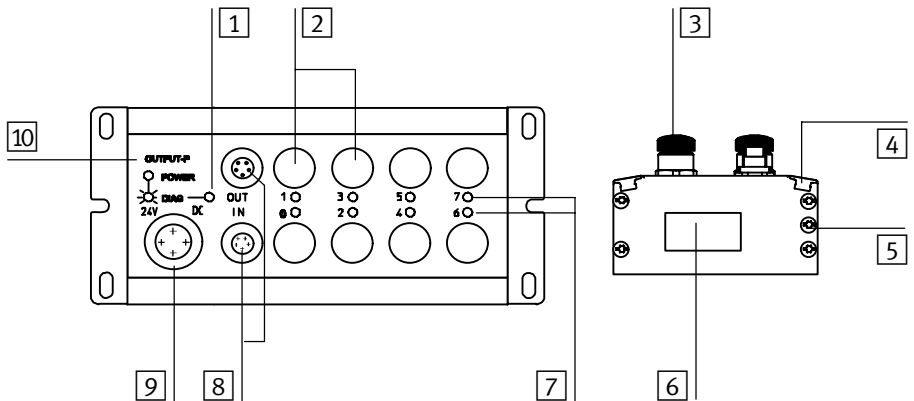

- | | | | |
|---|--|----|--|
| 1 | Status LED (green) | 6 | Type plate |
| 2 | Connections for actuators | 7 | Yellow LED for status display (one LED per output) |
| 3 | Protective cap | 8 | CP connection |
| 4 | Groove for identification signs (IBS 6x10) | 9 | Load voltage connection |
| 5 | Earth/ground connection | 10 | Identifier for output type
OUTPUT-P for PNP outputs
OUTPUT-N for NPN outputs |

Fig. 3/1: Display and connecting elements

3. Output modules type CP-A08...-M12-...

3.2 Fitting

The output module is intended for fitting onto a wall and a hat rail. It requires a mounting area of approx. 173 x 78 mm.

Fitting onto a wall

The diagram below shows the dimensions for the four threaded holes of M4 screw size.

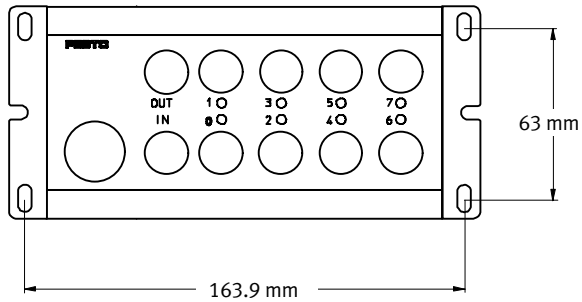

Fig. 3/2: Fitting dimensions for output module CP-A08...-M12-...

Fitting onto a hat rail

The procedure for fitting onto a hat rail is the same as with the input modules type CP-E16...-M... (see section 1.2).

3.3 Installation



Warning

Before carrying out installation and maintenance work, switch off the following:

- the load voltage on the relevant output module.

Also switch off the following when carrying out installation work:

- the operating voltage supply for the higher-order system
- the load voltage supply for all the output modules

You can thereby avoid:

- unexpected movements of the connected actuators
- non-defined switching states of the electronic components.



Warning

Connect the earth connection on the side of the housing (see fig. 2/1) with low impedance (short cable with large cross-sectional area) to the earth potential.

In this way you can avoid faults due to electromagnetic influences and ensure electromagnetic compatibility in accordance with EMC guidelines.

3. Output modules type CP-A08...-M12-...

3.3.1 Connecting the actuators

Use plugs with union nuts with M12 thread for connecting the actuators. Fasten the plugs with the aid of the union nut in order to prevent unintentional loosening, e.g. due to shock.

Seal the unused connections with the protective caps supplied. Only in this way can you comply with protection class IP65.

Pin assignment of the actuator connections on the CP-A08-M12-... (PNP outputs)

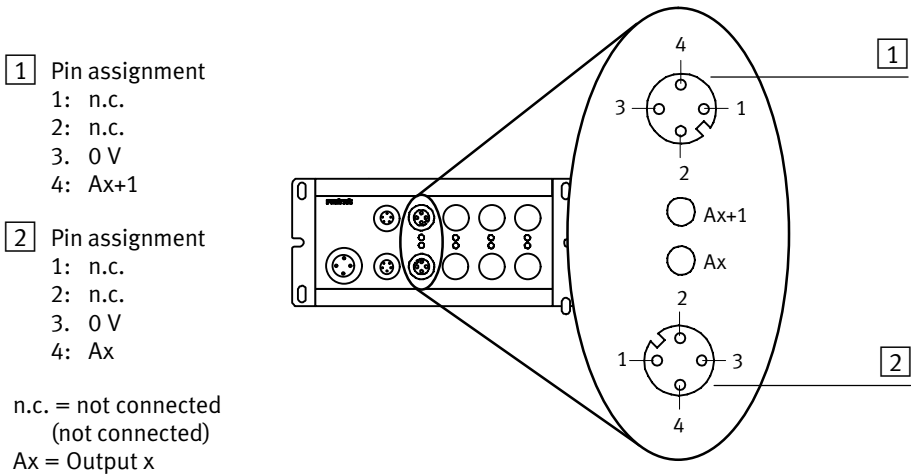

Fig. 3/3: Pin assignment of output module CP-A08...-M12-...

3. Output modules type CP-A08...-M12-...

By means of internal connections, two outputs can be connected on each of the output sockets 0, 2, 4 and 6 on the CP output module type CP-A08-M12-5POL.

- 1** Pin assignment
 1: n.c.
 2: n.c.
 3: 0 V
 4: Ax+1
 5: earth/ground connection
- 2** Internal connection in the module
- 3** Pin assignment
 1: n.c.
 2: Ax+1
 3: 0 V
 4: Ax
 5: earth/ground connection

n.c. = not connected
 (not connected)
 Ax = Output x

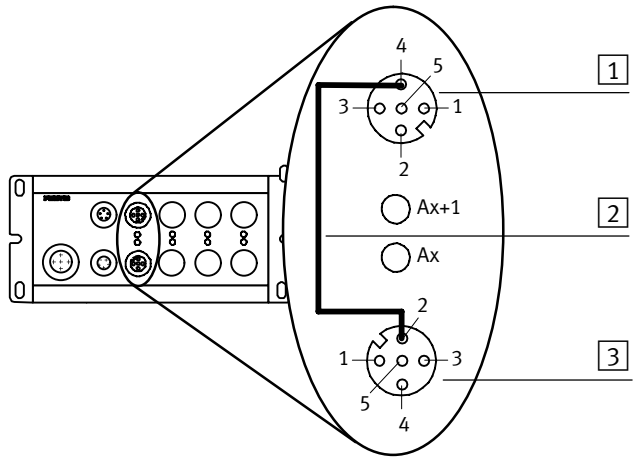
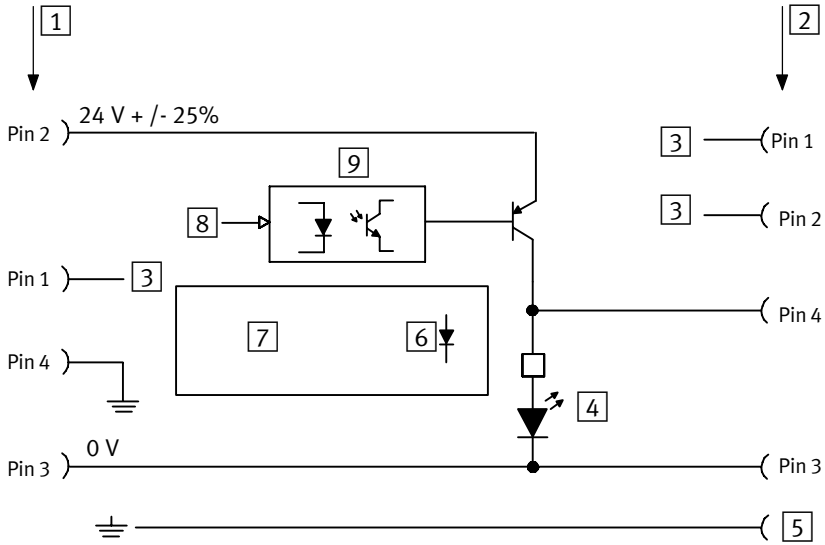

Fig. 3/4: Pin assignment of output module CP-A08-M12-5POL

3. Output modules type CP-A08...-M12-...

Internal structure of CP-A08...-M12... (PNP outputs)



- | | |
|---|--|
| <p>1 Load voltage connection</p> <p>2 Actuator connection</p> <p>3 On type CP-A08...-M12-...
n.c. = not connected on type CP-A08-M12-5POL
– connections 0, 2, 4, 6: Ax+1
– connections 1, 3, 5, 7:
n.c. = not connected</p> <p>4 Yellow LED</p> | <p>5 Pin 5 on type CP-A08-M12-5POL
earth/ground connection</p> <p>6 Green LED</p> <p>7 Diagnosis
– short circuit/overload
– load voltage failure</p> <p>8 PLC/IPC Ax (e.g. via field bus)</p> <p>9 Electrical isolation</p> |
|---|--|

Fig. 3/5: Internal structure of output module CP-A08...-M12-...

3. Output modules type CP-A08...-M12-...

Internal structure of CP-A08...-M12-... (PNP outputs)

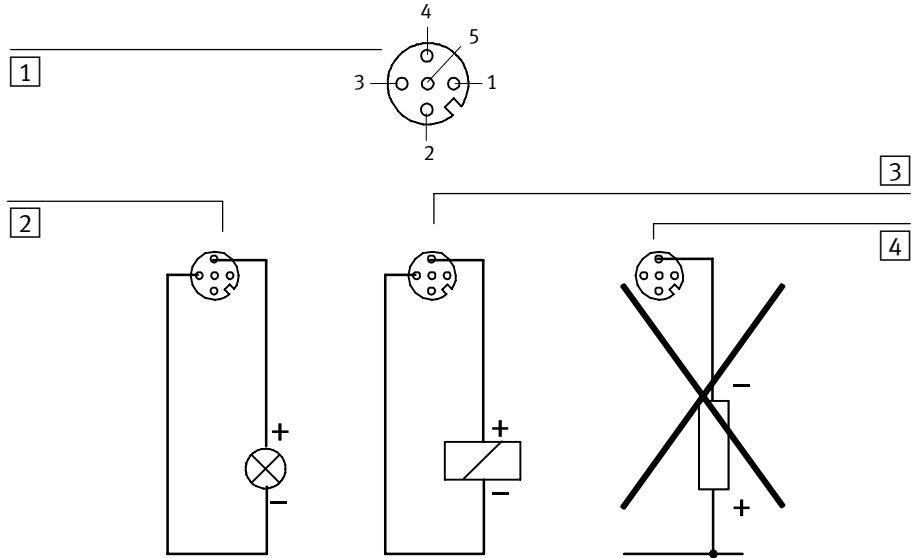

1 Pin assignment

- 1: n.c.
- 2: *)
- 3: 0 V
- 4: Ax+1
- 5: only with type CP-A08-M12-5POL earth/ground connection

*) On type CP-A08...-M12-...

- n.c. = not connected on type CP-A08-M12-5POL
- connections 0, 2, 4, 6: Ax+1
- connections 1, 3, 5, 7: n.c. = not connected

2 Example 1:

3 Example 2:

4 Not permitted

Ax = Output x
n.c. = not connected

Fig. 3/6: Examples of circuitry for output module CP-A08...-M12-...

3. Output modules type CP-A08...-M12-...

Pin assignment of the actuator connections on the CP-A08N-M12-... (NPN outputs)

- 1** Pin assignment
1: 24 V¹⁾
2: earth/ground connection
3: n.c.
4: Ax+1

- 2** Pin assignment
1: 24 V¹⁾
2: earth/ground connection
3: n.c.
4: Ax

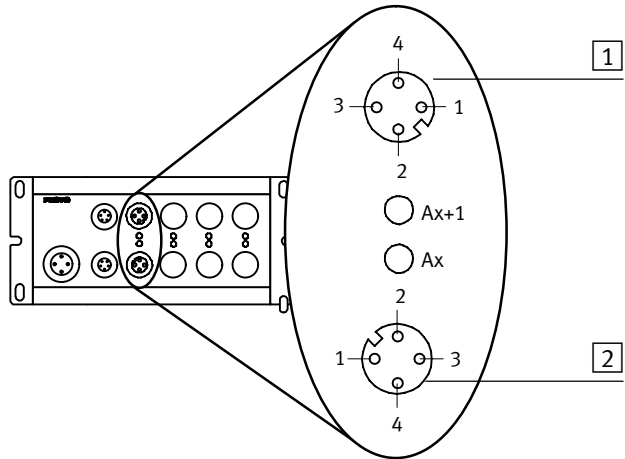

- 1) Current consumer/load must be supplied via this 24 V connection
n.c. = not connected
Ax = output x

Fig. 3/7: Pin assignment of output module CP-A08N-M12-...

3. Output modules type CP-A08...-M12-...

Internal structure of CP-A08N-M12 (NPN outputs)

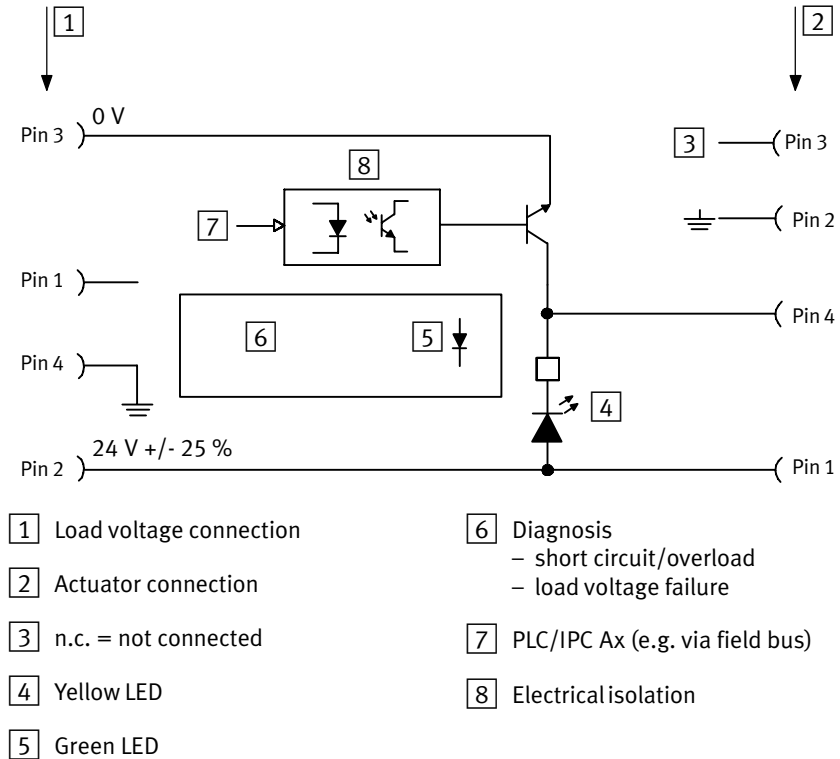
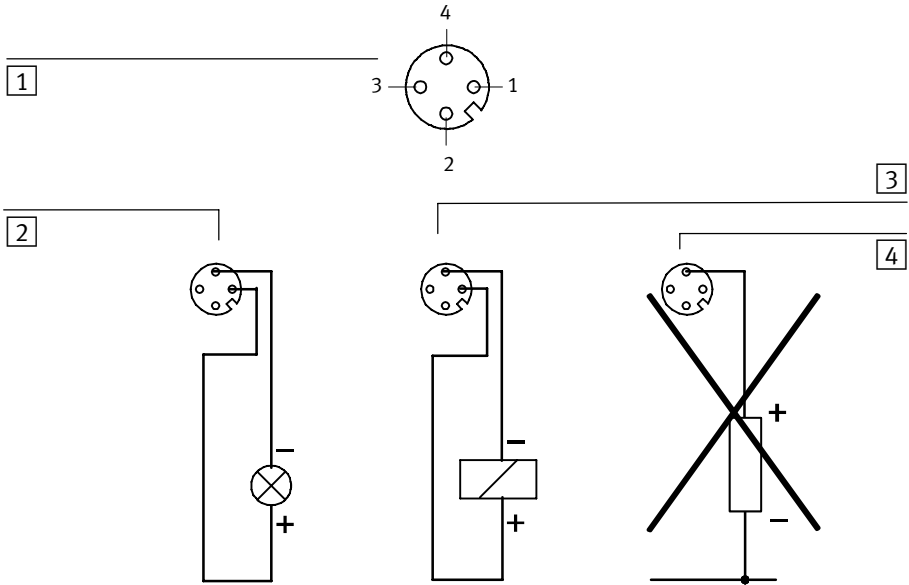

Fig. 3/8: Internal structure of output module CP-A08N-M12

3. Output modules type CP-A08...-M12-...

Circuitry example of CP-A08N-M12 (NPN outputs)



1 Pin assignment

- 1: 24 V¹⁾
- 2: earth/ground connection
- 3: n.c.
- 4: Ax+1

2 Example 1:

3 Example 2:

4 not permitted

¹⁾ Current consumer/load must be supplied via this 24 V connection

n.c. = not connected
Ax = Output x

Fig. 3/9: Examples of circuitry of output module CP-A08N-M12

3. Output modules type CP-A08...-M12-...

3.3.2 Connecting the output module



Warning

Please observe the maximum string lengths. You can thereby avoid errors in data exchange between the output module and the higher-order system (e.g. field bus nodes). Use only the following original cables for connecting the modules:

For connection to:	max. permitted string length	Cable type
Field bus node with CP connection	10 m	– KVI-CP-1-... or – KVI-CP-2-... (suitable for drag chain)
Axis interface type SPC-AIF-...	See manual for the SPC200 type P.BE-SPC200-...	
Powerbox type CP-FB-TBOX-...	See manual for the higher-order system	

Communication and the necessary operating voltage for the internal electronics of the module are carried out via the CP cable.

The output module is connected directly to the CP connection of the higher-order system (field bus node, axis interface or Powerbox). Detailed information can be found in the relevant system manual.

3. Output modules type CP-A08...-M12-...

3.3.3 Connecting the load voltage



Warning

Use only power units which guarantee reliable isolation of the operating voltages as per IEC 742/EN 60742/VDE 0551 with at least 4 kV isolation resistance (Protected Extra Low Voltage PELV).

Switch power packs are permitted, providing they guarantee reliable isolation in accordance with EN 60950 / VDE 0805.



By the use of PELV power units, protection against electric shock (protection against direct and indirect contact) is guaranteed with the SPC10 in accordance with EN 60204-1/IEC 204. Safety transformers with the adjacent symbol must be used for supplying PELV networks. The CP output module must be earthed to ensure that it functions correctly (e.g. EMC).

The connected actuators are supplied with + 24 V DC via the load voltage connection on the output module. Use a cable for the operating voltage with sufficient cross-sectional area.

3. Output modules type CP-A08...-M12...

The diagram below shows the pin assignment of the load voltage connection on the output module with an example.

- 1** Pin assignment
 1: n.c.
 2: 24 V DC
 $\pm 25\%$
 3: 0 V
 4: earth/ground connection

- 2** The load voltage can be switched off separately; the operating voltage is supplied via the CP connection.

n.c. = not connected (not connected)

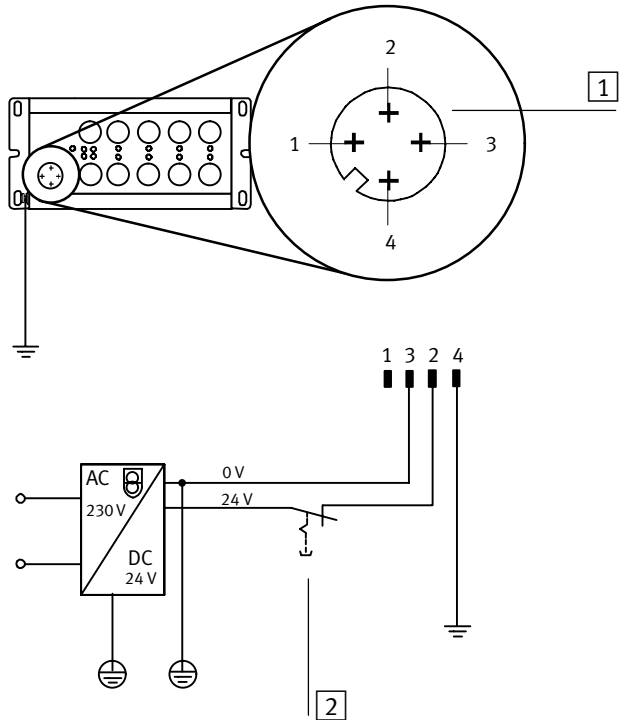

Fig. 3/10: Pin assignment and example of the load voltage connection

3. Output modules type CP-A08...-M12-...

Potential equalization

The CP module has two earthing connections for potential equalization:

- at the load voltage connection (pin 4)
- on the housing (earthing connection see Fig. 3/10).



Please note

- Always connect the earth potential to pin 4 of the load voltage connection.
- Connect the earth connection on the left-hand side of the housing with low impedance (short cable with large cross-sectional area) to the earth potential.
- With low-impedance connections you can ensure that the housing of the output module and the earth connection at pin 4 have the same potential and that there are no equalizing currents.

In this way you can avoid faults due to electromagnetic influences and ensure electromagnetic compatibility in accordance with EMC guidelines.



Please note

Check within the framework of your EMERGENCY STOP circuit, to ascertain the measures necessary for putting your machine/system into a safe state in the event of an EMERGENCY STOP (e.g. switching of the operating voltage for the valves and output modules, switching off the compressed air).

3. Output modules type CP-A08...-M12-...

3.4 Instructions on commissioning



Warning

Please be careful if the string assignment is modified at a later stage.

After saving the string assignment/hardware configuration, check the address assignments of your higher-order system before starting user programs.

You can thereby avoid:

- addressing errors with unintentionally incorrectly fitted CP modules.







When the string assignment on CP field bus nodes has been modified (CP modules added or removed), you must save the new string assignment by pressing the SAVE button on the node. Proceed here as described in the manual “CP system, installation and commissioning”.

When the string assignment has been modified on the SPC200, the new hardware configuration must also be saved. Proceed here as described in the manual for the SPC200 or in the WinPISA manual.

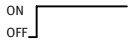
Status LED

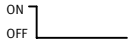
The operating status of the output module is indicated by the status LED on the CP connection (see table below).

3. Output modules type CP-A08...-M12-...

Status LED	Sequence	Operating status	Error treatment
 LED lights up		Operating voltage applied	None
 LED is out		<ul style="list-style-type: none"> - Operating voltage not applied or no connection to node or In conjunction with the CP node: <ul style="list-style-type: none"> - incorrect string assignment ascertained during operation In conjunction with the SPC200: <ul style="list-style-type: none"> - see user manual for the SPC200 	<ul style="list-style-type: none"> • Check CP cable and operating voltage connection on node (pin 1) or • correct string assignment • see user manual for the SPC200
 LED flashes fast		<ul style="list-style-type: none"> - Test phase when power supply has been switched on or - short circuit/overload on at least one output module or In conjunction with the CP node: <ul style="list-style-type: none"> - incorrect string assignment when operating voltage is switched on In conjunction with the SPC200: <ul style="list-style-type: none"> - see user manual for the SPC200 	<ul style="list-style-type: none"> • None or • eliminate short circuit/overload and reset output ¹⁾ or • check string assignment ²⁾ • see user manual for the SPC200
 LED flashes slowly		Load voltage failure	Restore load voltage
<p>¹⁾ In the event of a short circuit/overload all the outputs on the module will be switched off automatically. The fault must be eliminated when the outputs are reset. (e.g. by user program).</p> <p>²⁾ When the string assignment has been modified (CP modules added or removed), you must save the new string assignment by pressing the SAVE button on the node.</p>			

3. Output modules type CP-A08...-M12...

Short circuit/overload

In the event of a short circuit/overload, the output module will switch off all 8 outputs self-holding and pass the error on to the CP node or the SPC200. When the short circuit has been eliminated, delete this error as follows:

- Reset all 8 outputs (e.g. by user program)

Replacing CP modules

If a fault occurs on a CP module during operation, you can replace the module during operation by another module of the same type.







Please note

Please note here the instructions in the manual for the higher-order system (e.g. CP system, CP field bus node, SPC200).

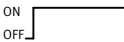
Status display

There are two yellow LEDs next to the connections for the actuators. These indicate the status of the signal at the relevant output. The meanings are as follows:

Status LED	Sequence	Status
 LED lights up	ON  OFF 	Output supplies a 1-signal
 LED is out	ON  OFF 	Output supplies a 0-signal

3. Output modules type CP-A08...-M12-...

3.5 Technical specifications

General technical specifications	Type CP-A...-M12 and CP-A...-M12-...
Temperature range: <ul style="list-style-type: none"> - Operation - Storage/transport 	- 5 °C ... + 50 °C - 20 °C ... + 70 °C
Relative humidity	95 % non-condensing
Protection class as per EN 60529; plug connector inserted or provided with protective cap	IP65
Protection against electric shock as per EN 60204-1 / IEC 204	By connection to a PELV power unit (Protected Extra Low Voltage)
Electromagnetic compatibility <ul style="list-style-type: none"> - Interference emitted - Immunity against interference 	Tested as per EN 55011, limit class B Tested as per EN 50082-2
Vibration and shock <ul style="list-style-type: none"> - Vibration - Shock 	Tested as per DIN/IEC 68/EN 60068 part 2-6; severity class 2 Tested as per DIN/IEC 68/EN 60068 part 2-27; severity class 2
Load voltage connection <ul style="list-style-type: none"> - Rated value (protected against incorrect polarity) - Tolerance - Residual ripple - Insulation resistance - Internal current consumption of electronics 	Electrically isolated load voltage supply via additional M18 plug connector 24 V ± 25 % 4 V _{pp} (within tolerance) 500 V < 40 mA

3. Output modules type CP-A08...-M12-...

Special technical data (PNP outputs)	Positive-switching output module
	Type CP-A08-M12 and type CP-A08-M12-5POL
Digital outputs – Design	8 outputs as per IEC 1131-2; 24 V DC, positive-switching 0.5 A
– Maximum load per digital output	
– Electronic fuse (short circuit, overload) Trigger current Response time	Min. 750 mA Max. 1.5 ms

Special technical data (NPN outputs)	Negative-switching output modules
	Type CP-A08N-M12
Digital outputs – Design	8 outputs as per IEC 1131-2; 24 V DC, negative-switching 0.5 A
– Maximum load per digital output	
– Electronic fuse (short circuit, overload) Trigger current Response time	Typical 1 A Max. 1.5 ms

3. Output modules type CP-A08...-M12-...

Index

Appendix A

Contents

A.	Index	A-1
A.1	Index	A-3

A

Accessories

Connector sockets	2-13
Fastening kit	2-6
Original cable	2-23
Actuators, Connecting	3-6

C

Connect the output module, To the node	1-26
Connector socket set, Type SEA-KL-SAC10/30	2-13
Connector sockets	2-13

D

Designated use	V
----------------------	---

E

Earth/ground, Potential equalization	2-12
Earthing, Potential equalization	1-14, 3-16

F

Fitting

Fitting onto a hat rail	2-6
Fitting onto a wall	2-5
Input module	1-6, 2-5
Output module	3-4

I

Important user instructions	VII
Input module	
Circuitry example CP-E16-M8 (NPN)	2-20

Circuitry example of CP-E16...-M8-... (NPN)	1-23
Circuitry example of CP-E16-M8	1-19
Circuitry example of CP-E16-M8 (NPN)	2-17
Circuitry examples of CP-E16-M12x2-...	1-21
Circuitry examples of CP-E16N-M12x2	1-25
Connect to the node	2-23
Fitting onto a hat rail	1-8
Fitting onto a wall	1-6
Internal structure CP-E16-KL-IP20-Z (NPN)	2-22
Internal structure CP-E16-KL-IP20-Z (PNP)	2-19
Internal structure of CP-E16...-M8-... (NPN)	1-22
Internal structure of CP-E16-M12x2-...	1-20
Internal structure of CP-E16N-M12x2	1-24
Internal structure of type CP-E16-M8-...(PNP)	1-18
Replace during operation	2-28

L

LED

Short circuit display/sensor voltage failure	2-27
Signal status display	2-28
Status LED of input module	1-28 , 2-25 , 3-17

N

Notes on the use of this manual	IX
---------------------------------------	----

O

Output module

Circuitry example of CP-A08N-M12	3-12
Example of circuitry on CP-A08...-M12-...	3-9
Fitting onto a hat rail	3-4
Fitting onto a wall	3-4
Internal structure of CP-A08...-M12-...	3-8
Internal structure of CP-A08N-M12	3-11
Replace during operation	1-31 , 3-19

P

Pictograms	VIII
------------------	------

Pin assignment	
Inputs (PNP/NPN)	1-16
Inputs (X2/X3)	2-16
NPN outputs	3-10
Operation voltage connection on CP-A08...-M12	3-15
PNP outputs	3-6
Sensor supply for CP-E16-KL-IP20-Z	2-11
Sensor supply for CP-E16-M8-Z	1-13
PNP/NPN operation	2-9

S

Sensors

Circuitry example CP-E16-KL-IP20-Z (NPN)	2-20, 2-21
Circuitry example CP-E16-KL-IP20-Z (PNP)	2-17, 2-18
Circuitry example of CP-E16...-M8-... (NPN)	1-23
Circuitry example of CP-E16-M8-... (PNP)	1-19
Circuitry examples of CP-E16-M12x2-...	1-21
Circuitry examples of CP-E16N-M12x2	1-25
Connecting	1-15
Input module, type CP-E16...-M8-...	1-16
Pin assignment of type CP-E16...-M12x2	1-16
Pin assignment of type CP-E16-M12x2-5POL	1-17

Service	VI
---------------	----

Short circuit

Load voltage	3-19
Sensor supply	1-31
Sensor supply for CP-E16-KL-IP20-Z	2-27
Sensor supply for CP-E16-M8-Z	1-30

Status display

Input module	1-32, 2-28
Output module	3-19

Status LED, Input module	1-28, 2-25, 3-17
--------------------------------	------------------

T

Target group	VI
--------------------	----

Technical specifications

Input module CP-E16...-... (general specifications) ..	2-29
--	------

A. Index

Input module CP-E16-KL-IP20-Z (special data)	2-30
Input module CP-E16-M...-... (PNP)	1-35
Input module CP-E16N-M... (NPN)	1-36
Input module for CP-E16...-... (general)	1-33
Output module CP-A08-M12... (general)	3-20
Output module CP-A08N-M12 (NPN)	3-21
Output module CP-A08N-M12 (PNP)	3-21
Sensor supply for CP-E16-M8-Z (PNP)	1-34
Text markings	VIII