

# EPSON®



## SED1375 Embedded Memory LCD Controller

# SED1375 TECHNICAL MANUAL

Document No. X27A-Q-001-01

Copyright © 1999 Epson Research and Development, Inc. All Rights Reserved.

Information in this document is subject to change without notice. You may download and use this document, but only for your own use in evaluating Seiko Epson/EPSON products. You may not modify the document. Epson Research and Development, Inc. disclaims any representation that the contents of this document are accurate or current. The Programs/Technologies described in this document may contain material protected under U.S. and/or International Patent laws.

EPSON is a registered trademark of Seiko Epson Corporation. All other Trademarks are the property of their respective owners

---

**THIS PAGE LEFT BLANK**

# Customer Support Information

## Comprehensive Support Tools

Seiko Epson Corp. provides to the system designer and computer OEM manufacturer a complete set of resources and tools for the development of graphics systems.

## Evaluation / Demonstration Board

- Assembled and fully tested graphics evaluation board with installation guide and schematics.
- To borrow an evaluation board, please contact your local Seiko Epson Corp. sales representative.

## Chip Documentation

- Technical manual includes Data Sheet, Application Notes, and Programmer's Reference.

## Software

- OEM Utilities.
- User Utilities.
- Evaluation Software.
- To obtain these programs, contact Application Engineering Support.

## Application Engineering Support

Engineering and Sales Support is provided by:

### Japan

Seiko Epson Corporation  
Electronic Devices Marketing Division  
421-8, Hino, Hino-shi  
Tokyo 191-8501, Japan  
Tel: 042-587-5812  
Fax: 042-587-5564  
<http://www.epson.co.jp>

### North America

Epson Electronics America, Inc.  
150 River Oaks Parkway  
San Jose, CA 95134, USA  
Tel: (408) 922-0200  
Fax: (408) 922-0238  
<http://www.eea.epson.com>

### Taiwan, R.O.C.

Epson Taiwan Technology  
& Trading Ltd.  
10F, No. 287  
Nanking East Road  
Sec. 3, Taipei, Taiwan, R.O.C.  
Tel: 02-2717-7360  
Fax: 02-2712-9164

### Hong Kong

Epson Hong Kong Ltd.  
20/F., Harbour Centre  
25 Harbour Road  
Wanchai, Hong Kong  
Tel: 2585-4600  
Fax: 2827-4346

### Europe

Epson Europe Electronics GmbH  
Riesstrasse 15  
80992 Munich, Germany  
Tel: 089-14005-0  
Fax: 089-14005-110

### Singapore

Epson Singapore Pte., Ltd.  
No. 1  
Temasek Avenue #36-00  
Millenia Tower  
Singapore, 039192  
Tel: 337-7911  
Fax: 334-2716

**THIS PAGE LEFT BLANK**

---

# Table of Contents

## **INTRODUCTION**

SED1375 Embedded Memory LCD Controller Product Brief

## **SPECIFICATION**

SED1375 Hardware Functional Specification

## **PROGRAMMER'S REFERENCE**

SED1375 Programming Notes and Examples

SED1375 Register Summary

## **UTILITIES**

1375CFG.EXE File Configuration Program

1375SHOW Demonstration Program

1375SPLT Display Utility

1375VIRT Display Utility

1375PLAY Diagnostic Utility

1375BMP Demonstration Program

1375PWR Power Save Utility

## **DRIVERS**

SED1375 Windows® CE Display Drivers

SED13XX 32-Bit Windows Device Driver Installation Guide

## **EVALUATION**

SDU1375B0C Rev. 1 ISA Bus Evaluation Board User Manual

## **APPLICATION NOTES**

Interfacing to the Toshiba MIPS TX3912 Microprocessor

Power Consumption

Interfacing to the Motorola MC68328 Microprocessor

Interfacing to the NEC VR4102/VR4111 Microprocessor

Interfacing to the PC Card Bus

Interfacing to the Motorola MPC821 Microprocessor

Interfacing to the Motorola MCF5307 Microprocessor

Interfacing to the Philips MIPS PR31500/PR31700 Microprocessor

Interfacing to the NEC VR4181 Microprocessor

**THIS PAGE LEFT BLANK**

## SED1375 Embedded Memory LCD Controller

The SED1375 is a color/monochrome LCD graphics controller with an embedded 80K Byte SRAM display buffer. The high integration of the SED1375 provides a low cost, low power, single chip solution to meet the requirements of embedded markets such as Office Automation equipment, Mobile Communications devices, and Palm-size PCs where board size and battery life are major concerns.

Products requiring a "Portrait" display can take advantage of the Hardware Portrait Mode feature of the SED1375. Virtual and Split Screen are just some of the display modes supported. While focusing on devices targeted by the Microsoft Windows CE Operating System, the SED1375's impartiality to CPU type or operating system makes it an ideal display solution for a wide variety of applications.

### ■ FEATURES

- Embedded 80K byte SRAM display buffer.
- Direct support for the following CPU's:
  - Hitachi SH-3.
  - Hitachi SH-4.
  - Motorola M68xxx.
- MPU bus interface with programmable READY.
- Resolutions up to:
  - 640x480 at a color depth of 2 bpp.
  - 640x240 at a color depth of 4 bpp.
  - 320x240 at a color depth of 8 bpp.
- Up to 256 simultaneous colors from a possible 4096 colors on passive LCD panels and active matrix TFT/D-TFD LCD panels.
- Register level support for EL panels.
- Hardware Portrait Mode
- Split Screen Display
- Virtual Display Support
- LCD power-down sequencing.

### ■ SYSTEM BLOCK DIAGRAM

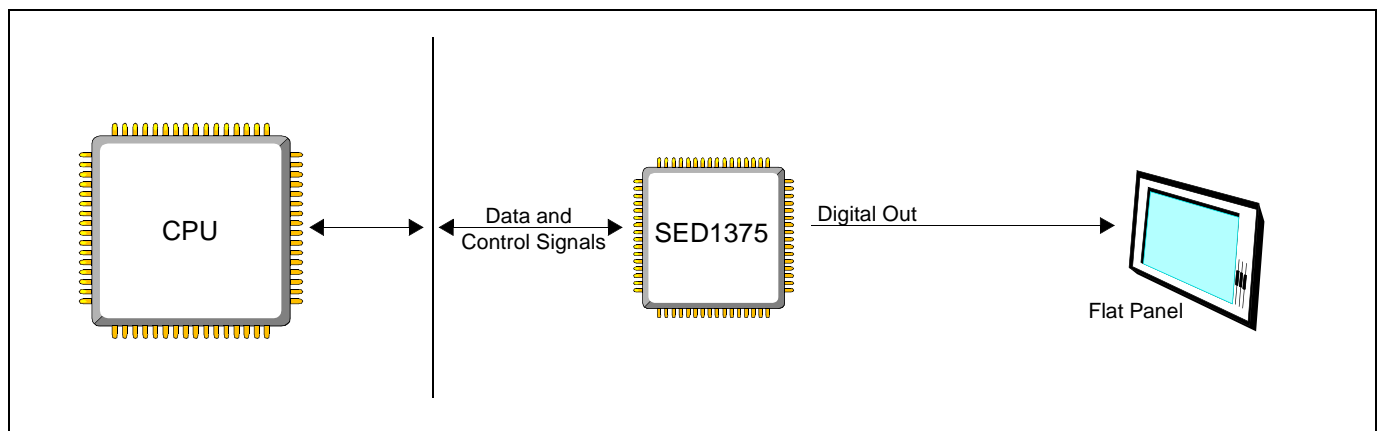

## SED1375

### DESCRIPTION

#### Memory Interface

- Embedded 80K byte SRAM display buffer.

#### CPU Interface

- Direct support for:
  - Hitachi SH-3.
  - Hitachi SH-4.
  - Motorola M68xxx.
- MPU bus interface with programmable READY.
- CPU write buffer.

#### Display Support

- 4/8-bit monochrome LCD interface.
- 4/8-bit color LCD interface.
- Single-panel, single-drive passive displays.
- Dual-panel, dual-drive passive displays.
- Active matrix TFT / D-TFD interface.
- Example resolutions:
  - 640x480 at a color depth of 2 bpp.
  - 640x240 at a color depth of 4 bpp.
  - 320x240 at a color depth of 8 bpp.

#### Clock Source

- Single clock input for both pixel and memory clocks.
- The SED1375 clock source can be internally divided down for a higher frequency clock input.
- Dynamic switching of memory clocks in portrait mode.

#### Display Modes

- 1/2/4/8 bit-per-pixel (bpp) support on LCD.
- Up to 16 shades of gray using FRM on monochrome passive LCD panels.
- Up to 256 simultaneous colors from a possible 4096 colors on passive STN and active matrix TFT/D-TFD LCD panels.
- Split Screen Display: allows two different images to be simultaneously viewed on the same display.
- Virtual Display Support: displays images larger than the display size through the use of panning.
- Double Buffering/multi-pages: provides smooth animation and instantaneous screen update.
- Hardware Portrait Mode: direct hardware 90° rotation of display image for portrait mode display.

#### Power Down Modes

- Software Suspend mode.
- LCD power-down sequencing.

#### Operating Voltage

- CORE<sub>VDD</sub> 2.7 to 3.6 volts; IO<sub>VDD</sub> 2.7 to 5.5 volts.

#### Package

- 80-pin QFP14.

### CONTACT YOUR SALES REPRESENTATIVE FOR THESE COMPREHENSIVE DESIGN TOOLS:

- SED1375 Technical Manual
- SDU1375 Evaluation Boards
- Windows<sup>®</sup> CE Display Driver
- CPU Independent Software Utilities

#### Japan

Seiko Epson Corporation  
Electronic Devices Marketing Division  
421-8, Hino, Hino-shi  
Tokyo 191-8501, Japan  
Tel: 042-587-5812  
Fax: 042-587-5564  
<http://www.epson.co.jp>

#### North America

Epson Electronics America, Inc.  
150 River Oaks Parkway  
San Jose, CA 95134, USA  
Tel: (408) 922-0200  
Fax: (408) 922-0238  
<http://www.eea.epson.com>

### FOR SYSTEM INTEGRATION SERVICES FOR WINDOWS<sup>®</sup> CE CONTACT:

Epson Research & Development, Inc.  
Suite #320 - 11120 Horseshoe Way  
Richmond, B.C., Canada V7A 5H7  
Tel: (604) 275-5151  
Fax: (604) 275-2167  
Email: [wince@erd.epson.com](mailto:wince@erd.epson.com)  
<http://www.erd.epson.com>



#### Taiwan, R.O.C.

Epson Taiwan Technology & Trading Ltd.  
10F, No. 287  
Nanking East Road  
Sec. 3, Taipei, Taiwan, R.O.C.  
Tel: 02-2717-7360  
Fax: 02-2712-9164

#### Hong Kong

Epson Hong Kong Ltd.  
20/F., Harbour Centre  
25 Harbour Road  
Wanchai, Hong Kong  
Tel: 2585-4600  
Fax: 2827-4346

#### Europe

Epson Europe Electronics GmbH  
Riesstrasse 15  
80992 Munich, Germany  
Tel: 089-14005-0  
Fax: 089-14005-110

#### Singapore

Epson Singapore Pte., Ltd.  
No. 1  
Temasek Avenue #36-00  
Millenia Tower  
Singapore, 039192  
Tel: 337-7911  
Fax: 334-2716

Copyright ©1999 Epson Research and Development, Inc. All rights reserved. VDC  
Information in this document is subject to change without notice. You may download and use this document, but only for your own use in evaluating Seiko Epson/EPSON products. You may not modify the document. Epson Research and Development, Inc. disclaims any representation that the contents of this document are accurate or current. The Programs/Technologies described in this document may contain material protected under U.S. and/or International Patent laws. EPSON is a registered trademark of Seiko Epson Corporation. Microsoft, Windows, and the Windows CE Logo are registered trademarks of Microsoft Corporation.



# EPSON®



## SED1375 Embedded Memory LCD Controller

# Hardware Functional Specification

Document Number: X27A-A-001-04

Copyright © 1999 Epson Research and Development, Inc. All Rights Reserved.

Information in this document is subject to change without notice. You may download and use this document, but only for your own use in evaluating Seiko Epson/EPSON products. You may not modify the document. Epson Research and Development, Inc. disclaims any representation that the contents of this document are accurate or current. The Programs/Technologies described in this document may contain material protected under U.S. and/or International Patent laws.

EPSON is a registered trademark of Seiko Epson Corporation. All other Trademarks are the property of their respective owners

---

**THIS PAGE LEFT BLANK**

# Table of Contents

<b>1</b>	<b>Introduction</b>	<b>9</b>
1.1	Scope	9
1.2	Overview Description	9
<b>2</b>	<b>Features</b>	<b>10</b>
2.1	Integrated Frame Buffer	10
2.2	CPU Interface	10
2.3	Display Support	10
2.4	Display Modes	11
2.5	Clock Source	11
2.6	Miscellaneous	11
2.7	Package	11
<b>3</b>	<b>Typical System Implementation Diagrams</b>	<b>12</b>
<b>4</b>	<b>Functional Block Diagram</b>	<b>15</b>
4.1	Functional Block Descriptions	15
4.1.1	Host Interface	15
4.1.2	Memory Controller	15
4.1.3	Sequence Controller	15
4.1.4	Look-Up Table	16
4.1.5	LCD Interface	16
4.1.6	Power Save	16
<b>5</b>	<b>Pins</b>	<b>17</b>
5.1	Pinout Diagram	17
5.2	Pin Description	18
5.2.1	Host Interface	18
5.2.2	LCD Interface	20
5.2.3	Clock Input	21
5.2.4	Miscellaneous	21
5.2.5	Power Supply	21
5.3	Summary of Configuration Options	22
5.4	Host Bus Interface Pin Mapping	22
5.5	LCD Interface Pin Mapping	23
<b>6</b>	<b>D.C. Characteristics</b>	<b>24</b>
<b>7</b>	<b>A.C. Characteristics</b>	<b>26</b>
7.1	Bus Interface Timing	26
7.1.1	SH-4 Interface Timing	26
7.1.2	SH-3 Interface Timing	28
7.1.3	Motorola MC68K #1 Interface Timing	30
7.1.4	Motorola MC68K #2 Interface Timing	31

7.1.5	Generic #1 Interface Timing . . . . .	32
7.1.6	Generic #2 Interface Timing . . . . .	33
7.2	Clock Input Requirements . . . . .	34
7.3	Display Interface . . . . .	35
7.3.1	Power On/Reset Timing . . . . .	35
7.3.2	Power Down/Up Timing . . . . .	36
7.3.3	Single Monochrome 4-Bit Panel Timing . . . . .	37
7.3.4	Single Monochrome 8-Bit Panel Timing . . . . .	39
7.3.5	Single Color 4-Bit Panel Timing . . . . .	41
7.3.6	Single Color 8-Bit Panel Timing (Format 1) . . . . .	43
7.3.7	Single Color 8-Bit Panel Timing (Format 2) . . . . .	45
7.3.8	Dual Monochrome 8-Bit Panel Timing . . . . .	47
7.3.9	Dual Color 8-Bit Panel Timing . . . . .	49
7.3.10	9/12-Bit TFT/MD-TFD Panel Timing . . . . .	51
<b>8</b>	<b>Registers . . . . .</b>	<b>54</b>
8.1	Register Mapping . . . . .	54
8.2	Register Descriptions . . . . .	54
<b>9</b>	<b>Frame Rate Calculation . . . . .</b>	<b>68</b>
<b>10</b>	<b>Display Data Formats . . . . .</b>	<b>69</b>
<b>11</b>	<b>Look-Up Table Architecture . . . . .</b>	<b>70</b>
11.1	Monochrome Modes . . . . .	70
11.2	Color Modes . . . . .	72
<b>12</b>	<b>SwivelView™ . . . . .</b>	<b>76</b>
12.1	Default SwivelView Mode . . . . .	76
12.1.1	How to Set Up Default SwivelView Mode . . . . .	77
12.2	Alternate SwivelView Mode . . . . .	78
12.2.1	How to Set Up Alternate SwivelView Mode . . . . .	79
12.3	Comparison Between Default and Alternate SwivelView Modes . . . . .	80
12.4	SwivelView Mode Limitations . . . . .	80
<b>13</b>	<b>Power Save Modes . . . . .</b>	<b>81</b>
13.1	Software Power Save Mode . . . . .	81
13.2	Hardware Power Save Mode . . . . .	81
13.3	Power Save Mode Function Summary . . . . .	82
13.4	Panel Power Up/Down Sequence . . . . .	82
13.5	Turning Off BCLK Between Accesses . . . . .	83
13.6	Clock Requirements . . . . .	84
<b>14</b>	<b>Mechanical Data . . . . .</b>	<b>85</b>

## List of Tables

Table 5-1: Summary of Power On/Reset Options . . . . .	22
Table 5-2: Host Bus Interface Pin Mapping . . . . .	22
Table 5-3: LCD Interface Pin Mapping . . . . .	23
Table 6-1: Absolute Maximum Ratings . . . . .	24
Table 6-2: Recommended Operating Conditions for Core VDD = 3.3V ± 10% . . . . .	24
Table 6-3: Input Specifications . . . . .	24
Table 6-4: Output Specifications. . . . .	25
Table 7-1: SH-4 Timing . . . . .	27
Table 7-2: SH-3 Bus Timing . . . . .	29
Table 7-3: MC68K #1 Bus Timing (MC68000) . . . . .	30
Table 7-4: MC68K #2 Timing (MC68030) . . . . .	31
Table 7-5: Generic #1 Timing . . . . .	32
Table 7-6: Generic #2 Timing . . . . .	33
Table 7-7: Clock Input Requirements . . . . .	34
Table 7-8: LCD Panel Power On/Reset Timing . . . . .	35
Table 7-9: Power Down/Up Timing . . . . .	36
Table 7-10: Single Monochrome 4-Bit Panel A.C. Timing . . . . .	38
Table 7-11: Single Monochrome 8-Bit Panel A.C. Timing . . . . .	40
Table 7-12: Single Color 4-Bit Panel A.C. Timing . . . . .	42
Table 7-13: Single Color 8-Bit Panel A.C. Timing (Format 1) . . . . .	44
Table 7-14: Single Color 8-Bit Panel A.C. Timing (Format 2) . . . . .	46
Table 7-15: Dual Monochrome 8-Bit Panel A.C. Timing . . . . .	48
Table 7-16: Dual Color 8-Bit Panel A.C. Timing . . . . .	50
Table 7-17: TFT/MD-TFD A.C. Timing . . . . .	53
Table 8-1: Panel Data Format . . . . .	55
Table 8-2: Gray Scale/Color Mode Selection . . . . .	56
Table 8-3: High Performance Selection . . . . .	56
Table 8-4: Inverse Video Mode Select Options . . . . .	57
Table 8-5: Hardware Power Save/GPIO0 Operation . . . . .	58
Table 8-6: Software Power Save Mode Selection . . . . .	58
Table 8-7: Selection of SwivelView Mode . . . . .	66
Table 8-8: Selection of PCLK and MCLK in SwivelView Mode . . . . .	67
Table 12-1: Default and Alternate SwivelView Mode Comparison . . . . .	80
Table 13-1: Power Save Mode Selection . . . . .	81
Table 13-2: Software Power Save Mode Summary . . . . .	81
Table 13-3: Hardware Power Save Mode Summary . . . . .	81
Table 13-4: Power Save Mode Function Summary . . . . .	82
Table 13-5: SED1375 Internal Clock Requirements . . . . .	84

**THIS PAGE LEFT BLANK**

## List of Figures

Figure 3-1: Typical System Diagram (SH-4 Bus) . . . . .	12
Figure 3-2: Typical System Diagram (SH-3 Bus) . . . . .	12
Figure 3-3: Typical System Diagram (M68K #1 Bus) . . . . .	13
Figure 3-4: Typical System Diagram (M68K #2 Bus) . . . . .	13
Figure 3-5: Typical System Diagram (Generic #1 Bus) . . . . .	14
Figure 3-6: Typical System Diagram (Generic #2 Bus - e.g. ISA Bus) . . . . .	14
Figure 4-1: System Block Diagram Showing Data Paths . . . . .	15
Figure 5-1: Pinout Diagram . . . . .	17
Figure 7-1: SH-4 Timing . . . . .	26
Figure 7-2: SH-3 Bus Timing . . . . .	28
Figure 7-3: MC68K #1 Bus Timing (MC68000) . . . . .	30
Figure 7-4: MC68K #2 Timing (MC68030) . . . . .	31
Figure 7-5: Generic #1 Timing . . . . .	32
Figure 7-6: Generic #2 Timing . . . . .	33
Figure 7-7: Clock Input Requirements . . . . .	34
Figure 7-8: LCD Panel Power On/Reset Timing . . . . .	35
Figure 7-9: Power Down/Up Timing . . . . .	36
Figure 7-10: Single Monochrome 4-Bit Panel Timing . . . . .	37
Figure 7-11: Single Monochrome 4-Bit Panel A.C. Timing . . . . .	38
Figure 7-12: Single Monochrome 8-Bit Panel Timing . . . . .	39
Figure 7-13: Single Monochrome 8-Bit Panel A.C. Timing . . . . .	40
Figure 7-14: Single Color 4-Bit Panel Timing . . . . .	41
Figure 7-15: Single Color 4-Bit Panel A.C. Timing . . . . .	42
Figure 7-16: Single Color 8-Bit Panel Timing (Format 1) . . . . .	43
Figure 7-17: Single Color 8-Bit Panel A.C. Timing (Format 1) . . . . .	44
Figure 7-18: Single Color 8-Bit Panel Timing (Format 2) . . . . .	45
Figure 7-19: Single Color 8-Bit Panel A.C. Timing (Format 2) . . . . .	46
Figure 7-20: Dual Monochrome 8-Bit Panel Timing . . . . .	47
Figure 7-21: Dual Monochrome 8-Bit Panel A.C. Timing . . . . .	48
Figure 7-22: Dual Color 8-Bit Panel Timing . . . . .	49
Figure 7-23: Dual Color 8-Bit Panel A.C. Timing . . . . .	50
Figure 7-24: 12-Bit TFT/MD-TFD Panel Timing . . . . .	51
Figure 7-25: TFT/MD-TFD A.C. Timing . . . . .	52
Figure 8-1: Screen-Register Relationship, Split Screen. . . . .	64
Figure 10-1: 1/2/4/8 Bit-Per-Pixel Display Data Memory Organization. . . . .	69
Figure 11-1: 1 Bit-per-pixel Monochrome Mode Data Output Path . . . . .	70
Figure 11-2: 2 Bit-per-pixel Monochrome Mode Data Output Path . . . . .	70

Figure 11-3: 4 Bit-per-pixel Monochrome Mode Data Output Path . . . . . .71

Figure 11-4: 1 Bit-per-pixel Color Mode Data Output Path . . . . . .72

Figure 11-5: 2 Bit-per-pixel Color Mode Data Output Path . . . . . .73

Figure 11-6: 4 Bit-per-pixel Color Mode Data Output Path . . . . . .74

Figure 11-7: 8 Bit-per-pixel Color Mode Data Output Path . . . . . .75

Figure 12-1: Relationship Between The Screen Image  
and the Image Refreshed by SED1375 in Default Mode . . . . . .76

Figure 12-2: Relationship Between The Screen Image  
and the Image Refreshed by SED1375 in Alternate Mode . . . . . .78

Figure 13-1: Panel On/Off Sequence . . . . . .83

Figure 14-1: Mechanical Drawing QFP14 . . . . . .85



---

# 1 Introduction

## 1.1 Scope

This is the Hardware Functional Specification for the SED1375 Embedded Memory LCD Controller Chip. Included in this document are timing diagrams, AC and DC characteristics, register descriptions, and power management descriptions. This document is intended for two audiences: Video Subsystem Designers and Software Developers.

Please check the Epson Electronics America website at <http://www.eea.epson.com> for the latest revision of this document before beginning any development.

We appreciate your comments on our documentation. Please contact us via email at [techpubs@erd.epson.com](mailto:techpubs@erd.epson.com).

## 1.2 Overview Description

The SED1375 is a color / monochrome LCD graphics controller with an embedded 80K byte SRAM display buffer. The high integration of the SED1375 provides a low cost, low power, single chip solution to meet the requirements of embedded markets such as Office Automation equipment, Mobile Communications devices, and Hand-Held PCs where board size and battery life are major concerns.

Products requiring a "Portrait" display can take advantage of the SwivelView™ Mode feature of the SED1375. Virtual and Split Screen are just some of the display modes supported. The above features, combined with the Operating System independence of the SED1375, make it the ideal solution for a wide variety of applications.

## 2 Features

### 2.1 Integrated Frame Buffer

- Embedded 80K byte SRAM display buffer.

### 2.2 CPU Interface

- Direct support of the following interfaces:
  - Hitachi SH-3.
  - Hitachi SH-4.
  - Motorola M68K.
  - MPU bus interface using WAIT# signal.
- Direct memory mapping of internal registers.
- Single level CPU write buffer.
- Registers are mapped into upper 32 bytes of 128K byte address space.
- The complete 80K byte display buffer is directly and contiguously available through the 17-bit address bus.

### 2.3 Display Support

- 4/8-bit monochrome LCD interface.
- 4/8-bit color LCD interface.
- Single-panel, single-drive passive displays.
- Dual-panel, dual-drive passive displays.
- Active Matrix TFT / MD-TFD interface
- Register level support for EL panels.
- Example resolutions:
  - 640x480 at a color depth of 2 bpp
  - 640x240 at a color depth of 4 bpp
  - 320x240 at a color depth of 8 bpp

## 2.4 Display Modes

- SwivelView™: direct 90° hardware rotation of display image for portrait mode display
- 1/2/4 bit-per-pixel (bpp), 2/4/16-level grayscale display.
- 1/2/4/8 bit-per-pixel, 2/4/16/256-level color display.
- Up to 16 shades of gray by FRM on monochrome passive LCD panels; a 256x4 Look-Up Table is used to map 1/2/4 bpp modes into these shades.
- 256 simultaneous of 4096 colors on color passive and active matrix LCD panels; three 256x4 Look-Up Tables are used to map 1/2/4/8 bpp modes into these colors.
- Split screen display for all landscape panel modes allows two different images to be simultaneously displayed.
- Virtual display support (displays images larger than the panel size through the use of panning).

## 2.5 Clock Source

- Maximum operating clock (CLK) frequency of 25MHz.
- Operating clock (CLK) is derived from CLKI input.  
CLK = CLKI  
or  
CLK = CLKI/2
- Pixel Clock (PCLK) and Memory Clock (MCLK) are derived from CLK.

## 2.6 Miscellaneous

- Hardware/Software Video Invert.
- Software Power Save mode.
- Hardware Power Save mode.
- LCD power-down sequencing.
- 5 General Purpose Input/Output pins are available.
  - GPIO0 is available if Hardware Power Save is not required.
  - GPIO[4:1] are available if upper LCD data pins (FPDAT[11:8]) are not required for TFT/MD-TFD support or hardware inverse video.
- Core operates from 2.7 volts to 3.6 volts.
- IO Operates from the core voltage up to 5.5 volts.

## 2.7 Package

- 80 pin QFP14 package.

### 3 Typical System Implementation Diagrams

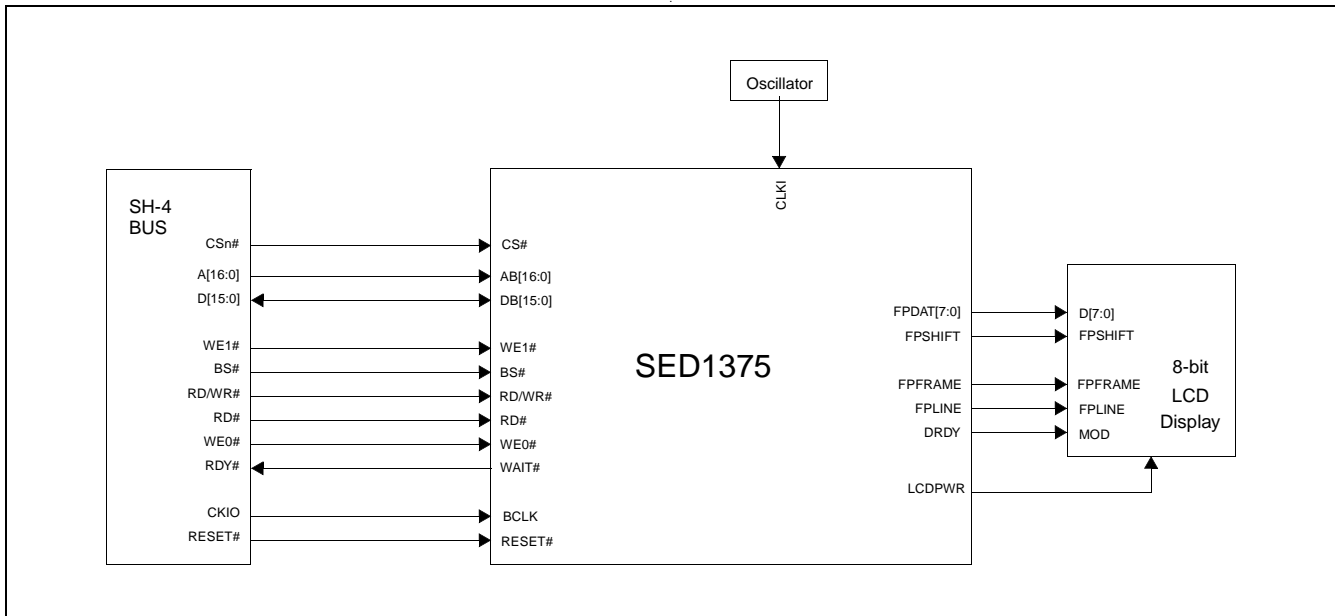

Figure 3-1: Typical System Diagram (SH-4 Bus)

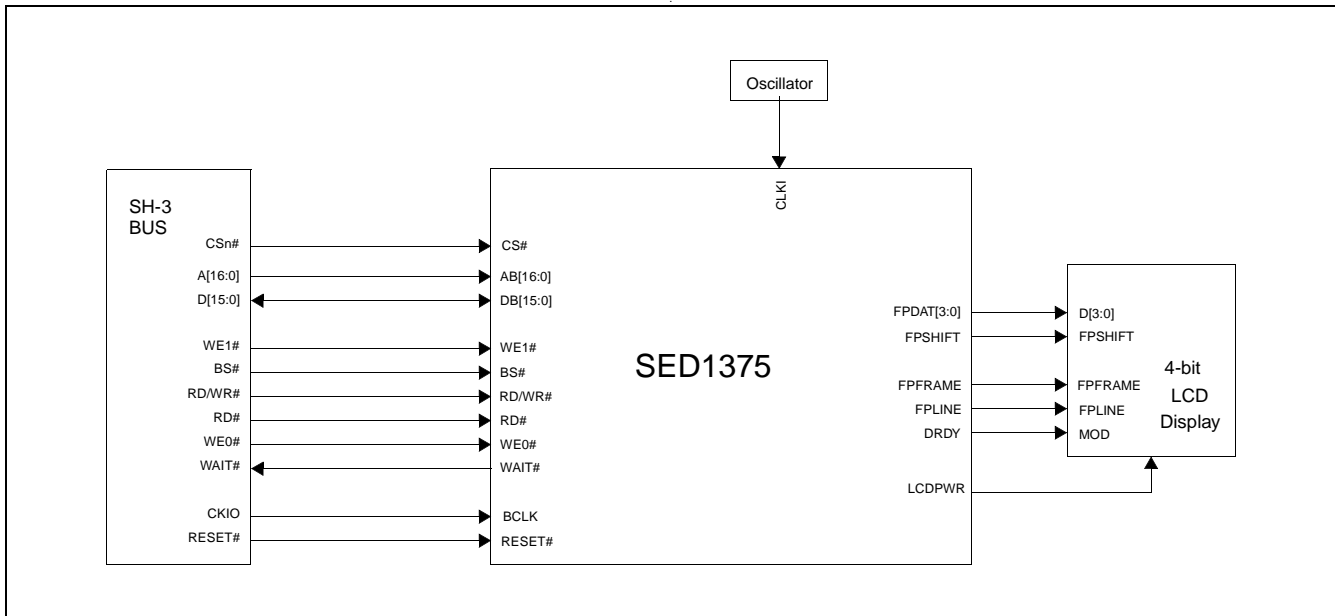

Figure 3-2: Typical System Diagram (SH-3 Bus)

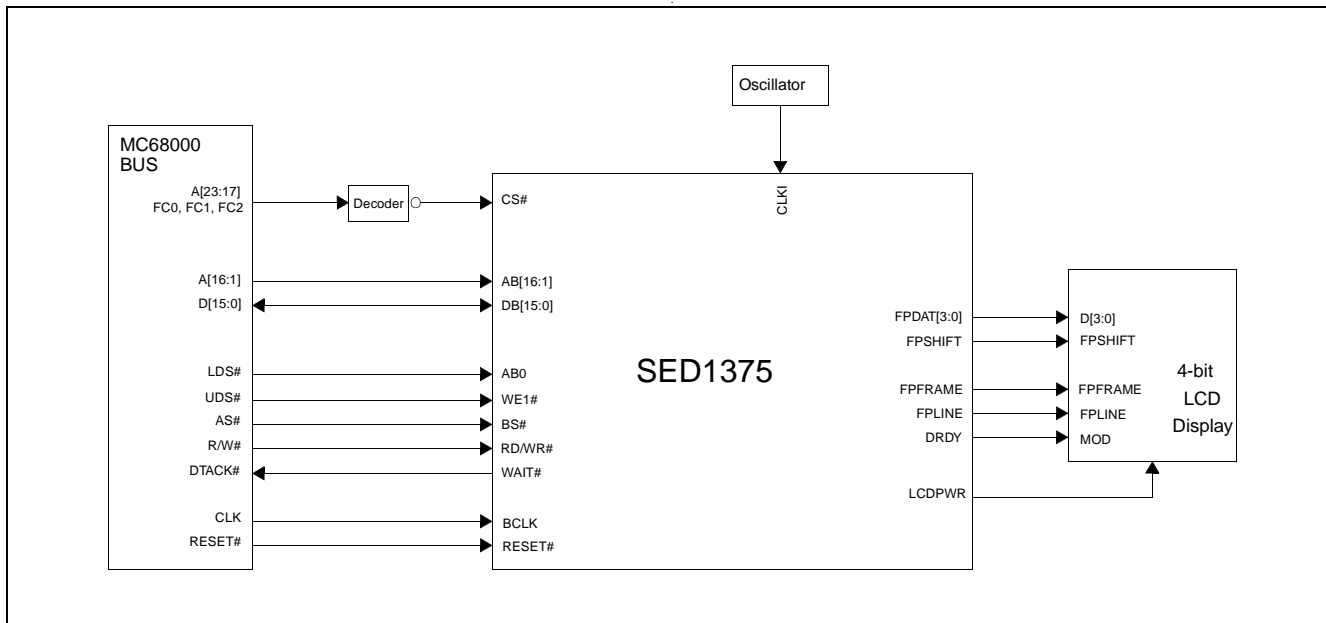

Figure 3-3: Typical System Diagram (M68K #1 Bus)

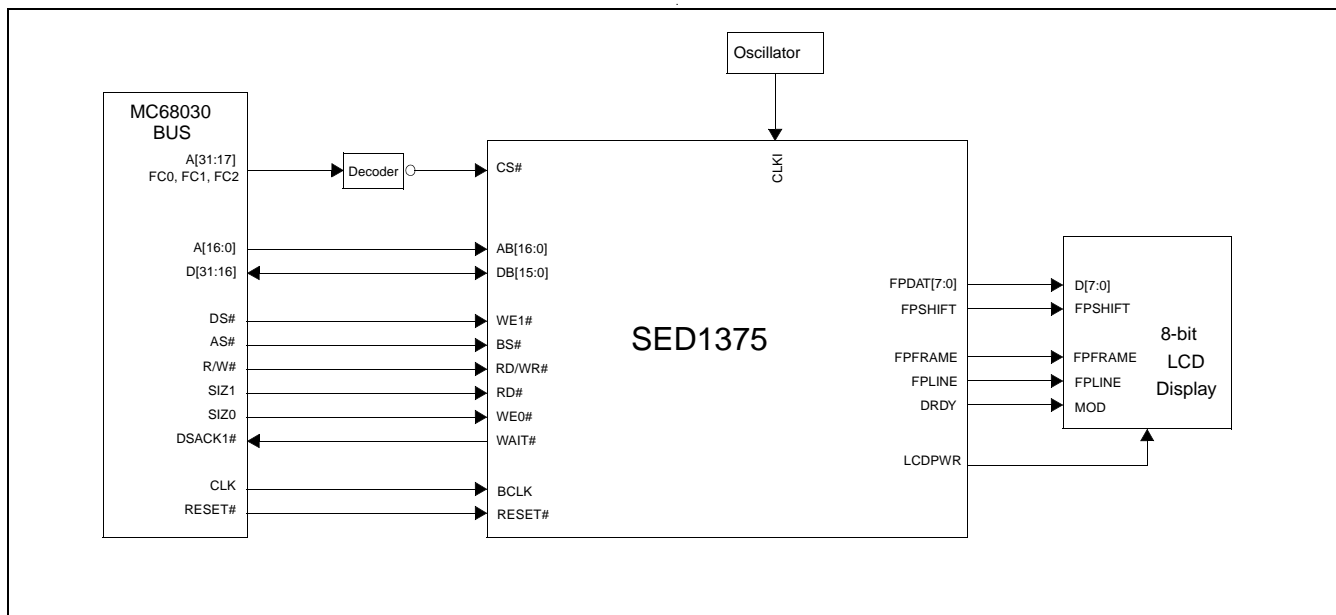

Figure 3-4: Typical System Diagram (M68K #2 Bus)

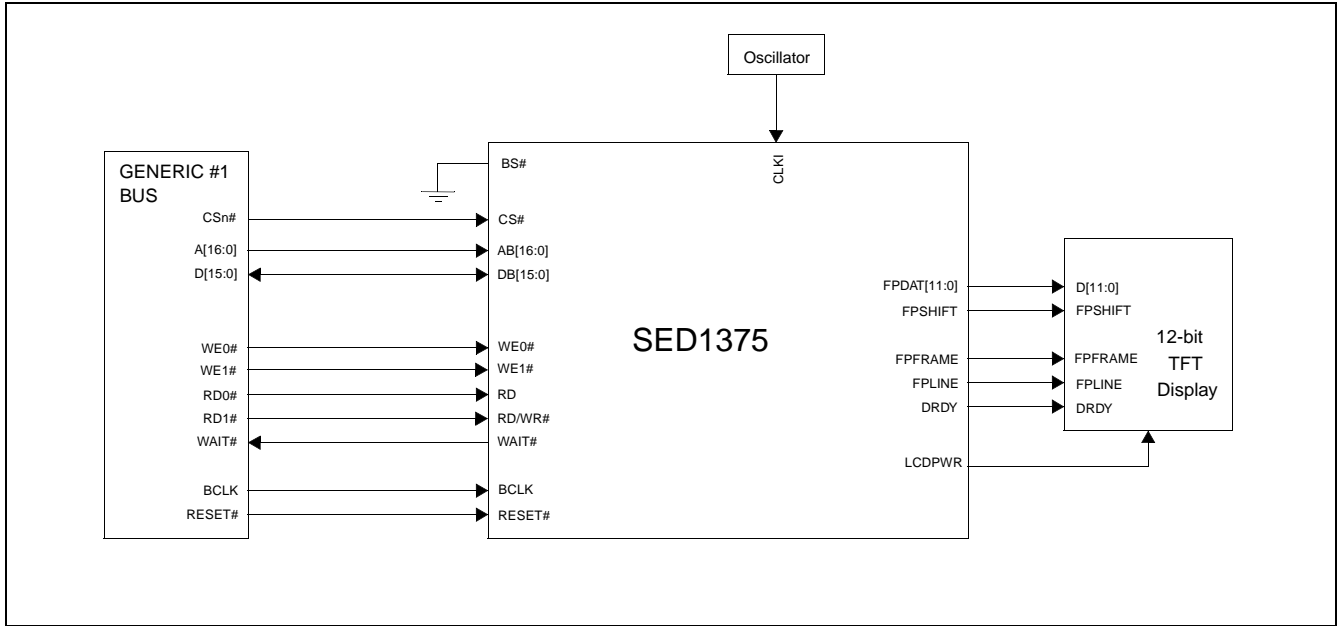

Figure 3-5: Typical System Diagram (Generic #1 Bus)

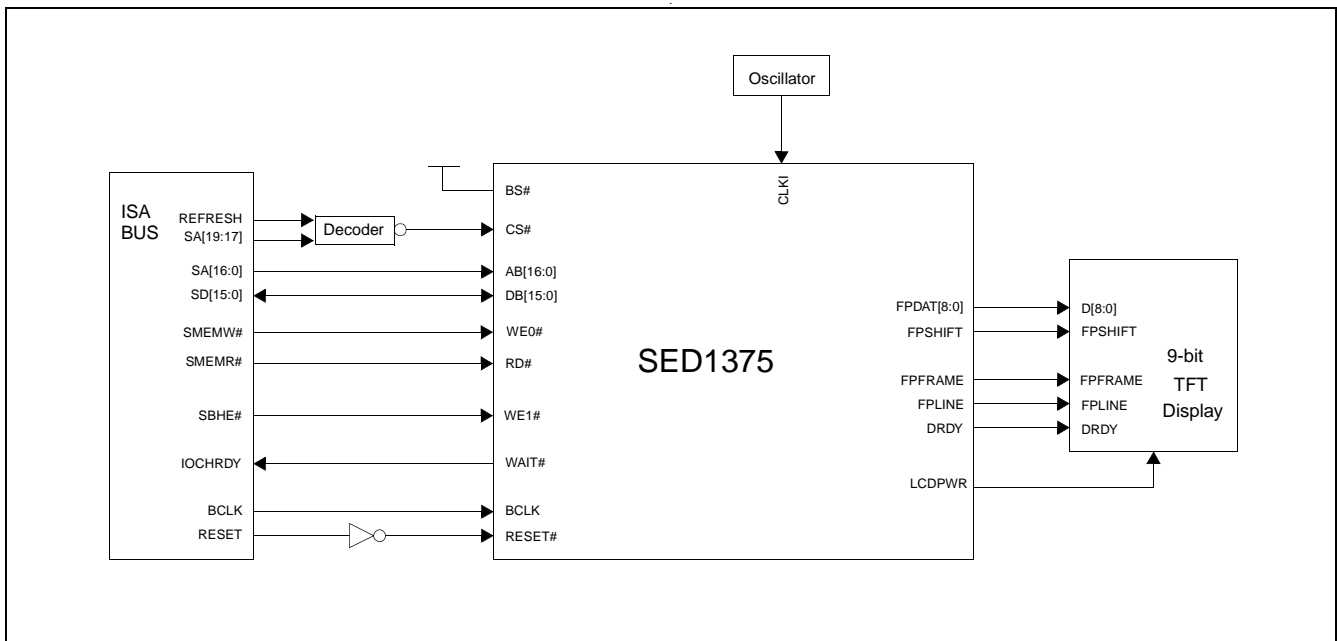

Figure 3-6: Typical System Diagram (Generic #2 Bus - e.g. ISA Bus)

## 4 Functional Block Diagram

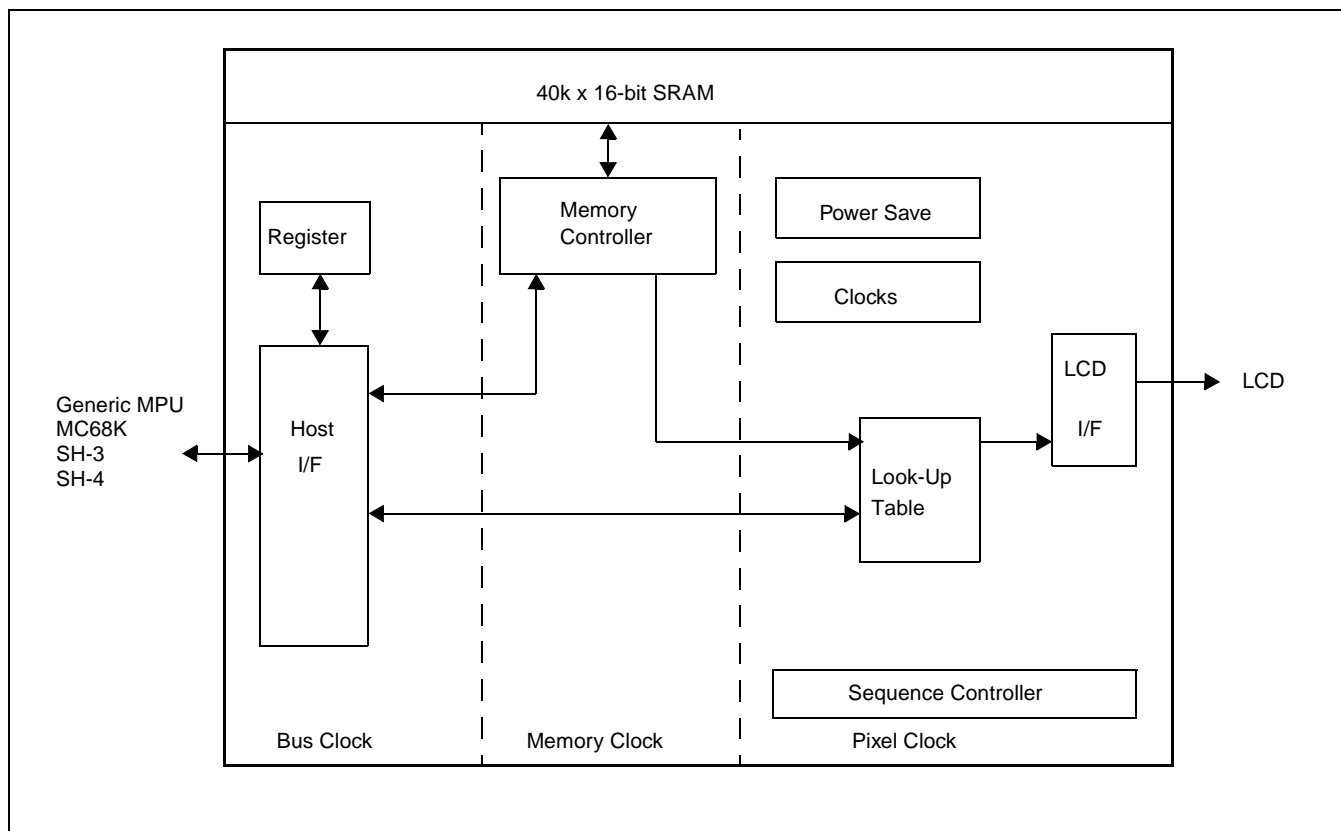

Figure 4-1: System Block Diagram Showing Data Paths

### 4.1 Functional Block Descriptions

#### 4.1.1 Host Interface

The Host Interface provides the means for the CPU/MPU to communicate with the display buffer and internal registers.

#### 4.1.2 Memory Controller

The Memory Controller arbitrates between CPU accesses and display refresh accesses. It also generates the necessary signals to control the SRAM frame buffer.

#### 4.1.3 Sequence Controller

The Sequence Controller controls data flow from the Memory Controller through the Look-Up Table and to the LCD Interface. It also generates memory addresses for display refresh accesses.

#### **4.1.4 Look-Up Table**

The Look-Up Table contains three 256x4 Look-Up Tables or palettes, one for each primary color. In monochrome mode only the green Look-Up Table is used.

#### **4.1.5 LCD Interface**

The LCD Interface performs frame rate modulation for passive LCD panels. It also generates the correct data format and timing control signals for various LCD and TFT/MD-TFD panels.

#### **4.1.6 Power Save**

Power Save contains the power save mode circuitry.



# 5 Pins

## 5.1 Pinout Diagram

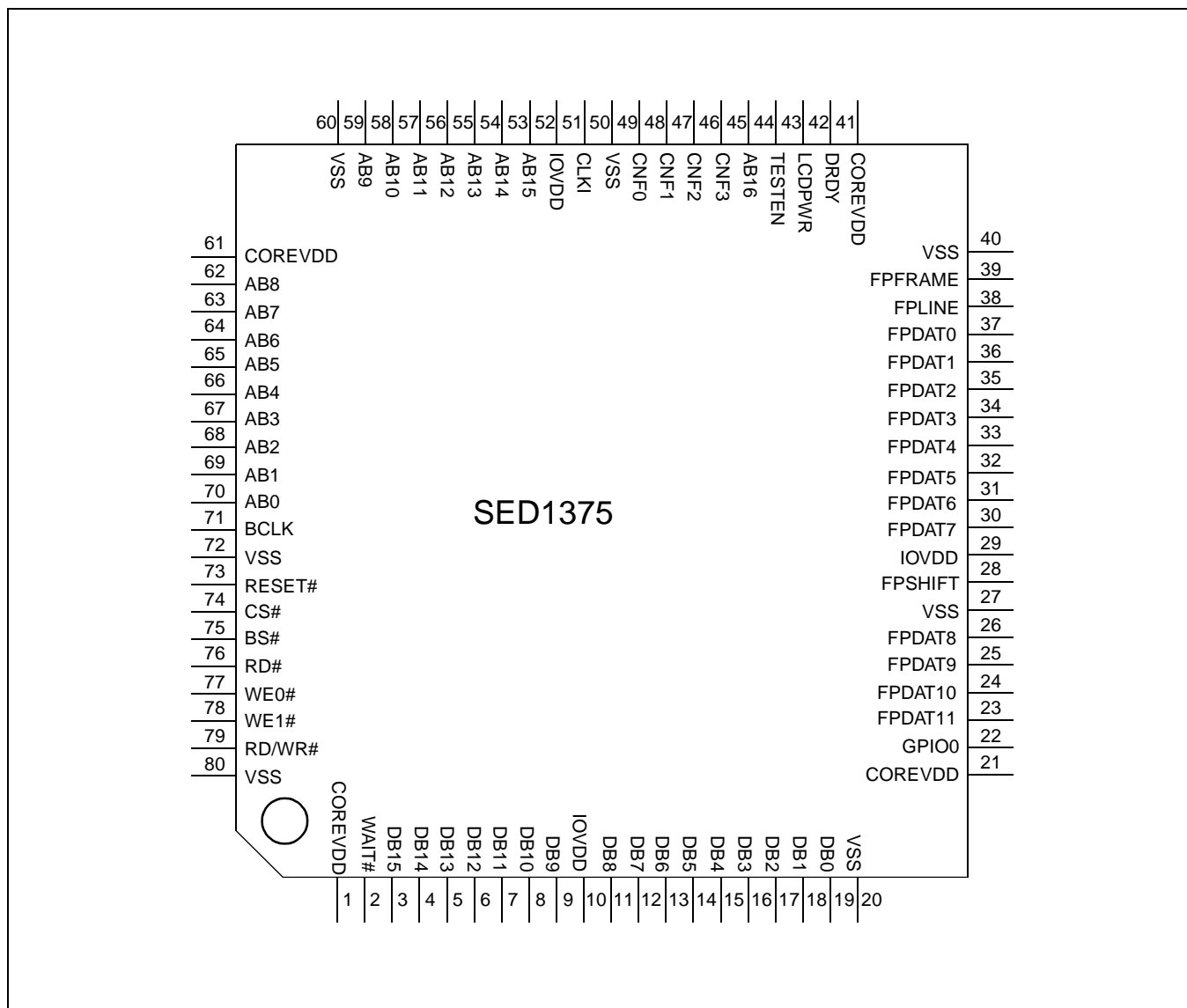

Figure 5-1: Pinout Diagram

**Note**

Package type: 80 pin surface mount QFP14

## 5.2 Pin Description

### Key:

I	=	Input
O	=	Output
IO	=	Bi-Directional (Input/Output)
P	=	Power pin
C	=	CMOS level input
CS	=	CMOS level Schmitt input
COx	=	CMOS output driver, x denotes driver type (see I <sub>OL</sub> /I <sub>OH</sub> in Table 6-4: "Output Specifications," on page 25)
TSx	=	Tri-state CMOS output driver, x denotes driver type (see I <sub>OL</sub> /I <sub>OH</sub> in Table 6-4: "Output Specifications," on page 25)
CNx	=	CMOS low-noise output driver, x denotes driver type (see I <sub>OL</sub> /I <sub>OH</sub> in Table 6-4: "Output Specifications," on page 25)
TEST	=	CMOS level test input with pull down resistor

### 5.2.1 Host Interface

Pin Names	Type	Pin #	Cell	RESET# State	Description
AB0	I	70	CS	Input	This pin has multiple functions. <ul style="list-style-type: none"> <li>• For SH-3/SH-4 mode, this pin inputs system address bit 0 (A0).</li> <li>• For MC68K #1, this pin inputs the lower data strobe (LDS#).</li> <li>• For MC68K #2, this pin inputs system address bit 0 (A0).</li> <li>• For Generic #1, this pin inputs system address bit 0 (A0).</li> <li>• For Generic #2, this pin inputs system address bit 0 (A0).</li> </ul> See Table 5-2: "Host Bus Interface Pin Mapping," on page 22 for summary.
AB[16:1]	I	45, 53, 54, 55, 56, 57, 58, 59, 62, 63, 64, 65, 66, 67, 68, 69	C	Input	These pins input the system address bits 16 through 1 (A[16:1]).
DB[15:0]	IO	3, 4, 5, 6, 7, 8, 9, 11, 12, 13, 14, 15, 16, 17, 18, 19	C/TS2	Hi-Z	These pins have multiple functions. <ul style="list-style-type: none"> <li>• For SH-3/SH-4 mode, these pins are connected to D[15:0].</li> <li>• For MC68K #1, these pins are connected to D[15:0].</li> <li>• For MC68K #2, these pins are connected to D[31:16] for a 32-bit device (e.g. MC68030) or D[15:0] for a 16-bit device (e.g. MC68340).</li> <li>• For Generic #1, these pins are connected to D[15:0].</li> <li>• For Generic #2, these pins are connected to D[15:0].</li> </ul> See Table 5-2: "Host Bus Interface Pin Mapping," on page 22 for summary.

Pin Names	Type	Pin #	Cell	RESET# State	Description
WE0#	I	77	CS	Input	<p>This pin has multiple functions.</p> <ul style="list-style-type: none"> <li>For SH-3/SH-4 mode, this pin inputs the write enable signal for the lower data byte (WE0#).</li> <li>For MC68K #1, this pin must be tied to IO V<sub>DD</sub>.</li> <li>For MC68K #2, this pin inputs the bus size bit 0 (SIZ0).</li> <li>For Generic #1, this pin inputs the write enable signal for the lower data byte (WE0#).</li> <li>For Generic #2, this pin inputs the write enable signal (WE#).</li> </ul> <p>See Table 5-2: "Host Bus Interface Pin Mapping," on page 22 for summary.</p>
WE1#	I	78	CS	Input	<p>This pin has multiple functions.</p> <ul style="list-style-type: none"> <li>For SH-3/SH-4 mode, this pin inputs the write enable signal for the upper data byte (WE1#).</li> <li>For MC68K #1, this pin inputs the upper data strobe (UDS#).</li> <li>For MC68K #2, this pin inputs the data strobe (DS#).</li> <li>For Generic #1, this pin inputs the write enable signal for the upper data byte (WE1#).</li> <li>For Generic #2, this pin inputs the byte enable signal for the high data byte (BHE#).</li> </ul> <p>See Table 5-2: "Host Bus Interface Pin Mapping," on page 22 for summary.</p>
CS#	I	74	C	Input	This pin inputs the chip select signal.
BCLK	I	71	C	Input	This pin inputs the system bus clock.
BS#	I	75	CS	Input	<p>This pin has multiple functions.</p> <ul style="list-style-type: none"> <li>For SH-3/SH-4 mode, this pin inputs the bus start signal (BS#).</li> <li>For MC68K #1, this pin inputs the address strobe (AS#).</li> <li>For MC68K #2, this pin inputs the address strobe (AS#).</li> <li>For Generic #1, this pin must be tied to V<sub>SS</sub>.</li> <li>For Generic #2, this pin must be tied to IO V<sub>DD</sub>.</li> </ul> <p>See Table 5-2: "Host Bus Interface Pin Mapping," on page 22 for summary.</p>
RD/WR#	I	79	CS	Input	<p>This pin has multiple functions.</p> <ul style="list-style-type: none"> <li>For SH-3/SH-4 mode, this pin inputs the RD/WR# signal. The SED1375 needs this signal for early decode of the bus cycle.</li> <li>For MC68K #1, this pin inputs the R/W# signal.</li> <li>For MC68K #2, this pin inputs the R/W# signal.</li> <li>For Generic #1, this pin inputs the read command for the upper data byte (RD1#).</li> <li>For Generic #2, this pin must be tied to IO V<sub>DD</sub>.</li> </ul> <p>See Table 5-2: "Host Bus Interface Pin Mapping," on page 22 for summary.</p>

Pin Names	Type	Pin #	Cell	RESET# State	Description
RD#	I	76	CS	Input	<p>This pin has multiple functions.</p> <ul style="list-style-type: none"> <li>For SH-3/SH-4 mode, this pin inputs the read signal (RD#).</li> <li>For MC68K #1, this pin must be tied to IO V<sub>DD</sub>.</li> <li>For MC68K #2, this pin inputs the bus size bit 1 (SIZ1).</li> <li>For Generic #1, this pin inputs the read command for the lower data byte (RD0#).</li> <li>For Generic #2, this pin inputs the read command (RD#).</li> </ul> <p>See Table 5-2: "Host Bus Interface Pin Mapping," on page 22 for summary.</p>
WAIT#	O	2	TS2	Hi-Z	<p>This pin has multiple functions.</p> <ul style="list-style-type: none"> <li>For SH-3 mode, this pin outputs the wait request signal (WAIT#).</li> <li>For SH-4 mode, this pin outputs the device ready signal (RDY#).</li> <li>For MC68K #1, this pin outputs the data transfer acknowledge signal (DTACK#).</li> <li>For MC68K #2, this pin outputs the data transfer and size acknowledge bit 1 (DSACK1#).</li> <li>For Generic #1, this pin outputs the wait signal (WAIT#).</li> <li>For Generic #2, this pin outputs the wait signal (WAIT#).</li> </ul> <p>See Table 5-2: "Host Bus Interface Pin Mapping," on page 22 for summary.</p>
RESET#	I	73	CS	0	Active low input to set all internal registers to the default state and to force all signals to their inactive states.

## 5.2.2 LCD Interface

Pin Name	Type	Pin #	Cell	RESET# State	Description
FPDAT[7:0]	O	30, 31, 32, 33, 34, 35, 36, 37	CN3	0	Panel Data
FPDAT[10:8]	O, IO	24, 25, 26	CN3	Input	<p>These pins have multiple functions.</p> <ul style="list-style-type: none"> <li>Panel Data bits [10:8] for TFT/MD-TFD panels.</li> <li>General Purpose Input/Output pins GPIO[3:1].</li> </ul> <p>These pins should be connected to IO V<sub>DD</sub> when unused. See Table 5-3: "LCD Interface Pin Mapping," on page 23 for summary.</p>
FPDAT11	O, IO	23	CN3	Input	<p>This pin has multiple functions.</p> <ul style="list-style-type: none"> <li>Panel Data bit 11 for TFT/MD-TFD panels.</li> <li>General Purpose Input/Output pin GPIO4.</li> <li>Inverse Video select pin.</li> </ul> <p>This pin should be connected to IO V<sub>DD</sub> when unused. See Table 5-3: "LCD Interface Pin Mapping," on page 23 for summary.</p>
FPFRAME	O	39	CN3	0	Frame Pulse

Pin Name	Type	Pin #	Cell	RESET# State	Description
FPLINE	O	38	CN3	0	Line Pulse
FPSHIFT	O	28	CN3	0	Shift Clock
LCDPWR	O	43	CO1	0	Active high LCD Power Control
DRDY	O	42	CN3	0	This pin has multiple functions. <ul style="list-style-type: none"> <li>TFT/MD-TFD Display Enable (DRDY).</li> <li>LCD Backplane Bias (MOD).</li> <li>Second Shift Clock (FPSHIFT2).</li> </ul> See Table 5-3: "LCD Interface Pin Mapping," on page 23 for summary.

### 5.2.3 Clock Input

Pin Name	Type	Pin #	Driver	Description
CLKI	I	51	C	Input Clock

### 5.2.4 Miscellaneous

Pin Name	Type	Pin #	Cell	RESET# State	Description
CNF[3:0]	I	46, 47, 48, 49	C	As set by hardware	These inputs are used to configure the SED1375 - see Table 5-1: "Summary of Power On/Reset Options," on page 22. Must be connected directly to IO $V_{DD}$ or $V_{SS}$ .
GPIO0	IO, I	22	CS/ TS1	Input	This pin has multiple functions - see REG[03h] bit 2. <ul style="list-style-type: none"> <li>General Purpose Input/Output pin.</li> <li>Hardware Power Save.</li> </ul>
TESTEN	I	44	TEST	pulled low	Test Enable input. This input must be connected to $V_{SS}$ .

### 5.2.5 Power Supply

Pin Name	Type	Pin #	Driver	Description
COREVDD	P	1, 21, 41, 61	P	Core $V_{DD}$
IOVDD	P	10, 29, 52	P	IO $V_{DD}$
VSS	P	20, 27, 40, 50, 60, 72, 80	P	Common $V_{SS}$

## 5.3 Summary of Configuration Options

Table 5-1: Summary of Power On/Reset Options

Configuration Pin	Power On/Reset State				
	1	0			
CNF3	Big Endian	Little Endian			
CNF[2:0]	Select host bus interface as follows:				
	<b>CNF2</b>	<b>CNF1</b>	<b>CNF0</b>	<b>BS#</b>	<b>Host Bus</b>
	0	0	0	X	SH-4 interface
	0	0	1	X	SH-3 interface
	0	1	0	X	reserved
	0	1	1	X	MC68K #1, 16-bit
	1	0	0	X	reserved
	1	0	1	X	MC68K #2, 16-bit
	1	1	0	0	reserved
	1	1	0	1	reserved
1	1	1	0	Generic #1, 16-bit	
1	1	1	1	Generic #2, 16-bit	

## 5.4 Host Bus Interface Pin Mapping

Table 5-2: Host Bus Interface Pin Mapping

SED1375 Pin Names	SH-3	SH-4	MC68K #1	MC68K #2	Generic #1	Generic #2
AB[16:1]	A[16:1]	A[16:1]	A[16:1]	A[16:1]	A[16:1]	A[16:1]
AB0	A0	A0	LDS#	A0	A0	A0
DB[15:0]	D[15:0]	D[15:0]	D[15:0]	D[31:16]	D[15:0]	D[15:0]
WE1#	WE1#	WE1#	UDS#	DS#	WE1#	BHE#
CS#	CSn#	CSn#	External Decode	External Decode	External Decode	External Decode
BCLK	CKIO	CKIO	CLK	CLK	BCLK	BCLK
BS#	BS#	BS#	AS#	AS#	connect to V <sub>SS</sub>	connect to IO V <sub>DD</sub>
RD/WR#	RD/WR#	RD/WR#	R/W#	R/W#	RD1#	connect to IO V <sub>DD</sub>
RD#	RD#	RD#	connect to IO V <sub>DD</sub>	SIZ1	RD0#	RD#
WE0#	WE0#	WE0#	connect to IO V <sub>DD</sub>	SIZ0	WE0#	WE#
WAIT#	WAIT#	RDY#	DTACK#	DSACK1#	WAIT#	WAIT#
RESET#	RESET#	RESET#	RESET#	RESET#	RESET#	RESET#

## 5.5 LCD Interface Pin Mapping

Table 5-3: LCD Interface Pin Mapping

SED1375 Pin Name	Monochrome Passive Panel			Color Passive Panel				Color TFT/MD-TFD	
	4-bit Single	8-bit Single	8-bit Dual	4-bit Single	8-bit Single Format 1	8-bit Single Format 2	8-bit Dual	9-bit	12-bit
FPPFRAME	FPPFRAME								
FPLINE	FPLINE								
FPSHIFT	FPSHIFT								
DRDY	MOD	MOD	MOD	MOD	FPSHIFT2	MOD	MOD	DRDY	
FPDAT0	driven 0	D0	LD0	driven 0	D0	D0	LD0	R2	R3
FPDAT1	driven 0	D1	LD1	driven 0	D1	D1	LD1	R1	R2
FPDAT2	driven 0	D2	LD2	driven 0	D2	D2	LD2	R0	R1
FPDAT3	driven 0	D3	LD3	driven 0	D3	D3	LD3	G2	G3
FPDAT4	D0	D4	UD0	D0	D4	D4	UD0	G1	G2
FPDAT5	D1	D5	UD1	D1	D5	D5	UD1	G0	G1
FPDAT6	D2	D6	UD2	D2	D6	D6	UD2	B2	B3
FPDAT7	D3	D7	UD3	D3	D7	D7	UD3	B1	B2
FPDAT8	GPIO1	GPIO1	GPIO1	GPIO1	GPIO1	GPIO1	GPIO1	B0	B1
FPDAT9	GPIO2	GPIO2	GPIO2	GPIO2	GPIO2	GPIO2	GPIO2	GPIO2	R0
FPDAT10	GPIO3	GPIO3	GPIO3	GPIO3	GPIO3	GPIO3	GPIO3	GPIO3	G0
FPDAT11	GPIO4/ Hardware Video Invert	GPIO4/ Hardware Video Invert	GPIO4/ Hardware Video Invert	GPIO4/ Hardware Video Invert	GPIO4/ Hardware Video Invert	GPIO4/ Hardware Video Invert	GPIO4/ Hardware Video Invert	GPIO4	B0

**Note**

1. Unused GPIO pins must be connected to IO  $V_{DD}$ .
2. Hardware Video Invert is enabled on FPDAT11 by REG[02h] bit 1.

## 6 D.C. Characteristics

Table 6-1: Absolute Maximum Ratings

Symbol	Parameter	Rating	Units
Core $V_{DD}$	Supply Voltage	$V_{SS} - 0.3$ to 4.0	V
IO $V_{DD}$	Supply Voltage	Core $V_{DD}$ to 7.0	V
$V_{IN}$	Input Voltage	$V_{SS} - 0.3$ to IO $V_{DD} + 0.5$	V
$V_{OUT}$	Output Voltage	$V_{SS} - 0.3$ to IO $V_{DD} + 0.5$	V
$T_{STG}$	Storage Temperature	-65 to 150	°C
$T_{SOL}$	Solder Temperature/Time	260 for 10 sec. max at lead	°C

Table 6-2: Recommended Operating Conditions for Core  $V_{DD} = 3.3V \pm 10\%$

Symbol	Parameter	Condition	Min	Typ	Max	Units
Core $V_{DD}$	Supply Voltage	$V_{SS} = 0$ V	2.7	3.0/3.3	3.6	V
IO $V_{DD}$	Supply Voltage	$V_{SS} = 0$ V, IO $V_{DD} \geq$ Core $V_{DD}$	2.7	3.0/3.3/5.0	5.5	V
$V_{IN}$	Input Voltage		$V_{SS}$		IO $V_{DD}$	V
$T_{OPR}$	Operating Temperature		-40	25	85	°C

Table 6-3: Input Specifications

Symbol	Parameter	Condition	Min	Typ	Max	Units
$V_{IL}$	Low Level Input Voltage CMOS inputs	IO $V_{DD} =$ 3.0 3.3 5.0			0.8 0.8 1.0	V
$V_{IH}$	High Level Input Voltage CMOS inputs	IO $V_{DD} =$ 3.0 3.3 5.0	1.9 2.0 3.5			V
$V_{T+}$	Positive-going Threshold CMOS Schmitt inputs	IO $V_{DD} =$ 3.0 3.3 5.0	1.0 1.1 2.0		2.3 2.4 4.0	V
$V_{T-}$	Negative-going Threshold CMOS Schmitt inputs	IO $V_{DD} =$ 3.0 3.3 5.0	0.5 0.6 0.8		1.7 1.8 3.1	V
$I_{IZ}$	Input Leakage Current	$V_{DD} =$ Max $V_{IH} = V_{DD}$ $V_{IL} = V_{SS}$	-1		1	$\mu$ A
$C_{IN}$	Input Pin Capacitance				10	pF



Table 6-4: Output Specifications

Symbol	Parameter	Condition	Min	Typ	Max	Units
$I_{OL}$ (3.0V)	Low Level Output Current	$IO V_{DD} = 3.0V$ $V_O = 0.4V$ , Type = 1 2 3		1.8 5 10		mA
$I_{OL}$ (3.3V)	Low Level Output Current	$IO V_{DD} = 3.3V$ $V_O = 0.4V$ , Type = 1 2 3		2 6 12		mA
$I_{OL}$ (5.0V)	Low Level Output Current	$IO V_{DD} = 5.0V$ $V_O = 0.4V$ , Type = 1 2 3		3 8 12		mA
$I_{OH}$ (3.0V)	Low Level Output Current	$IO V_{DD} = 3.0V$ $V_O = IO V_{DD} - 0.4V$ , Type = 1 2 3		-1.8 -5 -10		mA
$I_{OH}$ (3.3V)	Low Level Output Current	$IO V_{DD} = 3.3V$ $V_O = IO V_{DD} - 0.4V$ , Type = 1 2 3		-2 -6 -12		mA
$I_{OH}$ (5.0V)	Low Level Output Current	$IO V_{DD} = 5.0V$ $V_O = IO V_{DD} - 0.4V$ , Type = 1 2 3		-3 -8 -12		mA
$V_{OL}$	Low Level Output Voltage	$I = I_{OL}$			0.4	V
$V_{OH}$	High Level Output Voltage	$I = I_{OH}$	$IO V_{DD} - 0.4$			V
$I_{OZ}$	Output Leakage Current	$V_{DD} = MAX$ $V_{OH} = V_{DD}$ $V_{OL} = V_{SS}$	-1		1	$\mu A$
$C_{OUT}$	Output Pin Capacitance				10	pF
$C_{BID}$	Bidirectional Pin Capacitance				10	pF

## 7 A.C. Characteristics

Conditions: IO  $V_{DD} = 2.7\text{ V to }5.0\text{ V}$   
 $T_A = -40^\circ\text{ C to }85^\circ\text{ C}$   
 $T_{\text{rise}}$  and  $T_{\text{fall}}$  for all inputs must be  $\leq 5\text{ nsec}$  (10% ~ 90%)  
 $C_L = 60\text{ pF}$  (Bus/MPU Interface)  
 $C_L = 60\text{ pF}$  (LCD Panel Interface)

### 7.1 Bus Interface Timing

#### 7.1.1 SH-4 Interface Timing

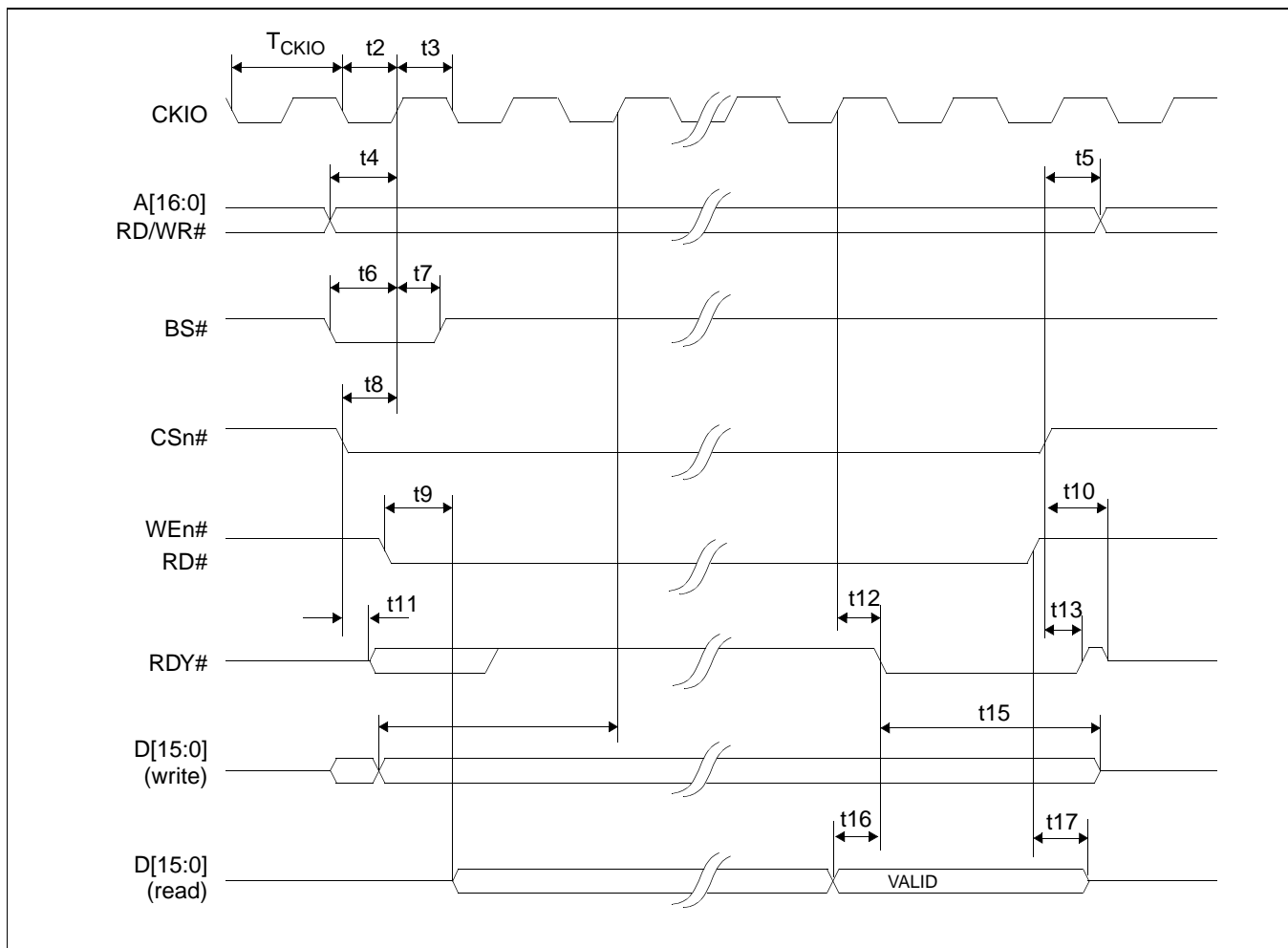

Figure 7-1: SH-4 Timing

#### Note

The SH-4 Wait State Control Register for the area in which the SED1375 resides must be set to a non-zero value. The SH-4 read-to-write cycle transition must be set to a non-zero value (with reference to BUSCLK).

Table 7-1: SH-4 Timing

Symbol	Parameter	Min	Max	Units
$f_{CKIO}$	Bus Clock frequency	0	50	MHz
$T_{CKIO}$	Bus Clock period	$1/f_{CKIO}$		
t2	Bus Clock pulse width low	8		ns
t3	Bus Clock pulse width high	8		ns
t4	A[16:0], RD/WR# setup to CKIO	0		ns
t5	A[16:0], RD/WR# hold from CS#	0		ns
t6	BS# setup	5		ns
t7	BS# hold	5		ns
t8	CSn# setup	0		ns
t9	Falling edge RD# to DB[15:0] driven		25	ns
t10	Rising edge CSn# to RDY# high impedance		$T_{CKIO}$	
t11	Falling edge CSn# to RDY# driven		20	ns
t12	CKIO to RDY# low		20	ns
t13	Rising edge CSn# to RDY# high		16	ns
t14	DB[15:0] setup to 2 <sup>nd</sup> CKIO after BS# (write cycle)	0		ns
t15	DB[15:0] hold (write cycle)	0		ns
t16	DB[15:0] valid to RDY# falling edge setup time (read cycle)	0		ns
t17	Rising edge RD# to DB[15:0] high impedance (read cycle)		10	ns

**Note**

CKIO may be turned off (held low) between accesses - see Section 13.5, “Turning Off BCLK Between Accesses” on page 83

## 7.1.2 SH-3 Interface Timing

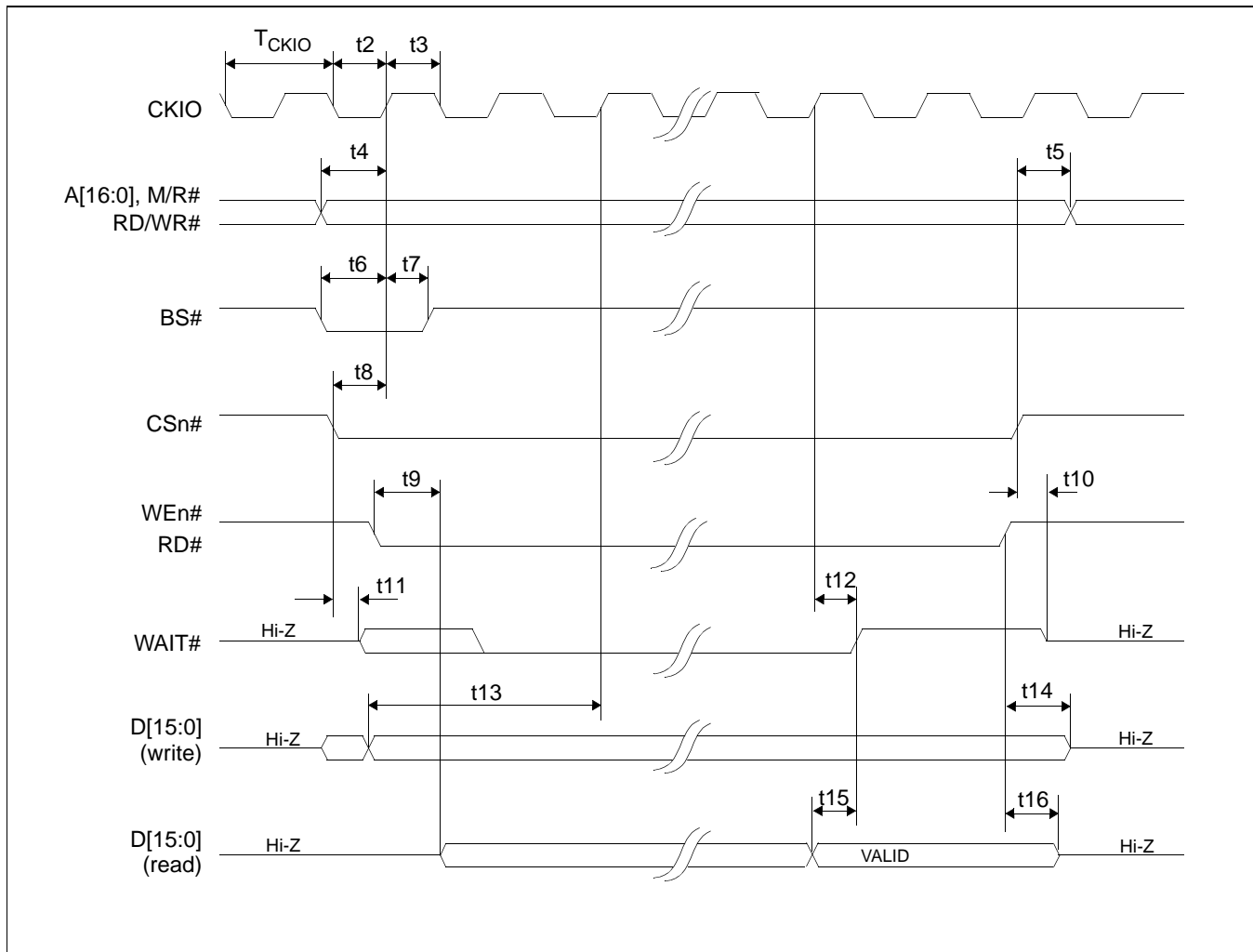

Figure 7-2: SH-3 Bus Timing

### Note

The SH-3 Wait State Control Register for the area in which the SED1375 resides must be set to a non-zero value.

Table 7-2: SH-3 Bus Timing

Symbol	Parameter	Min	Max <sup>a</sup>	Units
$f_{CKIO}$	Bus Clock frequency	0	50	MHz
$T_{CKIO}$	Bus Clock period	$1/f_{CKIO}$		
t2	Bus Clock pulse width low	8		ns
t3	Bus Clock pulse width high	8		ns
t4	A[16:0], RD/WR# setup to CKIO	0		ns
t5	A[16:0], RD/WR# hold from CS#	0		ns
t6	BS# setup	5		ns
t7	BS# hold	5		ns
t8	CSn# setup	0		ns
t9	Falling edge RD# to DB[15:0] driven		25	ns
t10	Rising edge CSn# to WAIT# high impedance		10	ns
t11	Falling edge CSn# to WAIT# driven		15	ns
t12	CKIO to WAIT# delay		20	ns
t13	DB[15:0] setup to 2 <sup>nd</sup> CKIO after BS# (write cycle)	0		ns
t14	DB[15:0] hold from rising edge of WEn# (write cycle)	0		ns
t15	DB[15:0] valid to WAIT# rising edge setup time (read cycle)	0		ns
t16	Rising edge RD# to DB[15:0] high impedance (read cycle)		10	ns

<sup>a</sup> One Software WAIT State Required

**Note**

CKIO may be turned off (held low) between accesses - see Section 13.5, “Turning Off BCLK Between Accesses” on page 83

### 7.1.3 Motorola MC68K #1 Interface Timing

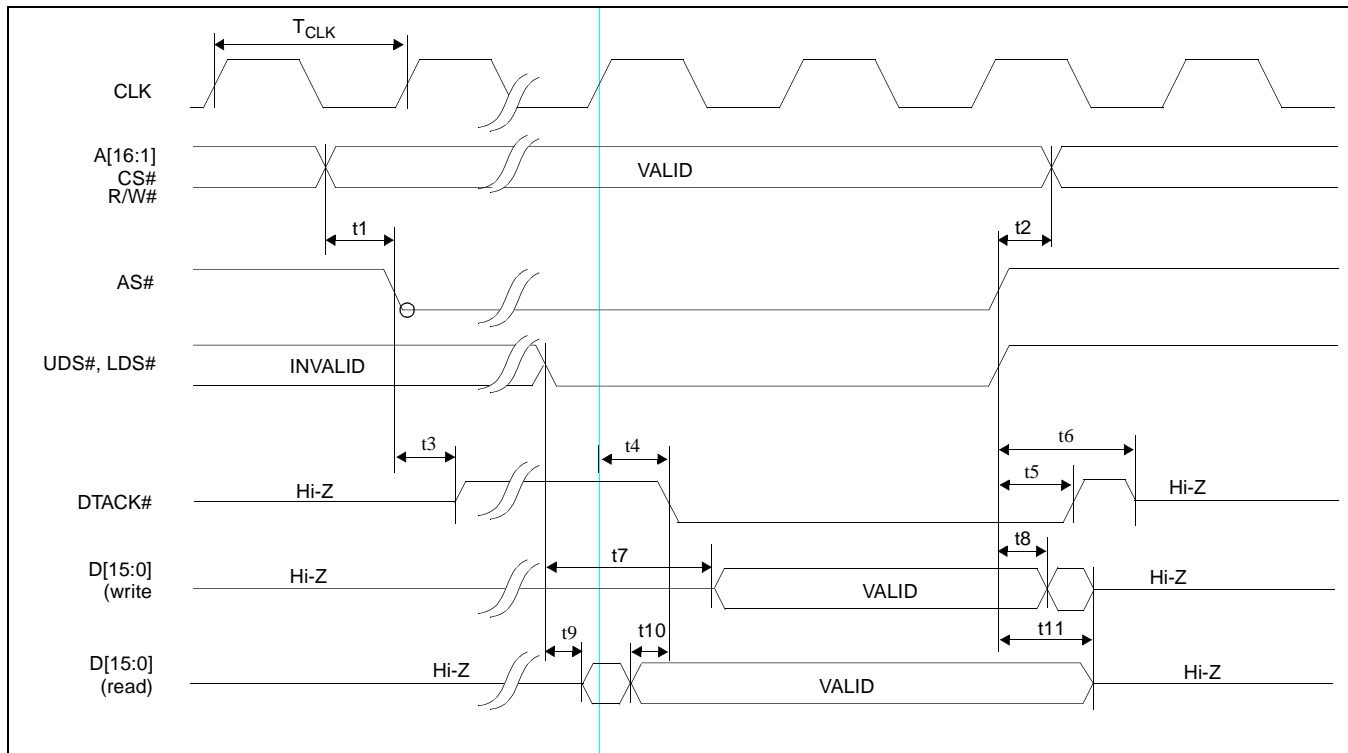

Figure 7-3: MC68K #1 Bus Timing (MC68000)

Table 7-3: MC68K #1 Bus Timing (MC68000)

Symbol	Parameter	Min	Max	Units
$f_{CLK}$	Bus Clock Frequency	0	33	MHz
$T_{CLK}$	Bus Clock period	$1/f_{CLK}$		
$t_1$	A[16:1], CS# valid before AS# falling edge	0		ns
$t_2$	A[16:1], CS# hold from AS# rising edge	0		ns
$t_3$	AS# low to DTACK# driven high		16	ns
$t_4$	CLK to DTACK# low		15	ns
$t_5$	AS# high to DTACK# high		20	ns
$t_6$	AS# high to DTACK# high impedance		$T_{CLK}$	
$t_7$	UDS#, LDS# falling edge to D[15:0] valid (write cycle)		$T_{CLK}$	
$t_8$	D[15:0] hold from AS# rising edge (write cycle)	0		ns
$t_9$	UDS#, LDS# falling edge to D[15:0] driven (read cycle)		15	ns
$t_{10}$	D[15:0] valid to DTACK# falling edge (read cycle)	0		ns
$t_{11}$	UDS#, LDS# rising edge to D[15:0] high impedance		10	ns

#### Note

CLK may be turned off (held low) between accesses - see Section 13.5, “Turning Off BCLK Between Accesses” on page 83

### 7.1.4 Motorola MC68K #2 Interface Timing

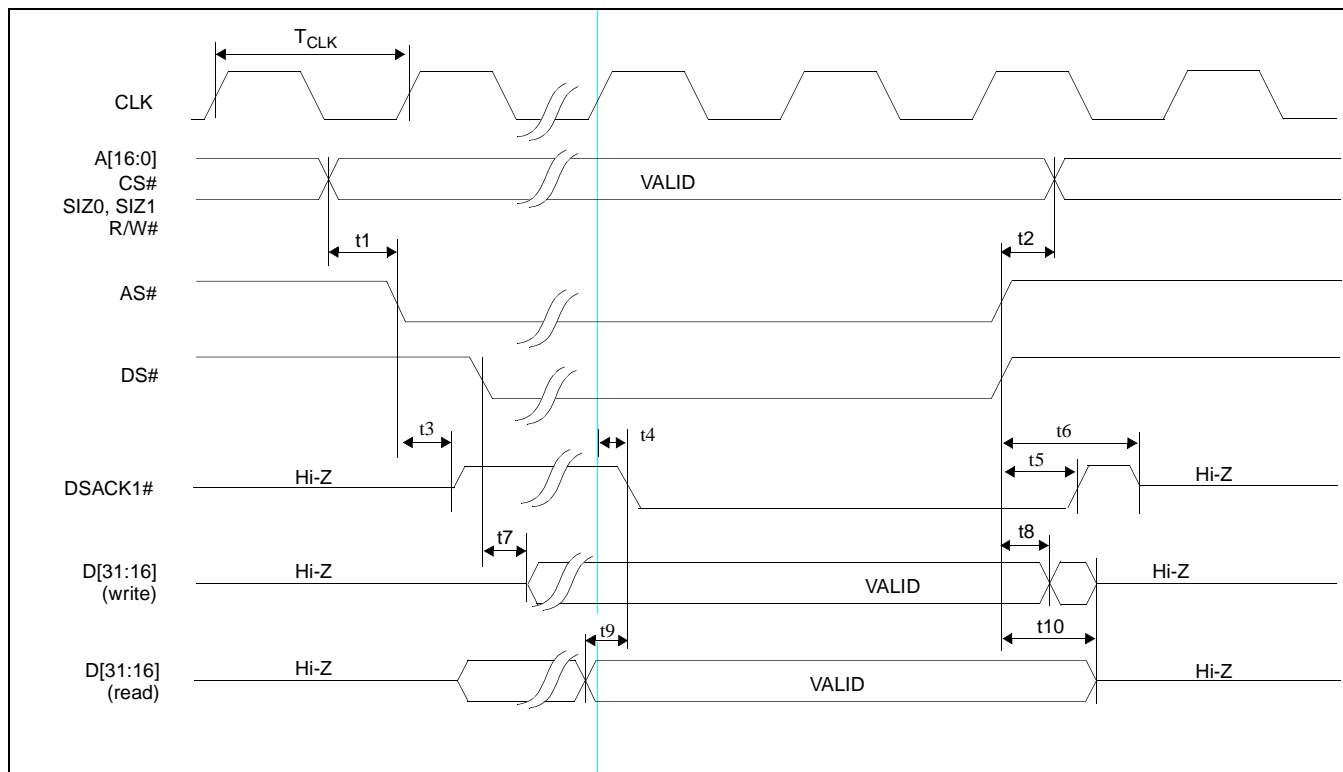

Figure 7-4: MC68K #2 Timing (MC68030)

Table 7-4: MC68K #2 Timing (MC68030)

Symbol	Parameter	Min	Max	Units
$f_{CLK}$	Bus Clock frequency	0	33	MHz
$T_{CLK}$	Bus Clock period	$1/f_{CLK}$		
$t_1$	A[16:0], CS#, SIZ0, SIZ1 valid before AS# falling edge	0		ns
$t_2$	A[16:0], CS#, SIZ0, SIZ1 hold from AS#, DS# rising edge	0		ns
$t_3$	AS# low to DSACK1# driven high		22	ns
$t_4$	CLK to DSACK1# low		18	ns
$t_5$	AS# high to DSACK1# high		20	ns
$t_6$	AS# high to DSACK1# high impedance		$T_{CLK}$	
$t_7$	DS# falling edge to D[31:16] valid (write cycle)		$T_{CLK}/2$	
$t_8$	AS#, DS# rising edge to D[31:16] invalid (write cycle)	0		ns
$t_9$	D[31:16] valid to DSACK1# low (read cycle)	0		ns
$t_{10}$	AS#, DS# rising edge to D[31:16] high impedance		20	ns

**Note**

CLK may be turned off (held low) between accesses - see Section 13.5, “Turning Off BCLK Between Accesses” on page 83

## 7.1.5 Generic #1 Interface Timing

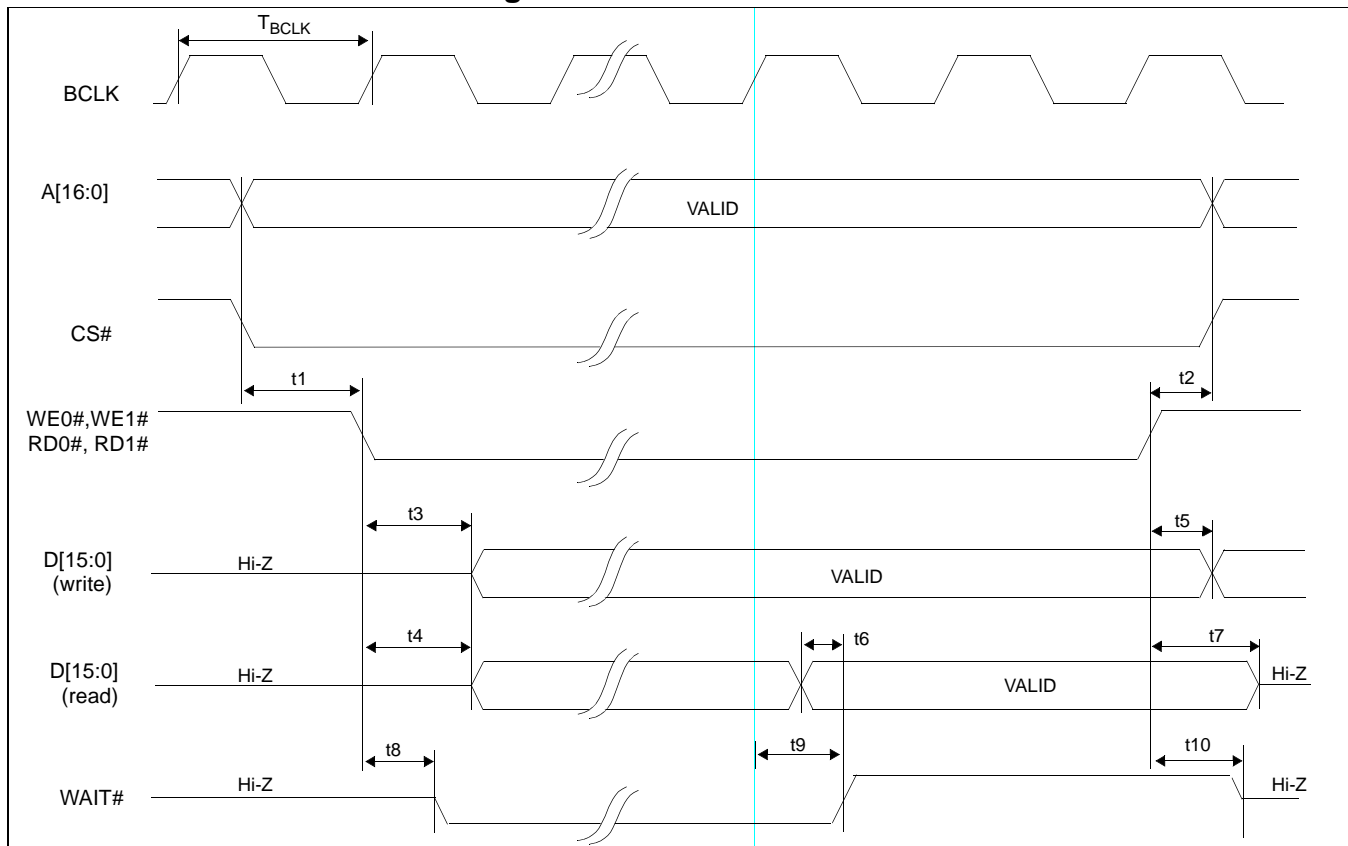

Figure 7-5: Generic #1 Timing

Table 7-5: Generic #1 Timing

Symbol	Parameter	Min	Max	Units
$f_{BCLK}$	Bus Clock frequency	0	50	MHz
$T_{BCLK}$	Bus Clock period	$1/f_{BCLK}$		MHz
$t_1$	A[16:0], CS# valid to WE0#, WE1# low (write cycle) or RD0#, RD1# low (read cycle)	0		ns
$t_2$	WE0#, WE1# high (write cycle) or RD0#, RD1# high (read cycle) to A[16:0], CS# invalid	0		ns
$t_3$	WE0#, WE1# low to D[15:0] valid (write cycle)		$T_{BCLK}$	
$t_4$	RD0#, RD1# low to D[15:0] driven (read cycle)		17	ns
$t_5$	WE0#, WE1# high to D[15:0] invalid (write cycle)	0		ns
$t_6$	D[15:0] valid to WAIT# high (read cycle)	0		ns
$t_7$	RD0#, RD1# high to D[15:0] high impedance (read cycle)		10	ns
$t_8$	WE0#, WE1# low (write cycle) or RD0#, RD1# low (read cycle) to WAIT# driven low		16	ns
$t_9$	BCLK to WAIT# high		16	ns
$t_{10}$	WE0#, WE1# high (write cycle) or RD0#, RD1# high (read cycle) to WAIT# high impedance		16	ns

### Note

BCLK may be turned off (held low) between accesses - see Section 13.5, “Turning Off BCLK Between Accesses” on page 83



### 7.1.6 Generic #2 Interface Timing

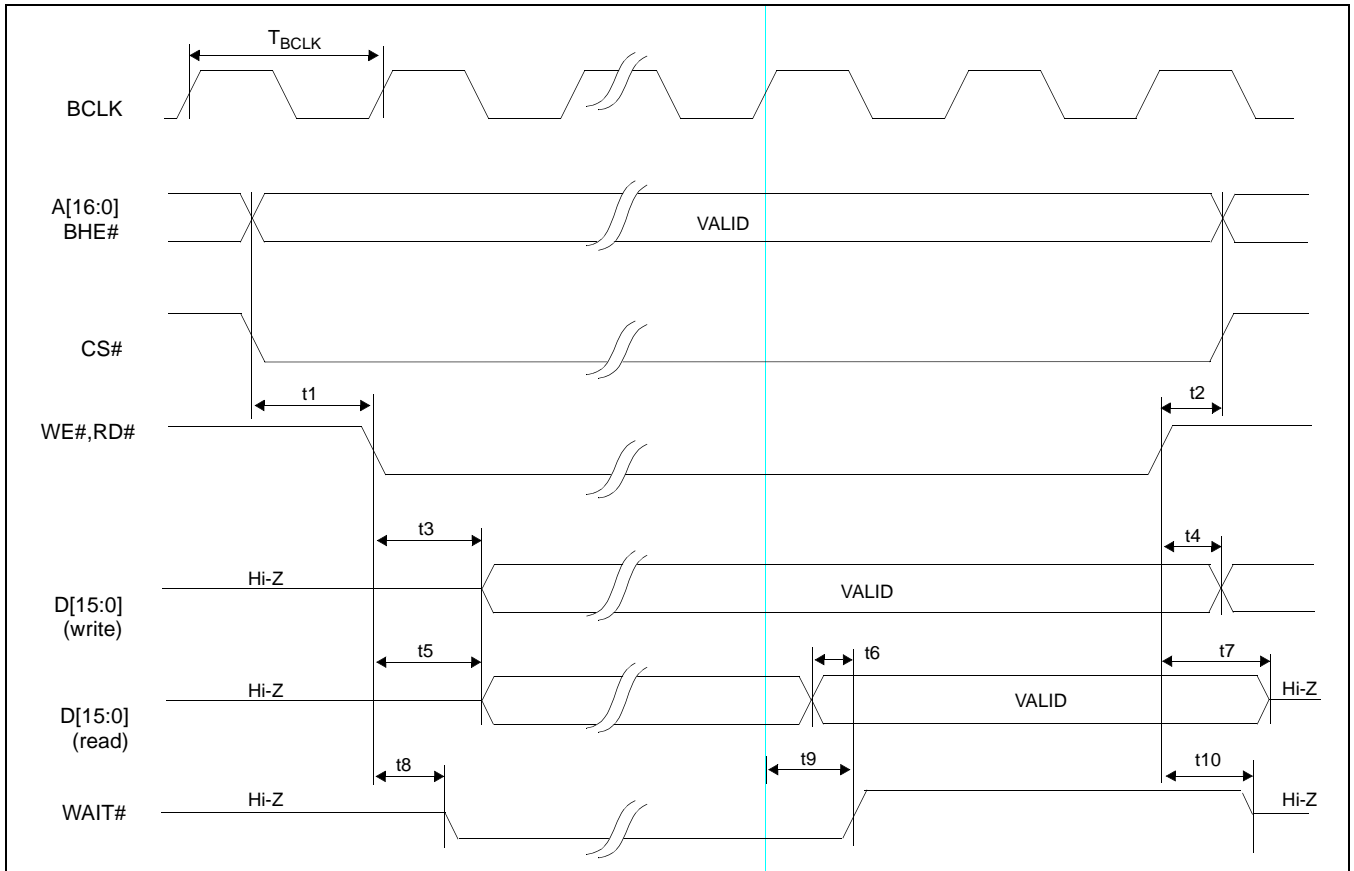

Figure 7-6: Generic #2 Timing

Table 7-6: Generic #2 Timing

Symbol	Parameter	Min	Max	Units
$f_{BCLK}$	Bus Clock frequency	0	50	MHz
$T_{BCLK}$	Bus Clock period	$1/f_{BCLK}$		
$t_1$	A[16:0], BHE#, CS# valid to WE#, RD# low	0		ns
$t_2$	WE#, RD# high to A[16:0], BHE#, CS# invalid	0		ns
$t_3$	WE# low to D[15:0] valid (write cycle)		$T_{BCLK}$	
$t_4$	WE# high to D[15:0] invalid (write cycle)	0		ns
$t_5$	RD# low to D[15:0] driven (read cycle)		16	ns
$t_6$	D[15:0] valid to WAIT# high (read cycle)	0		ns
$t_7$	RD# high to D[15:0] high impedance (read cycle)		10	ns
$t_8$	WE#, RD# low to WAIT# driven low		14	ns
$t_9$	BCLK to WAIT# high		10	ns
$t_{10}$	WE#, RD# high to WAIT# high impedance		11	ns

**Note**

BCLK may be turned off (held low) between accesses - see Section 13.5, “Turning Off BCLK Between Accesses” on page 83

## 7.2 Clock Input Requirements

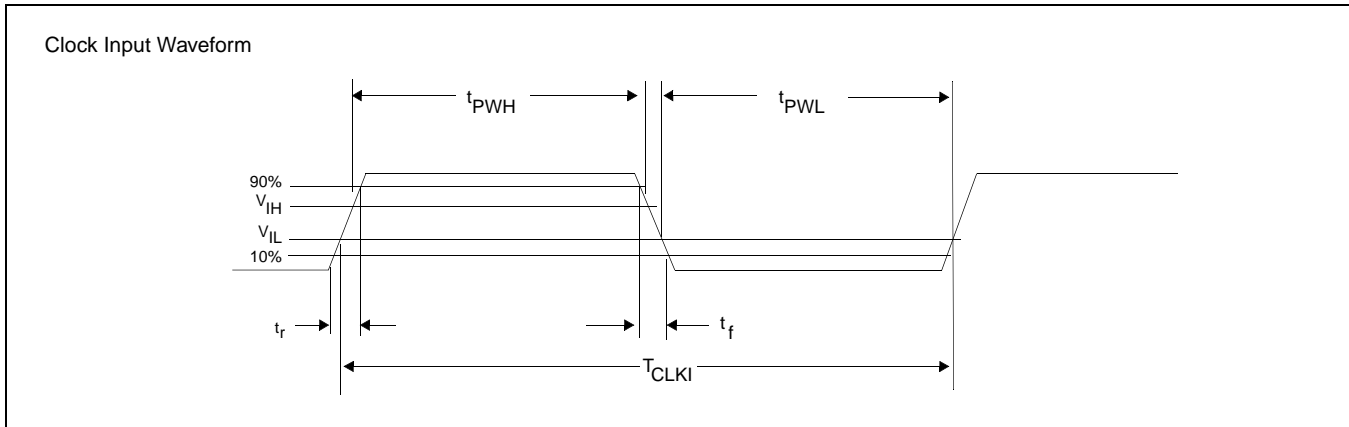

Figure 7-7: Clock Input Requirements

Table 7-7: Clock Input Requirements

Symbol	Parameter	Min	Max	Units
$f_{CLKI}$	Input Clock Frequency (CLKI)	0	50	MHz
$T_{CLKI}$	Input Clock period (CLKI)	$1/f_{CLKI}$		
$t_{PWH}$	Input Clock Pulse Width High (CLKI)	8		ns
$t_{PWL}$	Input Clock Pulse Width Low (CLKI)	8		ns
$t_f$	Input Clock Fall Time (10% - 90%)		5	ns
$t_r$	Input Clock Rise Time (10% - 90%)		5	ns

### Note

When CLKI is > 25MHz it must be divided by 2 (REG[02h] bit 4 = 1).

## 7.3 Display Interface

### 7.3.1 Power On/Reset Timing

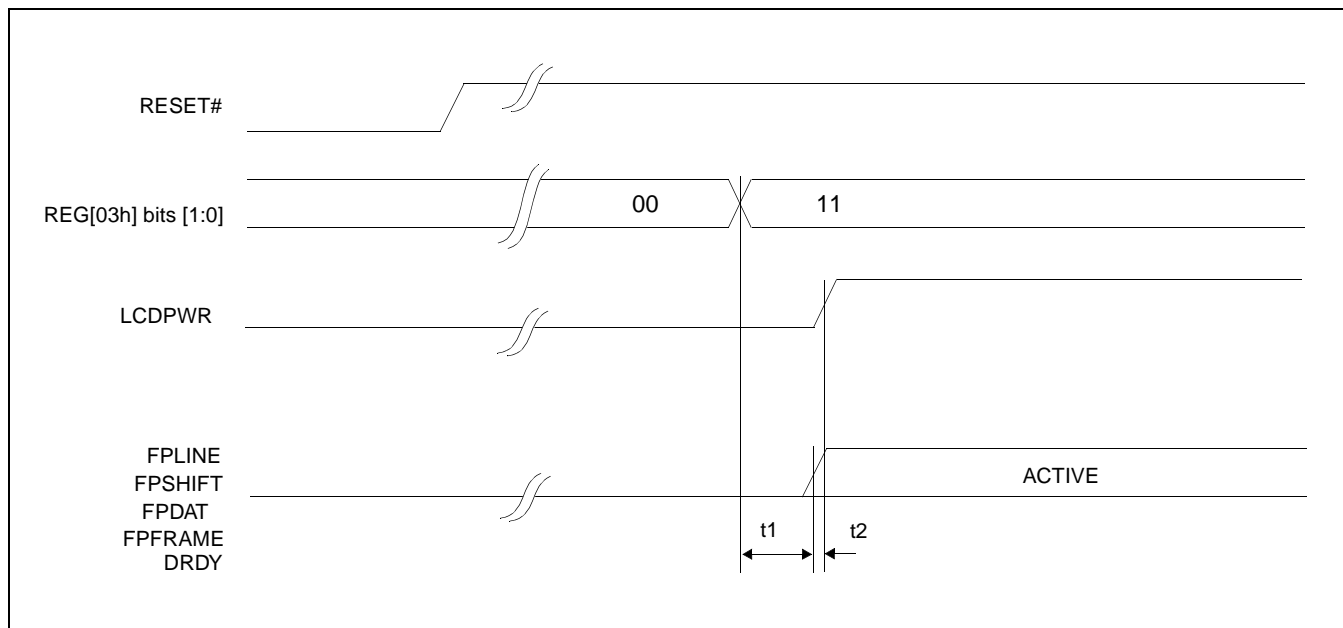

Figure 7-8: LCD Panel Power On/Reset Timing

Table 7-8: LCD Panel Power On/Reset Timing

Symbol	Parameter	Min	Typ	Max	Units
t1	REG[03h] to FPLINE, FPFFRAME, FPSHIFT, FPDAT, DRDY active			$T_{FPFRAME}$	ns
t2	FPLINE, FPFFRAME, FPSHIFT, FPDAT, DRDY active to LCDPWR		0		Frames

**Note**

Where  $T_{FPFRAME}$  is the period of FPFFRAME and  $T_{PCLK}$  is the period of the pixel clock.

## 7.3.2 Power Down/Up Timing

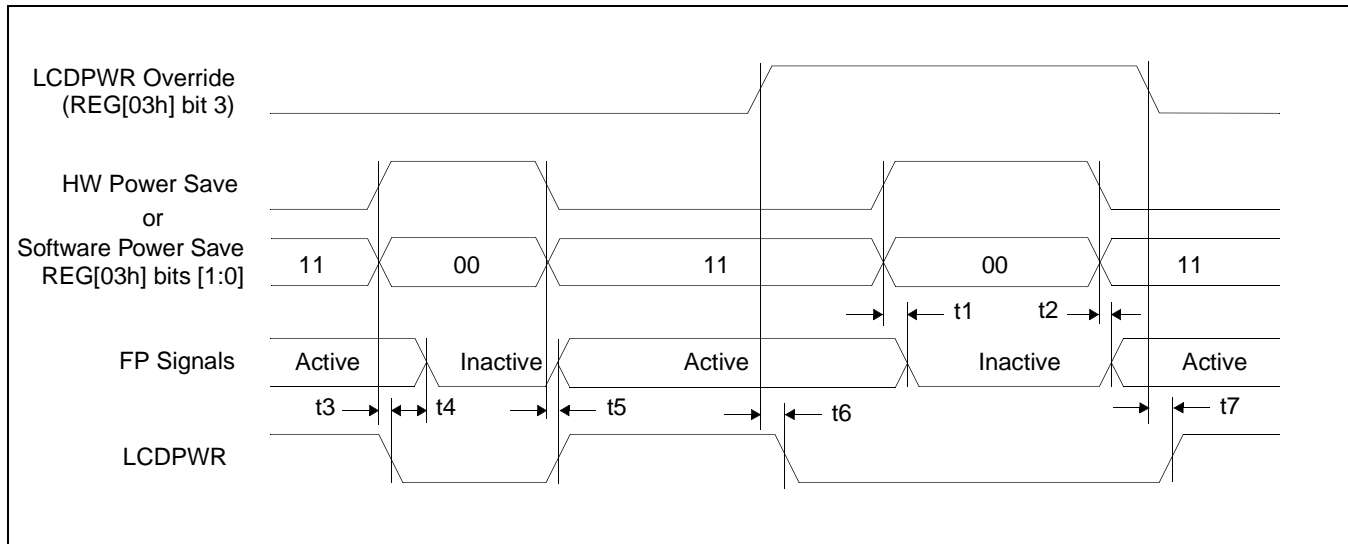

Figure 7-9: Power Down/Up Timing

Table 7-9: Power Down/Up Timing

Symbol	Parameter	Min	Typ	Max	Units
t1	HW Power Save active to FPLINE, FPFRAME, FPSHIFT, FPDAT, DRDY inactive - LCDPWR Override = 1			1	Frame
t2	HW Power Save inactive to FPLINE, FPFRAME, FPSHIFT, FPDAT, DRDY active - LCDPWR Override = 1			1	Frame
t3	HW Power Save active to FPLINE, FPFRAME, FPSHIFT, FPDAT, DRDY inactive - LCDPWR Override = 0			1	Frame
t4	LCDPWR low to FPLINE, FPFRAME, FPSHIFT, FPDAT, DRDY inactive - LCDPWR Override = 0		127		Frame
t5	HW Power Save inactive to FPLINE, FPFRAME, FPSHIFT, FPDAT, DRDY, LCDPWR active - LCDPWR Override = 0		0		Frame
t6	LCDPWR Override active (1) to LCDPWR inactive			1	Frame
t7	LCDPWR Override inactive (1) to LCDPWR active			1	Frame

### 7.3.3 Single Monochrome 4-Bit Panel Timing

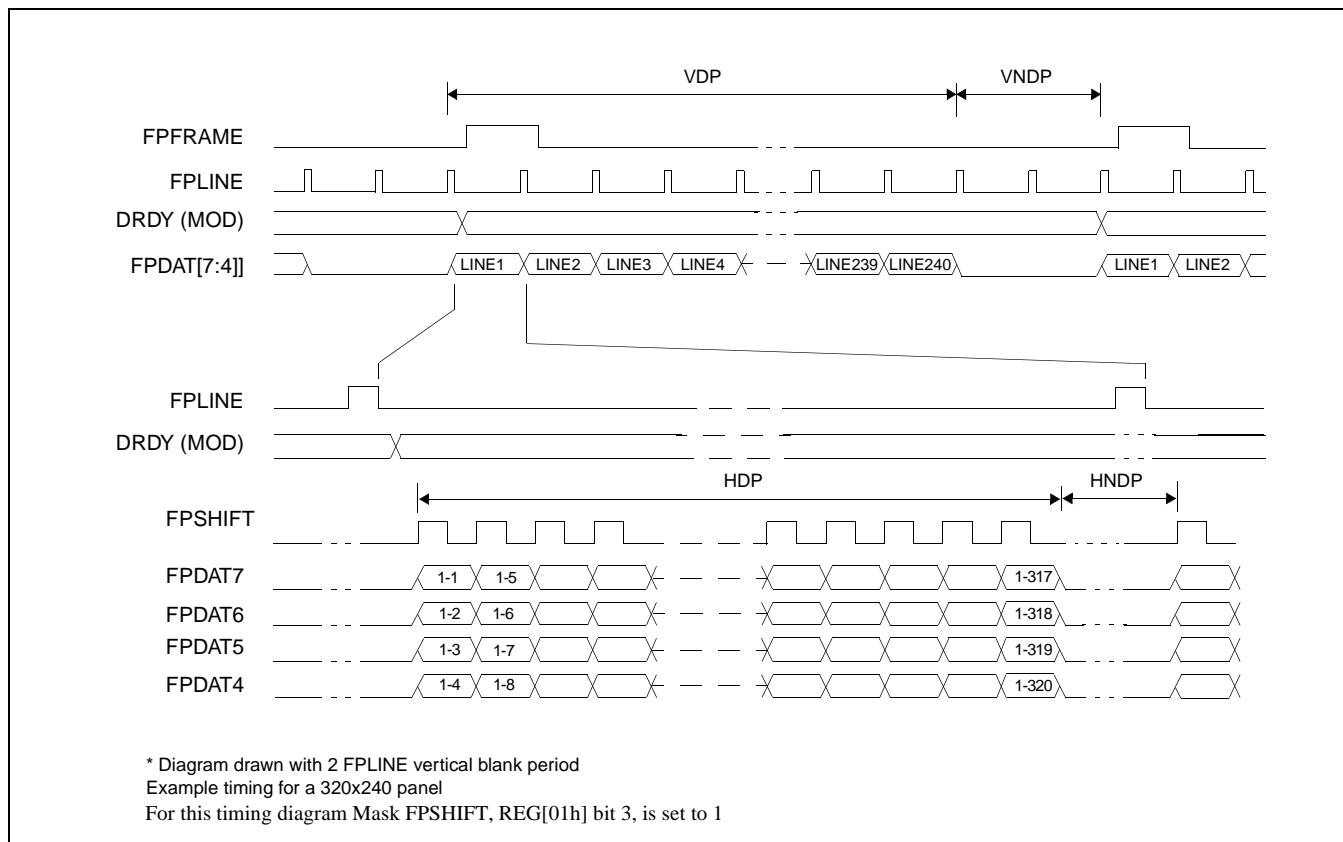

Figure 7-10: Single Monochrome 4-Bit Panel Timing

- |        |                               |  |
|--------|-------------------------------|--|
| VDP =  | Vertical Display Period       | = (REG[06h] bits 1-0, REG[05h] bits 7-0) + 1 Lines |
| VNDP = | Vertical Non-Display Period   | = REG[0Ah] bits 5-0 Lines                          |
| HDP =  | Horizontal Display Period     | = ((REG[04h] bits 6-0) + 1) x 8Ts                  |
| HNDP = | Horizontal Non-Display Period | = (REG[08h] + 4) x 8Ts                             |

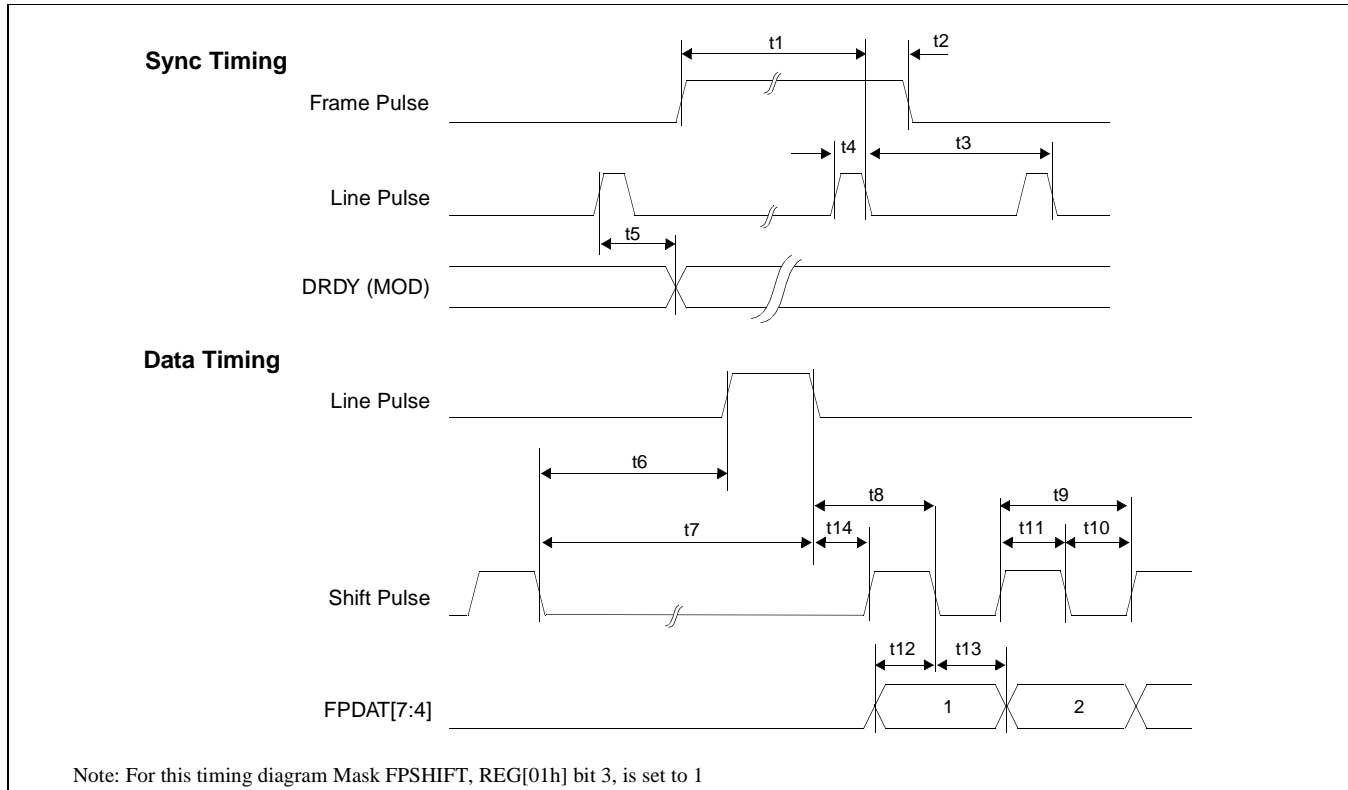

Figure 7-11: Single Monochrome 4-Bit Panel A.C. Timing

Table 7-10: Single Monochrome 4-Bit Panel A.C. Timing

Symbol	Parameter	Min	Typ	Max	Units
t1	Frame Pulse setup to Line Pulse falling edge	note 2			(note 1)
t2	Frame Pulse hold from Line Pulse falling edge	9			Ts
t3	Line Pulse period	note 3			
t4	Line Pulse pulse width	9			Ts
t5	MOD delay from Line Pulse rising edge	1			Ts
t6	Shift Pulse falling edge to Line Pulse rising edge	note 4			
t7	Shift Pulse falling edge to Line Pulse falling edge	note 5			
t8	Line Pulse falling edge to Shift Pulse falling edge	t14 + 2			Ts
t9	Shift Pulse period	4			Ts
t10	Shift Pulse pulse width low	2			Ts
t11	Shift Pulse pulse width high	2			Ts
t12	FPDAT[7:4] setup to Shift Pulse falling edge	2			Ts
t13	FPDAT[7:4] hold to Shift Pulse falling edge	2			Ts
t14	Line Pulse falling edge to Shift Pulse rising edge	23			Ts

- Ts = pixel clock period
- $t1_{min} = t3_{min} - 9Ts$
- $t3_{min} = [((REG[04h] \text{ bits } 6-0)+1) \times 8 + ((REG[08h] \text{ bits } 4-0) + 4) \times 8]Ts$
- $t6_{min} = [(REG[08h] \text{ bits } 4-0) \times 8 + 2]Ts$
- $t7_{min} = [(REG[08h] \text{ bits } 4-0) \times 8 + 11]Ts$

### 7.3.4 Single Monochrome 8-Bit Panel Timing

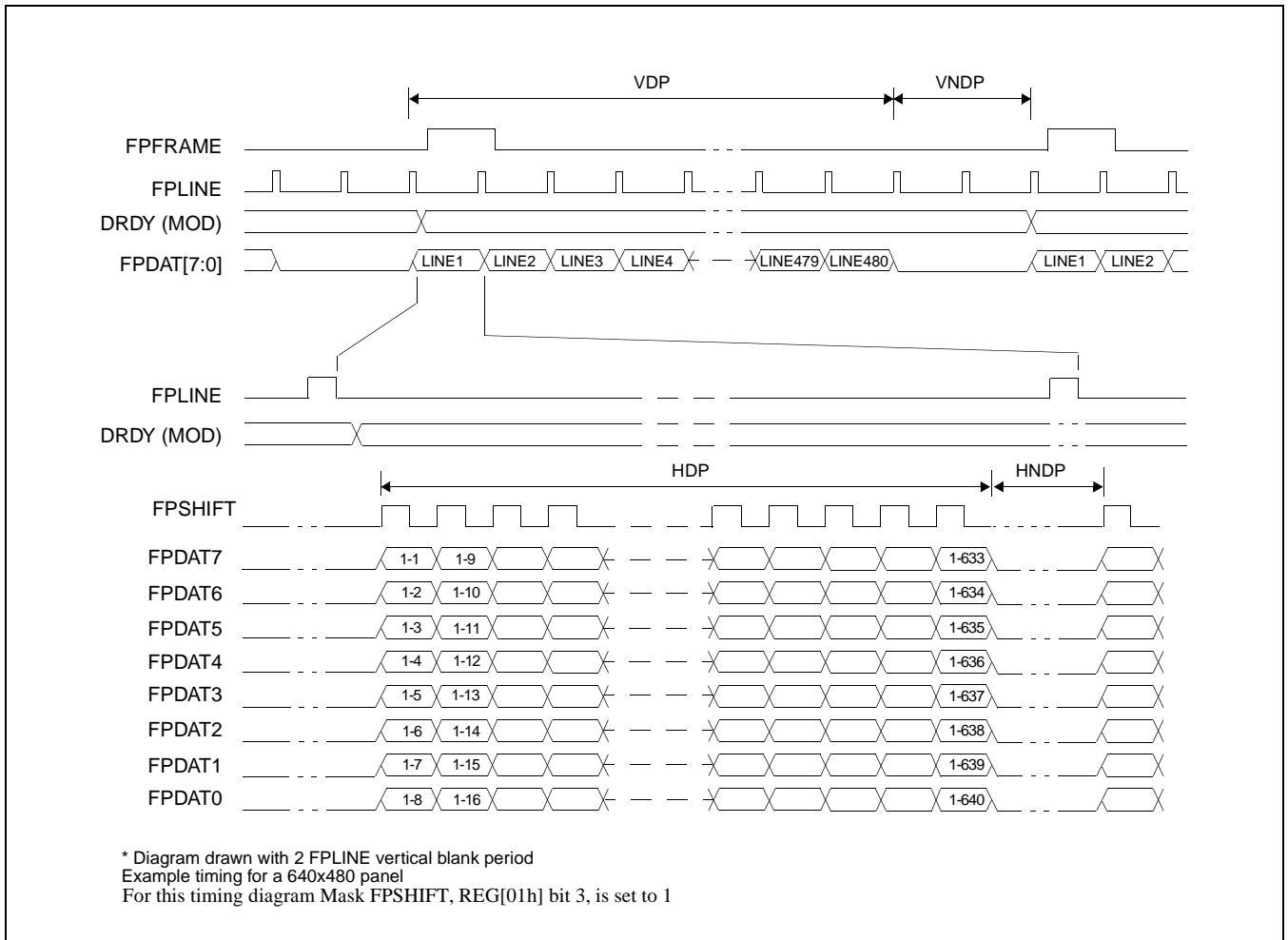

Figure 7-12: Single Monochrome 8-Bit Panel Timing

- |        |                               |  |
|--------|-------------------------------|--|
| VDP =  | Vertical Display Period       | = (REG[06h] bits 1-0, REG[05h] bits 7-0) + 1 Lines |
| VNDP = | Vertical Non-Display Period   | = REG[0Ah] bits 5-0 Lines                          |
| HDP =  | Horizontal Display Period     | = ((REG[04h] bits 6-0) + 1) x 8Ts                  |
| HNDP = | Horizontal Non-Display Period | = (REG[08h] + 4) x 8Ts                             |

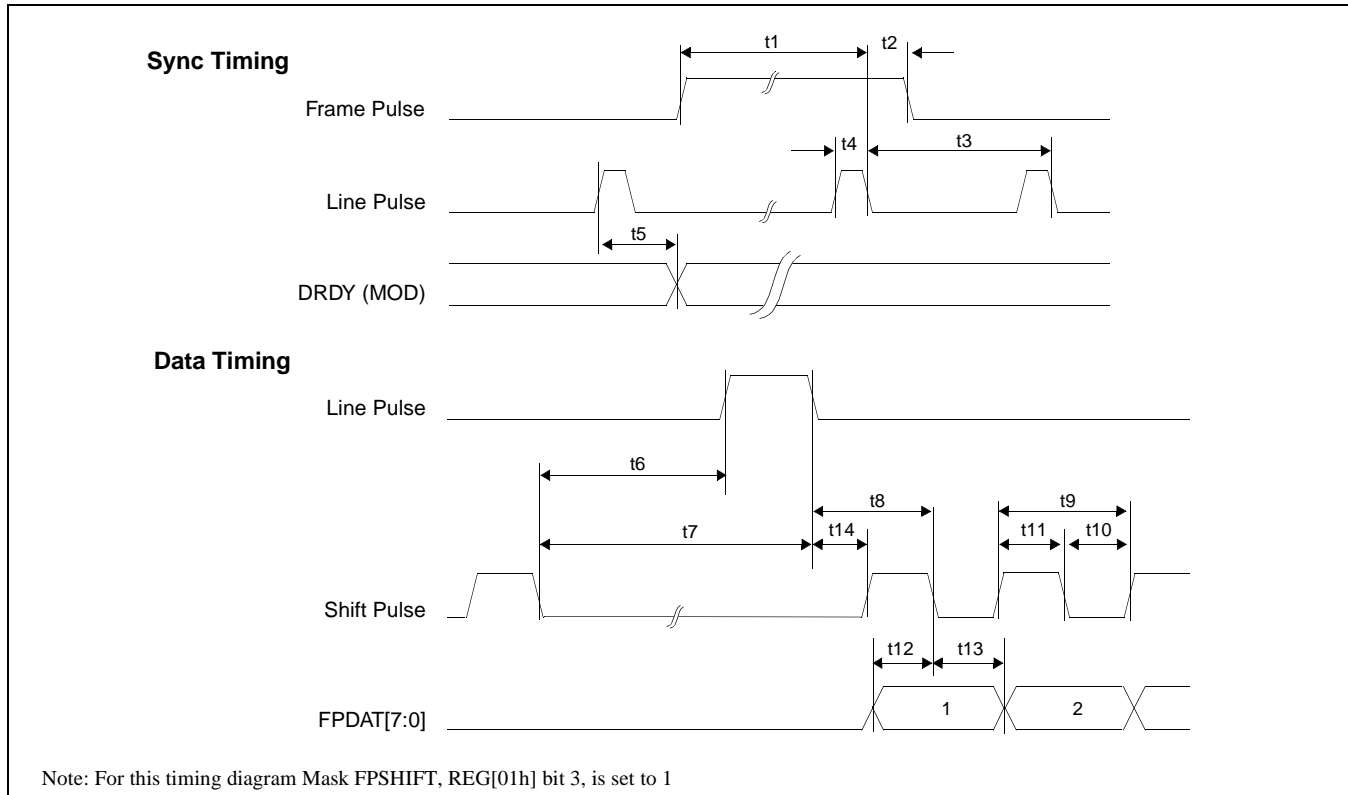

Figure 7-13: Single Monochrome 8-Bit Panel A.C. Timing

Table 7-11: Single Monochrome 8-Bit Panel A.C. Timing

Symbol	Parameter	Min	Typ	Max	Units
t1	Frame Pulse setup to Line Pulse falling edge	note 2			(note 1)
t2	Frame Pulse hold from Line Pulse falling edge	9			Ts
t3	Line Pulse period	note 3			
t4	Line Pulse pulse width	9			Ts
t5	MOD delay from Line Pulse rising edge	1			Ts
t6	Shift Pulse falling edge to Line Pulse rising edge	note 4			
t7	Shift Pulse falling edge to Line Pulse falling edge	note 5			
t8	Line Pulse falling edge to Shift Pulse falling edge	t14 + 4			Ts
t9	Shift Pulse period	8			Ts
t10	Shift Pulse pulse width low	4			Ts
t11	Shift Pulse pulse width high	4			Ts
t12	FPDAT[7:0] setup to Shift Pulse falling edge	4			Ts
t13	FPDAT[7:0] hold to Shift Pulse falling edge	4			Ts
t14	Line Pulse falling edge to Shift Pulse rising edge	23			Ts

1. Ts = pixel clock period
2.  $t1_{min} = t3_{min} - 9Ts$
3.  $t3_{min} = [((REG[04h] \text{ bits } 6-0)+1) \times 8 + ((REG[08h] \text{ bits } 4-0) + 4) \times 8]Ts$
4.  $t6_{min} = [(REG[08h] \text{ bits } 4-0) \times 8 + 4]Ts$
5.  $t7_{min} = [(REG[08h] \text{ bits } 4-0) \times 8 + 13]Ts$



### 7.3.5 Single Color 4-Bit Panel Timing

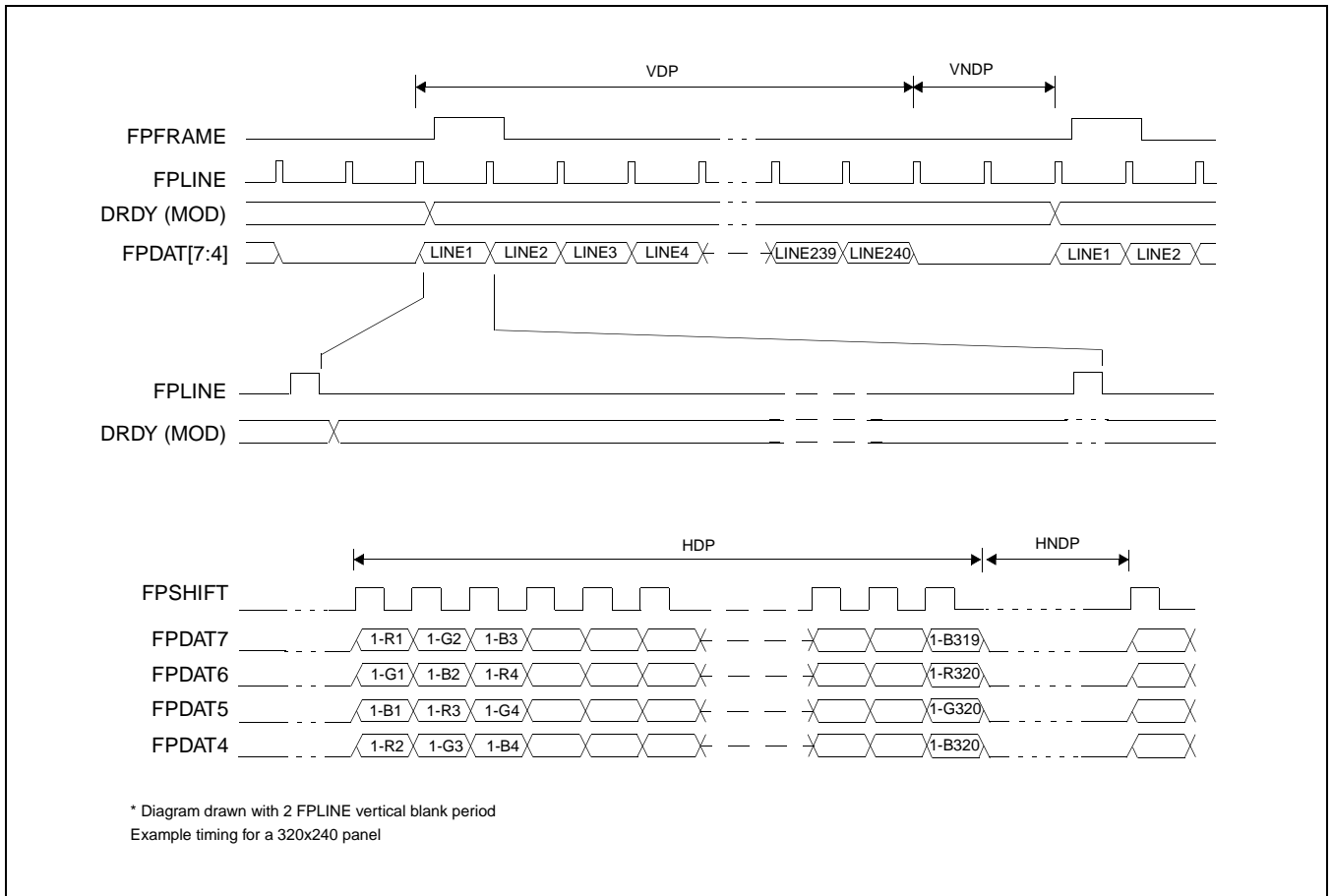

Figure 7-14: Single Color 4-Bit Panel Timing

- |        |                               |  |
|--------|-------------------------------|--|
| VDP =  | Vertical Display Period       | = (REG[06h] bits 1-0, REG[05h] bits 7-0) + 1 Lines |
| VNDP = | Vertical Non-Display Period   | = REG[0Ah] bits 5-0 Lines                          |
| HDP =  | Horizontal Display Period     | = ((REG[04h] bits 6-0) + 1) x 8Ts                  |
| HNBP = | Horizontal Non-Display Period | = (REG[08h] + 4) x 8Ts                             |

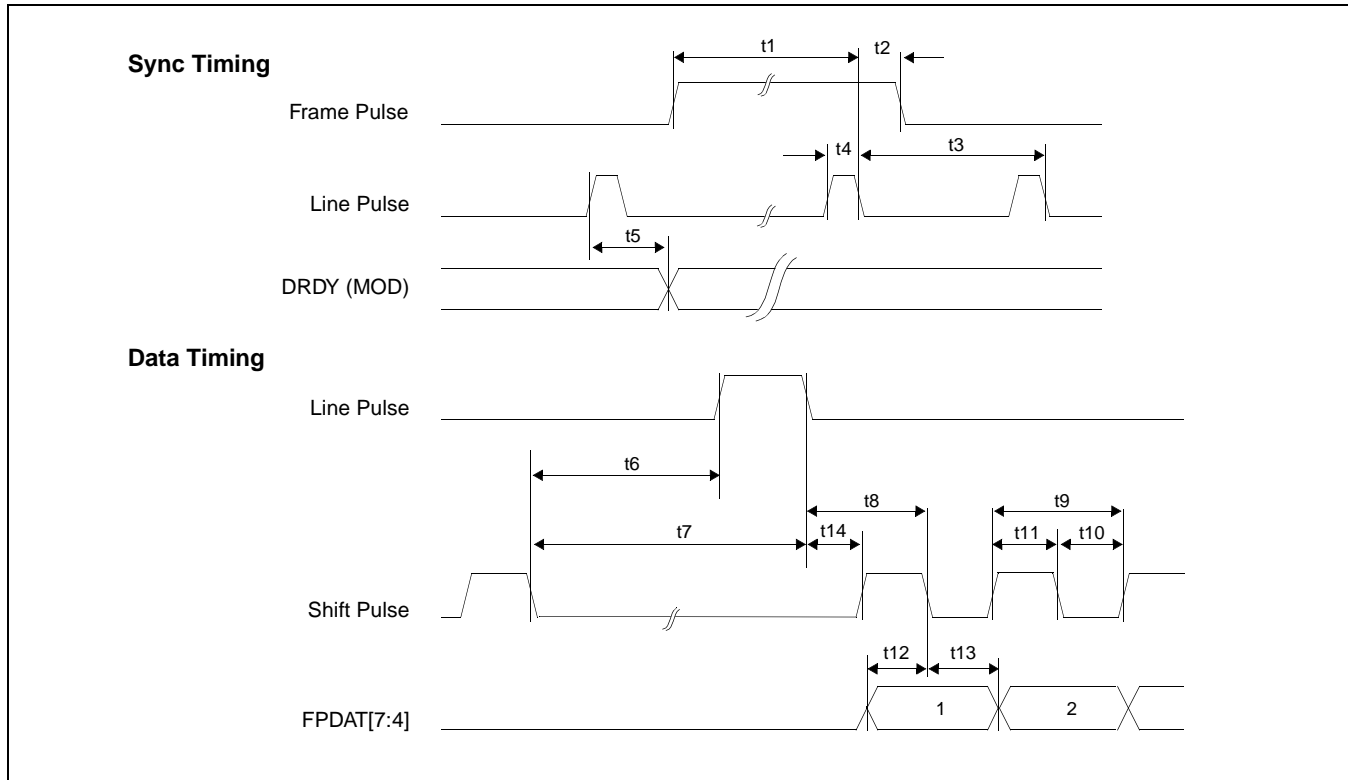

Figure 7-15: Single Color 4-Bit Panel A.C. Timing

Table 7-12: Single Color 4-Bit Panel A.C. Timing

Symbol	Parameter	Min	Typ	Max	Units
t1	Frame Pulse setup to Line Pulse falling edge	note 2			(note 1)
t2	Frame Pulse hold from Line Pulse falling edge	9			Ts
t3	Line Pulse period	note 3			
t4	Line Pulse pulse width	9			Ts
t5	MOD delay from Line Pulse rising edge	1			Ts
t6	Shift Pulse falling edge to Line Pulse rising edge	note 4			
t7	Shift Pulse falling edge to Line Pulse falling edge	note 5			
t8	Line Pulse falling edge to Shift Pulse falling edge	t14 + 0.5			Ts
t9	Shift Pulse period	1			Ts
t10	Shift Pulse pulse width low	0.5			Ts
t11	Shift Pulse pulse width high	0.5			Ts
t12	FPDAT[7:4] setup to Shift Pulse falling edge	0.5			Ts
t13	FPDAT[7:4] hold to Shift Pulse falling edge	0.5			Ts
t14	Line Pulse falling edge to Shift Pulse rising edge	23			Ts

1. Ts = pixel clock period
2.  $t1_{min} = t3_{min} - 9Ts$
3.  $t3_{min} = [((REG[04h] \text{ bits } 6-0) + 1) \times 8 + ((REG[08h] \text{ bits } 4-0) + 4) \times 8]Ts$
4.  $t6_{min} = [(REG[08h] \text{ bits } 4-0) \times 8 + 0.5]Ts$
5.  $t7_{min} = [(REG[08h] \text{ bits } 4-0) \times 8 + 9.5]Ts$

### 7.3.6 Single Color 8-Bit Panel Timing (Format 1)

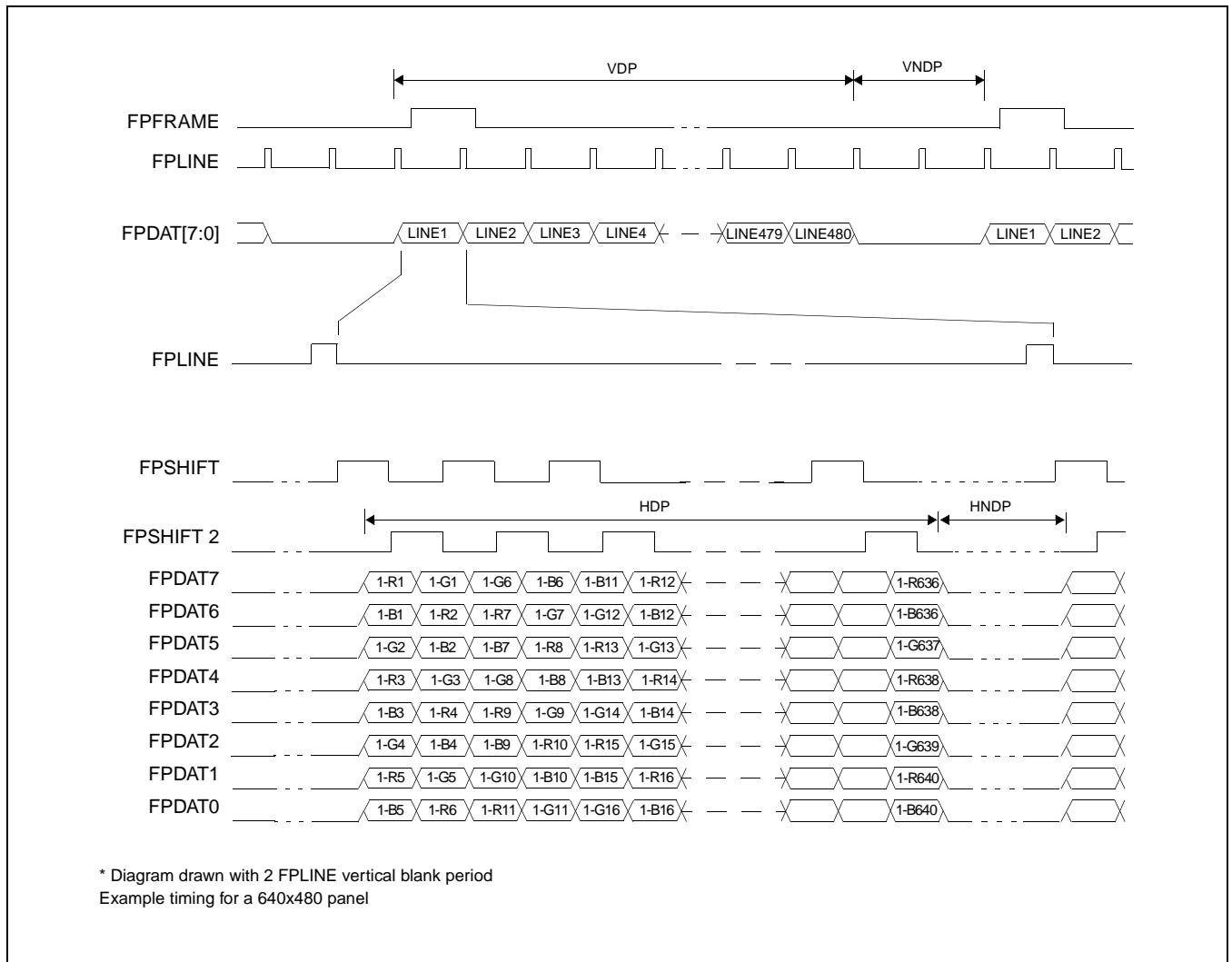

Figure 7-16: Single Color 8-Bit Panel Timing (Format 1)

- |        |                               |  |
|--------|-------------------------------|--|
| VDP =  | Vertical Display Period       | = (REG[06h] bits 1-0, REG[05h] bits 7-0) + 1 Lines |
| VNDP = | Vertical Non-Display Period   | = REG[0Ah] bits 5-0 Lines                          |
| HDP =  | Horizontal Display Period     | = ((REG[04h] bits 6-0) + 1) x 8Ts                  |
| HNDP = | Horizontal Non-Display Period | = (REG[08h] + 4) x 8Ts                             |

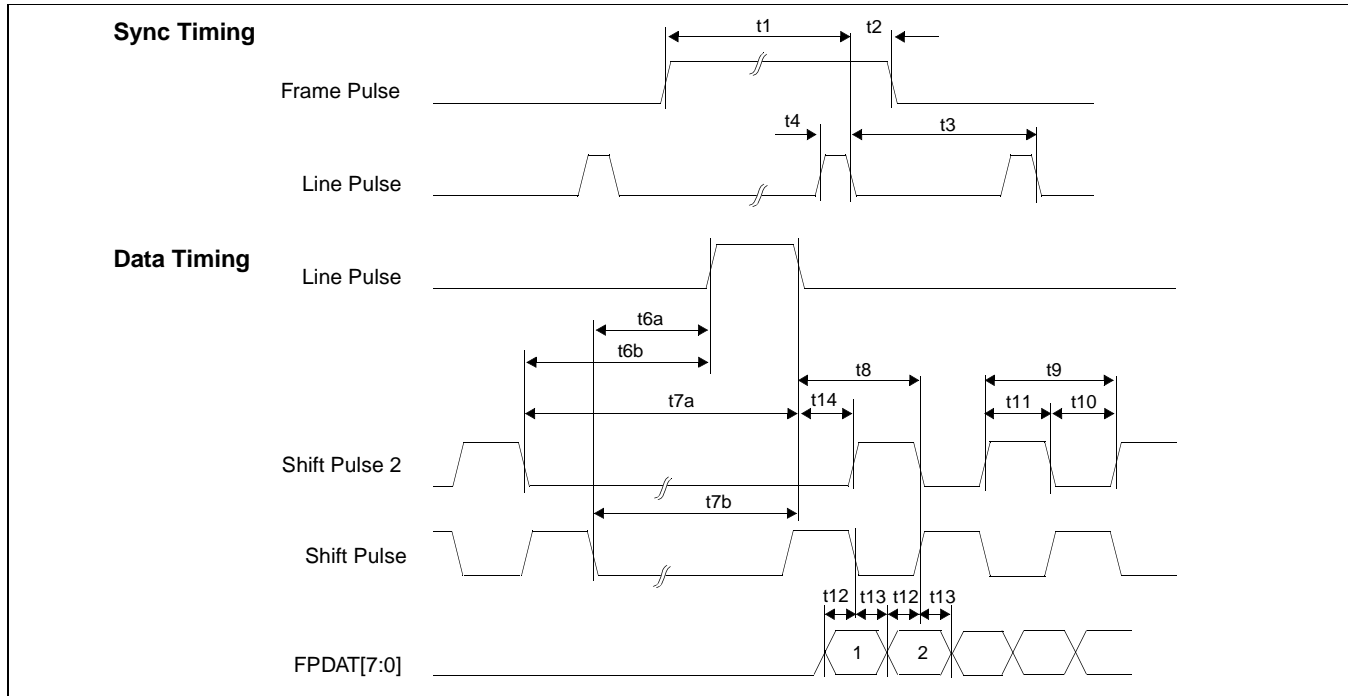

Figure 7-17: Single Color 8-Bit Panel A.C. Timing (Format 1)

Table 7-13: Single Color 8-Bit Panel A.C. Timing (Format 1)

Symbol	Parameter	Min	Typ	Max	Units
t1	Frame Pulse setup to Line Pulse falling edge	note 2			(note 1)
t2	Frame Pulse hold from Line Pulse falling edge	9			Ts
t3	Line Pulse period	note 3			
t4	Line Pulse pulse width	9			Ts
t6a	Shift Pulse falling edge to Line Pulse rising edge	note 4			
t6b	Shift Pulse 2 falling edge to Line Pulse rising edge	note 5			
t7a	Shift Pulse 2 falling edge to Line Pulse falling edge	note 6			
t7b	Shift Pulse falling edge to Line Pulse falling edge	note 7			
t8	Line Pulse falling edge to Shift Pulse rising, Shift Pulse 2 falling edge	t14 + 2			Ts
t9	Shift Pulse 2, Shift Pulse period	4			Ts
t10	Shift Pulse 2, Shift Pulse pulse width low	2			Ts
t11	Shift Pulse 2, Shift Pulse pulse width high	2			Ts
t12	FPDAT[7:0] setup to Shift Pulse 2, Shift Pulse falling edge	1			Ts
t13	FPDAT[7:0] hold from Shift Pulse 2, Shift Pulse falling edge	1			Ts
t14	Line Pulse falling edge to Shift Pulse rising edge	23			Ts

1. Ts = pixel clock period
2.  $t1_{min} = t3_{min} - 9Ts$
3.  $t3_{min} = [((REG[04h] \text{ bits } 6-0)+1) \times 8 + ((REG[08h] \text{ bits } 4-0) + 4) \times 8]Ts$
4.  $t6a_{min} = [(REG[08h] \text{ bits } 4-0) \times 8 + t13 - t10]Ts$
5.  $t6b_{min} = [(REG[08h] \text{ bits } 4-0) \times 8 + t13]Ts$
6.  $t7a_{min} = [(REG[08h] \text{ bits } 4-0) \times 8 + 11]Ts$
7.  $t7b_{min} = [(REG[08h] \text{ bits } 4-0) \times 8 + 11] - t10]Ts$

### 7.3.7 Single Color 8-Bit Panel Timing (Format 2)

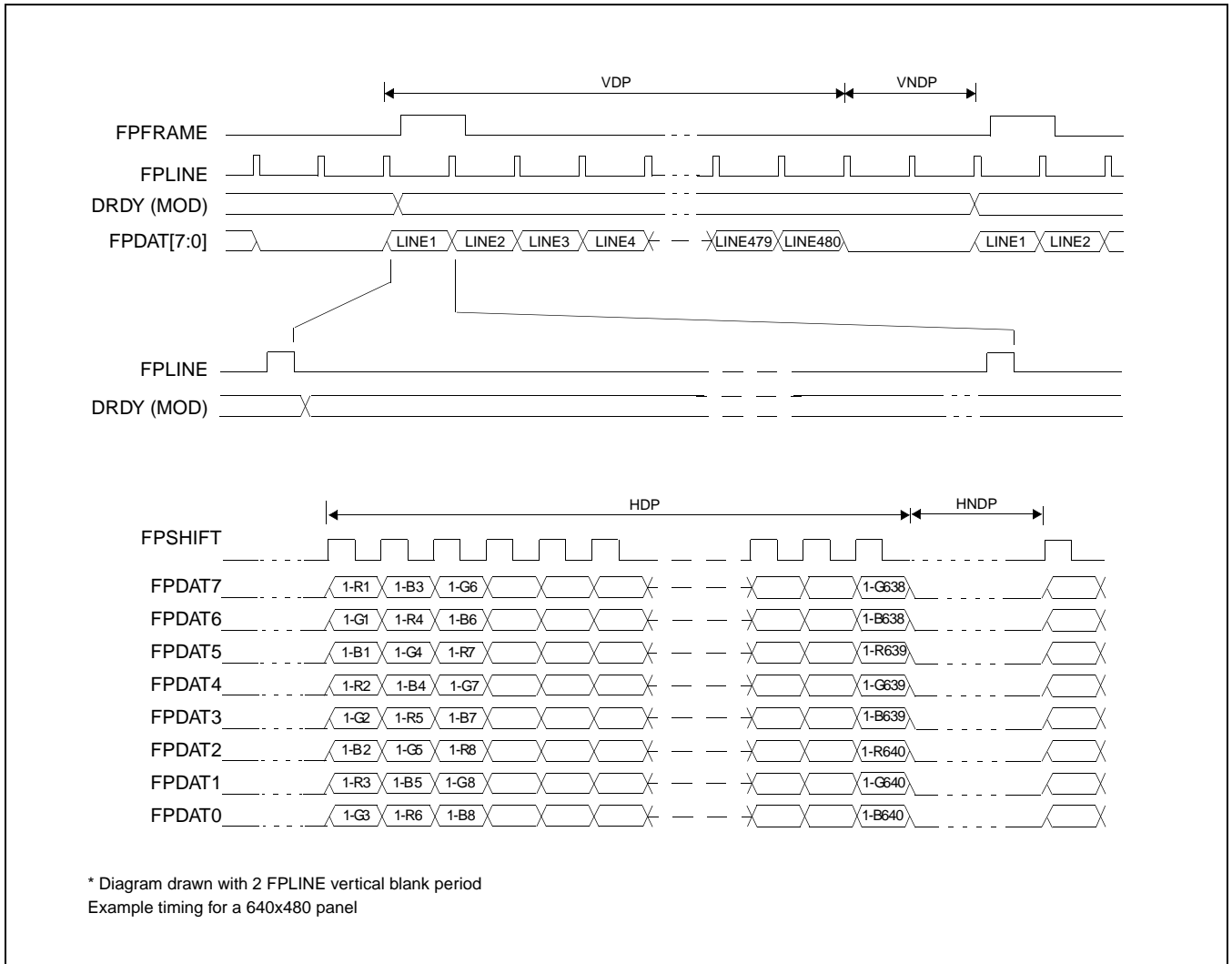

Figure 7-18: Single Color 8-Bit Panel Timing (Format 2)

- |        |                               |  |
|--------|-------------------------------|--|
| VDP =  | Vertical Display Period       | = (REG[06h] bits 1-0, REG[05h] bits 7-0) + 1 Lines |
| VNDP = | Vertical Non-Display Period   | = REG[0Ah] bits 5-0 Lines                          |
| HDP =  | Horizontal Display Period     | = ((REG[04h] bits 6-0) + 1) x 8Ts                  |
| HNDP = | Horizontal Non-Display Period | = (REG[08h] + 4) x 8Ts                             |

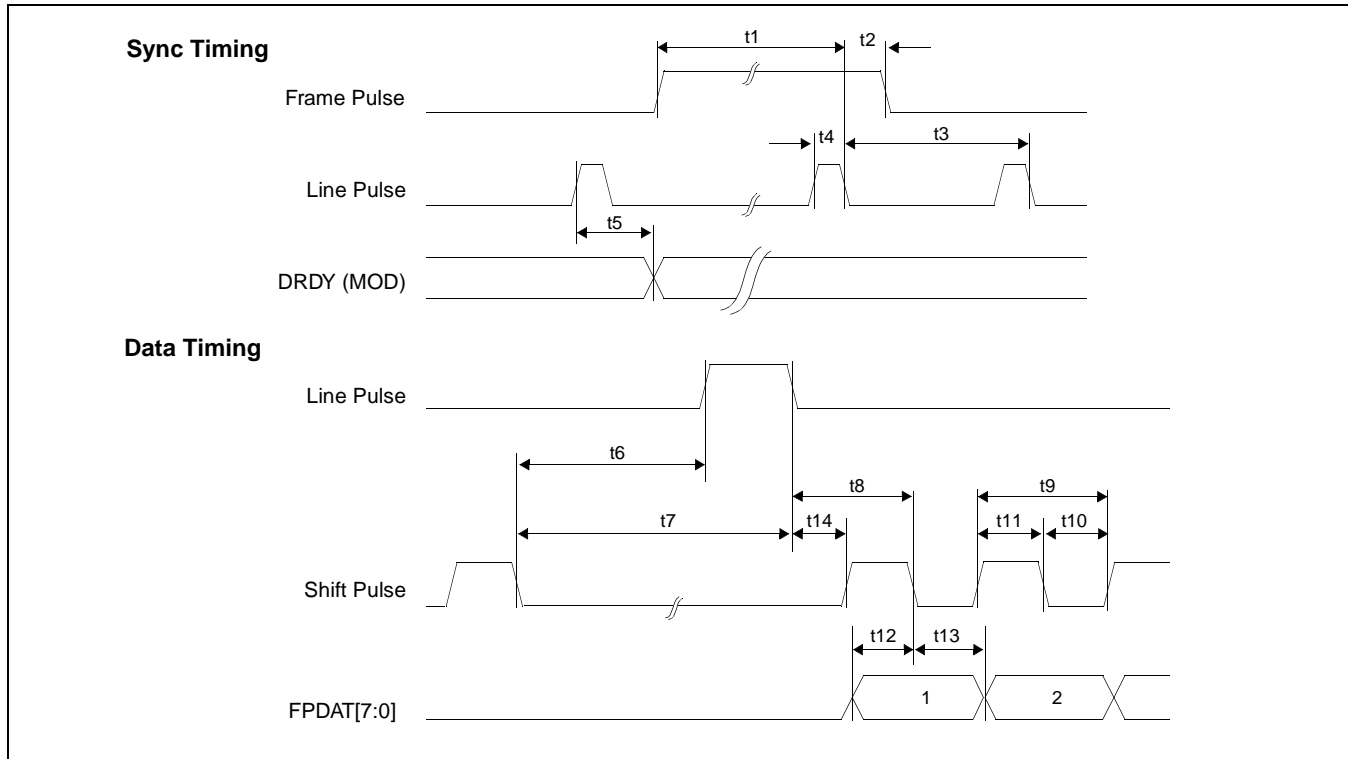

Figure 7-19: Single Color 8-Bit Panel A.C. Timing (Format 2)

Table 7-14: Single Color 8-Bit Panel A.C. Timing (Format 2)

Symbol	Parameter	Min	Typ	Max	Units
t1	Frame Pulse setup to Line Pulse falling edge	note 2			(note 1)
t2	Frame Pulse hold from Line Pulse falling edge	9			Ts
t3	Line Pulse period	note 3			
t4	Line Pulse pulse width	9			Ts
t5	MOD delay from Line Pulse rising edge	1			Ts
t6	Shift Pulse falling edge to Line Pulse rising edge	note 4			
t7	Shift Pulse falling edge to Line Pulse falling edge	note 5			
t8	Line Pulse falling edge to Shift Pulse falling edge	t14 + 2			Ts
t9	Shift Pulse period	2			Ts
t10	Shift Pulse pulse width low	1			Ts
t11	Shift Pulse pulse width high	1			Ts
t12	FPDAT[7:0] setup to Shift Pulse falling edge	1			Ts
t13	FPDAT[7:0] hold to Shift Pulse falling edge	1			Ts
t14	Line Pulse falling edge to Shift Pulse rising edge	23			Ts

1. Ts = pixel clock period
2.  $t1_{min} = t3_{min} - 9Ts$
3.  $t3_{min} = [((REG[04h] \text{ bits } 6-0)+1) \times 8 + ((REG[08h] \text{ bits } 4-0) + 4) \times 8]Ts$
4.  $t6_{min} = [(REG[08h] \text{ bits } 4-0) \times 8 + 1]Ts$
5.  $t7_{min} = [(REG[08h] \text{ bits } 4-0) \times 8 + 10]Ts$

### 7.3.8 Dual Monochrome 8-Bit Panel Timing

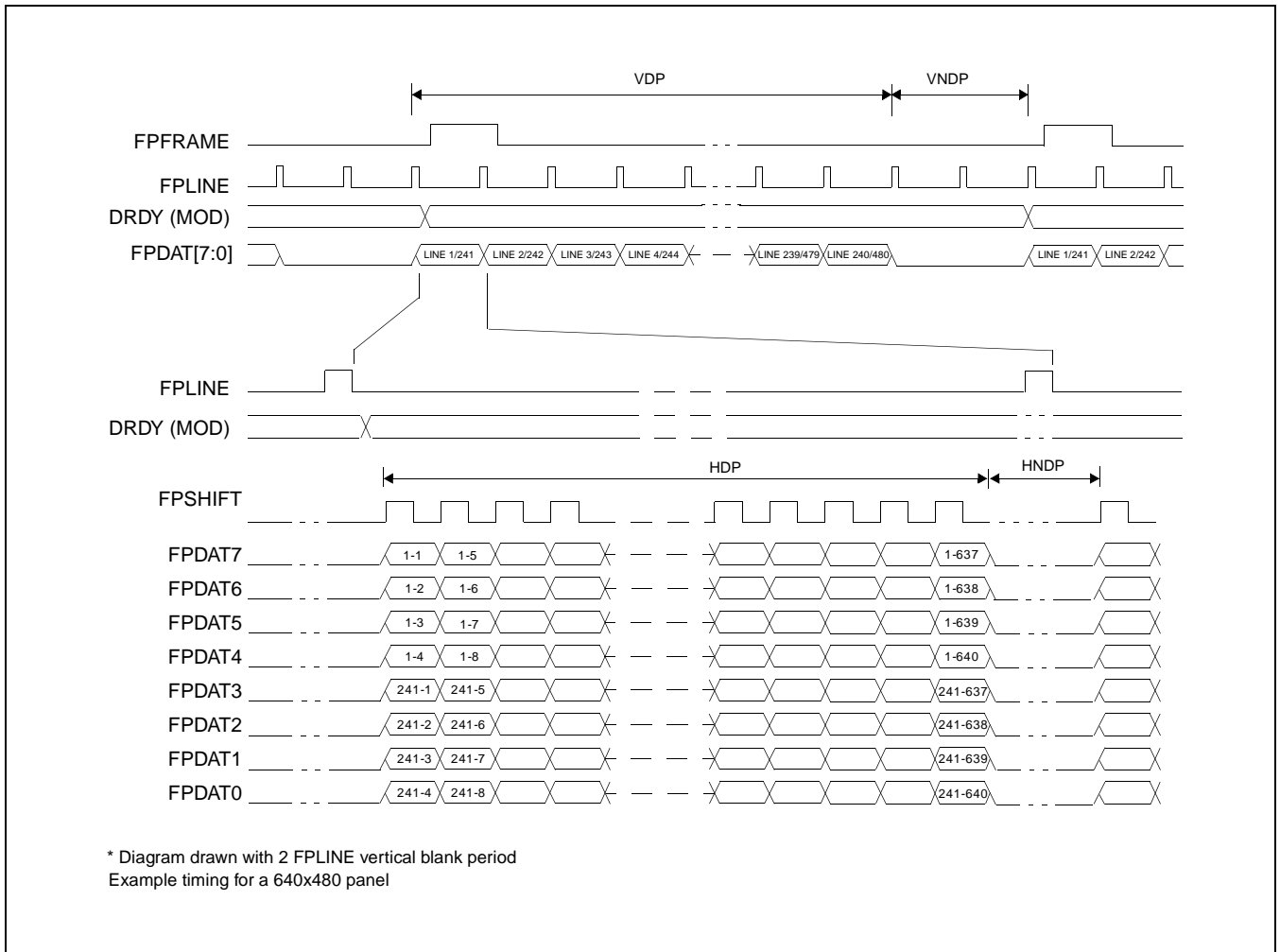

Figure 7-20: Dual Monochrome 8-Bit Panel Timing

- |        |                               |  |
|--------|-------------------------------|--|
| VDP =  | Vertical Display Period       | = (REG[06h] bits 1-0, REG[05h] bits 7-0) + 1 Lines |
| VNDP = | Vertical Non-Display Period   | = REG[0Ah] bits 5-0 Lines                          |
| HDP =  | Horizontal Display Period     | = ((REG[04h] bits 6-0) + 1) x 8Ts                  |
| HNDP = | Horizontal Non-Display Period | = (REG[08h] + 4) x 8Ts                             |

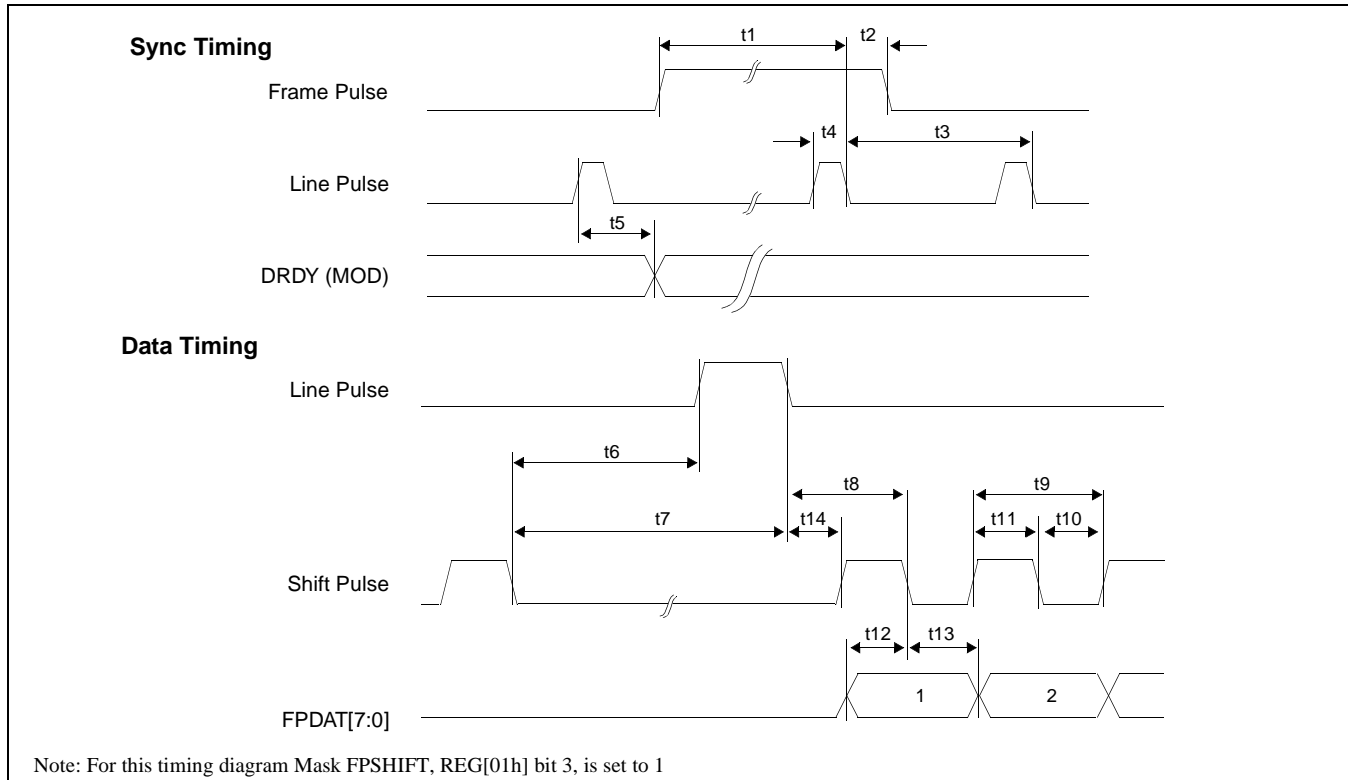

Figure 7-21: Dual Monochrome 8-Bit Panel A.C. Timing

Table 7-15: Dual Monochrome 8-Bit Panel A.C. Timing

Symbol	Parameter	Min	Typ	Max	Units
t1	Frame Pulse setup to Line Pulse falling edge	note 2			(note 1)
t2	Frame Pulse hold from Line Pulse falling edge	9			Ts
t3	Line Pulse period	note 3			
t4	Line Pulse pulse width	9			Ts
t5	MOD delay from Line Pulse falling edge	1			Ts
t6	Shift Pulse falling edge to Line Pulse rising edge	note 5			
t7	Shift Pulse falling edge to Line Pulse falling edge	note 6			
t8	Line Pulse falling edge to Shift Pulse falling edge	t14 + 4			Ts
t9	Shift Pulse period	8			Ts
t10	Shift Pulse pulse width low	4			Ts
t11	Shift Pulse pulse width high	4			Ts
t12	FPDAT[7:0] setup to Shift Pulse falling edge	4			Ts
t13	FPDAT[7:0] hold to Shift Pulse falling edge	4			Ts
t14	Line Pulse falling edge to Shift Pulse rising edge	39			Ts

1. Ts = pixel clock period
2.  $t1_{min} = t3_{min} - 9Ts$
3.  $t3_{min} = [(((REG[04h] \text{ bits } 6-0)+1) \times 8 + ((REG[08h] \text{ bits } 4-0) + 4) \times 8) \times 2]Ts$
5.  $t6_{min} = [((REG[08h] \text{ bits } 4-0) \times 2) \times 8 + 20]Ts$
6.  $t7_{min} = [((REG[08h] \text{ bits } 4-0) \times 2) \times 8 + 29]Ts$



### 7.3.9 Dual Color 8-Bit Panel Timing

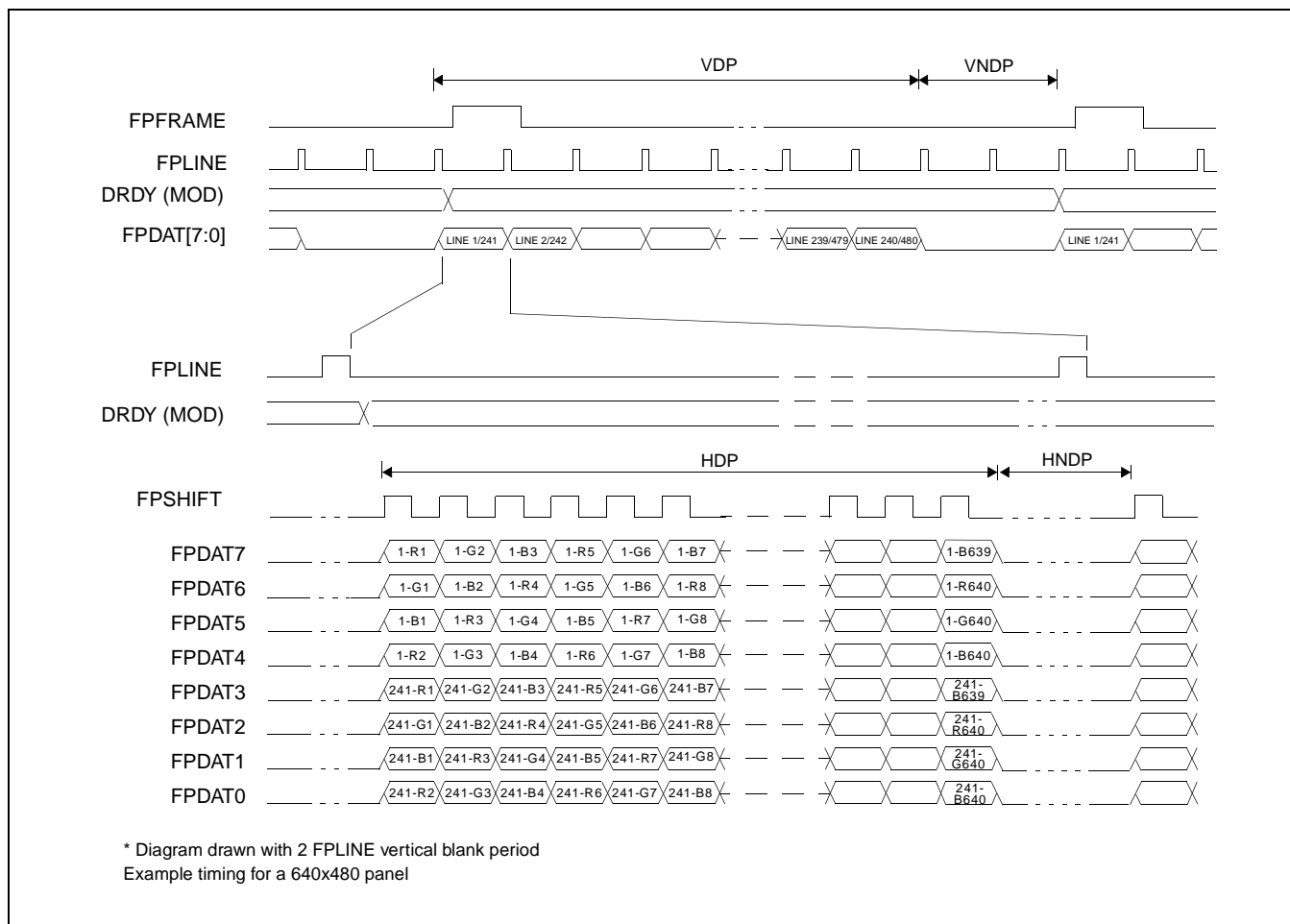

Figure 7-22: Dual Color 8-Bit Panel Timing

- VDP = Vertical Display Period = (REG[06h] bits 1-0, REG[05h] bits 7-0) + 1 Lines
- VNDP = Vertical Non-Display Period = REG[0Ah] bits 5-0 Lines
- HDP = Horizontal Display Period = ((REG[04h] bits 6-0) + 1) x 8Ts
- HNDP = Horizontal Non-Display Period = (REG[08h] + 4) x 8Ts

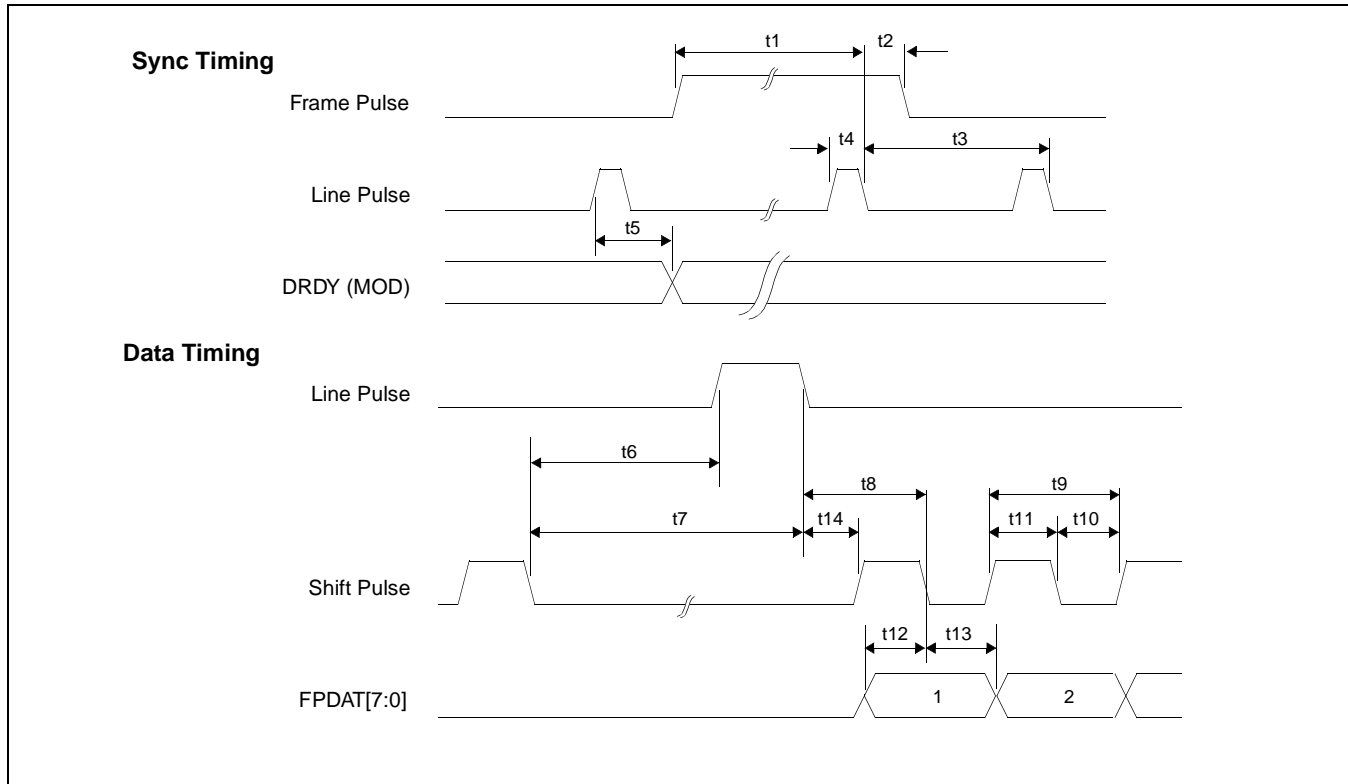

Figure 7-23: Dual Color 8-Bit Panel A.C. Timing

Table 7-16: Dual Color 8-Bit Panel A.C. Timing

Symbol	Parameter	Min	Typ	Max	Units
t1	Frame Pulse setup to Line Pulse falling edge	note 2			(note 1)
t2	Frame Pulse hold from Line Pulse falling edge	9			Ts
t3	Line Pulse period	note 3			
t4	Line Pulse pulse width	9			Ts
t5	MOD delay from Line Pulse falling edge	1			Ts
t6	Shift Pulse falling edge to Line Pulse rising edge	note 5			
t7	Shift Pulse falling edge to Line Pulse falling edge	note 6			
t8	Line Pulse falling edge to Shift Pulse falling edge	t14 + 1			Ts
t9	Shift Pulse period	2			Ts
t10	Shift Pulse pulse width low	1			Ts
t11	Shift Pulse pulse width high	1			Ts
t12	FPDAT[7:0] setup to Shift Pulse falling edge	1			Ts
t13	FPDAT[7:0] hold to Shift Pulse falling edge	1			Ts
t14	Line Pulse falling edge to Shift Pulse rising edge	39			Ts

1. Ts = pixel clock period
2.  $t1_{\min} = t3_{\min} - 9Ts$
3.  $t3_{\min} = [(((REG[04h] \text{ bits } 6-0)+1) \times 8 + ((REG[08h] \text{ bits } 4-0) + 4) \times 8) \times 2]Ts$
5.  $t6_{\min} = [((REG[08h] \text{ bits } 4-0) \times 2) \times 8 + 17]Ts$
6.  $t7_{\min} = [((REG[08h] \text{ bits } 4-0) \times 2) \times 8 + 26]Ts$

### 7.3.10 9/12-Bit TFT/MD-TFD Panel Timing

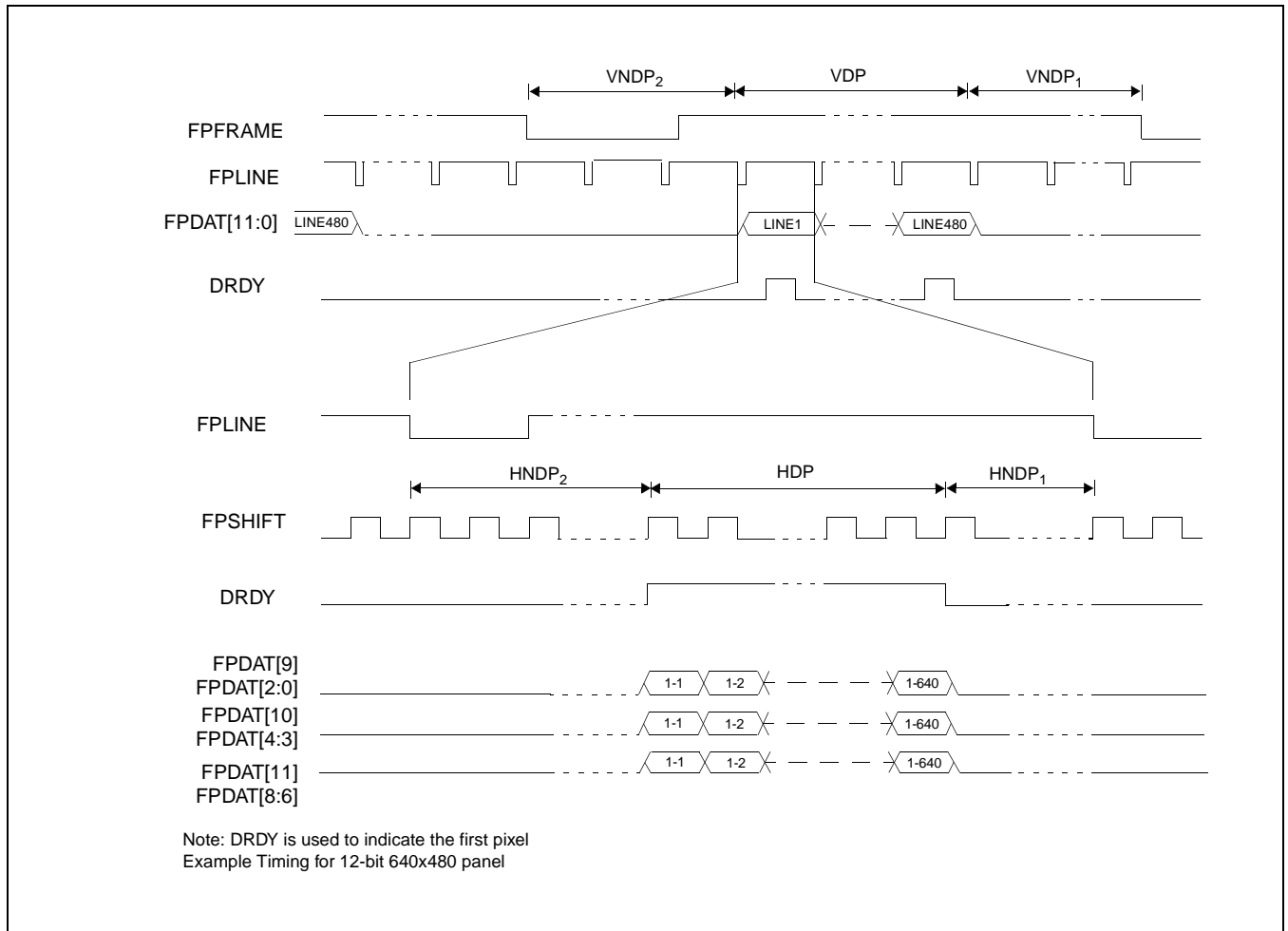

Figure 7-24: 12-Bit TFT/MD-TFD Panel Timing

VDP =	Vertical Display Period	= (REG[06h] bits 1-0, REG[05h] bits 7-0) + 1 Lines
VNDP =	Vertical Non-Display Period	= VNDP1 + VNDP2 = (REG[0Ah] bits 5-0) Lines
VNDP1 =	Vertical Non-Display Period 1	= REG[09h] bits 5-0 Lines
VNDP2 =	Vertical Non-Display Period 2	= (REG[0Ah] bits 5-0) - (REG[09Ah] bits 5-0) Lines
HDP =	Horizontal Display Period	= ((REG[04h] bits 6-0) + 1) x 8Ts
HNDP =	Horizontal Non-Display Period	= HNDP1 + HNDP2 = (REG[08h] + 4) x 8Ts
HNDP1 =	Horizontal Non-Display Period 1	= ((REG[07h] bits 4-0) x 8) + 16Ts
HNDP2 =	Horizontal Non-Display Period 2	= (((REG[08h] bits 4-0) - (REG[07h] bits 4-0)) x 8) + 16Ts

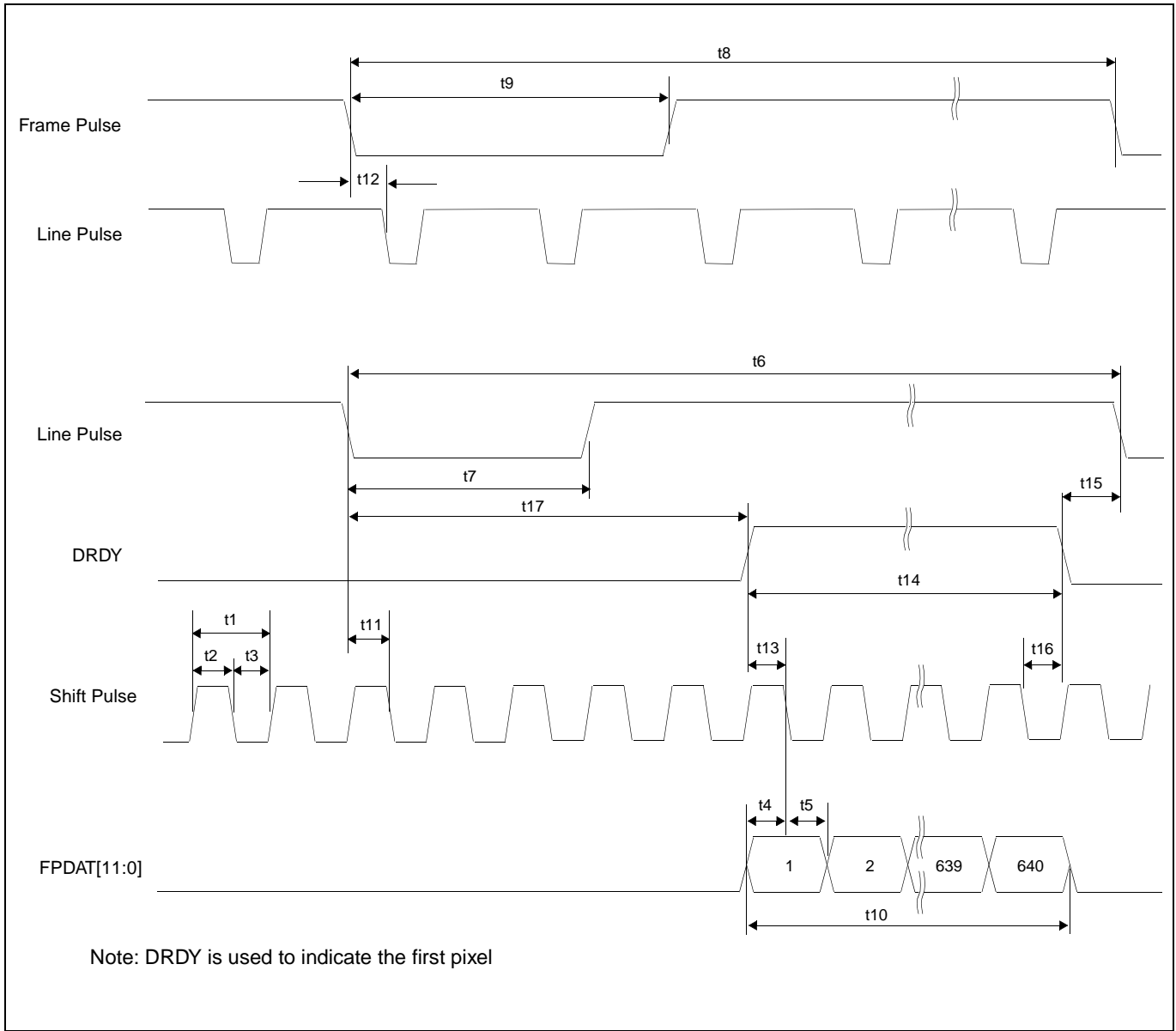

Figure 7-25: TFT/MD-TFD A.C. Timing

Table 7-17: TFT/MD-TFD A.C. Timing

Symbol	Parameter	Min	Typ	Max	Units
t1	Shift Pulse period	1			(note 1)
t2	Shift Pulse pulse width high	0.5			Ts
t3	Shift Pulse pulse width low	0.5			Ts
t4	data setup to Shift Pulse falling edge	0.5			Ts
t5	data hold from Shift Pulse falling edge	0.5			Ts
t6	Line Pulse cycle time	note 2			
t7	Line Pulse pulse width low	9			Ts
t8	Frame Pulse cycle time	note 3			
t9	Frame Pulse pulse width low	2t6			
t10	horizontal display period	note 4			
t11	Line Pulse setup to Shift Pulse falling edge	0.5			Ts
t12	Frame Pulse falling edge to Line Pulse falling edge phase difference	t6 - 18Ts			
t13	DRDY to Shift Pulse falling edge setup time	0.5			Ts
t14	DRDY pulse width	note 5			
t15	DRDY falling edge to Line Pulse falling edge	note 6			
t16	DRDY hold from Shift Pulse falling edge	0.5			Ts
t17	Line Pulse Falling edge to DRDY active	note 7		250	

1. Ts = pixel clock period
2. t6min = [((REG[04h] bits 6-0)+1) x 8 + ((REG[08h] bits 4-0)+4) x 8] Ts
3. t8 min = [((REG[06h] bits 1-0, REG[05h] bits 7-0)+1) + (REG[0Ah] bits 6-0)] Lines
4. t10min = [((REG[04h] bits 6-0)+1) x 8] Ts
5. t14min = [((REG[04h] bits 6-0)+1) x 8] Ts
6. t15min = [(REG[07h] bits 4-0) x 8 + 16] Ts
7. t17min = [(REG[08h] bits 4-0) - (REG[07]) x 8 + 16] Ts

## 8 Registers

### 8.1 Register Mapping

The SED1375 registers are located in the upper 32 bytes of the 128K byte SED1375 address range. The registers are accessible when CS# = 0 and AB[16:0] are in the range 1FFE0h through 1FFFFh.

### 8.2 Register Descriptions

Unless specified otherwise, all register bits are reset to 0 during power up. All bits marked n/a should be programmed 0.

REG[00h] Revision Code Register							Read Only.
Address = 1FFE0h							
Product Code Bit 5	Product Code Bit 4	Product Code Bit 3	Product Code Bit 2	Product Code Bit 1	Product Code Bit 0	Revision Code Bit 1	Revision Code Bit 0

- bits 7-2                      Product Code  
This is a read-only register that indicates the product code of the chip. The product code is 001001.
- bits 1-0                      Revision Code  
This is a read-only register that indicates the revision code of the chip. The revision code is 00.

REG[01h] Mode Register 0							Read/Write.
Address = 1FFE1h							
TFT/STN	Dual/Single	Color/Mono	FPLine Polarity	FPFrame Polarity	Mask FSHIFT	Data Width Bit 1	Data Width Bit 0

- bit 7                              TFT/STN  
When this bit = 0, STN (passive) panel mode is selected. When this bit = 1, TFT/MD-TFD panel mode is selected. If TFT/MD-TFD panel mode is selected, Dual/Single (REG[01h] bit 6) and Color/Mono (REG[01h] bit5) are ignored. See Table 8-1: “Panel Data Format” for a comprehensive description of panel selection.
- bit 6                              Dual/Single  
When this bit = 0, Single LCD panel drive is selected. When this bit = 1, Dual LCD panel drive is selected. See Table 8-1: “Panel Data Format” for a comprehensive description of panel selection.
- bit 5                              Color/Mono  
When this bit = 0, Monochrome LCD panel drive is selected. When this bit = 1, Color LCD panel drive is selected. See Table 8-1: “Panel Data Format” for a comprehensive description of panel selection.

- bit 4                    FPLINE Polarity  
This bit controls the polarity of FPLINE in TFT/MD-TFD mode (no effect in passive panel mode). When this bit = 0, FPLINE is active low. When this bit = 1, FPLINE is active high.
- bit 3                    FPFRAME Polarity  
This bit controls the polarity of FPFRAME in TFT/MD-TFD mode (no effect in passive panel mode). When this bit = 0, FPFRAME is active low. When this bit = 1, FPFRAME is active high.
- bit 2                    Mask FPSHIFT  
FPSHIFT is masked during non-display periods if either of the following two criteria is met:
1. Color passive panel is selected (REG[01h] bit 5 = 1)
  2. This bit (REG[01h] bit 2) = 1
- bits 1-0                Data Width Bits [1:0]  
These bits select the display data format. See Table 8-1: “Panel Data Format” below for a comprehensive description of panel selection.

Table 8-1: Panel Data Format

TFT/STN REG[01h] bit 7	Color/Mono REG[01h] bit 5	Dual/Single REG[01h] bit 6	Data Width Bit 1 REG[01h] bit 1	Data Width Bit 0 REG[01h] bit 0	Function
0	0	0	0	0	Mono Single 4-bit passive LCD
				1	Mono Single 8-bit passive LCD
		1	0	0	reserved
				1	reserved
		1	1	0	reserved
				1	Mono Dual 8-bit passive LCD
	1	0	0	0	Color Single 4-bit passive LCD
				1	Color Single 8-bit passive LCD format 1
			1	reserved	
		1	1	0	Color Single 8-bit passive LCD format 2
				0	reserved
				1	Color Dual 8-bit passive LCD
1	X (don't care)	X (don't care)	0	9-bit TFT/MD-TFD panel	
			1	12-bit TFT/MD-TFD panel	

<b>REG[02h] Mode Register 1</b> Address = 1FFE2h							Read/Write.
Bit-Per-Pixel Bit 1	Bit-Per-Pixel Bit 0	High Performance	Input Clock divide (CLKI/2)	Display Blank	Frame Repeat	Hardware Video Invert Enable	Software Video Invert

bits 7-6

Bit-Per-Pixel Bits [1:0]

These bits select the color or gray-scale depth (Display Mode).

Table 8-2: Gray Scale/Color Mode Selection

Color/Mono REG[01h] bit 6	Bit-Per-Pixel Bit 1 REG[02h] bit 7	Bit-Per-Pixel Bit 0 REG[02h] bit 6	Display Mode	
0	0	0	2 Gray scale	1 bit-per-pixel
		1	4 Gray scale	2 bit-per-pixel
	1	0	16 Gray scale	4 bit-per-pixel
		1	reserved	
1	0	0	2 Colors	1 bit-per-pixel
		1	4 Colors	2 bit-per-pixel
	1	0	16 Colors	4 bit-per-pixel
		1	256 Colors	8 bit-per-pixel

bit 5

High Performance (Landscape Modes Only)

When this bit = 0, the internal Memory Clock (MCLK) is a divided-down version of the Pixel Clock (PCLK). The denominator is dependent on the bit-per-pixel mode - see the table below.

Table 8-3: High Performance Selection

High Performance	BPP Bit 1	BPP Bit 0	Display Modes	
0	0	0	MCLK = PCLK/8	1 bit-per-pixel
		1	MCLK = PCLK/4	2 bit-per-pixel
	1	0	MCLK = PCLK/2	4 bit-per-pixel
		1	MCLK = PCLK	8 bit-per-pixel
1	X	X	MCLK = PCLK	

When this bit = 1, MCLK is fixed to the same frequency as PCLK for all bit-per-pixel modes. This provides a faster screen update performance in 1/2/4 bit-per-pixel modes, but also increases power consumption. This bit can be set to 1 just before a major screen update, then set back to 0 to save power after the update. This bit has no effect in Swivel-View mode. Refer to REG[1Bh] SwivelView Mode Register on page 66 for SwivelView mode clock selection.



- bit 4                      Input Clock Divide  
When this bit = 0, the Operating Clock(CLK) is the same as the Input Clock (CLKI).  
When this bit = 1, CLK = CLKI/2.
- In landscape mode PCLK=CLK and MCLK is selected as per Table 8-3: “High Performance Selection”.
- In SwivelView mode, MCLK and PCLK are derived from CLK as shown in Table 8-8: “Selection of PCLK and MCLK in SwivelView Mode,” on page 67.
- bit 3                      Display Blank  
This bit blanks the display image. When this bit = 1, the display is blanked (FPDAT lines to the panel are driven low). When this bit = 0, the display is enabled.
- bit 2                      Frame Repeat (EL support)  
This feature is used to improve Frame Rate Modulation of EL panels. When this bit = 1, an internal frame counter runs from 0 to 3FFFFh. When the frame counter rolls over, the modulated image pattern is repeated (every 1 hour when the frame rate is 72Hz). When this bit = 0, the modulated image pattern is never repeated.
- bit 1                      Hardware Video Invert Enable  
In passive panel modes (REG[01h] bit 7 = 0) FPDAT11 is available as either GPIO4 or hardware video invert. When this bit = 1, Hardware Video Invert is enabled via the FPDAT11 pin. When this bit = 0, FPDAT11 operates as GPIO4. See Table 8-4: “Inverse Video Mode Select Options” below.

**Note**

Video data is inverted after the Look-Up Table.

- bit 0                      Software Video Invert  
When this bit = 1, Inverse Video Mode is selected. When this bit = 0, Standard Video Mode is selected. See Table 8-4: “Inverse Video Mode Select Options” below.

**Note**

Video data is inverted after the Look-Up Table.

*Table 8-4: Inverse Video Mode Select Options*

Hardware Video Invert Enable	Software Video Invert (Passive and Active Panels)	FPDAT11 (Passive Panels Only)	Video Data
0	0	X	Normal
0	1	X	Inverse
1	X	0	Normal
1	X	1	Inverse

REG[03h] Mode Register 2							Read/Write	
Address = 1FFE3h								
n/a	n/a	n/a	n/a	LCDPWR Override	Hardware Power Save Enable	Software Power Save Bit 1	Software Power Save Bit 0	

bit 3                      LCDPWR Override  
This bit is used to override the panel on/off sequencing logic. When this bit = 0, LCDPWR and the panel interface signals are controlled by the sequencing logic. When this bit = 1, LCDPWR is forced to off and the panel interface signals are forced low immediately upon entering power save mode. See Section 7.3.2, “Power Down/Up Timing” on page 36 for further information.

bit 2                      Hardware Power Save Enable  
When this bit = 1 GPIO0 is used as the Hardware Power Save input pin. When this bit = 0, GPIO0 operates normally.

Table 8-5: Hardware Power Save/GPIO0 Operation

RESET# State	Hardware Power Save Enable REG[03h] bit 2	GPIO0 Config REG[18h] bit 0	GPIO0 Status/Control REG[19h] bit 0	GPIO0 Operation
0	X	X	X	
1	0	0	reads pin status	GPIO0 Input (high impedance)
1	0	1	0	GPIO0 Output = 0
1	0	1	1	GPIO0 Output = 1
1	1	X	X	Hardware Power Save Input (active high)

bits 1-0                      Software Power Save Bits [1: 0]  
These bits select the Power Save Mode as shown in the following table.

Table 8-6: Software Power Save Mode Selection

Bit 1	Bit 0	Mode
0	0	Software Power Save
0	1	reserved
1	0	reserved
1	1	Normal Operation

Refer to Section 13, “Power Save Modes” on page 81 for a complete description of the power save modes.

<b>REG[04h] Horizontal Panel Size Register</b>							Read/Write
Address = 1FFE4h							
n/a	Horizontal Panel Size Bit 6	Horizontal Panel Size Bit 5	Horizontal Panel Size Bit 4	Horizontal Panel Size Bit 3	Horizontal Panel Size Bit 2	Horizontal Panel Size Bit 1	Horizontal Panel Size Bit 0

bits 6-0

Horizontal Panel Size Bits [6:0]

This register determines the horizontal resolution of the panel. This register must be programmed with a value calculated as follows:

$$\text{HorizontalPanelSizeRegister} = \left( \frac{\text{HorizontalPanelResolution(pixels)}}{8} \right) - 1$$

**Note**

This register must not be set to a value less than 03h.

<b>REG[05h] Vertical Panel Size Register (LSB)</b>							Read/Write
Address = 1FFE5h							
Vertical Panel Size Bit 7	Vertical Panel Size Bit 6	Vertical Panel Size Bit 5	Vertical Panel Size Bit 4	Vertical Panel Size Bit 3	Vertical Panel Size Bit 2	Vertical Panel Size Bit 1	Vertical Panel Size Bit 0

<b>REG[06h] Vertical Panel Size Register (MSB)</b>							Read/Write
Address = 1FFE6h							
n/a	n/a	n/a	n/a	n/a	n/a	Vertical Panel Size Bit 9	Vertical Panel Size Bit 8

REG[05h] bits 7-0

Vertical Panel Size Bits [9:0]

REG[06h] bits 1-0

This 10-bit register determines the vertical resolution of the panel. This register must be programmed with a value calculated as follows:

$$\text{VerticalPanelSizeRegister} = \text{VerticalPanelResolution(lines)} - 1$$

3FFh is the maximum value of this register for a vertical resolution of 1024 lines.

REG[07h] FPLINE Start Position							Read/Write
Address = 1FFE7h							
n/a	n/a	n/a	FPLINE Start Position Bit 4	FPLINE Start Position Bit 3	FPLINE Start Position Bit 2	FPLINE Start Position Bit 1	FPLINE Start Position Bit 0

bits 4-0

**FPLINE Start Position**

These bits are used in TFT/MD-TFD mode to specify the position of the FPLINE pulse. These bits specify the delay, in 8-pixel resolution, from the end of a line of display data (FPDAT) to the leading edge of FPLINE. This register is effective in TFT/MD-TFD mode only (REG[01h] bit 7 = 1). This register is programmed as follows:

$$\text{FPLINEposition(pixels)} = (\text{REG}[07\text{h}] + 2) \times 8$$

The following constraint must be satisfied:

$$\text{REG}[07\text{h}] \leq \text{REG}[08\text{h}]$$

REG[08h] Horizontal Non-Display Period							Read/Write
Address = 1FFE8h							
n/a	n/a	n/a	Horizontal Non-Display Period Bit 4	Horizontal Non-Display Period Bit 3	Horizontal Non-Display Period Bit 2	Horizontal Non-Display Period Bit 1	Horizontal Non-Display Period Bit 0

bits 4-0

**Horizontal Non-Display Period**

These bits specify the horizontal non-display period in 8-pixel resolution.

$$\text{HorizontalNonDisplayPeriod(pixels)} = (\text{REG}[08\text{h}] + 4) \times 8$$

REG[09h] FPFAME Start Position							Read/Write
Address = 1FFE9h							
n/a	n/a	FPFRAME Start Position Bit 5	FPFRAME Start Position Bit 4	FPFRAME Start Position Bit 3	FPFRAME Start Position Bit 2	FPFRAME Start Position Bit 1	FPFRAME Start Position Bit 0

bits 5-0

**FPFRAME Start Position**

These bits are used in TFT/MD-TFD mode to specify the position of the FPFAME pulse. These bits specify the number of lines between the last line of display data (FPDAT) and the leading edge of FPFAME. This register is effective in TFT/MD-TFD mode only (REG[01h] bit 7 = 1). This register is programmed as follows:

$$\text{FPFRAMEposition(lines)} = \text{REG}[09\text{h}]$$

The contents of this register must be greater than zero and less than or equal to the Vertical Non-Display Period Register, i.e.

$$1 \leq \text{REG}[09\text{h}] \leq \text{REG}[0A\text{h}]$$

<b>REG[0Ah] Vertical Non-Display Period</b>							Read/Write
Address = 1FFEAh							
Vertical Non-Display Status	n/a	Vertical Non-Display Period Bit 5	Vertical Non-Display Period Bit 4	Vertical Non-Display Period Bit 3	Vertical Non-Display Period Bit 2	Vertical Non-Display Period Bit 1	Vertical Non-Display Period Bit 0

bit 7                      Vertical Non-Display Status  
This bit =1 during the Vertical Non-Display period.

bits 5-0                Vertical Non-Display Period  
These bits specify the vertical non-display period. This register is programmed as follows:

$$\text{VerticalNonDisplayPeriod}(\text{lines}) = \text{REG}[0\text{Ah}] \text{ bits } [5:0]$$

**Note**

This register should be set only once, on power-up during initialization.

<b>REG[0Bh] MOD Rate Register</b>							Read/Write
Address = 1FFEBh							
n/a	n/a	MOD Rate Bit 5	MOD Rate Bit 4	MOD Rate Bit 3	MOD Rate Bit 2	MOD Rate Bit 1	MOD Rate Bit 0

bits 5-0                MOD Rate Bits [5:0]  
When the value of this register is 0, the MOD output signal toggles every FPFRAME. For a non-zero value, the value in this register + 1 specifies the number of FPLINEs between toggles of the MOD output signal. These bits are for passive LCD panels only.

REG[0Ch] Screen 1 Start Address Register (LSB)							Read/Write
Address = 1FFECh							
Screen 1 Start Address Bit 7	Screen 1 Start Address Bit 6	Screen 1 Start Address Bit 5	Screen 1 Start Address Bit 4	Screen 1 Start Address Bit 3	Screen 1 Start Address Bit 2	Screen 1 Start Address Bit 1	Screen 1 Start Address Bit 0

REG[0Dh] Screen 1 Start Address Register (MSB)							Read/Write
Address = 1FFEDh							
Screen 1 Start Address Bit 15	Screen 1 Start Address Bit 14	Screen 1 Start Address Bit 13	Screen 1 Start Address Bit 12	Screen 1 Start Address Bit 11	Screen 1 Start Address Bit 10	Screen 1 Start Address Bit 9	Screen 1 Start Address Bit 8

REG[0Dh] bits 7-0 Screen 1 Start Address Bits [15:0]

REG[0Ch] bits 7-0 These bits determine the **word address** of the start of Screen 1 in Landscape modes or the **byte address** of the start of Screen 1 in SwivelView modes.

**Note**

For SwivelView mode the most significant bit (bit 16) is located in REG[10h].

REG[0Eh] Screen 2 Start Address Register (LSB)							Read/Write
Address = 1FFEEh							
Screen 2 Start Address Bit 7	Screen 2 Start Address Bit 6	Screen 2 Start Address Bit 5	Screen 2 Start Address Bit 4	Screen 2 Start Address Bit 3	Screen 2 Start Address Bit 2	Screen 2 Start Address Bit 1	Screen 2 Start Address Bit 0

REG[0Fh] Screen 2 Start Address Register (MSB)							Read/Write
Address = 1FFEFh							
Screen 2 Start Address Bit 15	Screen 2 Start Address Bit 14	Screen 2 Start Address Bit 13	Screen 2 Start Address Bit 12	Screen 2 Start Address Bit 11	Screen 2 Start Address Bit 10	Screen 2 Start Address Bit 9	Screen 2 Start Address Bit 8

REG[0Fh] bits 7-0 Screen 2 Start Address Bits [15:0]

REG[0Eh] bits 7-0 These bits determine the **word address** of the start of Screen 2 in Landscape modes only and has no effect in SwivelView modes.

REG[10h] Screen Start Address Overflow Register							Read/Write
Address = 1FFF0h							
n/a	n/a	n/a	n/a	n/a	n/a	n/a	Screen 1 Start Address Bit 16

bit 0 Screen 1 Start Address Bit 16

This bit is the most significant bit of Screen 1 Start Address for SwivelView mode. This bit has no effect in Landscape mode.

<b>REG[11h] Memory Address Offset Register</b>							Read/Write
Address = 1FFF1h							
Memory Address Offset Bit 7	Memory Address Offset Bit 6	Memory Address Offset Bit 5	Memory Address Offset Bit 4	Memory Address Offset Bit 3	Memory Address Offset Bit 2	Memory Address Offset Bit 1	Memory Address Offset Bit 0

bits 7-0

Memory Address Offset Bits [7:0] (Landscape Modes Only)

This register is used to create a virtual image by setting a word offset between the last address of one line and the first address of the following line. If this register is not equal to zero, then a virtual image is formed. The displayed image is a window into the larger virtual image. See Figure 8-1: “Screen-Register Relationship, Split Screen,” on page 64.

This register has no effect in SwivelView modes. See “REG[1Ch] Line Byte Count Register for SwivelView Mode” on page 67.

<b>REG[12h] Screen 1 Vertical Size Register (LSB)</b>							Read/Write
Address = 1FFF2h							
Screen 1 Vertical Size Bit 7	Screen 1 Vertical Size Bit 6	Screen 1 Vertical Size Bit 5	Screen 1 Vertical Size Bit 4	Screen 1 Vertical Size Bit 3	Screen 1 Vertical Size Bit 2	Screen 1 Vertical Size Bit 1	Screen 1 Vertical Size Bit 0

<b>REG[13h] Screen 1 Vertical Size Register (MSB)</b>							Read/Write
Address = 1FFF3h							
n/a	n/a	n/a	n/a	n/a	n/a	Screen 1 Vertical Size Bit 9	Screen 1 Vertical Size Bit 8

REG[13h] bits 1-0

Screen 1 Vertical Size Bits [9:0]

REG[12h] bits 7-0

This register is used to implement the Split Screen feature of the SED1374. These bits determine the height (in lines) of Screen 1.

In landscape modes, if this register is programmed with a value, n, where n is less than the Vertical Panel Size (REG[06h], REG[05h]), then lines 0 to n of the panel contain Screen 1 and lines n+1 to REG[06h], REG[05h] of the panel contain Screen 2. See Figure 8-1: “Screen-Register Relationship, Split Screen,” on page 64. If Split Screen is not desired, this register must be programmed greater than, or equal to the Vertical Panel Size, REG[06h] and REG[05h].

In SwivelView modes this register must be programmed greater than, or equal to the Vertical Panel Size, REG[06h] and REG[05h]. See “SwivelView™” on page 76.

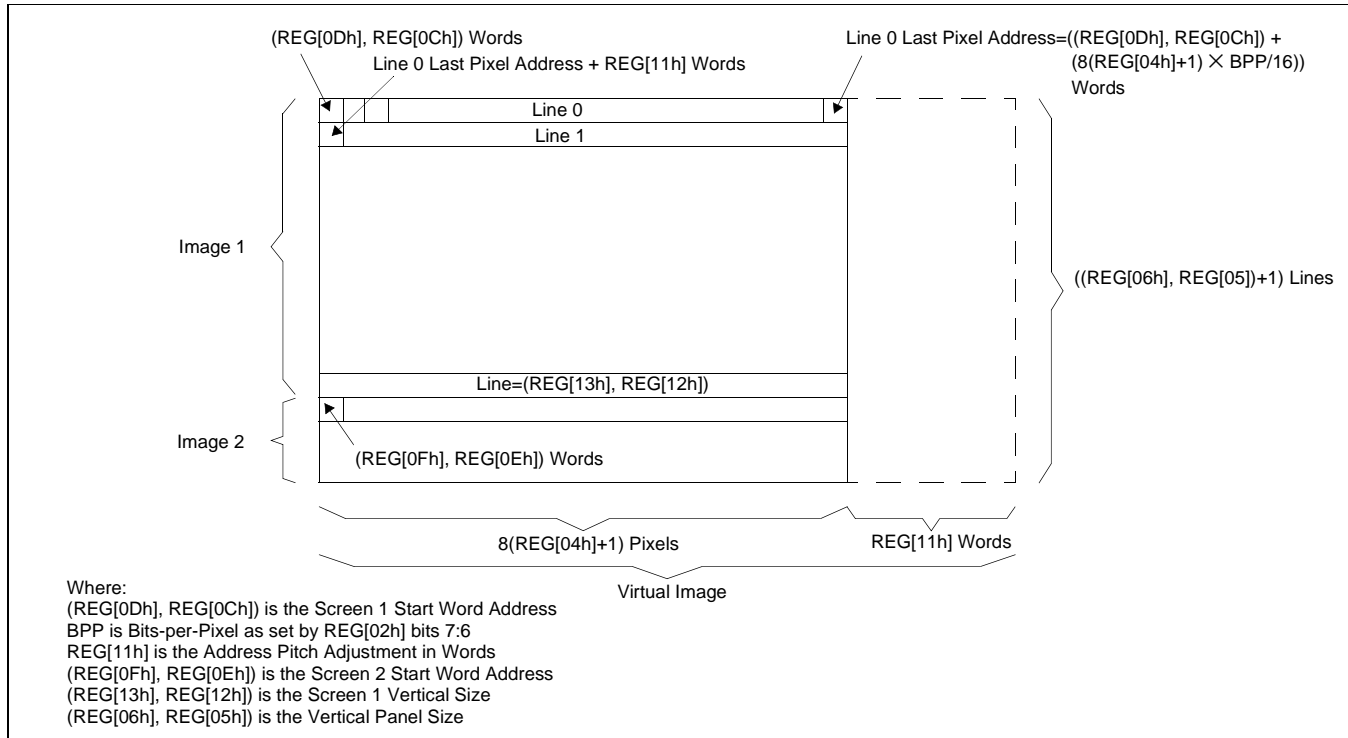

Figure 8-1: Screen-Register Relationship, Split Screen

Consider an example where REG[13h], REG[12] = 0CEh for a 320x240 display system. The upper 207 lines (CEh + 1) of the panel show an image from the Screen 1 Start Word Address. The remaining 33 lines show an image from the Screen 2 Start Word Address.

### REG[15h] Look-Up Table Address Register

Address = 1FFF5h

Read/Write

LUT Address Bit 7	LUT Address Bit 6	LUT Address Bit 5	LUT Address Bit 4	LUT Address Bit 3	LUT Address Bit 2	LUT Address Bit 1	LUT Address Bit 0
-------------------	-------------------	-------------------	-------------------	-------------------	-------------------	-------------------	-------------------

bits 7-0

LUT Address Bits [7:0]

These 8 bits control a pointer into the Look-Up Tables (LUT). The SED1375 has three 256-position, 4-bit wide LUTs, one for each of red, green, and blue – refer to Section 11, “Look-Up Table Architecture” on page 70 for details.

This register selects which LUT entry is read/write accessible through the LUT Data Register (REG[17h]). Writing the LUT Address Register automatically sets the pointer to the Red LUT. Accesses to the LUT Data Register automatically increment the pointer.

For example, writing a value 03h into the LUT Address Register sets the pointer to R[3]. A subsequent access to the LUT Data Register accesses R[3] and moves the pointer onto G[3]. Subsequent accesses to the LUT Data Register move the pointer onto B[3], R[4], G[4], B[4], R[5], etc.



**Note**

The RGB data is inserted into the LUT after the Blue data is written, i.e. all three colors must be written before the LUT is updated.

REG[17h] Look-Up Table Data Register							Read/Write
Address = 1FFF7h							
LUT Data Bit 3	LUT Data Bit 2	LUT Data Bit 1	LUT Data Bit 0	n/a	n/a	n/a	n/a

bits 7-4

LUT Data Bits [3:0]

This register is used to read/write the RGB Look-Up Tables. This register accesses the entry at the pointer controlled by the Look-Up Table Address Register (REG[15h]).

Accesses to the Look-Up Table Data Register automatically increment the pointer.

**Note**

The RGB data is inserted into the LUT after the Blue data is written, i.e. all three colors must be written before the LUT is updated.

REG[18h] GPIO Configuration Control Register							Read/Write
Address = 1FFF8h							
n/a	n/a	n/a	GPIO4 Pin IO Configuration	GPIO3 Pin IO Configuration	GPIO2 Pin IO Configuration	GPIO1 Pin IO Configuration	GPIO0 Pin IO Configuration

bits 4-0

GPIO[4:0] Pin IO Configuration

These bits determine the direction of the GPIO[4:0] pins.

When the GPIO Pin IO Configuration bit = 0, the corresponding GPIO pin is configured as an input. The input can be read at the GPIO Status/Control Register bit. See REG[19h] GPIO Status/Control Register.

When the GPIO Pin IO Configuration bit = 1, the corresponding GPIO pin is configured as an output. The output can be controlled by writing the GPIO Status/Control Register bit.

**Note**

These bits have no effect when the GPIO pin is configured for a specific function (i.e. as FPDAT[11:8] for TFT/MD-TFD operation).

When configured as IO, all unused pins must be tied to IO  $V_{DD}$ .

<b>REG[19h] GPIO Status/Control Register</b>							Read/Write
Address = 1FFF9h							
n/a	n/a	n/a	GPIO4 Pin IO Status	GPIO3 Pin IO Status	GPIO2 Pin IO Status	GPIO1 Pin IO Status	GPIO0 Pin IO Status

bits 4-0

GPIO[4:0] Status

When the GPIO pin is configured as an input, the corresponding GPIO Status bit is used to read the pin input. See REG[18h] above.

When the GPIO pin is configured as an output, the corresponding GPIO Status bit is used to control the pin output.

<b>REG[1Ah] Scratch Pad Register</b>							Read/Write
Address = 1FFFAh							
Scratch bit 7	Scratch bit 6	Scratch bit 5	Scratch bit 4	Scratch bit 3	Scratch bit 2	Scratch bit 1	Scratch bit 0

bits 7-0

Scratch Pad Register

This register contains general use read/write bits. These bits have no effect on hardware.

<b>REG[1Bh] SwivelView Mode Register</b>							Read/Write
Address = 1FFFBh							
SwivelView Mode Enable	SwivelView Mode Select	n/a	n/a	n/a	reserved	SwivelView Mode Pixel Clock Select Bit 1	SwivelView Mode Pixel Clock Select Bit 0

bit 7

SwivelView Mode Enable

When this bit = 1, SwivelView Mode is enabled. When this bit = 0, Landscape Mode is enabled.

bit 6

SwivelView Mode Select

When this bit = 0, Default SwivelView Mode is selected. When this bit = 1, Alternate SwivelView Mode is selected. See Section 12, “SwivelView™” on page 76 for further information on SwivelView Mode.

The following table shows the selection of SwivelView Mode.

Table 8-7: Selection of SwivelView Mode

SwivelView Mode Enable (REG[1Bh] bit 7)	SwivelView Mode Select (REG[1Bh] bit 6)	Mode
0	X	Landscape
1	0	Default SwivelView
1	1	Alternate SwivelView

- bit 2 reserved  
reserved bits must be set to 0.
- bits 1-0 SwivelView Mode Pixel Clock Select Bits [1:0]  
These two bits select the Pixel Clock (PCLK) source in SwivelView Mode - these bits have no effect in Landscape Mode. The following table shows the selection of PCLK and MCLK in SwivelView Mode - see Section 12, “SwivelView™” on page 76 for details.

Table 8-8: Selection of PCLK and MCLK in SwivelView Mode

SwivelView Mode Enable (REG[1Bh] bit 7)	SwivelView Mode Select (REG[1Bh] bit 6)	Pixel Clock (PCLK) Select (REG[1Bh] bits [1:0])		PCLK =	MCLK =
		Bit 1	Bit 0		
0	X	X	X	CLK	See Reg[02h] bit 5
1	0	0	0	CLK	CLK
1	0	0	1	CLK/2	CLK/2
1	0	1	0	CLK/4	CLK/4
1	0	1	1	CLK/8	CLK/8
1	1	0	0	CLK/2	CLK
1	1	0	1	CLK/2	CLK
1	1	1	0	CLK/4	CLK/2
1	1	1	1	CLK/8	CLK/4

Where CLK is CLKI (REG[02h] bit 4 = 0) or CLKI/2 (REG[02h] bit 4 = 1)

REG[1Ch] Line Byte Count Register for SwivelView Mode							Read/Write
Address = 1FFFCh							
Line Byte Count bit 7	Line Byte Count bit 6	Line Byte Count bit 5	Line Byte Count bit 4	Line Byte Count bit 3	Line Byte Count bit 2	Line Byte Count bit 1	Line Byte Count bit 0

- bits 7-0 Line Byte Count Bits [7:0]  
This register is the byte count from the beginning of one line to the beginning of the next consecutive line (commonly called “stride” by programmers). This register may be used to create a virtual image in SwivelView mode.
- When this register = 00 the “stride” = 256 bytes. This value is used for 240x320 8 bpp default SwivelView mode
- When the Line Byte Count Register = n, where  $1 \leq n \leq FFh$ , the “stride” = n bytes.

### REG[1Eh] and REG[1Fh]

REG[1Eh] and REG[1Fh] are reserved for factory SED1375 testing and should not be written. Any value written to these registers may result in damage to the SED1375 and/or any panel connected to the SED1375.

## 9 Frame Rate Calculation

The following formulae are used to calculate the display frame rate.

### TFT/MD-TFD and Passive Single-Panel modes

$$\text{FrameRate} = \frac{f_{\text{PCLK}}}{(\text{HDP} + \text{HNDP}) \times (\text{VDP} + \text{VNDP})}$$

Where:  $f_{\text{PCLK}}$  = PClk frequency (Hz)  
 HDP = Horizontal Display Period = ((REG[04h] bits 6-0) + 1) x 8 Pixels  
 HNDP = Horizontal Non-Display Period = ((REG[08h] bits 4-0) + 4) x 8 Pixels  
 VDP = Vertical Display Period = ((REG[06h] bits 1-0, REG[05h] bits 7-0) + 1) Lines  
 VNDP = Vertical Non-Display Period = (REG[0Ah] bits 5-0) Lines

### Passive Dual-Panel mode

$$\text{FrameRate} = \frac{f_{\text{PCLK}}}{2 \times (\text{HDP} + \text{HNDP}) \times \left( \frac{\text{VDP}}{2} + \text{VNDP} \right)}$$

Where:  $f_{\text{PCLK}}$  = PClk frequency (Hz)  
 HDP = Horizontal Display Period = ((REG[04h] bits 6-0) + 1) x 8 Pixels  
 HNDP = Horizontal Non-Display Period = ((REG[08h] bits 4-0) + 4) x 8 Pixels  
 VDP = Vertical Display Period = ((REG[06h] bits 1-0, REG[05h] bits 7-0) + 1) Lines  
 VNDP = Vertical Non-Display Period = (REG[0Ah] bits 5-0) Lines

# 10 Display Data Formats

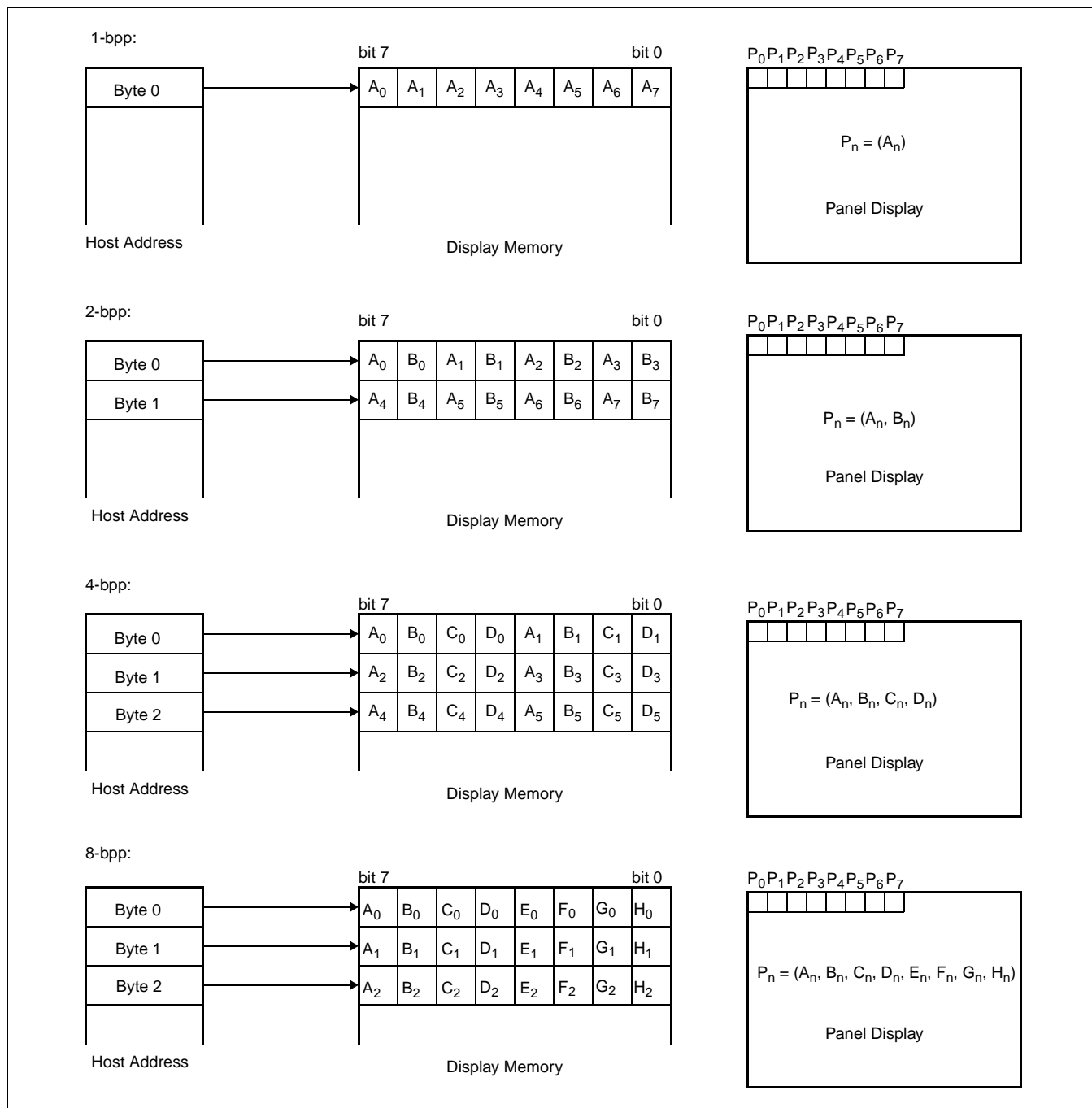

Figure 10-1: 1/2/4/8 Bit-Per-Pixel Display Data Memory Organization

# 11 Look-Up Table Architecture

The following figures are intended to show the display data output path only.

## Note

When Video Data Invert is enabled the video data is inverted after the Look-Up Table.

## 11.1 Monochrome Modes

The green Look-Up Table (LUT) is used for all monochrome modes.

### 1 Bit-per-pixel Monochrome mode

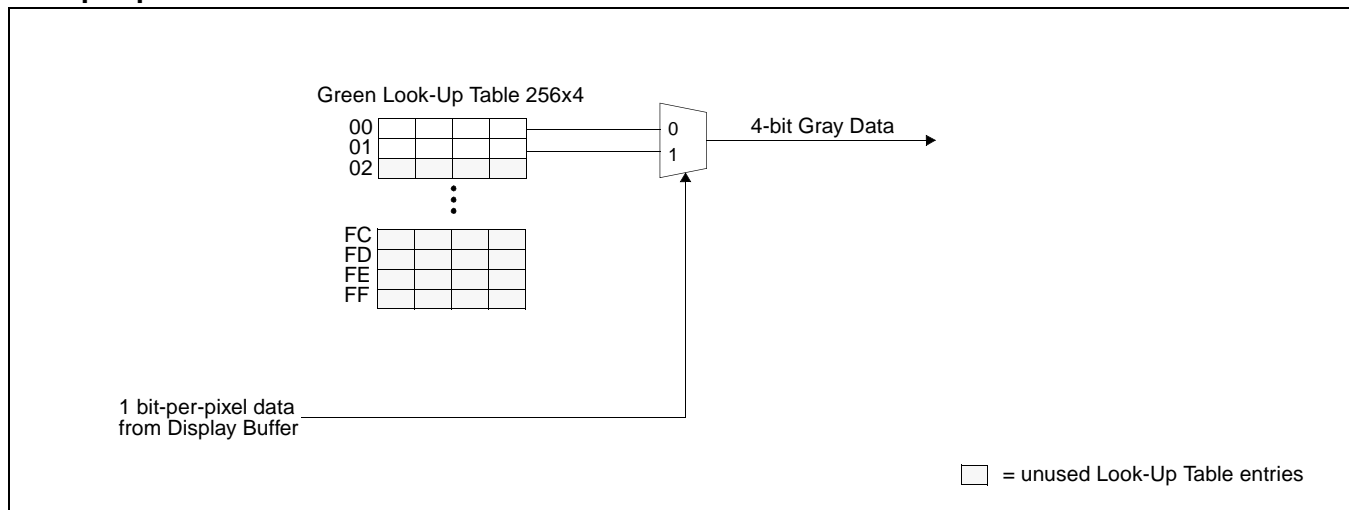

Figure 11-1: 1 Bit-per-pixel Monochrome Mode Data Output Path

### 2 Bit-per-pixel Monochrome Mode

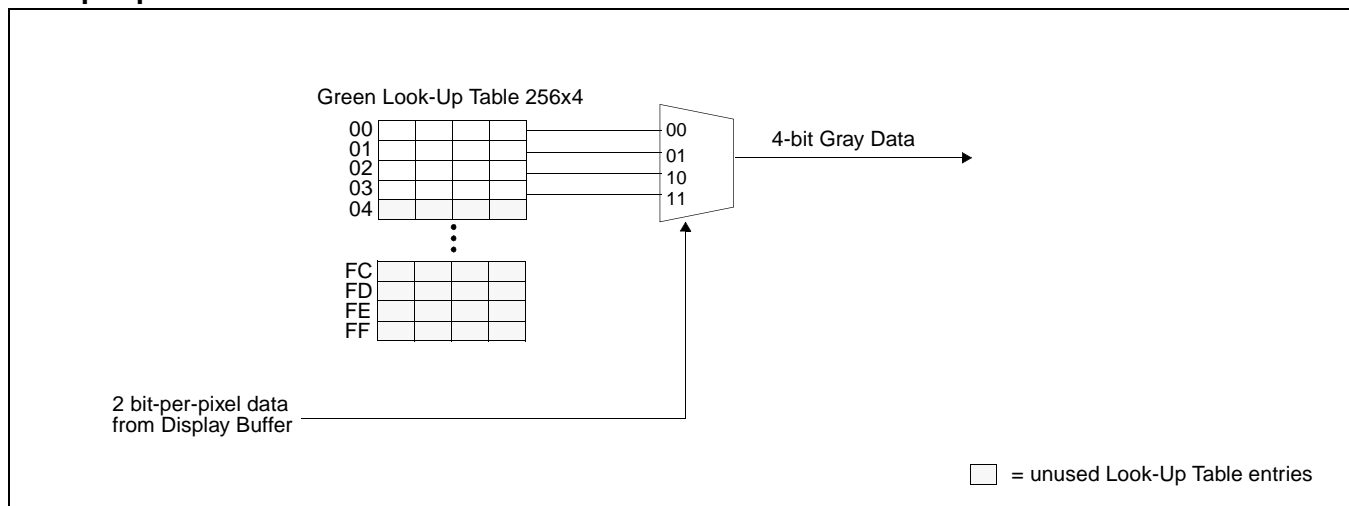

Figure 11-2: 2 Bit-per-pixel Monochrome Mode Data Output Path

### 4 Bit-per-pixel Monochrome Mode

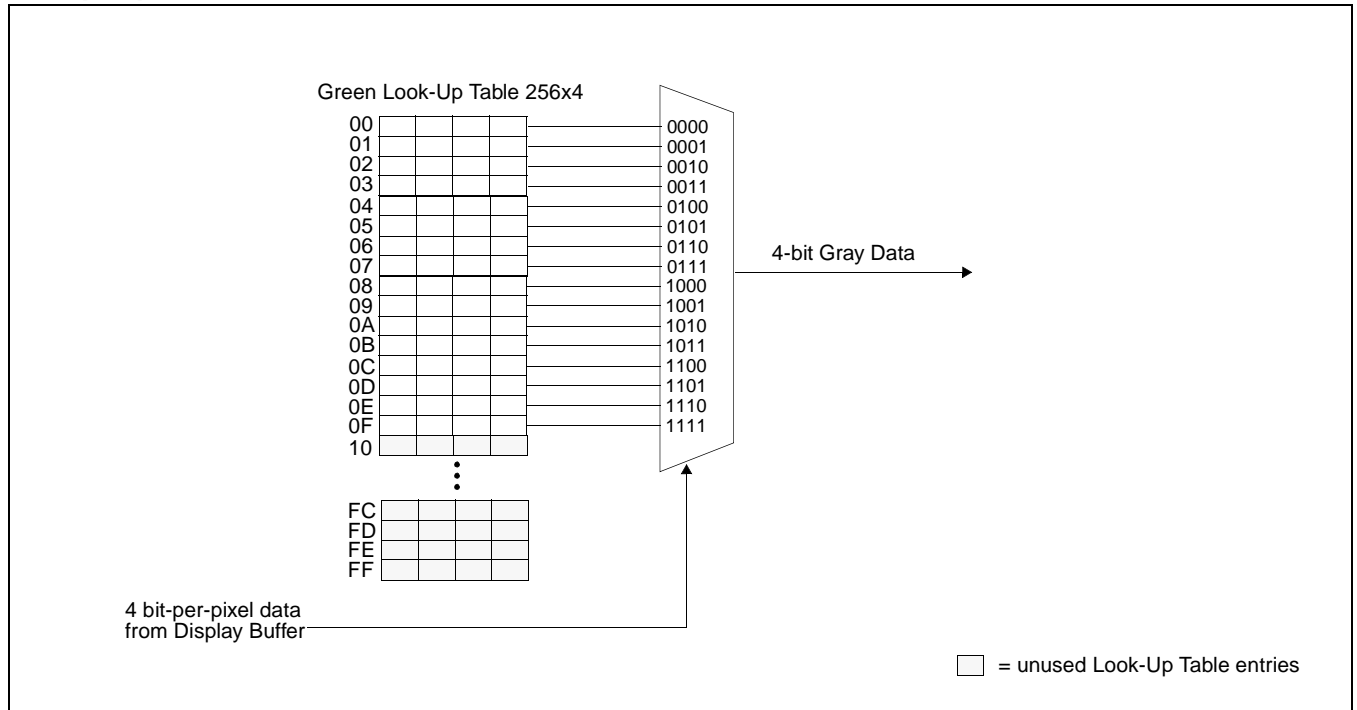

Figure 11-3: 4 Bit-per-pixel Monochrome Mode Data Output Path

## 11.2 Color Modes

### 1 Bit-per-pixel Color Mode

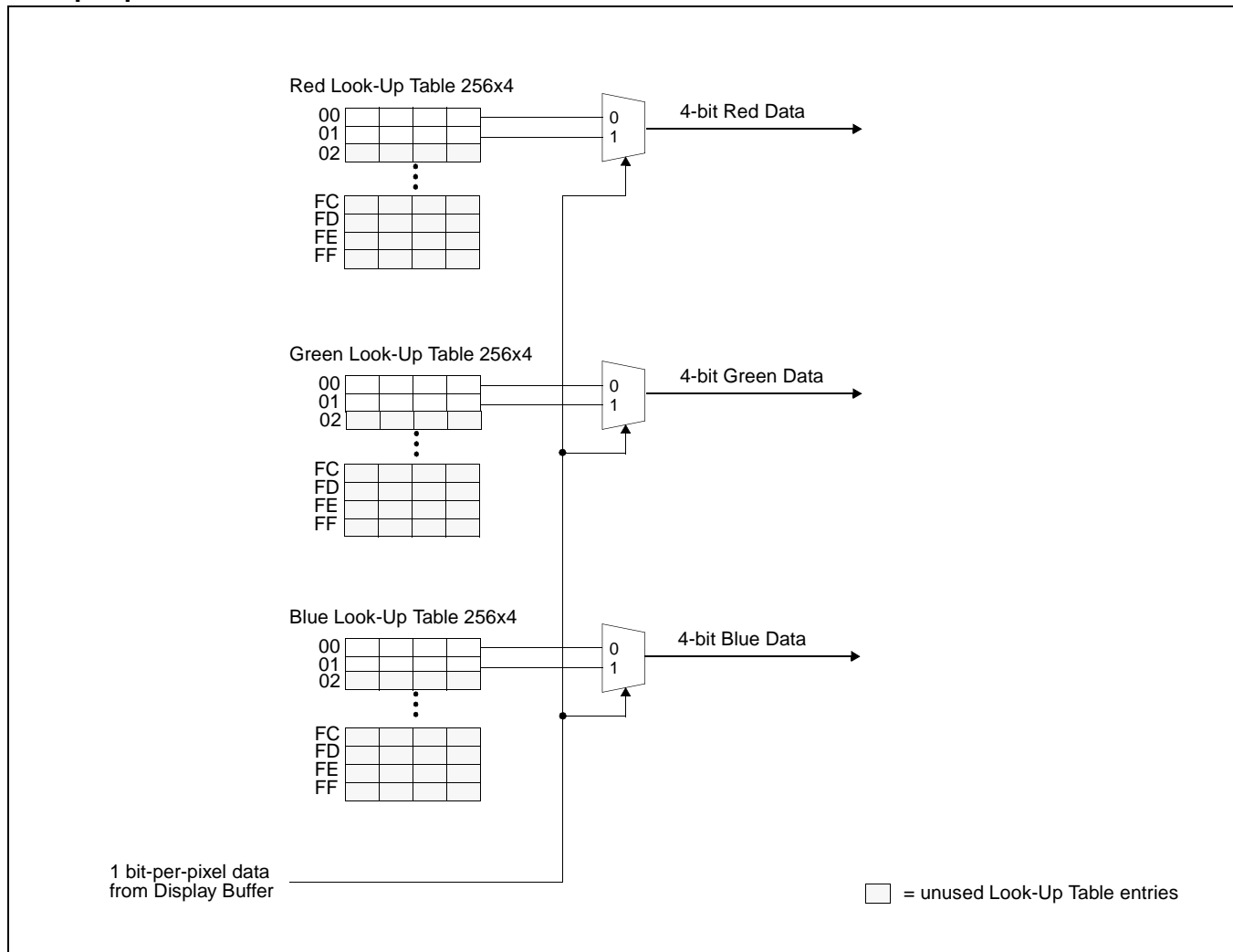

Figure 11-4: 1 Bit-per-pixel Color Mode Data Output Path



## 2 Bit-per-pixel Color Mode

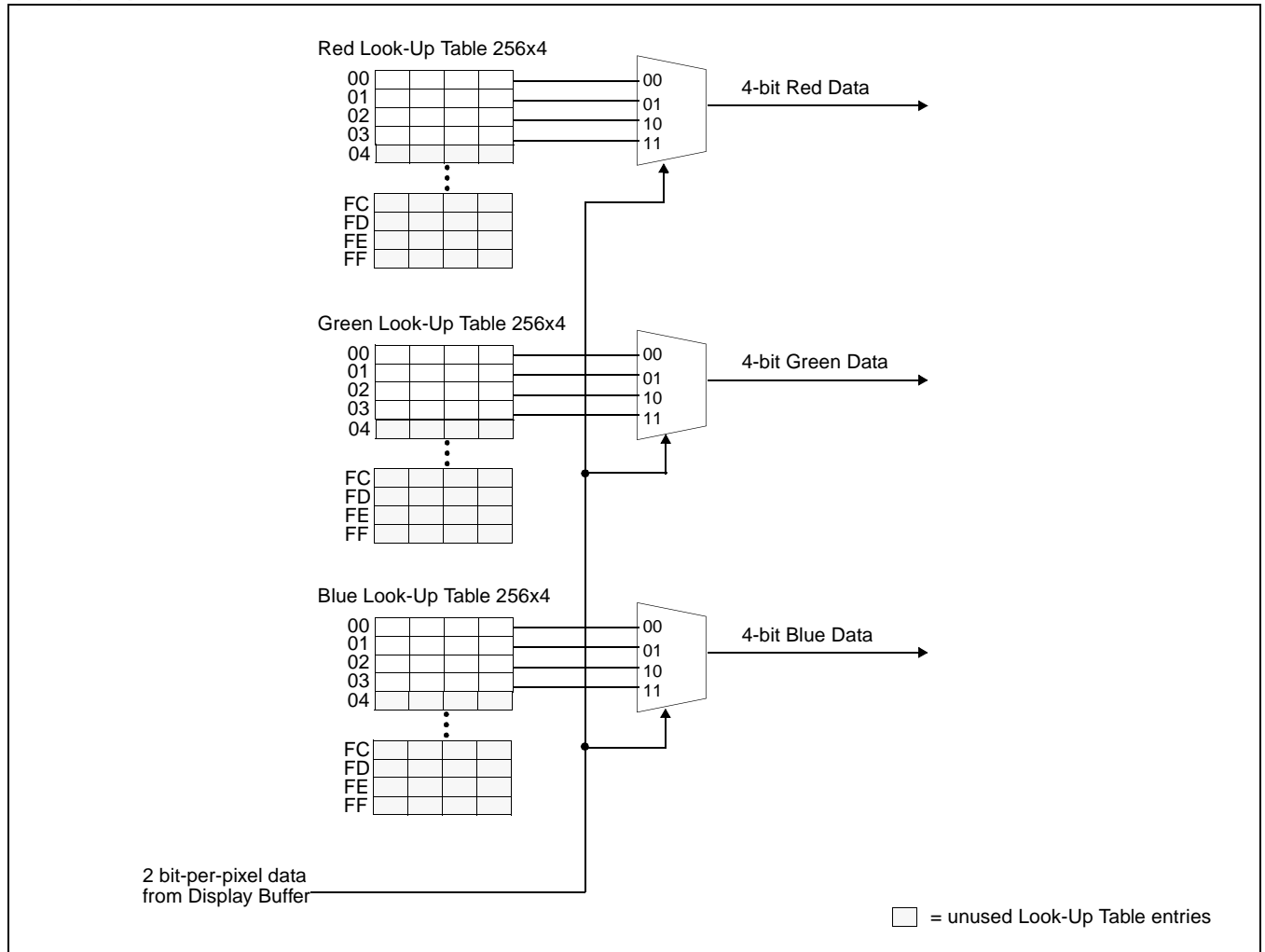

Figure 11-5: 2 Bit-per-pixel Color Mode Data Output Path

### 4 Bit-per-pixel Color Mode

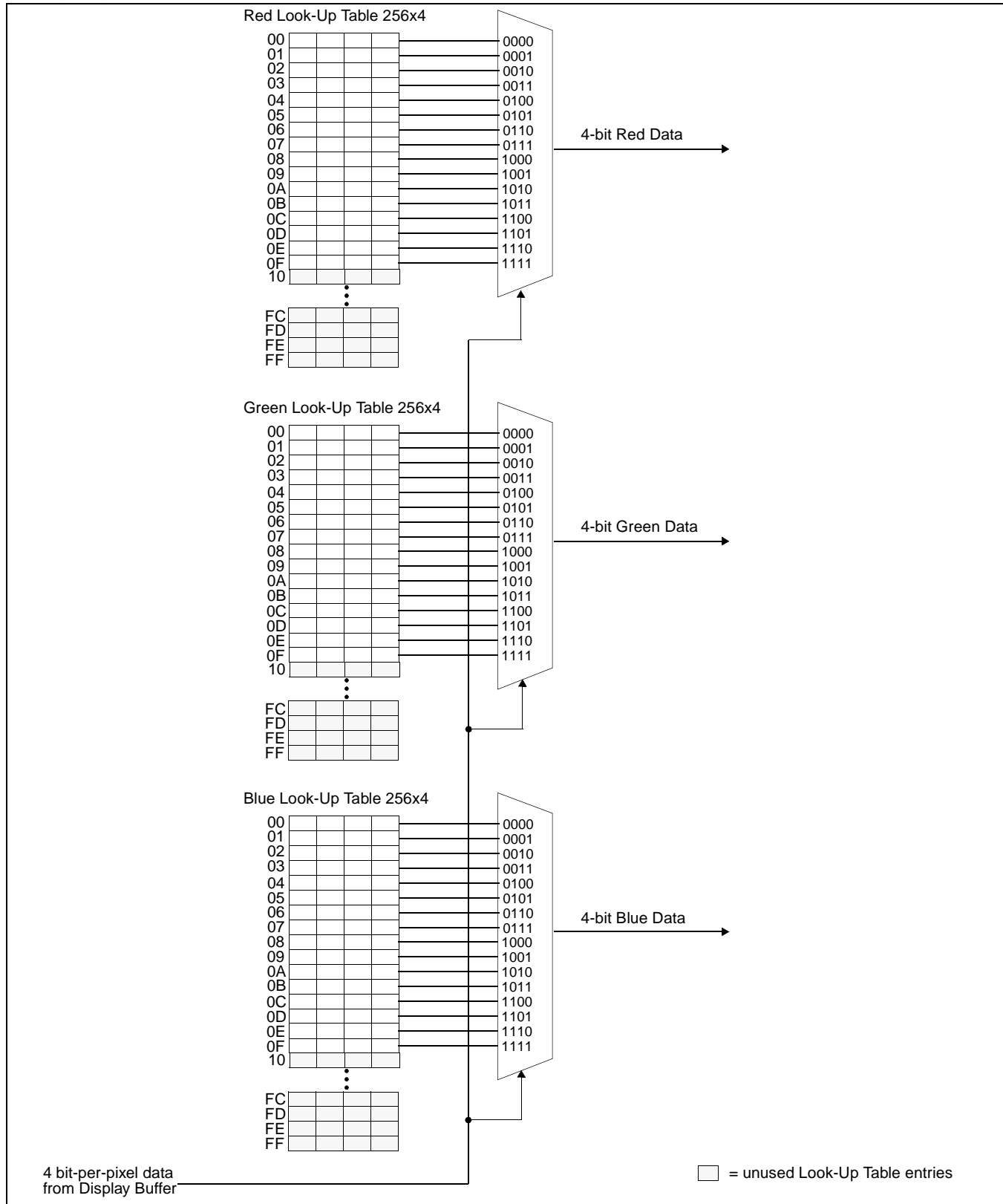

Figure 11-6: 4 Bit-per-pixel Color Mode Data Output Path

### 8 Bit-per-pixel Color Mode

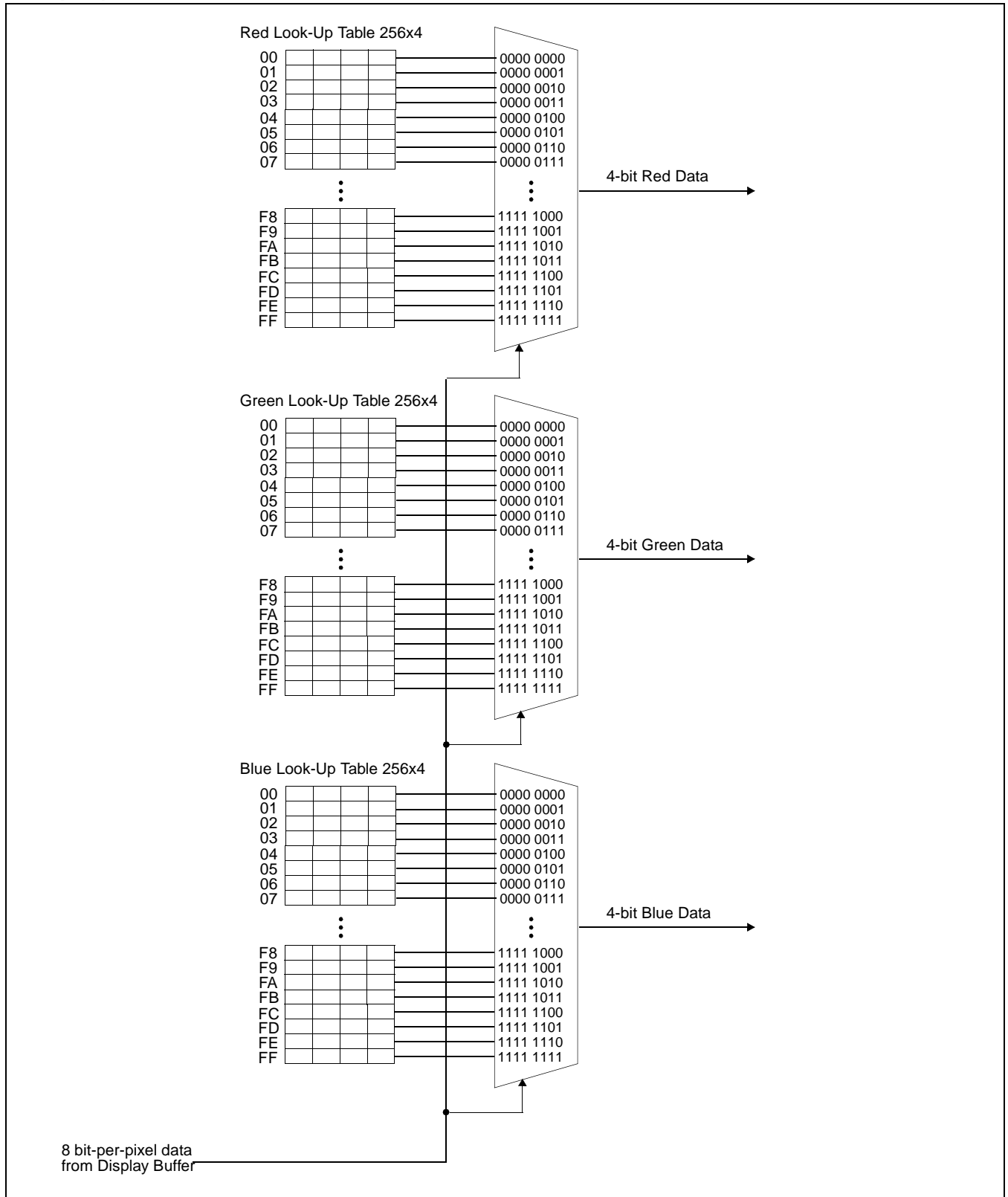

Figure 11-7: 8 Bit-per-pixel Color Mode Data Output Path

## 12 SwivelView™

Many of today's applications use the LCD panel in a portrait orientation. In this case it becomes necessary to "rotate" the displayed image by 90°. This rotation can be done by software at the expense of performance or, it can be done by the SED1375 hardware with no CPU penalty.

There are two SwivelView modes: Default SwivelView Mode and Alternate SwivelView Mode.

### 12.1 Default SwivelView Mode

Default SwivelView Mode requires the SwivelView image width be a power of two, e.g. a 240-line panel requires a minimum virtual image width of 256. This mode should be used whenever the required virtual image can be contained within the integrated display buffer (i.e. virtual image size  $\leq$  80K bytes), as it consumes less power than the Alternate SwivelView Mode.

For example, the panel size is 320x240 and the display mode is 8 bit-per-pixel. The virtual image size is 320x256 which can be contained within the 80K Byte display buffer.

Default SwivelView Mode also requires Memory Clock (MCLK)  $\geq$  Pixel Clock (PCLK).

The following figure shows how the programmer sees a 240x320 image and how the image is displayed. The application image is written to the SED1375 in the following sense: A-B-C-D. The display is refreshed by the SED1375 in the following sense: B-D-A-C.

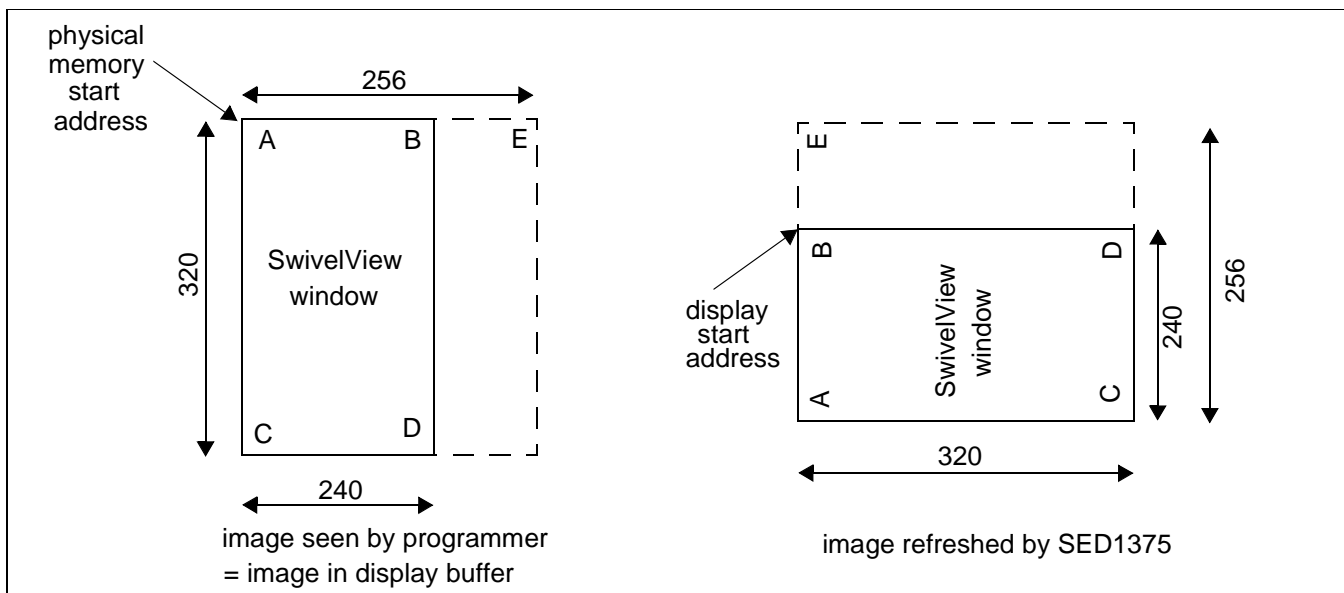

Figure 12-1: Relationship Between The Screen Image and the Image Refreshed by SED1375 in Default Mode

## 12.1.1 How to Set Up Default SwivelView Mode

The following describes the register settings needed to set up Default SwivelView Mode for a 240x320x8 bpp image:

- Select Default SwivelView Mode: REG[1Bh] bit 7 = 1 and bit 6 = 0
- The display refresh circuitry starts at pixel “B”, therefore the Screen 1 Start Address register must be programmed with the address of pixel “B”, i.e.

$$\begin{aligned} \text{REG}[10\text{h}], \text{REG}[0\text{Dh}], \text{REG}[0\text{Ch}] &= \text{AddressOfPixelB} \\ &= (\text{AddressOfPixelA} + \text{ByteOffset}) \\ &= \text{AddressOfPixelA} + \left( \frac{240\text{pixels} \times 8\text{bpp}}{8\text{bpb}} \right) - 1 \\ &= \text{AddressOfPixelA} + \text{EFh} \end{aligned}$$

Where bpp is bits-per-pixel and bpb is bits-per-byte.

- The Line Byte Count Register for SwivelView Mode must be set to the virtual-image width in bytes, i.e.

$$\text{REG}[1\text{Ch}] = \frac{256}{(8\text{bpb}) \div (8\text{bpp})} = \frac{256}{1} = 256 = 00\text{h} \quad \text{:see REG}[1\text{Ch}] \text{ for explanation}$$

Where bpb is bits-per-byte and bpp is bits-per-pixel.

- Panning is achieved by changing the Screen 1 Start Address register:
  - Increment the register by 1 to pan horizontally by one byte, e.g. one pixel in 8 bpp mode
  - Increment the register by twice the effective value of the Line Byte Count register to pan vertically by two lines, e.g. add 200h to pan by two lines in the example above.

### Note

Vertical panning by a single line is not supported in Default SwivelView Mode.

## 12.2 Alternate SwivelView Mode

Alternate SwivelView Mode may be used when the virtual image size of Default SwivelView Mode cannot be contained in the 80K byte integrated frame buffer. For example, the panel size is 480x320 and the display mode is 4 bit-per-pixel. The minimum virtual image size for Default SwivelView Mode would be 480x512 which requires 122,880 bytes. Alternate SwivelView Mode requires a panel size of only 480x320 which needs only 76,800 bytes.

Alternate SwivelView Mode requires the Memory Clock (MCLK) to be at least twice the frequency of the Pixel Clock (PCLK), i.e.  $MCLK \geq 2 \times PCLK$ . This makes the power consumption in Alternate SwivelView Mode higher than in Default SwivelView Mode while increasing performance.

The following figure shows how the programmer sees a 480x320 image and how the image is being displayed. The application image is written to the SED1375 in the following sense: A-B-C-D. The display is refreshed by the SED1375 in the following sense: B-D-A-C.

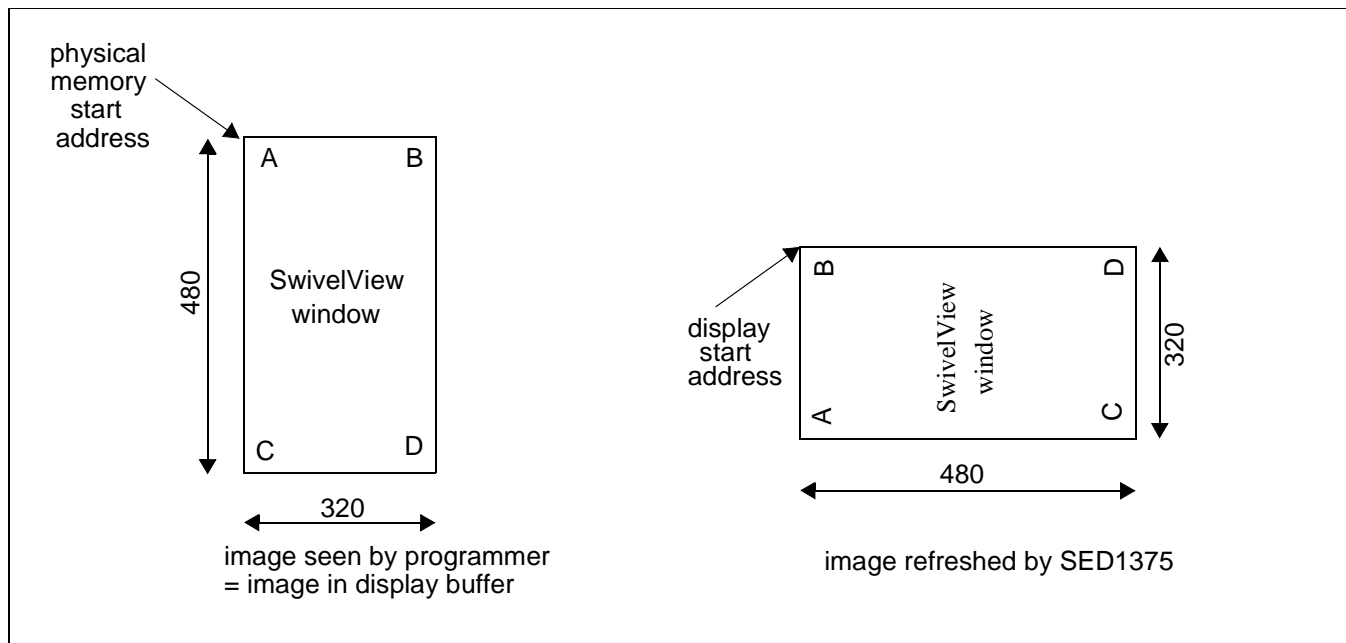

Figure 12-2: Relationship Between The Screen Image and the Image Refreshed by SED1375 in Alternate Mode

## 12.2.1 How to Set Up Alternate SwivelView Mode

The following describes the register settings needed to set up Alternate SwivelView Mode for a 320x480x4 bpp image.

- Select Alternate SwivelView Mode:

REG[1Bh] bit 7 = 1 and bit 6 = 1

- The display refresh circuitry starts at pixel “B”, therefore the Screen 1 Start Address register must be programmed with the address of pixel “B”, or

$$\begin{aligned} \text{REG}[10\text{h}], \text{REG}[0\text{Dh}], \text{REG}[0\text{Ch}] &= \text{AddressOfPixelB} \\ &= (\text{AddressOfPixelA} + \text{ByteOffset}) \\ &= \text{AddressOfPixelA} + \left( \frac{320\text{pixels} \times 4\text{bpp}}{8\text{bpb}} \right) - 1 \\ &= \text{AddressOfPixelA} + 9\text{Fh} \end{aligned}$$

Where bpp is bits-per-pixel and bpb is bits-per-byte.

- The Line Byte Count Register for SwivelView Mode must be set to the image width in bytes, i.e.

$$\text{REG}[1\text{Ch}] = \frac{320}{(8\text{bpb}) \div (4\text{bpp})} = \frac{320}{2} = 160 = \text{A0h}$$

Where bpb is bits-per-byte and bpp is bits-per-pixel.

- Panning is achieved by changing the Screen 1 Start Address register:
  - Increment the register by 1 to pan horizontally by one byte, e.g. two pixels in 4 bpp mode
  - Increment the register by the value in the Line Byte Count register to pan vertically by one line, e.g. add A0h to pan by one line in the example above

## 12.3 Comparison Between Default and Alternate SwivelView Modes

*Table 12-1: Default and Alternate SwivelView Mode Comparison*

Item	Default SwivelView Mode	Alternate SwivelView Mode
Memory Requirements	The width of the rotated image must be a power of 2. In most cases, a virtual image is required where the right-hand side of the virtual image is unused and memory is wasted. For example, a 320x480x4bpp image would normally require only 76,800 bytes - possible within the 80K byte address space, but the virtual image is 512x480x4bpp which needs 122,880 bytes - not possible.	Does not require a virtual image.
Clock Requirements	CLK need only be as fast as the required PCLK.	MCLK, and hence CLK, need to be 2x PCLK. For example, if the panel requires a 3MHz PCLK, then CLK must be 6MHz. Note that 25MHz is the maximum CLK, so PCLK cannot be higher than 12.5MHz in this mode.
Power Consumption	Lowest power consumption.	Higher than Default Mode.
Panning	Vertical panning in 2 line increments.	Vertical panning in 1 line increments.
Performance	Nominal performance.	Higher performance than Default Mode.

## 12.4 SwivelView Mode Limitations

The only limitation to using SwivelView mode on the SED1375 is that split screen operation is not supported.



## 13 Power Save Modes

Two Power Save Modes have been incorporated into the SED1375 to accommodate the need for power reduction in the hand-held devices market. These modes are enabled as follows:

*Table 13-1: Power Save Mode Selection*

Hardware Power Save	Software Power Save Bit 1	Software Power Save Bit 0	Mode
Not Configured or 0	0	0	Software Power Save Mode
Not Configured or 0	0	1	reserved
Not Configured or 0	1	0	reserved
Not Configured or 0	1	1	Normal Operation
Configured and 1	X	X	Hardware Power Save Mode

### 13.1 Software Power Save Mode

Software Power Save Mode saves power by powering down the panel and stopping display refresh accesses to the display buffer.

*Table 13-2: Software Power Save Mode Summary*

• Registers read/write accessible
• Memory read/write accessible
• Look-Up Table registers not accessible
• LCD outputs are forced low

### 13.2 Hardware Power Save Mode

Hardware Power Save Mode saves power by powering down the panel, stopping accesses to the display buffer and registers, and disabling the Host Bus Interface.

*Table 13-3: Hardware Power Save Mode Summary*

• Host Interface not accessible
• Memory read/write not accessible
• Look-Up Table registers not accessible
• LCD outputs are forced low

## 13.3 Power Save Mode Function Summary

Table 13-4: Power Save Mode Function Summary

	Hardware Power Save	Software Power Save	Normal
IO Access Possible?	No	Yes	Yes
Memory Access Possible?	No	Yes	Yes
Look-Up Table Registers Access Possible?	No	No	Yes
Sequence Controller Running?	No	No	Yes
Display Active?	No	No	Yes
LCDPWR	Inactive	Inactive	Active
FPDAT[11:0], FPSHIFT (see note)	Forced Low	Forced Low	Active
FPLINE, FPFRAME, DRDY	Forced Low	Forced Low	Active

### Note

When FPDAT[11:8] are designated as GPIO outputs, the output state prior to enabling the Power Save Mode is maintained. When FPDAT[11:8] are designated as GPIO inputs, unused inputs must be tied to either IO  $V_{DD}$  or GND - see Table 5.5 “LCD Interface Pin Mapping,” on page 23.

## 13.4 Panel Power Up/Down Sequence

After chip reset or when entering/exiting a power save mode, the Panel Interface signals follow a power on/off sequence shown below. This sequence is essential to prevent damage to the LCD panel.

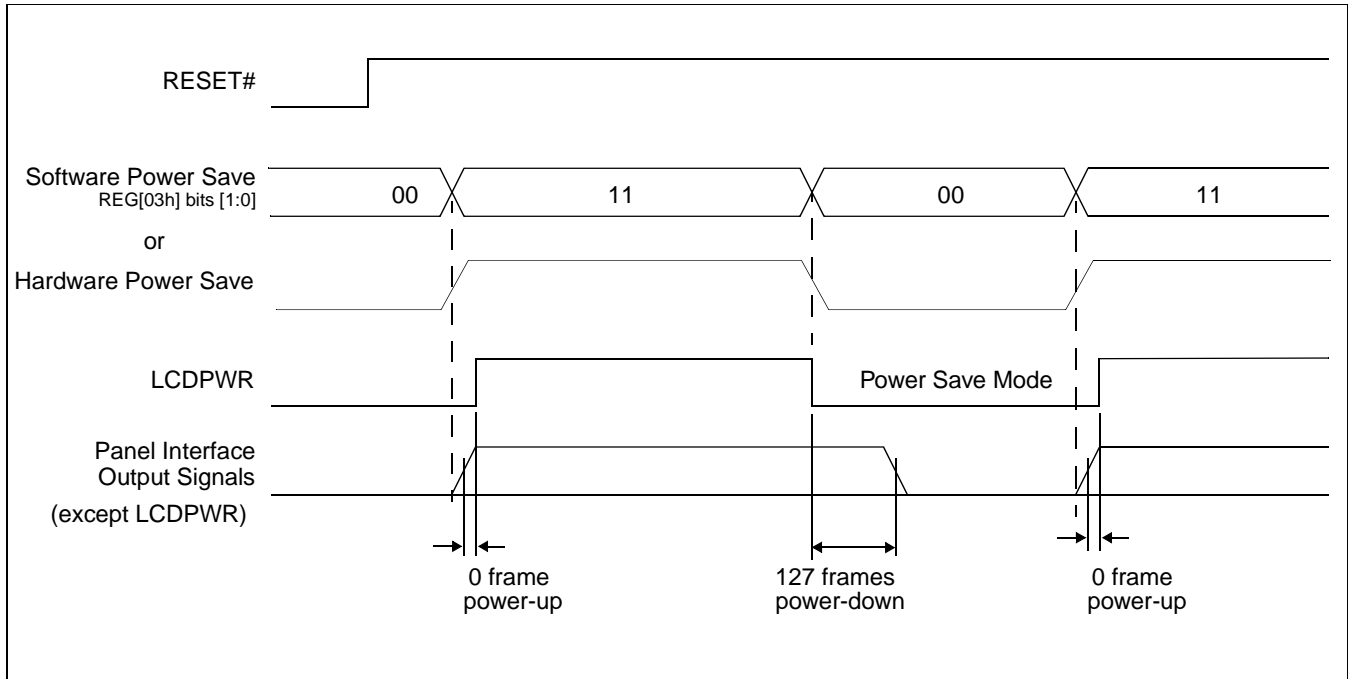

Figure 13-1: Panel On/Off Sequence

After chip reset, LCDPWR is inactive and the rest of the panel interface output signals are held “low”. Software initializes the chip (i.e. programs all registers except the Look-Up Table registers) and then programs REG[03h] bits [1:0] to 11b. This starts the power-up sequence as shown. The power-up/power-down sequence delay is 127 frames. The Look-Up Table registers may be programmed any time after REG[03h] bits[1:0] = 11b.

The power-up/power-down sequence also occurs when exiting/entering Software Power Save Mode.

### 13.5 Turning Off BCLK Between Accesses

BCLK may be turned off (held low) between accesses if the following rules are observed:

1. BCLK must be turned off/on in a glitch free manner
2. BCLK must continue for a period equal to  $[8T_{BCLK} + 12T_{MCLK}]$  after the end of the access (RDY# asserted or WAIT# deasserted).
3. BCLK must be present for at least one  $T_{BCLK}$  before the start of an access.

## 13.6 Clock Requirements

The following table shows what clock is required for which function in the SED1375

*Table 13-5: SED1375 Internal Clock Requirements*

Function	BCLK	CLKI
Register Read/Write	Is required during register accesses. BCLK can be shut down between accesses: allow eight BCLK pulses plus 12 MCLK pulses ( $8T_{BCLK} + 12T_{MCLK}$ ) after the last access before shutting BCLK off. Allow one BCLK pulse after starting up BCLK before the next access	Not Required
Memory Read/Write	Is required during memory accesses. BCLK can be shut down between accesses: allow eight BCLK pulses plus 12 MCLK pulses ( $8T_{BCLK} + 12T_{MCLK}$ ) after the last access before shutting BCLK off. Allow one BCLK pulse after starting up BCLK before the next access	Required
Look-Up Table Register Read/Write	Is required during LUT register accesses. BCLK can be shut down between accesses: allow eight BCLK pulses plus 12 MCLK pulses ( $8T_{BCLK} + 12T_{MCLK}$ ) after the last access before shutting BCLK off. Allow one BCLK pulse after starting up BCLK before the next access	Not Required
Software Power Save	Required	Can be stopped after 128 frames from entering Software Power Save, i.e. after REG[03h] bits 1-0 = 11
Hardware Power Save	Not Required	Can be stopped after 128 frames from entering Hardware Power Save



**THIS PAGE LEFT BLANK**



## **SED1375 Embedded Memory LCD Controller**

# **Programming Notes and Examples**

**Document Number: X27A-G-002-01**

Copyright © 1999 Epson Research and Development, Inc. All Rights Reserved.

Information in this document is subject to change without notice. You may download and use this document, but only for your own use in evaluating Seiko Epson/EPSON products. You may not modify the document. Epson Research and Development, Inc. disclaims any representation that the contents of this document are accurate or current. The Programs/Technologies described in this document may contain material protected under U.S. and/or International Patent laws.

EPSON is a registered trademark of Seiko Epson Corporation. All other Trademarks are the property of their respective owners

---

**THIS PAGE LEFT BLANK**



# Table of Contents

<b>1</b>	<b>Introduction</b>	<b>7</b>
<b>2</b>	<b>Initialization</b>	<b>8</b>
2.1	Display Buffer Location	8
2.2	Register Values	8
2.3	Frame Rate Calculation	9
<b>3</b>	<b>Memory Models</b>	<b>12</b>
3.1	1 Bit-Per-Pixel (2 Colors/Gray Shades)	12
3.2	2 Bit-Per-Pixel (4 Colors/Gray Shades)	13
3.3	4 Bit-Per-Pixel (16 Colors/Gray Shades)	13
3.4	Eight Bit-Per-Pixel (256 Colors)	14
<b>4</b>	<b>Look-Up Table (LUT)</b>	<b>15</b>
4.1	Look-Up Table Registers	16
4.2	Look-Up Table Organization	17
4.2.1	Color Modes	17
4.2.2	Gray Shade Modes	22
<b>5</b>	<b>Advanced Techniques</b>	<b>25</b>
5.1	Virtual Display	25
5.1.1	Registers	26
5.1.2	Examples	26
5.2	Panning and Scrolling	27
5.2.1	Registers	28
5.2.2	Examples	29
5.3	Split Screen	31
5.3.1	Registers	32
5.3.2	Examples	34
<b>6</b>	<b>LCD Power Sequencing and Power Save Modes</b>	<b>35</b>
6.1	LCD Power Sequencing	35
6.2	Registers	35
6.3	LCD Enable/Disable	36
<b>7</b>	<b>Hardware Rotation</b>	<b>37</b>
7.1	Introduction To Hardware Rotation	37
7.2	Default Portrait Mode	37
7.3	Alternate Portrait Mode	39
7.4	Registers	40
7.5	Limitations	42
7.6	Examples	43

---

<b>8</b>	<b>Identifying the SED1375</b>	<b>.47</b>
<b>9</b>	<b>Hardware Abstraction Layer (HAL)</b>	<b>.48</b>
9.1	Introduction	.48
9.2	Contents of the HAL_STRUCT	.48
9.3	Using the HAL library	.49
9.4	API for 1375HAL	.49
9.4.1	Initialization	51
9.4.2	General HAL Support	52
9.4.3	Advanced HAL Functions	55
9.4.4	Register / Memory Access	58
9.4.5	Power Save	60
9.4.6	Drawing	61
9.4.7	LUT Manipulation	62
9.5	Porting LIBSE to a new target platform	.64
9.5.1	Building the LIBSE library for SH3 target example	65
9.5.2	Building the HAL library for the target example	65
<b>10</b>	<b>Sample Code</b>	<b>.66</b>
10.1	Sample code using the SED1375 HAL API	.66
10.2	Sample code without using the SED1375 HAL API	.68
10.3	Header Files	.77

## List of Tables

Table 2-1: SED1375 Initialization Sequence . . . . .	9
Table 4-1: Recommended LUT Values for 1 Bpp Color Mode . . . . .	17
Table 4-2: Example LUT Values for 2 Bpp Color Mode . . . . .	18
Table 4-3: Suggested LUT Values to Simulate VGA Default 16 Color Palette . . . . .	19
Table 4-4: Suggested LUT Values to Simulate VGA Default 256 Color Palette . . . . .	20
Table 4-5: Recommended LUT Values for 1 Bpp Gray Shade . . . . .	22
Table 4-6: Suggested Values for 2 Bpp Gray Shade . . . . .	23
Table 4-7: Suggested LUT Values for 4 Bpp Gray Shade . . . . .	24
Table 5-1: Number of Pixels Panned Using Start Address . . . . .	28
Table 7-1: Default and Alternate Portrait Mode Comparison . . . . .	42
Table 9-1: HAL Functions . . . . .	49

## List of Figures

Figure 3-1: Pixel Storage for 1 Bpp (2 Colors/Gray Shades) in One Byte of Display Buffer . . . . .	12
Figure 3-2: Pixel Storage for 2 Bpp (4 Colors/Gray Shades) in One Byte of Display Buffer . . . . .	13
Figure 3-3: Pixel Storage for 4 Bpp (16 Colors/Gray Shades) in One Byte of Display Buffer . . . . .	13
Figure 3-4: Pixel Storage for 8 Bpp (256 Colors) in One Byte of Display Buffer . . . . .	14
Figure 5-1: Viewport Inside a Virtual Display . . . . .	25
Figure 5-2: 320x240 Single Panel For Split Screen . . . . .	31
Figure 7-1: Relationship Between the Default Mode Screen Image and the Image Refreshed by SED1375 . . . . .	38
Figure 7-2: Relationship Between the Alternate Mode Screen Image and the Image Refreshed by SED1375 . . . . .	39

**THIS PAGE LEFT BLANK**

# 1 Introduction

This guide demonstrates how to program the SED1375 Embedded Memory Color LCD Controller. The guide presents the basic concepts of the LCD controller and provides methods to directly program the registers. It explains some of the advanced techniques used and the special features of the SED1375.

The guide also introduces the Hardware Abstraction Layer (HAL), which is designed to make programming the SED1375 as easy as possible. Future SED137x products will support the HAL allowing OEMs the ability to upgrade to future chips with relative ease.

## 2 Initialization

Prior to doing anything else with the SED1375 the controller must be initialized. Initialization is the process of setting up the control registers to a known state in order to generate proper display signals.

### 2.1 Display Buffer Location

Before we can perform the initialization we have to know where to find the SED1375 display memory and control registers.

The SED1375 contains 80 kilobytes of internal display memory. External support logic must be employed to decode the starting address for this display memory in CPU address space. On the SDU1375B0x PC platform evaluation boards the address is usually fixed at F00000h. Alternatively the address can be set to D0000h.

The control registers are located by adding 1FFE0h (128 Kb less 32 bytes) to the base memory address. Thus, on the typical PC platform, we access control register 0 at address F1FFE0h. Control register 5 would be located at address F1FFE5, etc.

### 2.2 Register Values

This section describes the register settings and sequence of setting the registers. In addition to these setting the Look-Up Table must be programmed with appropriate colors. Look-Up Table setup is not covered here. See Section 4 on page 15 of this manual for Look-Up Table programming details.

The following initialization, presented in table form, shows the sequences and values to set the registers. The notes column comments the reason for the particular value being written.

This example writes to all the necessary registers. Initially, when the SED1375 is powered up, all registers, unless noted otherwise in the specification, are set to zero. This example programs these registers to zero to establish a known state. In practice, it may be possible to write to only a subset of the registers.

The example initializes a SED1375 to control a panel with the following specifications:

- 320x240 color single passive LCD panel at 70Hz.
- Color Format 2, 8-bit data interface.
- 8 bit-per-pixel (256 colors).
- 6 MHz input clock (CLKI).

Table 2-1: SED1375 Initialization Sequence

Register	Value (hex)	Notes	See Also
[01]	0010 0011 (23)	Select a passive, Single, Color panel with an 8-bit data width	
[02]	1100 0000 (C0)	Select 8-bit per pixel color depth	
[03]	0000 0011 (03)	Select normal power operation	
[04]	0010 0111 (27)	Horizontal display size = (Reg[04]+1)*8 = (39+1) * 8 = 320 pixels	
[05]	1110 1111 (EF)	Vertical display size = Reg[06][05] + 1	
[06]	0000 0000 (00)	= 0000 0000 1110 1111 + 1 = 239 +1 = 240 lines	
[07]	0000 0000 (00)	FPLINE start position (only required for TFT configuration)	
[08]	0000 0000 (00)	Horizontal non-display period = (Reg[08] + 4) * 8 = 4 * 8 = 32 pixels	Frame Rate Calculation
[09]	0000 0000 (00)	FPFRAME start position (only required for TFT configuration)	
[0A]	0000 0011 (03)	Vertical non-display period = REG[0A] = 3 lines	Frame Rate Calculation
[0B]	0000 0000 (00)	MOD rate is only required by some monochrome panels	
[0C]	0000 0000 (00)	Screen 1 Start Address - set to 0 for initialization	Split Screen on page 31
[0D]	0000 0000 (00)		
[0E]	0000 0000 (00)	Screen 2 Start Address - set to 0 for initialization	Split Screen on page 31
[0F]	0000 0000 (00)		
[10]	0000 0000 (00)	Screen 1 / Screen 2 Start Address MSB - set to 0	
[11]	0000 0000 (00)	Memory Address offset - not virtual setup - so set to 0	Virtual Display on page 25
[12]	1111 1111 (FF)	Set the vertical size to the maximum value.	Split Screen on page 31
[13]	0000 0011 (03)		
[15]		Leave the LUT alone for now	Look-Up Table (LUT) on page 15
[17]			
[18]	0000 0000 (00)	GPIO control and status registers - set to "0".	
[19]	0000 0000 (00)		
[1A]	0000 0000 (00)	Set the scratch pad bits to "0".	
[1B]	0000 0000 (00)	This is not portrait mode so set this register to "0".	Introduction To Hardware Rotation on page 37
[1C]	0000 0000 (00)	Line Byte Count is only required for portrait mode.	

## 2.3 Frame Rate Calculation

Frame rate specifies the number of complete frame which are drawn on the display in one second. Configuring a frame rate that is too high or too low adversely effects the quality of the displayed image.

System configuration imposes certain non-variable limitations. For instance the width and height of the display panel are fixed as is, typically, the input clock to the SED1375. From the following formula it is evident that the two variables the programmer can use to adjust frame rate are horizontal and vertical non-display periods.

The following are the formulae for determining the frame rate of a panel. The formula for a single passive or TFT panel is calculated as follows:

$$\text{FrameRate} = \frac{\text{PCLK}}{(\text{HDP} + \text{HNDP}) \times (\text{VDP} + \text{VNDP})}$$

for a dual passive panel the formula is:

$$\text{FrameRate} = \frac{\text{PCLK}}{2 \times (\text{HDP} + \text{HNDP}) \times \left(\frac{\text{VDP}}{2} + \text{VNDP}\right)}$$

where: PCLK = Pixel clock (in Hz)  
 HDP = Horizontal Display Period (in pixels)  
 HNDP = Horizontal Non-Display Period (in pixels)  
 VDP = Vertical Display Period (in lines)  
 VNDP = Vertical Non-Display Period (in lines)

In addition to varying the HNDP and VNDP times we can also select divider values which will reduce CLKi to one half, one quarter up to one eighth of the CLKi value. The example below is a portion of a 'C' routine to calculate HNDP and VNDP from a desired frame rate.

```
for (int loop = 0; loop < 2; loop++)
{
    for (VNDP = 2; VNDP < 0x3F; VNDP += 3)
    {
        // Solve for HNDP
        HNDP = (PCLK / (FrameRate * (VDP + VNDP))) - HDP;
        if ((HNDP >= 32) && (HNDP <= 280))
        {
            // Solve for VNDP.
            VNDP = (PCLK / (FrameRate * (HDP + HNDP))) - VDP;
            // If we have satisfied VNDP then we're done.
            if ((VNDP >= 0) && (VNDP <= 0x3F))
                goto DoneCalc;
        }
    }
    // Divide ClkI and try again.
    // (Reg[02] allows us to dived CLKI by 2)
    PCLK /= 2;
}
// If we still can't hit the frame rate - throw an error.
if ((VNDP < 0) || (VNDP > 0x3F) || (HNDP < 32) || (HNDP > 280))
{
    sprintf("ERROR: Unable to set the desired frame rate.\n");
    exit(1);
}
```



This routine first performs a formula rearrangement so that HNBP or VNBP can be solved. Start with VNBP set to a small value. Loop increasing VNBP and solving the equation for HNBP until satisfactory HNBP and VNBP values are found. If no satisfactory values are found then divide CLKI and repeat the process. If a satisfactory frame rate still can't be reached - return an error.

**Note**

Most passive (STN) panels are tolerant of nearly any combination of HNBP and VNBP values, however panel specifications generally specify only a few lines of vertical non-display period. The SED1375 is capable of generating a vertical non-display period of up to sixty-three lines. This amount of VNBP is far too great a non-display period and will likely degrade display quality. Similarly, setting a large HNBP value may cause a degrade in image quality.

If possible the system should be designed such that VNBP values of 7 or less lines and HNBP values of 20 or less characters can be selected.

## 3 Memory Models

The SED1375 is capable of operating at four different color depths. For each color depth the data format is packed pixel. SED1375 packed pixel modes can range from one byte containing eight adjacent pixels (1-bpp) to one byte containing just one pixel (8-bpp).

Packed pixel data may be envisioned as a stream of pixels. In this stream, pixels are packed in adjacent to each other. If a pixel requires four bits then it will be located in the four most significant bits of a byte. The pixel to the immediate right on the display will occupy the lower four bits of the same byte. The next two pixels to the immediate right are located in the following byte, etc.

### 3.1 1 Bit-Per-Pixel (2 Colors/Gray Shades)

1-bit pixels support two color/gray shades. In this memory format each byte of display buffer contains eight adjacent pixels. Setting or resetting any pixel requires reading the entire byte, masking out appropriate bits and, if necessary, setting bits to “1”.

When using a color panel the two colors are derived by indexing into positions 0 and 1 of the Look-Up Table. If the first two LUT elements are set to black (RGB = 0 0 0) and white (RGB = F F F) then each “0” bit of display memory will display as a black pixel and each “1” bit will display as a white pixel. The two LUT entries can be set to any desired colors, for instance red and green or cyan and yellow.

For monochrome panels the two displayed gray shades are generated by indexing into the first two elements of the green component of the Look-Up Table (LUT). Thus, by manipulating the green LUT components we can set either of the two gray shades to any of sixteen possible levels.

Bit 7	Bit 6	Bit 5	Bit 4	Bit 3	Bit 2	Bit 1	Bit 0
Pixel 0	Pixel 1	Pixel 2	Pixel 3	Pixel 4	Pixel 5	Pixel 6	Pixel 7

*Figure 3-1: Pixel Storage for 1 Bpp (2 Colors/Gray Shades) in One Byte of Display Buffer*

### 3.2 2 Bit-Per-Pixel (4 Colors/Gray Shades)

2-bit pixels support four color/gray shades. In this memory format each byte of display buffer contains four adjacent pixels. Setting or resetting any pixel requires reading the entire byte, masking out the appropriate bits and, if necessary, setting bits to “1”.

Color panels derive their four colors by indexing into positions 0 through 3 of the Look-Up Table. These four LUT entries can be set to any of the 4096 possible color combinations.

Monochrome panels derive four gray shades by indexing into the first four elements of the green component of the Look-Up Table. Any of the four LUT entries can be set to any of the sixteen possible gray shades.

Bit 7	Bit 6	Bit 5	Bit 4	Bit 3	Bit 2	Bit 1	Bit 0
Pixel 0 Bit 1	Pixel 0 Bit 0	Pixel 1 Bit 1	Pixel 1 Bit 0	Pixel 2 Bit 1	Pixel 2 Bit 0	Pixel 3 Bit 1	Pixel 3 Bit 0

Figure 3-2: Pixel Storage for 2 Bpp (4 Colors/Gray Shades) in One Byte of Display Buffer

### 3.3 4 Bit-Per-Pixel (16 Colors/Gray Shades)

Four bit pixels support 16 color/gray shades. In this memory format each byte of display buffer contains two adjacent pixels. Setting or resetting any pixel requires reading the entire byte, masking out the upper or lower nibble (4 bits) and setting the appropriate bits to “1”.

Color panels can display up to sixteen colors simultaneously. These sixteen colors are derived by indexing into the first sixteen elements of the Look-Up Table. Each of these colors may be selected from the 4096 possible available colors.

On a monochrome panel the gray shades are generated by indexing into the first sixteen green components of the LUT. Each of these sixteen possible gray shades can be adjusted to any of the sixteen possible gray shades. For instance, one could program the first eight green LUT entries to be 0 and the second green LUT entries to be FFh. This would result in nibble values of 0 through 7 displaying as black and nibble values 8 through 0Fh displaying as white.

Bit 7	Bit 6	Bit 5	Bit 4	Bit 3	Bit 2	Bit 1	Bit 0
Pixel 0 Bit 3	Pixel 0 Bit 2	Pixel 0 Bit 1	Pixel 0 Bit 0	Pixel 1 Bit 3	Pixel 1 Bit 2	Pixel 1 Bit 1	Pixel 1 Bit 0

Figure 3-3: Pixel Storage for 4 Bpp (16 Colors/Gray Shades) in One Byte of Display Buffer

### 3.4 Eight Bit-Per-Pixel (256 Colors)

In eight bit-per-pixel mode one byte of display buffer represents one pixel on the display. At this color depth the read-modify-write cycles, required by the lesser pixel depths, are eliminated.

When using a color panel, each byte of display memory acts as an index to one element of the LUT. The displayed color is arrived at by taking the display memory value as an index into the LUT.

Eight bit per pixel is not supported for monochrome display modes. The reason is that each element of the LUT supports a 4-bit (sixteen value) level for red, green and blue. In monochrome display modes on the green value is used to set the gray intensity. Thus we have sixteen possible grey values but, because of the color

Bit 7	Bit 6	Bit 5	Bit 4	Bit 3	Bit 2	Bit 1	Bit 0
Red bit 2	Red bit 1	Red bit 0	Green bit 2	Green bit 1	Green bit 0	Blue bit 1	Blue bit 0

*Figure 3-4: Pixel Storage for 8 Bpp (256 Colors) in One Byte of Display Buffer*

## 4 Look-Up Table (LUT)

This section is supplemental to the description of the Look-Up Table architecture found in the SED1375 Hardware Functional Specification. Covered here is a review of the LUT registers, recommendations for the color and gray shade LUT values, and additional programming considerations for the LUT. Refer to the SED1375 Hardware Functional Specification, document number X27A-A-001-xx for more detail.

The SED1375 Look-Up Table consists of 256 indexed red/green/blue entries. Each entry is 4 bits wide. Two registers, REG[15h] and REG[17h], control access to the LUT.

Each Look-Up Table entry consists of a red, green, and blue component. Each component consisting of four bits, or sixteen intensity levels. Any Look-Up Table element can be selected from a palette of 4096 (16x16x16) colors.

In color display modes, pixel values are used as an index to an RGB value stored in the Look-Up Table. In monochrome modes, pixel values still index into the LUT, but only the green component is used to determine display intensity.

The selected color depth determines how many index positions are used for image display. For example at one bit-per-pixel (bpp) only index positions 0 and 1 of the Look-Up Table are used. At 4-bpp the first 16 index positions of the Look-Up Table are used and at 8-bpp all 256 Look-Up Table index positions are used.

The Look-Up Table mechanism itself consists of an index register and a data register. The index, or address, register determines which element of the Look-Up Table will be accessed. After setting the index the LUT may be read or written through the data register. The first data element read or written is the red component of the entry. Subsequent read/write operations access the green and then the blue elements of the Look-Up Table.

The SED1375 LUT architecture is designed to provide a high degree of similarity in operation to a standard VGA RAMDAC. However, there are two considerations which must be kept in mind.

- The SED1375 Look-Up Table has four bits (16 levels) of intensity per primary color. The standard VGA RAMDAC has six bits (64 levels). This four to one difference must be taken into consideration when converting from a VGA palette to a LUT palette. One suggestion is to divide the VGA intensity level by four to arrive at the LUT intensity.

However, most applications specify the red, green and blue components as eight bit intensities. To determine the appropriate SED1375 Look-Up Table value we recommend using the four most significant bits.

## 4.1 Look-Up Table Registers

REG[15h] Look-Up Table Address Register							Read/Write
LUT Address Bit 7	LUT Address Bit 6	LUT Address Bit 5	LUT Address Bit 4	LUT Address Bit 3	LUT Address Bit 2	LUT Address Bit 1	LUT Address Bit 0

### LUT Address

The LUT address register selects which of the 256 LUT entries will be accessed. After three successive reads/writes to the data register this register is automatically incremented to point to the next address.

REG[17h] Look-Up Table Data Register							Read/Write
LUT Data Bit 3	LUT Data Bit 2	LUT Data Bit 1	LUT Data Bit 0	n/a	n/a	n/a	n/a

### LUT Data

This register is where the 4-bit red/green/blue data value is written/read. Immediately after setting the LUT index with register [15h] this register accesses the red element of the Look-Up Table. With each successive write/read the internal bank select is incremented. Thus the second access is from the green element and the third is from the blue element.

After the third access the LUT Address is incremented by one, then next access to this register will be the red element of the next Look-Up Table index.

## 4.2 Look-Up Table Organization

### 4.2.1 Color Modes

#### 1 bpp color

When the SED1375 is configured for 1 bpp color mode, the LUT is limited to selecting colors from the first two entries. The two LUT entries can be any two RGB values but are typically set to black-and-white.

Each byte in the display buffer contains eight adjacent pixels. If a bit has a value of “0” then the color in LUT 0 index is displayed. A bit value of “1” results in the color in LUT 1 index being displayed.

The following table shows the recommended values for obtaining a black-and-white mode while in 1 bpp on a color panel.

*Table 4-1: Recommended LUT Values for 1 Bpp Color Mode*

Index	Red	Green	Blue
00	00	00	00
01	F0	F0	F0
02	00	00	00
...	00	00	00
FF	00	00	00
	unused entries		

## 2 bpp color

When the SED1375 is configured for 2 bpp color mode, the displayed colors are selected from the first four entries of the Look-Up Table. The LUT entries may be set to any of the 4096 possible colors.

Each byte in the display buffer contains four adjacent pixels. If a bit combination has a value of “00” then the color in LUT index 0 is displayed. A bit value of “01” results in the color in LUT index 1 being displayed. Likewise the bit combination of “10” displays from the third LUT entry and “11” displays a color from the fourth LUT entry.

The following table shows the example values for 2 bit-per-pixel display mode.

*Table 4-2: Example LUT Values for 2 Bpp Color Mode*

Index	Red	Green	Blue
00	00	00	00
01	70	70	70
02	A0	A0	A0
03	F0	F0	F0
04	00	00	00
...	00	00	00
FF	00	00	00

	indicates unused entries
--	--------------------------



### 4 bpp color

When the SED1375 is configured for 4 bpp color mode, the displayed colors are selected from the first sixteen entries of the Look-Up Table. The LUT entries may be set to any of the 4096 possible colors.

Each byte in the display buffer contains two adjacent pixels. If a nibble has a value of “0000” then the color in LUT index 0 is displayed. A nibble value of “0001” results in the color in LUT index 1 being displayed. The pattern continues to the nibble pattern of “1111” which results in the sixteenth color of the Look-Up Table being displayed.

The following table shows the example values for 4 bit-per-pixel display mode. These colors simulate the colors used by the sixteen color modes of a VGA.

*Table 4-3: Suggested LUT Values to Simulate VGA Default 16 Color Palette*

Index	Red	Green	Blue
00	00	00	00
01	00	00	A0
02	00	A0	00
03	00	A0	A0
04	A0	00	00
05	A0	00	A0
06	A0	A0	00
07	A0	A0	A0
08	00	00	00
09	00	00	F0
0A	00	F0	00
0B	00	F0	F0
0C	F0	00	00
0D	F0	00	F0
0E	F0	F0	00
0F	F0	F0	F0
10	00	00	00
...	00	00	00
FF	00	00	00

	indicates unused entries
--	--------------------------

## 8 bpp color

When the SED1375 is configured for 8 bpp color mode the entire Look-Up Table is used to display images. Each of the LUT entries may be set to any of the 4096 possible colors.

Each byte in the display buffer represents one pixels. The byte value is used directly as an index into one of the 256 LUT entries. A display memory byte with a value of 00h will display the color contained in the first Look-Up Table entry while a display memory byte of FFh will display a color formed by the two hundred and fifty sixth Look-Up Table entry.

The following table depicts LUT values which approximate the VGA default 256 color palette.

*Table 4-4: Suggested LUT Values to Simulate VGA Default 256 Color Palette*

Index	R	G	B	Index	R	G	B	Index	R	G	B	Index	R	G	B
00	00	00	00	40	F0	70	70	80	30	30	70	C0	00	40	00
01	00	00	A0	41	F0	90	70	81	40	30	70	C1	00	40	10
02	00	A0	00	42	F0	B0	70	82	50	30	70	C2	00	40	20
03	00	A0	A0	43	F0	D0	70	83	60	30	70	C3	00	40	30
04	A0	00	00	44	F0	F0	70	84	70	30	70	C4	00	40	40
05	A0	00	A0	45	D0	F0	70	85	70	30	60	C5	00	30	40
06	A0	50	00	46	B0	F0	70	86	70	30	50	C6	00	20	40
07	A0	A0	A0	47	90	F0	70	87	70	30	40	C7	00	10	40
08	50	50	50	48	70	F0	70	88	70	30	30	C8	20	20	40
09	50	50	F0	49	70	F0	90	89	70	40	30	C9	20	20	40
0A	50	F0	50	4A	70	F0	B0	8A	70	50	30	CA	30	20	40
0B	50	F0	F0	4B	70	F0	D0	8B	70	60	30	CB	30	20	40
0C	F0	50	50	4C	70	F0	F0	8C	70	70	30	CC	40	20	40
0D	F0	50	F0	4D	70	D0	F0	8D	60	70	30	CD	40	20	30
0E	F0	F0	50	4E	70	B0	F0	8E	50	70	30	CE	40	20	30
0F	F0	F0	F0	4F	70	90	F0	8F	40	70	30	CF	40	20	20
10	00	00	00	50	B0	B0	F0	90	30	70	30	D0	40	20	20
11	10	10	10	51	C0	B0	F0	91	30	70	40	D1	40	20	20
12	20	20	20	52	D0	B0	F0	92	30	70	50	D2	40	30	20
13	20	20	20	53	E0	B0	F0	93	30	70	60	D3	40	30	20
14	30	30	30	54	F0	B0	F0	94	30	70	70	D4	40	40	20
15	40	40	40	55	F0	B0	E0	95	30	60	70	D5	30	40	20
16	50	50	50	56	F0	B0	D0	96	30	50	70	D6	30	40	20
17	60	60	60	57	F0	B0	C0	97	30	40	70	D7	20	40	20
18	70	70	70	58	F0	B0	B0	98	50	50	70	D8	20	40	20
19	80	80	80	59	F0	C0	B0	99	50	50	70	D9	20	40	20
1A	90	90	90	5A	F0	D0	B0	9A	60	50	70	DA	20	40	30
1B	A0	A0	A0	5B	F0	E0	B0	9B	60	50	70	DB	20	40	30

Table 4-4: Suggested LUT Values to Simulate VGA Default 256 Color Palette (Continued)

Index	R	G	B	Index	R	G	B	Index	R	G	B	Index	R	G	B
1C	B0	B0	B0	5C	F0	F0	B0	9C	70	50	70	DC	20	40	40
1D	C0	C0	C0	5D	E0	F0	B0	9D	70	50	60	DD	20	30	40
1E	E0	E0	E0	5E	D0	F0	B0	9E	70	50	60	DE	20	30	40
1F	F0	F0	F0	5F	C0	F0	B0	9F	70	50	50	DF	20	20	40
20	00	00	F0	60	B0	F0	B0	A0	70	50	50	E0	20	20	40
21	40	00	F0	61	B0	F0	C0	A1	70	50	50	E1	30	20	40
22	70	00	F0	62	B0	F0	D0	A2	70	60	50	E2	30	20	40
23	B0	00	F0	63	B0	F0	E0	A3	70	60	50	E3	30	20	40
24	F0	00	F0	64	B0	F0	F0	A4	70	70	50	E4	40	20	40
25	F0	00	B0	65	B0	E0	F0	A5	60	70	50	E5	40	20	30
26	F0	00	70	66	B0	D0	F0	A6	60	70	50	E6	40	20	30
27	F0	00	40	67	B0	C0	F0	A7	50	70	50	E7	40	20	30
28	F0	00	00	68	00	00	70	A8	50	70	50	E8	40	20	20
29	F0	40	00	69	10	00	70	A9	50	70	50	E9	40	30	20
2A	F0	70	00	6A	30	00	70	AA	50	70	60	EA	40	30	20
2B	F0	B0	00	6B	50	00	70	AB	50	70	60	EB	40	30	20
2C	F0	F0	00	6C	70	00	70	AC	50	70	70	EC	40	40	20
2D	B0	F0	00	6D	70	00	50	AD	50	60	70	ED	30	40	20
2E	70	F0	00	6E	70	00	30	AE	50	60	70	EE	30	40	20
2F	40	F0	00	6F	70	00	10	AF	50	50	70	EF	30	40	20
30	00	F0	00	70	70	00	00	B0	00	00	40	F0	20	40	20
31	00	F0	40	71	70	10	00	B1	10	00	40	F1	20	40	30
32	00	F0	70	72	70	30	00	B2	20	00	40	F2	20	40	30
33	00	F0	B0	73	70	50	00	B3	30	00	40	F3	20	40	30
34	00	F0	F0	74	70	70	00	B4	40	00	40	F4	20	40	40
35	00	B0	F0	75	50	70	00	B5	40	00	30	F5	20	30	40
36	00	70	F0	76	30	70	00	B6	40	00	20	F6	20	30	40
37	00	40	F0	77	10	70	00	B7	40	00	10	F7	20	30	40
38	70	70	F0	78	00	70	00	B8	40	00	00	F8	00	00	00
39	90	70	F0	79	00	70	10	B9	40	10	00	F9	00	00	00
3A	B0	70	F0	7A	00	70	30	BA	40	20	00	FA	00	00	00
3B	D0	70	F0	7B	00	70	50	BB	40	30	00	FB	00	00	00
3C	F0	70	F0	7C	00	70	70	BC	40	40	00	FC	00	00	00
3D	F0	70	D0	7D	00	50	70	BD	30	40	00	FD	00	00	00
3E	F0	70	B0	7E	00	30	70	BE	20	40	00	FE	00	00	00
3F	F0	70	90	7F	00	10	70	BF	10	40	00	FF	00	00	00

## 4.2.2 Gray Shade Modes

Gray shade modes are monochrome display modes. Monochrome display modes use the Look-Up Table in a very similar fashion to the color modes. This most significant difference is that the monochrome display modes use only the intensity of the green element of the Look-Up Table to form the gray level.

One side effect of using only green for intensity selection is that in gray shade modes there are only sixteen possible intensities. 8 bit-per-pixel is not supported for gray shade modes.

### 1 bpp gray shade

When the SED1375 is configured for 1 bpp gray shade mode, the LUT is limited to selecting colors from the first two green entries. The two LUT entries can be set to any of sixteen possible intensities. Typically they would be set to 0h (black) and Fh (white).

Each byte in the display buffer contains eight adjacent pixels. If a bit has a value of “0” then the color in the green LUT 0 index is displayed. A bit value of “1” results in the color in green LUT 1 index being displayed.

The following table shows the recommended values 1 bpp gray shade display mode.

*Table 4-5: Recommended LUT Values for 1 Bpp Gray Shade*

Address	Red	Green	Blue
00	00	00	00
01	00	F0	00
02	00	00	00
...	00	00	00
FF	00	00	00
	unused entries		

### 2 bpp gray shade

When the SED1375 is configured for 2 bpp gray shade, the displayed colors are selected from the first four green entries in the Look-Up Table. The remaining entries of the LUT are unused. Each of the four entries can be set to any of the sixteen possible colors.

Each byte in the display buffer contains four adjacent pixels. If a bit combination has a value of “00” then the intensity in the green LUT index 0 is displayed. A bit value of “01” results in the intensity represented by the green in LUT index 1 being displayed. Likewise the bit combination of “10” displays from the third LUT entry and “11” displays a from the fourth LUT entry.

The following table shows the example values for 2 bit-per-pixel display mode.

*Table 4-6: Suggested Values for 2 Bpp Gray Shade*

<b>Index</b>	<b>Red</b>	<b>Green</b>	<b>Blue</b>
0	00	00	00
1	00	50	00
2	00	A0	00
3	00	F0	00
4	00	00	00
...	00	00	00
FF	00	00	00

	indicates unused entries
--	--------------------------

#### 4 bpp gray shade

When the SED1375 is configured for 4 bpp gray shade mode the displayed colors are selected from the green values of the first sixteen entries of the Look-Up Table. Each of the sixteen entries can be set to any of the sixteen possible intensity levels.

Each byte in the display buffer contains two adjacent pixels. If a nibble pattern is “0000” then the green intensity of LUT index 0 is displayed. A nibble value of “0001” results in the green intensity in LUT index 1 being displayed. The pattern continues to the nibble pattern of “1111” which results in the sixteenth intensity of Look-Up Table being displayed.

The following table shows the example values for 4 bit-per-pixel display mode.

*Table 4-7: Suggested LUT Values for 4 Bpp Gray Shade*

Index	Red	Green	Blue
00	00	00	00
01	00	10	00
02	00	20	00
03	00	30	00
04	00	40	00
05	00	50	00
06	00	60	00
07	00	70	00
08	00	80	00
09	00	90	00
0A	00	A0	00
0B	00	B0	00
0C	00	C0	00
0D	00	D0	00
0E	00	E0	00
0F	00	F0	00
10	00	00	00
...	00	00	00
FF	00	00	00

	indicates unused entries
--	--------------------------

## 5 Advanced Techniques

This section contains programming suggestions for the following:

- virtual display
- panning and scrolling
- split screen display

### 5.1 Virtual Display

Virtual display refers to the situation where the image to be viewed is larger than the physical display. The difference can be in the horizontal, vertical or both dimensions. To view the image, the display is used as a window into the display buffer. At any given time only a portion of the image is visible. Panning and scrolling are used to view the full image.

The Memory Address Offset register determines the number of horizontal pixels in the virtual image. The offset register can be used to specify from 0 to 255 additional words for each scan line. At 1 bpp, 255 words span an additional 4,080 pixels. At 8 bpp, 255 words span an additional 510 pixels.

The maximum vertical size of the virtual image is the result of dividing 81920 bytes of display memory by the number of bytes on each line (i.e. at 1 bpp with a 320x240 panel set for a virtual width of 640x480 there is enough memory for 1024 lines).

Figure 5-1: “Viewport Inside a Virtual Display,” depicts a typical use of a virtual display. The display panel is 320x240 pixels, an image of 640x480 pixels can be viewed by navigating a 320x240 pixel viewport around the image using panning and scrolling.

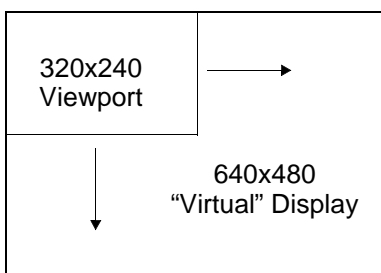

*Figure 5-1: Viewport Inside a Virtual Display*

## 5.1.1 Registers

REG[11h] Memory Address Offset Register							
Memory Address Offset Bit 7	Memory Address Offset Bit 6	Memory Address Offset Bit 5	Memory Address Offset Bit 4	Memory Address Offset Bit 3	Memory Address Offset Bit 2	Memory Address Offset Bit 1	Memory Address Offset Bit 0

### Memory Address Offset Register

REG[11h] forms an 8-bit value called the Memory Address Offset. This offset is the number of additional words on each line of the display. If the offset is set to zero there is no virtual width.

#### Note

This value does not represent the number of words to be shown on the display. The display width is set in the Horizontal Display Width register.

## 5.1.2 Examples

**Example 1: In this example we go through the calculations to display a 640x480 image on a 320x240 panel at 2 bpp.**

Step 1: Calculate the number of pixels per word for this color depth.

At 2 bpp each byte is comprised of 4 pixels, therefore each word contains 8 pixels.

$$\text{pixels\_per\_word} = 16 / \text{bpp} = 16 / 2 = 8$$

Step 2: Calculate the Memory Address Offset register value

We require a total of 640 pixels. The horizontal display register will account for 320 pixels, this leaves 320 pixels for the Memory Address Offset register to account for.

$$\text{offset} = \text{pixels} / \text{pixels\_per\_word} = 320 / 8 = 40 = 28\text{h}$$

The Memory Address Offset register, REG[11h], will have to be set to 28h to satisfy the above condition.



**Example 2: From the above, what is the maximum number of lines our image can contain?**

Step 1: Calculate the number of bytes on each line.

$$\text{bytes\_per\_line} = \text{pixels\_per\_line} / \text{pixels\_per\_byte} = 640 / 4 = 160$$

Each line of the display requires 160 bytes.

Step 2: Calculate the number of lines the SED1375 is capable of.

$$\text{total\_lines} = \text{memory} / \text{bytes\_per\_line} = 81920 / 160 = 512$$

We can display a maximum of 512 lines. Our example image requires 480 lines so this example can be done.

## 5.2 Panning and Scrolling

Panning and scrolling describe the operation of moving a physical display viewport about a virtual image in order to view the entire image a portion at time. For example, after setting up the previous example (virtual display) and drawing an image into it we would only be able to view one quarter of the image. Panning and scrolling are used to reveal the rest of the image.

Panning describes the horizontal (side to side) motion of the viewport. When panning to the right the image in the viewport appears to slide to the left. When panning to the left the image to appears to slide to the right. Scrolling describes the vertical (up and down) motion of the viewport. Scrolling down causes the image to appear to slide up and scrolling up causes the image to appear to slide down.

Both panning and scrolling are performed by modifying the start address register. The start address registers in the SED1375 are a word offset to the data to be displayed in the top left corner of a frame. Changing the start address by one means a change on the display of the number of pixels in one word. The number of pixels in word varies according to the color depth. At 1 bit-per-pixel a word contains sixteen pixels. At 2 bit-per-pixel there are eight pixels, at 4 bit-per-pixel there are four pixels and at 8 bit-per-pixel there is two pixels in each word. The number of pixels in each word represent the finest step we can pan to the left or right.

When portrait mode (see Hardware Rotation on page 37) is enabled the start address registers become offsets to bytes. In this mode the step rate for the start address registers if halved making for smoother panning.

## 5.2.1 Registers

REG[0Ch] Screen 1 Display Start Address 0 (LSB)							
Start Addr Bit 7	Start Addr Bit 6	Start Addr Bit 5	Start Addr Bit 4	Start Addr Bit 3	Start Addr Bit 2	Start Addr Bit 1	Start Addr Bit 0

REG[0Dh] Screen 1 Display Start Address 1 (MSB)							
Start Addr Bit 15	Start Addr Bit 14	Start Addr Bit 13	Start Addr Bit 12	Start Addr Bit 11	Start Addr Bit 10	Start Addr Bit 9	Start Addr Bit 8

REG[10h] Screen 1 Display Start Address 2 (MSB)							
n/a	n/a	n/a	n/a	n/a	n/a	n/a	Start Addr Bit 16

### Screen 1 Start Address Registers

These three registers form the seventeen bit screen 1 start address. Screen 1 is displayed starting at the top left corner of the display.

In landscape mode these registers form the word offset to the first byte in display memory to be displayed in the upper left corner of the screen. Changing these registers by one will shift the display image 2 to 16 pixels, depending on the current color depth.

In portrait mode these registers form the offset to the display memory byte where screen 1 will start displaying. Changing these registers in portrait mode will result in a shift of 1 to 8 pixels depending on the color depth.

Refer to Table 5-1: “Number of Pixels Panned Using Start Address” to see the minimum number of pixels affected by a change of one to these registers

Table 5-1: Number of Pixels Panned Using Start Address

Color Depth (bpp)	Pixels per Word	Landscape Mode Number of Pixels Panned	Pixels Per Byte	Portrait Mode Number of Pixels Panned
1	16	16	8	8
2	8	8	4	4
4	4	4	2	2
8	2	2	1	1

## 5.2.2 Examples

For the following examples we base our calculations on a 4 bit-per-pixel image displayed on a 256w x 64h panel. We have set up a virtual size of 320w x 240h. Width is greater than height so we are in landscape display mode. Refer to Section 2, “Initialization” on page 8 and Section 5.1, “Virtual Display” on page 25 for assistance with these settings.

These examples are shown using a C-like syntax.

### **Example 3: Panning (Right and Left)**

To pan to the right increase the start address value by one. To pan to the left decrease the start address value. Keep in mind that, with the exception of 8 bit-per-pixel portrait display mode, the display will jump by more than one pixel as a result of changing the start address registers.

Panning to the right.

```
StartWord = GetStartAddress();
StartWord ++;
SetStartAddress(StartWord);
```

Panning to the left.

```
StartWord = GetStartAddress();
StartWord --;
if (StartWord < 0)
    StartWord = 0;
SetStartAddress(StartWord);
```

The routine `GetStartAddress()` is one which will read the start address registers and return the start address as a long value. It would be written similar to:

```
long GetStartAddress()
{
    return ((REG[10] & 1) * 65536) + (REG[0D] * 256) + (REG[0C]);
}
```

The routine `SetStartAddress()` break up its long integer argument into three register values and store the values.

```
void SetStartAddress(long SA)
{
    REG[0C] = SA & 0xFF;
    REG[0D] = (SA >> 8) & 0xFF;
    REG[10] = (SA >> 16) & 0xFF;
}
```

In this example code the notation `REG[]` refers to whatever mechanism is employed to read/write the registers.

**Example 4: Scrolling (Up and Down)**

To scroll down, increase the value in the Screen 1 Display Start Address Register by the number of words in one *virtual* scan line. To scroll up, decrease the value in the Screen 1 Display Start Address Register by the number of words in one *virtual* scan line. A virtual scan line includes both the number of bytes required by the physical display and any extra bytes that may be being used for creating a virtual width on the display.

The previous dimensions are still in effect for this example (i.e. 320w x 240h virtual size, 256h x 64w physical size at 4 bpp)

Step 1: Determine the number of words in one virtual scanline.

$$\text{bytes\_per\_line} = \text{pixels\_per\_line} / \text{pixels\_per\_byte} = 320 / 2 = 160$$
$$\text{words\_per\_line} = \text{bytes\_per\_line} / 2 = 160 / 2 = 80$$

Step 2: Scroll up or down

To scroll up.

```
StartWord = GetStartAddress();
StartWord -= words_per_line;
if (StartWord < 0)
    StartWord = 0;
SetStartAddress(StartWord);
```

To scroll down.

```
StartWord = GetStartAddress();
StartWord += words_per_line;
SetStartAddress(StartWord);

}
```

## 5.3 Split Screen

Occasionally the need arises to display two different but related images. Take, for example, a game where the main play area requires rapid updates and game status, displayed at the bottom of the screen, requires infrequent updates.

The Split Screen feature of the SED1375 allows a programmer to setup a display in such a manner. When correctly configured the programmer has only to update the main area on a regular basis. Occasionally, as the need arises, the secondary area is updated.

The figure below illustrates how a 320x240 panel may be configured to have one image displaying from scan line 0 to scan line 199 and image 2 displaying from scan line 200 to scan line 239. Although this example picks specific values, the split between image 1 and image 2 may occur at any line of the display.

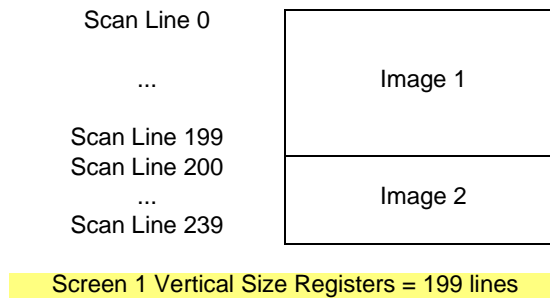

*Figure 5-2: 320x240 Single Panel For Split Screen*

In split screen operation “Image 1” is taken from the display memory location pointed to by the Screen 1 Start Address registers and is always located at the top of the screen. “Image 2” is taken from the display memory location pointed to by the Screen 2 Start Address registers. The line where “Image 1” end and “Image 2” begins is determined by the Screen 1 Vertical Size register.

### 5.3.1 Registers

Split screen operation is performed primarily by manipulating three register sets. Screen 1 Start Address and Screen 2 Start Address determine from where in display memory the first and second images will be taken from. The Vertical Size registers determine how many lines Screen 1 will use. The following is a description of the registers used to do split screen.

REG[13] Screen 1 Vertical Size (LSB)							
Bit 7	Bit 6	Bit 5	Bit 4	Bit 3	Bit 2	Bit 1	Bit 0

REG[14] Screen 1 Vertical Size (MSB)							
n/a	n/a	n/a	n/a	n/a	n/a	Bit 9	Bit 8

#### Screen 1 Vertical Size

These two registers form a ten bit value which determines the size of screen 1. When the vertical size is equal to or greater than the physical number of lines being displayed there is no visible effect on the display. When the vertical size value is less than the number of physical display lines, operation is like this:

1. From the beginning of a frame to the number of lines indicated by vertical size the display data will come from the memory area pointed to by the Screen 1 Display Start Address.
2. After *vertical size* lines have been displayed the system will begin displaying data from the memory area pointed to by Screen 2 Display Start Address.

One thing that must be pointed out here is that Screen 1 memory is **always** displayed at the top of the screen followed by screen 2 memory. This relationship holds true regardless of where in display memory Screen 1 Start Address and Screen 2 Start Address are pointing. For instance, Screen 2 Start Address may point to offset zero of display memory while Screen 1 Start Address points to a location several thousand bytes higher. Screen 1 will still be shown first on the display. While not particularly useful, it is even possible to set screen 1 and screen 2 to the same address.

REG[0Eh] Screen 2 Display Start Address 0 (LSB)							
Start Addr Bit 7	Start Addr Bit 6	Start Addr Bit 5	Start Addr Bit 4	Start Addr Bit 3	Start Addr Bit 2	Start Addr Bit 1	Start Addr Bit 0

REG[0Fh] Screen 2 Display Start Address 1 (MSB)							
Start Addr Bit 15	Start Addr Bit 14	Start Addr Bit 13	Start Addr Bit 12	Start Addr Bit 11	Start Addr Bit 10	Start Addr Bit 9	Start Addr Bit 8

### Screen 2 Start Address Registers

These three registers form the seventeen bit Screen 2 Start Address. Screen 2 is always displayed immediately following the screen 1 data and will begin at the left-most pixel on a line. Keep in mind that if the Screen 1 Vertical Size is equal to or greater than the physical display then Screen 2 will not be shown.

In landscape mode these registers form the word offset to the first byte in display memory to be displayed. Changing these registers by one will shift the display image 2 to 16 pixels, depending on the current color depth.

The SED1375 does not support split screen operation in portrait mode. Screen 2 will never be used if portrait mode is selected.

Refer to Table 5-1: “Number of Pixels Panned Using Start Address” to see the minimum number of pixels affected by a change of one to these registers

Screen 1 Start Address registers, REG[0C], REG[0D] and REG[10] are discussed in Section 5.2.1 on page 28

## 5.3.2 Examples

**Example 5: Display 200 scanlines of image 1 and 40 scanlines of image 2. Image 2 is located first (offset 0) in the display buffer followed immediately by image 1. Assume a 320x240 display and a color depth of 4 bpp.**

1. Calculate the Screen 1 Vertical Size register values.

$$\text{vertical\_size} = 200 = \text{C8h}$$

Write the Vertical Size LSB, REG[13h], with C8h and Vertical Size MSB, REG[14h], with a 00h.

2. Calculate the Screen 1 Start Word Address register values.

Screen 2 is located first in display memory, therefore we must calculate the number of bytes taken up by the screen 2 data.

$$\text{bytes\_per\_line} = \text{pixels\_per\_line} / \text{pixels\_per\_byte} = 320 / 2 = 160$$

$$\text{total bytes} = \text{bytes\_per\_line} \times \text{lines} = 160 \times 40 = 6400.$$

Screen 2 requires 6400 bytes (0 to 6399) therefore the start address offset for screen 1 must be 6400 bytes. (6400 bytes = 3200 words = C80h words)

Set the Screen 1 Start Word Address MSB, REG[0Dh], to 0Ch and the Screen 1 Start Word Address LSB, REG[0Ch], to 80h.

3. Calculate the Screen 2 Start Word Address register values.

Screen 2 display data is coming from the very beginning of the display buffer. All there is to do here is ensure that both the LSB and MSB of the Screen 2 Start Word Address registers are set to zero.



## 6 LCD Power Sequencing and Power Save Modes

### 6.1 LCD Power Sequencing

Correct power sequencing is required to prevent long term damage to LCD panels and to avoid unsightly "lines" during power-up and power-down. Power Sequencing allows the LCD power supply to discharge prior to shutting down the LCD logic signals.

Proper LCD power sequencing dictates there must be a time delay between the LCD power being disabled and the LCD signals being shut down. During power-up the LCD signals must be active prior to or when power is applied to the LCD. The time intervals vary depending on the power supply design.

The SED1375 performs automatic power sequencing in response to both software power save (REG[03h]) or in response to a hardware power save. One frame after a power save mode is set, the SED1375 disables LCD power, and the LCD logic signals continue for one hundred and twenty seven frames allowing the LCD power supply to completely discharge. For most applications the internal power sequencing is the appropriate choice.

There may be situations where the internal time delay is insufficient to discharge the LCD power supply before the LCD signals are shut down, or the delay is too long and the designer wishes to shorten it. This section details the sequences to manually power-up and power-down the LCD interface.

### 6.2 Registers

REG[03h] Mode Register 2							
				LCDPWR Override	Hardware Power Save Enable	Software Power Save bit 1	Software Power Save bit 0

The LCD Power (LCDPWR) Override bit forces LCD power inactive one frame after being toggled. As long as this bit is "1" LCD power will be disabled.

The Hardware Power Save Enable bit must be set in order to activate hardware power save through GPIO0.

The Software Power Save bits set and reset the software power save mode. These bits are set to "11" for normal operation and set to "00" for power save mode.

LCD logic signals to the display panel are active for 128 frames after setting either hardware or software power save modes. Power sequencing override is performed by setting the LCDPWR Override bit some time before setting a power save mode for power off sequences. During power on sequences the power save mode is reset some time before the LCDPWR Override is reset resulting in the LCD logic signals being active before power is applied to the panel.

## 6.3 LCD Enable/Disable

The descriptions below cover manually powering the LCD panel up and down. Use the sequences described in this section if the power supply connected to the panel requires more than 127 frames to discharge on power-down, or if the panel requires starting the LCD logic well in advance of enabling LCD power. Currently there are no known circumstances where the LCD logic must be active well in advance of LCD power.

### Note

If 127 frame period is too long, reprogram the Horizontal and Vertical sizes to produce a shorter frame period before using these methods.

### Power On/Enable Sequence

The following is a sequence for manually powering-up an LCD panel if LCD power had to be applied later than LCD logic.

1. Set REG[03h] bit 3 (LCDPWR Override) to "1". This ensures that LCD power will be held disabled.
2. Enable LCD logic. This is done by either setting the GPIO0 pin low to disable hardware power save mode and/or by setting REG[03h] bits 1-0 to "11" to disable software power save.
3. Count "x" Vertical Non-Display Periods (OPTIONAL).  
"x" corresponds to the length of time LCD logic must be enabled before LCD power-up, converted to the equivalent vertical non-display periods. For example, at 72 HZ counting 36 non-display periods results in a one half second delay.
4. Set REG[03h] bit 3 to "0" to enable LCD Power.

### Power Off/Disable Sequence

The following is a sequence for manually powering-down an LCD panel. These steps would be used if the power supply discharge requirements are larger than the default 127 frames.

1. Set REG[03h] bit 3 (LCDPWR Override) to "1" which will disable LCD Power.
2. Count "x" Vertical Non-Display Periods.  
"x" corresponds to the power supply discharge time converted to the equivalent vertical non-display periods. (see the previous example)
3. Disable the LCD logic by setting the software power save in REG[03h] or setting hardware power save via GPIO0. Keep in mind that after setting the power save mode there will be 127 frames before the LCD logic signals are disabled.

## 7 Hardware Rotation

### 7.1 Introduction To Hardware Rotation

Many of today's applications use the LCD panel in a portrait orientation (typically LCD panels are landscape oriented). In this case it becomes necessary to "rotate" the displayed image. This rotation can be done by software at the expense of performance or, as with the SED1375, it can be done by hardware with no performance penalty.

This discussion of display rotation is intended to augment the excellent description of the hardware functionality found in the Hardware Functional Specification.

The SED1375 supports two portrait modes: Default Portrait Mode and Alternate Portrait Mode.

### 7.2 Default Portrait Mode

Default portrait mode was designed to reduce power consumption for portrait mode use. The reduced power consumption comes with certain trade offs.

The most obvious difference between the two modes is that Default Portrait Mode requires the portrait width be a power of two, e.g. a 240-line panel, used in portrait mode, requires setting a virtual width of 256 pixels. Also default portrait mode is only capable of scrolling the display in two line increments.

The benefits to using default portrait mode lies in the ability to use a slower input clock and in reduced power consumption.

The following figure depicts the ways to envision memory layouts for the SED1375 in default portrait mode. This example uses a 320x240 panel.

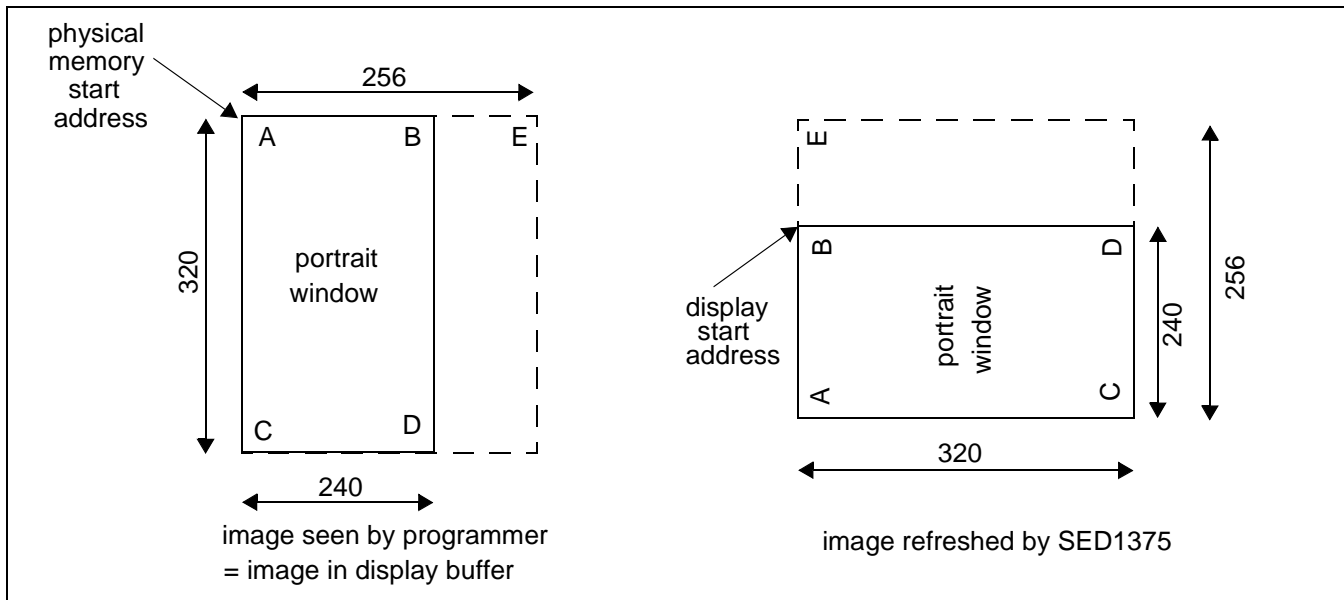

Figure 7-1: Relationship Between the Default Mode Screen Image and the Image Refreshed by SED1375

From the programmer's perspective the memory is laid out as shown on the left. The programmer accesses memory exactly as for a panel of with the dimensions of 240x320 setup to have a 256 pixel horizontal stride. The programmer sees memory addresses increasing from A->B and from B->C.

From a hardware perspective the SED1375 always refreshes the LCD panel in the order B->D and down to do A->C.

### 7.3 Alternate Portrait Mode

Alternate portrait mode does not impose the power of two line width. To rotated the image on 240 line panel requires a portrait stride of 240 pixels. Alternate portrait mode is capable of scrolling by one line at a time in response to changes to the Start Address Registers. However, to achieve the same frame rate requires a 2 x faster input clock, therefore using more power.

The following figure depicts the ways to envision memory layouts for the SED1375 in alternate portrait mode. This example also uses a 320x240 panel. Notice that in alternate portrait mode the stride may be as little as 240 pixels.

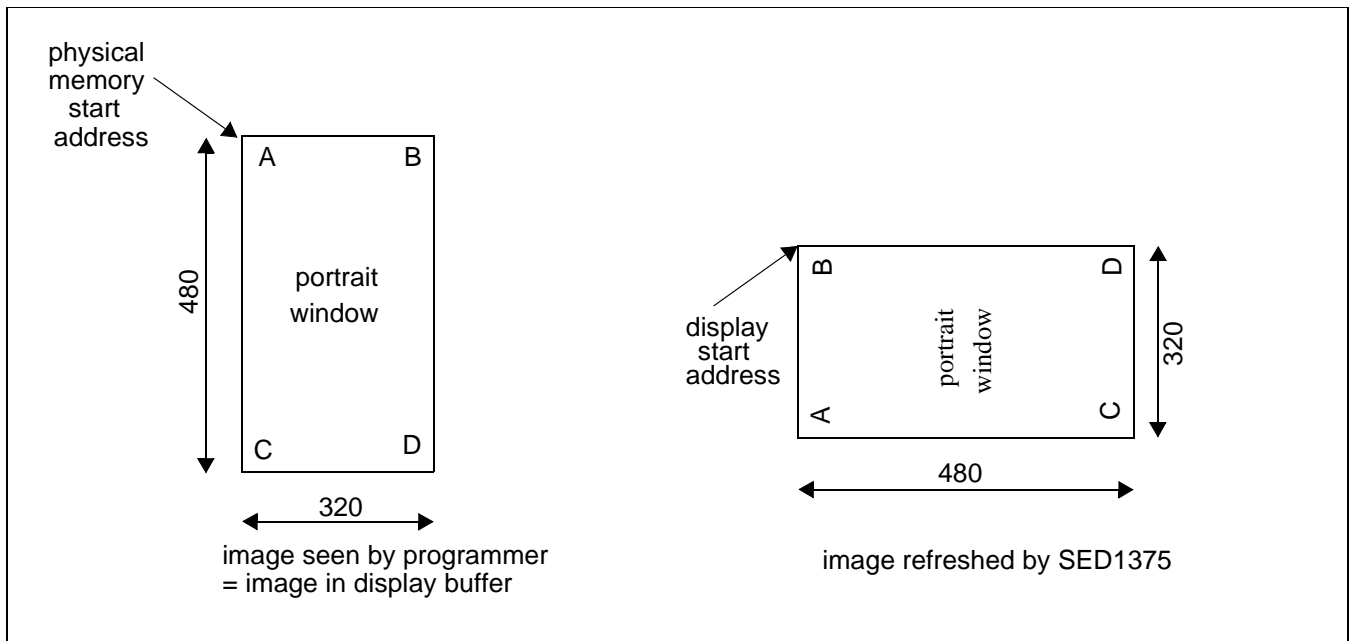

Figure 7-2: Relationship Between the Alternate Mode Screen Image and the Image Refreshed by SED1375

From the programmers perspective the memory is laid out as shown on the left. The programmer accesses memory exactly as for a panel of with the dimensions of 240x320. The programmer sees memory addresses increasing from A->B and from B->C.

From a hardware perspective the SED1375 always refreshes the LCD panel in the order B->D and down to do A->C

The greatest factor in selecting alternate portrait mode over default portrait mode would be for the ability to obtain an area of contiguous off screen memory. For example: A 640x480 panel in default portrait mode at two bit-per-pixel requires 81920 bytes (80 Kb). There is unused memory but it is not contiguous. The same situation using alternate portrait mode requires 76800 bytes leaving 5120 bytes of contiguous memory available to the application. In fact the change in memory usage may make the difference between being able to run certain panels in portrait mode or not being able to do so.

## 7.4 Registers

This section describes the registers used to set portrait mode operation.

REG[0Ch] Screen 1 Start Word Address LSB							
bit 7	bit 6	bit 5	bit 4	bit 3	bit 2	bit 1	bit 0

REG[0Dh] Screen 1 Start Word Address MSB							
bit 15	bit 14	bit 13	bit 12	bit 11	bit 10	bit 9	bit 8

REG[0Eh] Screen 1 Start Word Address MSB							
n/a	n/a	n/a	n/a	n/a	n/a	n/a	bit 16

The Screen 1 Start Address registers must be set correctly for portrait mode. In portrait mode the Start Address registers form a byte offset, as opposed to a word offset, into display memory.

The initial required offset is the portrait mode stride (in bytes) less one.

REG[1Ch] Line Byte Count Register							
bit 7	bit 6	bit 5	bit 4	bit 3	bit 2	bit 1	bit 0

The line byte count register informs the SED1375 of the stride, in bytes, between two consecutive lines of display in portrait mode. The Line Byte Count register only affects portrait mode operation and are ignored when the SED1375 is in landscape display mode.

REG[1Bh] Portrait Mode Register							
Portrait Mode Enable	Portrait Mode Select	n/a	n/a	n/a	Portrait Mode Memory Clock Select	Portrait Mode Pixel Clock Select Bit 1	Portrait Mode Pixel Clock Select Bit 0

The portrait mode register contains several items for portrait mode support.

The first is the Portrait Mode Enable bit. When this bit is “0” the SED1375 is in landscape mode and the remainder of the settings in this register as well as the Line Byte Count in REG[1Ch] are ignored. Set this bit to “1” to enable portrait mode.

The portrait mode select bit selects between the “Default Mode” and the “Alternate Mode”. Setting this bit to “0” selects the default portrait mode while setting this bit to “1” enables the alternate portrait mode.

Portrait Mode Memory Clock Select is another power saving measure which can be enabled if the final MCLK value is less than or equal to 25 MHz. Memory Clock Select results in the SED1375 temporarily increasing the memory clock circuitry on CPU access and resuming the slower speed when the access is complete. This results in better performance while using the least power.

In portrait display mode the CLKI (input clock) is routed to the portrait section of the SED1375 as CLK. From the CLK signal the MCLK value can be determined from table 8-8 of the Hardware Functional Specification, document number X27A-A-001-xx. If MCLK is determined to be less than or equal to 25 MHz then Portrait Mode Memory Clock Select may be enabled.

## 7.5 Limitations

The only limitation to using portrait mode on the SED1375 is that split screen operation is not supported.

A comparison of the two portrait modes is as follows:

*Table 7-1: Default and Alternate Portrait Mode Comparison*

Item	Default Portrait Mode	Alternate Portrait Mode
Memory Requirements	The width of the rotated image must be a power of 2. In most cases, a virtual image is required where the right-hand side of the virtual image is unused and memory is wasted. For example, a 320x480x4bpp image would normally require only 76,800 bytes - possible within the 80K byte address space, but the virtual image is 512x480x4bpp which needs 122,880 bytes - not possible.	Does not require a virtual image.
Clock Requirements	CLK need only be as fast as the required PCLK.	MCLK, and hence CLK, need to be 2x PCLK. For example, if the panel requires a 3MHz PCLK, then CLK must be 6MHz. Note that 25MHz is the maximum CLK, so PCLK cannot be higher than 12.5MHz in this mode.
Power Consumption	Lowest power consumption.	Higher than Default Mode.
Panning	Vertical panning in 2 line increments.	Vertical panning in 1 line increments.
Performance	Nominal performance. Note that performance can be increased by increasing CLK and setting MCLK = CLK (REG[1Bh] bit 2 = 1).	Higher performance than Default Mode. Note that performance can be increased by increasing CLK and setting MCLK = CLK (REG[1Bh] bit 2 = 1).



## 7.6 Examples

### **Example 6: Enable default portrait mode for a 320x240 panel at 4 bpp.**

Before switching to portrait mode from landscape mode, display memory should be cleared to make the user perceived transition smoother. Images in display memory are not rotated automatically by hardware and a garbled image would be visible for a short period of time if video memory is not cleared.

If alternate portrait is used then the CLK signal is divided in half to get the PCLK signal. If the Input Clock Divide bit, in register[02] is set we can simply reset the divider. The result of this is a PCLK of exactly the same frequency as we used for landscape mode and we can use the current horizontal and vertical non-display periods. If the Input Clock Divide bit is not set then we must recalculate the frame rate based on the a PCLK value. In this example we will bypass recalculation of the horizontal and vertical non-display times (frame rate) by selecting the default portrait mode scheme.

1. Calculate and set the Screen 1 Start Word Address register.

$$\text{OffsetBytes} = (\text{Width} \times \text{BitsPerPixel} / 8) - 1 = (256 \times 4 / 8) - 1 = 127 = 007\text{Fh}$$

(“Width” is the width of the portrait mode display - in this case the next power of two greater than 240 pixels or 256.)

Set Screen1 Display Start Word Address LSB (REG [0Ch]) to 7Fh and Screen1 Display Start Word Address MSB (REG[0Dh]) to 00h.

2. Calculate the Line Byte Count

The Line Byte Count also must be based on the power of two width.

$$\text{LineByteCount} = \text{Width} \times \text{BitsPerPixel} / 8 = 256 \times 4 / 8 = 128 = 80\text{h.}$$

Set the Line Byte Count (REG[1C]) to 80h.

3. Enable portrait mode.

This example uses the default portrait mode scheme. If we do not change the Portrait Mode Pixel Clock Select bits then we will not have to recalculate the non-display timings to correct the frame rate.

Write 80h to the Portrait Mode Register (REG[1Bh]).

The display is now configured for portrait mode use. Offset zero into display memory will correspond to the upper left corner of the display. The only item to keep in mind is that the count from the first pixel of one line to the first pixel of the next line (referred to as the “stride”) is 128 bytes.

**Example 7: Enable alternate portrait mode for a 320x240 panel at 4 bpp.****Note**

As we have to perform a frame rate calculation for this mode we need to know the following panel characteristics: 320x240 8-bit color to be run at 80 Hz with a 16 MHz input clock.

As in the previous example, before switching to portrait mode, display memory should be cleared. Images in display memory are not rotated automatically by hardware and the garbled image would be visible for a short period of time if video memory is not cleared.

1. Calculate and set the Screen 1 Start Word Address register.

$$\text{OffsetBytes} = (\text{Width} \times \text{BitsPerPixel} / 8) - 1 = (240 \times 4 / 8) - 1 = 119 = 0077\text{h}$$

Set Screen1 Display Start Word Address LSB (REG [0Ch]) to 77h and Screen1 Display Start Word Address MSB (REG[0Dh]) to 00h.

2. Calculate the Line Byte Count.

$$\text{LineByteCount} = \text{Width} \times \text{BitsPerPixel} / 8 = 240 \times 4 / 8 = 120 = 78\text{h.}$$

Set the Line Byte Count (REG[1C]) to 78h.

3. Enable portrait mode.

This example uses the alternate portrait mode scheme. We will not change the MCLK Autoswitch or Pixel Clock Select settings.

Write C0h to the Portrait Mode register (REG[1Bh])

4. Recalculate the frame rate dependents.

This example assumes the alternate portrait mode scheme. In this scheme, without touching the Pixel Clock Select bits the PCLK value will be equal to CLK/2.

These examples don't use the Pixel Clock Select bits. The ability to divide the PCLK value down further than the default values was added to the SED1375 to support hardware portrait mode on very small panels.

The Pixel Clock value has changed so we must calculate horizontal and vertical non-display times to reach the desired frame rate. Rather than perform the frame rate calculations here I will refer the reader to the frame rate calculations in Frame Rate Calculation on page 9 and simply "arrive" at the following:

$$\text{Horizontal Non-Display Period} = 88\text{h}$$

$$\text{Vertical Non-Display Period} = 03\text{h}$$

Plugging the values into the frame rate calculations yields:

$$\text{FrameRate} = \frac{\text{PCLK}}{(\text{HDP} + \text{HNDP}) \times (\text{VDP} + \text{VNDP})}$$

$$\text{FrameRate} = \frac{\frac{16,000,000}{2}}{(320 + 88) \times (240 + 3)} = 80.69$$

For this example the Horizontal Non-Display register [REG[08h]] needs to be set to 07h and the Vertical Non-Display register (REG[0Ah]) needs to be set to 03h.

The 16,000,000/2 in the formula above represents the input clock being divided by two when this alternate portrait mode is selected. With the values given for this example we must ensure the Input Clock Divide bit (REG[02h] b4) is reset (with the given values it was likely set as a result of the frame rate calculations for landscape display mode).

No other registers need to be altered.

The display is now configured for portrait mode use. Offset zero of display memory corresponds to the upper left corner of the display. Display memory is accessed exactly as it was for landscape mode.

As this is the alternate portrait mode the power of two stride issue encountered with the default portrait mode is no longer an issue. The stride is the same as the portrait mode width. In this case 120 bytes.

**Example 8: Pan the above portrait mode image to the right by 4 pixels then scroll it up by 6 pixels.**

To pan by four pixels the start address needs to be advanced.

1. Calculate the number of bytes to change start address by.

$$\text{Bytes} = \text{Pixels} \times \text{BitsPerPixel} / 8 = 4 \times 4 / 8 = 2 \text{ bytes}$$

2. Increment the start address registers by the just calculated value.

In this case the value write to the start address register will be 81h ( $7Fh + 2 = 81h$ )

To scroll by 4 lines we have to change the start address by the offset of four lines of display.

1. Calculate the number of bytes to change start address by.

$$\text{BytesPerLine} = \text{LineByteCount} = 128$$

$$\text{Bytes} = \text{Lines} \times \text{BytesPerLine} = 4 \times 128 = 512 = 200h$$

2. Increment the start address registers by the just calculated value

In this case 281h ( $81h + 200h$ ) will be written to the Screen 1 Start Address register set.

Set Screen1 Display Start Word Address LSB (REG[0Ch]) to 81h and Screen1 Display Start Word Address MSB (REG[0Dh]) to 02h.

## 8 Identifying the SED1375

There are several similar products in the 135X and 137X LCD controller families. Products which can share significant portions of a generic code base. It may be important for a program to identify between products at run time.

Identification of the SED1375 can be performed any time after the system has been powered up by reading REG[00h], the Revision Code register. The six most significant bits form the product identification code and the two least significant bits form the product revision.

From reset (power on) the steps to identifying the SED1375 are as follows:

1. Read REG[00h]. Mask off the lower two bits, the revision code, to obtain the product code.
2. The product code for the SED1375 is 024h.

## 9 Hardware Abstraction Layer (HAL)

### 9.1 Introduction

The HAL is a processor independent programming library provided by Epson. The HAL was developed to aid the implementation of internal test programs, and provides an easy, consistent method of programming the SED1375 on different processor platforms. The HAL also allows for easier porting of programs between SED137X products. Integral to the HAL is an information structure (HAL\_STRUCT) that contains configuration data on clocks, display modes, and default register values. This structure combined with the utility 1375CFG.EXE allows quick customization of a program for a new target display or environment.

Using the HAL keeps sample code simpler, although some programmers may find the HAL functions to be limited in their scope, and may wish to program the SED1375 without using the HAL.

### 9.2 Contents of the HAL\_STRUCT

The HAL\_STRUCT below is contained in the file “hal.h” and is required to use the HAL library.

```
typedef struct tagHalStruct
{
    char    szIdString[16];
    WORD    wDetectEndian;
    WORD    wSize;
    BYTE    Regs [MAX_REG + 1];
    DWORD   dwClkI;           /* Input Clock Frequency (in kHz) */
    DWORD   dwDispMem;       /* Starting address of display buffer memory */
    WORD    wFrameRate;      /* Desired panel frame rate */
} HAL_STRUCT;
```

Within the Regs array is a structure which defines all the registers described in the *SED1375 Hardware Functional Specification*, document number X27A-A-001-xx. Using the 1375CFG.EXE utility you can adjust the content of the registers contained in HAL\_STRUCT to allow for different LCD panel timing values and other default settings used by the HAL. In the simplest case, the program only calls a few basic HAL functions and the contents of the HAL\_STRUCT are used to setup the SED1375 for operation.

## 9.3 Using the HAL library

To utilize the HAL library, the programmer must include two “.h” files in their code. “Hal.h” contains the HAL library function prototypes and structure definitions, and “appcfg.h” contains the instance of the HAL\_STRUCT that is defined in “Hal.h” and configured by 1375CFG.EXE. For a more thorough example of using the HAL see Section 10.1, “Sample code using the SED1375 HAL API” on page 66.

### Note

Many of the HAL library functions have pointers as parameters. The programmer should be aware that little validation of these pointers is performed, so it is up to the programmer to ensure that they adhere to the interface and use valid pointers. Programmers are recommended to use the highest warning levels of their compiler in order to verify the parameter types.

## 9.4 API for 1375HAL

This section is a description of the HAL library Application Programmers Interface (API). Updates and revisions to the HAL may include new functions not included in this documentation.

Table 9-1: HAL Functions

Function	Description
Initialization:	
seRegisterDevice	Registers the SED1375 parameters with the HAL, calls seInitHal if necessary. seRegisterDevice MUST be the first HAL function called by an application.
seSetInit	Programs the SED1375 for use with the default settings, calls seSetDisplayMode to do the work, clears display memory. Note: either seSetInit or seSetDisplayMode must be called AFTER calling seRegisterDevice
General HAL Support:	
seGetId	Interpret the revision code register to determine chip id
seGetHalVersion	Return version information on the HAL library
seGetLastUsableByte	Determine the offset of the last unreserved usable byte in the display buffer
seGetBytesPerScanline	Determine the number of bytes or memory consumed per scan line in current mode
seGetScreenSize	Determine the height and width of the display surface in pixels
seDelay	Use the frame rate timing to delay for required seconds (requires registers to be initialized)
seSetHighPerformance	Used in color modes less than 8-bpp to toggle the high performance bit on or off
Advanced HAL Functions:	
seSplitInit	Initialize split screen variables and setup start addresses
seSplitScreen	Set the size of either the top or bottom screen
seVirtInit	Initialize virtual screen mode setting x and y sizes
seVirtMove	pan/scroll the virtual screen surface(s)
Hardware Rotate:	
seSetHWRotate	Set the hardware rotation to either Portrait or Landscape
seSetPortraitMethod	Call before setting hardware portrait mode to set either Default or Alternate Portrait Mode

Table 9-1: HAL Functions (Continued)

Function	Description
<b>Register / Memory Access:</b>	
seSetReg	Write a Byte value to the specified SED1375 register
seGetReg	Read a Byte value from the specified SED1375 register
seWriteDisplayBytes	Write one or more bytes to the display buffer at the specified offset
seWriteDisplayWords	Write one or more words to the display buffer at the specified offset
seWriteDisplayDwords	Write one or more dwords to the display buffer at the specified offset
seReadDisplayByte	Read a byte from the display buffer from the specified offset
seReadDisplayWord	Read a word from the display buffer from the specified offset
seReadDisplayDword	Read a dword from the display buffer from the specified offset
<b>Color Manipulation:</b>	
seSetLut	Write to the Look-Up Table (LUT) entries starting at index 0
seGetLut	Read from the LUT starting at index 0
seSetLutEntry	Write one LUT entry (red, green, blue) at the specified index
seGetLutEntry	Read one LUT entry (red, green, blue) from the specified index
seSetBitsPerPixel	Set the color depth
seGetBitsPerPixel	Determine the current color depth
<b>Drawing:</b>	
seSetPixel	Draw a pixel at (x,y) in the specified color
seGetPixel	Read pixel's color at (x,y)
seDrawLine	Draw a line from (x1,y1) to (x2,y2) in specified color
seDrawRect	Draw a rectangle from (x1,y1) to (x2,y2) in specified color
<b>Power Save:</b>	
seSetPowerSaveMode	Control SED1375 SW power save mode (enable/disable)



## 9.4.1 Initialization

The following section describes the HAL functions dealing with SED1375 initialization. Typically a programmer has only to concern themselves with calls to `seRegisterDevice()` and `seSetInit()`.

### **int seRegisterDevice(const LPHAL\_STRUC lpHalInfo)**

**Description:** This function registers the SED1375 device parameters with the HAL library. The device parameters include address range, register values, desired frame rate, etc., and are stored in the HAL\_STRUCT structure pointed to by lpHalInfo. Additionally this routine allocates system memory as address space for accessing registers and the display buffer.

**Parameters:** lpHalInfo - pointer to HAL\_STRUCT information structure

**Return Value:** ERR\_OK - operation completed with no problems  
ERR\_UNKNOWN\_DEVICE - the HAL was unable to find an SED1375.

#### **Note**

`seRegisterDevice()` MUST be called before any other HAL functions.  
No SED1375 registers are changed by calling `seRegisterDevice()`.

### **seSetInit()**

**Description:** Configures the SED1375 for operation. This function sets all the SED1375 control registers to their default values.

Initialization of the SED1375 is a two step process to accommodate those programs (e.g. 1375PLAY.EXE) which do not initialize the SED1375 on start-up.

**Parameters:** None

**Return Value:** ERR\_OK - operation completed with no problems

#### **Note**

After this call the Look-Up Table will be set to a default state appropriate to the display type.

Unlike SED135x HAL versions, this function does not call `seSetDisplayMode` as this function does not exist in the 1375 HAL.

## 9.4.2 General HAL Support

Functions in this group do not fit into any specific category of support. They provide a miscellaneous range of support for working with the SED1375

### **int seGetId(int \* pId)**

**Description:** Reads the SED1375 revision code register to determine the chip product and revisions. The interpreted value is returned in pID.

**Parameters:** pId - pointer to an integer which will receive the controller ID.

SED1375 values returned in pID are:

- ID\_SED1375\_REV0

- ID\_UNKNOWN

Other HAL libraries will return their respective controller IDs upon detection of their controller.

**Return Value:** ERR\_OK - operation completed with no problems  
ERR\_UNKNOWN\_DEVICE - the HAL was unable to identify the display controller. Returned when pID returns ID\_UNKNOWN.

### **void seGetHalVersion(const char \*\* pVersion, const char \*\* pStatus, const char \*\*pStatusRevision)**

**Description:** Retrieves the HAL library version. The return pointers are all to ASCII strings. A typical return would be: \*pVersion == "1.01" (HAL version 1.01), \*pStatus == "B" (The 'B' is the beta designator), \*pStatusRevision == "5". The programmer need only create pointers of const char type to pass as parameters (see Example below).

**Parameters:** pVersion - Pointer to string to return the version in.  
- must point to an allocated string of size VER\_SIZE  
pStatus - Pointer to a string to return the release status in.  
- must point to an allocated string of size STATUS\_SIZE  
pStatusRevision - Pointer to return the current revision of status.  
- must point to an allocated string of size STAT\_REV\_SIZE

**Return Value:** None

**Example:** const char \*pVersion, \*pStatus, \*pStatusRevision;  
seGetHalVersion( &pVersion, &pStatus, &pStatusRevision);

### **int seSetBitsPerPixel(int BitsPerPixel)**

**Description:** This routine sets the display color depth.

After performing validity checks to ensure the requested video mode can be set the appropriate registers are changed and the Look-Up Table is set its default values appropriate to the color depth.

This call is similar to a mode set call on a standard VGA.

**Parameter:** BitsPerPixel - desired color depth in bits per pixel.  
- Valid arguments are: 1, 2, 4, and 8.

**Return Value:** ERR\_OK - operation completed with no problems  
ERR\_FAILED- possible causes for this error include:

- 1) the desired frame rate may not be attainable with the specified input clock
- 2) the combination of width, height and color depth may require more memory than is available on the SED1375.

### **int seGetBitsPerPixel(int \* pBitsPerPixel)**

**Description:** This function reads the SED1375 registers to determine the current color depth and returns the result in *pBitsPerPixel*.

**Parameters:** pBitsPerPixel - pointer to an integer to receive current color depth.  
- return values will be: 1, 2, 4, or 8.

**Return Value:** ERR\_OK - operation completed with no problems

### **int seGetBytesPerScanline(int \* pBytes)**

**Description:** Determines the number of bytes per scan line of current display mode. It is assumed that the registers have already been correctly initialized before *seGetBytesPerScanline()* is called (i.e. after initializing the HAL, setting the Display mode and adjusting the bits per pixel or other values).

The number of bytes per scanline will include non-displayed bytes if the screen width is greater the display width, or in Default Portrait Mode.

**Parameters:** pBytes - pointer to an integer to receive the number of bytes per scan line

**Return Value:** ERR\_OK - operation completed with no problems

### **int seGetScreenSize(int \* Width, int \* Height)**

**Description:** Retrieves the width and height in pixels of the display surface. The width and height are derived by reading the horizontal and vertical size registers and calculating the dimensions. Virtual dimensions are not taken into account for this calculation.

When the display is in portrait mode the dimensions will be swapped. (i.e. a 640x480 display in portrait mode will return a width of 480 and height of 640).

**Parameters:** Width - pointer to an integer to receive the display width  
Height - pointer to an integer to receive the display height

**Return value:** ERR\_OK - the operation completed successfully

### **int seDelay(int MilliSeconds)**

**Description:** This function will delay for the length of time specified in “MilliSeconds” before returning to the caller.

This function was originally intended for non-PC platforms. Information about how to access the timers was not always available however we do know frame rate and can use that for timing calculations.

The SED1375 registers must be initialized for this function to work correctly. On the PC platform this is simply a call to the C timing functions and is therefore independent of the register settings.

**Parameters:** MilliSeconds- time to delay in seconds

**Return Value:** ERR\_OK - operation completed with no problems  
ERR\_FAILED- returned on non-PC platforms when the SED1375 registers have not been initialized

### **int seGetLastUsableByte(long \* pLastByte)**

**Description:** This function returns a pointer, as a long integer, to the last byte of usable display memory.

The returned value never changes for the SED1375.

**Parameters:** pLastByte - pointer to a long integer to receive the offset to the last byte of display memory

**Return Value:** ERR\_OK - operation completed with no problems

### **int seSetHighPerformance(BOOL OnOff)**

**Description:** This function call enables or disable the high performance bit of the SED1375.

When high performance is enabled then MClk equals PClk for all video display resolutions. In the high performance state CPU to video memory performance is improved at the cost of higher power consumption.

When high performance is disabled then MClk ranges from PClk/1 at 8 bit-per-pixel to PClk/8 at 1 bit-per-pixel. Without high performance CPU to video memory speeds are slower and the SED1375 uses less power.

**Parameters:** OnOff - a boolean value (defined in HAL.H) to indicate whether to enable or disable high performance.

**Return Value:** ERR\_OK - operation completed with no problems

## **9.4.3 Advanced HAL Functions**

Advanced HAL functions include the functions to support split, virtual and rotated displays. While the concept for using these features is advanced the HAL makes actually using them easy.

### **int seSetPortraitMethod( int Style )**

**Description:** This selects the portrait mode method to be used when seSetHWRotate() is called to put the SED1375 into portrait mode.

**Parameters:** Style - call with style set to DEFAULT (-1) to select Default Portrait Mode  
- call with style set to any other value to select Alternate Portrait Mode.

**Return Value:** ERR\_OK - operation completed with no problems  
ERR\_FAILED - the operation failed.

### **int seSetHWRotate(int Rotate)**

**Description:** This function sets the rotation scheme according to the value of 'Rotate'. When portrait mode is selected as the display rotation the scheme selected is the 'non-X2' scheme.

**Parameters:** Rotate - the direction to rotate the display  
- Valid arguments for Rotate are: LANDSCAPE and PORTRAIT.

**Return Value:** ERR\_OK - operation completed with no problems  
ERR\_FAILED - the operation failed to complete.  
The most likely reason for failing to set a rotate mode is an inability to set the desired frame rate when setting portrait mode. Other factors which can cause a failure include having a 0 Hz frame rate or specifying a value other than LANDSCAPE or PORTRAIT for the rotation scheme.

**int seSplitInit(WORD Scrn1Addr, WORD Scrn2Addr)**

**Description:** This function prepares the system for split screen operation. In order for split screen to function the starting address in the display buffer for the upper portion(screen 1) and the lower portion (screen 2) must be specified. Screen 1 is always displayed above screen 2 on the display regardless of the location of their start addresses.

**Parameters:** Scrn1Addr - offset, in bytes, to the start of screen 1  
Scrn2Addr - offset, in bytes, to the start of screen 2

**Return Value:** ERR\_OK - operation completed with no problems

**Note**

It is assumed that the system has been initialized prior to calling seSplitInit().

**int seSplitScreen(int Screen, int VisibleScanlines)**

**Description:** Changes the relevant registers to adjust the split screen according to the number of visible lines requested. 'WhichScreen' determines which screen, 1 or 2, to base the changes on.

The smallest surface screen 1 can display is one line. This is due to the way the SED1375 operates. Setting Screen 1 Vertical Size to zero results in one line of screen 1 being displayed. The remainder of the display will be screen 2 image.

**Parameters:** Screen - must be set to 1 or 2 (or use the constants SCREEN1 or SCREEN2)  
VisibleScanlines- number of lines to display for the selected screen

**Return Value:** ERR\_OK - operation completed with no problems  
ERR\_HAL\_BAD\_ARG- argument VisibleScanlines is negative or is greater than vertical panel size or WhichScreen is not SCREEN1 or SCREEN 2.

**Note**

Changing the number of lines for one screen will also change the number of lines for the other screen.

seSplitInit() must be called before calling seSplitScreen().

## **int seVirtInit(DWORD VirtX, DWORD \* VirtY)**

**Description:** This function prepares the system for virtual screen operation. The programmer passes the desired virtual width in pixels. When the routine returns *VirtY* will contain the maximum number of line that can be displayed at the requested virtual width.

**Parameter:** VirtX - horizontal size of virtual display in pixels.  
(Must be greater or equal to physical size of display)  
VirtY - pointer to an integer to receive the maximum number of displayable lines of 'VirtX' width.

**Return Value:** ERR\_OK - operation completed with no problems  
ERR\_HAL\_BAD\_ARG - returned in three situations:  
1) the virtual width (VirtX) is greater than the largest possible width (VirtX varies with color depth and ranges from 4096 pixels wider than the panel at 1 bit-per-pixel down to 512 pixels wider than the panel at 8 bit-per-pixel)  
2) the virtual width is less than the physical width or  
3) the maximum number of lines becomes less than the physical number of lines

### **Note**

The system must have been initialized prior to calling seVirtInit()

## **int seVirtMove(int Screen, int x, int y)**

**Description:** This routine pans and scrolls the display. In the case where split screen operation is being used, the Screen argument specifies which screen to move. The x and y parameters specify, in pixels, the starting location in the virtual image for the top left corner of the applicable display.

**Parameter:** Screen - must be set to 1 or 2, or use the constants SCREEN1 or SCREEN2, to identify which screen to base calculations on  
x - new starting X position in pixels  
y - new starting Y position in pixels

**Return Value:** ERR\_OK - operation completed with no problems  
ERR\_HAL\_BAD\_ARG- there are several reasons for this return value:  
1) WhichScreen is not SCREEN1 or SCREEN2.  
2) the y argument is greater than the last available line less the screen height.

### **Note**

seVirtInit() must be called before calling seVirtMove().

## 9.4.4 Register / Memory Access

The Register/Memory Access functions provide access to the SED1375 registers and display buffer through the HAL.

### **int seGetReg(int Index, BYTE \* pValue)**

**Description:** Reads the value in the register specified by index.

**Parameters:** Index - register index to read  
pValue - pointer to a BYTE to receive the register value.

**Return Value:** ERR\_OK - operation completed with no problems

### **int seSetReg(int Index, BYTE Value)**

**Description:** Writes value specified in Value to the register specified by Index.

**Parameters:** Index - register index to set  
Value - value to write to the register

**Return Value:** ERR\_OK - operation completed with no problems

### **int seReadDisplayByte(DWORD Offset, BYTE \*pByte)**

**Description:** Reads a byte from the display buffer at the specified offset and returns the value in pByte.

**Parameters:** Offset - offset, in bytes from start of the display buffer, to read from  
pByte - pointer to a BYTE to return the value in

**Return Value:** ERR\_OK - operation completed with no problems  
ERR\_HAL\_BAD\_ARG - if the value for Addr is greater 80 kb

### **int seReadDisplayWord(DWORD Offset, WORD \*pWord)**

**Description:** Reads a word from the display buffer at the specified offset and returns the value in pWord.

**Parameters:** Offset - offset, in bytes from start of the display buffer, to read from  
pWord - pointer to a WORD to return the value in

**Return Value:** ERR\_OK - operation completed with no problems.  
ERR\_HAL\_BAD\_ARG - if the value for Addr is greater than 80 kb.



### **int seReadDisplayDword(DWORD Offset, DWORD \*pDword)**

**Description:** Reads a dword from the display buffer at the specified offset and returns the value in pDword.

**Parameters:** Offset - offset from start of the display buffer to read from  
pDword - pointer to a DWORD to return the value in

**Return Value:** ERR\_OK - operation completed with no problems.  
ERR\_HAL\_BAD\_ARG - if the value for Addr is greater than 80 kb.

### **int seWriteDisplayBytes(DWORD Offset, BYTE Value, DWORD Count)**

**Description:** This routine writes one or more bytes to the display buffer at the offset specified by Offset. If a count greater than one is specified all bytes will have the same value.

**Parameters:** Offset - offset from start of the display buffer to start writing at  
Value - BYTE value to write  
Count - number of bytes to write

**Return Value:** ERR\_OK - operation completed with no problems  
ERR\_HAL\_BAD\_ARG - if the value for Addr or the value of Addr plus Count is greater than 80 kb.

#### **Note**

There are slight functionality differences between the SED137x and the SED135x HAL.

### **int seWriteDisplayWords(DWORD Offset, WORD Value, DWORD Count)**

**Description:** Writes one or more WORDS to the display buffer at the offset specified by Addr. If a count greater than one is specified all WORDS will have the same value.

**Parameters:** Offset - offset from start of the display buffer  
Value - WORD value to write  
Count - number of words to write

**Return Value:** ERR\_OK - operation completed with no problems  
ERR\_HAL\_BAD\_ARG - if the value for Addr or if Addr plus Count is greater than 80 kb.

#### **Note**

There are slight functionality differences between the SED137x and the SED135x HAL.

**int seWriteDisplayDwords(DWORD Offset, DWORD Value, DWORD Count)**

**Description:** Writes one or more DWORDS to the display buffer at the offset specified by Addr. If a count greater than one is specified all DWORDSs will have the same value.

**Parameters:** Offset - offset from start of the display buffer  
Value - DWORD value to write  
Count - number of dwords to write

**Return Value:** ERR\_OK - operation completed with no problems  
ERR\_HAL\_BAD\_ARG - if the value for Addr or if Addr plus Count is greater than 80 kb.

**Note**

There are slight functionality differences between the SED137x and the SED135x HAL.

**9.4.5 Power Save**

This section covers the HAL functions dealing with the Power Save features of the SED1375.

**int seSetPowerSaveMode(int PwrSaveMode)**

**Description:** This function sets on the SED1375's software selectable power save modes.

**Parameters:** PwrSaveMode - integer value specifying the desired power save mode.

Acceptable values for PwrSaveMode are:

0 - (software power save mode) in this mode registers and memory are read/writable. LCD output is forced low.

3 - (normal operation) all outputs function normally.

**Return Value:** ERR\_OK - operation completed with no problems

## 9.4.6 Drawing

The Drawing routines cover HAL functions that deal with displaying pixels, lines and shapes.

### **int seSetPixel(long x, long y, DWORD Color)**

**Description:** Draws a pixel at coordinates (x,y) in the requested color. This routine can be used for any color depth.

**Parameters:** x - horizontal coordinate of the pixel (starting from 0)  
y - vertical coordinate of the pixel (starting from 0)  
Color - at 1, 2, 4, and 8 bpp Color is an index into the LUT.  
At 15 and 16 bpp Color defines the color directly  
(i.e. rrrrrgggggbbbb for 16 bpp)

**Return Value:** ERR\_OK - operation completed with no problems.

### **int seGetPixel(long x, long y, DWORD \*pColor)**

**Description:** Reads the pixel color at coordinates (x,y). This routine can be used for any color depth.

**Parameters:** x - horizontal coordinate of the pixel (starting from 0)  
y - vertical coordinate of the pixel (starting from 0)  
pColor - at 1, 2, 4, and 8 bpp pColor points to an index into the LUT.  
At 15 and 16 bpp pColor points to the color directly  
(i.e. rrrrrgggggbbbb for 16 bpp)

**Return Value:** ERR\_OK - operation completed with no problems.

### **int seDrawLine(int x1, int y1, int x2, int y2, DWORD Color)**

**Description:** This routine draws a line on the display from the endpoints defined by x1,y1 to the endpoint x2,y2 in the requested 'Color'.

Currently seDrawLine() only draws horizontal and vertical lines.

**Parameters:** (x1, y1) - first endpoint of the line in pixels  
(x2, y2) - second endpoint of the line in pixels (see note below)  
Color - color to draw with. 'Color' is an index into the LUT.

**Return Value:** ERR\_OK - operation completed with no problems

#### **Note**

Functionality differs from the 135x HAL.

**int seDrawRect(long x1, long y1, long x2, long y2, DWORD Color, BOOL SolidFill)**

**Description:** This routine draws and optionally fills a rectangular area of display buffer. The upper right corner is defined by x1,y1 and the lower right corner is defined by x2,y2. The color, defined by *Color*, applies both to the border and to the optional fill.

**Parameters:**

x1, y1	- top left corner of the rectangle (in pixels)
x2, y2	- bottom right corner of the rectangle (in pixels)
Color	- The color to draw the rectangle outline and fill with - Color is an index into the Look-Up Table.
SolidFill	- Flag whether to fill the rectangle or simply draw the border. - Set to 0 for no fill, set to non-0 to fill the inside of the rectangle

**Return Value:** ERR\_OK - operation completed with no problems.

**9.4.7 LUT Manipulation**

These functions deal with altering the color values in the Look-Up Table.

**int seSetLut(BYTE \*pLut, int Count)**

**Description:** This routine writes one or more LUT entries. The writes always start with Look-Up Table index 0 and continue for 'Count' entries.

A Look-Up Table entry consists of three bytes, one each for Red, Green, and Blue. The color information is stored in the four most significant bits of each byte.

**Parameters:**

pLut	- pointer to an array of BYTE lut[16][3] lut[x][0] == RED component lut[x][1] == GREEN component lut[x][2] == BLUE component
Count	- the number of LUT entries to write.

**Return Value:** ERR\_OK - operation completed with no problems

**int seGetLut(BYTE \*pLUT, int Count)**

**Description:** This routine reads one or more LUT entries and puts the result in the byte array pointed to by pLUT.

A Look-Up Table entry consists of three bytes, one each for Red, Green, and Blue. The color information is stored in the four most significant bits of each byte.

**Parameters:**

pLUT	- pointer to an array of BYTE lut[16][3] - pLUT must point to enough memory to hold 'Count' x 3 bytes of data.
Count	- the number of LUT elements to read.

**Return Value:** ERR\_OK - operation completed with no problems

### **int seSetLutEntry(int Index, BYTE \*pEntry)**

**Description:** This routine writes one LUT entry. Unlike seSetLut, the LUT entry indicated by 'Index' can be any value from 0 to 255.

A Look-Up Table entry consists of three bytes, one each for Red, Green, and Blue. The color information is stored in the four most significant bits of each byte.

**Parameters:** Index - index to LUT entry (0 to 255)  
pLUT - pointer to an array of three bytes.

**Return Value:** ERR\_OK - operation completed with no problems

### **int seGetLutEntry(int index, BYTE \*pEntry)**

**Description:** This routine reads one LUT entry from any index.

A Look-Up Table entry consists of three bytes, one each for Red, Green, and Blue. The color information is stored in the four most significant bits of each byte.

**Parameters:** Index - index to LUT entry (0 to 255)  
pEntry - pointer to an array of three bytes

**Return Value:** ERR\_OK - operation completed with no problems

## 9.5 Porting LIBSE to a new target platform

Building Epson Research and Development applications like a simple HelloApp for a new target platform requires 3 things, the HelloApp code, the 1375HAL library, and a some standard C functions (portable ones are encapsulated in our mini C library LIBSE).

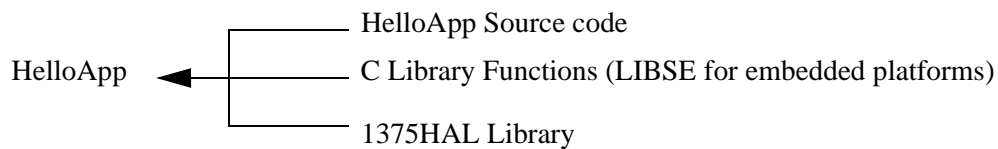

Components needed to build 1375 HAL application

For example, when building HELLOAPP.EXE for the Intel 16-bit platform, you need the HELLOAPP source files, the 1375HAL library and its include files, and some Standard C library functions (which in this case would be supplied by the compiler as part of its runtime library). As this is a DOS .EXE application, you do not need to supply start-up code that sets up the chip selects or interrupts, etc... What if you wanted to build the application for an SH-3 target, one not running DOS?

Before you can build that application to load onto the target, you need to build a C library for the target that contains enough of the Standard C functions (like `sprintf` and `strcpy`) to let you build the application. Epson Research and Development supplies the LIBSE for this purpose, but your compiler may come with one included. You also need to build the 1375HAL library for the target. This library is the graphics chip dependent portion of the code. Finally, you need to build the final application, linked together with the libraries described earlier. The following examples assume that you have a copy of the complete source code for the SED1375 utilities, including the `nmake` makefiles, as well as a copy of the GNU Compiler v2.7-96q3a for Hitachi SH3. These are available on the World Wide Web at <http://www.eea.epson.com>.

### 9.5.1 Building the LIBSE library for SH3 target example

In the LIBSE files, there are three main types of files:

- C files that contain the library functions.
- assembler files that contain the target specific code.
- makefiles that describe the build process to construct the library.

The C files are generic to all platforms, although there are some customizations for targets in the form of `#ifdef LCEVB` code (the `SH3` target Low Cost Eval Board `SH3`). The majority of this code remains constant whichever target you build for.

The assembler files contain some platform setup code (stacks, chip selects) and jumps into the main entry point of the C code that is contained in the C file `entry.c`. For our example, the assembler file is `STARTSH3.S` and it performs only some stack setup and a jump into the code at `_mainEntry` (`entry.c`).

In the embedded targets, `printf` (in file `rprintf.c`), `putchar` (`putchar.c`) and `getch` (`kb.c`) resolve to serial character input/output. For `SH3`, much of the detail of handling serial IO is hidden in the monitor of the evaluation board, but in general the primitives are fairly straight forward, providing the ability to get characters to/from the serial port.

For our target example, the `nmake` makefile is `makesh3.mk`. This makefile calls the Gnu compiler at a specific location (`TOOLDIR`), enumerates the list of files that go into the target and builds a `.a` library file as the output of the build process.

With `nmake.exe` in your path run:

```
nmake -fmakesh3.mk
```

### 9.5.2 Building the HAL library for the target example

Building the HAL for the target example is less complex because the code is written in C and requires little platform specific adjustment. The `nmake` makefile for our example is `makesh3.mk`. This makefile contains the rules for building `sh3` objects, the files list for the library and the library creation rules. The Gnu compiler tools are pointed to by `TOOLDIR`.

With `nmake` in your path run:

```
nmake -fmakesh3.mk
```

## 10 Sample Code

Included in the sample code section are two examples of programming the SED1375. The first sample uses the HAL to draw a red square, wait for user input then rotates to portrait mode and draws a blue square. The second sample code performs the same procedures but directly accesses the registers of the SED1375. These code samples are for example purposes only.

### 10.1 Sample code using the SED1375 HAL API

```

/*
**=====
** SAMPLE1.C - Sample code demonstrating a program using the SED1375 HAL.
**-----
** Created 1998, Vancouver Design Centre
** Copyright (c) 1998, 1999 Epson Research and Development, Inc.
** All Rights Reserved.
**-----
**
** The HAL API code is configured for the following:
**
** 320x240 Single Color 4-bit STN
** 8 bpp - 70 Hz Frame Rate (6 MHz CLKi)
** High Performance enabled
**
**=====
*/
#include <conio.h>
#include <stdio.h>
#include <stdlib.h>
#include <string.h>
#include "hal.h"           /* Structures, constants and prototypes. */
#include "appcfg.h"       /* HAL configuration information. */
/*-----*/
void main(void)
{
    int    ChipId;
    /*
    ** Initialize the HAL.
    ** The call to seRegisterDevice() actually prepares the HAL library
    ** for use. The SED1375 is not accessed, except to read the revision
    ** code register.
    */
    if (ERR_OK != seRegisterDevice(&HalInfo))
    {
        printf("\nERROR: Could not register SED1375 device.");
        exit(1);
    }
}

```



```
/*
** Get the product code to verify this is an SED1375.
*/
seGetId(&ChipId);
if (ID_SED1375_Rev1 != ChipId)
{
    printf("\nERROR: Did not detect an SED1375.");
    exit(1);
}
/*
** Initialize the SED1375.
** This step programs the registers with values taken from
** the HalInfo struct in appcfg.h.
*/
if (ERR_OK != seSetInit())
{
    printf("\nERROR: Could not initialize device.");
    exit(1);
}
/*
** The default initialization cleared the display.
** Draw a 100x100 red (color 1) rectangle in the upper
** left corner (0,0) of the display.
*/
seDrawRect(0, 0, 100, 100, 1, TRUE);
/*
** Pause here.
*/
getch();
/*
** Clear the display. Do this by writing 81920 bytes
*/
seWriteDisplayBytes(0, 0, EIGHTY_K);
/*
** Setup portrait mode.
*/
seSetHWRotate(PORTRAIT);
/*
** Draw a solid blue 100x100 rectangle in center of the display.
** This starting co-ordinates, assuming a 320x240 display is
** (320-100)/2 , (240-100)/2 = 110,70.
*/
seDrawRect(110, 70, 210, 170, 2, TRUE);
/*
** Done!
*/
exit(0);
}
```

## 10.2 Sample code without using the SED1375 HAL API

This second sample demonstrates exactly the same sequence as the first however the HAL is not used, all manipulation is done by directly accessing the registers.

```

/*
**=====
** SAMPLE2.C - Sample code demonstrating a direct access of the SED1375.
**-----
** Created 1998, Vancouver Design Centre
** Copyright (c) 1998, 1999 Epson Research and Development, Inc.
** All Rights Reserved.
**-----
**
** The sample code using direct SED1375 access
** will configure for the following:
**
** 320x240 Single Color 4-bit STN
** 8 bpp color depth - 70 Hz Frame Rate (6 MHz CLKi)
**
** Notes:
** 1) This code is written to be compiled for use under 32-bit
**    Windows. In order to function the vxd file SED13XX.VXD must
**    be in the \WINDOWS\SYSTEM directory.
** 2) Register setup is done with discreet writes rather than being table
**    driven. This allows for clear commenting. It is more efficient to
**    loop through the array writing each element to a control register.
** 3) The array of register values as produced by 1375CFG.EXE is included
**    here. I write the registers directly rather than refer to the register
**    array in the sample code.
**
**=====
*/
#include <conio.h>
#include <windows.h>
#include <winioctl.h>
#include "ioctl.h"
/*
** Look-Up Table - 16 of 256 elements.
** For this sample only the first sixteen LUT elements are set.
*/
unsigned char LUT[16*3] =
{
    0x00, 0x00, 0x00, /* BLACK */
    0x00, 0x00, 0xA0, /* BLUE */
    0x00, 0xA0, 0x00, /* GREEN */
    0x00, 0xA0, 0xA0, /* CYAN */
    0xA0, 0x00, 0x00, /* RED */
    0xA0, 0x00, 0xA0, /* PURPLE */

```

```
    0xA0, 0xA0, 0x00, /* YELLOW */
    0xA0, 0xA0, 0xA0, /* WHITE */
    0x00, 0x00, 0x00, /* BLACK */
    0x00, 0x00, 0xF0, /* LT BLUE */
    0x00, 0xF0, 0x00, /* LT GREEN */
    0x00, 0xF0, 0xF0, /* LT CYAN */
    0xF0, 0x00, 0x00, /* LT RED */
    0xF0, 0x00, 0xF0, /* LT PURPLE */
    0xF0, 0xF0, 0x00, /* LT YELLOW */
    0xF0, 0xF0, 0xF0 /* LT WHITE */
};
/*
** Register data.
** These values were generated using 1375CFG.EXE.
** The sample code uses these values but does not refer to this array.
** In a typical application these values would be written to the registers
** using a loop.
*/
unsigned char Reg[0x20] =
{
    0x00, 0x23, 0xC0, 0x03, 0x27, 0xEF, 0x00, 0x00,
    0x00, 0x00, 0x03, 0x00, 0x00, 0x00, 0x00, 0x00,
    0x00, 0x00, 0xFF, 0x03, 0x00, 0x00, 0x00, 0x00,
    0x00, 0x00, 0x00, 0x00, 0x00
};
#define MEM_SIZE 0x14000 /* 80 kb display buffer. */
typedef unsigned short WORD; /* Some useful types */
typedef unsigned long DWORD;
typedef unsigned char BYTE;
typedef BYTE * PBYTE;
#define LOBYTE(w) ((BYTE)(w))
#define HIBYTE(w) ((BYTE)(((WORD)(w) >> 8) & 0xFF))
#define SET_REG(idx, val) (*(pRegs + idx)) = (val)
/*-----*/
void main(void)
{
    PBYTE p1375;
    PBYTE pRegs;
    PBYTE pMem;
    PBYTE pLUT;
    int x, y, tmp;
    int BitsPerPixel = 8;
    int Width = 320;
    int Height = 240;
    int OffsetBytes;
    int rc;
    /*
    ** Get a linear address we can use in our code to access the SED1375.
    ** This is only needed to access the SED1375 on the ISA eval board.
    */

```

```
*/
DWORD dwLinearAddress;
rc = IntelGetLinAddressW32(0xF00000, &dwLinearAddress);
if (rc != 0)
{
    printf("Error getting linear address");
    return;
}
p1375 = (PBYTE)dwLinearAddress;
pRegs = p1375 + 0x1FFE0;
/*
** Check the revision code. Exit if we don't find an SED1375.
*/
if (0x24 != *pRegs)
{
    printf("Didn't find an SED1375");
    return;
}
/*
** Initialize the chip - after intialization the display will be
** setup for landscape use.
** Normally a loop would be used to write the register array near
** the top of this file to the registers.
** For purposes of documenting the sample code, each register write
** is performed individually.
*/
/*
** Register 01h: Mode Register 0 - Color, 8-bit format 2
*/
SET_REG(0x01, 0x20);
/*
** Register 02h: Mode Register 1 - 8BPP
*/
SET_REG(0x02, 0xC0);
/*
** Register 03h: Mode Register 2 - Normal power mode
*/
SET_REG(0x03, 0x03);
/*
** Register 04h: Horizontal Panel Size - 320 pixels - (320/8)-1 = 39 = 27h
*/
SET_REG(0x04, 0x27);
/*
** Register 05h: Vertical Panel Size LSB - 240 pixels
** Register 06h: Vertical Panel Size MSB - (240 - 1) = 239 = EFh
*/
SET_REG(0x05, 0xEF);
SET_REG(0x06, 0x00);
/*
```

```
** Register 07h - FPLINE Start Position - not used by STN
*/
SET_REG(0x07, 0x00);
/*
** Register 08h - Horizontal Non-Display Period = (Reg[08] + 4) * 8
**                                     = (0+4) * 8 = 32 pels
** - HNDP and VNDP are calculated to achieve the
**   desired frame rate according to:
**
**                                     PCLK
**   Frame Rate = -----
**                 (HDP + HNDP) * (VDP + VNDP)
*/
SET_REG(0x08, 0x00);
/*
** Register 09h - FPFRAME Start Position - not used by STN
*/
SET_REG(0x09, 0x00);
/*
** Register 0Ah - Vertical Non-Display Register = 3 lines
** - Calculated in conjunction with register 08h (HNDP) to
**   achieve the desired frame rate.
*/
SET_REG(0x0A, 0x03);
/*
** Register 0Bh - MOD Rate - not used by this panel
*/
SET_REG(0x0B, 0x00);
/*
** Register 0Ch - Screen 1 Start Word Address LSB
** Register 0Dh - Screen 1 Start Word Address MSB
** - Start address should be set to 0
*/
SET_REG(0x0C, 0x00);
SET_REG(0x0D, 0x00);
/*
** Register 0Eh - Screen 2 Start Word Address LSB
** Register 0Fh - Screen 2 Start Word Address MSB
** - Set this start address to 0 too
*/
SET_REG(0x0E, 0x00);
SET_REG(0x0F, 0x00);
SET_REG(0x10, 0x00); /* Screen1/Screen2 Start Address High bits. */
/*
** Register 11h - Memory Address Offset
** - Used for setting memory to a width greater than the
**   display size. Usually set to 0 during initialization
**   and programmed to desired value later.
*/
```

```
SET_REG(0x11, 0x00);
/*
** Register 12h - Screen 1 Vertical Size LSB
** Register 13h - Screen 1 Vertical Size MSB
**           - Set to maximum (i.e. 0x3FF). This register is used
**           for split screen operation. Normally it is set to
**           maximum value.
*/
SET_REG(0x12, 0xFF);
SET_REG(0x13, 0x03);
/*
** Look-Up Table registers
** The LUT is programmed at the end of the initialization sequence.
*/
/*
** Register 18h - GPIO Configuration - set to 0
**           - '0' configures the GPIO pins for input (power on default)
*/
SET_REG(0x18, 0x00);
/*
** Register 19h - GPIO Status - set to 0
**           - This step has no real purpose. It sets the GPIO
**           pins low should GPIO be set as outputs.
*/
SET_REG(0x19, 0x00);
/*
** Register 1Ah - Scratch Pad - set to 0
**           - Use this register to store whatever state data your
**           system may require.
*/
SET_REG(0x1A, 0x00);
/*
** Register 1Bh - Portrait Mode - set to 0 - disable portrait mode
*/
SET_REG(0x1B, 0x00);
/*
** Register 1Ch - Line Byte Count - set to 0 - used only by portrait mode.
*/
SET_REG(0x0C, 0x00);
/*
** Look-Up Table
** In this example we only set the first sixteen LUT entries.
** In typical use all 256 entries would be setup.
*/
/*
** Register 15h - Look-Up Table Address
**           - Set to 0 to start RGB sequencing at the first LUT entry.
*/
SET_REG(0x15, 0x00);
```

```
/*
** Register 17h - Look-Up Table Data
**           - Write 16 RGB triplets to the LUT.
*/
pLUT = LUT;
for (tmp = 0; tmp < 16; tmp++)
{
    SET_REG(0x17, *pLUT); // Set Red
    pLUT++;
    SET_REG(0x17, *pLUT); // Set Green
    pLUT++;
    SET_REG(0x17, *pLUT); // Set Blue
    pLUT++;
}
/*
** Clear all of video memory by writing 81920 bytes of 0.
*/
pMem = p1375;
for (tmp = 0; tmp < MEM_SIZE; tmp++)
{
    *pMem = 0;
    pMem++;
};
/*
** Draw a 100x100 red rectangle in the upper left corner (0,0)
** of the display.
*/
for (y = 0; y < 100; y++)
{
    /*
    ** Set the memory pointer at the start of each line.
    **   Pointer = MEM_OFFSET + (Y * Line_Width * BPP / 8) + (X * BPP / 8)
    */
    pMem = p1375 + (y * 320 * BitsPerPixel / 8) + 0;
    for (x = 0; x < 100; x++)
    {
        *pMem = 0x4; /* Draw a pixel with LUT color 4 */
        pMem++;
    }
}
/*
** Wait for the user to press a key before continuing.
*/
printf("Press any key to continue");
getch();
/*
** Set and use PORTRAIT mode.
*/
/*
```

```

** Clear the display, and all of video memory, by writing 81920 bytes
** of 0. This is done because an image in display memory is not rotated
** when the switch to portrait display mode occurs.
*/
pMem = p1375;
for (tmp = 0; tmp < MEM_SIZE; tmp++)
{
    *pMem = 0;
    pMem++;
};
/*
** We will use the default portrait mode scheme so we have to adjust
** the ROTATED width to be a power of 2.
** (NOTE: current height will become the rotated width)
*/
tmp = 1;
while (Height > (1 << tmp))
tmp++;
Height = (1 << tmp);
OffsetBytes = Height * BitsPerPixel / 8;
/*
** Set:
** 1) Line Byte Count to size of the ROTATED width (i.e. current height)
** 2) Start Address to the offset of the width of the ROTATED display.
**    (in portrait mode the start address registers point to bytes)
*/
SET_REG(0x1C, (BYTE)OffsetBytes);
OffsetBytes--;
SET_REG(0x0C, LOBYTE(OffsetBytes));
SET_REG(0x0D, HIBYTE(OffsetBytes));
/*
** Set Portrait mode.
** Use the non-X2 (default) scheme so we don't have to re-calc the frame
** rate. MCLK will be <= 25 MHz so we can leave auto-switch enabled.
*/
SET_REG(0x1B, 0x80);
/*
** Draw a solid blue 100x100 rectangle centered on the display.
** Starting co-ordinates, assuming a 320x240 display are:
**    (320-100)/2 , (240-100)/2 = 110,70.
*/
for (y = 70; y < 180; y++)
{
    /*
    ** Set the memory pointer at the start of each line.
    **    Pointer = MEM_OFFSET + (Y * Line_Width * BPP / 8) + (X * BPP / 8)
    ** NOTICE: as this is default portrait mode, the width is a power
    **          of two. In this case, we use a value of 256 pixels for
    **          our calculations instead of the panel dimension of 240.
    */

```



```
    */
    x = 110;
    pMem = p1375 + (y * 256 * BitsPerPixel / 8) + (x * BitsPerPixel / 8);
    for (x = 110; x < 210; x++)
    {
        *pMem = 0x01;          /* Draw a pixel in LUT color 1 */
        pMem++;
    }
}
/*
**=====
**
** IntelGetLinAddressW32(DWORD physaddr,DWORD *linaddr)
**
** return value:
**
**     0 : No error
**    -1 : Error
**
*/
int IntelGetLinAddressW32(DWORD physaddr, DWORD *linaddr)
{
    HANDLE hDriver;
    DWORD  cbReturned;
    int    rc, retVal;
    unsigned Arr[2];
    // First see if we are running under WinNT
    DWORD dwVersion = GetVersion();
    if (dwVersion < 0x80000000)
    {
        hDriver = CreateFile("\\\\.\\SED13xx", GENERIC_READ | GENERIC_WRITE,
                            0, NULL, OPEN_EXISTING, FILE_ATTRIBUTE_NORMAL,
                            NULL);
    }
    else // Win95/98
    {
        // Dynamically load and prepare to call SED13xx.
        // The FILE_FLAG_DELETE_ON_CLOSE flag is used so that CloseHandle can
        // be used to dynamically unload the VxD.
        // The CREATE_NEW flag is not necessary
        hDriver = CreateFile("\\\\.\\SED13xx.VXD", 0,0,0,
                            CREATE_NEW, FILE_FLAG_DELETE_ON_CLOSE, 0);
    }
    if (hDriver == INVALID_HANDLE_VALUE)
        return -1;
    /*
    ** From now on, the code is common for Win95 & WinNT
    */
    if (physaddr == 0)
```

```
        return -1;
Arr[0] = physaddr;
Arr[1] = 4 * 1024 * 1024;
rc = DeviceIoControl(hDriver, IOCTL_SED_MAP_PHYSICAL_MEMORY,
                    &Arr[0], 2 * sizeof(ULONG), &retVal, sizeof(ULONG),
                    &cbReturned, NULL);
if (rc)
    *linaddr = retVal;

/*
** Close the handle.
** This will dynamically UNLOAD the Virtual Device for Win95.
*/
CloseHandle(hDriver);
if (rc)
    return 0;
return -1;
}
```

## 10.3 Header Files

The header files included here are the required for the HAL sample to compile correctly.

```
/*
**=====
** HAL.H - Header file for use with programs written to use the SED1375 HAL.
**-----
** Created 1998, Vancouver Design Centre
** Copyright (c) 1998, 1999 Epson Research and Development, Inc.
** All Rights Reserved.
**=====
*/
#ifndef _HAL_H_
#define _HAL_H_
#include "hal_regs.h"
/*-----*/
typedef unsigned char  BYTE;
typedef unsigned short WORD;
typedef unsigned long  DWORD;
typedef unsigned int   UINT;
typedef          int    BOOL;
#ifdef INTEL
typedef BYTE  far *LPBYTE;
typedef WORD  far *LPWORD;
typedef UINT  far *LPUINT;
typedef DWORD far *LPDWORD;
#else
typedef BYTE      *LPBYTE;
typedef WORD      *LPWORD;
typedef UINT      *LPUINT;
typedef DWORD     *LPDWORD;
#endif
#ifndef LOBYTE
#define LOBYTE(w)    ((BYTE)(w))
#endif
#ifndef HIBYTE
#define HIBYTE(w)    ((BYTE)((((UINT)(w) >> 8) & 0xFF))
#endif
#ifndef LOWORD
#define LOWORD(l)    ((WORD)(DWORD)(l))
#endif
#ifndef HIWORD
#define HIWORD(l)    ((WORD)((((DWORD)(l) >> 16) & 0xFFFF))
#endif
#ifndef MAKEWORD
#define MAKEWORD(lo, hi) ((WORD)((((WORD)(lo) | (((WORD)(hi)) << 8)) )
#endif
#ifndef MAKELONG
```

```

#define MAKELONG(lo, hi) (((long)(((WORD)(lo)) | (((DWORD)((WORD)(hi))) << 16)))
#endif
#ifndef TRUE
#define TRUE 1
#endif
#ifndef FALSE
#define FALSE 0
#endif
#define OFF 0
#define ON 1
#define SCREEN1 1
#define SCREEN22
/*
** Constants for HW rotate support
*/
#define DEFAULT0
#define LANDSCAPE 1
#define PORTRAIT2
#ifndef NULL
#ifdef __cplusplus
#define NULL 0
#else
#define NULL ((void *)0)
#endif
#endif
/*-----*/
/*
** SIZE_VERSION is the size of the version string (eg. "1.00")
** SIZE_STATUS is the size of the status string (eg. "b" for beta)
** SIZE_REVISION is the size of the status revision string (eg. "00")
*/
#define SIZE_VERSION5
#define SIZE_STATUS 2
#define SIZE_REVISION3
#ifdef ENABLE_DPF /* Debug_printf() */
#define DPF(exp) printf(#exp "\n")
#define DPF1(exp) printf(#exp " = %d\n", exp)
#define DPF2(exp1, exp2) printf(#exp1 "=%d " #exp2 "=%d\n", exp1, exp2)
#define DPFL(exp) printf(#exp " = %x\n", exp)
#else
#define DPF(exp) ((void)0)
#define DPF1(exp) ((void)0)
#define DPFL(exp) ((void)0)
#endif
/*-----*/
enum
{
ERR_OK = 0, /* No error, call was successful.
*/

```

```
ERR_FAILED,                                /* General purpose failure.
*/
ERR_UNKNOWN_DEVICE,                        /* */
ERR_INVALID_PARAMETER, /* Function was called with invalid parameter. */
ERR_HAL_BAD_ARG,
ERR_TOOMANY_DEVS
};
/*****
* Definitions for seGetId()
*****/
#define PRODUCT_ID 0x24
enum
{
    ID_UNKNOWN,
    ID_SED1375_Rev1
};
#define MAX_MEM_ADDR81920 - 1
#define EIGHTY_K81920
#define MAX_DEVICE 10
#define SE_RSVD 0
/*****
* Definitions for Internal calculations.
*****/
#define MIN_NON_DISP_X 32
#define MAX_NON_DISP_X 256
#define MIN_NON_DISP_Y 2
#define MAX_NON_DISP_Y 64
enum
{
    RED,
    GREEN,
    BLUE
};
/*****
typedef struct tagHalStruct
{
    char  szIdString[16];
    WORD  wDetectEndian;
    WORD  wSize;
    BYTE  Reg[MAX_REG + 1];
    DWORD dwClkI;      /* Input Clock Frequency (in kHz) */
    DWORD dwDispMem; /* */
    WORD  wFrameRate; /* */
} HAL_STRUCT;
typedef HAL_STRUCT * PHAL_STRUCT;
#ifdef INTEL_16BIT
typedef HAL_STRUCT far * LPHAL_STRUCT;
#else
typedef HAL_STRUCT * LPHAL_STRUCT;
```

```

#endif
/*=====*/
/*          FUNCTION  PROTO-TYPES          */
/*=====*/
/*----- Initialization -----*/
int seRegisterDevice( const LPHAL_STRUCT lpHalInfo );
int seSetInit( void );
int seInitHal( void );
/*----- Miscellaneous -----*/
int  seGetId( int *pId );
void seGetHalVersion( const char **pVersion, const char **pStatus,
                    const char **pStatusRevision );
int seSetBitsPerPixel( int nBitsPerPixel );
int seGetBitsPerPixel( int *pBitsPerPixel );
int seGetBytesPerScanline( int *pBytes );
int seGetScreenSize( int *width, int *height );
void seDelay( int nMilliseconds );
int seGetLastUsableByte( long *LastByte );
int seSetHighPerformance( BOOL OnOff );
/*----- Advanced -----*/
int seSetHWRotate( int nMode );
int seSplitInit( WORD Scrn1Addr, WORD Scrn2Addr );
int seSplitScreen( int WhichScreen, int VisibleScanlines );
int seVirtInit( int xVirt, long *yVirt );
int seVirtMove( int nWhichScreen, int x, int y );
/*----- Register/Memory Access -----*/
int seGetReg( int index, BYTE *pValue );
int seSetReg( int index, BYTE value );
int seReadDisplayByte( DWORD offset, BYTE *pByte );
int seReadDisplayWord( DWORD offset, WORD *pWord );
int seReadDisplayDword( DWORD offset, DWORD *pDword );
int seWriteDisplayBytes( DWORD addr, BYTE val, DWORD count );
int seWriteDisplayWords( DWORD addr, WORD val, DWORD count );
int seWriteDisplayDwords( DWORD addr, DWORD val, DWORD count );
/*----- Power Save -----*/
int seHWSuspend( int nDevID, BOOL val );
int seSetPowerSaveMode( int nDevID, int PowerSaveMode );
/*----- Drawing -----*/
int seDrawLine( int x1, int y1, int x2, int y2, DWORD color );
int seDrawRect( int x1, int y1, int x2, int y2, DWORD color, BOOL Solidfill );
/*----- Color -----*/
int seSetLut( BYTE *pLut );
int seGetLut( BYTE *pLut );
int seSetLutEntry( int index, BYTE *pEntry );
int seGetLutEntry( int index, BYTE *pEntry );
#endif      /* _HAL_H_ */

```

```

/*
**=====
** APPCFG.H - Application configuration information.
**-----
** Created 1998 - Vancouver Design Centre
** Copyright (c) 1998, 1999 Epson Research and Development, Inc.
** All Rights Reserved.
**-----
**
** The data in this file was generated using 1375CFG.EXE.
**
** The configuration parameters chosen were:
** 320x240 Single Color 4-bit STN
** 4 bpp - 100 Hz Frame Rate (12 MHz CLKi)
** High Performance enabled
**
**=====
*/
/*****
/* 1375 HAL HDR (do not remove) */
/* HAL_STRUCT Information generated by 1375CFG.EXE */
/* Copyright (c) 1998 Epson Research and Development, Inc. */
/* All rights reserved. */
/*
/* Include this file ONCE in your primary source file */
/*****
HAL_STRUCT HalInfo =
{
    "1375 HAL EXE", /* ID string */
    0x1234, /* Detect Endian */
    sizeof(HAL_STRUCT), /* Size */
    0x00, 0x20, 0xC0, 0x03, 0x27, 0xEF, 0x00, 0x00,
    0x00, 0x00, 0x03, 0x00, 0x00, 0x00, 0x00, 0x00,
    0x00, 0x00, 0xFF, 0x03, 0x00, 0x00, 0x00, 0x00,
    0x00, 0x00, 0x00, 0x00, 0x00, 0x00, 0x00, 0x00,
    6000, /* ClkI (kHz) */
    0xF00000, /* Display Address */
    70, /* Panel Frame Rate (Hz) */
};

```

```

/*
**=====
**  HAL_REGS.H
**-----
**  Created 1998, Epson Research & Development
**          Vancouver Design Center.
**  Copyright(c) Seiko Epson Corp. 1998.  All rights reserved.
**=====
*/
#ifndef __HAL_REGS_H__
#define __HAL_REGS_H__
/*
**      1375 register names
*/
#define REG_REVISION_CODE          0x00
#define REG_MODE_REGISTER_0       0x01
#define REG_MODE_REGISTER_1       0x02
#define REG_MODE_REGISTER_2       0x03
#define REG_HORZ_PANEL_SIZE        0x04
#define REG_VERT_PANEL_SIZE_LSB    0x05
#define REG_VERT_PANEL_SIZE_MSB    0x06
#define REG_FPLINE_START_POS       0x07
#define REG_HORZ_NONDISP_PERIOD    0x08
#define REG_FPFRAME_START_POS      0x09
#define REG_VERT_NONDISP_PERIOD    0x0A
#define REG_MOD_RATE               0x0B
#define REG_SCRN1_START_ADDR_LSB   0x0C
#define REG_SCRN1_START_ADDR_MSB   0x0D
#define REG_SCRN2_START_ADDR_LSB   0x0E
#define REG_SCRN2_START_ADDR_MSB   0x0F
#define REG_SCRN_START_ADDR_OVERFLOW 0x10
#define REG_MEMORY_ADDR_OFFSET     0x11
#define REG_SCRN1_VERT_SIZE_LSB    0x12
#define REG_SCRN1_VERT_SIZE_MSB    0x13
#define REG_LUT_ADDR               0x15
#define REG_LUT_BANK_SELECT        0x16
#define REG_LUT_DATA               0x17
#define REG_GPIO_CONFIG            0x18
#define REG_GPIO_STATUS            0x19
#define REG_SCRATCHPAD             0x1A
#define REG_PORTRAIT_MODE          0x1B
#define REG_LINE_BYTE_COUNT        0x1C
#define REG_NOT_PRESENT_1         0x1D
/*
** WARNING!!! MAX_REG must be the last available register!!!
*/
#define MAX_REG                    0x1D
#endif /* __HAL_REGS_H__ */

```



```
/*-----  
**  
** Copyright (c) 1998, 1999 Epson Research and Development, Inc.  
** All Rights Reserved.  
**  
** Module Name:  
**  
**     ioctl.h  
**  
**  
** Abstract:  
**  
**     Include file for SED13xx PCI Board Driver.  
**     Define the IOCTL codes we will use.  The IOCTL code contains a command  
**     identifier, plus other information about the device, the type of access  
**     with which the file must have been opened, and the type of buffering.  
**  
**-----  
*/  
  
#define SED_TYPE FILE_DEVICE_CONTROLLER  
// The IOCTL function codes from 0x800 to 0xFFFF are for customer use.  
#define IOCTL_SED_QUERY_NUMBER_OF_PCI_BOARDS \  
    CTL_CODE( SED_TYPE, 0x900, METHOD_BUFFERED, FILE_ANY_ACCESS)  
#define IOCTL_SED_MAP_PCI_BOARD \  
    CTL_CODE( SED_TYPE, 0x901, METHOD_BUFFERED, FILE_ANY_ACCESS)  
#define IOCTL_SED_MAP_PHYSICAL_MEMORY \  
    CTL_CODE( SED_TYPE, 0x902, METHOD_BUFFERED, FILE_ANY_ACCESS)  
#define IOCTL_SED_UNMAP_LINEAR_MEMORY \  
    CTL_CODE( SED_TYPE, 0x903, METHOD_BUFFERED, FILE_ANY_ACCESS)
```

**THIS PAGE LEFT BLANK**

REG[00h] REVISION CODE REGISTER <sup>1</sup> IO address = 1FFE0h <sup>2</sup> , RO						
Product Code = 001001				Revision Code = 00		
Bit 5	Bit 4	Bit 3	Bit 2	Bit 1	Bit 0	

REG[01h] MODE REGISTER 0 IO address = 1FFE1h, RW						
TFT/STN	Dual/Single	Color/Mono <sup>3</sup>	FPLine Polarity	FPPFrame Polarity	Mask FPSHIFT	Data Width <sup>4</sup>
Bit 7	Bit 6	Bit 5	Bit 4	Bit 3	Bit 2	Bit 1

REG[02h] MODE REGISTER 1 IO address = 1FFE2h, RW						
Bit-Per-Pixel <sup>3</sup>	High <sup>5</sup> Performance	Input Clock Div (CLKI/2)	Display Blank	Frame Repeat	Hw Video Invert Enable	Software Video Invert
Bit 1	Bit 0					

REG[03h] MODE REGISTER 2 IO address = 1FFE3h, RW						
n/a	n/a	n/a	n/a	LCDPWR Overide	Hardware PS Enable	Sw Power Save <sup>6</sup>
Bit 7	Bit 6	Bit 5	Bit 4	Bit 3	Bit 2	Bit 1

REG[04h] HORIZONTAL PANEL SIZE REGISTER IO address = 1FFE4h, RW						
n/a	Horizontal Panel Size = 8(REG + 1)					
Bit 7	Bit 6	Bit 5	Bit 4	Bit 3	Bit 2	Bit 1

REG[05h] VERTICAL PANEL SIZE REGISTER (LSB) IO address = 1FFE5h, RW						
Vertical Panel Size = (REG[05h], REG[06h]) + 1						
Bit 7	Bit 6	Bit 5	Bit 4	Bit 3	Bit 2	Bit 1

REG[06h] VERTICAL PANEL SIZE REGISTER (MSB) IO address = 1FFE6h, RW						
n/a	n/a	n/a	n/a	n/a	n/a	Vertical Panel Size
Bit 7	Bit 6	Bit 5	Bit 4	Bit 3	Bit 2	Bit 1

REG[07h] FPLINE START POSITION IO address = 1FFE7h, RW						
n/a	n/a	n/a	FPLine Start Position = 8(REG[07h] + 2)			
Bit 7	Bit 6	Bit 5	Bit 4	Bit 3	Bit 2	Bit 1

REG[08h] HORIZONTAL NON-DISPLAY PERIOD IO address = 1FFE8h, RW						
n/a	n/a	n/a	Horizontal Non-Display Period = 8(REG + 4)			
Bit 7	Bit 6	Bit 5	Bit 4	Bit 3	Bit 2	Bit 1

REG[09h] FPPFRAME START POSITION IO address = 1FFE9h, RW						
n/a	n/a	FPPFrame Start Position				
Bit 7	Bit 6	Bit 5	Bit 4	Bit 3	Bit 2	Bit 1

REG[0Ah] VERTICAL NON-DISPLAY PERIOD REGISTER IO address = 1FFEAh, RW						
Vert Non-Disp Status	n/a	Vertical Non-Display Period				
Bit 7	Bit 6	Bit 5	Bit 4	Bit 3	Bit 2	Bit 1

REG[0Bh] MOD RATE REGISTER IO address = 1FFEBh, RW						
n/a	n/a	MOD Rate				
Bit 7	Bit 6	Bit 5	Bit 4	Bit 3	Bit 2	Bit 1

REG[0Ch] SCREEN 1 START WORD ADDRESS REGISTER (LSB) IO address = 1FFECb, RW						
Screen 1 Start Word Address = (REG[0Ch], REG[0Dh], REG[10] bit 1)						
Bit 7	Bit 6	Bit 5	Bit 4	Bit 3	Bit 2	Bit 1

REG[0Dh] SCREEN 1 START WORD ADDRESS REGISTER (MSB) IO address = 1FFEDb, RW						
Screen 1 Start Word Address						
Bit 15	Bit 14	Bit 13	Bit 12	Bit 11	Bit 10	Bit 9

REG[0Eh] SCREEN 2 START WORD ADDRESS REGISTER (LSB) IO address = 1FFEEh, RW						
Screen 2 Start Word Address = (REG[0E], REG[0Fh], REG[10] bit 4)						
Bit 7	Bit 6	Bit 5	Bit 4	Bit 3	Bit 2	Bit 1

REG[0Fh] SCREEN 2 START WORD ADDRESS REGISTER (MSB) IO address = 1FFEFh, RW						
Screen 2 Start Word Address						
Bit 15	Bit 14	Bit 13	Bit 12	Bit 11	Bit 10	Bit 9

REG[10h] SCREEN START ADDRESS OVERFLOW REGISTER IO address = 1FFF0h, RW						
			Screen 2 Start Add Bit 16			Screen 1 Start Add Bit 16

REG[11h] MEMORY ADDRESS OFFSET REGISTER IO address = 1FFF1h, RW						
Memory Address Offset						
Bit 7	Bit 6	Bit 5	Bit 4	Bit 3	Bit 2	Bit 1

REG[12h] SCREEN 1 VERTICAL SIZE REGISTER (LSB) IO address = 1FFF2h, RW						
Screen 1 Vertical Size = (REG[12h], REG[13h])						
Bit 7	Bit 6	Bit 5	Bit 4	Bit 3	Bit 2	Bit 1

REG[13h] SCREEN 1 VERTICAL SIZE REGISTER (MSB) IO address = 1FFF3h, RW						
n/a	n/a	n/a	n/a	n/a	n/a	Screen 1 Vertical Size
Bit 7	Bit 6	Bit 5	Bit 4	Bit 3	Bit 2	Bit 1

REG[15h] LOOK-UP TABLE ADDRESS REGISTER IO address = 1FFF5h, RW						
Look-Up Table Address						
Bit 7	Bit 6	Bit 5	Bit 4	Bit 3	Bit 2	Bit 1

REG[17h] LOOK-UP TABLE DATA REGISTER IO address = 1FFF7h, RW						
Look-Up Table Data						
Bit 3	Bit 2	Bit 1	Bit 0	n/a	n/a	n/a

REG[18h] GPIO CONFIGURATION CONTROL REGISTER IO address = 1FFF8h, RW						
n/a	n/a	n/a	GPIO4 Pin IO Config	GPIO3 Pin IO Config	GPIO2 Pin IO Config	GPIO1 Pin IO Config
Bit 7	Bit 6	Bit 5	Bit 4	Bit 3	Bit 2	Bit 1

REG[19h] GPIO STATUS / CONTROL REGISTER IO address = 1FFF9h, RW						
n/a	n/a	n/a	GPIO4 Pin IO Status	GPIO3 Pin IO Status	GPIO2 Pin IO Status	GPIO1 Pin IO Status
Bit 7	Bit 6	Bit 5	Bit 4	Bit 3	Bit 2	Bit 1

REG[1Ah] SCRATCH PAD REGISTER IO address = 1FFFAh, RW						
Scratch Pad Register						
Bit 7	Bit 6	Bit 5	Bit 4	Bit 3	Bit 2	Bit 1

REG[1Bh] SWIVELVIEW MODE REGISTER IO address = 1FFFBh, RW						
SwivelView Mode En.	SwivelView Mode Sel.	n/a	n/a	n/a	reserved	SwivelView PCLK Select
Bit 7	Bit 6	Bit 5	Bit 4	Bit 3	Bit 2	Bit 1

REG[1Ch] LINE BYTE COUNT REGISTER IO address = 1FFFCh, RW						
Line Byte Count						
Bit 7	Bit 6	Bit 5	Bit 4	Bit 3	Bit 2	Bit 1

- Notes**  
 1 These bits are used to identify the SED1373 at power on / reset.  
 2 IO addresses are relative to the beginning of display memory.  
 3 Gray Shade/Color Mode Selection

Color/Mono REG[01] bit 5	Bit-Per-Pixel Bit 1 REG[02] bit 7	Bit-Per-Pixel Bit 0 REG[02] bit 6	Display Mode	
1	0	0	2 Colors	1 Bit-Per-Pixel
		1	4 Colors	2 Bit-Per-Pixel
	1	0	16 Colors	4 Bit-Per-Pixel
0	0	1	256 Colors	8 Bit-Per-Pixel
		0	2 Gray Shade	1 Bit-Per-Pixel
	1	0	4 Gray Shade	2 Bit-Per-Pixel
		1	16 Gray Shade	4 Bit-Per-Pixel
		1	reserved	

4 Panel Data Format

TFT/STN REG[01] bit 7	Color/Mono REG[01] bit 5	Dual/Single REG[01] bit 6	Data Width Bit 1 REG[01] bit 1	Data Width Bit 0 REG[01] bit 0	Function	
0	0	0	0	0	Mono Single 4-bit LCD	
			1	1	Mono Single 8-bit LCD	
			0	0	reserved	
			1	1	reserved	
			0	0	reserved	
			1	1	Mono Dual 8-bit LCD	
	1	1	0	0	0	reserved
				1	1	Color Single 4-bit LCD
				0	1	Color Single 8-bit LCD Format 1
				1	0	reserved
				0	1	Color Single 8-bit LCD Format 2
				1	0	reserved
1	don't care	1	0	1	Color Dual 8-bit LCD	
			1	0	reserved	
			0	1	reserved	
			1	0	9 bit TFT Panel	
			0	1	12 bit TFT Panel	
			1	0	reserved	

5 High Performance Selection

High Performance	Bit-Per-Pixel Bit 1 REG[02] bit 7	Bit-Per-Pixel Bit 0 REG[02] bit 6	Display Modes	
0	0	0	MClk = PClk/8	1 bit-per-pixel
		1	MClk = PClk/4	2 bit-per-pixel
	1	0	MClk = PClk/2	4 bit-per-pixel
1	X	1	MClk = PClk	8 bit-per-pixel
		X	MClk = PClk	

6 Power Save Mode Selection

Power Save Bit 1	Power Save Bit 0	Mode
0	0	Power Save Mode 1
0	1	reserved
1	0	reserved
1	1	Normal Operation





## **SED1375 Embedded Memory LCD Controller**

# **1375CFG Configuration Program**

**Document No. X27A-B-001-01**

Copyright © 1999 Epson Research and Development, Inc. All Rights Reserved.

Information in this document is subject to change without notice. You may download and use this document, but only for your own use in evaluating Seiko Epson/EPSON products. You may not modify the document. Epson Research and Development, Inc. disclaims any representation that the contents of this document are accurate or current. The Programs/Technologies described in this document may contain material protected under U.S. and/or International Patent laws.

EPSON is a registered trademark of Seiko Epson Corporation. All other Trademarks are the property of their respective owners

---

**THIS PAGE LEFT BLANK**

---

# Table of Contents

<b>Introduction</b> . . . . .	<b>7</b>
<b>Program Requirements</b> . . . . .	<b>8</b>
Installation . . . . .	8
Usage . . . . .	8
<b>CFG Tab</b> . . . . .	<b>9</b>
Panel Information . . . . .	10
Miscellaneous Options . . . . .	12
System . . . . .	14
LUT Control . . . . .	15
Message Bar . . . . .	16
<b>REGS Tab</b> . . . . .	<b>17</b>
<b>Buttons</b> . . . . .	<b>18</b>
Open . . . . .	18
Save . . . . .	19
Help . . . . .	20
Exit . . . . .	20
<b>Comments</b> . . . . .	<b>21</b>

**THIS PAGE LEFT BLANK**



---

## List of Tables

Table 1:	MCLK to PCLK Ratios . . . . .	13
----------	-------------------------------	----

## List of Figures

Figure 1	CFG Window . . . . .	9
Figure 2	Panel Information . . . . .	10
Figure 3	Miscellaneous Options. . . . .	12
Figure 4	System Options . . . . .	14
Figure 5	ERROR: Frame Rate . . . . .	14
Figure 6	ERROR: Zero Frame Rate. . . . .	15
Figure 7	Look-Up Table Control . . . . .	15
Figure 8	REGS Window . . . . .	17
Figure 9	1375CFG File Open Dialog . . . . .	18
Figure 10	ERROR: Unable to read HAL. . . . .	19
Figure 11	1375CFG Save As Dialog . . . . .	19
Figure 12	ERROR: Unable to read HAL. . . . .	20

**THIS PAGE LEFT BLANK**

---

# Introduction

1375CFG is 32-bit Windows program designed to calculate register values for the SED1375. The user enters data such as the input clock frequency, panel width and height, and other panel specific information. After calculating the register values the information can be used to configure executable files based on the SED1375 Hardware Abstraction Layer (HAL) or written to ASCII text files.

1375CFG can:

- Read programs, based on the SED1375 HAL, modify the settings and write the changes back to the file. The ability to read, modify and write executable files bypasses having to recompile after configuration changes.
- Write C header files containing register settings which then can be used to initialize the SED1375 registers in programs which do not use the HAL.
- Write ASCII text files containing a list of the registers and the register values and the input clock and frame rate the register calculations are based on.

# Program Requirements

This program is designed to run under Windows 95/98 or Windows NT.

## Installation

There is no installation program for 1375CFG. Installation to a local drive is done by copying 1375CFG.EXE and 1375CFG.HLP to your hard drive and optionally creating a link on the Windows desktop for easy access to the program.

## Usage

Open the drive and folder where you copied 1375CFG.EXE and double click the icon to start the program. Optionally, if you created a link to the program on your desktop, double click the link icon.

After starting you will be presented with a tabbed dialog box containing four buttons and two tabs: CFG and REGS. The following sections will describe the using the tabs followed by a description of the buttons.

# CFG Tab

Upon opening 1375CFG the user is present with a window which appears as in Figure 1.

The CFG tab is the dominant portion of the window and consists of four main sections: Panel information (includes Dimensions), Look-Up Table, Miscellaneous Options, and System settings. Each of these sections will be discussed in detail.

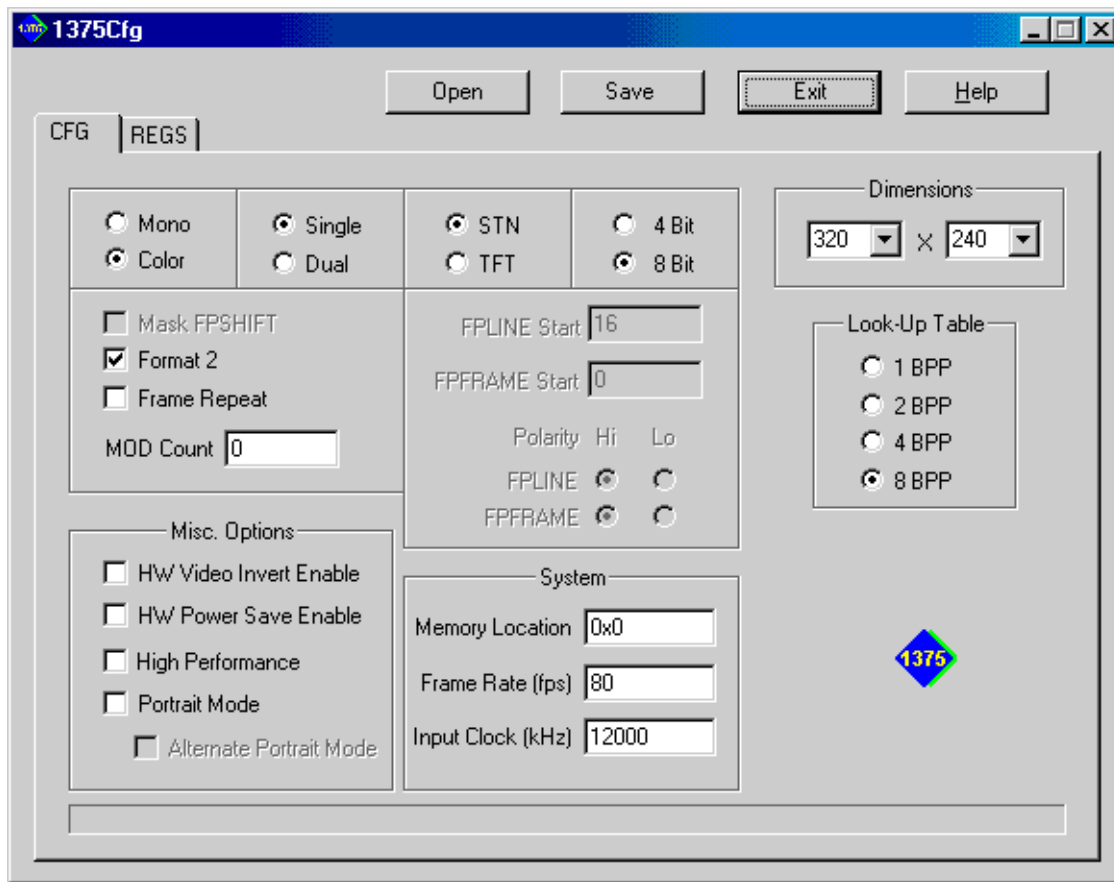

Figure 1 CFG Window

## Panel Information

Figure 2 Panel Information

The panel information portion of CFG tab describes the panel to be connected to the SED1375.

This section of the 1375CFG dialog describes the panel connected to the SED1375. Each of the settings are described briefly below.

- **Mono / Color** - selects whether the attached panel is monochrome or color.

Select mono for monochrome panels or color for color panels. This option is STN specific and is disabled if TFT is selected.

- **Single / Dual** - selects whether the panel is a single STN or dual STN.

Select single for a single panel or dual for a dual panel. This option is STN specific and is disabled if TFT is selected.

- **STN / TFT** - determines the technology used to construct the panel.

Select STN for passive panels or TFT for active panels. Selecting STN enables all the STN options and disables (grays out) the TFT specific settings. Selecting TFT enables the TFT settings and disables STN specific settings.

- **4 Bit / 8 Bit** - these setting select the data width the panel requires.

These radio buttons are STN/TFT specific. When STN is selected the options are “4 Bit” and “8 Bit”. Selecting a TFT type panel changes these options to “9 Bit” and “12 Bit”. Select the data width as appropriate for your panel.

NOTE: panel data width is not the same as color depth.

- **Dimensions** - the two boxes in the upper right corner of the CFG tab allow selecting the panel dimensions.

In the left selection box enter the panel width in pixels and in the right selection box enter the panel height in pixels.

Values in the selection boxes can be either chosen from the drop-down list or typed directly into the edit portion of the selection box.

- **Mask FPSHIFT** - when selected causes the signal FPSHIFT to be masked.

This option is required by most newer monochrome panels. Whenever either color panel or TFT is selected this option is disabled.

- **Format 2** - determines the data clocking format for “8 Bit” single color panels.

8-bit single color panels typically use one of two data clocking formats arbitrarily named “format 1” and “format 2”. Selecting “format 2” instructs the SED1375 to use the second color panel data format.

Most newer panels and, to date, all color panels smaller than 640x480 use “format 2”. Setting this attribute incorrectly will result in a garbled display but will not damage the panel. The display may appear “cut in half” or possibly horizontally skewed.

This option is STN specific and is disabled if TFT is selected. It is also disabled if the panel type selected to be 4-bit data or monochrome.

- **Frame Repeat**- is a feature for EL panel support.

EL panels require a frame of repeated data as the cue to switch polarization. Without this change in polarization panel quality deteriorates.

When Frame Repeat is selected an internal counter causes the periodic repeat of one frame of modulated panel data. At a frame rate of 72 Hz the repeat period is roughly one hour. When not selected the modulated image is never consecutively repeated.

This option is STN specific and is disabled if TFT is selected.

- **MOD Count** - specifies the number of FPLINE pulses between toggles of the MOD signal.

This setting is for passive panels only and is generally only required for older monochrome panels. When set to “0” (default) the MOD output signal toggles every FP-FRAME.

- **FPLINE Start** - specifies the delay, in 8 pixel resolution, from the end of a line of display data (FPDAT) to the leading edge of FPLINE.

This field is a TFT specific setting and is disabled if an STN panel is chosen.

- **FPFRAME Start** - specifies the number of lines between the last line of display data (FPDAT) and the leading edge of FPFRAME.

This field is a TFT specific setting and is disabled if an STN panel is chosen.

- **FPLINE / FPFRAME Polarity** - these settings control the sync pulse direction of the FPLINE and FPFRAME pulses in TFT modes.

Select the appropriate pulse direction for the panel being connected. Selecting 'Lo' results in an active low sync pulse while 'Hi' results in an active high pulse.

These settings are TFT specific and are disabled when STN panel is selected. When an STN panel type is selected the pulse directions are preset to +ve, +ve.

## Miscellaneous Options

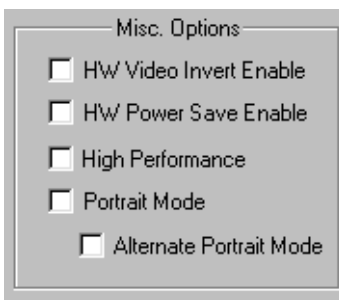

*Figure 3 Miscellaneous Options*

Miscellaneous options cover several items which do not fit into other categories.

- **HW Video Invert Enable**- when selected, enables the hardware video invert capability of the SED1375.

The SED1375 supports inverted color output. The color inversion can be toggled by software or in response to a signal applied to pin FPDAT11. In order for the hardware color inversion to succeed this option must be selected, or the software must enable this feature at run time.

There are two methods of performing color inversion. In the first scheme the display memory data is inverted and the resulting color is derived from the corresponding Look-Up Table element. (i.e. the inverse of color 0 would be whatever color was LUT[FF] was set to. If element 0 and FF were both set to White then we would observe the inverse of white as being white). The second scheme is to invert the data as it comes out of the Look-Up Table resulting in a true color inversion. The SED1375 uses the second method.



TFT panels require all the FPDAT control lines, as a result hardware color inversion is not possible when using TFT panels. Software invoked color inversion can be invoked when using TFT panels.

- **HW Power Save Enable** - select this option to enable hardware invoked power save modes.

The SED1375 supports two means of invoking a power save mode. In response to a software effected change or in response to input on the GPIO0 pin. In order for the hardware power save mode to function this option must be selected.

- **High Performance** - improves chip throughput at the expense of power consumption.

When not selected the memory clock (MCLK) signal is a divided down version of the pixel clock (PCLK) signal. Table 1 depicts the ratios when high performance is not selected.

With slower MCLK selections comes lower performance and also lower power use. This setting allows the user to trade off power consumption for system performance.

*Table 1: MCLK to PCLK Ratios*

Color Depth (bpp)	Ratio
1	MCLK = PCLK / 8
2	MCLK = PCLK / 4
4	MCLK = PCLK / 2
8	MCLK = PCLK

Selecting this option result in MCLK equalling PCLK at all display resolution. Overall performance is increased but so is power consumption.

- **Portrait Mode** - selecting this option causes register settings and timings to be saved for portrait mode operation.
- **Alternate Portrait Mode** - selects the alternate mode.

The SED1375 supports two portrait mode schemes. Default portrait mode offers slightly slower performance with the gain of lower power consumption. Alternate portrait mode is more flexible and slightly faster at the expense of drawing more power.

This option is only enable if Portrait Mode is selected.

NOTE: The portrait mode settings are intended primarily for the case where a developer desires a C header file set of register values for his own program.

The HAL is capable of performing rotations “on the fly”. Most programs written for the HAL will ignore this setting and set Portrait or Landscape display modes as instructed by the user.

## System

The options in the System section describe the items which are required for frame rate calculations and the location in CPU address space where the SED1375 will be located.

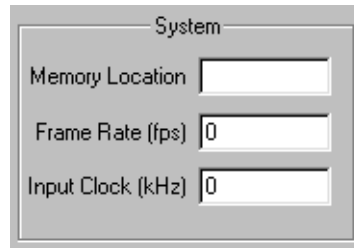

*Figure 4 System Options*

- **Memory Location** - this describes where in CPU address space the SED1375 will be located. This setting is required by the HAL to locate the SED1375.
- **Frame Rate** - indicates the desired frame rate. 1375CFG will attempt to write register settings which result in the requested frame rate. If the frame rate cannot be reached then the following dialog inform the user of the problem.

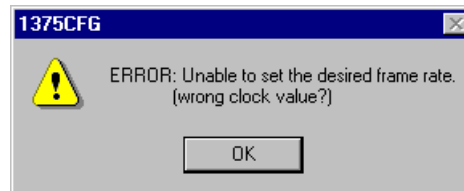

*Figure 5 ERROR: Frame Rate*

A Frame rate must be entered in order for 1375CFG to complete the frame rate calculations. If no frame rate is entered or the frame rate is set to 0 then the following dialog box will inform the user when they try to save the configuration.



Figure 6 ERROR: Zero Frame Rate

- **Input Clock** - this field specifies the input clock being applied to the SED1375 in kHz.

## LUT Control

This section controls the color depth for the SED1375 after initialization.



Figure 7 Look-Up Table Control

Select the desired color depth from the available options.

Color depth selections in this section are enabled or disabled dependent upon the selected panel dimensions. i.e. there is only enough memory to operate a 640x480 panel at 2 bit per pixel so the selections for 4 BPP and 8 BPP would be disabled when this panel size is selected.

NOTE: The primary use for the Look-Up Table color depth settings are for a developer to derive a set of register values for inclusion in a program. Most of the sample programs based on the HAL override the color depth for testing purposes.

## Message Bar



The message bar is used to convey configuration information to the person using 1375CFG. These messages are intended to help the user in derive the best possible configuration. Currently there are three messages which may appear here:

- **Warning: HNDP (???) is getting quite large.**

This message is declaring the Horizontal Non-Display Period is getting quite large. 1375CFG uses a loop to determine the best values for both horizontal and vertical non-display periods. If the horizontal non-display period grows excessively large (greater than 160 pixels) as result of the calculations this message is issued.

Larger HNDP values usually result in fading of the display image. Try increasing the frame rate or reducing the input clock to correct this problem.

This warning may be ignored with the understanding that there may be a display image degradation.

- **Warning: VNDP (???) is getting quite large.**

This message is declaring the Vertical Non-Display Period is getting quite large. The value (???) is the VNDP that 1375 has calculated.

1375CFG uses a loop to determine the best values for both horizontal and vertical non-display periods. If the vertical non-display period grows excessively large (greater than 30 lines) as result of the calculations this message is issued.

Larger VNDP values may result in image tearing, jitter or other display anomalies. Try increasing the frame rate or reducing the input clock to correct this problem.

This warning may be ignored with the understanding that there may be a display image degradation.

- **Warning: unable to set the frame rate based on the current settings.**

Based on the current setting for horizontal and vertical size, input clock and desired frame rate it is not possible to calculate a combination of horizontal and vertical non-display times to satisfy the requested frame rate.

Typical causes for this message are incorrect input clock or frame rate values. The values may be excessively high or excessively low. Correct the suspect value before attempting to save the configuration.

If this warning is ignored it will lead to the message box shown in Figure 5 on page 14 or Figure 6 on page 15 being displayed when the “Save” button is clicked.

# REGS Tab

The REGS tab displays the register values derived after converting the information on the CFG page in to register values.

The automatic calculations may not result in precisely the register values required for a specific use. For instance the HNDDP or VNDDP values may have to be tweaked for a particular panel. From this page the user can set specific register to specific values.

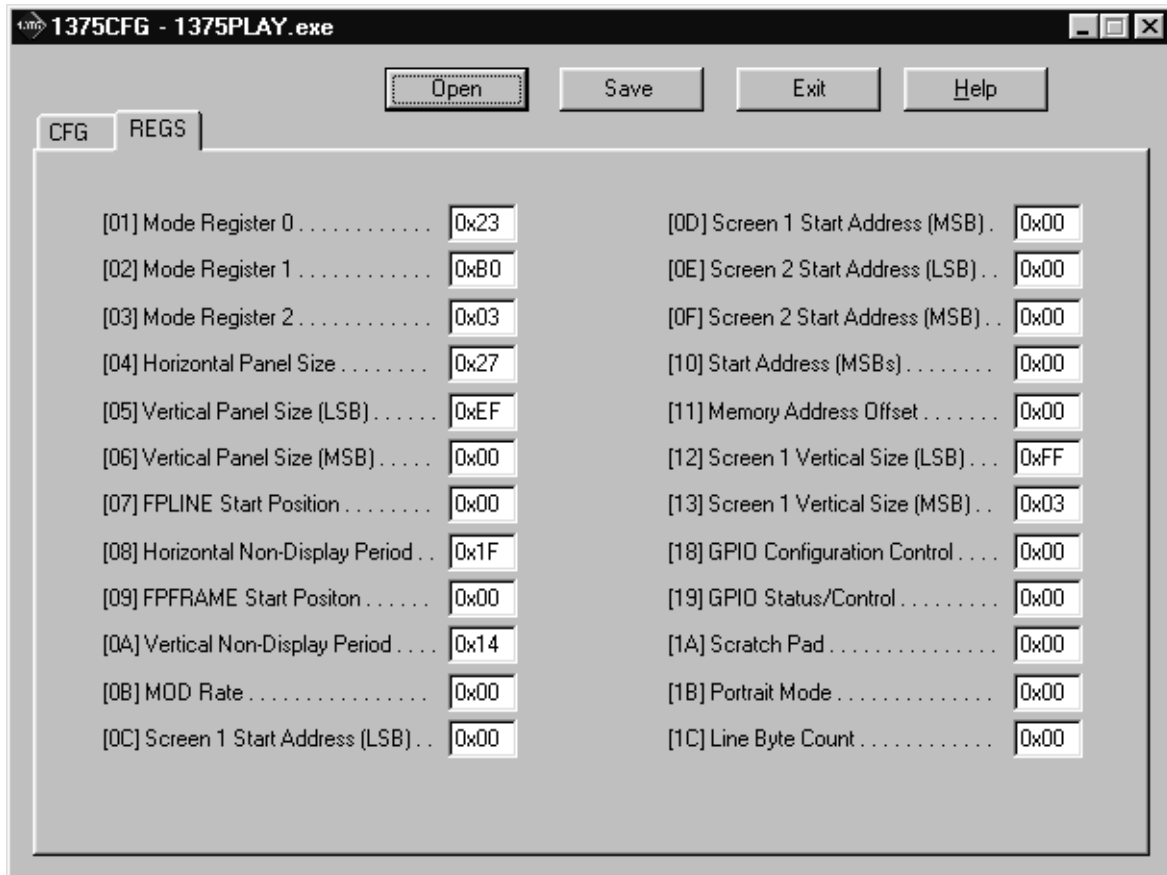

Figure 8 REGS Window

Not all the SED1375 registers are represented on this page. For example; it makes no sense to represent REG[00], the Revision Code, which is read only. Nor are the Look-Up Table registers, REG[15] and REG[17], as they must be specially handled by the application after the majority of the SED1375 registers have been initialized.

Typical use of 1375CFG involves using the CFG page to quickly set register values. After performing the initial setup on the CFG page the user should switch to the REGS page and perform any register adjusting that must be done.

**IMPORTANT:** do *not* return to the CFG page after making register adjustments on this page. Doing so will result in an automatic recalculation of some register values and the possible loss of adjusted settings.

## Buttons

Outside of the page area of 1375CFG there are four buttons for reading and writing files, obtaining help or for exiting the program. The following sections describe these buttons.

### Open

Click the Open button to read the settings saved in an executable program based on the SED1375 hardware abstraction layer.

Clicking the Open button brings up the standard Windows file open dialog.

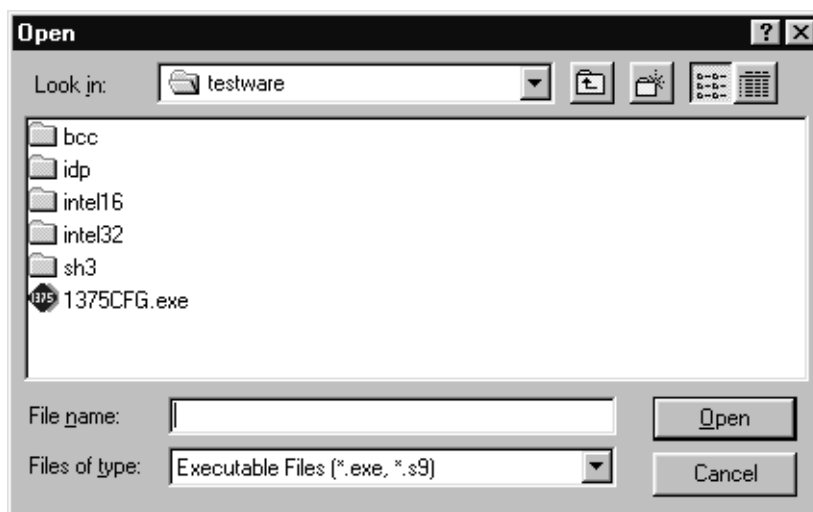

*Figure 9 1375CFG File Open Dialog*

From here the user selects the file to be opened. 1375CFG is capable of opening executable files based on the SED1375 HAL. Typically the file extension for these file are .EXE for intel platform executables and .S9 for 68k and SH3 platform executables.

Opening a file reads that files HAL configuration information. Use the data read as a starting point in configuring this or other files or to check on the current configuration.

If 1375CFG is unable locate the HAL information in the selected file the following dialog box is displayed.

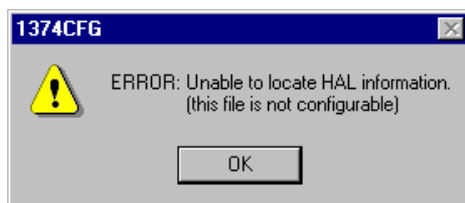

Figure 10 ERROR: Unable to read HAL

## Save

Click the Save button to save the current configuration settings. When clicked the standard Windows file “Save As” dialog box is displayed.

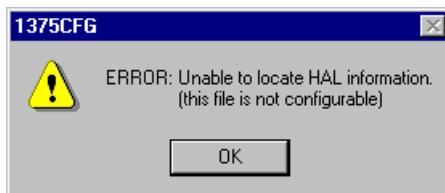

Figure 11 1375CFG Save As Dialog

From the save as dialog box first select the type of file to save to in the “Save as type:” edit field. 1375CFG currently saves in three file formats.

- .EXE files - are binary images containing a HAL structure for execution on Intel platforms
- .S9 files - are ASCII binary format files used by several embedded systems. The .S9 file is a variation of S19 files.
- .H files - are ASCII C header files which can be included in other programs.

If an executable file (.EXE or .S9) is selected as the type of file to save to the file being saved to must already exist and be an SED1375 HAL based program. 1375CFG is cannot save to a non-existent program. If 1375CFG is unable to locate the HAL information in the file being saved to the following dialog box is displayed.



*Figure 12 ERROR: Unable to read HAL*

## Help

Clicking on the Help button will start the help file for SED1375CFG.

## Exit

Clicking on the Exit button exits 1375CFG immediately. The user is not prompted to save any changes they may have made.



## Comments

It is assumed that the 1375CFG user is familiar with SED1375 hardware and software. Refer to the SED1375 “Functional Hardware Specification,” drawing office number X27A-A-001-xx, and the SED1375 “Programming Notes and Examples” manual, drawing office number X27A-G-002-xx for information.

**THIS PAGE LEFT BLANK**



## **SED1375 Embedded Memory LCD Controller**

# **1375SHOW Demonstration Program**

**Document No. X27A-B-002-01**

Copyright © 1999 Epson Research and Development, Inc. All Rights Reserved.

Information in this document is subject to change without notice. You may download and use this document, but only for your own use in evaluating Seiko Epson/EPSON products. You may not modify the document. Epson Research and Development, Inc. disclaims any representation that the contents of this document are accurate or current. The Programs/Technologies described in this document may contain material protected under U.S. and/or International Patent laws.

EPSON is a registered trademark of Seiko Epson Corporation. All other Trademarks are the property of their respective owners

---

**THIS PAGE LEFT BLANK**

# 1375SHOW

1375SHOW is a program designed to demonstrate rudimentary display capabilities of the SED1375. The display abilities are shown by drawing a pattern image to the video display at all supported color depths (1, 2, 4 and 8 bits-per-pixel)

The 1375SHOW display utility must be configured and/or compiled to work with your hardware platform. The program 1375CFG.EXE can be used to configure 1375SHOW. Consult the 1375CFG users guide, document number X27A-B-001-xx, for more information on configuring SED1375 utilities.

This software is designed to work in both embedded and personal computer (PC) environments. For the embedded environment, it is assumed that the system has a means of downloading software from the PC to the target platform. Typically, this is done by serial communications. The PC uses a terminal program to send control commands and information to the target processor. Alternatively, the PC can program an EPROM, which is then placed in the target platform. Some target platforms can also communicate with the PC via a parallel port connection, or an Ethernet connection.

## SED1375 Supported Evaluation Platforms

1375SHOW has been tested with the following SED1375 supported evaluation platforms:

- PC system with an x86 processor. Both 16-bit and 32-bit code is supported.
- M68EC000IDP (Integrated Development Platform) board, revision 3.0, with a Motorola M68EC000 processor.
- SH3-LCEVB board, revision B, with an Hitachi SH-3 HD6417780 processor.

If the platform you are using is different from the above, please see the SED1375 Programming Notes and Examples manual, document number X26A-G-002-xx.

## Installation

### PC Intel Platform

**For 16-Bit Program Version:** copy the file 1375SHOW.EXE to a directory that is in the DOS path on your hard drive.

**For 32-Bit Program Version:** install the 32-bit Windows device driver SED13XX.VXD as described in the SED13XX 32-Bit Windows Device Driver Installation Guide, document number X00A-E-003-xx. Copy the file 1375SHOW.EXE to a directory that is in the DOS path on your hard drive.

### Embedded Platform

Download the program 1375SHOW to the system.

## Usage

**PC platform:** at the prompt, type:

```
1375show [/a][b=n][/l][/p [/alt]][/vertical][/noinit][/?]
```

**Embedded platform:** execute **1375show** and at the prompt, type the command line argument(s).

Where:	/a	automatically cycle through all video modes.
	b=?	starts 1375SHOW at a user specified bit-per-pixel (bpp) level, where ? can be: 1, 2, 4, or 8.
	/l	set landscape mode.
	/p	set portrait mode.
	/alt	use alternate portrait mode
	/vertical	displays vertical line pattern.
	/update	continuously update display memory.
	/noinit	bypass register initialization and use values which are currently in the registers.
	/?	displays the help screen.

## Comments

- The /alt command line switch can only be used with the /p (portrait) mode switch. This switch will have no effect in landscape display modes.
- The Intel 32-bit version of 1375SHOW is designed to work under either Windows 9x or Windows NT. To install the 32-bit Windows device driver SED13XX.vxd see the SED13XX 32-Bit Windows Device Driver Installation Guide, document number X00A-E-003-xx.

The 16-bit version of the program runs under DOS with no DOS extenders. The lack of a DOS extender means that the 16-bit program can only be used on a hardware platform where the SED1375 is addressed below 1MB.

## Program Messages

### **ERROR: Did not find a 1375 device.**

The HAL was unable to read the revision code register on the SED1375. Ensure that the SED1375 hardware is installed and that the hardware platform has been configured correctly. Also check that the display memory address has been configured correctly.

### **ERROR: Unable to locate/load SED13XX.VXD**

1375PLAY was unable to load a required driver. The file SED13XX.VXD should be located in x:\WINDOWS\SYSTEM or in x:\WINNT\SYSTEM. If the file is not there, install it as described in the SED13XX 32-Bit Windows Device Driver Installation Guide, document number X00A-E-003-xx.

### **ERROR: An IOCTL error occurred**

This message indicates an error at the IO control layer occurred. The usual cause for this is an incorrect hardware configuration.

### **ERROR: The HAL returned an unknown error**

This message should never be displayed, it indicates that 1375SHOW is unable to determine the cause of an error returned from the HAL.

### **ERROR: Could not initialize device**

The call to initialize the SED1375 registers failed.

### **Not enough memory for www x hhh x bpp!!**

This message is printed if there is insufficient display memory to show a complete image with a width of www pixels, a height of hhh pixels and a color depth of bpp bit-per-pixel. In this case the mode is skipped and the next display mode is attempted.

**THIS PAGE LEFT BLANK**





## **SED1375 Embedded Memory LCD Controller**

# **1375SPLT Display Utility**

**Document No. X27A-B-003-01**

Copyright © 1999 Epson Research and Development, Inc. All Rights Reserved.

Information in this document is subject to change without notice. You may download and use this document, but only for your own use in evaluating Seiko Epson/EPSON products. You may not modify the document. Epson Research and Development, Inc. disclaims any representation that the contents of this document are accurate or current. The Programs/Technologies described in this document may contain material protected under U.S. and/or International Patent laws.

EPSON is a registered trademark of Seiko Epson Corporation. All other Trademarks are the property of their respective owners

---

**THIS PAGE LEFT BLANK**

# 1375SPLT

1375SPLT demonstrates SED1375 split screen capability by showing two different areas of display memory on the screen simultaneously.

Screen 1 memory is located at the start of the display buffer and is filled with horizontal bars. Screen 2 memory is located immediately after Screen 1 in the display buffer and is filled with vertical bars. On either user input or elapsed time, the line compare register value is changed to adjust the amount of display area taken up by each screen.

The 1375SPLT display utility must be configured and/or compiled to work with your hardware platform. The program 1375CFG.EXE can be used to configure 1375SPLT. Consult the 1375CFG users guide, document number X27A-B-001-xx, for more information on configuring SED1375 utilities.

This software is designed to work in both embedded and personal computer (PC) environments. For the embedded environment, it is assumed that the system has a means of downloading software from the PC to the target platform. Typically, this is done by serial communications. The PC uses a terminal program to send control commands and information to the target processor. Alternatively, the PC can program an EPROM, which is then placed in the target platform. Some target platforms can also communicate with the PC via a parallel port connection, or an Ethernet connection.

## SED1375 Supported Evaluation Platforms

1375SPLT has been tested with the following SED1375 supported evaluation platforms:

- PC system with an x86 processor. Both 16-bit and 32-bit code is supported.
- M68EC000IDP (Integrated Development Platform) board, revision 3.0, with a Motorola M68EC000 processor.
- SH3-LCEVB board, revision B, with an Hitachi SH-3 HD6417780 processor.

If the platform you are using is different from the above, please see the SED1375 Programming Notes and Examples manual, document number X26A-G-002-xx.

## Installation

### PC Intel Platform

**For 16-Bit Program Version:** copy the file 1375SPLT.EXE to a directory that is in the DOS path on your hard drive.

**For 32-Bit Program Version:** install the 32-bit Windows device driver SED13XX.VXD as described in the SED13XX 32-Bit Windows Device Driver Installation Guide, document number X00A-E-003-xx. Copy the file 1375SPLT.EXE to a directory that is in the DOS path on your hard drive.

### Embedded Platform

Download the program 1375SPLT to the system.

## Usage

**PC platform:** at the prompt, type **1375SPLT [/a] [/?]**

**Embedded platform:** execute **1375spl1t** and at the prompt, type the command line argument.

Where:	no argument	enables manual split screen operation
	/a	enables automatic split screen operation (a timer is used to move screen 2)
	/?	display the help screen

After starting 1375SPLT the following keyboard commands are available.

Manual mode:	↑, u	move Screen 2 up
	↓, d	move Screen 2 down
	HOME	covers Screen 1 with Screen 2
	END	displays only Screen 1
Automatic mode:	any key	change the direction of split screen movement (for PC only)
Both modes:	b	changes the color depth (bits-per-pixel)
	ESC	exits 1375SPLT

## 1375SPLT Example

1. Type "1375splt /a" to automatically move the split screen.
2. Press "b" to change the color depth from 1 bit-per-pixel to 2 bit-per-pixel.
3. Repeat step 2 for the remaining color depths (4 and 8 bit-per-pixel).
4. Press <ESC> to exit the program.

## Program Messages

**ERROR: Did not find a 1375 device.**

The HAL was unable to read the revision code register on the SED1375. Ensure that the SED1375 hardware is installed and that the hardware platform has been configured correctly. Also check that the display memory address has been configured correctly.

**ERROR: Unable to locate/load SED13XX.VXD**

1375PLAY was unable to load a required driver. The file SED13XX.VXD should be located in x:\WINDOWS\SYSTEM or in x:\WINNT\SYSTEM. If the file is not there, install it as described in the SED13XX 32-Bit Windows Device Driver Installation Guide, document number X00A-E-003-xx.

**ERROR: An IOCTL error occurred**

This message indicates an error at the IO control layer occurred. The usual cause for this is an incorrect hardware configuration.

**ERROR: The HAL returned an unknown error**

This message should never be displayed, it indicates that 1375SOLT is unable to determine the cause of an error returned from the HAL.

**Not enough memory for www x hhh x bpp!!**

This message is displayed if there is insufficient display memory to contain two complete images with a width of www pixels, a height of hhh pixels, and a color depth of bpp bit-per-pixel. In this case the mode is skipped and the next display mode is attempted.

**THIS PAGE LEFT BLANK**



## **SED1375 Embedded Memory LCD Controller**

# **1375VIRT Display Utility**

**Document No. X27A-B-004-01**

Copyright © 1999 Epson Research and Development, Inc. All Rights Reserved.

Information in this document is subject to change without notice. You may download and use this document, but only for your own use in evaluating Seiko Epson/EPSON products. You may not modify the document. Epson Research and Development, Inc. disclaims any representation that the contents of this document are accurate or current. The Programs/Technologies described in this document may contain material protected under U.S. and/or International Patent laws.

EPSON is a registered trademark of Seiko Epson Corporation. All other Trademarks are the property of their respective owners

---

**THIS PAGE LEFT BLANK**



# 1375VIRT

1375VIRT demonstrates the virtual display capability of the SED1375. A virtual display is where the image to be displayed is larger than the physical display device. The display surface is used as a viewing window. The entire image can be seen only by panning and scrolling.

The 1375VIRT display utility must be configured and/or compiled to work with your hardware platform. The program 1375CFG.EXE can be used to configure 1375VIRT. Consult the 1375CFG users guide, document number X27A-B-001-xx, for more information on configuring SED1375 utilities.

This software is designed to work in both embedded and personal computer (PC) environments. For the embedded environment, it is assumed that the system has a means of downloading software from the PC to the target platform. Typically, this is done by serial communications. The PC uses a terminal program to send control commands and information to the target processor. Alternatively, the PC can program an EPROM, which is then placed in the target platform. Some target platforms can also communicate with the PC via a parallel port connection, or an Ethernet connection.

## SED1375 Supported Evaluation Platforms

1375VIRT has been tested with the following SED1375 supported evaluation platforms:

- PC system with an x86 processor.
- M68EC000IDP (Integrated Development Platform) board, revision 3.0, with a Motorola M68EC000 processor.
- SH3-LCEVB board, revision B, with an Hitachi SH-3 HD6417780 processor.

If the platform you are using is different from the above, please see the SED1375 Programming Notes and Examples manual, document number X26A-G-002-xx.

## Installation

### PC Intel Platform

**For 16-Bit Program Version:** copy the file 1375VIRT.EXE to a directory that is in the DOS path on your hard drive.

**For 32-Bit Program Version:** install the 32-bit Windows device driver SED13XX.VXD as described in the SED13XX 32-Bit Windows Device Driver Installation Guide, document number X00A-E-003-xx. Copy the file 1375VIRT.EXE to a directory that is in the DOS path on your hard drive.

### Embedded Platform

Download the program 1375VIRT to the system.

## Usage

**PC platform:** at the prompt, type `1375virt [/a] [/l] [/p] [/alt] [/w=???`.

**Embedded platform:** execute `1375virt` and at the prompt, type the command line argument.

Where:	no argument	panning and scrolling is performed manually (defaults to virtual width = physical width x 2 and maximum virtual height)
	/a	panning and scrolling is performed automatically
	/l	Force landscape display mode to be set
	/p	Force portrait display mode to be set
	/alt	Enable alternate portrait mode. Selecting this option implies /p
	/w=???	specifies the virtual display width which includes both on-screen and off-screen size
		the maximum virtual width, not including display area, for each display mode is:
		1 bpp – 4096 pixels
		2 bpp – 2048 pixels
		4 bpp – 1024 pixels
		8 bpp – 512 pixels

The following keyboard commands are for navigation within the program.

Manual mode:	↑	scrolls up
	↓	scrolls down
	←	pans to the left
	→	pans to the right
	HOME	moves the display screen so that the upper right of the virtual screen shows in the upper right of the display
	END	moves the display screen so that the lower left of the virtual screen shows in the lower left of the display
Automatic mode:	any key	changes the direction of screen
Both modes:	b	changes the color depth (bits-per-pixel)
	ESC	exits 1375VIRT

## 1375VIRT Example

1. Type "1375virt /a" to automatically pan and scroll.
2. Press "b" to change the bits-per-pixel from 1 bit-per-pixel to 2 bits-per-pixel.
3. Repeat steps 1 and 2 for the remaining color depths (4 and 8 bit-per-pixel).
4. Press <ESC> to exit the program.

## Program Messages

**ERROR: Did not find a 1375 device.**

The HAL was unable to read the revision code register on the SED1375. Ensure that the SED1375 hardware is installed and that the hardware platform has been configured correctly. Also check that the display memory address has been configured correctly.

**ERROR: Unable to locate/load SED13XX.VXD**

1375PLAY was unable to load a required driver. The file SED13XX.VXD should be located in x:\WINDOWS\SYSTEM or in x:\WINNT\SYSTEM. If the file is not there, install it as described in the SED13XX 32-Bit Windows Device Driver Installation Guide, document number X00A-E-003-xx.

**ERROR: An IOCTL error occurred**

This message indicates an error at the IO control layer occurred. The usual cause for this is an incorrect hardware configuration.

**ERROR: The HAL returned an unknown error**

This message should never be displayed, it indicates that 1375VIRT is unable to determine the cause of an error returned from the HAL.

**Unable to use virtual mode at xx BPP**

This message is displayed if there is insufficient display memory to show a complete virtual image. Specifically, the maximum number of lines for the image is calculated using the current virtual width. If the number of possible lines is less than the physical display size this message is displayed. Try restarting the program and manually specify a smaller virtual width.



## **SED1375 Embedded Memory LCD Controller**

# **1375PLAY Diagnostic Utility**

**Document No. X25A-B-005-02**

Copyright © 1999 Epson Research and Development, Inc. All Rights Reserved.

Information in this document is subject to change without notice. You may download and use this document, but only for your own use in evaluating Seiko Epson/EPSON products. You may not modify the document. Epson Research and Development, Inc. disclaims any representation that the contents of this document are accurate or current. The Programs/Technologies described in this document may contain material protected under U.S. and/or International Patent laws.

EPSON is a registered trademark of Seiko Epson Corporation. All other Trademarks are the property of their respective owners

---

**THIS PAGE LEFT BLANK**

# 1375PLAY

1375PLAY is a utility which allows the user to easily read/write the SED1375 registers, Look-Up Table and display memory.

The user interface for 1375PLAY is similar to the DOS DEBUG program; commands are received from the standard input device, and output is sent to the standard output device (console for Intel and terminal for embedded platforms). This utility requires the target platform to support standard IO.

1375PLAY commands can be entered interactively using a keyboard/monitor or they can be executed from a script file. Scripting is a powerful feature which allows command sequences played back from a file thus avoiding having to retype lengthy sequences.

The 1375PLAY display utility must be configured and/or compiled to work with your hardware platform. The program 1375CFG.EXE can be used to configure 1375PLAY. Consult the 1375CFG users guide, document number X27A-B-001-xx, for more information on configuring SED1375 utilities.

This software is designed to work in both embedded and personal computer (PC) environments. For the embedded environment, it is assumed that the system has a means of downloading software from the PC to the target platform. Typically, this is done by serial communications. The PC uses a terminal program to send control commands and information to the target processor. Alternatively, the PC can program an EPROM, which is then placed in the target platform. Some target platforms can also communicate with the PC via a parallel port connection, or an Ethernet connection.

## SED1375 Supported Evaluation Platforms

1375PLAY has been tested with the following SED1375 supported evaluation platforms:

- PC system with an x86 processor. Both 16-bit and 32-bit code is supported.
- M68EC000IDP (Integrated Development Platform) board, revision 3.0, with a Motorola M68EC000 processor.
- SH3-LCEVB board, revision B, with an Hitachi SH-3 HD6417780 processor.

If the platform you are using is different from the above, please see the SED1375 Programming Notes and Examples manual, document number X26A-G-002-xx.

## Installation

### PC Intel Platform

**For 16-Bit Program Version:** copy the file 1375PLAY.EXE to a directory that is in the DOS path on your hard drive.

**For 32-Bit Program Version:** install the 32-bit Windows device driver SED13XX.VXD as described in the SED13XX 32-Bit Windows Device Driver Installation Guide, document number X00A-E-003-xx. Copy the file 1375PLAY.EXE to a directory that is in the DOS path on your hard drive.

### Embedded Platform

Download the program 1375PLAY to the system.

## Usage

**PC platform:** at the prompt, type **1375play [/?]**.

**Embedded platform:** execute **1375play** and at the prompt, type the command line argument.

Where: **/?** displays program revision information.

The following commands are valid within the 1375PLAY program.

<code>X index [data]</code>	Reads/writes the registers.  Writes data to the register specified by the index when “data” is specified; otherwise the register is read.
<code>XA</code>	Reads all registers.
<code>L index [data1 data2 data3]</code>	Reads/writes Look-Up Table (LUT) values. Writes data to the LUT index when “data” is specified; otherwise the LUT index is read. Data must consist of 3 bytes: 1 red, 1 green, 1 blue. and range in value from 0x00 to 0x0F.
<code>LA</code>	Reads all LUT values.
<code>F[W] addr1 addr2 data . . .</code>	Fills bytes or words from address 1 to address 2 with data. Data can be multiple values (e.g. <code>F 0 20 1 2 3 4</code> fills address 0 to 0x20 with a repeating pattern of 1 2 3 4).



R[W] addr [count]	Reads “count” of bytes or words from the address specified by “addr”. If “count” is not specified, then 16 bytes/words are read.
W[W] addr data . . .	Writes bytes or words of data to address specified by “addr”. Data can be multiple values e.g. W 0 1 2 3 4 writes the byte values 1 2 3 4 starting at address 0).
I	Initializes the chip with user specified configuration.
M [bpp]	Returns information about the current mode. If “bpp” is specified then set the requested color depth.
P 0 1 2	Sets software power save mode 0-2. Power save mode 0 is normal operation.
H [lines]	Halts after specified lines of display. This feature halts the display during long read operations to prevent data from scrolling off the display. Set 0 to disable.
Q	Quits this utility.
?	Displays Help information.

## 1375PLAY Example

1. Type “1375PLAY” to start the program.
2. Type “?” for help.
3. Type “i” to initialize the registers.
4. Type “xa” to display the contents of the registers.
5. Type “x 5” to read register 5.
6. Type “x 3 10” to write 10 hex to register 3.
7. Type “f 0 400 aa” to fill the first 400 hex bytes of display memory with AA hex.
8. Type “f 0 14000 aa” to fill 80k bytes of display memory with AA hex.
9. Type “r 0 ff” to read the first 100 hex bytes of display memory.
10. Type “q” to exit the program.

## Scripting

1375PLAY can be driven by a script file. This is useful when:

- there is no standard display output to monitor command entry and results.
- various registers must be quickly changed faster than can be achieved by typing.
- The same series of keystrokes is being entered time and again.

A script file is an ASCII text file with one 1375PLAY command per line. All scripts must end with a “q” (quit) command in order to return control to the operating system. The semi-colon is used as a comment delimiter. Everything on a line after the semi-colon will be ignored.

On a PC platform, a typical script command line is: “1375PLAY < dumpregs.scr > results”.

This causes the script file “dumpregs.scr” to be interpreted and the results to be sent to the file “results.”

**Example 1:** *The script file “dumpregs.scr” can be created with a text editor and will look like the following:*

```
; This file initializes the SED1375 and reads the registers  
i           ; Initialize the registers.  
xa        ; Dump all the registers  
la        ; And the LUT  
q         ; Exit
```

## Comments

- All numeric values are considered to be hexadecimal unless identified otherwise. For example, 10 = 10h = 16 decimal; 10t = 10 decimal; 010b = 2 decimal.
- Redirecting commands from a script file (PC platform) allows those commands to be executed as though they were typed.

---

## Program Messages

>>> **WARNING: DID NOT DETECT SED1375** <<<

The HAL was unable to read the revision code register on the SED1375. Ensure that the SED1375 hardware is installed and that the hardware platform has been configured correctly. Also check that the display memory address has been configured correctly.

**ERROR: Unable to locate/load SED13XX.VXD**

1375PLAY was unable to load a required driver. The file SED13XX.VXD should be located in x:\WINDOWS\SYSTEM or in x:\WINNT\SYSTEM. If the file is not there, install it as described in the SED13XX 32-Bit Windows Device Driver Installation Guide, document number X00A-E-003-xx.

**ERROR: An IOCTL error occurred**

This message indicates an error at the IO control layer occurred. The usual cause for this is an incorrect hardware configuration.

**ERROR: The HAL returned an unknown error**

This message should never be displayed, it indicates that 1375SHOW is unable to determine the cause of an error returned from the HAL.

**THIS PAGE LEFT BLANK**



## **SED1375 Embedded Memory LCD Controller**

# **1375BMP Demonstration Program**

**Document No. X27A-B-006-02**

Copyright © 1999 Epson Research and Development, Inc. All Rights Reserved.

Information in this document is subject to change without notice. You may download and use this document, but only for your own use in evaluating Seiko Epson/EPSON products. You may not modify the document. Epson Research and Development, Inc. disclaims any representation that the contents of this document are accurate or current. The Programs/Technologies described in this document may contain material protected under U.S. and/or International Patent laws.

EPSON is a registered trademark of Seiko Epson Corporation. All other Trademarks are the property of their respective owners

---

**THIS PAGE LEFT BLANK**

# 1375BMP

1375BMP is a demonstration program for the SED1375 which can read and display .BMP format (Windows bitmap) files.

The 1375BMP display utility is designed to operate on an x86 based personal computer. There are both 16-bit and 32-bit versions of 1375BMP. The 16-bit version is for use under DOS when the SED1375 evaluation board has been configured for D0000. The 32-bit version is intended for use under Win32. Before use 1375BMP must be configured for the display system. Consult documentation for the program 1375CFG.EXE which can be used to configure 1375BMP.

1375BMP is not supported on non-PC platforms.

## Installation

**For 16-Bit Program Version:** copy the file 1375BMP.EXE to a directory that is in the DOS path on your hard drive.

**For 32-Bit Program Version:** install the 32-bit Windows device driver SED13XX.VXD as described in the SED13XX 32-Bit Windows Device Driver Installation Guide, document number X00A-E-003-xx. Copy the file 1375BMP.EXE to a directory that is in the DOS path on your hard drive.

## Usage

At the prompt, type:

```
1375bmp bmp_file [/a[time]] [/l] [/p] [/noinit] [/?].
```

Where: `bmp_file` the name of the file to display

`/a[time]` automatic mode returns to the operating system after “time” seconds. If time is not specified the default is 5 seconds. This option is intended for use with batch files to automate displaying a series of images.

`/l` override default configuration settings and set landscape display mode.

`/p` override default configuration settings and set portrait display mode.

`/noinit` bypass the register initialization and use the current setup  
use this option to override changes that take place to the timing registers

`/?` displays the Help screen

## Comments

- 1375BMP currently views only Windows BMP format images.

## Program Messages

**ERROR: Did not find an SED1375 device.**

The HAL was unable to locate an SED1375 at the configured address. Check that the correct physical address was configured into 1375BMP.EXE

**ERROR: Unable to locate/load SED13XX.VXD**

The file SED13XX.VXD is required by the 32-bit version of the 1375BMP. Check that the .VXD file is in c:\WINDOWS\SYSTEM. If the file is not there, install it as described in the SED13XX 32-Bit Windows Device Driver Installation Guide, document number X00A-E-003-xx.

**ERROR: An IOCTL error occurred.**

The device driver SED13XX.VXD was unable to assign memory. Check that the PC hardware is configured correctly and that 1375BMP has been configured with the correct memory location.

**ERROR: The HAL returned an unknown error.**

This error message should never be seen. **Contact ERD.**

**ERROR: Could not initialize device.**

The HAL failed to initialize the SED1375.

**Failed to open .BMP file '?.....?'**

1375BMP was unable to open the .BMP file ?.....? specified on the command line.

**?.....? is not a valid bitmap file.**

While performing validity checks it was determined that the file ?.....? is either not a valid .BMP file or is of an unsupported format.

**ERROR: Unable to set a suitable display mode.**

1375BMP was unable to set a display mode to view the image with.

**ERROR: Currently unable to process images greater than 8 bpp.**

1375BMP can decode images of 8BPP or less color depth. Try reducing the color depth of your image.

**ERROR: Image larger than display memory size.**

The amount of memory required by this image is more than the amount of memory available to the SED1375. Try choosing a smaller image.

**ERROR: Unable to allocate enough memory to decode the image.**

In order to decode a .BMP image 1375BMP needs to allocate some additional system memory. This message is seen if the call to allocate additional memory fails.





**SED1375 Embedded Memory LCD Controller**

# **1375PWR Power Save Utility**

**Document No. X27A-B-007-01**

Copyright © 1999 Epson Research and Development, Inc. All Rights Reserved.

Information in this document is subject to change without notice. You may download and use this document, but only for your own use in evaluating Seiko Epson/EPSON products. You may not modify the document. Epson Research and Development, Inc. disclaims any representation that the contents of this document are accurate or current. The Programs/Technologies described in this document may contain material protected under U.S. and/or International Patent laws.

EPSON is a registered trademark of Seiko Epson Corporation. All other Trademarks are the property of their respective owners

---

**THIS PAGE LEFT BLANK**

# 1375PWR

The 1375PWR Power Save Utility is a tool to assist in the testing of the software and hardware power save modes.

Refer to the section titled “Power Save Modes” in the SED1375 Programming Notes and Examples manual, document number X26A-G-002-xx, and the SED1375 Functional Hardware Specification, document number X26A-A-001-xx for further information.

The 1375PWR utility must be configured and/or compiled to work with your hardware platform. Consult documentation for the program 1375CFG.EXE which can be used to configure 1375PWR.

This software is designed to work in both embedded and personal computer (PC) environments. For the embedded environment, it is assumed that the system has a means of downloading software from the PC to the target platform. Typically this is done by serial communications, where the PC uses a terminal program to send control commands and information to the target processor. Alternatively, the PC can program an EPROM, which is then placed in the target platform. Some target platforms can also communicate with the PC via a parallel port connection, or an Ethernet connection.

## SED1375 Supported Evaluation Platforms

1375PWR has been designed to work with the following SED1375 supported evaluation platforms:

- PC system with an x86 processor. Both 16-bit and 32-bit code is supported.
- M68EC000IDP (Integrated Development Platform) board, revision 3.0, with a Motorola M68EC000 processor.
- SH3-LCEVB board, revision B, with an Hitachi SH-3 HD6417780 processor.

If the platform you are using is different from the above, please see the SED1375 “Programming Notes and Examples” manual, document number X26A-G-002-xx.

## Installation

### PC Platform

**For 16-Bit Program Version:** copy the file 1375PWR.EXE to a directory that is in the DOS path on your hard drive.

**For 32-Bit Program Version:** install the 32-bit Windows device driver SED13XX.VXD as described in the SED13XX 32-Bit Windows Device Driver Installation Guide, document number X00A-E-003-xx. Copy the file 1375PWR.EXE to a directory that is in the DOS path on your hard drive.

### Embedded Platform

Download the program 1375PWR to the system.

## Usage

**PC platform:** at the prompt, type **1375pwr [s0] [s1] [h0] [h1]**.

**Embedded platform:** execute 1375pwr and at the prompt, type the command line argument.

Where:

- s0 resets software power save mode
- s1 sets software power save mode
- h0 resets (disables) hardware power save mode (REG[03h] bit 2)
- h1 sets (enables) hardware power save mode (REG[03h] bit 2)
- /? displays this usage message

## Program Messages

### **ERROR: Did not find a 1375 device.**

The HAL was unable to read the revision code register on the SED1375. Ensure that the SED1375 hardware is installed and that the hardware platform has been configured correctly. Also check that the display memory address has been configured correctly.

### **ERROR: Unable to locate/load SED13XX.VXD**

1375PLAY was unable to load a required driver. The file SED13XX.VXD should be located in x:\WINDOWS\SYSTEM or in x:\WINNT\SYSTEM. If the file is not there, install it as described in the SED13XX 32-Bit Windows Device Driver Installation Guide, document number X00A-E-003-xx.

### **ERROR: An IOCTL error occurred**

This message indicates an error at the IO control layer occurred. The usual cause for this is an incorrect hardware configuration.

### **ERROR: The HAL returned an unknown error**

This message should never be displayed, it indicates that 1375SHOW is unable to determine the cause of an error returned from the HAL.

### **Software Power Save Mode set.**

This message is a confirmation that the register setting to enable software power save mode has been set.

### **Software Power Save Mode reset.**

This message is a confirmation that the register setting to disable software power save mode has been set.

### **Hardware Power Save Mode is now Enabled.**

This message confirms that hardware initiated power save mode has been enabled. The SED1375 will enter a hardware power save mode upon application of the appropriate logic level to the hardware power save mode input pin.

### **Hardware Power Save Mode is now Disabled.**

This message confirms that the register setting to disable hardware initiated power save mode has been set. In this state the SED1375 should ignore the state of the hardware power save mode input pin.

**THIS PAGE LEFT BLANK**

# EPSON®



## SED1375 Embedded Memory LCD Controller

# Windows® CE Display Drivers

Document Number: X27A-E-001-01

Copyright © 1999 Epson Research and Development, Inc. All Rights Reserved.

Information in this document is subject to change without notice. You may download and use this document, but only for your own use in evaluating Seiko Epson/EPSON products. You may not modify the document. Epson Research and Development, Inc. disclaims any representation that the contents of this document are accurate or current. The Programs/Technologies described in this document may contain material protected under U.S. and/or International Patent laws.

EPSON is a registered trademark of Seiko Epson Corporation. All other trademarks are the property of their respective owners. Microsoft and Windows are registered trademarks of Microsoft Corporation.

---

**THIS PAGE LEFT BLANK**



# WINDOWS® CE DISPLAY DRIVERS

The Windows CE display drivers are designed to support the SED1375 Embedded Memory LCD Controller running under the Microsoft Windows CE operating system. Available drivers include: 4 and 8 bit-per-pixel landscape modes, and 4 and 8 bit-per-pixel portrait modes.

For updated source code, visit Epson Electronics America on the World Wide Web at [www.eea.epson.com](http://www.eea.epson.com).

## Program Requirements

<b>Video Controller</b>	: SED1375
<b>Display Type</b>	: LCD or CRT
<b>Windows Version</b>	: CE Versions 2.0 thru 2.11

## Example Driver Builds

### Build For CEPC (X86) for Windows CE Versions 2.0 thru 2.1

To build a Windows CE v2.0 or v2.1 display driver for the CEPC (X86) platform using an SDU1375B0C evaluation board, follow the instructions below:

1. Install Microsoft Windows NT v4.0.
2. Install Microsoft Visual C/C++ v5.0.
3. Install the Microsoft Windows CE Embedded Toolkit (ETK) by running SETUP.EXE from the ETK compact disc #1.
4. Create a new project by following the procedure documented in "Creating a New Project Directory" from the Windows CE ETK v2.0. Alternately, use the current "DEMO7" project included with the ETK v2.0. Follow the steps below to create a "X86 DEMO7" shortcut on the Windows NT v4.0 desktop which uses the current "DEMO7" project:
  - a. Right click on the "Start" menu on the taskbar.
  - b. Click on the item "Open All Users" and the "Start Menu" window will come up.
  - c. Click on the icon "Programs".
  - d. Click on the icon "Windows CE Embedded Development Kit".
  - e. Drag the icon "X86 DEMO1" onto the desktop using the right mouse button.
  - f. Click on "Copy Here".

- g. Rename the icon “X86 DEMO1” on the desktop to “X86 DEMO7” by right clicking on the icon and choosing “rename”.
  - h. Right click on the icon “X86 DEMO7” and click on “Properties” to bring up the “X86 DEMO7 Properties” window.
  - i. Replace the string “DEMO1” under the entry “Target” with “DEMO7”.
  - j. Click on “OK” to finish.
5. Create a sub-directory named 8BPP1375 under \wince\platform\cepc\drivers\display.
  6. Copy the source code to the 8BPP1375 subdirectory.
  7. Add an entry for the 8BPP1375 in the file \wince\platform\cepc\drivers\display\dirs.
  8. Since the SDU1375B0C maps memory to 0xF00000, the CEPC machine should use the CMOS setup to create a 1M byte hole from address 0xF00000 to 0xFFFFF.
  9. Edit the file PLATFORM.BIB (located in X:\wince\platform\cepc\files) to set add the display driver 8BPP1375.DLL. 8BPP1375.DLL will be created during the build in step 11.

Add the following lines in PLATFORM.BIB:

```
IF CEPC_DDI_8BPP1375
ddi.dll      $_FLATRELEASEDIR)\8BPP1375.dll  NK SH
ENDIF
```

before these lines:

```
IF CEPC_DDI_VGA2BPP
ddi.dll      $_FLATRELEASEDIR)\ddi_vga2.dll  NK SH
ENDIF
IF CEPC_DDI_VGA8BPP
ddi.dll      $_FLATRELEASEDIR)\ddi_vga8.dll  NK SH
ENDIF
```

and this line:

```
IF CEPC_DDI_8BPP1375 !
```

before these lines that test before dropping into the default display driver:

```
IF CEPC_DDI_VGA2BPP !
IF CEPC_DDI_VGA8BPP !
ddi.dll      $_FLATRELEASEDIR)\ddi_s364.dll  NK SH
ENDIF
ENDIF
```

and finally to match the added IF:

```
ENDIF
```

10. Generate the proper building environment by double-clicking on the sample project icon (i.e. X86 DEMO7).
11. Type BLDDemo <ENTER> at the DOS prompt of the X86 DEMO7 window to generate a Windows CE image file (NK.BIN).

### **Build For CEPC (X86) for Windows CE Version 2.11 (Platform Builder)**

To build a Windows CE v2.11 display driver for the CEPC (X86) platform using an SDU1375B0C evaluation board, follow the instructions below:

1. Install Microsoft Windows NT v4.0.
2. Install Microsoft Visual C/C++ v5.0.
3. Install Platform Builder 2.11.
4. Create a backup copy of the MAXALL.BAT by duplicating the MAXALL.BAT file in Windows NT Explorer, then add an environment variable to select the 8BPP1375 driver.
  - a. Change to the \WINCE211\PUBLIC\MAXALL directory.
  - b. Click on the file MAXALL.BAT, then right click and Copy the MAXALL.BAT file (\WINCE211\PUBLIC\MAXALL\MAXALL.BAT).
  - c. Right click again and select Paste in this same directory. A new file called "Copy of MAXALL" will appear, this is a backup of the original file.
  - d. Edit the file MAXALL.BAT by right clicking and selecting Edit, and add the following lines to the end of the file (Note that the line "set WINCEREL=1" fixes a problem with some versions of Platform Builder):

```
@echo on
set WINCEREL=1
set CEPC_DDI_8BPP1375=1
@echo off.
```
5. Install 1375 CEPC driver
  - a. copy 1375 driver into  
\WINCE211\PLATFORM\CEPC\DRIVERS\DISPLAY\8BPP1375
  - b. add 8BPP1375 into the directory list in file  
\WINCE211\PLATFORM\CEPC\DRIVERS\DISPLAY\dirs

6. Edit the file PLATFORM.BIB (located in X:\wince211\platform\cepc\files) to add a display driver for 8BPP1375.DLL. 8BPP1375.DLL will be created during the build in step 9.

Add the following lines in PLATFORM.BIB:

```
IF CEPC_DDI_8BPP1375
ddi.dll$(_FLATRELEASEDIR)\8BPP1375.dllNK SH
ENDIF
```

before these lines:

```
IF CEPC_DDI_VGA8BPP
ddi.dll      $(_FLATRELEASEDIR)\ddi_vga8.dll  NK SH
ENDIF
```

and this line:

```
IF CEPC_DDI_8BPP1375 !
```

before these lines that test before dropping into the default display driver:

```
IF CEPC_DDI_VGA8BPP !
ddi.dll      $(_FLATRELEASEDIR)\ddi_s364.dll  NK SH
ENDIF
```

and finally add an ENDIF after the first ENDIF to match the added IF:

```
ENDIF
```

7. Cleanup platform builder as normal (remove the \wince211\release directory and delete \wince211\platform\cepc\\*.bif).
8. Generate the proper building environment by selecting “Build Maxall for x86” from the Start Menu. You should see an echo of the lines added earlier to MAXALL.BAT:

```
set WINCEREL=1
set CEPC_DDI_8BPP1375=1
```

9. Type BLDDEMO <ENTER> at the DOS prompt of the “Build Maxall for x86” window to generate a Windows CE image file (NK.BIN).

## Example Installation

### Installation for CEPC Environment

Windows CE v2.0 can be loaded on a PC using a floppy drive or a hard drive. The two methods are described below:

1. To load CEPC from a floppy drive:
  - a. Create a DOS bootable floppy disk.
  - b. Edit CONFIG.SYS on the floppy disk to contain the following line only.  
device=a:\himem.sys
  - c. Edit AUTOEXEC.BAT on the floppy disk to contain the following lines.  
mode com1:9600,n,8,1  
loadcepc /B:9600 /C:1 /D:2 c:\wince\release\nk.bin
  - d. Copy LOADCEPC.EXE from c:\wince\public\common\oak\bin to the bootable floppy disk.
  - e. Confirm that NK.BIN is located in c:\wince\release.
  - f. Reboot the system from the bootable floppy disk.
2. To load CEPC from a hard drive:
  - a. Copy LOADCEPC.EXE to the root directory of the hard drive.
  - b. Edit CONFIG.SYS on the hard drive to contain the following line only.  
device=c:\himem.sys
  - c. Edit AUTOEXEC.BAT on the hard drive to contain the following lines.  
mode com1:9600,n,8,1  
loadcepc /B:9600 /C:1 /D:2 c:\wince\release\nk.bin
  - d. Confirm that NK.BIN is located in c:\wince\release.
  - e. Reboot the system from the hard drive.

## Comments

- Alternatively, in the examples above, you could substitute 4BPP instead of 8BPP.
- On some CEPC systems creating the 1M byte address hole will cause LOADCEPC.EXE to fail. In this case contact your Sales Representative for a newer version of LOADCEPC.EXE called LOAD211X.EXE.

**THIS PAGE LEFT BLANK**

# EPSON®



## SED13XX 32-Bit Windows Device Driver Installation Guide

Document No. X00A-E-003-01

Copyright © 1999 Epson Research and Development, Inc. All Rights Reserved.

Information in this document is subject to change without notice. You may download and use this document, but only for your own use in evaluating Seiko Epson/EPSON products. You may not modify the document. Epson Research and Development, Inc. disclaims any representation that the contents of this document are accurate or current. The Programs/Technologies described in this document may contain material protected under U.S. and/or International Patent laws.

EPSON is a registered trademark of Seiko Epson Corporation. All Trademarks are the property of their respective owners

---

**THIS PAGE LEFT BLANK**



# SED13XX 32-Bit Windows Device Driver Installation Guide

This manual describes the installation of the Windows 95/98 and Windows NT device drivers for the SED13xxB0x series of Epson Evaluation Boards.

The file SED13XX.VXD is required for using the Epson supplied Intel32 evaluation and test programs for the SED13xx family of LCD controllers.

For updated drivers, ask your Sales Representative or visit Epson Electronics America on the World Wide Web at [www.eea.epson.com](http://www.eea.epson.com).

## Driver Requirements

<b>Video Controller</b>	: SED13xx
<b>Display Type</b>	: N/A
<b>BIOS</b>	: N/A
<b>DOS Program</b>	: No
<b>Dos Version</b>	: N/A
<b>Windows Program</b>	: Yes, Windows 95 / Windows 98 / Windows NT 4.0 device driver
<b>Windows DOS Box</b>	: N/A
<b>Windows Full Screen</b>	: N/A
<b>OS/2</b>	: N/A

## Installation

### Windows NT Version 4.0

#### Note

All evaluation boards require the driver to be installed as described in the following.

1. Install the evaluation board in the computer and boot the computer.
2. Copy the files SED13XX.INF and SED13XX.SYS to a directory on a local hard drive.
3. Right click your mouse on the file SED13XX.INF and select INSTALL from the menu.
4. Windows will install the device driver and ask you to restart.

## Windows 98

### All PCI Bus Evaluation Cards

1. Install the evaluation board in the computer and boot the computer.
2. Windows will detect the new hardware as a new PCI Device and bring up the ADD NEW HARDWARE dialog box.
3. Click NEXT
4. Windows will look for the driver. When Windows does not find the driver it will allow you to specify the location of it. Type the driver location or select BROWSE to find it.
5. Click NEXT
6. Windows 98 will locate the specified file and show it as EPSON SED13XX PCI Bridge Card
7. Click FINISH

### All ISA Bus Evaluation Cards

1. Install the evaluation board in the computer and boot the computer.
2. Go to the CONTROL PANEL and select ADD NEW HARDWARE. Windows 98 will attempt to detect any new plug and play device and fail.
3. When the dialog box DETECT NON-PNP HARDWARE appears, select NO for WINDOWS DETECT and click NEXT.
4. Select OTHER HARDWARE DEVICES from HARDWARE TYPES and click NEXT.
5. Click HAVE DISK.
6. Specify the location of the driver files and click OK.
7. Select EPSON 13XX and Click NEXT.
8. Click FINISH.

#### Alternative Installation for ISA Bus Evaluation Cards

Copy the files SED13XX.INF and SED13XX.SYS to the WINDOWS\SYSTEM directory on your hard drive.

## Windows 95 OSR2

### All PCI Bus Evaluation Cards

1. Install the evaluation board in the computer and boot the computer.
2. Windows will detect the card as a new PCI Device and launch the UPDATE DEVICE DRIVER wizard.

#### If The Driver is on Floppy Disk

3. Place the disk into drive A: and click NEXT.
4. Windows will find the EPSON SED13XX PCI Adapter Card.
5. Click FINISH to install the driver
6. Windows will ask you to restart the system.

#### If The Driver is not on Floppy Disk

7. Click NEXT, Windows will search the floppy drive and fail.
8. Windows will attempt to load the new hardware as a Standard VGA Card.
9. Click CANCEL. The Driver must be loaded from the CONTROL PANEL under ADD/NEW HARDWARE.
10. Select NO for Windows to DETECT NEW HARDWARE.
11. Click NEXT.
12. Select OTHER DEVICES from HARDWARE TYPE and Click NEXT.
13. Click HAVE DISK.
14. Specify the location of the driver and click OK
15. Click OK
16. EPSON SED13XX PCI Bridge Card will appear in the list.
17. Click NEXT
18. Windows will install the driver
19. Click FINISH
20. Windows will ask you to restart the system.
21. Windows will re-detect the card and ask you to restart the system.

## All ISA Bus Evaluation Cards

1. Install the evaluation board in the computer and boot the computer.
2. Go to the CONTROL PANEL and select ADD NEW HARDWARE.
3. Click NEXT.
4. Select NO and click NEXT.
5. Select OTHER DEVICES and click NEXT.
6. Click Have Disk.
7. Specify the location of the driver files and click OK.
8. Click Next.
9. Click Finish.

### Alternative Installation for ISA Bus Evaluation Cards

Copy the files SED13XX.INF and SED13XX.SYS to the WINDOWS\SYSTEM directory on your hard drive.

## Previous Versions of Windows 95

### All PCI Bus Evaluation Cards

1. Install the evaluation board in the computer and boot the computer.
2. Windows will detect the card.
3. Select DRIVER FROM DISK PROVIDED BY MANUFACTURER.
4. Click OK
5. Specify a path to the location of the driver files.
6. Click OK
7. Windows will find the SED13XX.INF file.
8. Click OK
9. Click OK and Windows will install the driver

---

## All ISA Bus Evaluation Cards

1. Install the evaluation board in the computer and boot the computer.
2. Go to the CONTROL PANEL and select ADD NEW HARDWARE.
3. Click NEXT.
4. Select NO and click NEXT.
5. Select OTHER DEVICES from the HARDWARE TYPES list.
6. Click HAVE DISK.
7. Specify the location of the driver files and click OK.
8. Select the file SED13XX.INF and click OK.
9. Click OK.
10. The EPSON 13XX should be selected in the list window.
11. Click NEXT
12. Click NEXT
13. Click Finish.

### Alternative Installation for ISA Bus Evaluation Cards

Copy the files SED13XX.INF and SED13XX.SYS to the WINDOWS\SYSTEM directory on your hard drive.

**THIS PAGE LEFT BLANK**



**SED1375 Embedded Memory LCD Controller**

# **SDU1375B0C Rev. 1.0 ISA Bus Evaluation Board User Manual**

**Document Number: X27A-G-005-01**

Copyright © 1999 Epson Research and Development, Inc. All Rights Reserved.

Information in this document is subject to change without notice. You may download and use this document, but only for your own use in evaluating Seiko Epson/EPSON products. You may not modify the document. Epson Research and Development, Inc. disclaims any representation that the contents of this document are accurate or current. The Programs/Technologies described in this document may contain material protected under U.S. and/or International Patent laws.

EPSON is a registered trademark of Seiko Epson Corporation. All other trademarks are the property of their respective owners.

---

**THIS PAGE LEFT BLANK**



# Table of Contents

<b>1</b>	<b>Introduction</b>	<b>7</b>
1.1	Features	7
<b>2</b>	<b>Installation and Configuration</b>	<b>8</b>
<b>3</b>	<b>LCD Interface Pin Mapping</b>	<b>10</b>
<b>4</b>	<b>CPU/Bus Interface Connector Pinouts</b>	<b>11</b>
<b>5</b>	<b>Host Bus Interface Pin Mapping</b>	<b>13</b>
<b>6</b>	<b>Technical Description</b>	<b>14</b>
6.1	Embedded Memory Support	14
6.2	ISA Bus Support	15
6.2.1	Display Adapter Card Support	15
6.2.2	Expanded Memory Manager Support	15
6.3	Non-ISA Bus Support	15
6.4	Decoding Logic	16
6.5	Clock Input Support	16
6.6	LCD Panel Voltage Setting	17
6.7	Monochrome LCD Panel Support	17
6.8	Color Passive LCD Panel Support	17
6.9	Color TFT/D-TFD LCD Panel Support	17
6.10	Power Save Modes	17
6.11	Adjustable LCD Panel Negative Power Supply	18
6.12	Adjustable LCD Panel Positive Power Supply	18
6.13	CPU/Bus Interface Header Strips	18
<b>7</b>	<b>Parts List</b>	<b>19</b>
<b>8</b>	<b>Schematic Diagrams</b>	<b>20</b>

**THIS PAGE LEFT BLANK**

---

## List of Tables

Table 2-1: Configuration DIP Switch Settings . . . . .	8
Table 2-2: Host Bus Selection . . . . .	8
Table 2-3: Jumper Settings . . . . .	9
Table 3-1: LCD Signal Connector (J5) Pinout . . . . .	10
Table 4-1: CPU/BUS Connector (H1) Pinout . . . . .	11
Table 4-2: CPU/BUS Connector (H2) Pinout . . . . .	12
Table 5-1: Host Bus Interface Pin Mapping . . . . .	13

## List of Figures

Figure 8-1: SED1375B0C Schematic Diagram (1 of 4) . . . . .	20
Figure 8-2: SED1375B0C Schematic Diagram (2 of 4) . . . . .	21
Figure 8-3: SED1375B0C Schematic Diagram (3 of 4) . . . . .	22
Figure 8-4: SED1375B0C Schematic Diagram (4 of 4) . . . . .	23

**THIS PAGE LEFT BLANK**

# 1 Introduction

This manual describes the setup and operation of the SDU1375B0C Rev. 1.0 Evaluation Board. Implemented using the SED1375 Embedded Memory Color LCD Controller, the SDU1375B0C board is designed for the 16-bit ISA bus environment. To accommodate other bus architectures, the SDU1375B0C board also provides CPU/Bus interface connectors.

For more information regarding the SED1375, refer to the SED1375 Hardware Functional Specification, document number X27A-A-001-xx.

## 1.1 Features

- 80-pin QFP14 package.
- SMT technology for all appropriate devices.
- 4/8-bit monochrome and color passive LCD panel support.
- 9/12-bit LCD TFT/D-TFD panel support.
- Selectable 3.3V or 5V LCD panel support.
- Oscillator support for CLKI (up to 50MHz with internal clock divider or 25MHz with no internal clock divider).
- Embedded 80K byte SRAM display buffer for 1/2/4 bit-per-pixel (bpp), 2/4/16-level gray shade display and 1/2/4/8 bpp, 2/4/16/256 level color display.
- Support for software and hardware power save modes.
- On-board adjustable LCD bias positive power supply (+23V to +40V).
- On-board adjustable LCD bias negative power supply (-23V to -14V).
- 16-bit ISA bus support.
- CPU/Bus interface header strips for non-ISA bus support.

## 2 Installation and Configuration

The SED1375 has four configuration inputs, CNF[3:0], which are read on the rising edge of RESET# and are fully configurable on this evaluation board. One six-position DIP switch is provided on the board to configure the four configuration inputs, select the SDU1375B0C memory/register start address, and enable/disable hardware power save mode.

The following settings are recommended when using the SDU1375B0C with the ISA bus.

*Table 2-1: Configuration DIP Switch Settings*

Switch	Signal	Closed (0 or low)	Open (1 or high)
S1-1	CNF0	See "Host Bus Selection" table below	See "Host Bus Selection" table below
S1-2	CNF1		
S1-3	CNF2		
S1-4	CNF3	Little Endian	Big Endian
S1-5	ADDR	Memory/Register Start Address = C0000h	Memory/Register Start Address = F00000h
S1-6	GPIO0	Hardware Suspend Disable	Hardware Suspend Enable

= recommended settings (configured for ISA bus support)

*Table 2-2: Host Bus Selection*

S1-3	S1-2	S1-1	BS#	Host Bus Interface
0	0	0	X	SH-4 bus interface
0	0	1	X	SH-3 bus interface
0	1	0	X	reserved
0	1	1	X	MC68K bus interface #1, 16-bit
1	0	0	X	reserved
1	0	1	X	MC68K bus interface #2, 16-bit
1	1	0	0	reserved
1	1	0	1	reserved
1	1	1	0	Generic #1, 16-bit
1	1	1	1	Generic #2, 16-bit

= recommended settings (configured for ISA bus support)

*Table 2-3: Jumper Settings*

	<b>Description</b>	<b>1-2</b>	<b>2-3</b>
JP1	IOVDD Selection	5.0V IOVDD	3.3V IOVDD
JP2	BS# Signal Selection	Pulled up to IOVDD	No Connection
JP3	RD/WR# Signal Selection	Pulled up to IOVDD	No Connection
JP4	LCD Panel Voltage Selection	5V LCD Panel	3.3V LCD Panel
JP5	LCDPWR polarity	Active low ('LCDPWR#')	Active high ('LCDPWR')

 = recommended settings (JP1 through JP3 configured for ISA bus support)

### 3 LCD Interface Pin Mapping

Table 3-1: LCD Signal Connector (J5) Pinout

Connector		Single Passive Panel					Dual Passive Panel		Color TFT/D-TFD	
Pin Name	Pin #	Color			Mono		Color	Mono	9-bit	12-bit
		4-bit	8-bit	8-bit Alternate Format	4-bit	8-bit	8-bit	8-bit		
BFPDAT0	1	driven 0	D0	LD0	driven 0	D0	D0	LD0	R2	R3
BFPDAT1	3	driven 0	D1	LD1	driven 0	D1	D1	LD1	R1	R2
BFPDAT2	5	driven 0	D2	LD2	driven 0	D2	D2	LD2	R0	R1
BFPDAT3	7	driven 0	D3	LD3	driven 0	D3	D3	LD3	G2	G3
BFPDAT4	9	D0	D4	UD0	D0	D4	D4	UD0	G1	G2
BFPDAT5	11	D1	D5	UD1	D1	D5	D5	UD1	G0	G1
BFPDAT6	13	D2	D6	UD2	D2	D6	D6	UD2	B2	B3
BFPDAT7	15	D3	D7	UD3	D3	D7	D7	UD3	B1	B2
BFPDAT8	17	GPIO1	GPIO1	GPIO1	GPIO1	GPIO1	GPIO1	GPIO1	B0	B1
BFPDAT9	19	GPIO2	GPIO2	GPIO2	GPIO2	GPIO2	GPIO2	GPIO2	GPIO2	R0
BFPDAT10	21	GPIO3	GPIO3	GPIO3	GPIO3	GPIO3	GPIO3	GPIO3	GPIO3	G0
BFPDAT11	23	GPIO4/ Inverse Video	GPIO4/ Inverse Video	GPIO4/ Inverse Video	GPIO4/ Inverse Video	GPIO4/ Inverse Video	GPIO4/ Inverse Video	GPIO4/ Inverse Video	GPIO4	B0
BFPSHIFT	33	FPSHIFT	FPSHIFT	FPSHIFT	FPSHIFT	FPSHIFT	FPSHIFT	FPSHIFT	FPSHIFT	FPSHIFT
BFPSHIFT2	35		FPSHIFT2							
BFPLINE	37	FPLINE	FPLINE	FPLINE	FPLINE	FPLINE	FPLINE	FPLINE	FPLINE	FPLINE
BFPFRAME	39	FPFRAME	FPFRAME	FPFRAME	FPFRAME	FPFRAME	FPFRAME	FPFRAME	FPFRAME	FPFRAME
GND	2-26 (Even Pins)	GND	GND	GND	GND	GND	GND	GND	GND	GND
N / C	28									
VLCD	30	LCD panel negative bias voltage (-24V to -14V)								
LCDVCC	32	+3.3V or +5V (selectable with JP4)								
+12V	34	+12V	+12V	+12V	+12V	+12V	+12V	+12V	+12V	+12V
VDDH	36	LCD panel positive bias voltage (+23V to +40V)								
BDRDY	38	MOD		MOD	MOD	MOD	MOD	MOD	DRDY	DRDY
BLCDPWR	40	LCDPWR	LCDPWR	LCDPWR	LCDPWR	LCDPWR	LCDPWR	LCDPWR	LCDPWR	LCDPWR

#### Note

1. Un-used GPIO pins must be connected to IO  $V_{DD}$ .
2. Inverse Video is enabled on FPDAT11 by REG[02h] bit 1.



## 4 CPU/Bus Interface Connector Pinouts

Table 4-1: CPU/BUS Connector (H1) Pinout

Connector Pin No.	CPU/BUS Pin Name	Comments
1	SD0	Connected to DB0 of the SED1375
2	SD1	Connected to DB1 of the SED1375
3	SD2	Connected to DB2 of the SED1375
4	SD3	Connected to DB3 of the SED1375
5	GND	Ground
6	GND	Ground
7	SD4	Connected to DB4 of the SED1375
8	SD5	Connected to DB5 of the SED1375
9	SD6	Connected to DB6 of the SED1375
10	SD7	Connected to DB7 of the SED1375
11	GND	Ground
12	GND	Ground
13	SD8	Connected to DB8 of the SED1375
14	SD9	Connected to DB9 of the SED1375
15	SD10	Connected to DB10 of the SED1375
16	SD11	Connected to DB11 of the SED1375
17	GND	Ground
18	GND	Ground
19	SD12	Connected to DB12 of the SED1375
20	SD13	Connected to DB13 of the SED1375
21	SD14	Connected to DB14 of the SED1375
22	SD15	Connected to DB15 of the SED1375
23	RESET#	Connected to the RESET# signal of the SED1375
24	GND	Ground
25	GND	Ground
26	GND	Ground
27	+12V	12 volt supply
28	+12V	12 volt supply
29	WE0#	Connected to the WE0# signal of the SED1375
30	WAIT#	Connected to the WAIT# signal of the SED1375
31	CS#	Connected to the CS# signal of the SED1375
32	NC	Not connected
33	WE1#	Connected to the WE1# signal of the SED1375
34	IOVDD	Connected to the IOVDD supply of the SED1375

Table 4-2: CPU/BUS Connector (H2) Pinout

Connector Pin No.	CPU/BUS Pin Name	Comments
1	SA0	Connected to AB0 of the SED1375
2	SA1	Connected to AB1 of the SED1375
3	SA2	Connected to AB2 of the SED1375
4	SA3	Connected to AB3 of the SED1375
5	SA4	Connected to AB4 of the SED1375
6	SA5	Connected to AB5 of the SED1375
7	SA6	Connected to AB6 of the SED1375
8	SA7	Connected to AB7 of the SED1375
9	GND	Ground
10	GND	Ground
11	SA8	Connected to AB8 of the SED1375
12	SA9	Connected to AB9 of the SED1375
13	SA10	Connected to AB10 of the SED1375
14	SA11	Connected to AB11 of the SED1375
15	SA12	Connected to AB12 of the SED1375
16	SA13	Connected to AB13 of the SED1375
17	GND	Ground
18	GND	Ground
19	SA14	Connected to AB14 of the SED1375
20	SA15	Connected to AB14 of the SED1375
21	SA16	Connected to AB16 of the SED1375
22	SA17	Connected to SA17 of the ISA bus connector
23	SA18	Connected to SA18 of the ISA bus connector
24	SA19	Connected to SA19 of the ISA bus connector
25	GND	Ground
26	GND	Ground
27	VCC	5 volt supply
28	VCC	5 volt supply
29	RD/WR#	Connected to the R/W# signal of the SED1375
30	BS#	Connected to the BS# signal of the SED1375
31	BUSCLK	Connected to the BCLK signal of the SED1375
32	RD#	Connected to the RD# signal of the SED1375
33	NC	Not connected
34	CLKI	Connected to the CLKI signal of the SED1375

## 5 Host Bus Interface Pin Mapping

Table 5-1: Host Bus Interface Pin Mapping

SED1375 Pin Names	SH-3	SH-4	MC68K #1	MC68K #2	Generic Bus #1	Generic Bus #2
AB[16:1]	A[16:1]	A[16:1]	A[16:1]	A[16:1]	A[16:1]	A[16:1]
AB0	A0	A0	LDS#	A0	A0	A0
DB[15:0]	D[15:0]	D[15:0]	D[15:0]	D[15:0]	D[15:0]	D[15:0]
WE1#	WE1#	WE1#	UDS#	DS#	WE1#	BHE#
CS#	CSn#	CSn#	External Decode	External Decode	External Decode	External Decode
BCLK	CKIO	CKIO	BCLK	BCLK	BCLK	BCLK
BS#	BS#	BS#	AS#	AS#	Connect to V <sub>SS</sub>	Connect to IO V <sub>DD</sub>
RD/WR#	RD/WR#	RD/WR#	R/W#	R/W#	RD1#	Connect to IO V <sub>DD</sub>
RD#	RD#	RD#	Connect to IO V <sub>DD</sub>	SIZ1	RD0#	RD#
WE0#	WE0#	WE0#	Connect to IO V <sub>DD</sub>	SIZ0	WE0#	WE#
WAIT#	WAIT#	RDY#	DTACK#	DSACK1#	WAIT#	WAIT#
RESET#	RESET#	RESET#	RESET#	RESET#	RESET#	RESET#

## 6 Technical Description

### 6.1 Embedded Memory Support

The SED1375 contains 80K bytes of embedded, 16-bit, SRAM used for the display buffer and a 32 byte internal register set.

Since the SED1375 does not distinguish between memory and register accesses, both the 80K byte display buffer and the 32 byte register set must be memory mapped into the host's memory space.

When using the SDU1375B0C board on an ISA bus system, the board can be configured to map the SED1375 to one of two memory blocks.

The SRAM start address is determined by a DIP switch setting. See Table 2-1: "Configuration DIP Switch Settings," on page 8.

1. When switch S1-5 is in the closed position, the SED1375 is mapped into segments 0C0000h and 0D0000h.

This memory space is in the first 1M byte of ISA bus memory and should be used if these segments are not taken up by other devices such as network adapters, SCSI cards, or other peripherals.

#### Note

Since VGA and VGA compatible video adapters use address 0C8000, these cards cannot be used while using the SDU1375B0C board at this memory address. A monochrome display adapter, a terminal, or a non-VGA compatible display adapter must be used.

2. When switch S1-5 is in the open position, the SED1375 is mapped into the upper megabyte of ISA bus memory, starting address of F00000h. To use this memory on an ISA bus system, the system BIOS has to be configured to set a memory 'hole' starting at this address. Some systems allow the user to configure the size of this hole and the starting address of where it begins while others just allow a 1M byte hole at the top of the 16M byte memory space. This memory hole is configured by entering the system CMOS Setup Utility. This memory space should be used if segments 0Dh and 0Eh are being used by other devices or if a VGA display adapter is needed.

Starting at the SRAM start address, the board design decodes a 128K byte segment accommodating both the 80K byte display buffer and the SED1375 internal register set. The SED1375 registers are mapped into the upper 32 bytes of the 128K byte segment (1FFE0h to 1FFFFh).

When using the SDU1375B0C board on a non-ISA bus system, system or external decode logic must map the SED1375 into an appropriate memory space.

## 6.2 ISA Bus Support

The SDU1375B0C board has been designed to directly support the 16-bit ISA bus environment and can be used in conjunction with either a VGA or a monochrome display adapter card.

There are 4 configuration inputs associated with the Host Interface (CNF[2:0] and BS#). Refer to Table 2-3: “Jumper Settings,” on page 9 and Table 5-1: “Host Bus Interface Pin Mapping,” on page 13 for complete details.

### 6.2.1 Display Adapter Card Support

When using the SDU1375B0C in conjunction with another primary Display Adapter (VGA or Monochrome) the following applies:

#### VGA Display Adapter

All VGA display adapters can be used with the SDU1375B0C board if the SED1375 is mapped to the upper 1M Byte of ISA bus memory, address F00000-F1FFFF. If the SED1375 is mapped to the address range 0C0000-0D0000, then no VGA or VGA compatible display adapters can be used with the SDU1375B0C board. See Embedded Memory Support on page 14.

#### Monochrome Display Adapter

The SDU1375B0C board can be used with monochrome display adapters at both memory addresses.

### 6.2.2 Expanded Memory Manager Support

If a memory manager is being used for system memory, the address range selected for the SRAM start address must be excluded from use or memory conflicts will arise.

## 6.3 Non-ISA Bus Support

The SDU1375B0C board is specifically designed to support the standard 16-bit ISA bus. However, the SED1375 directly supports many other host bus interfaces. Header strips H1 and H2 are provided and contain all the necessary IO pins to interface to these host buses. See CPU/Bus Interface Connector Pinouts on page 11; Table 2-1: “Configuration DIP Switch Settings,” on page 8; and Table 2-3: “Jumper Settings,” on page 9 for details.

When using the header strips to provide the bus interface observe the following:

- All signals on the ISA bus card edge must be isolated from the ISA bus (do not plug the card into a computer). Power must be provided through the headers.
- U7, a PLD of type 22V10-15, is used to provide the SED1375 CS# (pin 74) and other decoding logic signals for ISA bus mode. For non-ISA applications, this functionality must be provided externally. Remove the PAL from its socket to eliminate conflicts driving SED1375 control signals. Refer to Table 5-1: “Host Bus Interface Pin Mapping” for connection details.

**Note**

When using a 3.3V host bus interface, IO  $V_{DD}$  must be set to 3.3V by setting jumper (JP1) to the 2-3 position. Refer to Table 2-3: “Jumper Settings,” on page 9.

## 6.4 Decoding Logic

All the required decode logic is provided through a PLD of type 22V10-15 (U7, socketed). This PAL contains the following equations.

```
!CS      = (Address >= ^hC0000) & (Address <= ^hDFFFF) & !ADDR & REFRESH & ENAB
          # (Address1 >= ^hF00000) & (Address1 <= ^hF1FFFF) & ADDR & REFRESH & ENAB;

!MEMCS16 = (Address1 >= ^h0C0000) & (Address1 <= ^h0DFFFF) & !ADDR & !CS
          # (Address1 >= ^hF00000) & (Address1 <= ^hF1FFFF) & ADDR & !CS;

!WE0     = (!CS & !ADDR & !SMEMW) # (!CS & ADDR & !MEMW);

!RD      = (!CS & !ADDR & !SMEMR) # (!CS & ADDR & !MEMR);
```

**Note**

ADDR = Switch S1-5 (see Table 2-1: “Configuration DIP Switch Settings,” on page 8).

## 6.5 Clock Input Support

The input clock (CLKI) frequency can be up to 50MHz for the SED1375 if the internal clock divide-by-2 mode is set. If the clock divider is not used, the maximum CLKI frequency is 25MHz. There is no minimum input clock frequency.

A 25.0MHz oscillator (U2, socketed) is provided as the input clock source. However, depending on the LCD resolution, desired frame rate, and power consumption budget, a lower frequency clock may be required.

## 6.6 LCD Panel Voltage Setting

The SDU1375B0C board supports both 3.3V and 5V LCD panels through the LCD connector J5. The voltage level is selected by setting jumper J4 to the appropriate position. Refer to Table 2-3: “Jumper Settings,” on page 9 for setting this jumper.

Although not necessary for signal buffering, buffers have been implemented in the board design to provide flexibility in handling 3 and 5 volt panels.

## 6.7 Monochrome LCD Panel Support

The SED1375 directly supports 4 and 8-bit, dual and single, monochrome passive LCD panels. All necessary signals are provided on the 40-pin ribbon cable header J5. The interface signals on the cable are alternated with grounds to reduce crosstalk and noise.

Refer to Table 3-1: “LCD Signal Connector (J5) Pinout,” on page 10 for specific connection information.

## 6.8 Color Passive LCD Panel Support

The SED1375 directly supports 4 and 8-bit, dual and single, color passive LCD panels. All the necessary signals are provided on the 40-pin ribbon cable header J5. The interface signals on the cable are alternated with grounds to reduce crosstalk and noise.

Refer to Table 3-1: “LCD Signal Connector (J5) Pinout,” on page 10 for specific connection information.

## 6.9 Color TFT/D-TFD LCD Panel Support

The SED1375 directly supports 9 and 12-bit active matrix color TFT/D-TFD panels. All the necessary signals can also be found on the 40-pin LCD connector J5. The interface signals on the cable are alternated with grounds to reduce crosstalk and noise.

Refer to Table 3-1: “LCD Signal Connector (J5) Pinout,” on page 10 for connection information.

## 6.10 Power Save Modes

The SED1375 supports hardware and software power save modes. These modes are controlled by the utility 1375PWR. The hardware power save mode needs to be enabled by 1375PWR and then activated by DIP switch S1-6. See Table 2-1: “Configuration DIP Switch Settings,” on page 8 for details on setting this switch.

## 6.11 Adjustable LCD Panel Negative Power Supply

For those LCD panels requiring a negative power supply to provide between -23V and -14V ( $I_{out}=25mA$ ) a power supply has been provided as an integral part of this design. The VLCD power supply can be adjusted by R21 to give an output voltage from -23V to -14V, and is enabled and disabled by the active high SED1375 control signal LCDPWR, inverted externally.

Determine the panel's specific power requirements and set the potentiometer accordingly before connecting the panel.

## 6.12 Adjustable LCD Panel Positive Power Supply

For those LCD panels requiring a positive power supply to provide between +23V and +40V ( $I_{out}=45mA$ ) a power supply has been provided as an integral part of this design. The VDDH power supply can be adjusted by R15 to provide an output voltage from +23V to +40V and is enabled and disabled by the active high SED1375 control signal LCDPWR, inverted externally.

Determine the panel's specific power requirements and set the potentiometer accordingly before connecting the panel.

## 6.13 CPU/Bus Interface Header Strips

All of the CPU/Bus interface pins of the SED1375 are connected to the header strips H1 and H2 for easy interface to a CPU/Bus other than ISA.

Refer to Table 4-1: "CPU/BUS Connector (H1) Pinout," on page 11 and Table 4-2: "CPU/BUS Connector (H2) Pinout," on page 12 for specific settings.

### Note

These headers only provide the CPU/bus interface signals from the SED1375. When another host bus interface is selected by CNF[3:0] and BS#, appropriate external decoding logic MUST be used to access the SED1375. Refer to Table 5-1: "Host Bus Interface Pin Mapping," on page 13 for connection details.



## 7 Parts List

Item #	Qty/board	Designation	Part Value	Description
1	15	C1-C11, C15-17,C24	0.1uF, 20%, 50V	0805 ceramic capacitor
2	3	C12-14	10uF, 10%, 25V	Tantalum capacitor size D
3	2	C18, C22	47uF, 10%, 16V	Tantalum capacitor size D
4	3	C19-C21	4.7uF, 10%, 50V	Tantalum capacitor size D
5	1	C23	56uF, 20%, 63V	Electrolytic, radial, low ESR
6	2	H1,H2	CON34A Header	0.1" 17x2 header, PTH
7	5	JP1-JP4, JP6	HEADER 3	0.1" 1x3 header, PTH
8	1	J1	AT CON-A	ISA Bus gold fingers
9	1	J2	AT CON-B	ISA Bus gold fingers
10	1	J3	AT CON-C	ISA Bus gold fingers
11	1	J4	AT CON-D	ISA Bus gold fingers
12	1	J5	CON40A	Shrouded header 2x20, PTH, center key
13	1	L1	1μH	MCI-1812 inductor
14	2	L3, L4	Ferrite bead	Philips BDS3/3/8.9-4S2
15	1	Q1	2N3906	PNP signal transistor, SOT23
16	1	Q2	2N3904	NPN signal transistor, SOT23
17	6	R1-R6	15K, 5%	0805 resistor
18	9	R7-R13, R17, R18	10K, 5%	0805 resistor
19	1	R14	475K, 1%	0805 resistor
20	1	R15	200K Pot.	200K Trim POT Spectrol 63S204T607 (or equivalent)
21	1	R16	14K, 1%	0805 resistor
22	3	R19, R20, R22	100K, 5%	0805 resistor
23	1	R21	100K Pot.	100K Trim POT Spectrol 63S104T607 (or equivalent)
24	1	S1	SW DIP-6	6 position DIP switch
25	1	U1	SED1375F0A	QFP14-80, 80 pin, SMT
26	1	U2	25.0 MHz oscillator	FOX 25MHz oscillator or equiv., 14 pin DIP socketed
27	3	U3-U5	74AHC244	SO-22, TI74AHC244
28	1	U6	LT1117CM-3.3	Linear Technology 5V to 3.3V regulator, 800mA
29	1	U7	PLD22V10-15	PLD type 22V10-15, 20 Pin DIP, socketed
30	1	U8	74ALS125	SO-14, 74ALS125
31	1	U9	74HCT04	SO-14, 74HCT04
32	1	U10	RD-0412	Xentek RD-0412, positive PS
33	1	U11	EPN001	Xentek EPN001 negative PS

# 8 Schematic Diagrams

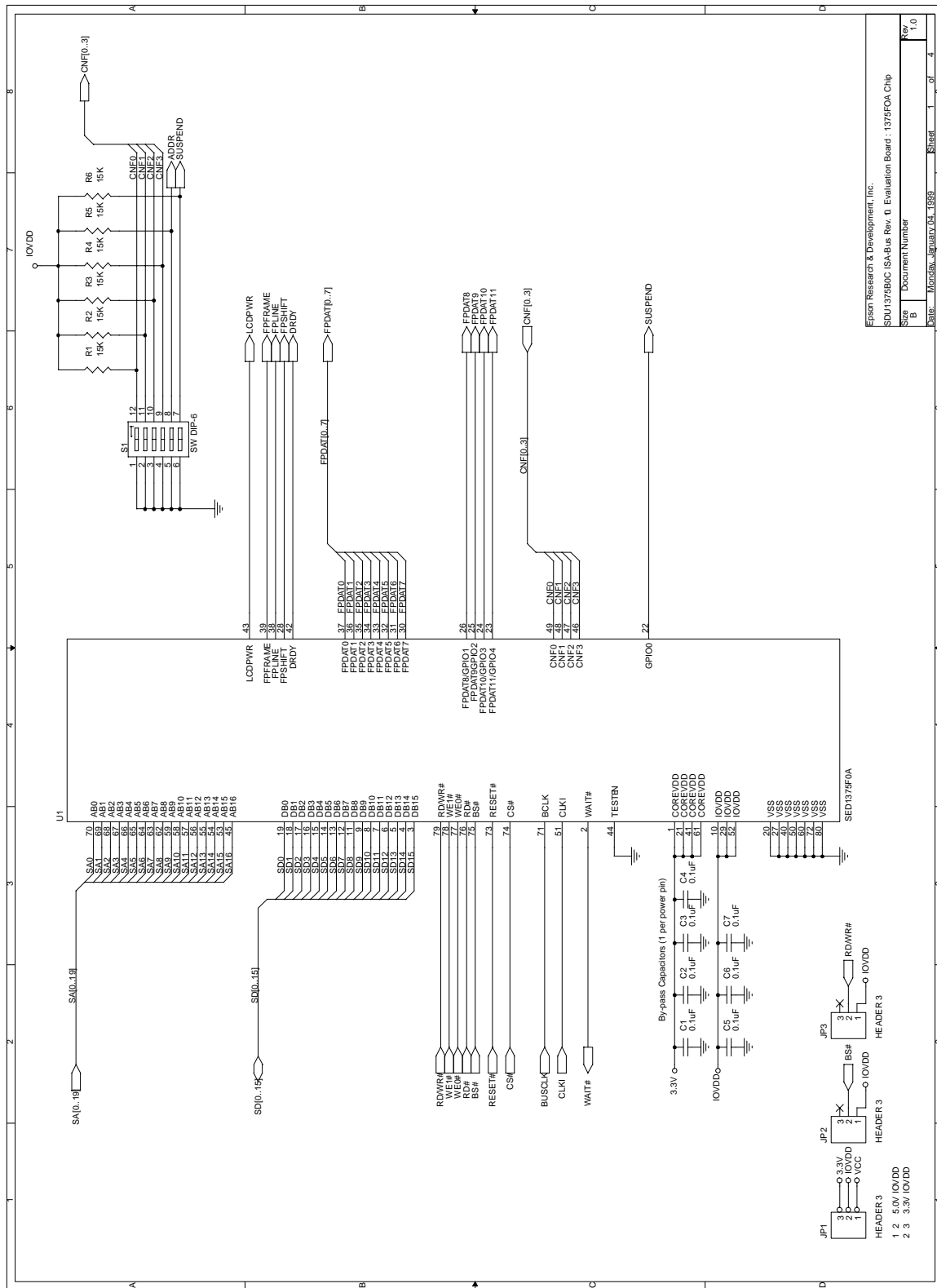
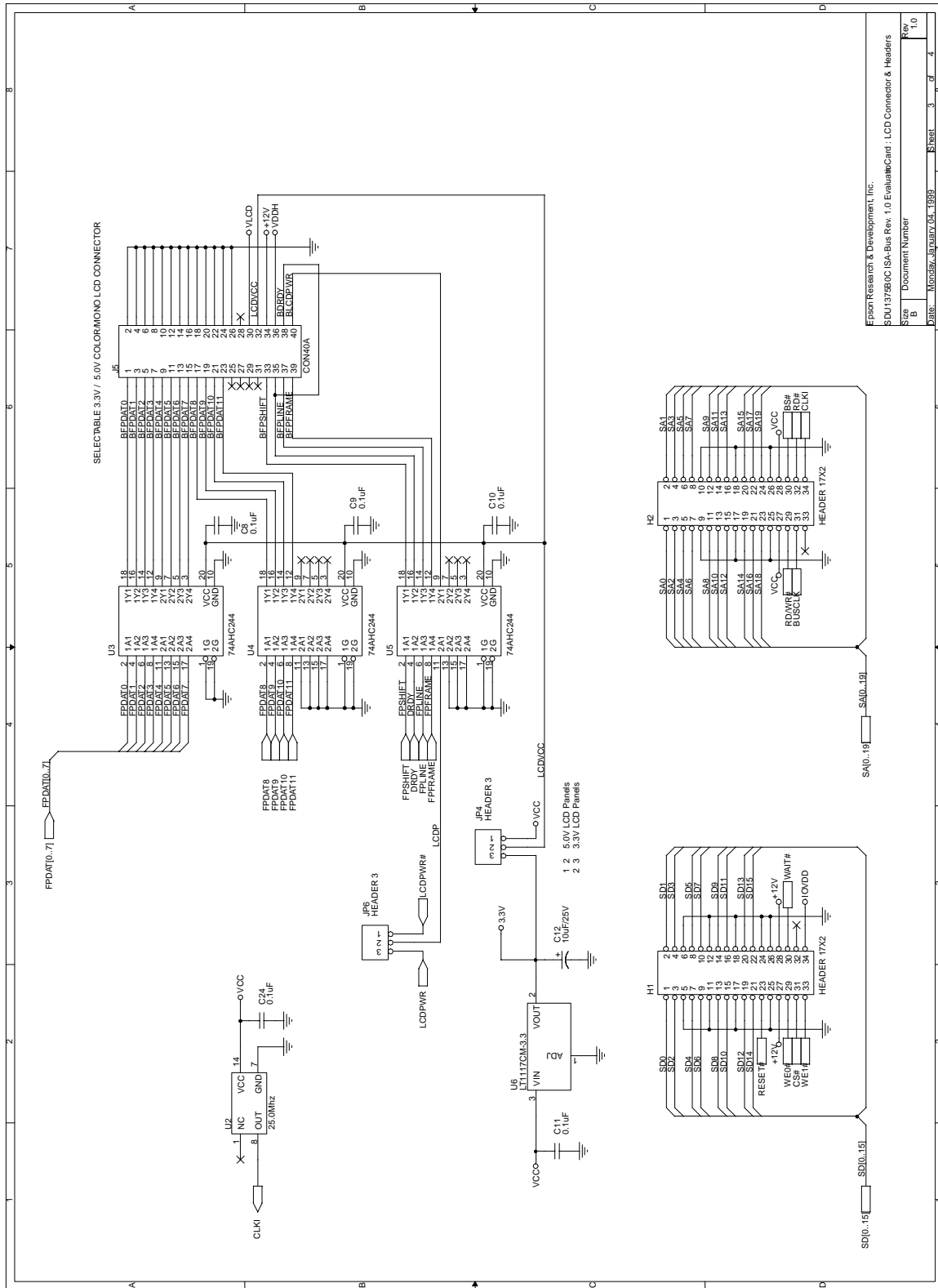

Figure 8-1: SED1375B0C Schematic Diagram (1 of 4)





Epson Research & Development, Inc.  
SDU1375B0C ISA-Bus Rev. 1.0 EvaluationCard : LCD Connector & Headers

Size	B	Document Number	
Rev	1.0	Date	Monday, July 25, 1999
Sheet	3	of	4

Figure 8-3: SED1375B0C Schematic Diagram (3 of 4)

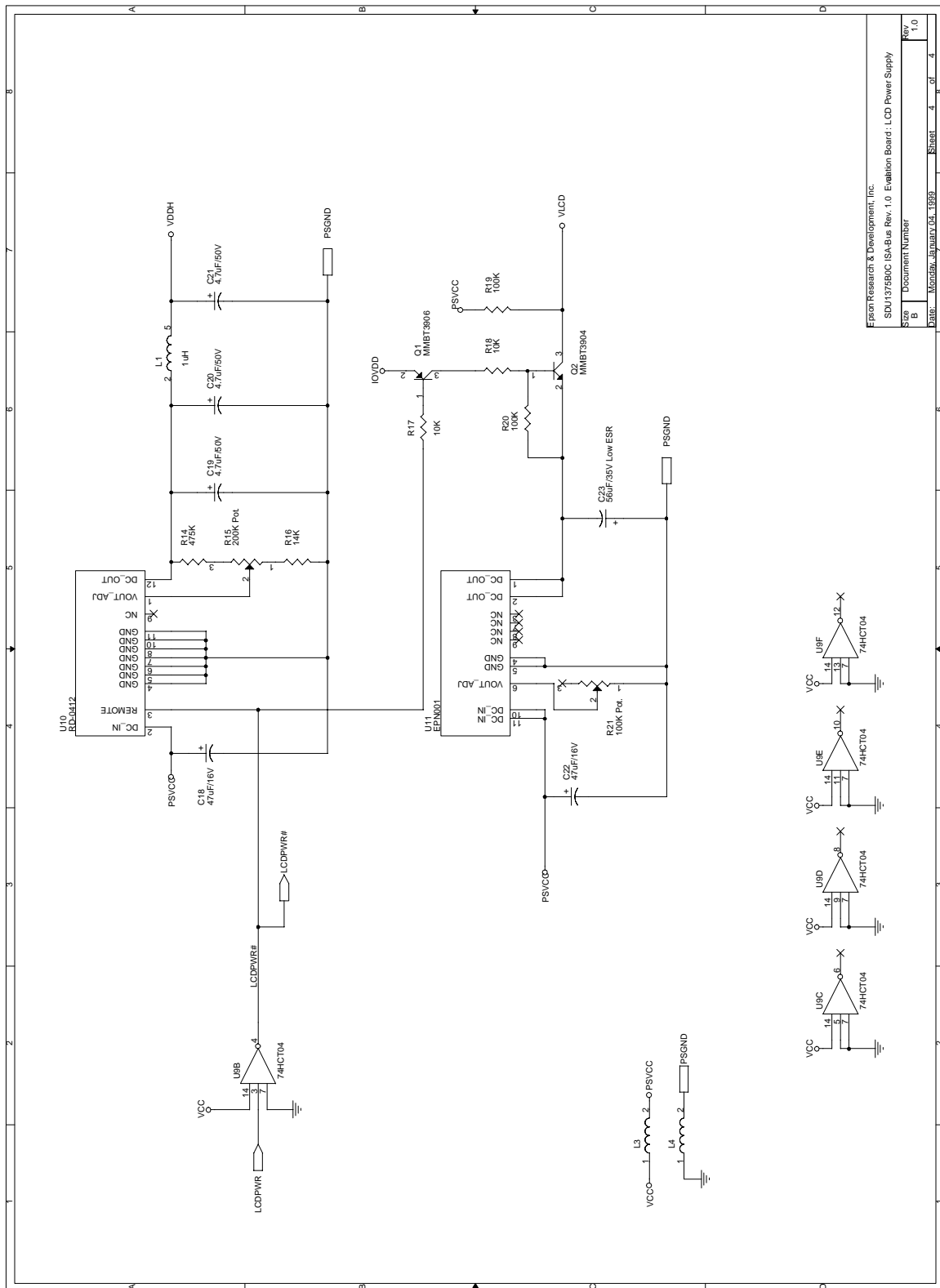

Epson Research & Development, Inc.	
SDU1375B0C ISA-Bus Rev. 1.0 Evaluation Board - LCD Power Supply	
Size	B
Document Number	
Rev	1.0
Date	Monday, July 04, 1999
Sheet	4 of 4

Figure 8-4: SED1375B0C Schematic Diagram (4 of 4)

**THIS PAGE LEFT BLANK**

# EPSON®



## SED1375 Embedded Memory LCD Controller

# Interfacing to the Toshiba MIPS TMPR3912 Microprocessor

Document Number: X27A-G-004-01

Copyright © 1999 Epson Research and Development, Inc. All Rights Reserved.

Information in this document is subject to change without notice. You may download and use this document, but only for your own use in evaluating Seiko Epson/EPSON products. You may not modify the document. Epson Research and Development, Inc. disclaims any representation that the contents of this document are accurate or current. The Programs/Technologies described in this document may contain material protected under U.S. and/or International Patent laws.

EPSON is a registered trademark of Seiko Epson Corporation. All other trademarks are the property of their respective owners.

---

**THIS PAGE LEFT BLANK**



# Table of Contents

<b>1</b>	<b>Introduction</b>	<b>7</b>
<b>2</b>	<b>Interfacing to the TMPR3912</b>	<b>8</b>
<b>3</b>	<b>SED1375 Host Bus Interface</b>	<b>9</b>
3.1	Host Bus Pin Connection	9
3.2	Generic #1 Interface Mode	10
3.3	Generic #2 Interface Mode	11
<b>4</b>	<b>Direct Connection to the Toshiba TMPR3912</b>	<b>12</b>
4.1	General Description	12
4.2	Memory Mapping and Aliasing	13
4.3	SED1375 Configuration	13
<b>5</b>	<b>Using the ITE IT8368E PC Card Buffer</b>	<b>14</b>
5.1	Hardware Description	14
5.2	IT8368E Configuration	16
5.3	Memory Mapping and Aliasing	16
5.4	SED1375 Configuration	17
<b>6</b>	<b>Software</b>	<b>18</b>
<b>7</b>	<b>Technical Support</b>	<b>19</b>
7.1	EPSON LCD Controllers (SED1375)	19
7.2	Toshiba MIPS TMPR3912 Processor	19
7.3	ITE IT8368E	19

**THIS PAGE LEFT BLANK**

---

## List of Tables

Table 3-1: Host Bus Interface Pin Mapping . . . . .	9
Table 4-1: SED1375 Configuration for Direct Connection . . . . .	13
Table 5-1: TMPR3912 to PC Card Slots Address Mapping With and Without the IT8368E. . . . .	16
Table 5-2: SED1375 Configuration Using the IT8368E. . . . .	17

## List of Figures

Figure 4-1: SED1375 to TMPR3912 Direct Connection . . . . .	12
Figure 5-1: SED1375 to TMPR3912 Connection Using an IT8368E . . . . .	15

**THIS PAGE LEFT BLANK**

---

# 1 Introduction

This application note describes the hardware required to interface the SED1375 Embedded Memory LCD Controller and the Toshiba MIPS TMPR3912 Processor. The pairing of these two devices results in an embedded system offering impressive display capability with very low power consumption.

The designs described in this document are presented only as examples of how such interfaces might be implemented. This application note will be updated as appropriate. Please check the Epson Electronics America website at <http://www.eea.epson.com> for the latest revision of this document before beginning any development.

We appreciate your comments on our documentation. Please contact us via email at [techpubs@erd.epson.com](mailto:techpubs@erd.epson.com).

## 2 Interfacing to the Tmpr3912

The Toshiba MIPS Tmpr3912 processor supports up to two PC Card (PCMCIA) slots. It is through this host bus interface that the SED1375 connects to the Tmpr3912 processor.

The SED1375 can be successfully interfaced using one of two configurations:

- Direct connection to Tmpr3912.
- System design using one ITE IT8368E PC Card/GPIO buffer chip.

## 3 SED1375 Host Bus Interface

This section is a summary of the host bus interface modes available on the SED1375 that would be used to interface to the TMPR3912.

The SED1375 implements a 16-bit interface to the host microprocessor which may operate in one of several modes compatible with most of the popular embedded microprocessor families. The interface modes used for the TMPR3912 are:

- Generic #1 (Chip Select, plus individual Read Enable/Write Enable for each byte).
- Generic #2 (External Chip Select, shared Read/Write Enable for high byte, individual Read/Write Enable for low byte).

### 3.1 Host Bus Pin Connection

The following table shows the functions of each host bus interface signal.

*Table 3-1: Host Bus Interface Pin Mapping*

SED1375 Pin Names	Generic #1	Generic #2
AB[15:1]	A[15:1]	A[15:1]
AB0	A0	A0
DB[15:0]	D[15:0]	D[15:0]
WE1#	WE1#	BHE#
CS#	External Decode	External Decode
BCLK	BCLK	BCLK
BS#	connect to $V_{SS}$	connect to IO $V_{DD}$
RD/WR#	RD1#	connect to IO $V_{DD}$
RD#	RD0#	RD#
WE0#	WE0#	WE#
WAIT#	WAIT#	WAIT#
RESET#	RESET#	RESET#

For configuration details, refer to the *SED1375 Hardware Functional Specification*, document number X27A-A-001-xx.

## 3.2 Generic #1 Interface Mode

Generic #1 interface mode is the most general and least processor-specific interface mode on the SED1375. The Generic # 1 interface mode was chosen for this interface due to the simplicity of its timing.

The interface requires the following signals:

- BUSCLK is a clock input which is required by the SED1375 host interface. It is separate from the input clock (CLKI) and is typically driven by the host CPU system clock.
- The address inputs AB0 through AB16, and the data bus DB0 through DB15, connect directly to the CPU address and data bus, respectively. On 32-bit big endian architectures such as the Power PC, the data bus would connect to the high-order data lines; on little endian hosts, or 16-bit big endian hosts, they would connect to the low-order data lines. The hardware engineer must ensure that CNF3 selects the proper endian mode upon reset.
- Chip Select (CS#) is driven by decoding the high-order address lines to select the proper register and memory address space.
- WE0# and WE1# are write enables for the low-order and high-order bytes, respectively, to be driven low when the host CPU is writing data to the SED1375. These signals must be generated by external hardware based on the control outputs from the host CPU.
- RD# and RD/WR# are read enables for the low-order and high-order bytes, respectively, to be driven low when the host CPU is reading data from the SED1375. These signals must be generated by external hardware based on the control outputs from the host CPU.
- WAIT# is a signal output from the SED1375 that indicates the host CPU must wait until data is ready (read cycle) or accepted (write cycle) on the host bus. Since host CPU accesses to the SED1375 may occur asynchronously to the display update, it is possible that contention may occur in accessing the SED1375 internal registers and/or refresh memory. The WAIT# line resolves these contentions by forcing the host to wait until the resource arbitration is complete. This signal is active low and may need to be inverted if the host CPU wait state signal is active high.
- The Bus Status (BS#) signal is not used in the bus interface for Generic #1 mode. However, BS# is used to configure the SED1375 for Generic #1 mode and should be tied low (connected to GND).



### 3.3 Generic #2 Interface Mode

Generic #2 interface mode is a general and non-processor-specific interface mode on the SED1375. The Generic # 2 interface mode was chosen for this interface due to the simplicity of its timing and compatibility with the TMPR3912 control signals.

The interface requires the following signals:

- BUSCLK is a clock input which synchronizes transfers between the host CPU and the SED1375. It is separate from the input clock (CLKI) and is typically driven by the host CPU system clock.
- The address inputs AB0 through AB16, and the data bus DB0 through DB15, connect directly to the CPU address and data bus, respectively. On 32-bit big endian architectures such as the Power PC, the data bus would connect to the high-order data lines; on little endian hosts, or 16-bit big endian hosts, they would connect to the low-order data lines. The hardware engineer must ensure that CNF3 selects the proper endian mode upon reset.
- Chip Select (CS#) is driven by decoding the high-order address lines to select the proper register and memory address space.
- WE1# is the high byte enable for both read and write cycles for the SED1375, to be driven low when the host CPU accesses the SED1375.
- WE0# is the write enable for the SED1375, to be driven low when the host CPU is reading data from the SED1375.
- RD# is the read enable for the SED1375, to be driven low when the host CPU is reading data from the SED1375.
- WAIT# is a signal which is output from the SED1375 to the host CPU that indicates when data is ready (read cycle) or accepted (write cycle) on the host bus. Since host CPU accesses to the SED1375 may occur asynchronously to the display update, it is possible that contention may occur in accessing the 1375 internal registers and/or refresh memory. The WAIT# line resolves these contentions by forcing the host to wait until the resource arbitration is complete. This signal is active low and may need to be inverted if the host CPU wait state signal is active high.
- The Bus Status (BS#) and Read/Write (RD/WR#) signals are not used in the bus interface for Generic #2 mode. However, BS# is used to configure the SED1375 for Generic #2 mode and should be tied high (connected to IO  $V_{DD}$ ). RD/WR# should also be tied high.

## 4 Direct Connection to the Toshiba TMPR3912

### 4.1 General Description

In this example implementation, the SED1375 occupies the TMPR3912 PC Card slot #1.

The SED1375 is easily interfaced to the TMPR3912 with minimal additional logic. The address bus of the TMPR3912 PC Card interface is multiplexed and must be demultiplexed using an advanced CMOS latch (e.g., 74AHC373). The direct connection approach makes use of the SED1375 in its “Generic Interface #2” configuration.

The following diagram demonstrates a typical implementation of the interface.

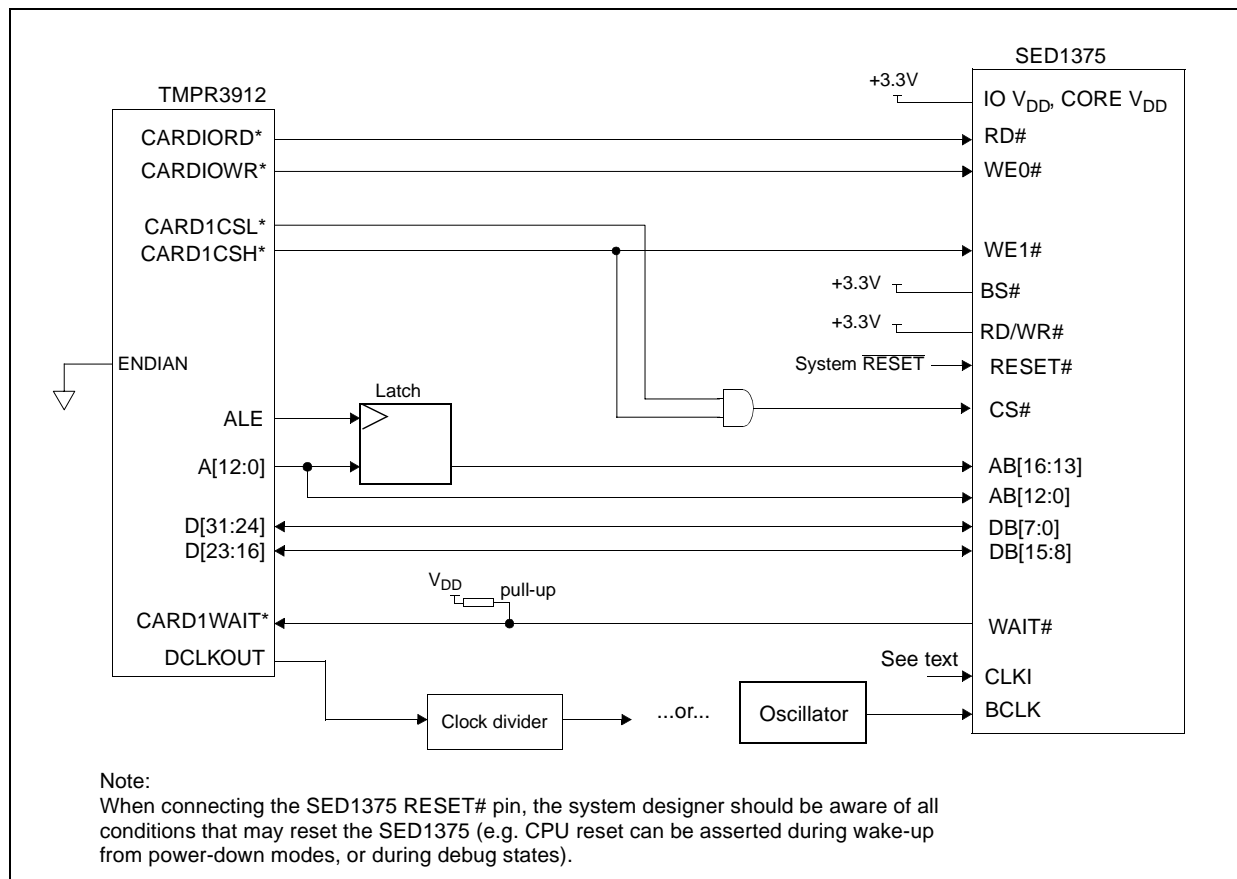

Figure 4-1: SED1375 to TMPR3912 Direct Connection

#### Note

See Section 3.1 on page 9 and Section 3.3 on page 11 for Generic #2 pin descriptions.

The “Generic #2” host interface control signals of the SED1375 are asynchronous with respect to the SED1375 bus clock. This gives the system designer full flexibility to choose the appropriate source (or sources) for CLKI and BCLK. The choice of whether both clocks should be the same, and whether to use DCLKOUT (divided) as clock source, should be based on the desired:

- pixel and frame rates.
- power budget.
- part count.
- maximum SED1375 clock frequencies.

The SED1375 also has internal clock dividers providing additional flexibility.

## 4.2 Memory Mapping and Aliasing

In this example implementation the TMPR3912 control signal CARDREG\* is ignored; therefore the SED1375 takes up the entire PC Card slot 1.

The SED1375 requires an addressing space of 128K bytes. The on-chip display memory occupies the range 0 through 13FFFh. The registers occupy the range 1FFE0h through 1FFFFh. The TMPR3912 demultiplexed address lines A17 and above are ignored, thus the SED1375 is aliased 512 times at 128K byte intervals over the 64M byte PC Card slot #1 memory space.

### Note

If aliasing is undesirable, additional decoding circuitry must be added.

## 4.3 SED1375 Configuration

The SED1375 is configured at power up by latching the state of the CNF[3:0] pins. Pin BS# also plays a role in host bus interface configuration. For details on configuration, refer to the *SED1375 Hardware Functional Specification*, document number X27A-A-001-xx.

The table below shows those configuration settings relevant to the direct connection approach.

Table 4-1: SED1375 Configuration for Direct Connection

SED1375 Configuration Pin	Value hard wired on this pin is used to configure:	
	1 (IO V <sub>DD</sub> )	0 (V <sub>SS</sub> )
BS#	Generic #2	Generic #1
CNF3	Big Endian	Little Endian
CNF[2:0]	111: Generic #1 or #2	

= configuration for Toshiba TMPR3912 host bus interface

## 5 Using the ITE IT8368E PC Card Buffer

If the system designer uses the ITE IT8368E PC Card and multiple-function I/O buffer, the SED1375 can be interfaced so that it “shares” a PC Card slot. The SED1375 is mapped to a rarely-used 16M byte portion of the PC Card slot buffered by the IT8368E, making the SED1375 virtually transparent to PC Card devices that use the same slot.

### 5.1 Hardware Description

The ITE8368E has been specially designed to support EPSON LCD controllers and provides eleven Multi-Function IO pins (MFIO). Configuration registers may be used to allow these MFIO pins to provide the control signals required to implement the SED1375 CPU interface.

The TMPR3912 processor only provides addresses A[12:0], therefore devices requiring more address space must use an external device to latch A[25:13]. The IT8368E’s MFIO pins can be configured to provide this latched address.

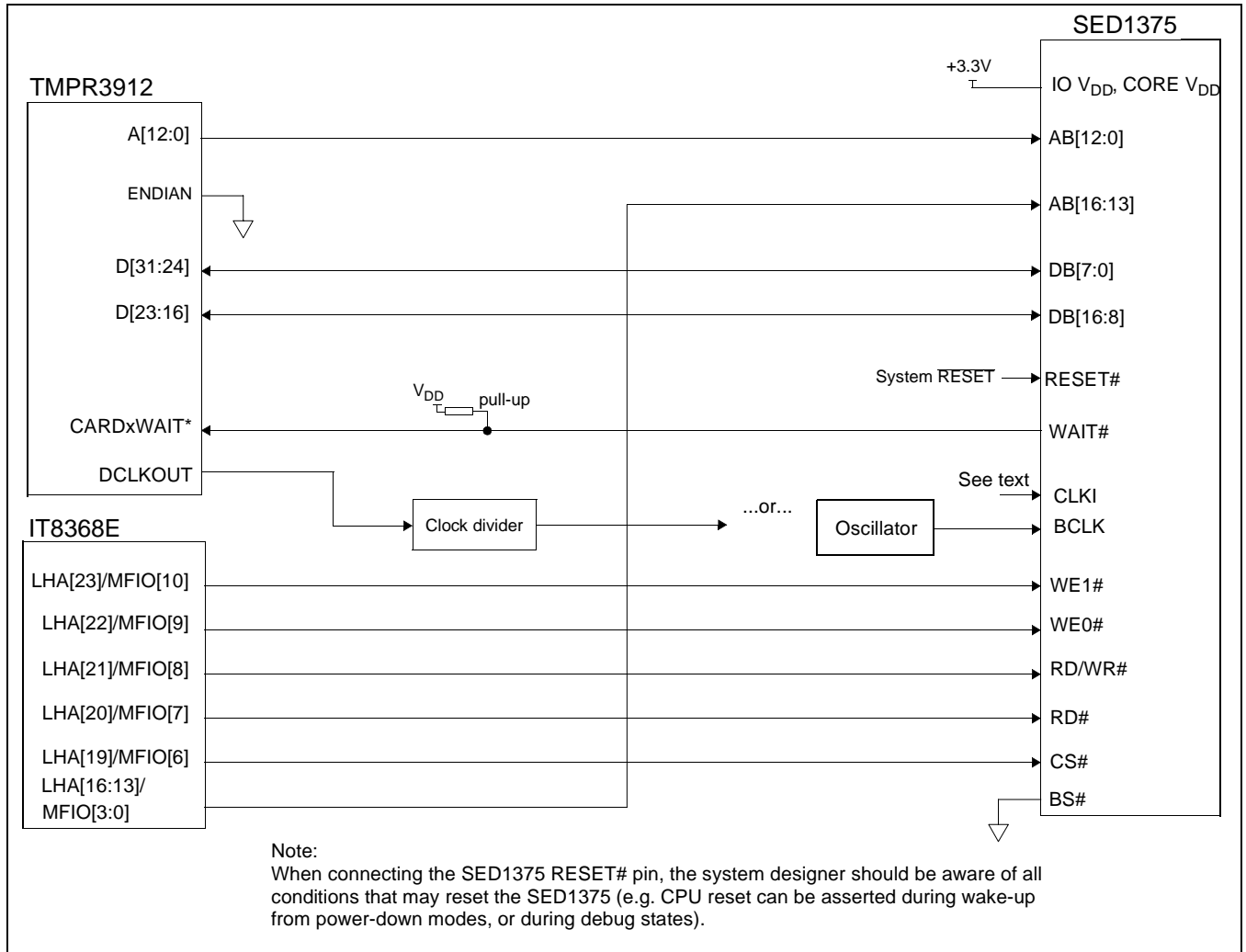

Figure 5-1: SED1375 to TMPR3912 Connection Using an IT8368E

**Note**

See Section 3.1 on page 9 and Section 3.2 on page 10 for Generic #1 pin descriptions.

The “Generic #1” host interface control signals of the SED1375 are asynchronous with respect to the SED1375 bus clock. This gives the system designer full flexibility to choose the appropriate source (or sources) for CLKI and BCLK. The choice of whether both clocks should be the same, and whether to use DCLKOUT (divided) as clock source, should be based on pixel and frame rates, power budget, part count and maximum SED1375 respective clock frequencies. Also, internal SED1375 clock dividers provide additional flexibility.

## 5.2 IT8368E Configuration

The IT8368E provides eleven multi-function IO pins (MFIO). The IT8368E must have both “Fix Attribute/IO” and “VGA” modes on. When both these modes are enabled, the MFIO pins provide control signals needed by the SED1375 host bus interface, and a 16M byte portion of the system PC Card attribute and IO space is allocated to address the SED1375. When accessing the SED1375 the associated card-side signals are disabled in order to avoid any conflicts.

For mapping details, refer to section 3.3: “Memory Mapping and Aliasing.” For connection details see Figure 5-1: “*SED1375 to TMPR3912 Connection Using an IT8368E*,” on page 15. For further information on the IT8368E, refer to the *IT8368E PC Card/GPIO Buffer Chip Specification*.

### Note

When a second IT8368E is used, that circuit should not be set in VGA mode.

## 5.3 Memory Mapping and Aliasing

When the TMPR3912 accesses the PC Card slots *without* the ITE IT8368E, its system memory is mapped as in Table 5-1: *TMPR3912 to PC Card Slots Address Mapping With and Without the IT8368E*.

### Note

Bit CARD1IOEN or CARD2IOEN, depending on which card slot is used, must to be set to 0 in the TMPR3912 Memory Configuration Register 3.

When the TMPR3912 accesses the PC Card slots buffered through the ITE IT8368E, bits CARD1IOEN and CARD2IOEN are ignored and the attribute/IO space of the TMPR3912 is divided into Attribute, I/O and SED1375 access. Details of the Attribute/IO address reallocation by the IT8368E are found in Table 5-1: *TMPR3912 to PC Card Slots Address Mapping With and Without the IT8368E*.

Table 5-1: *TMPR3912 to PC Card Slots Address Mapping With and Without the IT8368E*

PC Card Slot #	TMPR3912 Address	Size	Using the ITE IT8368E	Direct Connection, CARDnIOEN=0	Direct Connection, CARDnIOEN=1
1	0800 0000h	16M byte	Card 1 IO	SED1375 (aliased 512 times at 128K byte intervals)	Card 1 IO
	0900 0000h	16M byte	SED1375 (aliased 128 times at 128K byte intervals)		
	0A00 0000h	32M byte	Card 1 Attribute		
	6400 0000h	64M byte	Card 1 Memory		
2	0C00 0000h	16M byte	Card 2 IO	SED1375 (aliased 512 times at 128K byte intervals)	Card 2 IO
	0D00 0000h	16M byte	SED1375 (aliased 128 times at 128K byte intervals)		
	0E00 0000h	32M byte	Card 2 Attribute		
	6800 0000h	64M byte	Card 2 Memory		

## 5.4 SED1375 Configuration

The SED1375 is configured at power up by latching the state of the CNF[3:0] pins. Pin BS# also plays a role in host bus interface configuration. For details on configuration, refer to the *SED1375 Hardware Functional Specification*, document number X26A-A-001-xx.

The table below shows those configuration settings relevant to this specific interface.

Table 5-2: SED1375 Configuration Using the IT8368E

SED1375 Configuration Pin	Value hard wired on this pin is used to configure:	
	1 (IO V <sub>DD</sub> )	0 (V <sub>SS</sub> )
BS#	Generic #2	Generic #1
CNF3	Big Endian	Little Endian
CNF[2:0]	111: Generic #1 or #2	

= configuration for connection using ITE IT8368E

## 6 Software

Test utilities and Windows® CE v2.0 display drivers are available for the SED1375. Full source code is available for both the test utilities and the drivers.

The test utilities are configurable for different panel types using a program called 1357CFG, or by directly modifying the source. The Windows CE v2.0 display drivers can be customized by the OEM for different panel types, resolutions and color depths only by modifying the source.

The SED1375 test utilities and Windows CE v2.0 display drivers are available from your sales support contact or [www.eea.epson.com](http://www.eea.epson.com).



## 7 Technical Support

### 7.1 EPSON LCD Controllers (SED1375)

#### Japan

Seiko Epson Corporation  
Electronic Devices Marketing Division  
421-8, Hino, Hino-shi  
Tokyo 191-8501, Japan  
Tel: 042-587-5812  
Fax: 042-587-5564

#### North America

Epson Electronics America, Inc.  
150 River Oaks Parkway  
San Jose, CA 95134, USA  
Tel: (408) 922-0200  
Fax: (408) 922-0238  
<http://www.eea.epson.com>

#### Taiwan, R.O.C.

Epson Taiwan Technology  
& Trading Ltd.  
10F, No. 287  
Nanking East Road  
Sec. 3, Taipei, Taiwan, R.O.C.  
Tel: 02-2717-7360  
Fax: 02-2712-9164

#### Europe

Epson Europe Electronics GmbH  
Riesstrasse 15  
80992 Munich, Germany  
Tel: 089-14005-0  
Fax: 089-14005-110

#### Hong Kong

Epson Hong Kong Ltd.  
20/F., Harbour Centre  
25 Harbour Road  
Wanchai, Hong Kong  
Tel: 2585-4600  
Fax: 2827-4346

#### Singapore

Epson Singapore Pte., Ltd.  
No. 1  
Temasek Avenue #36-00  
Millenia Tower  
Singapore, 039192  
Tel: 337-7911  
Fax: 334-2716

### 7.2 Toshiba MIPS Tmpr3912 Processor

<http://www.toshiba.com/taec/nonflash/indexproducts.html>

### 7.3 ITE IT8368E

#### Integrated Technology Express, Inc.

Sales & Marketing Division  
2710 Walsh Avenue  
Santa Clara, CA 95051, USA  
Tel: (408) 980-8168  
Fax: (408) 980-9232  
<http://www.iteusa.com>

**THIS PAGE LEFT BLANK**



## **SED1375 Embedded Memory LCD Controller**

# **SED1375 Power Consumption**

**Document Number: X27A-G-006-01**

Copyright © 1999 Epson Research and Development, Inc. All Rights Reserved.

Information in this document is subject to change without notice. You may download and use this document, but only for your own use in evaluating Seiko Epson/EPSON products. You may not modify the document. Epson Research and Development, Inc. disclaims any representation that the contents of this document are accurate or current. The Programs/Technologies described in this document may contain material protected under U.S. and/or International Patent laws.

EPSON is a registered trademark of Seiko Epson Corporation. All other Trademarks are the property of their respective owners

---

**THIS PAGE LEFT BLANK**

# 1 SED1375 Power Consumption

SED1375 power consumption is affected by many system design variables.

- Input clock frequency (CLKI): the CLKI frequency and the internal clock divide register determine the operating clock (CLK) frequency of the SED1375. The higher CLK is, the higher the frame rate, performance, and power consumption.
- CPU interface: the SED1375 current consumption depends on the BUSCLK frequency, data width, number of toggling pins, and other factors – the higher the BUSCLK, the higher the CPU performance and power consumption.
- $V_{DD}$  voltage levels (Core and IO): the voltage level of the Core and IO sections in the SED1375 affects power consumption – the higher the voltage, the higher the consumption.
- Display mode: the resolution, panel type, and color depth affect power consumption. The higher the resolution/color depth and number of LCD panel signals, the higher the power consumption.

## Note

If the High Performance option is turned on, the power consumption increases to that of 8 bit-per-pixel mode for all color depths.

There are two power save modes in the SED1375: Software and Hardware Power Save. The power consumption of these modes is affected by various system design variables.

- CPU bus state during Power Save: the state of the CPU bus signals during Power Save has a substantial effect on power consumption. An inactive bus (e.g. BUSCLK = low, Addr = low etc.) reduces overall system power consumption.
- CLKI state during Power Save: disabling the CLKI during Power Save has substantial power savings.

## 1.1 Conditions

Table 1-1: “SED1375 Total Power Consumption” below gives an example of a specific environment and its effects on power consumption.

Table 1-1: SED1375 Total Power Consumption

Test Condition <i>Core V<sub>DD</sub> = 3.3V, IO V<sub>DD</sub> = 3.3V BUSCLK = 8.33MHz</i>		Gray Shades / Colors	Power Consumption				
			Active			Power Save Mode	
			Core	IO	Total	Software	Hardware
1	Input Clock = 6MHz LCD Panel = 320x240 4-bit Single Monochrome	Black-and-White	4.29mW	0.52mW	4.81mW	1.44mW <sup>1</sup>	1.21mW <sup>2</sup>
		4 Gray Shades	4.99mW	0.76mW	5.75mW		
		16 Gray Shades	6.13mW	0.75mW	6.88mW		
2	Input Clock = 6MHz LCD Panel = 320x240 4-bit Single Color	2 Colors	4.64mW	0.73mW	5.37mW	1.44mW <sup>1</sup>	1.22mW <sup>2</sup>
		4 Colors	5.30mW	1.51mW	6.81mW		
		16 Colors	6.58mW	1.57mW	8.15mW		
		256 Colors	8.65mW	1.52mW	10.16mW		
3	Input Clock = 25MHz LCD Panel = 640x480 8-bit Single Monochrome	Black-and-White	13.97mW	1.10mW	15.07mW	2.53mW <sup>1</sup>	2.32mW <sup>2</sup>
		4 Gray Shades	16.75mW	2.08mW	18.83mW		
4	Input Clock = 25MHz LCD Panel = 640x480 8-bit Single Color	2 Colors	15.53mW	2.64mW	18.17mW	2.53mW <sup>1</sup>	2.32mW <sup>2</sup>
		4 Colors	18.30mW	7.16mW	25.47mW		
5	Input Clock = 25MHz LCD Panel = 640x480 8-bit Dual Monochrome	Black-and-White 4 Grey Shades	13.84mW 20.38mW	1.08mW 2.07mW	14.93mW 22.45mW	2.53mW <sup>1</sup>	2.32mW <sup>2</sup>
6	Input Clock = 25MHz LCD Panel = 640x480 8-bit Dual Color	2 Colors 4 Colors	15.82mW 23.31mW	2.62mW 7.01mW	18.44mW 30.32mW	2.53mW <sup>1</sup>	2.32mW <sup>2</sup>
7	Input Clock = 25MHz LCD Panel = 640x480 9-bit TFT	2 Colors 4 Colors	11.42mW 19.74mW	7.40mW 20.96mW	18.82mW 40.70mW	2.53mW <sup>1</sup>	2.32mW <sup>2</sup>

### Note

1. Conditions for Software Power Save:
  - CPU interface active (signals toggling)
  - CLKI active
2. Conditions for Hardware Power Save:
  - CPU interface inactive (high impedance)
  - CLKI active

## 2 Summary

The system design variables in Section 1, “SED1375 Power Consumption” and in Table 1-1: “SED1375 Total Power Consumption” show that SED1375 power consumption depends on the specific implementation. Active Mode power consumption depends on the desired CPU performance and LCD frame-rate, whereas Power Save Mode consumption depends on the CPU Interface and Input Clock state.

In a typical design environment, the SED1375 can be configured to be an extremely power-efficient LCD Controller with high performance and flexibility.

**THIS PAGE LEFT BLANK**



# EPSON®



## SED1375 Embedded Memory LCD Controller

# Interfacing to the Motorola MC68328 'Dragonball' Microprocessor

Document Number: X27A-G-007-01

Copyright © 1999 Epson Research and Development, Inc. All Rights Reserved.

Information in this document is subject to change without notice. You may download and use this document, but only for your own use in evaluating Seiko Epson/EPSON products. You may not modify the document. Epson Research and Development, Inc. disclaims any representation that the contents of this document are accurate or current. The Programs/Technologies described in this document may contain material protected under U.S. and/or International Patent laws.

EPSON is a registered trademark of Seiko Epson Corporation. All Trademarks are the property of their respective owners.

---

**THIS PAGE LEFT BLANK**

# Table of Contents

<b>1</b>	<b>Introduction</b>	<b>7</b>
<b>2</b>	<b>Interfacing to the MC68328</b>	<b>8</b>
2.1	The MC68328 System Bus	8
2.2	Chip-Select Module	8
<b>3</b>	<b>SED1375 Host Bus Interface</b>	<b>9</b>
3.1	Host Bus Pin Connection	9
3.2	Generic #1 Interface Mode	10
3.3	MC68K #1 Interface Mode	11
<b>4</b>	<b>MC68328 To SED1375 Interface</b>	<b>12</b>
4.1	Hardware Description	12
4.1.1	Using The MC68K #1 Host Bus Interface	12
4.1.2	Using The Generic #1 Host Bus Interface	13
4.2	SED1375 Hardware Configuration	14
4.3	MC68328 Chip Select Configuration	14
<b>5</b>	<b>Software</b>	<b>15</b>
<b>6</b>	<b>References</b>	<b>16</b>
6.1	Documents	16
6.2	Document Sources	16
<b>7</b>	<b>Technical Support</b>	<b>17</b>
7.1	EPSON LCD Controllers (SED1375)	17
7.2	Motorola MC68328 Processor	17

**THIS PAGE LEFT BLANK**

---

## List of Tables

Table 3-1: Host Bus Interface Pin Mapping . . . . .	9
Table 4-1: Summary of Power-On/Reset Options . . . . .	14
Table 4-2: Host Bus Interface Selection . . . . .	14

## List of Figures

Figure 4-1: Typical Implementation of MC68328 to SED1375 Interface - MC68K #1 . . . . .	12
Figure 4-2: Typical Implementation of MC68328 to SED1375 Interface - Generic #1 . . . . .	13

**THIS PAGE LEFT BLANK**

---

# 1 Introduction

This application note describes the hardware required to interface the SED1375 Embedded Memory LCD Controller and the Motorola MC68328 “Dragonball” Microprocessor. By implementing an embedded display refresh buffer, the SED1375 can reduce system power consumption, improve image quality, and increase system performance as compared to the Dragonball’s on-chip LCD controller.

The designs described in this document are presented only as examples of how such interfaces might be implemented. This application note will be updated as appropriate. Please check the Epson Electronics America website at <http://www.eea.epson.com> for the latest revision of this document before beginning any development.

We appreciate your comments on our documentation. Please contact us via email at [techpubs@erd.epson.com](mailto:techpubs@erd.epson.com).

## 2 Interfacing to the MC68328

### 2.1 The MC68328 System Bus

The MC68328 is an integrated controller for handheld products, based upon the MC68EC000 microprocessor core. It implements a 16-bit data bus and a 32-bit address bus. The bus interface consists of all the standard MC68000 bus interface signals, plus some new signals intended to simplify the task of interfacing to typical memory and peripheral devices.

The MC68000 bus control signals are well documented in Motorola's user manuals, and will not be described here. A brief summary of the new signals appears below:

- Output Enable (OE#) is asserted when a read cycle is in process; it is intended to connect to the output enable control of a typical static RAM, EPROM, or Flash EPROM device.
- Upper Write Enable and Lower Write Enable (UWE#/LWE#) are asserted during memory write cycles for the upper and lower bytes of the 16-bit data bus; they may be directly connected to the write enable inputs of a typical memory device.

The SED1375 implements the MC68000 bus interface using its MC68K #1 mode, so this mode may be used to connect the MC68328 directly to the SED1375 with no glue logic. However, several of the MC68000 bus control signals are multiplexed with IO and interrupt signals on the MC68328, and in many applications it may be desirable to make these pins available for these alternate functions. This requirement may be accommodated through the use of the Generic #1 interface mode on the SED1375.

### 2.2 Chip-Select Module

The MC68328 can generate up to 16 chip select outputs, organized into four groups "A" through "D".

Each chip select group has a common base address register and address mask register, to set the base address and block size of the entire group. In addition, each chip select within a group has its own address compare and address mask register, to activate the chip select for a subset of the group's address block. Finally, each chip select may be individually programmed to control an 8 or 16-bit device, and each may be individually programmed to generate from 0 through 6 wait states internally, or allow the memory or peripheral device to terminate the cycle externally through use of the standard MC68000 DTACK# signal.

Groups A and B can have a minimum block size of 64K bytes, so these are typically used to control memory devices. Chip select A0 is active immediately after reset, so it is typically used to control a boot EPROM device. Groups C and D have a minimum block size of 4K bytes, so they are well-suited to controlling peripheral devices. Chip select D3 is associated with the MC68328 on-chip PCMCIA control logic.



## 3 SED1375 Host Bus Interface

This section is a summary of the host bus interface modes available on the SED1375 that may be used to interface to the MC68328.

The SED1375 implements a 16-bit interface to the host microprocessor which may operate in one of several modes compatible with most of the popular embedded microprocessor families. The two interface modes that may be used for the MC68328 are:

- Motorola MC68K #1 (using Upper Data Strobe/Lower Data Strobe).
- Generic #1 (Chip Select, plus individual Read Enable/Write Enable for each byte).

### 3.1 Host Bus Pin Connection

The following table shows the functions of each host bus interface signal.

*Table 3-1: Host Bus Interface Pin Mapping*

SED1375 Pin Names	MC68K #1	Generic #1
AB[15:1]	A[15:1]	A[15:1]
AB0	LDS#	A0
DB[15:0]	D[15:0]	D[15:0]
WE1#	UDS#	WE1#
CS#	External Decode	External Decode
BCLK	CLK	BCLK
BS#	AS#	connect to V <sub>SS</sub>
RD/WR#	R/W#	RD1#
RD#	connect to IO V <sub>DD</sub>	RD0#
WE0#	connect to IO V <sub>DD</sub>	WE0#
WAIT#	DTACK#	WAIT#
RESET#	RESET#	RESET#

For details on configuration, refer to the *SED1375 Hardware Functional Specification*, document number X27A-A-001-xx.

## 3.2 Generic #1 Interface Mode

Generic #1 interface mode is the most general and least processor-specific interface mode on the SED1375. The Generic # 1 interface mode was chosen for this interface due to the simplicity of its timing.

The interface requires the following signals:

- BUSCLK is a clock input which is required by the SED1375 host interface. It is separate from the input clock (CLKI) and is typically driven by the host CPU system clock.
- The address inputs AB0 through AB16, and the data bus DB0 through DB15, connect directly to the CPU address and data bus, respectively. On 32-bit big endian architectures such as the Power PC, the data bus would connect to the high-order data lines; on little endian hosts, or 16-bit big endian hosts, they would connect to the low-order data lines. The hardware engineer must ensure that CNF3 selects the proper endian mode upon reset.
- Chip Select (CS#) is driven by decoding the high-order address lines to select the proper register and memory address space.
- WE0# and WE1# are write enables for the low-order and high-order bytes, respectively, to be driven low when the host CPU is writing data to the SED1375. These signals must be generated by external hardware based on the control outputs from the host CPU.
- RD# and RD/WR# are read enables for the low-order and high-order bytes, respectively, to be driven low when the host CPU is reading data from the SED1375. These signals must be generated by external hardware based on the control outputs from the host CPU.
- WAIT# is a signal output from the SED1375 that indicates the host CPU must wait until data is ready (read cycle) or accepted (write cycle) on the host bus. Since host CPU accesses to the SED1375 may occur asynchronously to the display update, it is possible that contention may occur in accessing the SED1375 internal registers and/or refresh memory. The WAIT# line resolves these contentions by forcing the host to wait until the resource arbitration is complete. This signal is active low and may need to be inverted if the host CPU wait state signal is active high.
- The Bus Status (BS#) signal is not used in the bus interface for Generic #1 mode. However, BS# is used to configure the SED1375 for Generic #1 mode and should be tied low (connected to GND).

### 3.3 MC68K #1 Interface Mode

The MC68K #1 Interface Mode can be used to interface to the MC68328 microprocessor if the previously mentioned, multiplexed, bus signals will not be used for other purposes.

The interface requires the following signals:

- BUSCLK is a clock input which synchronizes transfers between the host CPU and the SED1375. It is separate from the input clock (CLKI) and is typically driven by the host CPU system clock.
- The address inputs AB1 through AB16, and the data bus DB0 through DB15, connect directly to the CPU address and data bus, respectively. On 32-bit big endian architectures such as the Power PC, the data bus would connect to the high-order data lines; on little endian hosts, or 16-bit big endian hosts, they would connect to the low-order data lines. The hardware engineer must ensure that CNF3 selects the proper endian mode upon reset.
- Chip Select (CS#) is driven by decoding the high-order address lines to select the proper register and memory address space.
- A0 and WE1# are the enables for the low-order and high-order bytes, respectively, to be driven low when the host CPU is reading or writing data to the SED1375.
- RD/WR# is the read/write signal that is driven low when the CPU writes to the SED1375 and is driven high when the CPU is doing a read from the SED1375.
- WAIT# is a signal which is output from the SED1375 to the host CPU that indicates when data is ready (read cycle) or accepted (write cycle) on the host bus. Since host CPU accesses to the SED1375 may occur asynchronously to the display update, it is possible that contention may occur in accessing the SED1375 internal registers and/or refresh memory. The WAIT# line resolves these contentions by forcing the host to wait until the resource arbitration is complete.
- The Bus Status (BS#) signal indicates that the address on the address bus is valid.
- The WE0# and RD# signals is not used in the bus interface for MC68K #1 and must be tied high (tied to IO  $V_{DD}$ ).

## 4 MC68328 To SED1375 Interface

### 4.1 Hardware Description

The interface between the MC68328 and the SED1375 can be implemented using either the MC68K #1 or Generic #1 host bus interface of the SED1375.

#### 4.1.1 Using The MC68K #1 Host Bus Interface

The MC68328 multiplexes dual functions on some of its bus control pins (specifically UDS#, LDS#, and DTACK#). In implementations where all of these pins are available for use as bus control pins, then the SED1375 interface is a straightforward implementation of the “MC68K #1” host bus interface. For further information on this host bus interface, refer to the *SED1375 Hardware Functional Specification*, document number X27A-A-001-xx.

The following diagram shows a typical implementation of the MC68328 to SED1375 using the MC68K #1 host bus interface.

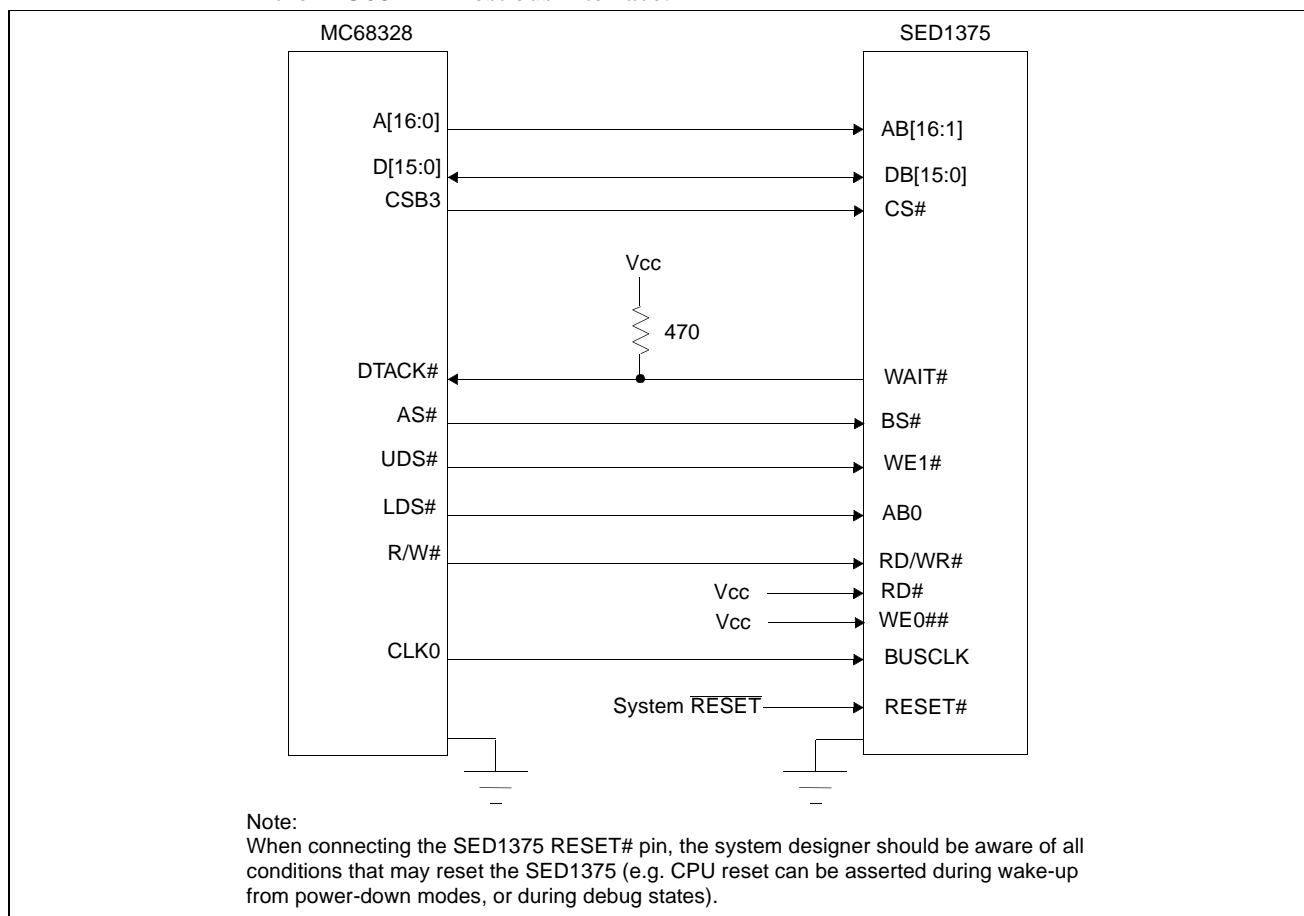

Figure 4-1: Typical Implementation of MC68328 to SED1375 Interface - MC68K #1

### 4.1.2 Using The Generic #1 Host Bus Interface

If UDS# and/or LDS# are required for their alternate IO functions, then the MC68328 to SED1375 interface may be implemented using the SED1375 Generic #1 host bus interface. Note that in either case, the DTACK# signal must be made available for the SED1375, since it inserts a variable number of wait states depending upon CPU/LCD synchronization and the LCD panel display mode. WAIT# must be inverted (using an inverter enabled by CS#) to make it an active high signal and thus compatible with the MC68328 architecture. A single resistor is used to speed up the rise time of the WAIT# (DTACK#) signal when terminating the bus cycle.

The following diagram shows a typical implementation of the MC68328 to SED1375 using the Generic #1 host bus interface.

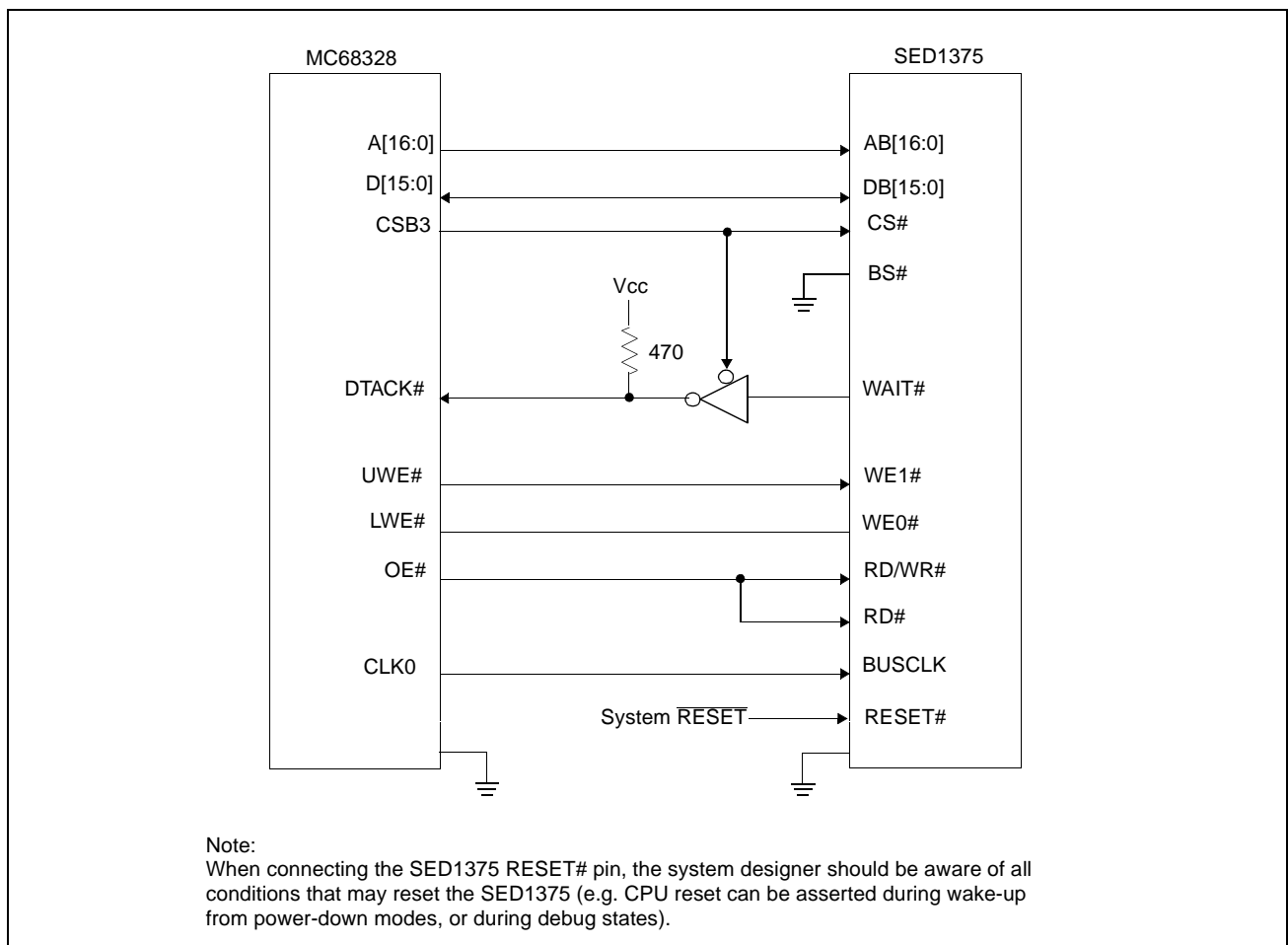

Figure 4-2: Typical Implementation of MC68328 to SED1375 Interface - Generic #1

## 4.2 SED1375 Hardware Configuration

The SED1375 uses CNF3 through CNF0 and BS# to allow selection of the bus mode and other configuration data on the rising edge of RESET#. Refer to the *SED1375 Hardware Functional Specification*, document number X27A-A-001-xx for details.

The tables below show those configuration settings important to the MC68K #1 and Generic #1 host bus interfaces.

Table 4-1: Summary of Power-On/Reset Options

SED1375 Pin Name	value on this pin at the rising edge of RESET# is used to configure: (1/0)	
	0	1
CNF0	See Table 4-2: "Host Bus Interface Selection"	
CNF1		
CNF2		
CNF3	Little Endian	Big Endian

 = configuration for MC68328 support

Table 4-2: Host Bus Interface Selection

CNF2	CNF1	CNF0	BS#	Host Bus Interface
0	0	0	X	SH-4 interface
0	0	1	X	SH-3 interface
0	1	0	X	reserved
0	1	1	X	MC68K #1, 16-bit
1	0	0	X	reserved
1	0	1	X	MC68K #2, 16-bit
1	1	0	0	reserved
1	1	0	1	reserved
1	1	1	0	Generic #1, 16-bit
1	1	1	1	Generic #2, 16-bit

 = configuration for MC68328 using Generic #1 host bus interface

 = configuration for MC68328 using MC68K #1 host bus interface

## 4.3 MC68328 Chip Select Configuration

The SED1375 requires a 128K byte address space for the display buffer and its internal registers. To accommodate this block size, it is preferable (but not required) to use one of the chip selects from groups A or B. Virtually any chip select other than CSA0 or CSD3 would be suitable for the SED1375 interface.

In the example interface, chip select CSB3 is used to control the SED1375. A 128K byte address space is used with the SED1375 control registers mapped into the top 32 bytes of the 128K byte block and the 80K bytes of display buffer mapped to the starting address of the block. The chip select should have its RO (Read Only) bit set to 0, and the WAIT field (Wait states) should be set to 111b to allow the SED1375 to terminate bus cycles externally.

---

## 5 Software

Test utilities and Windows® CE v2.0 display drivers are available for the SED1375. Full source code is available for both the test utilities and the drivers.

The test utilities are configurable for different panel types using a program called 1375CFG, or by directly modifying the source. The Windows CE v2.0 display drivers can be customized by the OEM for different panel types, resolutions and color depths only by modifying the source.

The SED1375 test utilities and Windows CE v2.0 display drivers are available from your sales support contact or on the internet at <http://www.eea.epson.com>.

## 6 References

### 6.1 Documents

- Motorola Inc., *MC68328 DragonBall® Integrated Microprocessor User's Manual*, Motorola Publication no. MC68328UM/AD; available on the Internet at <http://www.mot.com/SPS/WIRELESS/products/MC68328.html>.
- Epson Research and Development, Inc., *SED1375 Hardware Functional Specification*; Document Number X27A-A-001-xx.
- Epson Research and Development, Inc., *SDU1375B0C Rev. 1.0 ISA Bus Evaluation Board User Manual*; Document Number X27A-G-005-xx.
- Epson Research and Development, Inc., *SED1375 Programming Notes and Examples*; Document Number X27A-G-002-xx.

### 6.2 Document Sources

- Motorola Inc.: Motorola Literature Distribution Center, (800) 441-2447.
- Motorola Website: <http://www.mot.com>.
- Epson Electronics America website: <http://www.eea.epson.com>.



## 7 Technical Support

### 7.1 EPSON LCD Controllers (SED1375)

#### Japan

Seiko Epson Corporation  
Electronic Devices Marketing Division  
421-8, Hino, Hino-shi  
Tokyo 191-8501, Japan  
Tel: 042-587-5812  
Fax: 042-587-5564  
<http://www.epson.co.jp>

#### North America

Epson Electronics America, Inc.  
150 River Oaks Parkway  
San Jose, CA 95134, USA  
Tel: (408) 922-0200  
Fax: (408) 922-0238  
<http://www.eea.epson.com>

#### Taiwan, R.O.C.

Epson Taiwan Technology  
& Trading Ltd.  
10F, No. 287  
Nanking East Road  
Sec. 3, Taipei, Taiwan, R.O.C.  
Tel: 02-2717-7360  
Fax: 02-2712-9164

#### Hong Kong

Epson Hong Kong Ltd.  
20/F., Harbour Centre  
25 Harbour Road  
Wanchai, Hong Kong  
Tel: 2585-4600  
Fax: 2827-4346

#### Europe

Epson Europe Electronics GmbH  
Riesstrasse 15  
80992 Munich, Germany  
Tel: 089-14005-0  
Fax: 089-14005-110

#### Singapore

Epson Singapore Pte., Ltd.  
No. 1  
Temasek Avenue #36-00  
Millenia Tower  
Singapore, 039192  
Tel: 337-7911  
Fax: 334-2716

### 7.2 Motorola MC68328 Processor

- Motorola Design Line, (800) 521-6274.
- Local Motorola sales office or authorized distributor.

**THIS PAGE LEFT BLANK**

# EPSON®



## SED1375 Embedded Memory LCD Controller

# Interfacing to the NEC VR4102/VR4111 Microprocessor

Document Number: X27A-G-008-01

Copyright © 1999 Epson Research and Development, Inc. All Rights Reserved.

Information in this document is subject to change without notice. You may download and use this document, but only for your own use in evaluating Seiko Epson/EPSON products. You may not modify the document. Epson Research and Development, Inc. disclaims any representation that the contents of this document are accurate or current. The Programs/Technologies described in this document may contain material protected under U.S. and/or International Patent laws.

EPSON is a registered trademark of Seiko Epson Corporation. All Trademarks are the property of their respective owners.

---

**THIS PAGE LEFT BLANK**

# Table of Contents

<b>1</b>	<b>Introduction</b>	<b>9</b>
<b>2</b>	<b>Interfacing to the NEC VR4102/VR4111</b>	<b>10</b>
2.1	The NEC VR4102/VR4111 System Bus	10
2.1.1	Overview	10
2.1.2	LCD Memory Access Cycles	11
<b>3</b>	<b>SED1375 Host Bus Interface</b>	<b>12</b>
3.1	Host Bus Pin Connection	12
3.2	Generic #2 Interface Mode	13
<b>4</b>	<b>VR4102/VR4111 to SED1375 Interface</b>	<b>14</b>
4.1	Hardware Description	14
4.2	SED1375 Hardware Configuration	15
4.3	NEC VR4102/VR4111 Configuration	16
<b>5</b>	<b>Software</b>	<b>17</b>
<b>6</b>	<b>References</b>	<b>18</b>
6.1	Documents	18
6.2	Document Sources	18
<b>7</b>	<b>Technical Support</b>	<b>19</b>
7.1	Epson LCD Controllers (SED1375)	19
7.2	NEC Electronics Inc.	19

**THIS PAGE LEFT BLANK**

---

## List of Tables

Table 3-1: Host Bus Interface Pin Mapping . . . . .	12
Table 4-1: Summary of Power-On/Reset Options . . . . .	15
Table 4-2: Host Bus Selection . . . . .	15

## List of Figures

Figure 2-1: NEC VR4102/VR4111 Read/Write Cycles . . . . .	11
Figure 4-1: Typical Implementation of VR4102/VR4111 to SED1375 Interface . . . . .	14

**THIS PAGE LEFT BLANK**



# 1 Introduction

This application note describes the hardware required to interface the SED1375 Embedded Memory LCD Controller and the NEC VR4102/VR4111 Microprocessor (*u*PD30102). The NEC VR4102/VR4111 Microprocessor is specifically designed to support an external LCD controller and the pairing of these two devices results in an embedded system offering impressive display capability with very low power consumption.

The designs described in this document are presented only as examples of how such interfaces might be implemented. This application note will be updated as appropriate. Please check the Epson Electronics America website at <http://www.eea.epson.com> for the latest revision of this document before beginning any development.

We appreciate your comments on our documentation. Please contact us via email at [techpubs@erd.epson.com](mailto:techpubs@erd.epson.com).

## 2 Interfacing to the NEC VR4102/VR4111

### 2.1 The NEC VR4102/VR4111 System Bus

The VR-Series family of microprocessors features a high-speed synchronous system bus typical of modern microprocessors. Designed with external LCD controller support and Windows CE-based embedded consumer applications in mind, the VR4102/VR4111 offers a highly integrated solution for portable systems. This section is an overview of the operation of the CPU bus to establish interface requirements.

#### 2.1.1 Overview

The NEC VR4102/VR4111 is designed around the RISC architecture developed by MIPS. This microprocessor is designed around the 66MHz VR4100 CPU core which supports 64-bit processing. The CPU communicates with the Bus Control Unit (BCU) with its internal SysAD bus. The BCU in turn communicates with external devices with its ADD and DAT buses that can be dynamically sized to 16 or 32-bit operation.

The NEC VR4102/VR4111 has direct support for an external LCD controller. Specific control signals are assigned for an external LCD controller that provide an easy interface to the CPU. A 16M byte block of memory is assigned for the LCD controller with its own chip select and ready signals available. Word or byte accesses are controlled by the system high byte signal, SHB#.

## 2.1.2 LCD Memory Access Cycles

Once an address in the LCD block of memory is placed on the external address bus, ADD[25:0], the LCD chip select, LCDCS#, is driven low. The read or write enable signals, RD# and WR#, are driven low for the appropriate cycle. LCDRDY is driven low by the SED1375 to insert wait states into the cycle. The high byte enable is driven low for 16-bit transfers and high for 8-bit transfers.

Figure 2-1: “NEC VR4102/VR4111 Read/Write Cycles,” on page 9 shows the read and write cycles to the LCD Controller Interface.

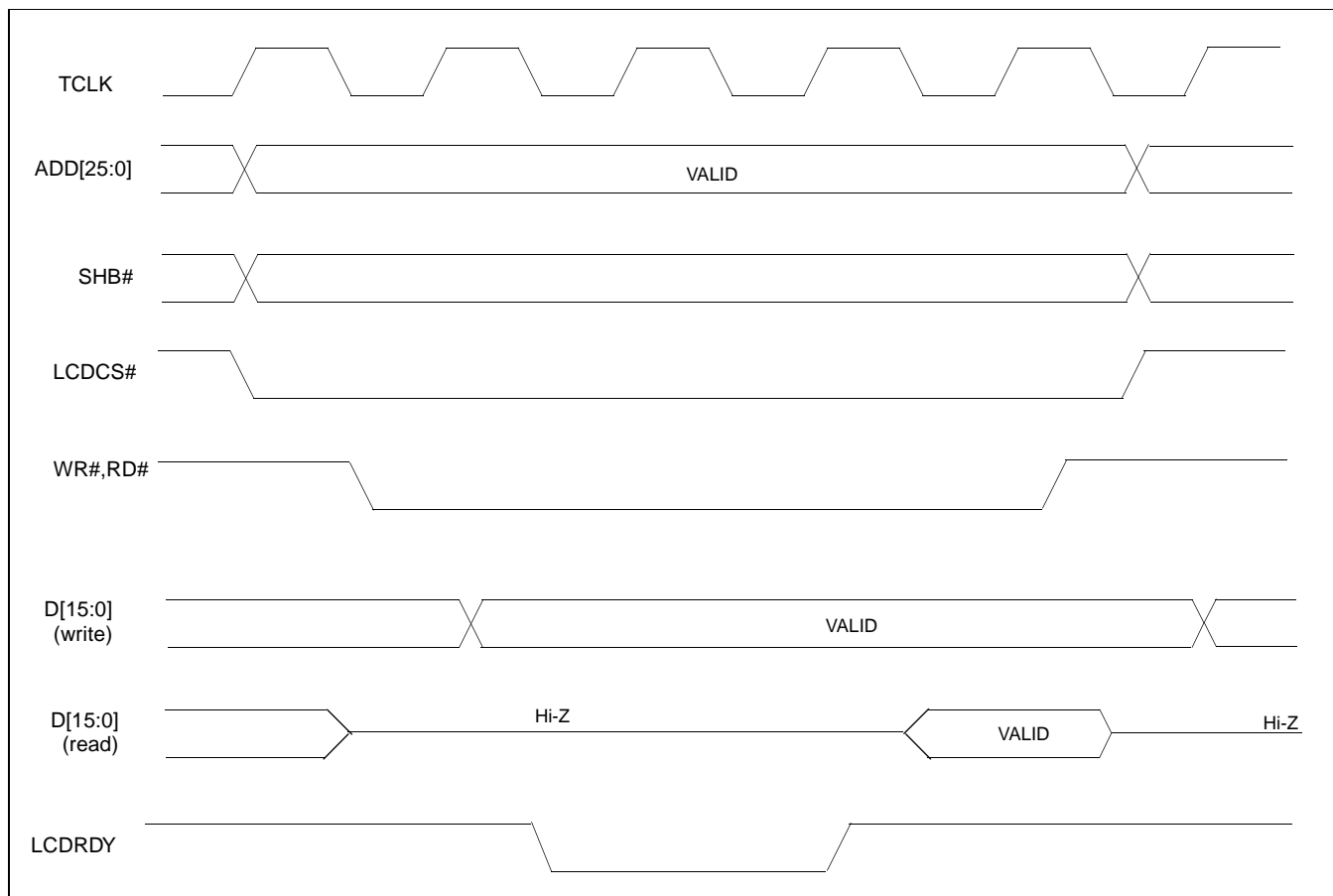

Figure 2-1: NEC VR4102/VR4111 Read/Write Cycles

## 3 SED1375 Host Bus Interface

This section is a summary of the host bus interface modes available on the SED1375 that would be used to interface to the VR4102/VR4111.

The SED1375 implements a 16-bit interface to the host microprocessor which may operate in one of several modes compatible with most of the popular embedded microprocessor families. The interface mode used for the VR4102/VR4111 is:

- Generic #2 (External Chip Select, shared Read/Write Enable for high byte, individual Read/Write Enable for low byte).

### 3.1 Host Bus Pin Connection

The following table shows the functions of each host bus interface signal.

*Table 3-1: Host Bus Interface Pin Mapping*

SED1375 Pin Names	Generic #2
AB[15:1]	A[15:1]
AB0	A0
DB[15:0]	D[15:0]
WE1#	BHE#
CS#	External Decode
BCLK	BCLK
BS#	connect to IO $V_{DD}$
RD/WR#	connect to IO $V_{DD}$
RD#	RD#
WE0#	WE#
WAIT#	WAIT#
RESET#	RESET#

For details on configuration, refer to the *SED1375 Hardware Functional Specification*, document number X27A-A-001-xx.

## 3.2 Generic #2 Interface Mode

Generic #2 interface mode is a general and non-processor-specific interface mode on the SED1375. The Generic # 2 interface mode was chosen for this interface due to the simplicity of its timing and compatibility with the VR4102/VR4111 control signals.

The interface requires the following signals:

- BUSCLK is a clock input which synchronizes transfers between the host CPU and the SED1375. It is separate from the input clock (CLKI) and is typically driven by the host CPU system clock.
- The address inputs AB0 through AB16, and the data bus DB0 through DB15, connect directly to the CPU address and data bus, respectively. On 32-bit big endian architectures such as the Power PC, the data bus would connect to the high-order data lines; on little endian hosts, or 16-bit big endian hosts, they would connect to the low-order data lines. The hardware engineer must ensure that CNF3 selects the proper endian mode upon reset.
- Chip Select (CS#) is driven by decoding the high-order address lines to select the proper register and memory address space.
- WE1# is the high byte enable for both read and write cycles.
- WE0# is the write enable for the SED1375, to be driven low when the host CPU is writing data to the SED1375.
- RD# is the read enable for the SED1375, to be driven low when the host CPU is reading data from the SED1375.
- WAIT# is a signal which is output from the SED1375 to the host CPU that indicates when data is ready (read cycle) or accepted (write cycle) on the host bus. Since host CPU accesses to the SED1375 may occur asynchronously to the display update, it is possible that contention may occur in accessing the 1375 internal registers and/or refresh memory. The WAIT# line resolves these contentions by forcing the host to wait until the resource arbitration is complete. This signal is active low and may need to be inverted if the host CPU wait state signal is active high.
- The Bus Status (BS#) and Read/Write (RD/WR#) signals are not used in the bus interface for Generic #2 mode. However, BS# is used to configure the SED1375 for Generic #2 mode and should be tied high (connected to IO  $V_{DD}$ ). RD/WR# should also be tied high.

## 4 VR4102/VR4111 to SED1375 Interface

### 4.1 Hardware Description

The NEC VR4102/VR4111 Microprocessor is specifically designed to support an external LCD controller by providing the internal address decoding and control signals necessary. By using the Generic # 2 interface, no glue logic is required to interface the SED1375 and the NEC VR4102/VR4111. A pull-up resistor is attached to WAIT# to speed up its rise time when terminating a cycle.

The following diagram shows a typical implementation of the VR4102/VR4111 to SED1375 interface.

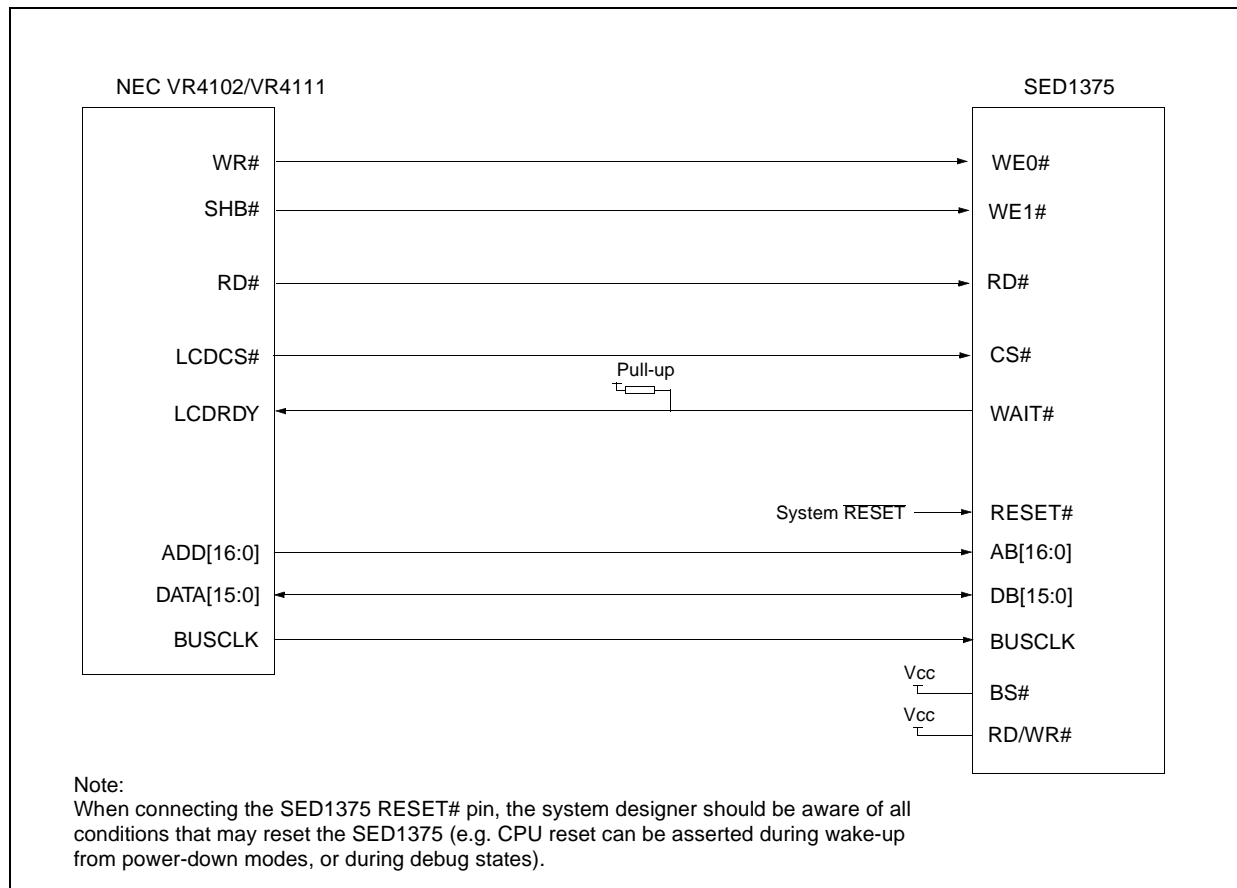

Figure 4-1: Typical Implementation of VR4102/VR4111 to SED1375 Interface

## 4.2 SED1375 Hardware Configuration

The SED1375 uses CNF3 through CNF0 and BS# to allow selection of the bus mode and other configuration data on the rising edge of RESET#. Refer to the *SED1375 Hardware Functional Specification*, document number X27A-A-001-xx for details.

The tables below show those configuration settings important to the Generic #2 host bus interface.

*Table 4-1: Summary of Power-On/Reset Options*

Signal	value on this pin at the rising edge of RESET# is used to configure: (0/1)	
	0	1
CNF0	See "Host Bus Selection" table below	See "Host Bus Selection" table below
CNF1		
CNF2		
CNF3	Little Endian	Big Endian

= configuration for NEC VR4102/VR4111 support

*Table 4-2: Host Bus Selection*

CNF2	CNF1	CNF0	BS#	Host Bus Interface
1	1	1	1	Generic #2, 16-bit

= configuration for NEC VR4102/VR4111 support

### 4.3 NEC VR4102/VR4111 Configuration

The NEC VR4102/VR4111 provides the internal address decoding necessary to map to an external LCD controller. Physical address 0A000000h to 0AFFFFFFh (16M bytes) is reserved for an external LCD controller.

The SED1375 supports up to 80K bytes of display buffer memory and 32 bytes for internal registers. Therefore, the SED1375 will be shadowed over the entire 16M byte memory range at 128K byte segments. The starting address of the display buffer is 0A000000h and register 0 of the SED1375 (REG[00h]) resides at 0A01FFE0h.

The NEC VR4102/VR4111 has a 16-bit internal register named BCUCNTREG2 located at address 0B000002h. It must be set to the value of 0001h to indicate that LCD controller accesses use a non-inverting data bus.

The 16-bit internal register named BCUCNTREG1, located at address 0B000000h, must have bit D[13] (ISA/LCD bit) set to 0 to reserve the 16M bytes space, 0A000000h to 0AFFFFFFh, for LCD use and not as ISA bus memory space.



---

## 5 Software

Test utilities and Windows® CE v2.0 display drivers are available for the SED1375. Full source code is available for both the test utilities and the drivers.

The test utilities are configurable for different panel types using a program called 1375CFG, or by directly modifying the source. The Windows CE v2.0 display drivers can be customized by the OEM for different panel types, resolutions and color depths only by modifying the source.

The SED1375 test utilities and Windows CE v2.0 display drivers are available from your sales support contact or on the internet at <http://www.eea.epson.com>.

## 6 References

### 6.1 Documents

- NEC VR4102/VR4111 64/32-bit Microprocessor Preliminary User's Manual.
- Epson Research and Development, Inc., *SED1375 Embedded Memory Color LCD Controller Hardware Functional Specification*; Document Number X27A-A-001-xx.
- Epson Research and Development, Inc., *SDU1375B0C Rev. 1.0 ISA Bus Evaluation Board User Manual*; Document Number X27A-G-005-xx.
- Epson Research and Development, Inc., *SED1375 Programming Notes and Examples*; Document Number X27A-G-002-xx.

### 6.2 Document Sources

- NEC website: <http://www.nec.com>.
- Epson Electronics America website: <http://www.eea.epson.com>

## 7 Technical Support

### 7.1 Epson LCD Controllers (SED1375)

#### Japan

Seiko Epson Corporation  
Electronic Devices Marketing Division  
421-8, Hino, Hino-shi  
Tokyo 191-8501, Japan  
Tel: 042-587-5812  
Fax: 042-587-5564  
<http://www.epson.co.jp>

#### North America

Epson Electronics America, Inc.  
150 River Oaks Parkway  
San Jose, CA 95134, USA  
Tel: (408) 922-0200  
Fax: (408) 922-0238  
<http://www.eea.epson.com>

#### Taiwan, R.O.C.

Epson Taiwan Technology  
& Trading Ltd.  
10F, No. 287  
Nanking East Road  
Sec. 3, Taipei, Taiwan, R.O.C.  
Tel: 02-2717-7360  
Fax: 02-2712-9164

#### Hong Kong

Epson Hong Kong Ltd.  
20/F., Harbour Centre  
25 Harbour Road  
Wanchai, Hong Kong  
Tel: 2585-4600  
Fax: 2827-4346

#### Europe

Epson Europe Electronics GmbH  
Riesstrasse 15  
80992 Munich, Germany  
Tel: 089-14005-0  
Fax: 089-14005-110

#### Singapore

Epson Singapore Pte., Ltd.  
No. 1  
Temasek Avenue #36-00  
Millenia Tower  
Singapore, 039192  
Tel: 337-7911  
Fax: 334-2716

### 7.2 NEC Electronics Inc.

#### NEC Electronics Inc. (U.S.A.)

Santa Clara  
California  
Tel: (800) 366-9782  
Fax: (800) 729-9288  
<http://www.nec.com>

**THIS PAGE LEFT BLANK**

# EPSON®



## SED1375 Embedded Memory LCD Controller

# Interfacing to the PC Card Bus

Document Number: X27A-G-009-01

Copyright © 1999 Epson Research and Development, Inc. All Rights Reserved.

Information in this document is subject to change without notice. You may download and use this document, but only for your own use in evaluating Seiko Epson/EPSON products. You may not modify the document. Epson Research and Development, Inc. disclaims any representation that the contents of this document are accurate or current. The Programs/Technologies described in this document may contain material protected under U.S. and/or International Patent laws.

EPSON is a registered trademark of Seiko Epson Corporation. All other trademarks are the property of their respective owners.

---

**THIS PAGE LEFT BLANK**

# Table of Contents

<b>1</b>	<b>Introduction</b>	<b>7</b>
<b>2</b>	<b>Interfacing to the PC Card Bus</b>	<b>8</b>
2.1	The PC Card System Bus	8
2.1.1	PC Card Overview	8
2.1.2	Memory Access Cycles	8
<b>3</b>	<b>SED1375 Bus Interface</b>	<b>10</b>
3.1	Host Bus Pin Connection	10
3.2	Generic #2 Interface Mode	11
<b>4</b>	<b>PC Card to SED1375 Interface</b>	<b>12</b>
4.1	Hardware Connections	12
4.2	SED1375 Hardware Configuration	13
4.3	Register/Memory Mapping	13
<b>5</b>	<b>Software</b>	<b>14</b>
<b>6</b>	<b>References</b>	<b>15</b>
6.1	Documents	15
6.2	Document Sources	15
<b>7</b>	<b>Technical Support</b>	<b>16</b>
7.1	EPSON LCD Controllers (SED1375)	16
7.2	PC Card Standard	16

**THIS PAGE LEFT BLANK**



---

## List of Tables

Table 3-1: Host Bus Interface Pin Mapping . . . . .	10
Table 4-1: Summary of Power-On/Reset Options . . . . .	13
Table 4-2: Host Bus Interface Selection . . . . .	13

## List of Figures

Figure 2-1: PC Card Read Cycle . . . . .	9
Figure 2-2: PC Card Write Cycle . . . . .	9
Figure 4-1: Typical Implementation of PC Card to SED1375 Interface . . . . .	12

**THIS PAGE LEFT BLANK**

---

# 1 Introduction

This application note describes the hardware and software environment required to interface the SED1375 Embedded Memory LCD Controller and the PC Card (PCMCIA) bus.

The designs described in this document are presented only as examples of how such interfaces might be implemented. This application note will be updated as appropriate. Please check the Epson Electronics America website at <http://www.eea.epson.com> for the latest revision of this document before beginning any development.

We appreciate your comments on our documentation. Please contact us via email at [techpubs@erd.epson.com](mailto:techpubs@erd.epson.com).

## 2 Interfacing to the PC Card Bus

### 2.1 The PC Card System Bus

PC Card technology has gained wide acceptance in the mobile computing field as well as in other markets due to its portability and ruggedness. This section is an overview of the operation of the 16-bit PC Card interface conforming to the PCMCIA 2.0/JEIDA 4.1 Standard (or later).

#### 2.1.1 PC Card Overview

The 16-bit PC Card provides a 26-bit address bus and additional control lines which allow access to three 64M byte address ranges. These ranges are used for common memory space, IO space, and attribute memory space. Common memory may be accessed by a host system for memory read and write operations. Attribute memory is used for defining card specific information such as configuration registers, card capabilities, and card use. IO space maintains software and hardware compatibility with hosts such as the Intel x86 architecture, which address peripherals independently from memory space.

Bit notation follows the convention used by most microprocessors, the high bit is the most significant. Therefore, signals A25 and D15 are the most significant bits for the address and data bus respectively.

Support is provided for on-chip DMA controllers. To find further information on these topics, refer to Section 6, “References” on page 15.

PC Card bus signals are asynchronous to the host CPU bus signals. Bus cycles are started with the assertion of either the CE1# and/or the CE2# card enable signals. The cycle ends once these signals are de-asserted. Bus cycles can be lengthened using the WAIT# signal.

#### Note

The PCMCIA 2.0/JEIDA 4.1 (and later) PC Card Standard support the two signals WAIT# and RESET which are not supported in earlier versions of the standard. The WAIT# signal allows for asynchronous data transfers for memory, attribute, and IO access cycles. The RESET signal allows resetting of the card configuration by the reset line of the host CPU.

#### 2.1.2 Memory Access Cycles

A data transfer is initiated when the memory address is placed on the PC Card bus and one, or both, of the card enable signals (CE1# and CE2#) are driven low. REG# must be kept inactive. If only CE1# is driven low, 8-bit data transfers are enabled and A0 specifies whether the even or odd data byte appears on data bus lines D[7:0]. If both CE1# and CE2# are driven low, a 16-bit word transfer takes place. If only CE2# is driven low, an odd byte transfer occurs on data lines D[15:8].

During a read cycle, OE# (output enable) is driven low. A write cycle is specified by driving OE# high and driving the write enable signal (WE#) low. The cycle can be lengthened by driving WAIT# low for the time needed to complete the cycle.

Figure 2-1: and Figure 2-2: illustrate typical memory access cycles on the PC Card bus.

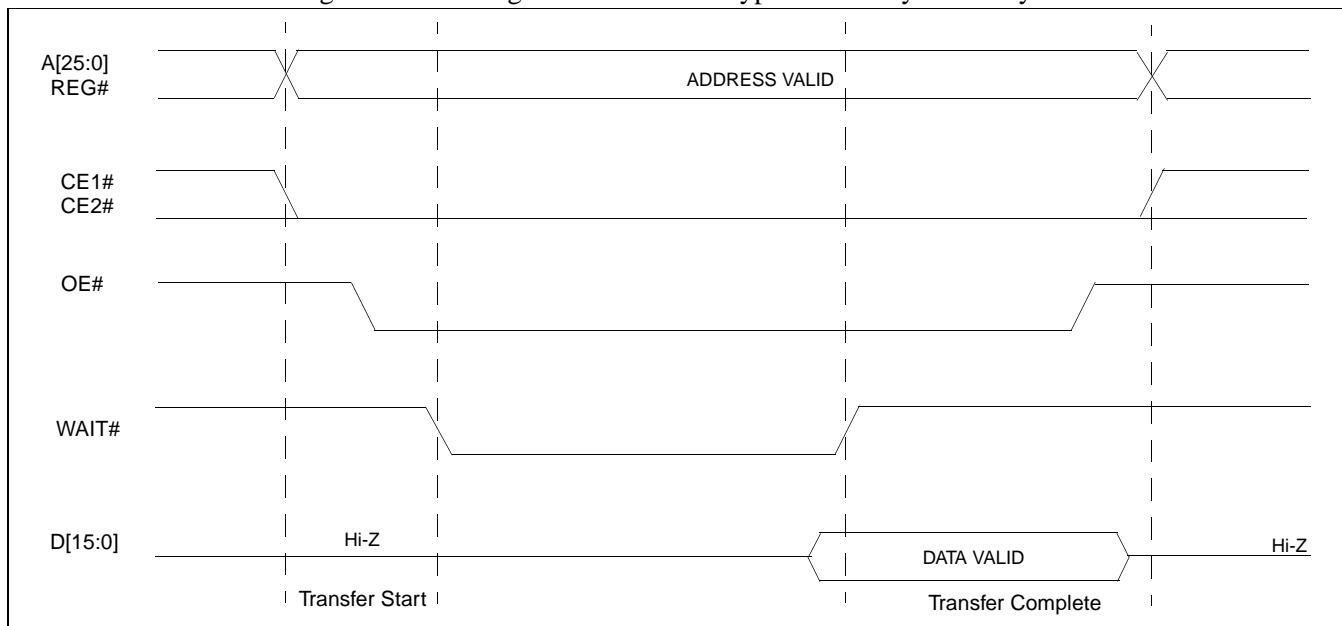

Figure 2-1: PC Card Read Cycle

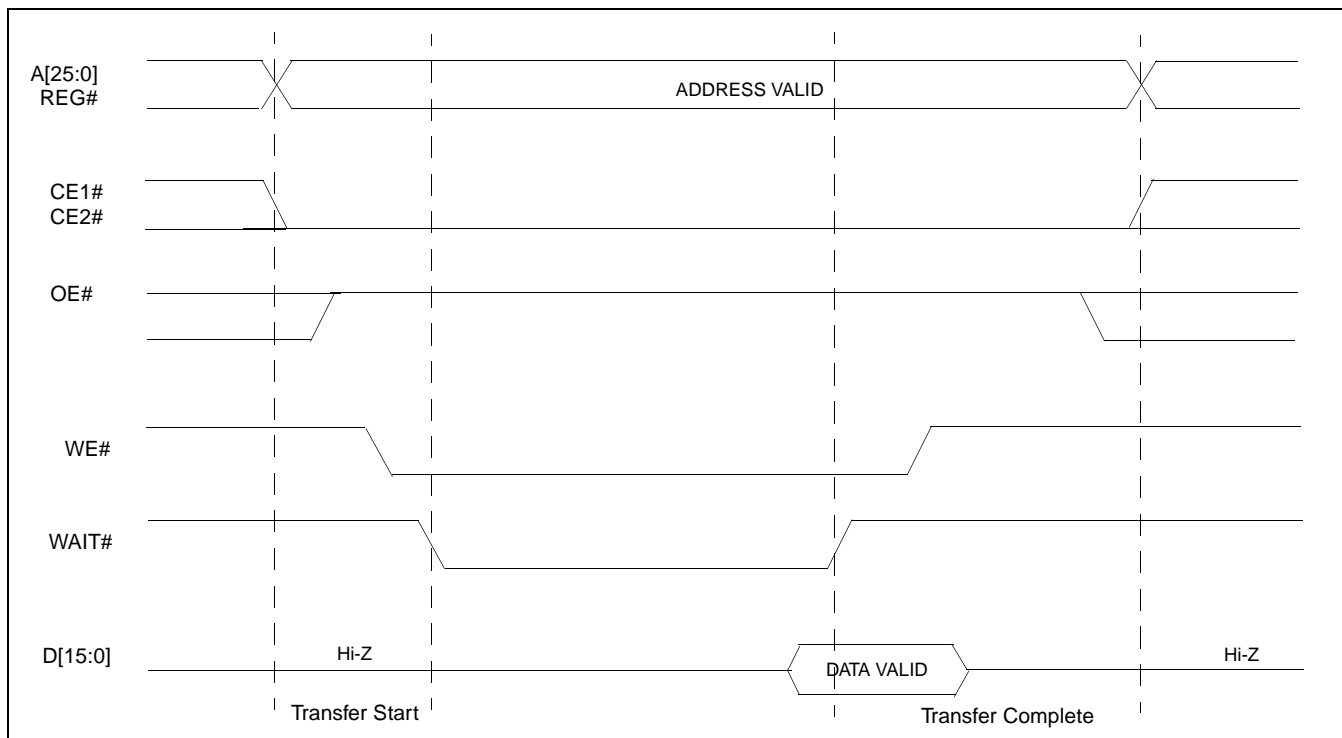

Figure 2-2: PC Card Write Cycle

## 3 SED1375 Bus Interface

This section is a summary of the host bus interface modes available on the SED1375 that would be used to interface to the PC Card bus.

The SED1375 implements a 16-bit interface to the host microprocessor which may operate in one of several modes compatible with most of the popular embedded microprocessor families. The interface mode used for the PC Card bus is:

- Generic #2 (External Chip Select, shared Read/Write Enable for high byte, individual Read/Write Enable for low byte).

### 3.1 Host Bus Pin Connection

The following table shows the functions of the host bus interface signals.

*Table 3-1: Host Bus Interface Pin Mapping*

SED1375 Pin Names	Generic #2
AB[15:1]	A[15:1]
AB0	A0
DB[15:0]	D[15:0]
WE1#	BHE#
CS#	External Decode
BCLK	BCLK
BS#	connect to IO $V_{DD}$
RD/WR#	connect to IO $V_{DD}$
RD#	RD#
WE0#	WE#
WAIT#	WAIT#
RESET#	RESET#

For details on configuration, refer to the *SED1375 Hardware Functional Specification*, document number X27A-A-001-xx.

## 3.2 Generic #2 Interface Mode

Generic #2 interface mode is a general and non-processor-specific interface mode on the SED1375. The Generic # 2 interface mode was chosen for this interface due to the simplicity of its timing and compatibility with the PC Card bus control signals.

The interface requires the following signals:

- BUSCLK is a clock input which synchronizes transfers between the host CPU and the SED1375. It is separate from the input clock (CLKI) and is typically driven by the host CPU system clock.
- The address inputs AB0 through AB16, and the data bus DB0 through DB15, connect directly to the CPU address and data bus, respectively. On 32-bit big endian architectures such as the Power PC, the data bus would connect to the high-order data lines; on little endian hosts, or 16-bit big endian hosts, they would connect to the low-order data lines. The hardware engineer must ensure that CNF3 selects the proper endian mode upon reset.
- Chip Select (CS#) is driven by decoding the high-order address lines to select the proper register and memory address space.
- WE1# is the high byte enable for both read and write cycles.
- WE0# is the write enable for the SED1375, to be driven low when the host CPU is writing data to the SED1375.
- RD# is the read enable for the SED1375, to be driven low when the host CPU is reading data from the SED1375.
- WAIT# is a signal which is output from the SED1375 to the host CPU that indicates when data is ready (read cycle) or accepted (write cycle) on the host bus. Since host CPU accesses to the SED1375 may occur asynchronously to the display update, it is possible that contention may occur in accessing the 1375 internal registers and/or refresh memory. The WAIT# line resolves these contentions by forcing the host to wait until the resource arbitration is complete. This signal is active low and may need to be inverted if the host CPU wait state signal is active high.
- The Bus Status (BS#) and Read/Write (RD/WR#) signals are not used in the bus interface for Generic #2 mode. However, BS# is used to configure the SED1375 for Generic #2 mode and should be tied high (connected to IO  $V_{DD}$ ). RD/WR# should also be tied high.

## 4 PC Card to SED1375 Interface

### 4.1 Hardware Connections

The SED1375 is interfaced to the PC Card bus with a minimal amount of glue logic. In this implementation, the address inputs (AB[16:0]) and data bus (DB[15:0]) connect directly to the CPU address (A[16:0]) and data bus (D[15:0]).

The PC Card interface does not provide a bus clock, so one must be supplied for the SED1375. Since the bus clock frequency is not critical, nor does it have to be synchronous to the bus signals, it may be the same as CLKI.

BS# (bus start) is not used by Generic #2 mode but is used to configure the SED1375 for either Generic #1 or Generic #2 bus and should be tied high (connected to IO V<sub>DD</sub>).

RD/WR# is also not used by Generic #2 bus and should be tied high (connected to IO V<sub>DD</sub>).

The following diagram shows a typical implementation of the PC Card to SED1375 interface.

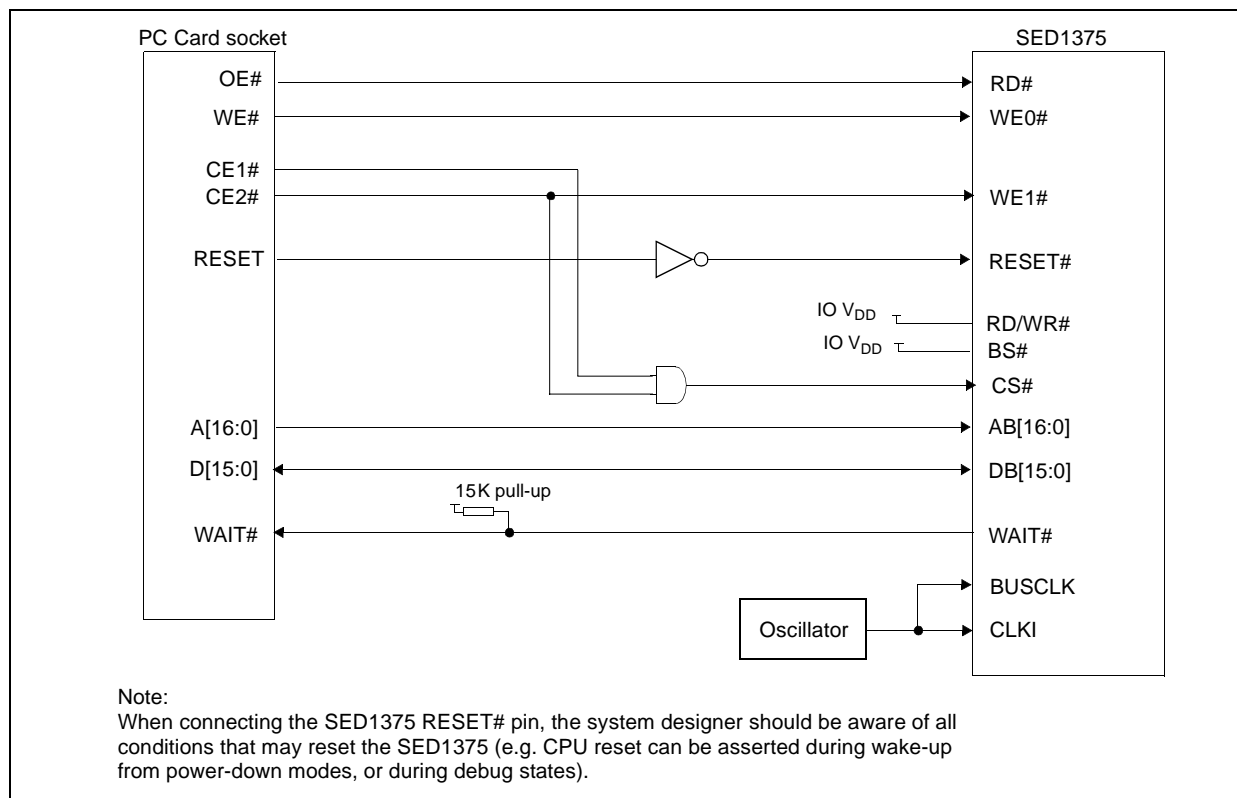

Figure 4-1: Typical Implementation of PC Card to SED1375 Interface



## 4.2 SED1375 Hardware Configuration

The SED1375 uses CNF3 through CNF0 and BS# to allow selection of the bus mode and other configuration data on the rising edge of RESET#. Refer to the *SED1375 Hardware Functional Specification*, document number X27A-A-001-xx for details.

The tables below show only those configuration settings important to the PC Card host bus interface.

*Table 4-1: Summary of Power-On/Reset Options*

Signal	Low	High
CNF0	See "Host Bus Selection" table below	See "Host Bus Selection" table below
CNF1		
CNF2		
CNF3	Little Endian	Big Endian
	= configuration for PC Card host bus interface	

*Table 4-2: Host Bus Interface Selection*

CNF2	CNF1	CNF0	BS#	Host Bus Interface
1	1	1	1	Generic #2, 16-bit
	= configuration for PC Card host bus interface			

## 4.3 Register/Memory Mapping

The SED1375 is a memory mapped device. The SED1375 memory may be addressed starting at 0000h, or on consecutive 128K byte blocks, and its internal registers are located in the upper 32 bytes of the 128K byte block (i.e. REG[0] = 1FFE0h).

While the PC Card socket provides 64M bytes of memory address space, the SED1375 only needs a 128K byte block of memory to accommodate its 80K byte display buffer and its 32 byte register set. For this reason only address bits A[16:0] are used while A[25:17] are ignored. Because the entire 64M bytes of memory is available, the SED1375's memory and registers will be aliased every 128K bytes for a total of 512 times.

### Note

If aliasing is not desirable, the upper addresses must be fully decoded.

## 5 Software

Test utilities and Windows® CE v2.0 display drivers are available for the SED1375. Full source code is available for both the test utilities and the drivers.

The test utilities are configurable for different panel types using a program called 1375CFG, or by directly modifying the source. The Windows CE v2.0 display drivers can be customized by the OEM for different panel types, resolutions and color depths only by modifying the source.

The SED1375 test utilities and Windows CE v2.0 display drivers are available from your sales support contact or on the internet at <http://www.eea.epson.com>.

---

## 6 References

### 6.1 Documents

- PC Card (PCMCIA) Standard March 1997
- Epson Research and Development, Inc., *SED1375 Embedded Memory Color LCD Controller Hardware Functional Specification*; Document Number X27A-A-001-xx.
- Epson Research and Development, Inc., *SDU1375B0C Rev. 1.0 ISA Bus Evaluation Board User Manual*; Document Number X27A-G-005-xx.
- Epson Research and Development, Inc., *SED1375 Programming Notes and Examples*; Document Number X27A-G-002-xx.

### 6.2 Document Sources

- PC Card website: <http://www.pc-card.com>.
- Epson Electronics America website: <http://www.eea.epson.com>

## 7 Technical Support

### 7.1 EPSON LCD Controllers (SED1375)

**Japan**

Seiko Epson Corporation  
Electronic Devices Marketing Division  
421-8, Hino, Hino-shi  
Tokyo 191-8501, Japan  
Tel: 042-587-5812  
Fax: 042-587-5564  
<http://www.epson.co.jp>

**North America**

Epson Electronics America, Inc.  
150 River Oaks Parkway  
San Jose, CA 95134, USA  
Tel: (408) 922-0200  
Fax: (408) 922-0238  
<http://www.eea.epson.com>

**Taiwan, R.O.C.**

Epson Taiwan Technology  
& Trading Ltd.  
10F, No. 287  
Nanking East Road  
Sec. 3, Taipei, Taiwan, R.O.C.  
Tel: 02-2717-7360  
Fax: 02-2712-9164

**Hong Kong**

Epson Hong Kong Ltd.  
20/F., Harbour Centre  
25 Harbour Road  
Wanchai, Hong Kong  
Tel: 2585-4600  
Fax: 2827-4346

**Europe**

Epson Europe Electronics GmbH  
Riesstrasse 15  
80992 Munich, Germany  
Tel: 089-14005-0  
Fax: 089-14005-110

**Singapore**

Epson Singapore Pte., Ltd.  
No. 1  
Temasek Avenue #36-00  
Millenia Tower  
Singapore, 039192  
Tel: 337-7911  
Fax: 334-2716

### 7.2 PC Card Standard

**PCMCIA**

**(Personal Computer Memory Card International Association)**

2635 North First Street, Suite 209  
San Jose, CA 95134  
Tel: (408) 433-2273  
Fax: (408) 433-9558  
<http://www.pc-card.com>

# EPSON®



## SED1375 Embedded Memory LCD Controller

# Interfacing to the Motorola MPC821 Microprocessor

Document Number: X27A-G-010-01

Copyright © 1999 Epson Research and Development, Inc. All Rights Reserved.

Information in this document is subject to change without notice. You may download and use this document, but only for your own use in evaluating Seiko Epson/EPSON products. You may not modify the document. Epson Research and Development, Inc. disclaims any representation that the contents of this document are accurate or current. The Programs/Technologies described in this document may contain material protected under U.S. and/or International Patent laws.

EPSON is a registered trademark of Seiko Epson Corporation. All Trademarks are the property of their respective owners.

---

**THIS PAGE LEFT BLANK**

# Table of Contents

<b>1</b>	<b>Introduction</b>	<b>7</b>
<b>2</b>	<b>Interfacing to the MPC821</b>	<b>8</b>
2.1	The MPC8xx System Bus	8
2.2	MPC821 Bus Overview	8
2.2.1	Normal (Non-Burst) Bus Transactions	9
2.2.2	Burst Cycles	10
2.3	Memory Controller Module	11
2.3.1	General-Purpose Chip Select Module (GPCM)	11
2.3.2	User-Programmable Machine (UPM)	12
<b>3</b>	<b>SED1375 Host Bus Interface</b>	<b>13</b>
3.1	Host Bus Interface Modes	13
3.2	Generic #1 Host Bus Interface Mode	14
<b>4</b>	<b>MPC821 to SED1375 Interface</b>	<b>15</b>
4.1	Hardware Description	15
4.2	MPC821ADS Evaluation Board Hardware Connections	16
4.3	SED1375 Hardware Configuration	18
4.4	MPC821 Chip Select Configuration	19
4.5	Test Software	20
<b>5</b>	<b>Software</b>	<b>22</b>
<b>6</b>	<b>References</b>	<b>23</b>
6.1	Documents	23
6.2	Document Sources	23
<b>7</b>	<b>Technical Support</b>	<b>24</b>
7.1	EPSON LCD/CRT Controllers (SED1375)	24
7.2	Motorola MPC821 Processor	24

**THIS PAGE LEFT BLANK**



---

## List of Tables

Table 3-1: Host Bus Interface Pin Mapping . . . . .	13
Table 4-1: List of Connections from MPC821ADS to SED1375 . . . . .	16
Table 4-2: Configuration Settings . . . . .	18
Table 4-3: Host Bus Selection . . . . .	18

## List of Figures

Figure 2-1: Power PC Memory Read Cycle . . . . .	9
Figure 2-2: Power PC Memory Write Cycle . . . . .	10
Figure 4-1: Typical Implementation of MPC821 to SED1375 Interface . . . . .	15

**THIS PAGE LEFT BLANK**

---

# 1 Introduction

This application note describes the hardware and software environment required to interface the SED1375 Embedded Memory LCD Controller and the Motorola MPC821 Processor.

The designs described in this document are presented only as examples of how such interfaces might be implemented. This application note will be updated as appropriate. Please check the Epson Electronics America website at <http://www.eea.epson.com> for the latest revision of this document before beginning any development.

We appreciate your comments on our documentation. Please contact us via email at [techpubs@erd.epson.com](mailto:techpubs@erd.epson.com).

## 2 Interfacing to the MPC821

### 2.1 The MPC8xx System Bus

The MPC8xx family of processors feature a high-speed synchronous system bus typical of modern RISC microprocessors. This section provides an overview of the operation of the CPU bus in order to establish interface requirements.

### 2.2 MPC821 Bus Overview

The MPC8xx microprocessor family uses a synchronous address and data bus. All IO is synchronous to a square-wave reference clock called MCLK (Master Clock). This clock runs at the machine cycle speed of the CPU core (typically 25 to 50 MHz). Most outputs from the processor change state on the rising edge of this clock. Similarly, most inputs to the processor are sampled on the rising edge.

#### Note

The external bus can run at one-half the CPU core speed using the clock control register. This is typically used when the CPU core is operated above 50 MHz.

The MPC821 can generate up to eight independent chip select outputs, each of which may be controlled by one of two types of timing generators: the General Purpose Chip Select Module (GPCM) or the User-Programmable Machine (UPM). Examples are given using the GPCM.

It should be noted that all Power PC microprocessors, including the MPC8xx family, use bit notation opposite from the convention used by most other microprocessor systems. Bit numbering for the MPC8xx always starts with zero as the most significant bit, and increments in value to the least-significant bit. For example, the most significant bits of the address bus and data bus are A0 and D0, while the least significant bits are A31 and D31.

The MPC8xx uses both a 32-bit address and data bus. A parity bit is supported for each of the four byte lanes on the data bus. Parity checking is done when data is read from external memory or peripherals, and generated by the MPC8xx bus controller on write cycles. All IO accesses are memory-mapped meaning there is no separate IO space in the Power PC architecture.

Support is provided for both on-chip (DMA controllers) and off-chip (other processors and peripheral controllers) bus masters. For further information on this topic, refer to Section 6, "References" on page 23.

The bus can support both normal and burst cycles. Burst memory cycles are used to fill on-chip cache memory, and for certain on-chip DMA operations. Normal cycles are used for all other data transfers.

## 2.2.1 Normal (Non-Burst) Bus Transactions

A data transfer is initiated by the bus master by placing the memory address on address lines A0 through A31 and driving  $\overline{TS}$  (Transfer Start) low for one clock cycle. Several control signals are also provided with the memory address:

- TSIZ[0:1] (Transfer Size) -- indicates whether the bus cycle is 8, 16, or 32-bit.
- RD/ $\overline{WR}$  -- set high for read cycles and low for write cycles.
- AT[0:3] (Address Type Signals) -- provides more detail on the type of transfer being attempted.

When the peripheral device being accessed has completed the bus transfer, it asserts  $\overline{TA}$  (Transfer Acknowledge) for one clock cycle to complete the bus transaction. Once  $\overline{TA}$  has been asserted, the MPC821 will not start another bus cycle until  $\overline{TA}$  has been de-asserted. The minimum length of a bus transaction is two bus clocks.

Figure 2-1: “Power PC Memory Read Cycle” illustrates a typical memory read cycle on the Power PC system bus.

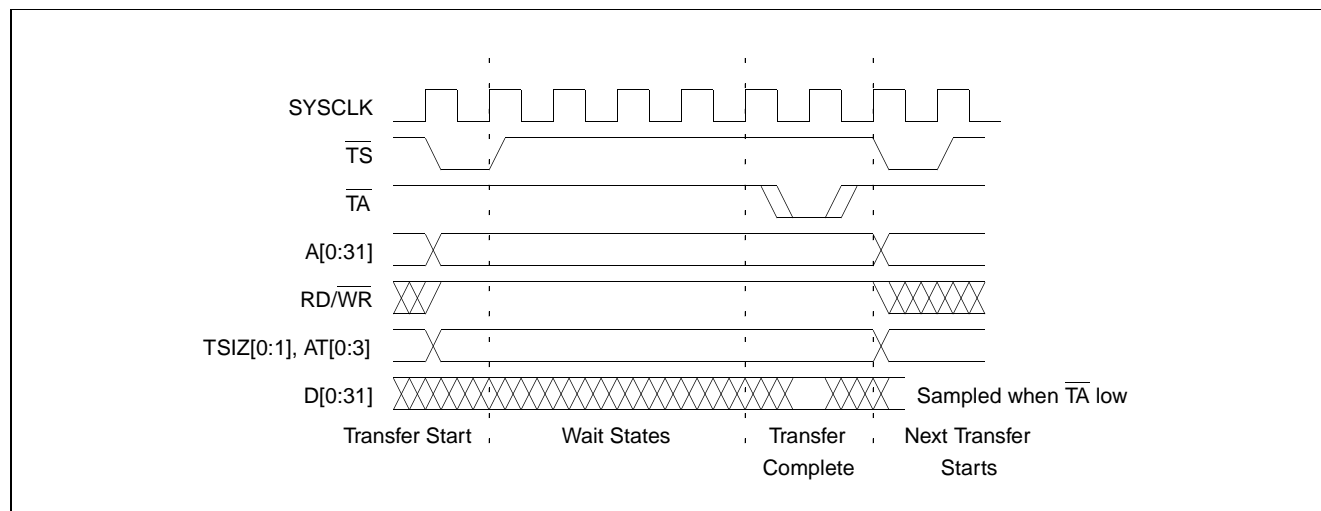

Figure 2-1: Power PC Memory Read Cycle

Figure 2-2: “Power PC Memory Write Cycle” illustrates a typical memory write cycle on the Power PC system bus.

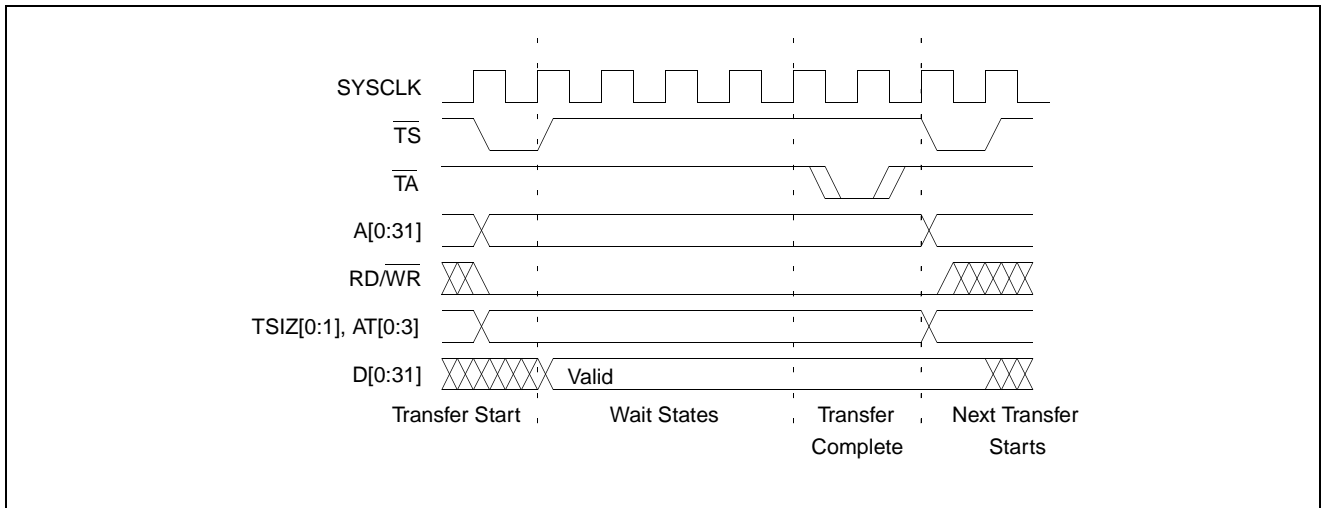

Figure 2-2: Power PC Memory Write Cycle

If an error occurs,  $\overline{TEA}$  (Transfer Error Acknowledge) is asserted and the bus cycle is aborted. For example, a peripheral device may assert  $\overline{TEA}$  if a parity error is detected, or the MPC821 bus controller may assert  $\overline{TEA}$  if no peripheral device responds at the addressed memory location within a bus time-out period.

For 32-bit transfers, all data lines (D[0:31]) are used and the two low-order address lines A30 and A31 are ignored. For 16-bit transfers, data lines D0 through D15 are used and address line A30 is ignored. For 8-bit transfers, data lines D0 through D7 are used and all address lines (A[0:31]) are used.

#### Note

This assumes that the Power PC core is operating in big endian mode (typically the case for embedded systems).

## 2.2.2 Burst Cycles

Burst memory cycles are used to fill on-chip cache memory and to carry out certain on-chip DMA operations. They are very similar to normal bus cycles with the following exceptions:

- Always 32-bit.
- Always attempt to transfer four 32-bit words sequentially.
- Always address longword-aligned memory (i.e. A30 and A31 are always 0:0).
- Do not increment address bits A28 and A29 between successive transfers; the addressed device must increment these address bits internally.

If a peripheral is not capable of supporting burst cycles, it can assert Burst Inhibit ( $\overline{\text{BI}}$ ) simultaneously with  $\overline{\text{TA}}$ , and the processor will revert to normal bus cycles for the remaining data transfers.

Burst cycles are mainly intended to facilitate cache line fills from program or data memory. They are normally not used for transfers to/from IO peripheral devices such as the SED1375, therefore the interfaces described in this document do not attempt to support burst cycles. However, the example interfaces include circuitry to detect the assertion of  $\overline{\text{BDIP}}$  and respond with  $\overline{\text{BI}}$  if caching is accidentally enabled for the SED1375 address space.

## 2.3 Memory Controller Module

### 2.3.1 General-Purpose Chip Select Module (GPCM)

The General-Purpose Chip Select Module (GPCM) is used to control memory and peripheral devices which do not require special timing or address multiplexing. In addition to the chip select output, it can generate active-low Output Enable ( $\overline{\text{OE}}$ ) and Write Enable ( $\overline{\text{WE}}$ ) signals compatible with most memory and x86-style peripherals. The MPC821 bus controller also provides a Read/Write ( $\text{RD}/\overline{\text{WR}}$ ) signal which is compatible with most 68K peripherals.

The GPCM is controlled by the values programmed into the Base Register (BR) and Option Register (OR) of the respective chip select. The Option Register sets the base address, the block size of the chip select, and controls the following timing parameters:

- The ACS bit field allows the chip select assertion to be delayed with respect to the address bus valid, by 0, 1/4, or 1/2 clock cycle.
- The CSNT bit causes chip select and  $\overline{\text{WE}}$  to be negated 1/2 clock cycle earlier than normal.
- The TRLX (relaxed timing) bit will insert an additional one clock delay between assertion of the address bus and chip select. This accommodates memory and peripherals with long setup times.
- The EHTR (Extended hold time) bit will insert an additional 1-clock delay on the first access to a chip select.
- Up to 15 wait states may be inserted, or the peripheral can terminate the bus cycle itself by asserting  $\overline{\text{TA}}$  (Transfer Acknowledge).
- Any chip select may be programmed to assert  $\overline{\text{BI}}$  (Burst Inhibit) automatically when its memory space is addressed by the processor core.

### 2.3.2 User-Programmable Machine (UPM)

The UPM is typically used to control memory types, such as Dynamic RAMs, which have complex control or address multiplexing requirements. The UPM is a general purpose RAM-based pattern generator which can control address multiplexing, wait state generation, and five general-purpose output lines on the MPC821. Up to 64 pattern locations are available, each 32 bits wide. Separate patterns may be programmed for normal accesses, burst accesses, refresh (timer) events, and exception conditions. This flexibility allows almost any type of memory or peripheral device to be accommodated by the MPC821.

In this application note, the GPCM is used instead of the UPM, since the GPCM has enough flexibility to accommodate the SED1375 and it is desirable to leave the UPM free to handle other interfacing duties, such as EDO DRAM.



## 3 SED1375 Host Bus Interface

This section is a summary of the host bus interface mode used on the SED1375 to interface to the MPC821.

The SED1375 implements a 16-bit interface to the host microprocessor which may operate in one of several modes compatible with most of the popular embedded microprocessor families. The interface mode used for the MPC821 is:

- Generic #1 (Chip Select, plus individual Read Enable/Write Enable for each byte).

### 3.1 Host Bus Interface Modes

Table 3-1: Host Bus Interface Pin Mapping

SED1375 Pin Names	Generic #1
AB[15:1]	A[15:1]
AB0	A0
DB[15:0]	D[15:0]
WE1#	WE1#
CS#	External Decode
BCLK	BCLK
BS#	connect to $V_{SS}$
RD/WR#	RD1#
RD#	RD0#
WE0#	WE0#
WAIT#	WAIT#
RESET#	RESET#

For details on configuration, refer to the *SED1375 Hardware Functional Specification*, document number X27A-A-001-xx.

## 3.2 Generic #1 Host Bus Interface Mode

Generic #1 host bus interface mode is the most general and least processor-specific host bus interface mode on the SED1375. The Generic # 1 host bus interface mode was chosen for this interface due to the simplicity of its timing.

The host bus interface requires the following signals:

- BUSCLK is a clock input which is required by the SED1375 host interface. It is separate from the input clock (CLKI) and is typically driven by the host CPU system clock.
- The address inputs AB0 through AB16, and the data bus DB0 through DB15, connect directly to the CPU address and data bus, respectively. On 32-bit big endian architectures such as the Power PC, the data bus would connect to the high-order data lines; on little endian hosts, or 16-bit big endian hosts, they would connect to the low-order data lines. The hardware engineer must ensure that CNF3 selects the proper endian mode upon reset.
- Chip Select (CS#) is driven by decoding the high-order address lines to select the proper IO or memory address space.
- WE0# and WE1# are write enables for the low-order and high-order bytes, respectively, to be driven low when the host CPU is writing data to the SED1375.
- RD# and RD/WR# are read enables for the low-order and high-order bytes, respectively, to be driven low when the host CPU is reading data from the SED1375.
- WAIT# is a signal output from the SED1375 that indicates the host CPU must wait until data is ready (read cycle) or accepted (write cycle) on the host bus. Since host CPU accesses to the SED1375 may occur asynchronously to the display update, it is possible that contention may occur in accessing the SED1375 internal registers and/or refresh memory. The WAIT# line resolves these contentions by forcing the host to wait until the resource arbitration is complete. This signal is active low and may need to be inverted if the host CPU wait state signal is active high.
- The Bus Status (BS#) signal is not used in the bus interface for Generic #1 mode. However, BS# is used to configure the SED1375 for Generic #1 mode and should be tied low (connected to GND).

## 4 MPC821 to SED1375 Interface

### 4.1 Hardware Description

The interface between the SED1375 and the MPC821 requires minimal glue logic. One inverter is required to change the polarity of the WAIT# signal (an active low signal) to insert wait states in the bus cycle. The MPC821 Transfer Acknowledge signal ( $\overline{TA}$ ) is an active low signal which ends the current bus cycle. The inverter is enabled using CS# so that  $\overline{TA}$  is not driven by the SED1375 during non-SED1375 bus cycles. A single resistor is used to speed up the rise time of the WAIT# ( $\overline{TA}$ ) signal when terminating the bus cycle.

BS# (bus start) is not used in this implementation and should be tied low (connected to GND).

The following diagram shows a typical implementation of the MPC821 to SED1375 interface.

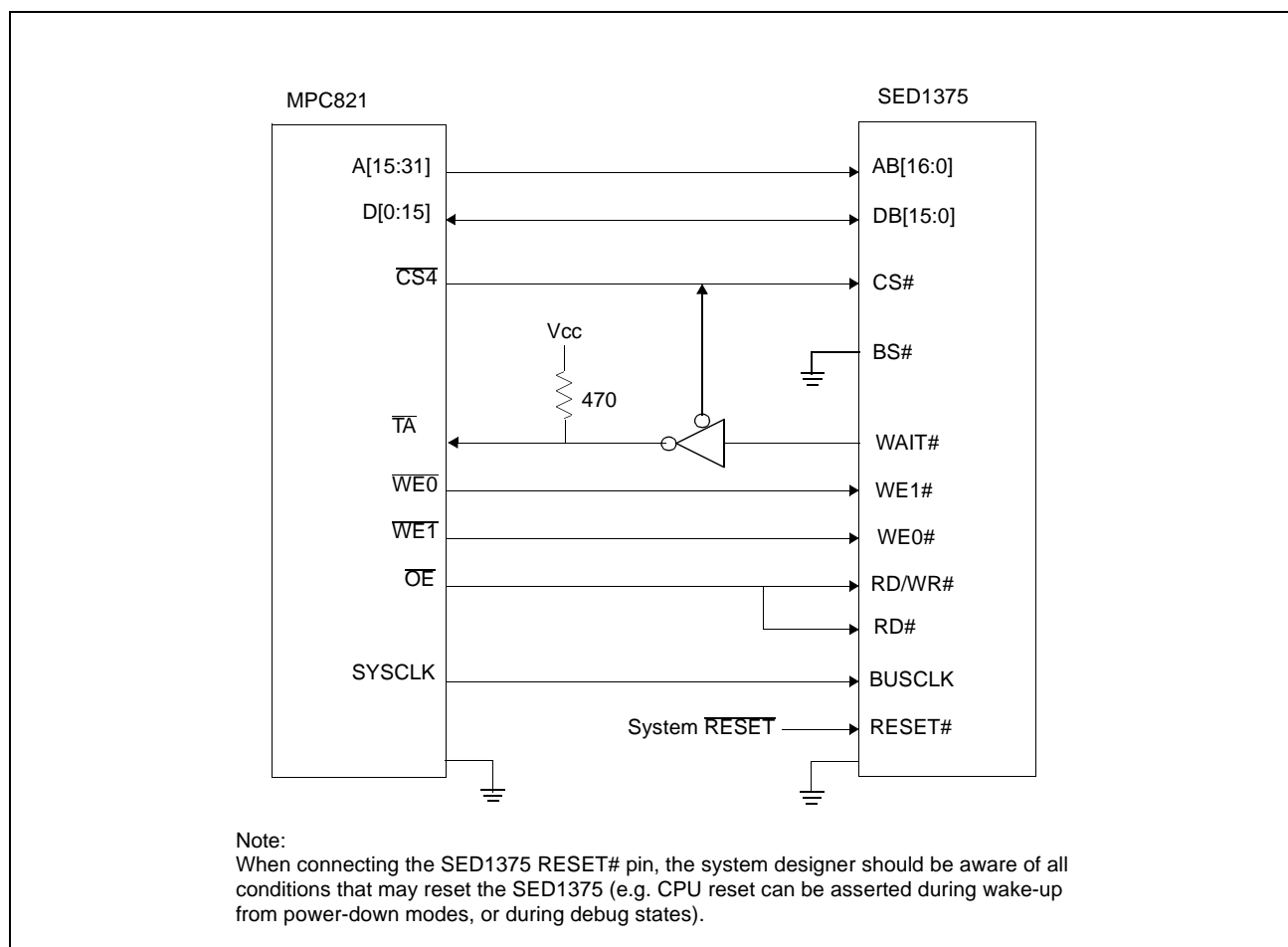

Figure 4-1: Typical Implementation of MPC821 to SED1375 Interface

## 4.2 MPC821ADS Evaluation Board Hardware Connections

The following table details the connections between the pins and signals of the MPC821 and the SED1375.

*Table 4-1: List of Connections from MPC821ADS to SED1375*

MPC821 Signal Name	MPC821ADS Connector and Pin Name	SED1375 Signal Name
Vcc	P6-A1, P6-B1	Vcc
A15	P6-D20	A16
A16	P6-B24	A15
A17	P6-C24	A14
A18	P6-D23	A13
A19	P6-D22	A12
A20	P6-D19	A11
A21	P6-A19	A10
A22	P6-D28	A9
A23	P6-A28	A8
A24	P6-C27	A7
A25	P6-A26	A6
A26	P6-C26	A5
A27	P6-A25	A4
A28	P6-D26	A3
A29	P6-B25	A2
A30	P6-B19	A1
A31	P6-D17	A0
D0	P12-A9	D15
D1	P12-C9	D14
D2	P12-D9	D13
D3	P12-A8	D12
D4	P12-B8	D11
D5	P12-D8	D10
D6	P12-B7	D9
D7	P12-C7	D8
D8	P12-A15	D7
D9	P12-C15	D6
D10	P12-D15	D5
D11	P12-A14	D4
D12	P12-B14	D3
D13	P12-D14	D2
D14	P12-B13	D1
D15	P12-C13	D0
SRESET	P9-D15	RESET#
SYSCLK	P9-C2	BUSCLK

*Table 4-1: List of Connections from MPC821ADS to SED1375 (Continued)*

MPC821 Signal Name	MPC821ADS Connector and Pin Name	SED1375 Signal Name
CS4	P6-D13	CS#
TA	P6-B6 to inverter enabled by CS#	WAIT#
WE0	P6-B15	WE1#
WE1	P6-A14	WE0#
OE	P6-B16	RD/WR#, RD#
GND	P12-A1, P12-B1, P12-A2, P12-B2, P12-A3, P12-B3, P12-A4, P12-B4, P12-A5, P12-B5, P12-A6, P12-B6, P12-A7	Vss

**Note**

The bit numbering of the Power PC bus signals is reversed from the normal convention, e.g.: the most significant address bit is A0, the next is A1, A2, etc.

## 4.3 SED1375 Hardware Configuration

The SED1375 uses CNF3 through CNF0 and BS# to allow selection of the bus mode and other configuration data on the rising edge of RESET#. Refer to the *SED1375 Hardware Functional Specification*, document number X27A-A-001-xx for details.

The tables below show only those configuration settings important to the MPC821 interface. The settings are very similar to the ISA bus with the following exceptions:

- the WAIT# signal is active high rather than active low.
- the Power PC is big endian rather than little endian.

*Table 4-2: Configuration Settings*

Signal	Low	High
CNF0	See "Host Bus Selection" table below	See "Host Bus Selection" table below
CNF1		
CNF2		
CNF3	Little Endian	Big Endian
	= configuration for MPC821 host bus interface	

*Table 4-3: Host Bus Selection*

CNF2	CNF1	CNF0	BS#	Host Bus Interface
1	1	1	0	Generic #1, 16-bit
	= configuration for MPC821 host bus interface			

## 4.4 MPC821 Chip Select Configuration

The DRAM on the MPC821 ADS board extends from address 0 through 3F FFFFh, so the SED1375 is addressed starting at 40 0000h. The SED1375 uses a 128K byte segment of memory starting at this address, with the first 80K bytes used for the display buffer and the upper 32 bytes of this memory block used for the SED1375 internal registers.

Chip select 4 is used to control the SED1375. The following options are selected in the base address register (BR4):

- BA (0:16) = 0000 0000 0100 0000 0 – set starting address of SED1375 to 40 0000h
- AT (0:2) = 0 – ignore address type bits
- PS (0:1) = 1:0 – memory port size is 16 bits
- PARE = 0 – disable parity checking
- WP = 0 – disable write protect
- MS (0:1) = 0:0 – select General Purpose Chip Select module to control this chip select
- V = 1 – set valid bit to enable chip select

The following options were selected in the option register (OR4):

- AM (0:16) = 1111 1111 1100 0000 0 – mask all but upper 10 address bits; SED1375 consumes 4M byte of address space
- ATM (0:2) = 0 – ignore address type bits
- CSNT = 0 – normal  $\overline{CS}/\overline{WE}$  negation
- ACS (0:1) = 1:1 – delay  $\overline{CS}$  assertion by  $\frac{1}{2}$  clock cycle from address lines
- BI = 1 – assert Burst Inhibit
- SCY (0:3) = 0 – wait state selection; this field is ignored since external transfer acknowledge is used; see SETA below
- SETA = 1 – the SED1375 generates an external transfer acknowledge using the WAIT# line
- TRLX = 0 – normal timing
- EHTR = 0 – normal timing

## 4.5 Test Software

The test software to exercise this interface is very simple. It configures chip select 4 on the MPC821 to map the SED1375 to an unused 128k byte block of address space and loads the appropriate values into the option register for CS4. At that point the software runs in a tight loop reading the 1375 Revision Code Register REG[00h], which allows monitoring of the bus timing on a logic analyzer.

The source code for this test routine is as follows:

```
BR4      equ      $120          ; CS4 base register
OR4      equ      $124          ; CS4 option register
MemStart equ      $40           ; upper word of SED1375 start address
RevCodeReg equ     1FFE0        ; address of Revision Code Register

Start    mfspr     r1,IMMR       ; get base address of internal registers
         andis.   r1,r1,$ffff    ; clear lower 16 bits to 0
         andis.   r2,r0,0        ; clear r2
         oris    r2,r2,MemStart  ; write base address
         ori     r2,r2,$0801     ; port size 16 bits; select GPCM; enable
         stw     r2,BR4(r1)     ; write value to base register
         andis.   r2,r0,0        ; clear r2
         oris    r2,r2,$ffc0     ; address mask - use upper 10 bits
         ori     r2,r2,$0708     ; normal CS negation; delay CS ½ clock;
                                 ; inhibit burst
         stw     r2,OR4(r1)     ; write to option register
         andis.   r1,r0,0        ; clear r1
         oris    r1,r1,MemStart  ; point r1 to start of SED1375 mem space
Loop     lbz     r0,RevCodeReg(r1) ; read revision code into r1
         b       Loop          ; branch forever

end
```



This code was entered into the memory of the MPC821ADS using the line-by-line assembler in MPC8BUG, the debugger provided with the ADS board. It was executed on the ADS and a logic analyzer was used to verify operation of the interface hardware.

**Note**

MPC8BUG does not support comments or symbolic equates; these have been added for clarity.

It is important to note that when the MPC821 comes out of reset, its on-chip caches and MMU are disabled. If the data cache is enabled, then the MMU must be set up so that the SED1375 memory block is tagged as non-cacheable, to ensure that accesses to the SED1375 will occur in proper order, and also to ensure that the MPC821 does not attempt to cache any data read from or written to the SED1375 or its display buffer.

## 5 Software

Test utilities and Windows® CE v2.0 display drivers are available for the SED1375. Full source code is available for both the test utilities and the drivers.

The test utilities are configurable for different panel types using a program called 1375CFG, or by directly modifying the source. The Windows CE v2.0 display drivers can be customized by the OEM for different panel types, resolutions and color depths only by modifying the source.

The SED1375 test utilities and Windows CE v2.0 display drivers are available from your sales support contact or on the internet at <http://www.eea.epson.com>.

---

## 6 References

### 6.1 Documents

- Motorola Inc., *Power PC MPC821 Portable Systems Microprocessor User's Manual*, Motorola Publication no. MPC821UM/AD; available on the Internet at [http://www.mot.com/SPS/ADC/pps/\\_subpgs/\\_documentation/821/821UM.html](http://www.mot.com/SPS/ADC/pps/_subpgs/_documentation/821/821UM.html).
- Epson Research and Development, Inc., *SED1375 Embedded Memory LCD Controller Hardware Functional Specification*; Document Number X27A-A-002-xx.
- Epson Research and Development, Inc., *SDU1375B0C Rev. 1.0 ISA Bus Evaluation Board User Manual*; Document Number X27A-G-005-xx.
- Epson Research and Development, Inc., *Programming Notes and Examples*; Document Number X27A-G-002-xx.

### 6.2 Document Sources

- Motorola Inc. Literature Distribution Center: (800) 441-2447.
- Motorola Inc. Website: <http://www.mot.com>.
- Epson Electronics America website: <http://www.eea.epson.com>.

## 7 Technical Support

### 7.1 EPSON LCD/CRT Controllers (SED1375)

**Japan**

Seiko Epson Corporation  
Electronic Devices Marketing Division  
421-8, Hino, Hino-shi  
Tokyo 191-8501, Japan  
Tel: 042-587-5812  
Fax: 042-587-5564  
<http://www.epson.co.jp>

**North America**

Epson Electronics America, Inc.  
150 River Oaks Parkway  
San Jose, CA 95134, USA  
Tel: (408) 922-0200  
Fax: (408) 922-0238  
<http://www.eea.epson.com>

**Taiwan, R.O.C.**

Epson Taiwan Technology  
& Trading Ltd.  
10F, No. 287  
Nanking East Road  
Sec. 3, Taipei, Taiwan, R.O.C.  
Tel: 02-2717-7360  
Fax: 02-2712-9164

**Hong Kong**

Epson Hong Kong Ltd.  
20/F., Harbour Centre  
25 Harbour Road  
Wanchai, Hong Kong  
Tel: 2585-4600  
Fax: 2827-4346

**Europe**

Epson Europe Electronics GmbH  
Riesstrasse 15  
80992 Munich, Germany  
Tel: 089-14005-0  
Fax: 089-14005-110

**Singapore**

Epson Singapore Pte., Ltd.  
No. 1  
Temasek Avenue #36-00  
Millenia Tower  
Singapore, 039192  
Tel: 337-7911  
Fax: 334-2716

### 7.2 Motorola MPC821 Processor

- Motorola Design Line, (800) 521-6274.
- Local Motorola sales office or authorized distributor.

# EPSON®



## SED1375 Embedded Memory LCD Controller

# Interfacing to the Motorola MCF5307 "ColdFire" Microprocessor

Document Number: X27A-G-011-01

Copyright © 1999 Epson Research and Development, Inc. All Rights Reserved.

Information in this document is subject to change without notice. You may download and use this document, but only for your own use in evaluating Seiko Epson/EPSON products. You may not modify the document. Epson Research and Development, Inc. disclaims any representation that the contents of this document are accurate or current. The Programs/Technologies described in this document may contain material protected under U.S. and/or International Patent laws.

EPSON is a registered trademark of Seiko Epson Corporation. All Trademarks are the property of their respective owners.

---

**THIS PAGE LEFT BLANK**

# Table of Contents

<b>1</b>	<b>Introduction</b>	<b>7</b>
<b>2</b>	<b>Interfacing to the MCF5307</b>	<b>8</b>
2.1	The MCF5307 System Bus	8
2.1.1	Overview	8
2.1.2	Normal (Non-Burst) Bus Transactions	8
2.1.3	Burst Cycles	9
2.2	Chip-Select Module	10
<b>3</b>	<b>SED1375 Bus Interface</b>	<b>11</b>
3.1	Host Bus Pin Connection	11
3.2	Generic #1 Interface Mode	12
<b>4</b>	<b>MCF5307 To SED1375 Interface</b>	<b>13</b>
4.1	Hardware Description	13
4.2	SED1375 Hardware Configuration	14
4.3	MCF5307 Chip Select Configuration	15
<b>5</b>	<b>Software</b>	<b>16</b>
<b>6</b>	<b>References</b>	<b>17</b>
6.1	Documents	17
6.2	Document Sources	17
<b>7</b>	<b>Technical Support</b>	<b>18</b>
7.1	EPSON LCD Controllers (SED1375)	18
7.2	Motorola MCF5307 Processor	18

**THIS PAGE LEFT BLANK**



---

## List of Tables

Table 3-1: Host Bus Interface Pin Mapping . . . . .	11
Table 4-1: Summary of Power-On/Reset Options . . . . .	14
Table 4-2: Host Bus Interface Selection . . . . .	14

## List of Figures

Figure 2-1: MCF5307 Memory Read Cycle . . . . .	9
Figure 2-2: MCF5307 Memory Write Cycle . . . . .	9
Figure 4-1: Typical Implementation of MCF5307 to SED1375 Interface . . . . .	13

**THIS PAGE LEFT BLANK**

---

# 1 Introduction

This application note describes the hardware required to interface the SED1375 Embedded Memory LCD Controller and the Motorola MCF5307 Processor. The pairing of these two devices results in an embedded system offering impressive display capability with very low power consumption.

The designs described in this document are presented only as examples of how such interfaces might be implemented. This application note will be updated as appropriate. Please check the Epson Electronics America website at <http://www.eea.epson.com> for the latest revision of this document before beginning any development.

We appreciate your comments on our documentation. Please contact us via email at [techpubs@erd.epson.com](mailto:techpubs@erd.epson.com).

## 2 Interfacing to the MCF5307

### 2.1 The MCF5307 System Bus

The MCF5200/5300 family of processors feature a high-speed synchronous system bus typical of modern microprocessors. This section is an overview of the operation of the CPU bus to establish interface requirements.

#### 2.1.1 Overview

The MCF5307 microprocessor family uses a synchronous address and data bus, very similar in architecture to the MC68040 and MPC8xx. All outputs and inputs are timed with respect to a square-wave reference clock called BCLK0 (Master Clock). This clock runs at a software-selectable divisor rate from the machine cycle speed of the CPU core, typically 20 to 33 MHz. Both the address and the data bus are 32 bits in width. All IO accesses are memory-mapped; there is no separate IO space in the Coldfire architecture.

The bus can support two types of cycles, normal and burst. Burst memory cycles are used to fill on-chip cache memories, and for certain on-chip DMA operations. Normal cycles are used for all other data transfers.

#### 2.1.2 Normal (Non-Burst) Bus Transactions

A data transfer is initiated by the bus master by placing the memory address on address lines A31 through A0 and driving  $\overline{TS}$  (Transfer Start) low for one clock cycle. Several control signals are also provided with the memory address:

- $SIZ[1:0]$  (Transfer Size), which indicate whether the bus cycle is 8, 16, or 32 bits in width.
- $R/\overline{W}$ , which is high for read cycles and low for write cycles.
- A set of transfer type signals ( $TT[1:0]$ ) which provide more detail on the type of transfer being attempted.
- $TIP$  (Transfer In Progress), which is asserted whenever a bus cycle is active.

When the peripheral device being accessed has completed the bus transfer, it asserts  $\overline{TA}$  (Transfer Acknowledge) for one clock cycle, completing the bus transaction. Once  $\overline{TA}$  has been asserted, the MCF5307 will not start another bus cycle until  $\overline{TA}$  has been de-asserted. The minimum length of a bus transaction is two bus clocks.

Figure 2-1 illustrates a typical memory read cycle on the MCF5307 system bus, and Figure 2-2 illustrates a memory write cycle.

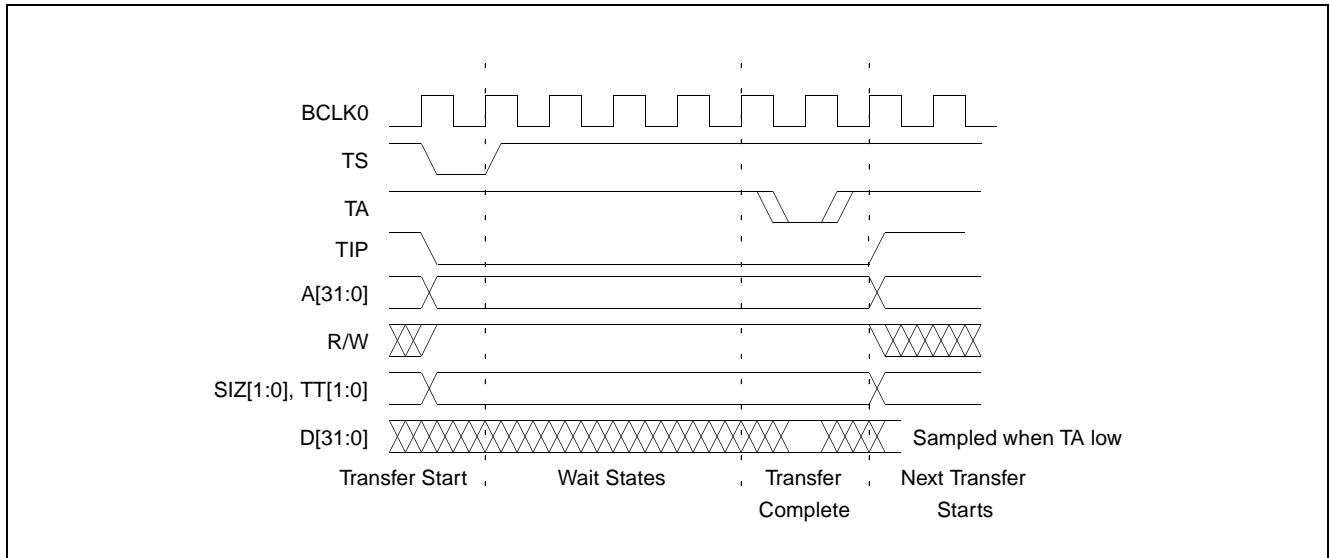

Figure 2-1: MCF5307 Memory Read Cycle

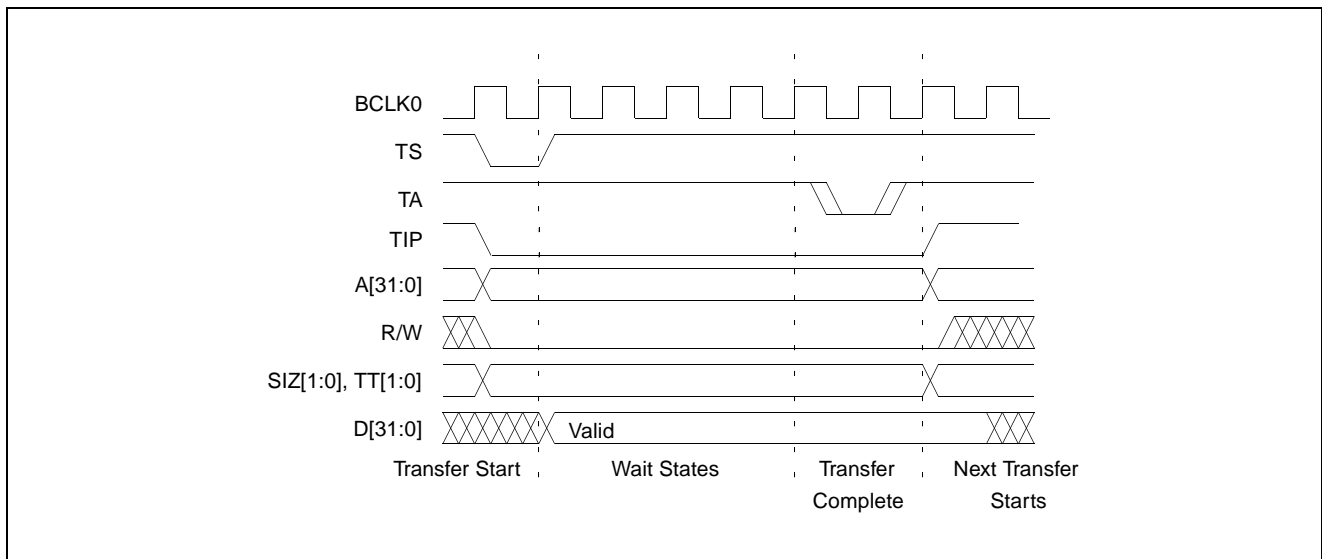

Figure 2-2: MCF5307 Memory Write Cycle

### 2.1.3 Burst Cycles

Burst cycles are very similar to normal cycles, except that they occur as a series of four back-to-back, 32-bit memory reads or writes, with the **TIP** (Transfer In Progress) output asserted continuously through the burst. Burst memory cycles are mainly intended to facilitate cache line fill from program or data memory; they are typically not used for transfers to or from IO peripheral devices such as the SED1375. The MCF5307 chip selects provide a mechanism to disable burst accesses for peripheral devices which are not able to support them.

## 2.2 Chip-Select Module

In addition to generating eight independent chip-select outputs, the MCF5307 Chip Select Module can generate active-low Output Enable (**OE**) and Write Enable (**BWE**) signals compatible with most memory and x86-style peripherals. The MCF5307 bus controller also provides a Read/Write (**R/W**) signal which is compatible with most 68K peripherals.

Chip selects 0 and 1 can be programmed independently to respond to any base address and block size. Chip select 0 can be active immediately after reset, and is typically used to control a boot ROM. Chip select 1 is likewise typically used to control a large static or dynamic RAM block.

Chip selects 2 through 7 have fixed block sizes of 2M bytes each. Each has a unique, fixed offset from a common, programmable starting address. These chip selects are well-suited to typical IO addressing requirements.

Each chip select may be individually programmed for port size (8/16/32 bits), 0 to 15 wait states or external acknowledge, address space type, burst or non-burst cycle support, and write protect.

## 3 SED1375 Bus Interface

This section is a summary of the host bus interface mode used on the SED1375 to interface to the MCF5307.

The SED1375 implements a 16-bit interface to the host microprocessor which may operate in one of several modes compatible with most of the popular embedded microprocessor families. The interface mode used for the MCF5307 is:

- Generic #1 (Chip Select, plus individual Read Enable/Write Enable for each byte).

### 3.1 Host Bus Pin Connection

Table 3-1: Host Bus Interface Pin Mapping

SED1375 Pin Names	Generic #1
AB[15:1]	A[15:1]
AB0	A0
DB[15:0]	D[15:0]
WE1#	WE1#
CS#	External Decode
BCLK	BCLK
BS#	connect to $V_{SS}$
RD/WR#	RD1#
RD#	RD0#
WE0#	WE0#
WAIT#	WAIT#
RESET#	RESET#

For details on configuration, refer to the *SED1375 Hardware Functional Specification*, document number X27A-A-001-xx.

## 3.2 Generic #1 Interface Mode

Generic #1 interface mode is the most general and least processor-specific interface mode on the SED1375. The Generic # 1 interface mode was chosen for this interface due to the simplicity of its timing.

The interface requires the following signals:

- BUSCLK is a clock input which is required by the SED1375 host interface. It is separate from the input clock (CLKI) and is typically driven by the host CPU system clock.
- The address inputs AB0 through AB16, and the data bus DB0 through DB15, connect directly to the CPU address and data bus, respectively. On 32-bit big endian architectures such as the Power PC, the data bus would connect to the high-order data lines; on little endian hosts, or 16-bit big endian hosts, they would connect to the low-order data lines. The hardware engineer must ensure that CNF3 selects the proper endian mode upon reset.
- Chip Select (CS#) is driven by decoding the high-order address lines to select the proper register and memory address space.
- WE0# and WE1# are write enables for the low-order and high-order bytes, respectively, to be driven low when the host CPU is writing data to the SED1375.
- RD# and RD/WR# are read enables for the low-order and high-order bytes, respectively, to be driven low when the host CPU is reading data from the SED1375.
- WAIT# is a signal output from the SED1375 that indicates the host CPU must wait until data is ready (read cycle) or accepted (write cycle) on the host bus. Since host CPU accesses to the SED1375 may occur asynchronously to the display update, it is possible that contention may occur in accessing the SED1375 internal registers and/or refresh memory. The WAIT# line resolves these contentions by forcing the host to wait until the resource arbitration is complete. This signal is active low and may need to be inverted if the host CPU wait state signal is active high.
- The Bus Status (BS#) signal is not used in the bus interface for Generic #1 mode. However, BS# is used to configure the SED1375 for Generic #1 mode and should be tied low (connected to GND).



## 4 MCF5307 To SED1375 Interface

### 4.1 Hardware Description

The SED1375 is interfaced to the MCF5307 with a minimal amount of glue logic. One inverter is required to change the polarity of the WAIT# signal, which is an active low signal to insert wait states in the bus cycle, while the MCF5307's Transfer Acknowledge signal ( $\overline{TA}$ ) is an active low signal to end the current bus cycle. The inverter is enabled by CS# so that  $\overline{TA}$  is not driven by the SED1375 during non-SED1375 bus cycles. A single resistor is used to speed up the rise time of the WAIT# ( $\overline{TA}$ ) signal when terminating the bus cycle.

The following diagram shows a typical implementation of the MCF5307 to SED1375 interface.

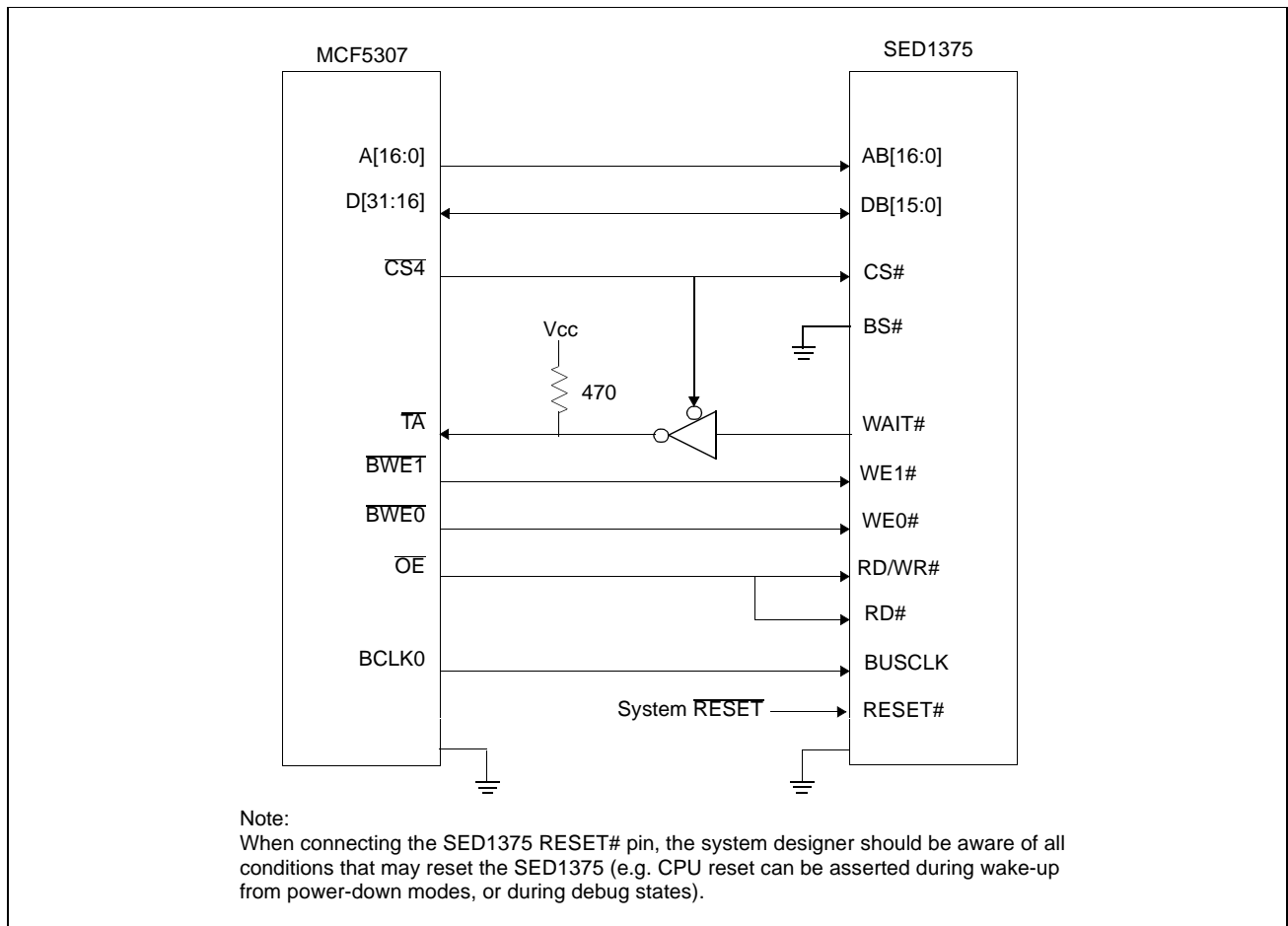

Figure 4-1: Typical Implementation of MCF5307 to SED1375 Interface

## 4.2 SED1375 Hardware Configuration

The SED1375 uses CNF3 through CNF0 and BS# to allow selection of the bus mode and other configuration data on the rising edge of RESET#. Table 4-1: "Summary of Power-On/Reset Options" and Table 4-2: "Host Bus Interface Selection" shows the settings used for the SED1375 in this interface.

*Table 4-1: Summary of Power-On/Reset Options*

SED1375 Pin Name	value on this pin at the rising edge of RESET# is used to configure: (0/1)	
	0	1
CNF0	See "Host Bus Selection" table below	See "Host Bus Selection" table below
CNF1		
CNF2		
CNF3	Little Endian	Big Endian

= configuration for MFC5307 support

*Table 4-2: Host Bus Interface Selection*

CNF2	CNF1	CNF0	BS#	Host Bus Interface
1	1	1	0	Generic #1, 16-bit

= configuration for MFC5307 support

## 4.3 MCF5307 Chip Select Configuration

Chip Selects 0 and 1 have programmable block sizes from 64K bytes through 2G bytes. However, these chip selects would normally be needed to control system RAM and ROM. Therefore, one of the IO chip selects CS2 through CS7 is required to address the entire address space of the SED1375. These IO chip selects have a fixed, 2M byte block size. In the example interface, chip select 4 is used to control the SED1375. The SED1375 only uses a 128K byte block with its 80K byte display buffer residing at the start of this 128K byte block and its internal registers occupying the last 32 bytes of this block. This block of memory will be shadowed over the entire 2M byte space. The CSBAR register should be set to the upper 8 bits of the desired base address.

The following options should be selected in the chip select mask registers (CSMR4/5):

- WP = 0 – disable write protect
- AM = 0 - enable alternate bus master access to the SED1375
- C/I = 1 - disable CPU space access to the SED1375
- SC = 1 - disable Supervisor Code space access to the SED1375
- SD = 0 - enable Supervisor Data space access to the SED1375
- UC = 1 - disable User Code space access to the SED1375
- UD = 0 - enable User Data space access to the SED1375
- V = 1 - global enable (“Valid”) for the chip select

The following options should be selected in the chip select control registers (CSCR4/5):

- WS0-3 = 0 - no internal wait state setting
- AA = 0 - no automatic acknowledgment
- PS (1:0) = 1:0 – memory port size is 16 bits
- BEM = 0 – Byte enable/write enable active on writes only
- BSTR = 0 – disable burst reads
- BSTW = 0 – disable burst writes

## 5 Software

Test utilities and Windows® CE v2.0 display drivers are available for the SED1375. Full source code is available for both the test utilities and the drivers.

The test utilities are configurable for different panel types using a program called 1375CFG, or by directly modifying the source. The Windows CE v2.0 display drivers can be customized by the OEM for different panel types, resolutions and color depths only by modifying the source.

The SED1375 test utilities and Windows CE v2.0 display drivers are available from your sales support contact or on the internet at <http://www.eea.epson.com>.

---

## 6 References

### 6.1 Documents

- Motorola Inc., *MCF5307 ColdFire® Integrated Microprocessor User's Manual*, Motorola Publication no. MCF5307UM/AD; available on the Internet at <http://www.mot.com/SPS/HPESD/prod/coldfire/5307UM.html>.
- Epson Research and Development, Inc., *SED1375 Hardware Functional Specification*; Document Number X27A-A-002-xx.
- Epson Research and Development, Inc., *SDU1375B0C Rev. 1.0 ISA Bus Evaluation Board User Manual*; Document Number X27A-G-005-xx.
- Epson Research and Development, Inc., *SED1375 Programming Notes and Examples*; Document Number X27A-G-002-xx.

### 6.2 Document Sources

- Motorola Inc.: Motorola Literature Distribution Center, (800) 441-2447.
- Motorola website: <http://www.mot.com>.
- Epson Electronics America website: <http://www.eea.epson.com>

## 7 Technical Support

### 7.1 EPSON LCD Controllers (SED1375)

**Japan**

Seiko Epson Corporation  
Electronic Devices Marketing Division  
421-8, Hino, Hino-shi  
Tokyo 191-8501, Japan  
Tel: 042-587-5812  
Fax: 042-587-5564  
<http://www.epson.co.jp>

**North America**

Epson Electronics America, Inc.  
150 River Oaks Parkway  
San Jose, CA 95134, USA  
Tel: (408) 922-0200  
Fax: (408) 922-0238  
<http://www.eea.epson.com>

**Taiwan, R.O.C.**

Epson Taiwan Technology  
& Trading Ltd.  
10F, No. 287  
Nanking East Road  
Sec. 3, Taipei, Taiwan, R.O.C.  
Tel: 02-2717-7360  
Fax: 02-2712-9164

**Hong Kong**

Epson Hong Kong Ltd.  
20/F., Harbour Centre  
25 Harbour Road  
Wanchai, Hong Kong  
Tel: 2585-4600  
Fax: 2827-4346

**Europe**

Epson Europe Electronics GmbH  
Riesstrasse 15  
80992 Munich, Germany  
Tel: 089-14005-0  
Fax: 089-14005-110

**Singapore**

Epson Singapore Pte., Ltd.  
No. 1  
Temasek Avenue #36-00  
Millenia Tower  
Singapore, 039192  
Tel: 337-7911  
Fax: 334-2716

### 7.2 Motorola MCF5307 Processor

- Motorola Design Line, (800) 521-6274.
- Local Motorola sales office or authorized distributor.

# EPSON®



## SED1375 Embedded Memory LCD Controller

# Interfacing to the Philips MIPS PR31500/PR31700 Processor

Document Number: X27A-G-012-01

Copyright © 1999 Epson Research and Development, Inc. All Rights Reserved.

Information in this document is subject to change without notice. You may download and use this document, but only for your own use in evaluating Seiko Epson/EPSON products. You may not modify the document. Epson Research and Development, Inc. disclaims any representation that the contents of this document are accurate or current. The Programs/Technologies described in this document may contain material protected under U.S. and/or International Patent laws.

EPSON is a registered trademark of Seiko Epson Corporation. All other trademarks are the property of their respective owners.

---

**THIS PAGE LEFT BLANK**



# Table of Contents

<b>1</b>	<b>Introduction</b>	<b>7</b>
<b>2</b>	<b>Interfacing to the PR31500/PR31700</b>	<b>8</b>
<b>3</b>	<b>SED1375 Host Bus Interface</b>	<b>9</b>
3.1	Host Bus Pin Connection	9
3.2	Generic #1 Interface Mode	10
3.3	Generic #2 Interface Mode	11
<b>4</b>	<b>Direct Connection to the Philips PR31500/PR31700</b>	<b>12</b>
4.1	General Description	12
4.2	Memory Mapping and Aliasing	13
4.3	SED1375 Configuration and Pin Mapping	14
<b>5</b>	<b>Using the ITE IT8368E PC Card Buffer</b>	<b>15</b>
5.1	Hardware Description	15
5.2	IT8368E Configuration	17
5.3	Memory Mapping and Aliasing	17
5.4	SED1375 Configuration	18
<b>6</b>	<b>Software</b>	<b>19</b>
<b>7</b>	<b>Technical Support</b>	<b>20</b>
7.1	EPSON LCD Controllers (SED1375)	20
7.2	Philips MIPS PR31500/PR31700 Processor	20
7.3	ITE IT8368E	20

**THIS PAGE LEFT BLANK**

---

## List of Tables

Table 3-1: Host Bus Interface Pin Mapping . . . . .	9
Table 4-1: SED1375 Configuration for Direct Connection . . . . .	14
Table 5-1: PR31500/PR31700 to PC Card Slots Address Mapping With and Without the IT8368E. . . . .	17
Table 5-2: SED1375 Configuration Using the IT8368E. . . . .	18

## List of Figures

Figure 4-1: SED1375 to PR31500/PR31700 Direct Connection . . . . .	12
Figure 5-1: SED1375 to PR31500/PR31700 Connection Using an IT8368E . . . . .	16

**THIS PAGE LEFT BLANK**

---

# 1 Introduction

This application note describes the hardware required to interface the SED1375 Embedded Memory LCD Controller and the Philips MIPS PR31500/PR31700 Processor. The pairing of these two devices results in an embedded system offering impressive display capability with very low power consumption.

The designs described in this document are presented only as examples of how such interfaces might be implemented. This application note will be updated as appropriate. Please check the Epson Electronics America website at <http://www.eea.epson.com> for the latest revision of this document before beginning any development.

We appreciate your comments on our documentation. Please contact us via email at [techpubs@erd.epson.com](mailto:techpubs@erd.epson.com).

## 2 Interfacing to the PR31500/PR31700

The Philips MIPS PR31500/PR31700 processor supports up to two PC Card (PCMCIA) slots. It is through this host bus interface that the SED1375 connects to the PR31500/PR31700 processor.

The SED1375 can be successfully interfaced using one of two configurations:

- Direct connection to PR31500/PR31700 (see Section 4, *Direct Connection to the Philips PR31500/PR31700* on page 12).
- System design using one ITE IT8368E PC Card/GPIO buffer chip (see Section 5, *Using the ITE IT8368E PC Card Buffer* on page 15).

## 3 SED1375 Host Bus Interface

This section is a summary of the host bus interface modes available on the SED1375 that would be used to interface to the PR31500/PR31700.

The SED1375 implements a 16-bit interface to the host microprocessor which may operate in one of several modes compatible with most of the popular embedded microprocessor families. The interface modes used for the PR31500/PR31700 are:

- Generic #1 (Chip Select, plus individual Read Enable/Write Enable for each byte).
- Generic #2 (External Chip Select, shared Read/Write Enable for high byte, individual Read/Write Enable for low byte).

### 3.1 Host Bus Pin Connection

The following table shows the functions of each host bus interface signal.

*Table 3-1: Host Bus Interface Pin Mapping*

SED1375 Pin Names	Generic #1	Generic #2
AB[15:1]	A[15:1]	A[15:1]
AB0	A0	A0
DB[15:0]	D[15:0]	D[15:0]
WE1#	WE1#	BHE#
CS#	External Decode	External Decode
BCLK	BCLK	BCLK
BS#	connect to $V_{SS}$	connect to IO $V_{DD}$
RD/WR#	RD1#	connect to IO $V_{DD}$
RD#	RD0#	RD#
WE0#	WE0#	WE#
WAIT#	WAIT#	WAIT#
RESET#	RESET#	RESET#

For details on configuration, refer to the *SED1375 Hardware Functional Specification*, document number X27A-A-001-xx.

## 3.2 Generic #1 Interface Mode

Generic #1 interface mode is the most general and least processor-specific interface mode on the SED1375. The Generic # 1 interface mode was chosen for this interface due to the simplicity of its timing.

The interface requires the following signals:

- BUSCLK is a clock input which is required by the SED1375 host interface. It is separate from the input clock (CLKI) and is typically driven by the host CPU system clock.
- The address inputs AB0 through AB16, and the data bus DB0 through DB15, connect directly to the CPU address and data bus, respectively. On 32-bit big endian architectures such as the Power PC, the data bus would connect to the high-order data lines; on little endian hosts, or 16-bit big endian hosts, they would connect to the low-order data lines. The hardware engineer must ensure that CNF3 selects the proper endian mode upon reset.
- Chip Select (CS#) is driven by decoding the high-order address lines to select the proper register and memory address space.
- WE0# and WE1# are write enables for the low-order and high-order bytes, respectively, to be driven low when the host CPU is writing data to the SED1375. These signals must be generated by external hardware based on the control outputs from the host CPU.
- RD# and RD/WR# are read enables for the low-order and high-order bytes, respectively, to be driven low when the host CPU is reading data from the SED1375. These signals must be generated by external hardware based on the control outputs from the host CPU.
- WAIT# is a signal output from the SED1375 that indicates the host CPU must wait until data is ready (read cycle) or accepted (write cycle) on the host bus. Since host CPU accesses to the SED1375 may occur asynchronously to the display update, it is possible that contention may occur in accessing the SED1375 internal registers and/or refresh memory. The WAIT# line resolves these contentions by forcing the host to wait until the resource arbitration is complete. This signal is active low and may need to be inverted if the host CPU wait state signal is active high.
- The Bus Status (BS#) signal is not used in the bus interface for Generic #1 mode. However, BS# is used to configure the SED1375 for Generic #1 mode and should be tied low (connected to GND).



### 3.3 Generic #2 Interface Mode

Generic #2 interface mode is a general and non-processor-specific interface mode on the SED1375. The Generic # 2 interface mode was chosen for this interface due to the simplicity of its timing and compatibility with the PR31500/PR31700 control signals.

The interface requires the following signals:

- BUSCLK is a clock input which synchronizes transfers between the host CPU and the SED1375. It is separate from the input clock (CLKI) and is typically driven by the host CPU system clock.
- The address inputs AB0 through AB16, and the data bus DB0 through DB15, connect directly to the CPU address and data bus, respectively. On 32-bit big endian architectures such as the Power PC, the data bus would connect to the high-order data lines; on little endian hosts, or 16-bit big endian hosts, they would connect to the low-order data lines. The hardware engineer must ensure that CNF3 selects the proper endian mode upon reset.
- Chip Select (CS#) is driven by decoding the high-order address lines to select the proper register and memory address space.
- WE1# is the high byte enable for both read and write cycles.
- WE0# is the write enable signal for the SED1375, to be driven low when the host CPU is writing data from the SED1375.
- RD# is the read enable for the SED1375, to be driven low when the host CPU is reading data from the SED1375.
- WAIT# is a signal which is output from the SED1375 to the host CPU that indicates when data is ready (read cycle) or accepted (write cycle) on the host bus. Since host CPU accesses to the SED1375 may occur asynchronously to the display update, it is possible that contention may occur in accessing the 1375 internal registers and/or refresh memory. The WAIT# line resolves these contentions by forcing the host to wait until the resource arbitration is complete. This signal is active low and may need to be inverted if the host CPU wait state signal is active high.
- The Bus Status (BS#) and Read/Write (RD/WR#) signals are not used in the bus interface for Generic #2 mode. However, BS# is used to configure the SED1375 for Generic #2 mode and should be tied high (connected to IO  $V_{DD}$ ). RD/WR# should also be tied high.

## 4 Direct Connection to the Philips PR31500/PR31700

### 4.1 General Description

In this example implementation the SED1375 occupies the PR31500/PR31700 PC Card slot #1.

The SED1375 is easily interfaced to the PR31500/PR31700 with minimal additional logic. The address bus of the PR31500/PR31700 PC Card interface is multiplexed and must be demultiplexed using an advanced CMOS latch (e.g., 74AHC373). The direct connection approach makes use of the SED1375 in its “Generic #2” interface configuration.

The following diagram demonstrates a typical implementation of the interface.

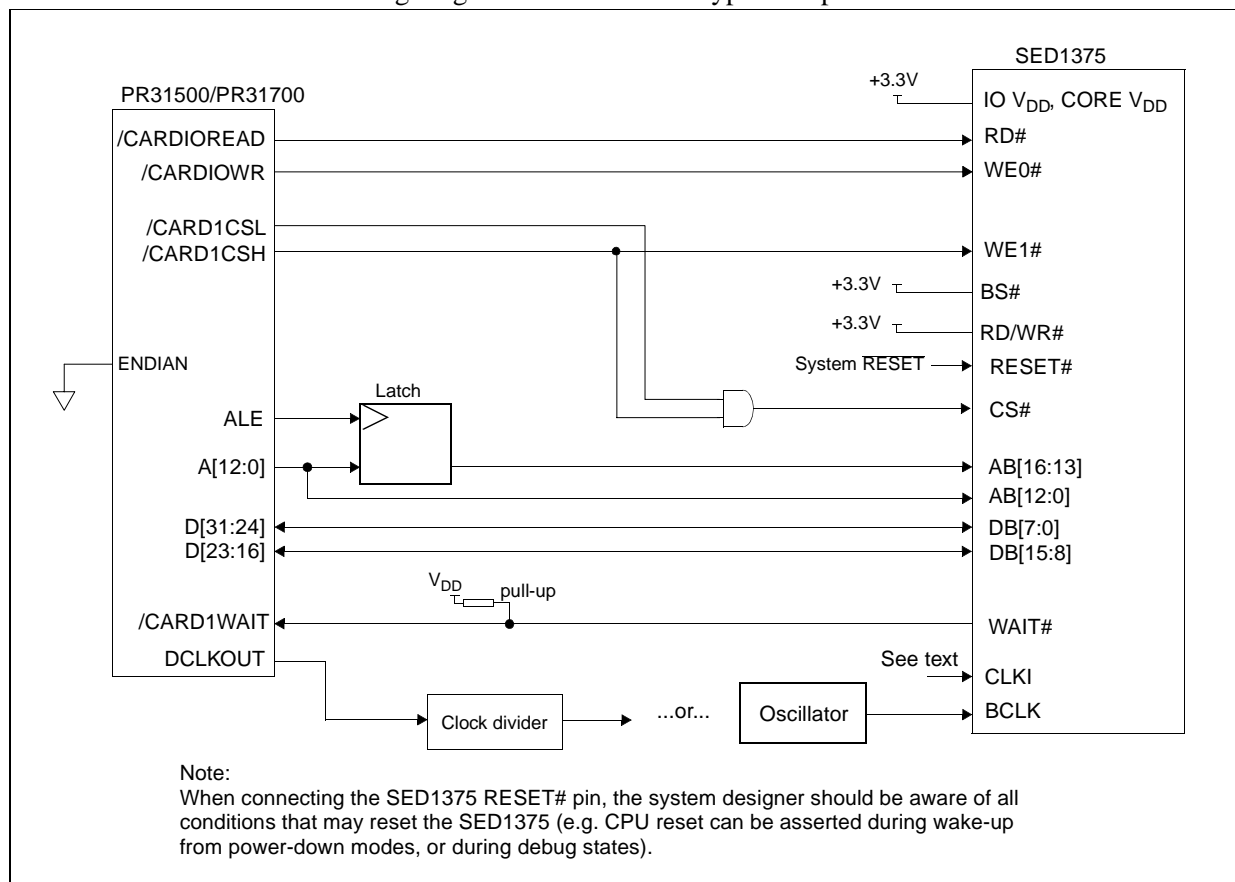

Figure 4-1: SED1375 to PR31500/PR31700 Direct Connection

#### Note

See Section 3.1 on page 9 and Section 3.3 on page 11 for Generic #2 pin descriptions.

The “Generic #2” host interface control signals of the SED1375 are asynchronous with respect to the SED1375 bus clock. This gives the system designer full flexibility to choose the appropriate source (or sources) for CLKI and BCLK. The choice of whether both clocks should be the same, and whether to use DCLKOUT (divided) as clock source, should be based on the desired:

- pixel and frame rates.
- power budget.
- part count.
- maximum SED1375 clock frequencies.

The SED1375 also has internal clock dividers providing additional flexibility.

## 4.2 Memory Mapping and Aliasing

The SED1375 requires an addressing space of 128K bytes. The on-chip display memory occupies the range 0 through 13FFFh. The registers occupy the range 1FFE0h through 1FFFFh. The PR31500/PR31700 demultiplexed address lines A17 and above are ignored, thus the SED1375 is aliased 512 times at 128K byte intervals over the 64M byte PC Card slot #1 memory space. In this example implementation, the PR31500/PR31700 control signal /CARDREG is ignored; therefore the SED1375 also takes up the entire PC Card slot 1 configuration space.

### Note

If aliasing is undesirable, additional decoding circuitry must be added.

## 4.3 SED1375 Configuration and Pin Mapping

The SED1375 is configured at power up by latching the state of the CNF[3:0] pins. Pin BS# also plays a role in host bus interface configuration. For details on configuration, refer to the *SED1375 Hardware Functional Specification*, document number X27A-A-001-xx.

The table below shows those configuration settings relevant to the direct connection approach.

*Table 4-1: SED1375 Configuration for Direct Connection*

SED1375 Configuration Pin	Value hard wired on this pin is used to configure:	
	1 (IO V <sub>DD</sub> )	0 (V <sub>SS</sub> )
BS#	Generic #2	Generic #1
CNF3	Big Endian	Little Endian
CNF[2:0]	111: Generic #1 or #2	

= configuration for Philips PR31500/PR31700 host bus interface

## 5 Using the ITE IT8368E PC Card Buffer

If the system designer uses the ITE IT8368E PC Card and multiple-function I/O buffer, the SED1375 can be interfaced so that it “shares” a PC Card slot. The SED1375 is mapped to a rarely-used 16M byte portion of the PC Card slot buffered by the IT8368E. This makes the SED1375 virtually transparent to PC Card devices that use the same slot.

### 5.1 Hardware Description

The ITE8368E has been specially designed to support EPSON LCD controllers. The ITE IT8368E provides eleven Multi-Function IO pins (MFIO). Configuration registers may be used to allow these MFIO pins to provide the control signals required to implement the SED1375 CPU interface.

The PR31500/PR31700 processor only provides addresses A[12:0]; therefore devices requiring more address space must use an external device to latch A[25:13]. The IT8368E's MFIO pins can be configured to provide this latched address.

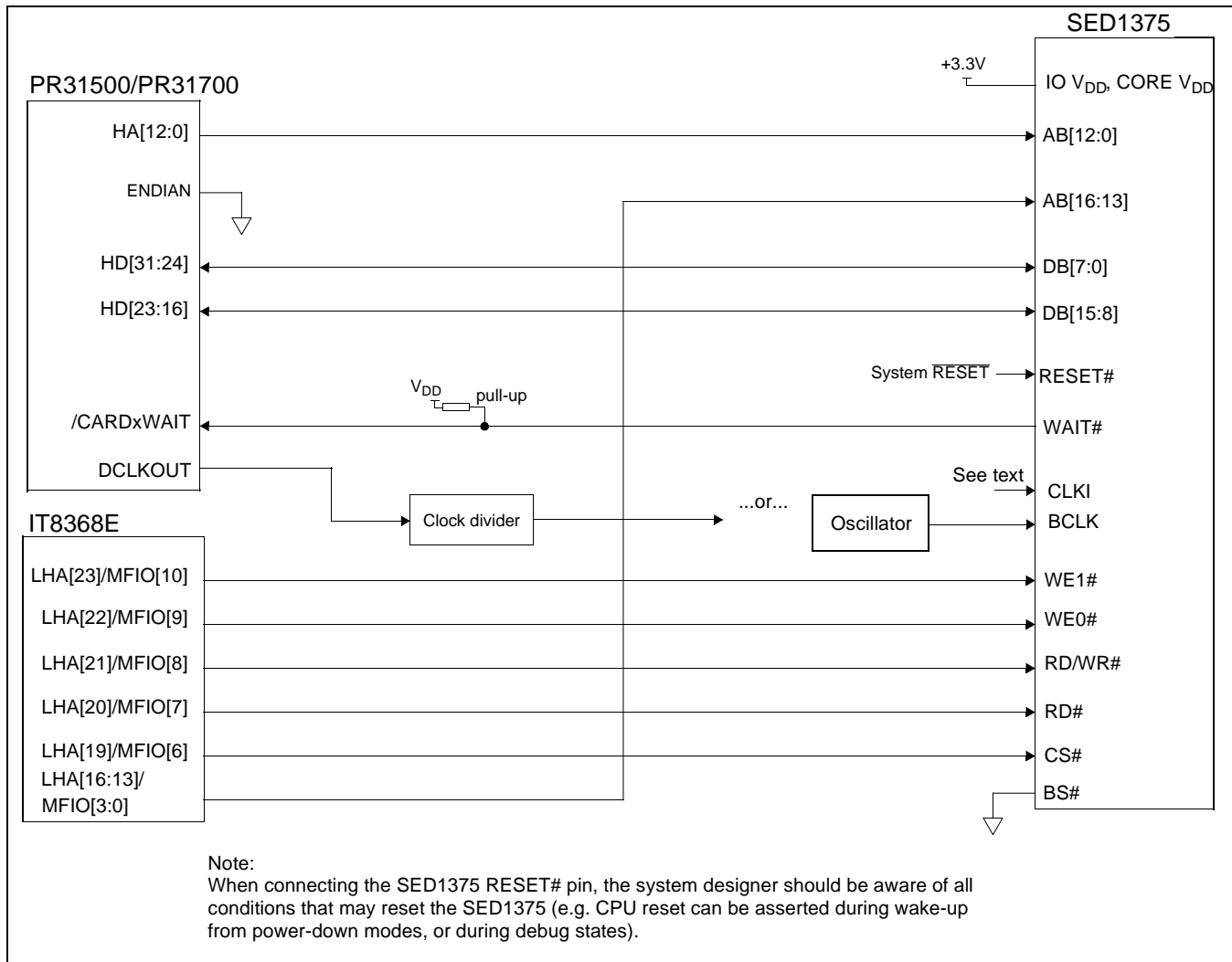

Figure 5-1: SED1375 to PR31500/PR31700 Connection Using an IT8368E

#### Note

See Section 3.1 on page 9 and Section 3.2 on page 10 for Generic #1 pin descriptions.

The “Generic #1” host interface control signals of the SED1375 are asynchronous with respect to the SED1375 bus clock. This gives the system designer full flexibility to choose the appropriate source (or sources) for CLKI and BCLK. The choice of whether both clocks should be the same, and whether to use DCLKOUT (divided) as clock source, should be based on the desired:

- pixel and frame rates.
- power budget.
- part count.
- maximum SED1375 clock frequencies.

The SED1375 also has internal clock dividers providing additional flexibility.

## 5.2 IT8368E Configuration

The IT8368E provides eleven multi-function IO pins (MFIO). The IT8368E must have both “Fix Attribute/IO” and “VGA” modes on. When both these modes are enabled, the MFIO pins provide control signals needed by the SED1375 host bus interface, and a 16M byte portion of the system PC Card attribute and IO space is allocated to address the SED1375. When accessing the SED1375 the associated card-side signals are disabled in order to avoid any conflicts.

For mapping details, refer to section 3.3: “Memory Mapping and Aliasing.” For connection details see Figure 5-1: “*SED1375 to PR31500/PR31700 Connection Using an IT8368E,*” on page 16. For further information on the IT8368E, refer to the *IT8368E PC Card/GPIO Buffer Chip Specification*.

### Note

When a second IT8368E is used, that circuit should not be set in VGA mode.

## 5.3 Memory Mapping and Aliasing

When the PR31500/PR31700 accesses the PC Card slots *without* the ITE IT8368E, its system memory is mapped as in Table 5-1: *PR31500/PR31700 to PC Card Slots Address Mapping With and Without the IT8368E*.

### Note

Bit CARD1IOEN or CARD2IOEN, depending on which card slot is used, must to be set to 0 in the PR31500/PR31700 Memory Configuration Register 3.

When the PR31500/PR31700 accesses the PC Card slots buffered through the ITE IT8368E, bits CARD1IOEN and CARD2IOEN are ignored and the attribute/IO space of the PR31500/PR31700 is divided into Attribute, I/O and SED1375 access. Table 5-1: *PR31500/PR31700 to PC Card Slots Address Mapping With and Without the IT8368E* provides all details of the Attribute/IO address reallocation by the IT8368E.

Table 5-1: *PR31500/PR31700 to PC Card Slots Address Mapping With and Without the IT8368E*

PC Card Slot #	TX3912 Address	Size	Using the ITE IT8368E	Direct Connection, CARDnIOEN=0	Direct Connection, CARDnIOEN=1
1	0800 0000h	16M byte	Card 1 IO	SED1375 (aliased 512 times at 128K byte intervals)	Card 1 IO
	0900 0000h	16M byte	SED1375 (aliased 128 times at 128K byte intervals)		
	0A00 0000h	32M byte	Card 1 Attribute		
	6400 0000h	64M byte	Card 1 Memory		
				SED1375 (aliased 512 times at 128K byte intervals)	
2	0C00 0000h	16M byte	Card 2 IO	SED1375 (aliased 512 times at 128K byte intervals)	Card 2 IO
	0D00 0000h	16M byte	SED1375 (aliased 128 times at 128K byte intervals)		
	0E00 0000h	32M byte	Card 2 Attribute		
	6800 0000h	64M byte	Card 2 Memory		
				SED1375 (aliased 512 times at 128K byte intervals)	

## 5.4 SED1375 Configuration

The SED1375 is configured at power up by latching the state of the CNF[3:0] pins. Pin BS# also plays a role in host bus interface configuration. For details on configuration, refer to the *SED1375 Hardware Functional Specification*, document number X27A-A-001-xx.

The table below shows those configuration settings relevant to this specific interface.

*Table 5-2: SED1375 Configuration Using the IT8368E*

SED1375 Configuration Pin	Value hard wired on this pin is used to configure:	
	1 (IO V <sub>DD</sub> )	0 (V <sub>SS</sub> )
BS#	Generic #2	Generic #1
CNF3	Big Endian	Little Endian
CNF[2:0]	111: Generic #1 or #2	

= configuration for connection using ITE IT8368E



---

## 6 Software

Test utilities and Windows® CE v2.0 display drivers are available for the SED1375. Full source code is available for both the test utilities and the drivers.

The test utilities are configurable for different panel types using a program called 1357CFG, or by directly modifying the source. The Windows CE v2.0 display drivers can be customized by the OEM for different panel types, resolutions and color depths only by modifying the source.

The SED1375 test utilities and Windows CE v2.0 display drivers are available from your sales support contact or [www.eea.epson.com](http://www.eea.epson.com).

## 7 Technical Support

### 7.1 EPSON LCD Controllers (SED1375)

**Japan**

Seiko Epson Corporation  
Electronic Devices Marketing Division  
421-8, Hino, Hino-shi  
Tokyo 191-8501, Japan  
Tel: 042-587-5812  
Fax: 042-587-5564

**North America**

Epson Electronics America, Inc.  
150 River Oaks Parkway  
San Jose, CA 95134, USA  
Tel: (408) 922-0200  
Fax: (408) 922-0238  
<http://www.eea.epson.com>

**Taiwan, R.O.C.**

Epson Taiwan Technology  
& Trading Ltd.  
10F, No. 287  
Nanking East Road  
Sec. 3, Taipei, Taiwan, R.O.C.  
Tel: 02-2717-7360  
Fax: 02-2712-9164

**Europe**

Epson Europe Electronics GmbH  
Riesstrasse 15  
80992 Munich, Germany  
Tel: 089-14005-0  
Fax: 089-14005-110

**Hong Kong**

Epson Hong Kong Ltd.  
20/F., Harbour Centre  
25 Harbour Road  
Wanchai, Hong Kong  
Tel: 2585-4600  
Fax: 2827-4346

**Singapore**

Epson Singapore Pte., Ltd.  
No. 1  
Temasek Avenue #36-00  
Millenia Tower  
Singapore, 039192  
Tel: 337-7911  
Fax: 334-2716

### 7.2 Philips MIPS PR31500/PR31700 Processor

**Philips Semiconductors**

Handheld Computing Group  
4811 E. Arques Avenue  
M/S 42, P.O. Box 3409  
Sunnyvale, CA 94088-3409  
Tel: (408) 991-2313  
<http://www.philips.com>

### 7.3 ITE IT8368E

**Integrated Technology Express, Inc.**

Sales & Marketing Division  
2710 Walsh Avenue  
Santa Clara, CA 95051, USA  
Tel: (408) 980-8168  
Fax: (408) 980-9232  
<http://www.iteusa.com>

# EPSON®



## SED1375 Embedded Memory LCD Controller

# Interfacing to the NEC VR4181A™ Microprocessor

Document Number: X27A-G-013-01

Copyright © 1999 Epson Research and Development, Inc. All Rights Reserved.

Information in this document is subject to change without notice. You may download and use this document, but only for your own use in evaluating Seiko Epson/EPSON products. You may not modify the document. Epson Research and Development, Inc. disclaims any representation that the contents of this document are accurate or current. The Programs/Technologies described in this document may contain material protected under U.S. and/or International Patent laws.

EPSON is a registered trademark of Seiko Epson Corporation. All Trademarks are the property of their respective owners.

---

**THIS PAGE LEFT BLANK**

# Table of Contents

<b>1</b>	<b>Introduction</b>	<b>7</b>
<b>2</b>	<b>Interfacing to the NEC VR4181A</b>	<b>8</b>
2.1	The NEC VR4181A System Bus	8
2.1.1	Overview	8
2.1.2	LCD Memory Access Signals	9
<b>3</b>	<b>SED1375 Host Bus Interface</b>	<b>10</b>
3.1	Host Bus Pin Connection	10
3.2	Generic #2 Interface Mode	11
<b>4</b>	<b>VR4181A to SED1375 Interface</b>	<b>12</b>
4.1	Hardware Description	12
4.2	SED1375 Hardware Configuration	13
4.3	NEC VR4181A Configuration	14
<b>5</b>	<b>Software</b>	<b>15</b>
<b>6</b>	<b>References</b>	<b>16</b>
6.1	Documents	16
6.2	Document Sources	16
<b>7</b>	<b>Technical Support</b>	<b>17</b>
7.1	Epson LCD Controllers (SED1375)	17
7.2	NEC Electronics Inc.	17

**THIS PAGE LEFT BLANK**

---

## List of Tables

Table 3-1: Host Bus Interface Pin Mapping . . . . .	10
Table 4-1: Summary of Power-On/Reset Options . . . . .	13
Table 4-2: Host Bus Selection . . . . .	13

## List of Figures

Figure 4-1: Typical Implementation of VR4181A to SED1375 Interface . . . . .	12
--	----

**THIS PAGE LEFT BLANK**



---

# 1 Introduction

This application note describes the hardware required to interface the SED1375 Embedded Memory LCD Controller and the NEC VR4181A microprocessor. The NEC VR4181A microprocessor is specifically designed to support an external LCD controller and the pairing of these two devices results in an embedded system offering impressive display capability with very low power consumption.

The designs described in this document are presented only as examples of how such interfaces might be implemented. This application note will be updated as appropriate. Please check the Epson Electronics America website at <http://www.eea.epson.com> for the latest revision of this document before beginning any development.

We appreciate your comments on our documentation. Please contact us via email at [techpubs@erd.epson.com](mailto:techpubs@erd.epson.com).

## 2 Interfacing to the NEC VR4181A

### 2.1 The NEC VR4181A System Bus

The VR-Series family of microprocessors features a high-speed synchronous system bus typical of modern microprocessors. Designed with external LCD controller support and Windows CE based embedded consumer applications in mind, the VR4181A offers a highly integrated solution for portable systems. This section is an overview of the operation of the CPU bus to establish interface requirements.

#### 2.1.1 Overview

The NEC VR4181A is designed around the RISC architecture developed by MIPS. This microprocessor is designed around the 100MHz VR4110 CPU core which supports the MIPS III and MIPS16 instruction sets. The CPU communicates with external devices via an ISA interface.

The NEC VR4181A has direct support for an external LCD controller. A 64 to 512-kilobyte block of memory is assigned to the LCD controller with a dedicated chip select signal. Word or byte accesses are controlled by the system high byte signal, #UBE.

## 2.1.2 LCD Memory Access Signals

The SED1375 requires an addressing range of 128Kbytes. When the VR4181A's external LCD controller chip select signal is programmed to a window of that size, the SED1375 must reside in the VR4181A physical address range of 133E 0000h to 133F FFFFh which is part of the external ISA memory space.

The signals required for external LCD controller access are listed below and obey ISA signalling rules.

- A[16:0]                      Address bus
- #UBE                        High byte enable (active low)
- #LCDCS                    LCD controller (SED1375) chip select (active low)
- D[15:0]                    Data bus
- #MEMRD                  Read command (active low)
- #MEMWR                  Write command (active low)
- #MEMCS16                Sixteen-bit peripheral capability acknowledge (active low)
- IORDY                     Ready signal from SED1375
- SYSCLK                    Optional, prescalable bus clock

Once an address in the LCD block of memory is accessed, the LCD chip select #LCDCS is driven low. The read or write enable signals, #MEMRD or #MEMWR, are driven low for the appropriate cycle and IORDY is driven low by the SED1375 to insert wait states into the cycle. The high byte enable is driven low for 16-bit transfers and high for 8-bit transfers.

### 3 SED1375 Host Bus Interface

This section is a summary of the host bus interface modes available on the SED1375 that would be used to interface to the VR4181A.

The SED1375 implements a 16-bit interface to the host microprocessor which may operate in one of several modes compatible with most of the popular embedded microprocessor families. The interface mode used for the VR4181A is:

- Generic #2 (External Chip Select, shared Read/Write Enable for high byte, individual Read/Write Enable for low byte).

#### 3.1 Host Bus Pin Connection

Table 3-1: Host Bus Interface Pin Mapping

SED1375 Pin Names	Generic #2
AB[16:1]	A[16:1]
AB0	A0
DB[15:0]	D[15:0]
WE1#	BHE#
CS#	External Decode
BCLK	BCLK
BS#	Connect to IO V <sub>DD</sub>
RD/WR#	Connect to IO V <sub>DD</sub>
RD#	RD#
WE0#	WE#
WAIT#	WAIT#
RESET#	RESET#

For details on configuration, refer to the *SED1375 Hardware Functional Specification*, document number X27A-A-001-xx.

## 3.2 Generic #2 Interface Mode

Generic #2 interface mode is a general and non-processor-specific interface mode on the SED1375. The Generic # 2 interface mode was chosen for this interface due to the simplicity of its timing and compatibility with the VR4181A control signals.

The interface requires the following signals:

- BUSCLK is a clock input which synchronizes transfers between the host CPU and the SED1375. It is separate from the input clock (CLKI) and is typically driven by the host CPU system clock.
- The address inputs AB0 through AB16, and the data bus DB0 through DB15, connect directly to the CPU address and data bus, respectively. On 32-bit big endian architectures such as the Power PC, the data bus would connect to the high-order data lines; on little endian hosts, or 16-bit big endian hosts, they would connect to the low-order data lines. The hardware engineer must ensure that CNF3 selects the proper endian mode upon reset.
- Chip Select (CS#) is driven by decoding the high-order address lines to select the proper register and memory address space.
- WE1# is the high byte enable for both read and write cycles.
- WE0# is the write enable signal for the SED1375, to be driven low when the host CPU is writing data from the SED1375.
- RD# is the read enable for the SED1375, to be driven low when the host CPU is reading data from the SED1375.
- WAIT# is a signal which is output from the SED1375 to the host CPU that indicates when data is ready (read cycle) or accepted (write cycle) on the host bus. Since host CPU accesses to the SED1375 may occur asynchronously to the display update, it is possible that contention may occur in accessing the SED1375 internal registers or memory. The WAIT# line resolves these contentions by forcing the host to wait until the resource arbitration is complete. This signal is active low and may need to be inverted if the host CPU wait state signal is active high.
- The Bus Status (BS#) and Read/Write (RD/WR#) signals are not used in the bus interface for Generic #2 mode. However, BS# is used to configure the SED1375 for Generic #2 mode and should be tied high (connected to IOV<sub>DD</sub>). RD/WR# should also be tied high.

## 4 VR4181A to SED1375 Interface

### 4.1 Hardware Description

The NEC VR4181A microprocessor is specifically designed to support an external LCD controller by providing the internal address decoding and control signals necessary. By using the Generic # 2 interface, a glueless interface is achieved. The diagram below shows a typical implementation of the VR4181A to SED1375 interface.

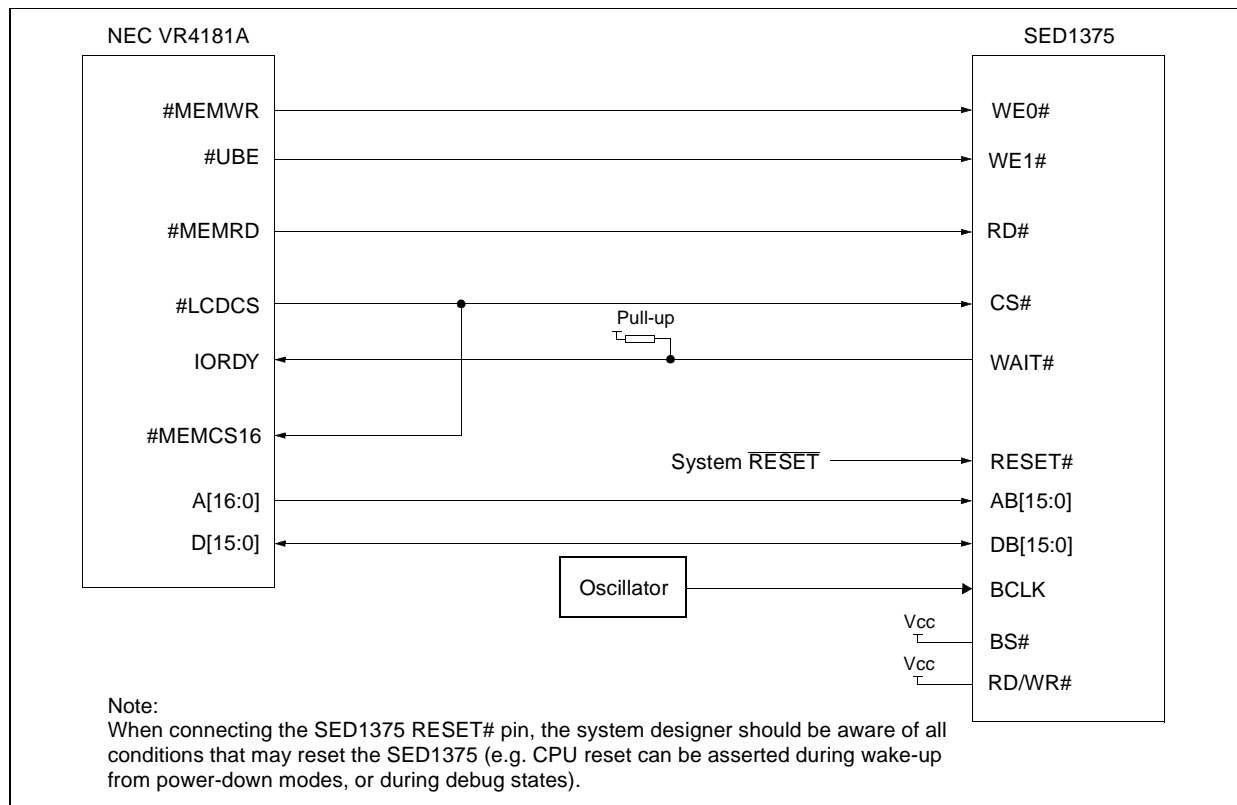

Figure 4-1: Typical Implementation of VR4181A to SED1375 Interface

The host interface control signals of the SED1375 are asynchronous with respect to the SED1375 bus clock. This gives the system designer full flexibility to choose the appropriate source (or sources) for CLKI and BCLK. The choice of whether both clocks should be the same, and whether an external or internal clock divider is needed, should be based on the desired:

- pixel and frame rates.
- power budget.
- part count.
- maximum SED1375 clock frequencies.

The SED1375 also has internal clock dividers providing additional flexibility.

## 4.2 SED1375 Hardware Configuration

The SED1375 uses CNF3 through CNF0 and BS# to allow selection of the bus mode and other configuration data on the rising edge of RESET#. Refer to the *SED1375 Hardware Functional Specification*, document number X27A-A-001-xx for details.

The tables below show those configuration settings important to the Generic #2 host bus interface.

*Table 4-1: Summary of Power-On/Reset Options*

Signal	value on this pin at the rising edge of RESET# is used to configure: (0/1)	
	0	1
CNF0	See "Host Bus Selection" table below	See "Host Bus Selection" table below
CNF1		
CNF2		
CNF3	Little Endian	Big Endian

= configuration for NEC VR4181A support

*Table 4-2: Host Bus Selection*

CNF2	CNF1	CNF0	BS#	Host Bus Interface
1	1	1	1	Generic #2, 16-bit

= configuration for NEC VR4181A support

## 4.3 NEC VR4181A Configuration

The NEC VR4181A must be configured through its internal registers in order to map the SED1375 to the external LCD controller space. The following register values must be set.

Register LCDGPMD at address 0B00 032Eh must be set as follows.

- Bit 7 must be set to 1 to disable the internal LCD controller and enable the external LCD controller interface. This also maps pin SHCLK to #LCDCS and pin LOCLK to #MEMCS16.
- Bits [1:0] must be set to 01b to reserve 128Kbytes of memory address range 133E 0000h to 133F FFFFh for the external LCD controller.

Register GPMD2REG at address 0B00 0304h must be set as follows.

- Bits [9:8] (GP20MD[1:0]) must be set to 11b to map pin GPIO20 to #UBE.
- Bits [5:4] (GP18MD[1:0]) must be set to 01b to map pin GPIO18 to IORDY.



---

## 5 Software

Test utilities and Windows® CE v2.0 display drivers are available for the SED1375. Full source code is available for both the test utilities and the drivers.

The test utilities are configurable for different panel types using a program called 1375CFG, or by directly modifying the source. The Windows CE v2.0 display drivers can be customized by the OEM for different panel types, resolutions and color depths only by modifying the source.

The SED1375 test utilities and Windows CE v2.0 display drivers are available from your sales support contact or on the internet at <http://www.eea.epson.com>.

## 6 References

### 6.1 Documents

- NEC VR4181A Target Specification, Revision 0.5, 9/11/98
- Epson Research and Development, Inc., *SED1375 Hardware Functional Specification*; Document Number X27A-A-002-xx.
- Epson Research and Development, Inc., *SDU1375B0C Rev. 1.0 ISA Bus Evaluation Board User Manual*; Document Number X27A-G-005-xx.
- Epson Research and Development, Inc., *SED1375 Programming Notes and Examples*; Document Number X27A-G-002-xx.

### 6.2 Document Sources

- NEC website at <http://www.nec.com>.
- Epson Electronics America website at <http://www.eea.epson.com>

## 7 Technical Support

### 7.1 Epson LCD Controllers (SED1375)

#### Japan

Seiko Epson Corporation  
Electronic Devices Marketing Division  
421-8, Hino, Hino-shi  
Tokyo 191-8501, Japan  
Tel: 042-587-5812  
Fax: 042-587-5564  
<http://www.epson.co.jp>

#### North America

Epson Electronics America, Inc.  
150 River Oaks Parkway  
San Jose, CA 95134, USA  
Tel: (408) 922-0200  
Fax: (408) 922-0238  
<http://www.eea.epson.com>

#### Taiwan, R.O.C.

Epson Taiwan Technology  
& Trading Ltd.  
10F, No. 287  
Nanking East Road  
Sec. 3, Taipei, Taiwan, R.O.C.  
Tel: 02-2717-7360  
Fax: 02-2712-9164

#### Hong Kong

Epson Hong Kong Ltd.  
20/F., Harbour Centre  
25 Harbour Road  
Wanchai, Hong Kong  
Tel: 2585-4600  
Fax: 2827-4346

#### Europe

Epson Europe Electronics GmbH  
Riesstrasse 15  
80992 Munich, Germany  
Tel: 089-14005-0  
Fax: 089-14005-110

#### Singapore

Epson Singapore Pte., Ltd.  
No. 1  
Temasek Avenue #36-00  
Millenia Tower  
Singapore, 039192  
Tel: 337-7911  
Fax: 334-2716

### 7.2 NEC Electronics Inc.

#### NEC Electronics Inc. (U.S.A.)

Santa Clara  
California  
Tel: (800) 366-9782  
Fax: (800) 729-9288  
<http://www.nec.com>

**THIS PAGE LEFT BLANK**