

# UPP Piping

---

## Installation Guide Overview

## Safety

### Important!

**UPP Systems must only be installed by fully trained and certified installers.**

**Failure to follow installation instructions will invalidate warranty and installer certification!**

### Piping Installation Safety

- UPP Welding Units must never be operated in Zone 1 or Zone 0 areas (Hazardous area definitions are from IP Model Code of Safe Practice Part 15 and are available in the APEA Blue Book 2nd Edition).
- Ensure Welding Units are connected to a power supply that meets the requirements detailed in the user manual and are within the requirements of any local authority or regional legislation.
- Important to any type of piping system is to safely connect all metallic components to ground. Metallic components, and more general conductive materials, due to their high capacitance, can have the potential to store high amount of electrostatic energy (sparks discharge can only be observed over conductive elements).
- All exposed metal parts used in UPP System installations should be adequately grounded to a dedicated earth electrode and brought to a potential equal to that of other metal parts in the close proximity.

### Chemical Safety

- Where using chemicals (such as Acetone) during the installation of UPP systems products, be sure to follow all safety guidelines given on the chemical containers themselves or on any accompanying literature.

### Confined Space

- Some installation of UPP products may occur in confined spaces where a lack of oxygen and a concentration of toxic vapors is likely to be experienced.

**Such working conditions are dangerous and all local health and safety guidelines for working in such environments should be followed.**

### Material Handling

#### Protective Equipment

- Ensure the correct personal protective equipment (PPE) is used at all times in line with local health and safety requirements.

#### Material Safety Data

- Ensure all safety data is accessed and used while installing UPP Systems (Material Safety Data Sheets are available in the download area of the UPP website).

#### Transport & Storage

- UPP products should be transported and stored in accordance with the guidelines contained in this manual.

#### Heavy items

- Heavy items should be handled using suitable lifting equipment operated by authorised personnel.

## Contents

<b>Safety</b> .....	<b>2</b>
<b>Introduction</b> .....	<b>3</b>
Underground Fuel Pipe Construction .....	3
<b>Transit, On-loading and Storage</b> .....	<b>4</b>
Uncoiling Pipe .....	4
<b>Site Preparation</b> .....	<b>5</b>
<b>Pipe Burial Guidelines</b> .....	<b>5</b>
Pipe Bend Radius .....	6
Completion Records .....	6
Pipe Detector Tape .....	7
<b>Pressure Testing</b> .....	<b>7</b>
Testing Guidelines. ....	7
UPP Recommended Pipe Test Procedure .....	8
Hydrostatic Pressure Testing Method.....	8
<b>Sump Inspection Register</b> .....	<b>10</b>

## Introduction

### Underground Fuel Pipe Systems

Several types of underground fuel pipe are available for different applications and to meet various engineering and legal requirements:

- UPP Extra lined primary pipe with 100% nylon barrier for product, suction, pressure, vapor vent and fill lines
- UPP Integral Secondary Containment pipe - for pressure systems or environmentally sensitive sites.
- UPP electrical conduit pipe- for underground electrical wiring protection.

UPP piping systems are designed in various diameters, from 32-160 mm (1"-6") for the transfer of fuels in filling station fore courts, marinas, and airports. UPP systems are also used for government and military installations as well as many industrial sites such as mines and rail depots.

There is no requirement for a concrete trench because fusion welded HDPE pipe is structurally resistant to weight of backfill material and dynamic traffic loads. Over 20 years experience show no failures in underground fuel pipe systems and no loss into the ground.

### Underground Fuel Pipe Construction

Black outer structural layer of the pipe is High Density Polyethylene (HDPE), grade PE80 or PE100 which allows the use of electrofusion couplers and fittings to construct a variety of pipeline configurations. HDPE PE80 and PE100 has well proven resistance to: stress cracking, puncture, scratch, impact, microbial and rodent attack.

The intermediate layer is a tie-layer (adhesive) which permanently bonds the polyethylene layer to the barrier layer.

The yellow inner barrier layer of UPP Extra pipe is specially formulated "fuel proof" barrier layer which has exceptional resistance to absorption and permeation of both gasoline and alcohol fuel blends.

The smooth bore and low friction loss of UPP pipe permits higher fuel and vapor flows when than steel pipe, reducing the pumping energy costs.

UPP underground fuel pipe is pressure rated to 90 psi (6.2 bar) according to UL971. Rupture pressure is typically exceeding 580 psi (40 bar) providing a large margin of safety.

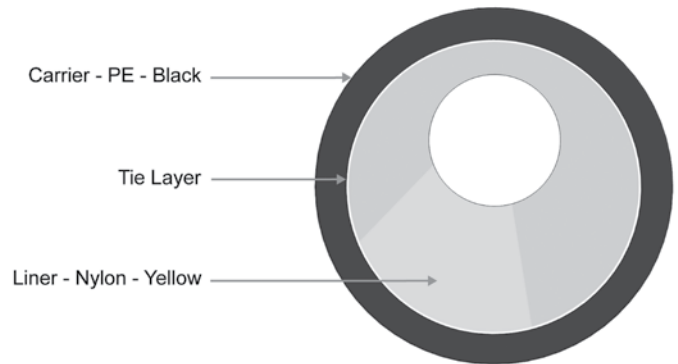

**Figure 1: UPP Pipe Structure**

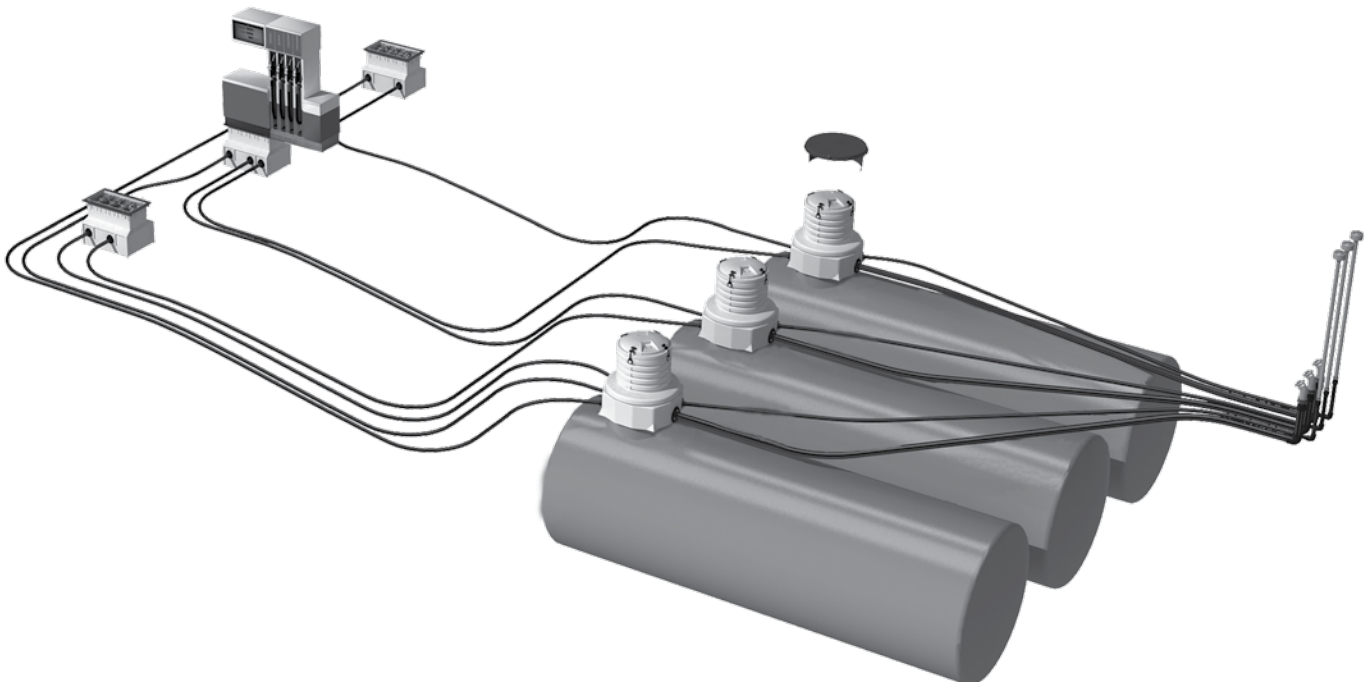

**Figure 2: Installation Overview**

## Transit, On-loading and Storage

Although UPP polyethylene pipe and fittings are extremely hard wearing and resilient, it is important to handle and store them with care to prevent scuffing or gouging. Any damaged pipes may need to be rejected and not installed.

UPP products should be transported in a flat-bedded vehicle, free from sharp objects and projections. Wide polypropylene slings must be used when lifting pipe crates by crane. Avoid using chains, hooks or hawsers.

A spreading beam should be used when lifting crates containing pipe lengths greater than 19ft 8" (6m)

- Allow for a slight bending of the pipe crates when on and off-loading.
- Standard 19ft 8" (6m) crates may be moved using a forklift. A side loader fitted with a minimum of four supporting forks should be used for longer lengths. Otherwise use a crane fitted with a spreader beam.
- When using a forklift to on or off-load coils, the forks should be covered to avoid damage to the coiled pipe.



**Figure 3: Moving Coils**

### Storage on site

- Individual pipe lengths should be stacked not more than 3ft (1m) high with the bottom layer fully restrained by wedges. The bottom layer of pipes should be laid on timber battens at 3ft (1m) centres to avoid any damage from sharp objects lying on the ground.
- Pipe crates should be stored on clear, level ground and should never be stacked more than three crates high.
- Coils should be stored on firm level ground that has suitable protection for the bottom of the coil. Stacked coils should never exceed three coils high. Individual coils should be stacked flat. If stored on edge, they must be secured against a properly anchored support and stored like this for a short period of time only, particularly in warm weather conditions.
- Badly stacked coils and pipe lengths can slip causing personal injury or damage to the product. Facilities for safe lifting and moving must be available.
- Pipes are supplied with distinctive colored end caps to prevent entry of any contamination. These end caps must be kept in place during storage.

- UPP fittings - all electrofusion fittings are packed in heat-sealed polyethylene bags and delivered in cardboard cartons. Fittings should be stored in their packaging and in a dry area, away from direct sunlight, until ready for use. This is particularly important for electrofusion fittings. These must be kept in their packaging until ready for use to prevent any contamination or oxidation.

## Uncoiling Pipe



**Figure 4: Uncoiling Pipe**

**Caution**  **The pipe can straighten with considerable force. Take care when releasing pipe from the coil and secure the straightened pipe.**

Let the pipe rest in its uncoiled state for about eight hours. High ambient temperatures can reduce this "layout" time and low temperatures may increase it. Pipe can be laid in its final position to "relax" before connecting up.

- You need at least two people to uncoil and cut the pipe. The coil is taped up in layers to make it easier to uncoil at manageable intervals.
- The area in which the pipe is uncoiled on site must be clear, safe and free of sharp objects.
- Remove the tape around the tail end on the outer winding and secure this end.
- With the coil in the vertical position, roll the coil out cutting and removing tape as you find it (ensuring to release only the next turn of pipe in the coil).
- Do not drag the pipe.
- The natural curves from coiling can be used to change pipe direction and bags of sand, pea gravel or stakes can be used to hold it in place until it is ready for connecting.
- One person should hold the pipe whilst another cuts it to the desired length.
- The cut ends will have a prominent hook that can be partially removed when weight is placed on it (bags of sand or pea gravel), or use the hook end to your advantage when turning direction into a chamber or pump sump.

## Site Preparation

### Site inspection:

Make sure the site is prepared and ready. The tanks and sumps should be in place

### IMPORTANT!

The site should be free from previous fuel contamination.

## Pipe Burial Guidelines

Recommended burial depth of UPP pipe is a minimum of 12" (300 mm).

- All trenches should be sloped back towards the storage tanks. The fall back (slope) for all pipework to the tank chambers should be a minimum of 1/8" per foot or 1 m every 100 m (Figure 7). This may vary to meet local requirements. The position of the entry fittings at the furthest dispenser sump away from the tank chambers may be considerably higher than that of the entry fittings on the closest dispenser sump.
- Vapor return lines should have a slope of 1/4" per foot and never less than 1/8" per ft. back towards the tank farm, unless in-line joints such as elbows are to be used.
- Trench corners should have a radius of 5 ft (1.5 m).
- A recommended 6" (15 cm) bed of backfill material should be laid underneath the pipe prior to installation and there must never be voids under or around the pipe. Acceptable backfill materials are:
  - Well-rounded pea gravel size 1/8" (3 mm) to 3/4" (20 mm)
  - Crushed rock size 3/4" (3 mm) to 5/8" (16 mm)
  - Clean washed sand
  - Backfill material must not be contaminated with any petroleum product or other contaminant

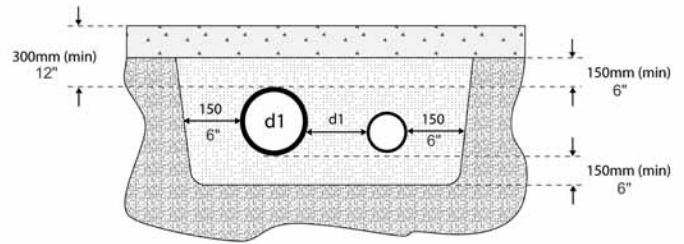

Figure 5: Pipe Spacing

- When laying duct onto a concrete base a 6" (150 mm) thick bed of compacted sand should be laid on the concrete, below the duct. (The minimum amount of sand should be 2" (50 mm) of compacted sand)
- All beds should be laid so that the pipe will not dip or sag when it is installed.
- Laying of pipe should start from the tank farm
- Underground pipe runs may be continuous or have electrofusion welded joints. Any mechanical joints or compression fittings must be located within a containment chamber or sump.

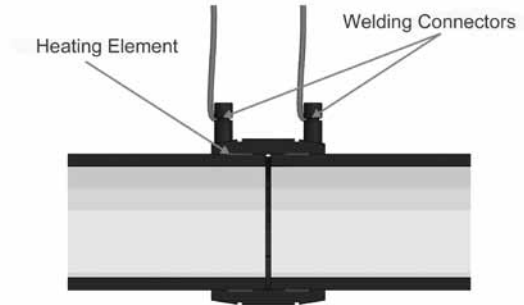

Figure 6: Electrofusion Welded Fitting Detail

Refer to manual FFS-0123 for information about the electrofusion process.

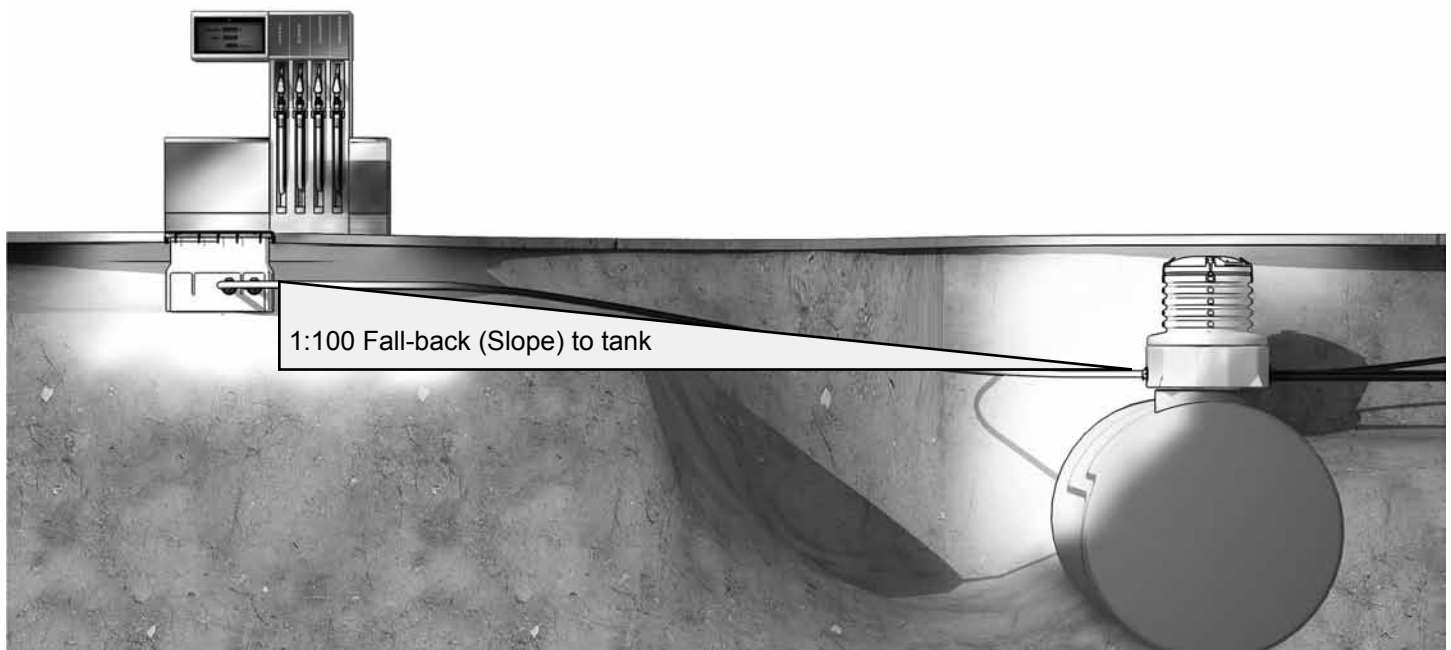
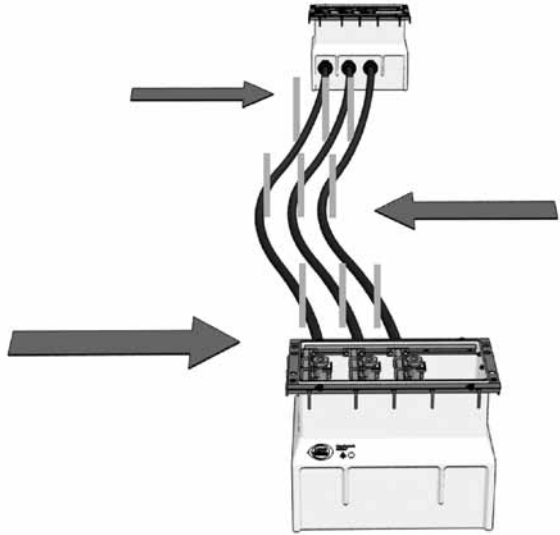

Figure 7: Fall-back (slope) to Tank

- UPP pipe exceeding 12 m (39ft) should be laid in a series of large snake-like curves and not in straight lines. Uncoiled pipe, when laid, will settle in a natural curve.



**Figure 8: Using Temporary Stakes to Snake Pipe**

- Generally any thermal expansion will be accounted for by following our guidelines for spacing, backfilling and ensuring runs are “snaked”.
- Pipes should be separated from each other by at least the diameter of the largest pipe.
- If pipe-runs cross each other they must be separated by at least as much backfill material as the diameter of the largest pipe or protected using at least 1" (25 mm) of Styrofoam.

**Pipe Bend Radius**

Temperature	Single Wall Pipe				
	(1 ") 32 mm	(1½") 50 mm	(2") 63 mm	(3") 90 mm	(4") 110 mm
>59°F (>15°C)	1 ft 7" (0.5m)	2 ft 6" (0.75m)	3 ft (0.9m)	7ft 4" (2.25m)	9ft (2.75m)
32 - 59°F (0 - 15°C)	2 ft 7" (0.8m)	4 ft 1" (1.25m)	5ft 2" (1.58m)	10ft 4" (3.15m)	12ft 8" (3.85m)
< 32°F (< 0°C)	3ft 8" (1.12m)	5ft 9" (1.75m)	7ft 3" (2.2m)	13ft 2" (4m)	16ft (4.9m)

Temperature	Double Wall Pipe				
	(1 ") 40/32 mm	(1½") 63/50 mm	(2") 75/63 mm	(3") 110/90 mm	(4") 125/110 mm
> 59°F (> 15°C)	2ft (0.6m)	3ft (0.9m)	3ft 8" (1.12m)	9ft (2.75m)	10ft 2" (3.1m)
32 - 59°F (0 - 15°C)	3ft 3" (1m)	4ft 11" (1.5m)	1.88m (6ft 2")	3.85m (12ft 8")	4.4m (14ft 5")
< 32°F (< 0°C)	4ft 7" (1.4m)	7ft 3" (2.2m)	8ft 6" (2.6m)	16ft (4.9m)	18ft 4" (5.6m)

Temperature	UL971 Pipe					
	(2") 63 mm	(3") 90 mm	(1½") 63/50 mm	(2") 75/63 mm	(3") 110/90 mm	(4") 125/110 mm
> 59°F (>15°C)	3ft 3" (1m)	9ft 10" (3m)	3ft 3" (1m)	3ft '3" (1m)	13ft 2" (4m)	13ft 2" (4m)
32-59°F (0-15°C)	5ft 3" (1.6m)	16ft 5" (5m)	5ft 3" (1.6m)	5ft 3" (1.6m)	19ft 8" (6m)	19ft 8" (6m)
< 32°F (< 0°C)	7ft 2" (2.2m)	23ft (7m)	7ft 2" (2.2m)	7ft 2" (2.2m)	26ft 3" (8m)	26ft 3" (8m)

**Table 1: Allowable Bend Radius**

- If used above ground, UPP pipe should be protected against mechanical, climatic damage. Additional supports and anchor points may also be required. Check fire codes for proper installation.
- Mark positions on the tank access chamber/sump for penetration locations and install UPP seals.

**Bend Radius**

The UPP piping systems have a semi-rigid construction which gives both strength and flexibility.

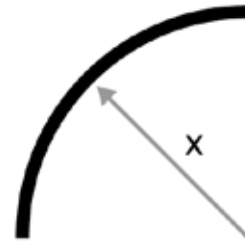

**Figure 9: Bend Radius**

Refer to Table 1 for allowable bend radius of UPP Pipe.

**Important: Completion Records**

- On completion of UPP installation make an “as constructed” drawing showing the exact location of all below ground lines. It is also recommended that, in addition, a photographic record is preserved.

## Pipe Detector Tape

UPP Detectable tape is used to allow the piping location to be found after it has been covered. The tape is installed below ground at 9.8 inches (250mm) height directly above pipe runs to indicate the position of each pipe.

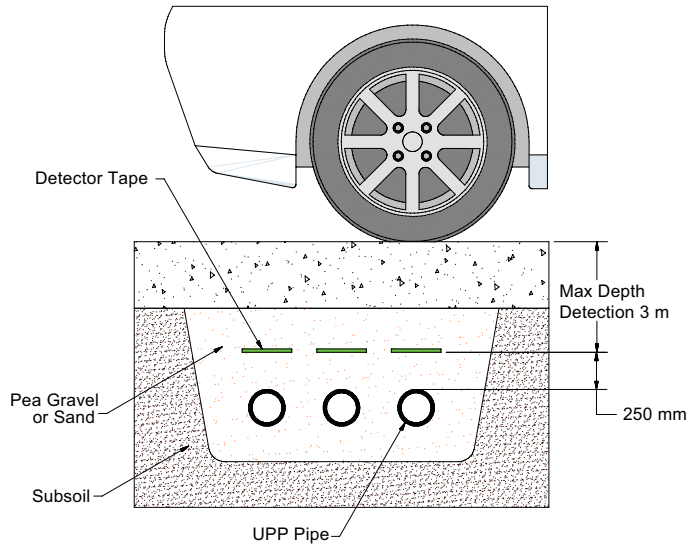

**Figure 10: Detector Tape Installation**

Both ends of the tape should be grounded during installation.

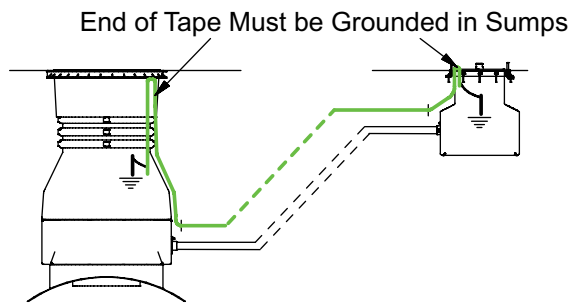

**Figure 11: Detector Tape must be Grounded**

When using a detection tool, the near end of the detectable tape should be disconnected from the grounding point to allow the red cable from the transmitter to be connected to the tape and the black cable from the transmitter to be connected to the grounding point.

The far end of the tape should remain grounded to give the highest signal strength and the earth spike should be as far away from the trace path as possible at a 90 degree angle.

Use the lowest frequency possible from the transmitter around 577 Hz or 8 KHz to eliminate coupling to other grounded cables.

Use the receiver to follow the path of the tape to locate the buried pipe. Follow direction included with the receiver and transmitter for detecting buried pipe location.

## Pressure Testing

Following inspection and prior to backfilling, a tightness test should be carried out by a competent person on each pipe run, chamber and sump to verify the integrity of joints and seals. This testing should meet the requirements of local officials and engineers and comply with local health and safety regulations.

The following testing procedure is suggested for guidance only and should in no way override oil companies or local regulator's requirements.

## Testing Guidelines.

### Equipment

- Target test pressure should be 50% of scale on gauge, e.g. if the test pressure is 14.5 psi (1 Bar), use a 29 psi (2 Bar) gauge.
- Gauges should have serial numbers and be tested / certificated yearly.
- Pressure testing equipment should have fitted a relief valve set at around 7.25 psi (0.5 bar) above the test pressure.

### General Guidelines

- When applying pressure from gas cylinders, use suitable valves to ensure test pressure is not exceeded.
- Apply pressure or vacuum slowly to minimise risks.
- When tightness testing primary pipe the secondary should be open to atmosphere this is critical whenever secondary pipe is filled with liquid.
- Secondary pipe should ideally not be welded prior to testing primary to allow inspection of joints.
- When tightness testing secondary pipe the primary should be open to atmosphere.
- Wipe each joint with soapy water to check for leaking.

### Caution

- To avoid explosion hazards, nitrogen or an inert gas from a pressure cylinder should be used in place of compressed air for tightness testing if fuel has been used to ballast underground storage tanks or if pipe-work has previously contained petroleum.
- Pipe-work should be disconnected (isolated) from underground storage tank prior to commencing tightness testing.
- Any water used for testing should be disposed of through the oil/water separator or by a specialist contractor and in accordance with any local environmental health and safety requirements and regulations.

There are three tightness testing methods suitable for use with UPP systems: Pneumatic, Vacuum and Hydrostatic; any of these methods can be used to prove the tightness of a line. Tightness testing using a Hydrostatic method is suitable for testing at high pressures. The UPP pneumatic and vacuum tightness tests should both be carried out to ensure confidence in the installation at lower pressures.

# UPP Recommended Pipe Test Procedure

## Primary Pipe Hydrostatic Pressure Testing Method

### Equipment

- Pump rated for more than 145 psig (10 bar)
- Hydrofor (reservoir or pressure tank)
- Two pressure gauges, rated for 174 psig (12 bar), min. reading 2 psig (0.1 bar)
- Check valve
- Ball valve
- Pressure relief valve rated for 290 psig (20 bar), set at 159 psig (11 bar)

### Conditioning Phase

- Fill the pipe work system to be tested with water, making sure that any air relief valves are opened while filling the pipe work.
- After filling the pipe work wait 1 hour for the temperature to stabilize.
- Pressurize the system to 145 psi (10 bar) and maintain this pressure for 30 minutes. (System pressure shall be maintained by means of refilling in order to compensate for the increase in volume due to the expansion of the pipe-work). At this time the system should be thoroughly inspected for leakage. After any such areas have been remedied repeat the conditioning before proceeding to the testing phase.

### Testing Phase

- Rapidly reduce the system pressure to 43.5 psi (3 bar) by bleeding water from the pipe-work. (Due to the visco-elastic properties of polyethylene the pipe will contract).

- During the test period of 90 minutes the pressure should be recorded with the frequency shown below:

Test period (mins)	Frequency of readings (mins)	Number of readings
0-10	2	6
10-30	5	4
30-90	10	6

**Table 2: Recording Test Results**

- The test is passed if all the readings during the testing cycle are 43.5 psi (3 bar) or above.
- Decreasing readings = failure of pressure test. (Note that the readings are likely to increase)
- If the system fails the pressure test make the following checks:
  - Check all mechanical connections
  - Check welded joints
- When the failure point has been located and remedied repeat the full conditioning and testing sequence.

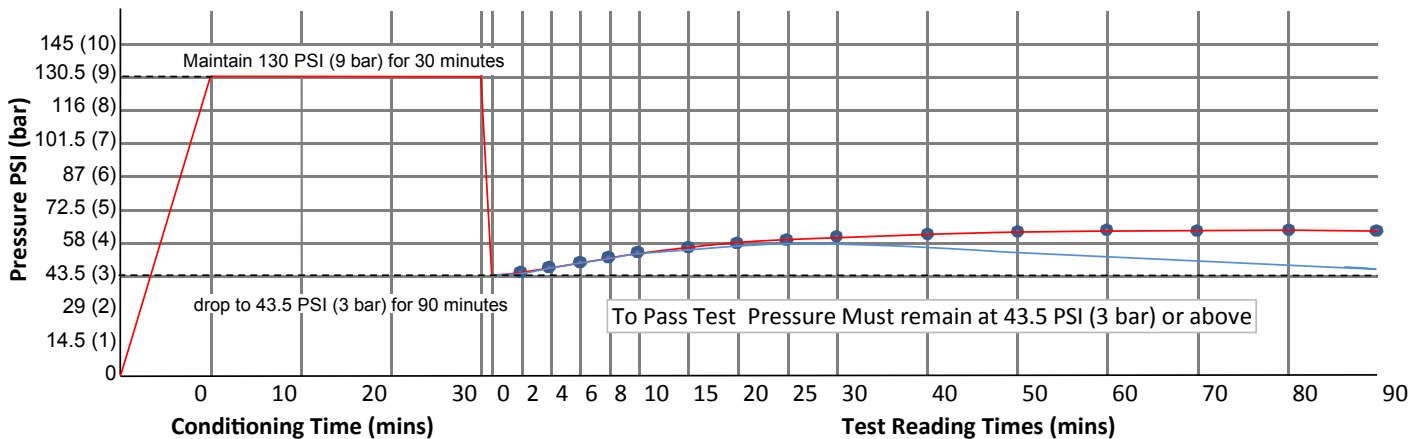

**Hydrostatic Testing Graph**



## UPP Pneumatic Tightness Testing Method Procedure

Refer to ASTM International Document F2786-10 for overall pneumatic testing information.

### Test Pressure

- 50 PSI ( 3.5 bar) for pipe up to 2"
- Use operating pressure for Piping/Fittings over 2".
- When testing secondary pipe terminated with flexible boot, pressure test at 0.5 bar (7 psi) for 30 minutes following a 15 minutes conditioning at test pressure.
- **Never** exceed the maximum pressure rating (table 5).
- Record Temperature and Pressure at start of each test time.
- Condition the piping as below:
  1. Pressurize the piping to 10% of test pressure. Hold pressure for 30 minutes and inspect for leakage or pressure drop.
  2. Increase pressure to 50% of test pressure and again inspect for leakage while holding pressure for 30 minutes.
  3. Increase pressure to 100% of test pressure and again inspect for leakage while holding pressure for 30 minutes.
- Record Temperature and Pressure at end of each test time.
- If results are within criteria of Table 3 Tightness Test is passed.

### Pressure Testing Safety

Follow these guidelines when doing pneumatic testing:

- Wear Safety glasses.
- Relieve air pressure at the completion of each test phase and before any corrective actions are taken.
- Never exceed the pressure rating of components when testing.
- Allow only necessary and authorized persons in the proximity of pipe being tested.
- Restrain the movement of connections, joints and seals during testing.

Acceptable Pressure Variation							
	Initial Pressure 3.5 bar						
Temperature variation $\Delta T$ (°C)	-15	-10	-5	0	5	10	15
Final pressure due to temperature change (bar)	3.32	3.38	3.44	3.5	3.56	3.62	3.68
	Initial Pressure 50 psi						
Temperature variation $\Delta T$ (°F)	-30	-20	-10	0	10	20	30
Final pressure due to temperature change (psi)	47.2	48.1	49.1	50	50.9	51.9	52.8

**Table 3: Pressure Variation with Temperature Change**

## Vacuum Testing

Pneumatic Vacuum Tightness Testing			
Type of Test	Conditioning	Test Vacuum	Test Time (Mins)
Tank Chamber / Dispenser Sump	3 mins @ 2x Test Vacuum	-30 mbar, -0.44 psi, -3 kPa	7
Spill Container	3 mins @ 2x Test Vacuum	-30 mbar, -0.44 psi, -3 kPa	1.5

**Table 4: Vacuum Testing**

## Pressure Ratings

Maximum Pressure Rating (UL971)		
Pipe type	Pressure Rating (Bar)	Pressure Rating (PSI)
UPP Primary	6	90
UPP Secondary	4	58

**Table 5: UL971 Pipe Maximum Pressure Rating**

Maximum Pressure Rating (EN14125)		
Pipe type	Pressure Rating (Bar)	Pressure Rating (PSI)
UPP Primary	10	145
UPP Secondary	4	58

**Table 6: EN14125 Pipe Maximum Pressure Rating**

Secondary Pipe Testing Pressure Rating		
Secondary Test Pressure	Bar	PSI
Rubber boots	0.5	7
Welded Boots	3.5	50

**Table 7: Secondary Testing Pressures**



Page Intentionally Blank



[www.franklinfueling.com](http://www.franklinfueling.com)

3760 Marsh Road  
Madison, WI 53718, USA  
Tel: +1 608 838 8786  
Fax: +1 608 838 6433  
USA & Canada Tel: 1 800 225 9787

México Tel: 001 800 738 7610

Brazil Tel: +55 11 3395 0606

UK Tel: +44 1473 243300

**Franklin Fueling Systems GmbH**  
Rudolf-Diesel-Strasse 20  
54516 WITTLICH, Germany  
Tel: +49 6571 105 380  
Fax: +49 6571 105 510

France Tel: +49 6 57 11 05 380

China:Tel: +86 10 8565 4566  
Fax: + 86 10 8565 4766  
A802, ChaowaiMEN Center  
No. 26 Chaowai Street  
Chaoyang District  
Beijing 100020, China