

Horizontal Electrophoresis System

Model D2 and D3-14

Operating and Maintenance Manual 7007320 Rev. 1

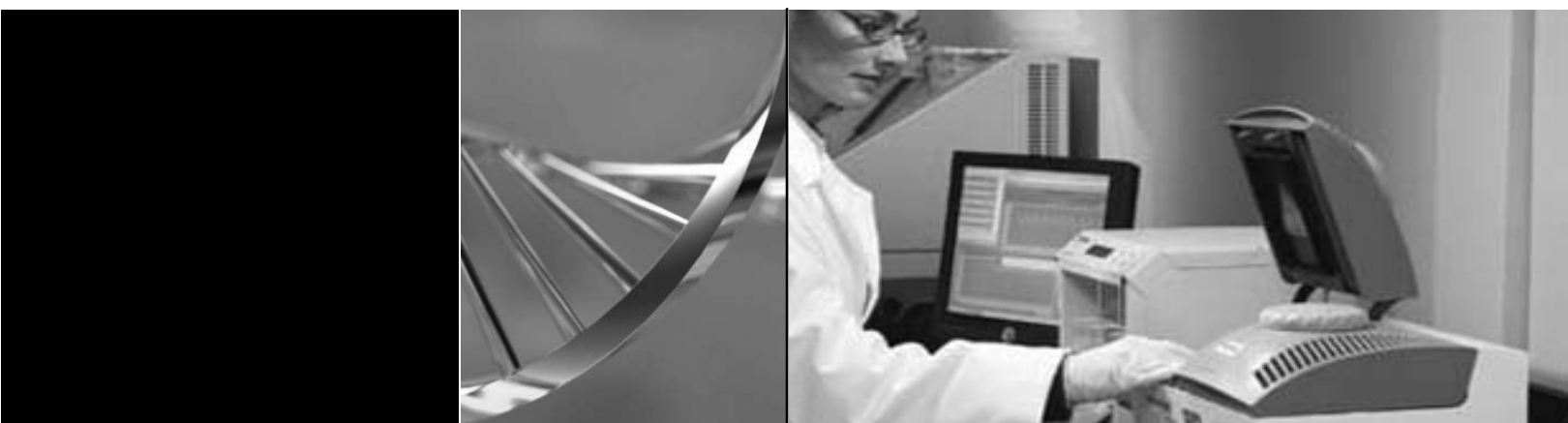

Visit us online to register your warranty
www.thermoscientific.com/warranty





Model D3-14 Horizontal Gel System



Model D2 Horizontal Gel System

MANUAL NUMBER 7007320

1	28432/SI-11500	9/10/12	Added lid assembly part number to pg 1-2 parts list	ccs
0	--	5/29/12	Transferr to Marietta (was Rev Date 3/2005)	ccs
REV	ECR/ECN	DATE	DESCRIPTION	By



Important Read this instruction manual. Failure to read, understand and follow the instructions in this manual may result in damage to the unit, injury to operating personnel, and poor equipment performance. ▲

Caution All internal adjustments and maintenance must be performed by qualified service personnel. ▲

Warning To avoid the risk of personal shock, always disconnect the gel box from the power supply. Further, the power supply must be equipped with a shut-down-on-disconnect circuit. Do not move the unit unless the power source to the unit has been disconnected. Running conditions for this unit should not exceed the name plate readings found on the lower buffer chamber. NEVER leave unit running unattended. ▲

Statement of Proper Use: Use this product only for its intended purpose as described in this manual. Do not use this product if the power leads are damaged or if any of its surfaces are cracked.

Material in this manual is for information purposes only. The contents and the product it describes are subject to change without notice. Thermo Fisher Scientific makes no representations or warranties with respect to this manual. In no event shall Thermo be held liable for any damages, direct or incidental, arising out of or related to the use of this manual.

©2012 Thermo Fisher Scientific. All rights reserved.



Important operating and/or maintenance instructions. Read the accompanying text carefully.



Potential electrical hazards. Only qualified persons should perform procedures associated with this symbol.



Equipment being maintained or serviced must be turned off and locked off to prevent possible injury.



Hot surface(s) present which may cause burns to unprotected skin, or to materials which may be damaged by elevated temperatures.



Marking of electrical and electronic equipment, which applies to electrical and electronic equipment falling under the Directive 2002/96/EC (WEEE) and the equipment that has been put on the market after 13 August 2005.



This product is required to comply with the European Union's Waste Electrical & Electronic Equipment (WEEE) Directive 2002/96/EC. It is marked with the WEEE symbol. Thermo Fisher Scientific has contracted with one or more recycling/disposal companies in each EU Member State European Country, and this product should be disposed of or recycled through them. Further information on Thermo's compliance with this directive, the recyclers in your country and information on Thermo products will be available at www.thermofisher.com.

- ✓ Always use the proper protective equipment (clothing, gloves, goggles, etc.)
- ✓ Always dissipate extreme cold or heat and wear protective clothing.
- ✓ Always follow good hygiene practices.
- ✓ Each individual is responsible for his or her own safety.

Do You Need Information or Assistance on Thermo Scientific Products?

If you do, please contact us 8:00 a.m. to 6:00 p.m. (Eastern Time) at:

1-740-373-4763

1-800-438-4851

1-877-213-8051

<http://www.thermoscientific.com>

service.led.marietta@thermofisher.com

www.unitylabservices.com

Direct

Toll Free, U.S. and Canada

FAX

Internet Worldwide Web Home Page

Tech Support Email Address

Certified Service Web Page

Our **Sales Support** staff can provide information on pricing and give you quotations. We can take your order and provide delivery information on major equipment items or make arrangements to have your local sales representative contact you. Our products are listed on the Internet and we can be contacted through our Internet home page.

Our **Service Support** staff can supply technical information about proper setup, operation or troubleshooting of your equipment. We can fill your needs for spare or replacement parts or provide you with on-site service. We can also provide you with a quotation on our Extended Warranty for your Thermo Scientific products.

Whatever Thermo Scientific products you need or use, we will be happy to discuss your applications. If you are experiencing technical problems, working together, we will help you locate the problem and, chances are, correct it yourself...over the telephone without a service call.

When more extensive service is necessary, we will assist you with direct factory trained technicians or a qualified service organization for on-the-spot repair. If your service need is covered by the warranty, we will arrange for the unit to be repaired at our expense and to your satisfaction.

Regardless of your needs, our professional telephone technicians are available to assist you Monday through Friday from 8:00 a.m. to 6:00 p.m. Eastern Time. Please contact us by telephone or fax. If you wish to write, our mailing address is:

Thermo Fisher Scientific
401 Millcreek Road, Box 649
Marietta, OH 45750

International customers, please contact your local Thermo Scientific distributor.

Table of Contents

Section 1	Introduction	1-1
	Model D2 Wide Electrophoresis System	1-2
	Model D3-14 Wide Electrophoresis System	1-3
Section 2	Casting a Gel	2-1
Section 3	Using the System	3-1
	Running a Gel	3-1
	Loading the Sample in Gel	3-2
	Finish	3-3
Section 4	Care and Cleaning	4-1
Section 5	Reagents Information	5-1
	Selection of Reagents for Gel Electrophoresis	5-1
Section 6	Troubleshooting	6-1
Section 7	Specifications	7-1
Section 8	Optional Equipment	8-1
	Buffer Exchange Port	8-1
	Combs	8-2
	How to Determine Well Sample Volume	8-4
Section 9	Warranty Information	9-1

Section 1 Introduction

The Owl Model D3-14 and Model D2 Horizontal Agarose Gel Electrophoresis Systems are designed to provide flat, even banding patterns and consistent results with hassle-free gel casting. No tape, grease, agarose seals or other accessories are required. A stand-alone casting platform is included for casting 1 or 2 (D2 only) gels simultaneously. Custom combs are available upon request.

BEFORE STARTING -- Unpack the unit and inventory your order. If any parts are missing, contact Technical Services within 48 hours. Reference the order or catalog number on your invoice and check the corresponding part lists.

Model D2 Wide Electrophoresis System

Gel Size:14.4cm W x 10.2cm L
Footprint:17cm W x 17cm L x 10cm H
Running Buffer Volume:600ml

COMPLETE SYSTEM INCLUDES:

- Buffer Chamber
- SuperSafe™ Lid with Attached Power Supply Leads
- EasyCast™ Gasketed U.V. Transmissible (UVT) Gel Tray
- External Multiple Gel Caster
- 4 Combs: (2) 30 Well and (2) 40 Well

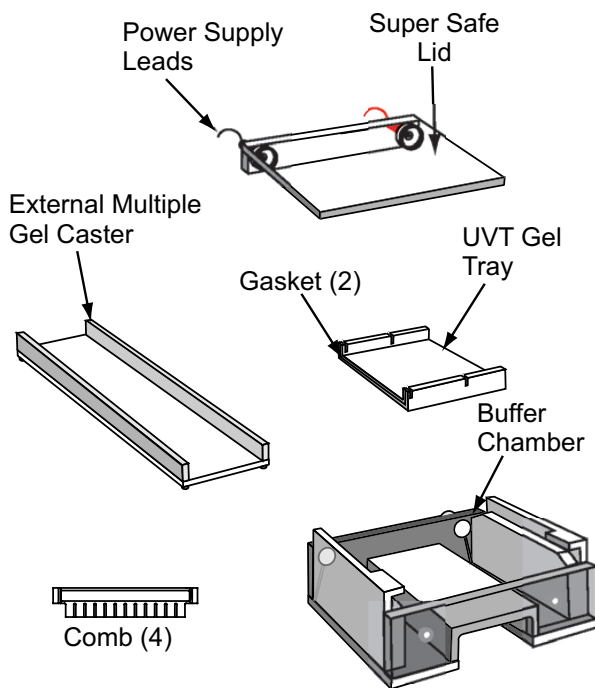

Item Description	Catalog No.
Complete System	D2
Complete System with Buffer Exchange Ports	D2-BP
Accessories	Catalog No.
Power Supply Leads	PSL-5
Gasketed EasyCast™ UVT Gel Tray	D2-UVT
Replacement Gaskets (1pair)	D2-GK
External Multiple Caster (trays not included)	D2-CST
Leveling Platform 36cmW x 46cmL	B-LP
Bubble Level	BBL-1
Lid Assembly	256116

Model D3-14 Wide Electrophoresis System

Gel Size:23cm W x 14cm L
 Footprint:26cm W x 29cm L x 8cm H
 Running Buffer Volume:800ml

COMPLETE SYSTEM INCLUDES:

- Buffer Chamber
- SuperSafe™ Lid with Attached Power Supply Leads
- EasyCast™ Gasketed U.V. Transmissible (UVT) Gel Tray
- External Gel Caster
- 4 Combs: 30 Well, 1.5mm Thick

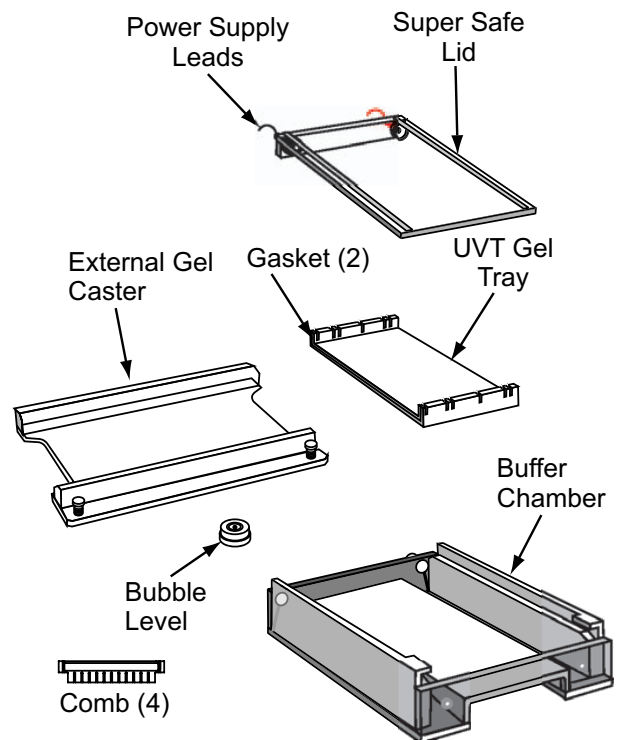

Item Description	Catalog No.
Complete System	D3-14
Accessories	Catalog No.
Power Supply Leads	PSL-5
Gasketed EasyCast™ UVT Gel Tray	D3-UVT-14
Replacement Gaskets (1pair)	D3-GK
External Multiple Caster (trays not included)	D3-CST-14
Leveling Platform 36cmW x 46cmL	B-LP
Bubble Level	BBL-1
Casting Dam (23cm)	DAM-23

Section 2 Casting a Gel

1. **Remove the SuperSafe™ lid** from the gel box by holding the front of the buffer chamber with one hand and pulling the lid off; sliding off evenly by holding the center of the back of the lid. The cover is attached to the back of the unit at the junction of the lids attached power cords to the banana plugs.
2. **For shipping and convenient storage**, the gasketed gel tray is packaged inside the external gel caster upon arrival. To remove the gel tray, lift it out of the caster by placing both hands firmly on the shorter tray ends and pull up slowly from the caster at an angle. Tray needs to fit snug for leakproof gel casting, so it may be tight. “Walking” the tray upward at an angle may be helpful.
3. **To cast gels**, place the gel tray into the external gel caster making sure the tray is pushed all the way down and level in the external gel caster. For best results, be sure to cast on a level surface. Leveling platforms are available through Technical Services, Catalog No. B-LP.

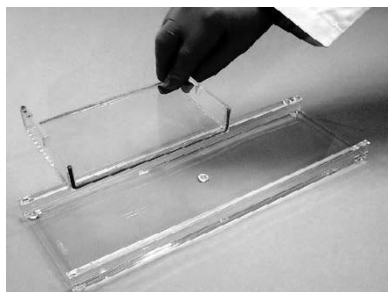

Figure 2-1. Model D2

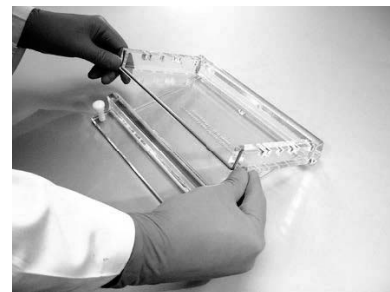

Figure 2-2. Model D3-14

4. **Casting a Level Gel** - The need to cast a level gel is very important for consistent reproducible results. Level the caster by placing the enclosed bubble level (Model D3-14 only, order B-LP for Model D2) in the center of the gel tray. Using the thumbscrews on each side of the caster, slowly turning one thumbscrew (front only) at a time and lining up the bubble in the level with the center circle. Check various areas on the gel tray by moving the bubble level to each end of the gel tray to ensure you have leveled correctly.

Note It is wise to always run a sample lane of a known “standard ladder” to determine concentration and size of separated fragments after the gel run, and to aid in photo documentation and analysis. ▲

5. **Preparing the Gel** - Using electrophoresis grade agarose and compatible electrophoresis buffer the gel may be prepared in various ways. The percentage of agarose and the electrophoretic buffer used is determined by the size of the samples to be separated and further recovery of the samples. The agarose and buffer are mixed and heated using a heat source, in a microwave oven, or in an autoclave until the agarose is completely dissolved. The prepared gel then must be cooled to below 60°C before casting to avoid warping the UVT gel tray due to excessive heat. If numerous gels are to be run in one day, a large volume of gel may be prepared and placed in a covered bottle stored between 40-60°C in a water bath. This provides a ready gel supply in a warm liquid form that will solidify quickly when gels are cast.
6. Pour or pipette the correct amount of warm agarose (< 60°C) onto the UVT gel tray. Immediately after pouring, insert the desired comb or combs into the comb slots to form the sample wells. If only a small portion of gel is required for proper sample separation, up to 4 combs may be used to run 2, 3 or 4 sets of equal distance samples simultaneously, expanding the number of samples per gel that may be run.

Note A higher percentage of agarose (>0.5%) may give the best results when using 4 of the 50 tooth (D3-14 only, D2 goes to 40) combs to avoid damage to the wells when combs are removed. ▲

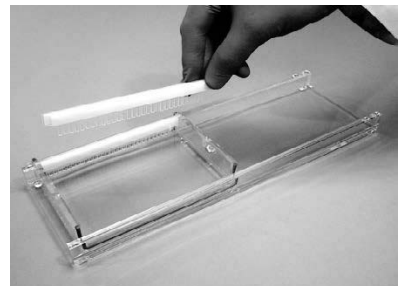
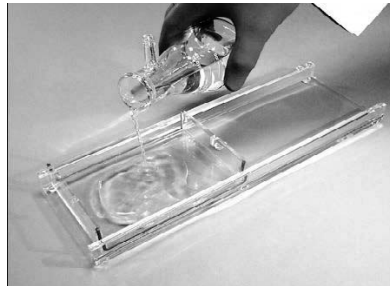

Figure 2-1. Model D2 Process

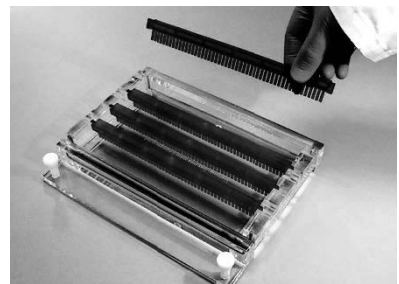
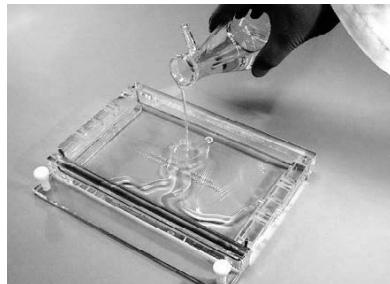

Figure 2-2. Model D3-14 Process

Wall Comb: To conserve agarose, a wall comb may also be used to divide and use a shorter length of the gel tray. If a wall comb is used, pipette a bead of agarose along the bottom and side edges of the wall comb once it has been placed in the tray to seal the combs edges to the trays bottom and sides. Once this bead is solidified, the cooled gel may be poured as described. Alternately, regular tape cut slightly longer than the comb can be placed flat along the comb's surface and the comb angled into place in the gel tray. Extra tape is then placed on the outside of the comb in the excess tray area to reinforce the corners. Allow the gel to solidify completely. Standard agarose should solidify completely in about 30 minutes. If low melting point or a specialty agarose is used, consult the instructions that came with the product.

Casting Dam: A casting dam may also be used. The dam blocks off a portion of the UVT gel tray to allow shorter gels to be cast and run in one tray. Because it is manufactured using high quality aluminum that seals the agarose upon contact, there is no need for tape. The Casting Dam is free-standing so the chosen length is not restricted (Catalog No. DAM-23).

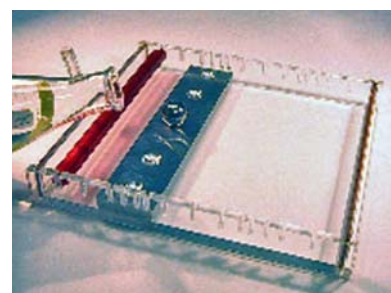

Figure 2-3. Casting Dam

Section 3 Using the System

Running a Gel

1. Once the gel is completely solidified, carefully lift the tray(s) out of the external gel caster and place into the buffer chamber. The running position of the tray exposes the open ends of the agarose to the buffer.
2. Pour enough compatible running buffer into the unit to fill both ends of buffer chamber and completely cover and submerge the gel. Correct buffer level is clearly marked on the side wall as “FILL LINE”. See Recommended Running Conditions for approximate buffer volumes needed for your unit. Too little buffer may cause the gel to dry out during the run, while excess buffer may decrease DNA mobility and cause band distortion.
3. Carefully remove the comb (or combs) by tapping lightly to loosen, and slowly lifting straight up out of the gel tray. To avoid damage to the sample wells, always make sure to allow the gel to solidify completely before moving the buffer chamber, gel tray, or removing the combs. After placing the gel tray into the unit in the running position, submerge the gel in 3-5mm of running buffer. Lightly tap each comb gently back and forth to loosen, then slowly pull the comb straight up out of the gel tray. This will break any suction that may exist between the gel and comb. When using all four combs (D3-14 model), a higher percentage of agarose (>0.5%) may be wise to avoid damage to the sample wells. Low percentage gel and the small sample wells may cause the sides of the wells to collapse when the comb is removed. A higher percentage of agarose forms a tighter gel matrix. Casting a slightly thicker gel may also remedy this problem.

Note Combs may also be removed prior to pouring buffer in buffer chamber. ▲

4. Load prepared samples into the wells. Samples should be mixed with a sample loading buffer; giving weight to the samples so that they drop evenly into the wells and contain tracking dyes to monitor the gel run. Refer to page 16. The combs supplied with the D3-14 unit are designed in a micro well format. This format allows speedy sample loading using a multi-channel pipette. The 25 tooth comb is in the 1X micro well format and matches each tip of the multichannel pipette, while the 50 tooth comb is in the 2X format; loading every other lane. The D2 has a 1X (15 well comb) and a 2X (30 well comb).

Running a Gel (continued)

5. Carefully slide the SuperSafe™ lid with attached power supply leads onto the unit. This will connect the power supply leads to the banana plug electrodes and complete the circuit. Plug the other end of the power supply leads into appropriate power supply (red to red, black to black).
6. Turn on the power supply (See Recommended Running Conditions). Carefully monitor the gel run to avoid samples running into the path of another set of samples.

Loading the Sample in Gel

There are two ways to load the gel(s), Dry Loading and Wet Loading:

DRY LOADING - loading the sample in the gel without the presence of buffer.

- a. Remove the gel tray from the casting chamber.
- b. Load the sample into the gel but be careful not to puncture the bottom of the gel. Place the gel tray into the buffer chamber in the running position.
- c. Load the sample into the gel but be careful not to puncture the bottom of the gel. Place the gel tray into the buffer chamber in the running position.
- d. Carefully fill the buffer chamber with buffer to cover UVT tray (fill line) completely cover and submerge the gel. See Recommended Running Conditions for approximate buffer volumes needed for your unit. Too little buffer may cause the gel to dry out during the run, while excess buffer may slow DNA migration in the gel.

WET LOADING - loading the sample in the gel when it is submerged in buffer.

- a. Remove the gel tray from the casting chamber.
- b. Place the gel tray into the buffer chamber in the running position.
- c. Pour running buffer into the unit to fill chamber and completely cover and submerge the gel. See Recommended Running Conditions for approximate buffer volumes needed for your unit. Too little buffer may cause the gel to dry out during the run, while excess buffer may slow DNA migration in the gel.

Loading the Sample in Gel (continued)

- d. Load prepared samples into the wells. Samples should be mixed with a sample loading buffer; giving weight to the samples so that they drop evenly into the wells, and contain tracking dye to monitor the gel run. See Table 5-2 in Section 5 for approximate well volumes.

Note To run one gel, follow steps a, b, c and d.

It is recommended to always run a sample lane of a known “standard ladder” or “marker” to determine concentration and size of separated fragments after the gel run, and to aid in photodocumentation and analysis. Migration patterns and fragment sizes for commonly used DNA molecular weight markers are shown here.

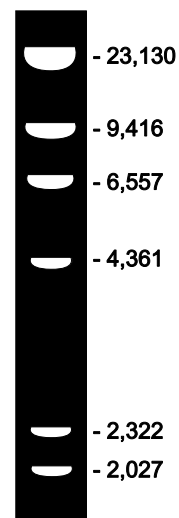

Finish

1. When the gel run is complete and tracking dye has migrated as far through the gel as desired or to the end of the gel, turn off the power supply and slide off the SuperSafe™ lid to disconnect from the power source. Carefully remove the UVT gel tray containing the gel (wear gloves if ethidium bromide is present). The UV transparent gel tray makes visualization and photography with a UV light source easy without the need to remove the gel from the tray. The UVT gel tray may be placed back into the casting chamber for convenient transport to the darkroom to avoid damage to the gel.
2. The gel box should be rinsed under warm running water after each use, including the UVT gel tray. Rinsing the UVT gel tray will avoid any salt build up in the gasket material from the electrophoretic running buffer; extending the gasket life and ensuring leak-free gel casting.

Section 4 Care and Cleaning

Caution Do not use ethanol or other organic solvents to clean these products! Organic solvents cause acrylic to “craze” or crack. Clean all acrylic systems with warm water and a mild detergent. Do not autoclave, bake, or microwave your unit. Temperatures over 50°C can do damage to the acrylic. ▲

The unit may be rinsed with warm water, or cleaned with warm water and a mild detergent to get rid of any debris.

Note If an RNase free electrophoresis system is desired, there are various methods to rid the system of RNA contamination. For fast and easy decontamination, use RNase AWAY^{®*}. Spray, wipe or soak labware with RNase Away, then wipe or rinse the surface clean; it instantly eliminates RNase. RNase Away eliminates the old methods that include treatment with 0.1% Diethyl Pyrocarbonate (DEPC) treated water and soaking in dilute bleach. DEPC is suspected to be a carcinogen and should be handled with care. This electrophoresis system should never be autoclaved, baked, or placed in a microwave.

To order RNase AWAY[®], contact Technical Services:

Part Number	Description
7000	250ml bottle
7002	475ml spray bottle
7003	1 liter bottle
7005	4 liter bottle

**Rnase AWAY[®] is a registered trademark of Molecular BioProducts*

Section 5 Reagents Information

Selection of Reagents for Gel Electrophoresis

1. Agarose

There are various types of agarose commercially available that may be used. Besides standard ultra pure electrophoresis grade agarose, there are also numerous low melting point products for easy sample recovery, as well as specialty products formulated for specific uses (i.e. to separate and/or recover very small or very large fragments).

Table 5-1. Mobility range of DNA in different percentage agarose gels

Agarose % (w/v)	Approximate range of separated DNA fragments (kb)
0.3	60 to 5
0.5	30 to 1
0.7	12 to 0.8
1.0	10 to 0.5
1.2	7 to 0.3
1.5	4 to 0.2
2.0	3 to 0.1
3.0	<0.1

Table 5-2. Amount of Agarose to prepare

Gel volume is determined by the following formula and may be adjusted according to need or preference:

$$\text{gel width (cm)} \times \text{gel length (cm)} \times \text{gel thickness (cm)} = \text{ml of agarose}$$

Model #	Gel Size (cm)	0.25cm	0.5cm	0.75cm	1.0cm
D3-14	23 x 14	80.5ml	161ml	241.5ml	322ml
D2	14.4 x 10.2	36.72	73.44	110.16	146.88

Selection of Reagents for Gel Electrophoresis (continued)

Note. An increased agarose % provides better separation of small fragments and bands very close together that tend to be more difficult to separate. A specialty agarose product formulated to increase resolution of low molecular mass samples may also be used, or an agarose additive may be added to standard or low melting point agarose.

Example: A good mid-range gel percentage would be 0.7%, or 0.7g agarose in 100ml electrophoresis buffer (TBE or TAE), following heating and dissolving the agarose, 10ul of ethidium bromide stock solution (5mg/ml) is added. The gel would be run with compatible electrophoretic running buffer (1X TBE or 1X TAE) that also contained ethidium bromide. One liter of the running buffer would contain 100ul of this 5mg/ml ethidium bromide stock solution.

2. Ethidium Bromide

For photodocumentation of samples, the gel may be stained during or following the run with a variety of stains. The most common stain for DNA is ethidium bromide. Ethidium bromide may be added directly to the gel and running buffer to visualize and photograph the separated fragments following the gel run without the need for an additional staining step. The ethidium bromide is added to both the gel (after heating) and the electrophoresis buffer at a concentration of 0.5ug/ml. Conversely, the gel may be stained in a concentrated ethidium bromide solution after the gel run and rinsed for visualization.

Warning Ethidium bromide is a potential carcinogen. Care in handling the powder and stock solution must be taken. Always wear gloves when handling the powder, solutions and all gels that contain ethidium bromide.

Table 5-3. Preparation and Properties of TAE and TBE Electrophoresis Buffer Systems

These buffers are used because they both have a basic pH which gives the phosphate group of the DNA a net negative charge allowing migration of the DNA toward the positive anode in the electrophoresis chamber.

TAE - Tris Acetate with EDTA (40mM Tris Base, 40mM Acetic Acid, 1mM EDTA)	
50X stock solution, pH 8.5:	1X working solution:
242g Tris Base	40mM Tris Acetate
57.1ml Glacial Acetic Acid	1mM EDTA
18.61g Na EDTA " 2H ₂ O (MW 372.24)	
Distilled H ₂ O to 1 Liter Final Volume	
TBE - Tris Borate with EDTA (89mM Tris Base, 89mM Boric Acid, 2mM EDTA)	
10X stock solution:	1X working solution:
108g Tris Base	89mM Tris Base
55g Boric Acid	89mM Boric Acid
7.44g Na ₂ EDTA " 2H ₂ O (MW 372.24)	2mM EDTA
(or 40ml 0.5M EDTA, pH 8.0)	
Distilled H ₂ O to 1 Liter Final Volume	

Choose the buffer best suited to the experiment. Each buffer has different properties providing the necessary ions for electrophoretic migration.

<u>Buffer</u>	<u>Suggested Use</u>
TAE Buffer	<ul style="list-style-type: none">• Use when DNA is to be recovered• For electrophoresis of large (>20kb) DNA• Applications requiring high resolution• Has low ionic strength and low buffering capacity - recirculation may be necessary for long runs (>4hrs.)
TBE Buffer	<ul style="list-style-type: none">• General Purpose Buffer• Can be re-used• For electrophoresis of small (<1kb) DNA• Better resolution of small (<1kb) DNA• Decreased DNA mobility• High ionic strength and high buffering capacity - recirculation may not be required for extended run times• Reacts with the agarose making smaller pores and a tighter matrix. This reduces broadening of the DNA bands for sharper resolution.

3. Sample Buffer

Samples are prepared and mixed with sample buffer before being applied to the prepared gel. Sample buffers contain similar components to the running buffer, dyes for visibility, and glycerol to provide weight to the samples. This increased sample density ensures samples load evenly into the wells and do not float out during loading. Dyes also migrate toward the anode end of the electrophoresis chamber at predictable rates allowing the gel run to be monitored.

4. DNA Markers

Markers are run on each gel to monitor sample separation and to provide an accurate size estimation of the samples. By running a known marker of a specific concentration, the amount of the DNA can be estimated. These size markers are a suitable restriction digest of commonly available DNA.

Section 6 Troubleshooting

Problem	Solution
Agarose leaks into chamber when pouring gel	Check to see if the gasket is firmly seated in the grooves on the ends of the UVT gel tray. Reseat gasket if necessary by removing and rinsing under warm running water, then reseat evenly in the tray groove.
Bands seem to be running at an angle.	Check to be sure the casting is being done on a level surface. A leveling platform may be required. Make sure the gel tray is pressed all the way down and rests level on the casting chamber platform (the bubble in the bubble level should rest in the center circle). Adjust the leveling screws to make the casting chamber (D4-CST) level.
Samples seem to be running unevenly in certain areas.	Check to be sure the platinum electrode wire is intact and running evenly across the base of the chamber and up the side to the junction of the banana plug. If there appears to be a break in the electrode connection contact Technical Services immediately. This problem may also be caused by regular casting with very hot agarose gel (>60°F) which may damage the gel tray over time. Always cool the melted agarose to below 60°F before casting to avoid warping the UVT gel tray. Warping the gel tray will cause all subsequent gels to be cast unevenly.
Samples do not band sharply and appear diffuse in the gel.	Gels should be no more than 5mm thick and allowed to solidify completely before running. For standard agarose, this would be about 30 minutes, if low melting point agarose is used, it may be necessary to completely solidify gels at a cooler temperature in the refrigerator or cold room. Gels should be submerged in 3-5mm of buffer to avoid gel dry out, but excess buffer >5mm can cause decreased DNA mobility and band distortion.
Samples are not moving as expected through the gel, remaining in the wells, running "backwards" or diffusing into the gel.	Check to be sure that a complete power circuit is achieved between the unit and the power supply. Platinum wire and banana plugs should be intact. To test, simply fill the unit with running buffer and attach to the power supply without a gel or gel tray in the unit. The platinum wires on both sides of the unit should produce small bubbles as the current passes through. If a complete circuit does not exist, there will be little to no bubbles. Contact Technical Services to schedule a repair. Samples that appear to run backwards through the gel is caused by the tray being placed in the chamber in the reverse direction. The tray should be placed in the chamber with the comb at the edge of the tray closest to the cathode side of the chamber.

Section 6
Troubleshooting

Problem	Solution
When the comb is removed from the gel, the sample well is ripped and damaged.	Always make sure to allow the gel to solidify completely before moving the tray, unit, or removing the comb. To avoid damage to the sample wells, gently rock the comb back and forth lightly to loosen, then slowly pull the comb straight up out of the gel tray. This rocking helps to avoid suction as the comb is removed.
The gel seems to run slower under usual running conditions.	The volume of running buffer used to submerge the gel should only be between 3-5mm over the gel surface. The gel should be completely submerged to avoid the gel from drying out, which can smear the bands and possibly melt the gel due to overheating. If excessive running buffer is added the mobility of the DNA decreases and band distortion may result. Excess buffer causes heat to build up and buffer condensation inside the unit may result.

Additional Sources for Reference

Maniatis T., E. F. Fritsch and J. Sambrook. *Molecular Cloning: A Laboratory Manual*, Cold Spring Harbor Laboratory, Cold Spring Harbor, NY.

Short Protocols in Molecular Biology, - A Compendium of Methods from Current Protocols in Molecular Biology, Edited by Fredrick M. Ausubel, et. al.

Adams, D., and R. Ogden, Electrophoresis in Agarose and Acrylamide Gels, *Methods in Enzymology*, Vol. 152 (1987) Academic Press, Inc.

Fotador, U.. *Simultaneous Use of Standard and Low-Melting Agarose for the Separation and Isolation of DNA by Electrophoresis*, BioTechniques, Vol. 10, No. 2, (1991)

Boots, S. *Gel Electrophoresis of DNA* ; Analytical Chemistry, Vol. 61, No. 8, April 15, 1989

Section 7 Specifications

Recommended Running Conditions

Model	D3-14	D2
Gel Size (W x L in cm)23 x 14	14.4 x 10.2
Buffer Capacity (ml)800ml	600ml
Voltage Requirements (V)20-150	20-150
Time Requirements (min)30-60	30-60

Migration Distance

The charts below give the migration distance for each comb slot on the gel tray with the run lengths.

Figure 7-1. D3-14 Migration Distance

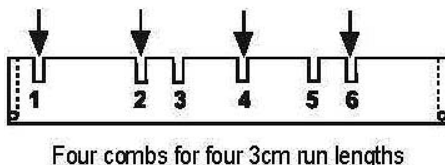
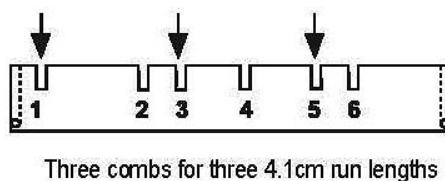
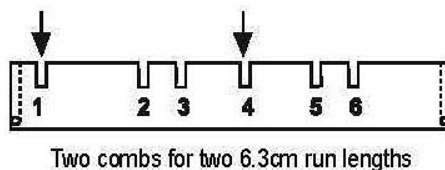
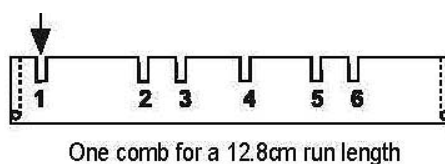
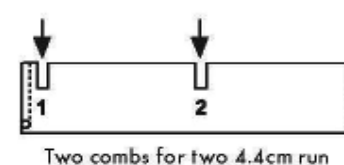
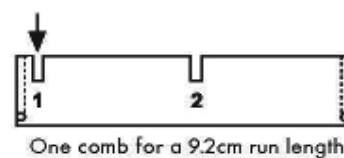

Figure 7-2. D2 Migration Distance



Section 8 Optional Equipment

Buffer Exchange Port Option, D4-BP

The buffer exchange port option is used to recirculate the buffer during extended gel runs. Recirculation is used to prevent buffer depletion of certain low ionic running buffers, for extended runs multiple sample sets, or for RNA gels. If your unit has the buffer exchange port option, it will be fitted with two white buffer port terminals (Figure 8-1) and will contain two separate port inserts packaged in a small plastic bag located inside the unit upon arrival.



Figure 8-1. Port Insert

How these work...

The inserts are pushed into the attached ports on the side wall of the unit with the black O-ring side facing in. The insert will “snap” into place in the port in the “open” position and is ready to circulate buffer. Appropriate tubing is then connected to the small outer ringed ends of the ports for circulation using a separate recirculator or peristaltic pump. To close the port, which also releases the insert, simply press the flat metal button and the insert detaches. The port is now in the “closed” position.

Note. Buffer may also be passed through a heat exchanger. ▲

Table 8-1. Comb Options for Models D2 and D3-14

Catalog No.	Comb Type	No. of Teeth	Thickness of Teeth	Width of Teeth	Recommended Loading Volumes ¹			
					0.25cm ²	0.5cm ²	0.75cm ²	
D1-10C	Standard	10	1.0mm	12.2mm	9µl	32µl	55µl	78µl
D1-10D	Standard	10	1.5	12.2	14	48	82	117
D1-20C	Standard	20	1.0	5.2	4	14	23	33
D1-20D	Standard	20	1.5	5.2	6	20	35	50
D1-30C ³	Micro Well	30 (2x) ³	1.0	7.2	2	19	32	46
D1-30D ³	Micro Well	30 (2x) ³	1.5	7.2	3	28	49	69
D1-40C	Standard	40	1.0	1.7	1	4	8	11
D1-40D	Standard	40	1.5	1.7	2	7	11	16
D1-MTC ³	Micro Well	15 (1x) ³	1.0	7.2	5	19	32	46
D1-MTD ³	Micro Well	15(1X) ³	1.5	7.2	8	28	49	69
D2-RL-9C ³	Rapid Load	9(1X)	1.0	7.2	5	19	32	46
D2-RL-9D ³	Rapid Load	9(1X)	1.5	7.2	8	28	48	69
D2-RL-25C ³	Rapid Load	25(2X)	1.0	2.5	2	7	12	17
D2-RL-25D ³	Rapid Load	25(2X)	1.5	2.5	3	11	18	26

1 Loading Volume is calculated as 75% of total well volume (TxWxHx0.75)

2 Gel Thickness

3 8 & 12 Channel Pipette Format

Table 8-2. Comb Options for Model D3-14

Catalog No.	Comb Type	No. of Teeth	Thickness of Teeth	Width of Teeth	Recommended Loading Volumes ¹			
					0.25cm ²	0.5cm ²	0.75cm ²	1.0cm ²
D3-MTC ³	Micro Well	25(1X) ³	1.0	7.5mm	6µl	20µl	34µl	48µl
D3-MTD ³	Micro Well	25 (1X) ³	1.5	7.5	8	30	51	72
D3-MT2C ³	Micro Well	50 (2X) ³	1.0	3	2	8	14	19
D3-MT2D ³	Micro Well	50 (2X) ³	1.5	3	3	12	20	29
D3-WALL	Wall	1		230				
XCM	Custom	1.0, 1.5, 2.0, 3.0						

1 Loading Volume is calculated as 75% of total well volume (TxWxHx0.75)

2 Gel Thickness

3 8 & 12 Channel Pipette Format

How to Determine Well Sample Volume

Hg = height of gel used

Hs = height of well used for sample volume

Hw = well height

There are two volumes to consider when determining the sample volume for a horizontal gel.

Gel Volume which is Width x Length x Gel Height and uses centimeters.

Sample Volume which is Tooth Width x Comb Thickness x Apparent Well Height, and uses millimeters.

Gel Height is generally set to a height between 0.5 cm and 0.75 cm. Therefore, once you choose the height, the volume is the gel dimensions (given in the catalog for each gel box, I.D.) times this height.

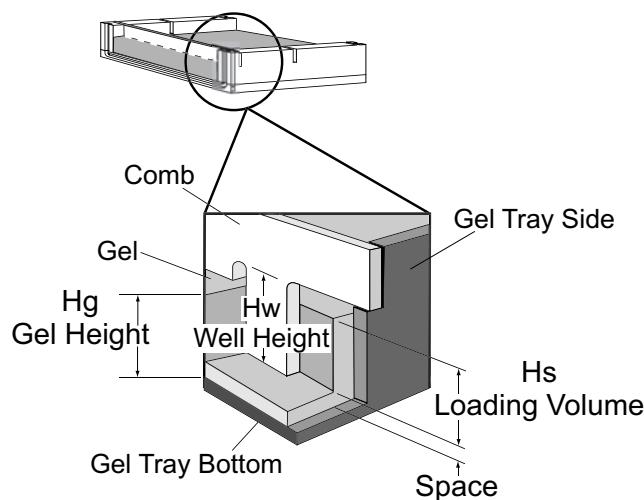

Figure 8-1. Determining Volume

Once the gel height (Hg) is chosen, the well volume and then the sample volume can be calculated.

The well height (Hw) is 1.5 mm less than the gel height:

$$Hw = \text{Gel Height} - 1.5 \text{ mm}$$

Using the well height, the volume of the well is calculated:

$$V_w = (\text{Well Height}) (\text{Tooth width} \times \text{comb thickness}).$$

The loading volume is a 0.75 safety factor applied to the well volume:

$$V_s = (V_w) (.75).$$

For Owl Combs, there are only two thicknesses; 1.0mm and 1.5mm. This is the depth. The width of the well is determined by the number of teeth. For a given gel box, as the number of teeth increase, the volume of each tooth decreases.

THERMO FISHER SCIENTIFIC OWL PRODUCTS WARRANTY USA

The Warranty Period starts two weeks from the date your equipment is shipped from our facility. This allows shipping time so the warranty will go into effect at approximately the same time your equipment is delivered. The warranty protection extends to any subsequent owner.

During the first thirty-six (36) months, component parts proven to be non-conforming in material or workmanship will be replaced at Thermo's expense, including labor. Installation, calibration and certification is not covered by this warranty agreement. The Technical Services Department must be contacted for warranty determination and direction prior to performance of any repairs. Expendable items, glass, filters and gaskets are excluded from this warranty.

Replacement or repair of component parts or equipment under this warranty shall not extend the warranty to either the equipment or to the component part beyond the original warranty period. The Technical Services Department must give prior approval for return of any component or equipment. At Thermo's option, all non-conforming parts must be returned to Thermo postage paid and replacement parts are shipped FOB destination.

THIS WARRANTY IS EXCLUSIVE AND IN LIEU OF ALL OTHER WARRANTIES, WHETHER WRITTEN, ORAL, OR IMPLIED. NO WARRANTIES OF MERCHANTABILITY OR FITNESS FOR A PARTICULAR PURPOSE SHALL APPLY.
Thermo shall not be liable for any indirect or consequential damages including, without limitation, damages to lost profits or loss of products.

Your local Thermo Sales Office is ready to help with comprehensive site preparation information before your equipment arrives. Printed instruction manuals carefully detail equipment installation, operation and preventive maintenance.

If equipment service is required, please call your Technical Services Department at 1-800-438-4851 (USA and Canada) or 1-740-373-4763. We're ready to answer your questions on equipment warranty, operation, maintenance, service, and special applications. Outside the USA, contract your local distributor for warranty information.



Rev. 0 9/12

THERMO FISHER SCIENTIFIC OWL PRODUCTS WARRANTY INTERNATIONAL

The Warranty Period starts two months from the date your equipment is shipped from our facility. This allows shipping time so the warranty will go into effect at approximately the same time your equipment is delivered. The warranty protection extends to any subsequent owner.

During the first thirty six (36) months, component parts proven to be non-conforming in material or workmanship will be replaced at Thermo's expense, excepting labor. Installation, calibration and certification is not covered by this warranty agreement. The Technical Services Department must be contacted for warranty determination and direction prior to performance of any repairs. Expendable items, glass, filters and gaskets are excluded from this warranty.

Replacement or repair of component parts or equipment under this warranty shall not extend the warranty to either the equipment or to the component part beyond the original warranty period. The Technical Services Department must give prior approval for return of any component or equipment. At Thermo's option, all non-conforming parts must be returned to Thermo postage paid and replacement parts are shipped FOB destination.

THIS WARRANTY IS EXCLUSIVE AND IN LIEU OF ALL OTHER WARRANTIES, WHETHER WRITTEN, ORAL, OR IMPLIED. NO WARRANTIES OF MERCHANTABILITY OR FITNESS FOR A PARTICULAR PURPOSE SHALL APPLY. Thermo shall not be liable for any indirect or consequential damages including, without limitation, damages to lost profits or loss of products.

Your local Thermo Sales Office is ready to help with comprehensive site preparation information before your equipment arrives. Printed instruction manuals carefully detail equipment installation, operation and preventive maintenance.

If equipment service is required, please call your Technical Services Department at 1-800-438-4851 (USA or Canada) or 1-740-373-4763. We're ready to answer your questions on equipment warranty, operation, maintenance, service, and special applications. Outside the USA, contract your local distributor for warranty information.



Rev. 0 9/12

Thermo Fisher Scientific
401 Millcreek Road
Marietta, Ohio 45750
United States

www.thermofisher.com

ThermoFisher
S C I E N T I F I C