

IN5122/IN5124

Instant Stack Guide

Guide d'empilement rapide

Schnellstapelanleitung

Guía de apilamiento instantáneo

Guida allo stack istantaneo

Overlap Handleiding

Guia de Empilhamento Instantâneo

即时堆叠指南

가이드를 스택 인스턴트

Guide för stapling

Руководство по мгновенному стеку

Regulatory models: W60, W61

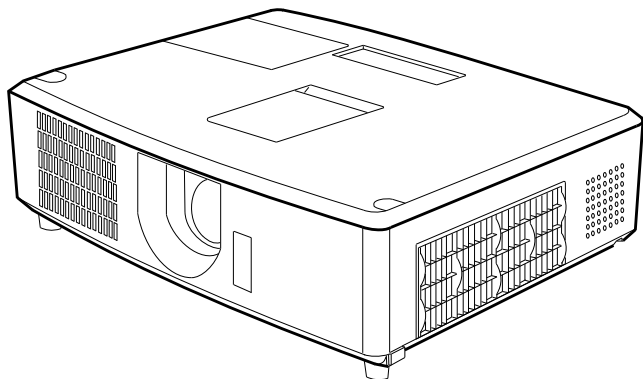

010-0762-00

DISPERINDAG No. 0287/1.824.51/09.03

InFocus

Bright Ideas Made Brilliant

This page left blank intentionally

Projector

IN5122/IN5124 Instant Stack Guide

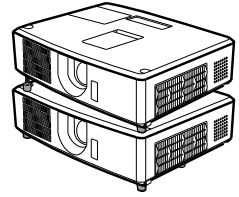

Thank you for purchasing this product.

This manual only explains the Instant Stack feature. If you need other information, please see the other product manuals.

Features

This IN5122/IN5124 projector can be used with another IN5122/IN5124 projector to project an image on the same screen using the Instant Stack feature.

Both projectors can be operated simultaneously to make the image brighter.

Moreover, if you connect both projectors with an RS232 cross-over cable, it becomes a smart stacking system. Both projectors can also work separately, so that if one projector fails, the other will start displaying your presentation automatically. This Instant Stack feature provides great installation flexibility.

⚠WARNING ► Before using this product, read all the product manuals. After reading them, store them in a safe place for future reference.

► Follow all the instructions in the manuals and on the product. The manufacturer assumes no responsibility for damage caused by mishandling that is beyond normal usage as defined in these manuals.

NOTES • The information in this manual is subject to change without notice.

- The manufacturer assumes no responsibility for any errors that may appear in this manual.
- The reproduction, transfer or copy of all or any part of this document is not permitted without express written consent.

Trademark acknowledgment

All the trademarks in this manual are the properties of their respective owners.

Contents

1. Introduction	3	3. STACK menu settings	17
1.1 Entries and graphical symbols explanation	3	3.1 Displaying the STACK menu	17
1.2 Important safety instruction	3	3.2 Selecting Main, Sub or off	18
Instant Stack feature	3	3.3 Selecting lamp operation mode ..	19
General installation	5	3.4 Selecting lamp switching mode ..	21
1.3 Basic information and preparation	6	3.5 Selecting the Sub input source...	22
Instant Stack	6	3.6 Saving Smart Stack settings.....	23
Smart Stack and Simple Stack	6	STACK menu	23
Smart Stack and Simple Stack Remote Control.....	6	STACK menu dialogs.....	23
Installation options	6	3.7 Important information for Smart Stack.....	24
Temporary terms for both projectors....	6	4. Connecting cables	27
2. Installation	7	4.1 Connecting an RS232 cable.....	27
2.1 Smart Stack preparation.....	7	4.2 Connecting signal cables.....	28
2.2 Installing the first projector (Projector A)	8	Inputting the image from Main to Sub	28
Preparing the elevator feet	8	Inputting the image to Sub and Main separately.....	28
Deciding on the installation position	8	5. Setting input ports using menu.....	29
Setting up Projector A	9	5.1 Preparing for menu operation.....	29
2.3 Installing the second projector (Projector B)	11	5.2 Checking the Main projector's operating status	29
Stacking the projectors	11	5.3 Starting the Main projector	30
Connecting projectors.....	11	5.4 Setting the Source Inputs	31
Setting up Projector B	12	Inputting an image from Main to Sub - Computer signal	31
2.4 Confirming Main and Sub settings.....	14	Inputting an image from Main to Sub - Video signal (either component or video)	32
2.5 Fine adjustment of the image position	15	Inputting an image to Sub and Main separately.....	32
For Smart Stack users	15	6. Scheduling Limitations	34
For Simple Stack users.....	16	7. Troubleshooting	36

1. Introduction

1.1 Entries and graphical symbols explanation

The following entries and graphical symbols are used for this manual and the product as follows, for safety purposes. Please review and heed this information.

- ⚠️ **WARNING** This entry warns of a risk of serious personal injury or even death.
- ⚠️ **CAUTION** This entry warns of a risk of personal injury or physical damage.
- 📌 **NOTICE** This entry indicates fear of causing trouble.

1.2 Important safety instructions

Following are important safety instructions for using this product in an Instant Stack application. Read this information carefully and always follow these guidelines when using this product in an Instant Stack application.

Instant Stack feature

⚠️ **WARNING** ► Do not allow the stacked projectors to fall.

- When stacking two projectors, make sure the elevator feet and heel of the upper projector are inserted securely into the corresponding pockets of the lower projector. (📖11)
- When using two projectors in an Instant Stack application, you can change the projection angle of the stacked projectors by adjusting the elevator feet of the lower projector. (📖8) Prevent the stacked projectors from falling off or tipping over when adjusting the elevator feet.
- A maximum of two projectors can be stacked. Do not stack three or more projectors.
- Stacked projectors (which are using the stack pockets, elevator feet and heel of the lower projector) should never be installed in a place higher than the person's height.
- Do not install stacked projectors (which are using the stack pockets, elevator feet and heel of the lower projector) in a ceiling mount application.
- Do not touch the stacked projectors unless otherwise instructed by this manual. Do not hit the projectors with any type of object.

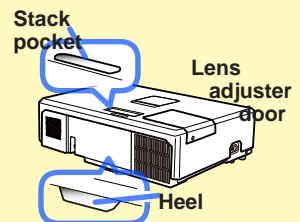
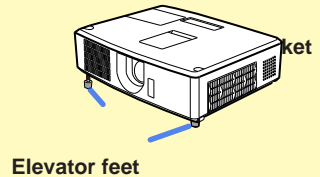

(continued on next page)

1.2 Important safety instructions (continued)

NOTICE ► Instant Stack allows you to stack two projectors or arrange them side-by-side easily. Depending on the installation and surrounding environment, images projected from both projectors may not superimpose perfectly. The images cannot superimpose well when the screen is slanted, warped or has an uneven surface.

- Images projected immediately after turning on the projectors are unstable due to rising internal temperatures. Wait at least 20 minutes before beginning to adjust the superimposed images.
- Image positions may shift due to temperature change, vibration, or shock caused by a projector impact. Install the projectors in a stable environment when using Instant Stack. If the image positions shift, re-adjust the images. (📖9, 12, 15)
- The image positions may shift over time due to the tension and the weight of connecting cables. Make sure not to impose any load on the projectors when arranging the cables.
- If the volume level of the built-in speakers is too high, both projectors may resonate, noise may occur and the image quality may deteriorate. In this case, check the volume setting on both projectors. Lower the volume until the symptoms disappear or arrange the projectors side-by-side.
- When two projectors are connected using an RS232 cable, the Main projector will be able to control the Sub projector. This feature is known as Smart Stack. (📖11) When Smart Stack is used with an RS232 cable, RS232 communication cannot be used to control the projectors. If you wish to control the projectors, use either of the projector's LAN connections.
- When Smart Stack is used, some function operations and settings are unavailable. Refer to this manual for details. (📖34)

General installation

⚠WARNING ▶ Install the projectors where you can access the power outlet easily.

- ▶ Do not subject the projectors to unstable conditions. Install the projectors in a stable horizontal position.
- ▶ Do not use any mounting accessories except the accessories specified by the manufacturer. Read and keep all the manuals for accessories which are used.
- ▶ For special installations, such as ceiling mounting, be sure to consult with your dealer beforehand. Specific mounting accessories and services may be required.
- ▶ Do not install the projector near thermally conductive or flammable items.
- ▶ Do not place the projector in a place where it may get wet.

⚠CAUTION ▶ Place the projectors in a cool place with sufficient ventilation.

- Keep a space of 11.8" (30 cm) or more between the sides of the projectors and other objects such as a wall. If you install two projectors side-by-side (Option 2  6), keep a space of 11.8" (30 cm) or more between both projectors.
- Do not impede, block or cover the projectors' vent holes.
- Do not put the projectors in places which are exposed to magnetic fields. Doing so can cause the cooling fans inside the projector to malfunction.
- ▶ Avoid placing the projectors in smoky, humid or dusty places.
- Do not place the projectors near humidifiers. Humidifiers (particularly ultrasonic humidifiers) cause chlorine and minerals contained in tap water to be atomized. These minerals can enter the projectors and cause image degradation and other problems.

NOTICE ▶ Position the projectors to prevent light from directly hitting the projector's remote sensor.

- Do not place the products in a place where radio interference can occur.

1.3 Basic information and preparation

Instant Stack

Instant Stack allows you to superimpose images projected from two projectors easily. This projector is designed with Instant Stack capabilities to install two projectors and superimpose their images.

Smart Stack and Simple Stack

Instant Stack includes the following two features.

When two projectors are connected via an RS232 cable with necessary settings performed on the projectors, these two projectors will automatically operate in synchronization with each other according to the settings. This is known as Smart Stack in this manual.

Both projectors can operate separately without an RS232 connection. This is known as Simple Stack in this manual.

Remote control for Smart Stack and Simple Stack

For Smart Stack, one projector must be defined as the Main projector and the other must be defined as the Sub Projector. (📖 18) Only the Main projector is capable of receiving remote control signals. To operate the Sub projector, you need to point the remote control at the Main projector.

For Simple Stack, both projectors can receive remote control signals. To avoid crosstalk when operating with the remote control, it is recommended that you operate one projector with the remote control and the other with either the projector's control panel or a wired remote control.

Installation options

Following are two options to install the projectors. Instant Stack supports both options.

Option 1 : Stack vertically

Option 2 : Arrange side-by-side

This manual primarily describes vertically stacked projectors (**Option 1**). If you wish to install two projectors side-by-side (**Option 2**), refer to the descriptions in this manual.

Temporary terms for both projectors

To help you better understand the stacking arrangement of each projector, these terms will be periodically used to reference the projectors:

Projector A : Projector placed underneath

Projector B : Projector placed on top of **Projector A**

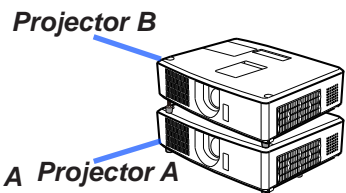

2. Installation

For safety reasons, read [1.2 Important safety instructions](#) (📖3-5) carefully before installation. In addition, review the following for proper use of Instant Stack.

- When using Smart Stack, both projectors will respond to remote control signals until the STACK MODE on either projector is set to SUB.
During installation, we recommend you operate one projector with the remote control and the other with the projector control panel or a wired remote control.
- Images from **Projector A** and **Projector B** may superimpose well initially but shift over time. Re-adjust the images as needed.
- If the volume level of the built-in speakers is too high, both projectors may resonate, noise may occur and image quality may deteriorate.
In this case, check the volume setting on both projectors. Lower the volume until the symptoms disappear or arrange the projectors side-by-side. If the image positions are shifted, re-adjust.

2.1 Smart Stack Preparation

When using Smart Stack via an RS232 connection, you must set up both projectors according to the following settings. Otherwise, the Smart Stack menu will not be available.

- POWER SAVING MODE in SETUP menu: ENABLE
(📖[User's Manual](#) → [SETUP menu](#))
- COMMUNICATION TYPE under COMMUNICATION in SERVICE menu: OFF
(📖[User's Manual](#) → [OPTION menu](#))
- STACK LOCK in SECURITY menu: OFF

When STACK LOCK is set to on, menus related to Instant Stack cannot be operated. Therefore it is necessary to set it to off during installation and menu settings.

(1) Use the ▲/▼/◀/▶ buttons to go into the following menu.

ADVANCED MENU > SECURITY
> STACK LOCK

STACK LOCK dialog will appear on screen. (📖[User's Manual](#) → [SECURITY menu](#))

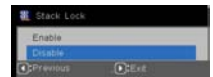

(2) Use the ▲/▼ buttons to highlight OFF, and press the ▶ button to save the change.

2.2 Installing the first projector (*Projector A*)

Preparing the elevator feet

When stacking both projectors, minimize the length of the elevator feet using the elevator buttons on ***Projector A*** and ***B***.

⚠ **CAUTION** ▶ Be careful when stacking both projectors. The projector on top may slide off.

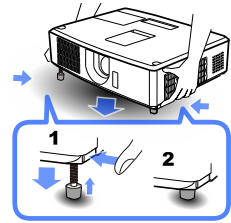

Deciding on the installation position

Decide the position of ***Projector A*** and its projection angle. ([📖 Quick Start Guide](#) → [Arrangement](#) and [Adjusting the projector's elevator](#))

NOTE • Set the tilt angle of ***Projector A*** to within 12 degrees from the level line.

- Follow these recommendations when installing.
 - Set the **VERTICAL** adjuster to its upper-most position.
 - Do not set the **ZOOM** ring to its widest position.
 - Set the **HORIZONTAL** adjuster near its center position.

Setting up **Projector A**

1. Turn on **Projector A**.
2. Use the **VERTICAL** adjuster to set the lens to its upper-most position.

NOTES • If the lens is not at its upper-most position, **Projector B's** image may not superimpose well onto **Projector A's** image.

- Choose CEILING and REAR settings first as needed as it may change the image position. ([📖 User's Manual](#) → [SETUP menu](#))
- Set the **HORIZONTAL** adjuster near its center position.

3. Adjust the **Projector A** image to fit the screen using the **VERTICAL** and **HORIZONTAL** adjusters, and the **ZOOM** and **FOCUS** rings. ([📖 Quick Start Guide](#) → [Displaying the picture](#))
Adjust the image position using KEYSTONE and CORNER CORRECTION as needed. ([📖 User's Manual](#) → [BASIC MENU](#) or [SETUP menu](#))

NOTES • Do not adjust the **ZOOM** ring to its widest position, otherwise **Projector B's** image may not superimpose well onto **Projector A's** image. Adjusting **Projector B's** image position electronically does not increase its image size. Use the **ZOOM** ring to adjust **Projector B's** image size slightly larger than **Projector A's**.

- KEYSTONE cannot be operated when CORNER CORRECTION is in use. To adjust the image using both KEYSTONE and CORNER CORRECTION, adjust KEYSTONE first.
- If you are using a Simple Stack, go to [2.3 Installation of the second projector \(Projector B\)](#). ([📖 11](#))

4. Display the menu with the **MENU** button. ([📖 User's Manual](#) → [Using the menu function](#))
5. Use the **▲/▼/◀/▶** buttons to go into the following menu.

ADVANCED MENU > OPTION
> SERVICE > COMMUNICATION
> STACK

The STACK menu will appear on screen.
([📖 User's Manual](#) → [OPTION menu](#))

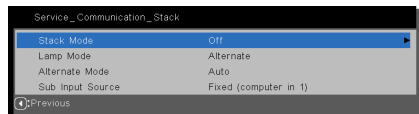

(continued on next page)

2.2 Installing the first projector (Projector A) - Setting up Projector A (continued)

6. Use the ▲/▼ buttons to highlight STACK MODE, and press the ► button to display the STACK MODE dialog. Highlight SUB pressing the ▲/▼ buttons, and press the ► button.
7. After pressing the ► button, a dialog will appear asking you to confirm the settings. Press the ► button to save the settings.
(📖23)

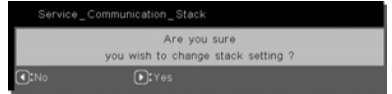

2.3 Installing the second projector (**Projector B**)

Stacking the projectors

1. Place **Projector B** on **Projector A** when stacking both projectors. Make sure the heel on the bottom of **Projector B** is inserted into the corresponding pocket on the top of **Projector A**.
2. With **Projector B** placed on **Projector A**, push **Projector B's** elevator feet to extend the elevator feet without lifting **Projector B**. Make sure the elevator feet reach the bottom of the stack pockets on **Projector A**.

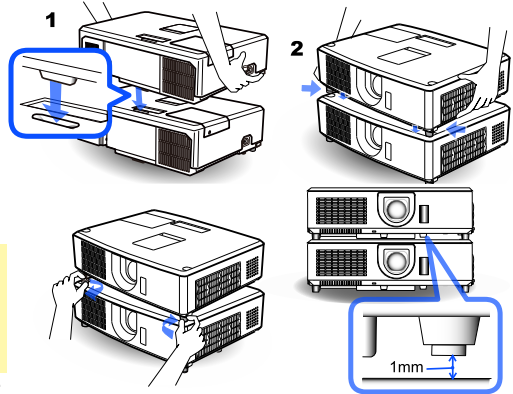

CAUTION ▶ Be careful when stacking both projectors, the projector on top may slide off.

3. Rotate **Projector B's** elevator feet counterclockwise twice and leave a ~1mm gap between the protrusion at the bottom of **Projector B** and the top of **Projector A** as shown in the figure.

NOTES

- You must keep **Projector B** slightly away from **Projector A** except for the heel portion to prevent both projectors from resonating due to the sound output from the built-in speakers.
- If **Projector B** is tilted any farther, **Projector B's** image may not superimpose onto **Projector A's** image.
- If **Projector A's** elevator feet are used, make sure the tilt angle for both projector is no greater than 12 degrees from level.

Connecting projectors

To use Smart Stack, connect an RS232 cross cable between the **CONTROL** ports of **Projector A** and **Projector B**.

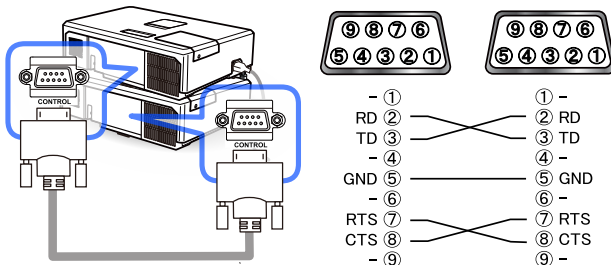

Setting up **Projector B**

1. Turn on **Projector B**.

NOTE • After turning on **Projector B**, make sure **Projector B's** image is not significantly tilted compared to **Projector A's** image. If the image is overly tilted, rotate **Projector B's** elevator feet to adjust the angle so that the tilt is approximately correct. Verify that there is a gap of about 1 mm between the protrusion at the bottom of **Projector B** and the top of **Projector A**.

2. Reset the adjustment of KEYSTONE and CORNER CORRECTION on **Projector B**. ([📖 User's Manual](#) → [BASIC MENU](#) or [SETUP menu](#))

NOTES • KEYSTONE cannot be operated when CORNER CORRECTION is in use. To reset both functions, reset CORNER CORRECTION first.

- Choose CEILING and REAR settings first, if needed, as they may affect the image position. ([📖 User's Manual](#) → [SETUP menu](#))

3. Adjust **Projector B's** image size and position using the **ZOOM** ring, **VERTICAL** and **HORIZONTAL** adjusters, and **FOCUS** ring until the images superimpose well.

NOTES • Adjusting the image size and position afterwards with features such as KEYSTONE and CORNER CORRECTION does not increase the image size. Therefore it is important that both images completely overlap.

- When controlling **Projector B** with the remote control, **Projector A** may also respond to the remote control. We recommend you control **Projector B** with its control panel.
- When both projectors are arranged side-by-side, adjust **Projector B's** image to superimpose onto the image of **Projector A**.
- If you are using Simple Stack, go to [For Simple Stack users](#). ([📖16](#))

4. Display the menu with the **MENU** button. ([📖 User's Manual](#) → [Using the menu function](#))

5. Use the **▲/▼/◀/▶** buttons to go into the following menu.

ADVANCED MENU > OPTION
 > SERVICE > COMMUNICATION
 > STACK

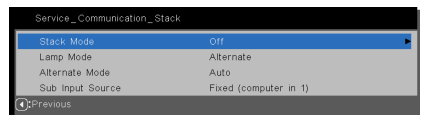

The STACK menu will appear on screen. ([📖 User's Manual](#) → [OPTION menu](#))

2.3 Installing the second projector (Projector B) - Setting up Projector B (continued)

6. Use the ▲/▼ buttons to highlight STACK MODE, and press the ► button to display the STACK MODE dialog.



Highlight MAIN with the ▲/▼ buttons, and press the ◀ button to return to the previous menu.

7. Use the ▲/▼ buttons to highlight LAMP MODE, and press the ► button to display the LAMP MODE dialog.



Highlight DUAL with the ▲/▼ buttons, and press the ► button.

8. After pressing the ► button, a dialog to confirm whether or not to save the setting is displayed.

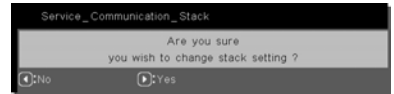

Press the ► button to save the change.

( 23)

2.4 Confirming Main and Sub settings

1. Press the **MENU** button on the remote control for Main (*Projector B*).

NOTE • When Smart Stack is in use, MAIN is only capable of receiving remote control signals. SUB will not respond to remote control signals.

2. The following dialogs appear on the lower right screen.



Main (*Projector B*)



Sub (*Projector A*)

3. If you press the ► button, the dialog closes and the Main (*Projector B*) menu will appear when MAIN is highlighted.
If you press the ◀ button, the dialog closes and the menu will disappear.

NOTE • If these dialogs do not display on screen, check the RS232 connection ([11](#)) and the MAIN or SUB setting in the STACK MODE dialog. ([18](#))

2.5 Fine adjustment of the image position

To superimpose the images of Main (**Projector B**) and Sub (**Projector A**), use CORNER CORRECTION to finely adjust the image size and position of Main (**Projector B**).

For Smart Stack users

1. Press the **MENU** button on the remote control or the control panel on Main (**Projector B**) to display the MENU dialog.

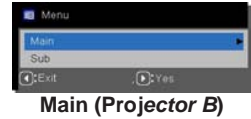

Highlight MAIN with the ▲/▼ buttons, and press the ► button.

The Main (**Projector B**) menu will appear.

2. Using the ▲/▼/◀/▶ buttons on the remote control or the control panel on Main (**Projector B**), select CORNER CORRECTION from the BASIC MENU, or the SETUP menu of ADVANCED MENU. ([User's Manual](#) → [BASIC MENU](#) or [SETUP menu](#))



Image from Main (Projector B)

The image for Smart Stack appears on screen. This image includes a RULED LINES screen with the CORNER CORRECTION dialog from Main (**Projector B**) and another RULED LINES screen from Sub (**Projector A**).

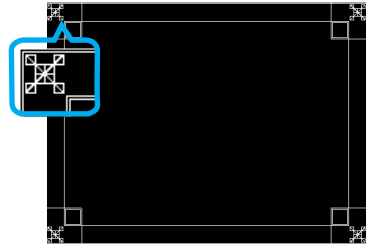

Image from Sub (Projector A)

3. Using CORNER CORRECTION on Main (**Projector B**), adjust the image size and position of Main (**Projector B**) to superimpose well onto the image of Sub (**Projector A**). ([User's Manual](#) → [BASIC MENU](#) or [SETUP menu](#))

The following is the recommended adjustment method.

- (1) Roughly adjust the four corners in the following order:

Top left → Top right
→ Bottom right → Bottom left

- (2) Finely adjust the four corners in the same order as listed above in Step 1.

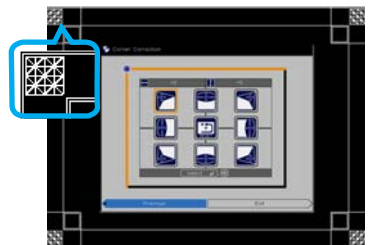

Superimposed image

NOTE • Refer to [NOTES for all users](#). ([User's Manual](#) 16)

For Simple Stack users

1. Press the **MENU** button on the remote control to display **Projector A's** menu.
2. Use the **▲/▼/◀/▶** buttons to open the RULED LINES dialog, then select STACK on the dialog. ([User's Manual](#) → [SCREEN menu](#))
3. Press the **MENU** button on **Projector B's** control panel to display the menu.

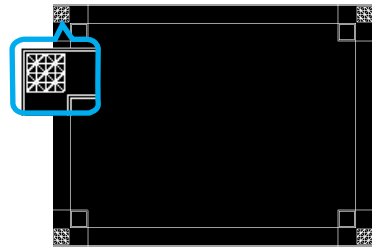

STACK of RULED LINES

4. Use the **▲/▼/◀/▶** buttons to select CORNER CORRECTION from BASIC MENU, or the SETUP menu of ADVANCED MENU. ([User's Manual](#) → [BASIC MENU](#) or [SETUP menu](#))

The CORNER CORRECTION dialog appears on screen.

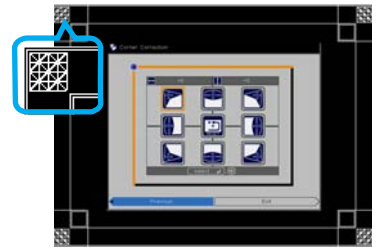

CORNER CORRECTION dialog on STACK of RULED LINES

5. Using CORNER CORRECTION on **Projector B**, adjust **Projector B's** image size and position to superimpose onto the **Projector A's** image. This is the recommended adjustment method:

(1) Roughly adjust the four corners in the following order:

Top left → Top right → Bottom right → Bottom left

(2) Finely adjust the four corners in the same order as listed above in Step 1.

NOTES for all users • For details on CORNER CORRECTION, refer to [CORNER CORRECTION](#) of [BASIC MENU](#) or [SETUP menu](#) in the [User's Manual](#).

- When arranging the projectors side-by-side (**Option 2**), it is necessary to adjust the image position of one projector in accordance with the other projector as explained above.
- Use a flat screen. If a curved or skewed screen is used, it is very difficult to align the two images even if you use the CORNER CORRECTION pin/barrel adjustment.
- Even after finely adjusting the images from both projectors, it may not be possible to completely superimpose the images depending on the input signals. In this case, try the following methods.
 - Press the **AUTO IMAGE** button on the remote control or perform AUTO IMAGE ([User's Manual](#) → [IMAGE menu](#)) on both projectors.
 - Adjust HORIZONTAL POSITION and VERTICAL POSITION ([User's Manual](#) → [IMAGE menu](#)) on both projectors.
 - Check the RESOLUTION setting in the INPUT menu of both projectors, and make certain that both the Main and Sub projector settings match. ([User's Manual](#) → [INPUT menu](#))

3. STACK menu settings

Set the Smart Stack operation using the STACK menu.

NOTES • If you are using Simple Stack without RS232 connection, skip this chapter.

- If you do not need to change the settings made during the installation explained prior to this chapter, go to [3.3 Selecting lamp operation mode](#). (📖19)
- Read [3.7 Important information for Smart Stack](#) carefully. (📖24)

3.1 Displaying STACK menu

Use the ▲/▼/◀/▶ buttons to go into the following menu.

ADVANCED MENU > OPTION

> SERVICE > COMMUNICATION > STACK

STACK menu will appear on screen. (📖 [User's Manual](#) → [OPTION menu](#)) The setting for Smart Stack operation starts from this menu.

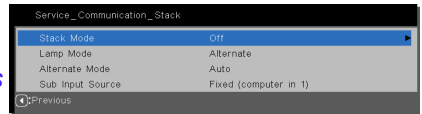

NOTE • Check that the following settings are made on both projectors. Otherwise, STACK menu on the projectors cannot be operated. (📖7)

- POWER SAVING MODE in SETUP menu: ENABLE (📖 [User's Manual](#) → [SETUP menu](#))
- COMMUNICATION TYPE under COMMUNICATION in SERVICE menu: OFF (📖 [User's Manual](#) → [OPTION menu](#))
- STACK LOCK in SECURITY menu: OFF (📖7)

3.2 Selecting Main, Sub or off

To enable Smart Stack, select either MAIN or SUB. Smart Stack starts when one projector is set to MAIN and the other is set to SUB in the STACK MODE dialog. To disable Smart Stack, select OFF.

1. Highlight STACK MODE in the STACK menu with the ▲/▼ buttons, then press the ► button to display the STACK MODE dialog.



2. Use the ▲/▼ buttons in the dialog to highlight MAIN, SUB or OFF.

OFF: Disables Smart Stack.

MAIN: Sets the projector to Main that functions as a control tower.

SUB: Sets the projector to Sub that functions as a follower.

3. Press the ◀ button to return to the previous menu, or press the ▶ button to save the change. (📖23)

3.3 Selecting the lamp operation mode

Select the DUAL or ALTERNATE lamp operation mode.

1. Highlight LAMP MODE in the STACK menu with the ▲/▼ buttons, then press the ► button to display the LAMP MODE dialog. 
2. Use the ▲/▼ buttons in the dialog to highlight DUAL or ALTERNATE.
DUAL: Turns on the projectors at the same time.
ALTERNATE: Turns on the projectors alternately.
3. Press the ◀ button to return to the previous menu, or press the ► button to save the change. (📖23)

NOTES • If DUAL is selected, a menu to select MAIN or SUB appears on screen when a button on the projector's control panel or remote control is pressed. Select the projector that you want to operate. Refer to the examples below.

- When the **MENU** button is pressed, a menu to select MAIN or SUB is displayed. If MAIN is selected, the Main projector's BASIC MENU or ADVANCED MENU is displayed.
- When the **KEYSTONE** button is pressed, a menu to select MAIN or SUB is displayed. If MAIN is selected, the Main projector's KEYSTONE menu is displayed.
- When LAMP MODE is set to DUAL, the following operating limitations will be in effect:
 - AUTO POWER and FREEZE functions on both projectors will be disabled.
 - The test patterns for CUSTOM of GAMMA and COLOR TEMPERATURE will not be displayed.
 - The projectors will take a slightly longer time to turn on. This is not a malfunction.

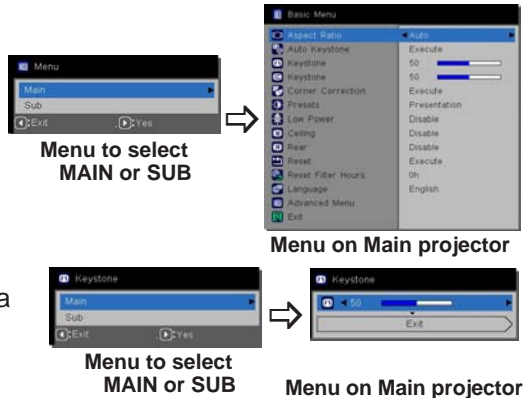

(continued on next page)

3.3 Selecting lamp operation mode (continued)

- NOTES • When LAMP MODE is set to DUAL, the images projected from the Main and Sub projectors may be different. To prevent this, we recommend you set the projectors as follows:
- Use the same image for RULED LINES and START UP LOGO on both projectors.
 - Capture the same image for SNAPSHOT on both projectors.
 - Save the same image on MY IMAGE on both projectors.
 - Use the same message content for the Messenger function ([📖 Network Guide](#) → [Messenger Function](#)) on both projectors.
- When LAMP MODE is set to DUAL, image shifts can result in image quality degradation on the screen. Choose CEILING and REAR settings before adjusting the image position because these settings will cause the image position to change. ([📖 User's Manual](#) → [SETUP menu](#))
 - When LAMP MODE is set to ALTERNATE and an error occurs while one of the projectors is in operation which causes the lamp to turn off, the other projector will automatically start to operate. However, if the RS232 cable is disconnected or AC power is not supplied, the other projector will not turn on.
 - If PIN LOCK or TRANSITION DETECTOR on both projectors is set to ON ([📖 User's Manual](#) → [SECURITY menu](#)), both projectors will not turn on even if ALTERNATE is selected. Enter the security code on both projectors and one of the projectors will turn on.
 - When Smart Stack is in use, the **POWER** indicator on the projector control panel will operate differently than normal. ([📖 User's Manual](#) → [Troubleshooting](#))
When the Main and Sub projectors are in standby mode, the Main projector determines which projector to turn on according to the STACK MODE setting if the **STANDBY/ON** button on the remote control or Main projector's control panel is pressed.
 - The Main projector **POWER** indicator will blink green while the Main projector determines which projector to turn on.
 - If the Main projector turns on, the Main projector **POWER** indicator will become steady green after lighting up, as it normally would.
 - If the Sub projector turns on, the Main projector **POWER** indicator will become steady orange after the Sub projector is turned on.
 - If an error occurs on the Main projector, the Sub projector turns on and the Main projector **POWER** indicator will become red (either solid or blinking).

3.4 Selecting the lamp switching mode

The following setting is necessary only when ALTERNATE is selected in the LAMP MODE dialog. (📖19) Select the AUTO or NORMAL lamp switching mode when using ALTERNATE.

1. Highlight ALTERNATE MODE in the STACK menu with the ▲/▼ buttons, then press the ► button to display the ALTERNATE MODE dialog. 
2. Use the ▲/▼ buttons in the dialog to highlight AUTO or NORMAL.

AUTO: Turns on the projector with the least lamp usage.

NORMAL: Turns on the projector that was not used the previous time.
3. Press the ◀ button to return to the previous menu, or press the ▶ button to save the change. (📖23)

NOTES • The ALTERNATE MODE dialog can be operated on the Main projector when ALTERNATE is selected in the LAMP MODE dialog.

- To maintain the quality and reliability of both projectors, the projector with the most lamp usage can turn on even if AUTO is selected.

3.5 Selecting Sub input source

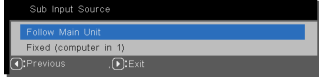
1. Highlight SUB INPUT SOURCE in the STACK menu with the ▲/▼ buttons, then press the ► button to display the SUB INPUT SOURCE dialog.
- 
2. Use the ▲/▼ buttons in the dialog to highlight FOLLOW MAIN UNIT or FIXED (COMPUTER IN 1).

FOLLOW MAIN UNIT: Causes the Sub projector to display the same source as the Main projector.

FIXED (COMPUTER IN 1): Sets the input source on the Sub projector to the **COMPUTER IN1** port which is connected to the **MONITOR OUT** port on the Main projector.
 3. Press the ◀ button to return to the previous menu, or press the ▶ button to save the setting changes. (📖23)

NOTES • If FIXED (COMPUTER IN 1) is selected, the Main projector's input source can be set to either the **COMPUTER IN1** or **IN2** port. When the **SOURCE** button on the remote control or the **SOURCE** button on the projector is pressed, the MAIN INPUT SOURCE dialog will be displayed on screen. Select COMPUTER IN 1 or COMPUTER IN 2 with the ▲/▼ buttons.

- If FIXED (COMPUTER IN 1) is selected, the **COMPUTER IN1** port on the Sub projector should be connected to the **MONITOR OUT** port on the Main projector with a computer cable. The image from the selected port is output from the Main projector's **MONITOR OUT** port to the Sub projector's **COMPUTER IN1** port. The MONITOR OUT DEFAULT setting on the Main projector is disabled when FIXED (COMPUTER IN 1) is selected. (📖[User's Manual](#) → [SETUP menu](#))

- If FIXED (COMPUTER IN 1) is selected, video signals can be input to the Main projector's **COMPUTER IN1** or **IN2** port. Set the port for video signal input in the COMPUTER IN menu and set the video format in the VIDEO STANDARD menu. Refer to [Inputting image from Main to Sub](#) (📖28) and [Inputting image from Main to Sub - Video signal \(either component or video\)](#). (📖32)

3.6 Saving Smart Stack settings

Before exiting the Smart Stack menu, we recommend you check all the settings in the STACK menu. When STACK menu dialogs are displayed, you can press the ◀ button to return to the STACK menu.

Follow these steps to exit the Smart Stack menu.

STACK menu

When you press the ◀ button (functions as a RETURN key) after making setting changes, a confirmation dialog will appear.

- Press the ▶ button (functions as a YES key) to save the setting and close the dialog. The screen becomes black while the setting is being applied. Please wait a few moments.
- Press the ◀ button (functions as a NO key) to return to the COMMUNICATION menu without saving the setting. ([User's Manual](#) → [OPTION menu](#) → [SERVICE](#))

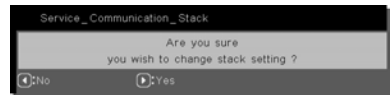
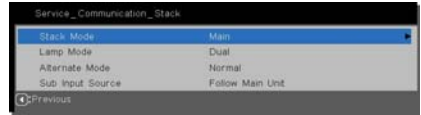

STACK menu dialogs

When you press the ▶ button (functions as a EXIT key) after making setting changes, a confirmation dialog will appear.

- Press the ▶ button (functions as a YES key) to save the setting and close the dialog. The screen becomes black while the setting is being applied. Please wait a few moments.
- Press the ◀ button (functions as a NO key) to close the dialog without saving the setting.

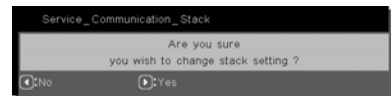

3.7 Important information for Smart Stack

This section provides important information on setting up the Main and Sub projectors, but not on menu operation. Read this information carefully.

- To use Smart Stack, one projector must be set to Main and the other set to Sub.
- When stacking both projectors, the control panel of the projector at the bottom of the stack cannot be operated. Therefore it is strongly recommended that the lower projector is set Sub and the projector on top is set to Main.
- All buttons except the **STANDBY/ON** button on the Sub projector's control panel are disabled. Operate the projectors with the Main projector's control panel or the remote control.
- Pressing the Sub projector's **STANDBY/ON** button does not allow you to turn off only the Sub projector. Both the Main and Sub projectors will turn off when the button is pressed for more than 3 seconds. Pressing the button also will not turn on either the Main or Sub projectors.
- The Main projector is capable of receiving remote control signals (not the Sub projector), so point the remote control at the Main projector.
- If a wired remote control is used, connect the cable to the Main projector instead of the Sub projector.
- For simple PC mouse and keyboard functions, connect both the Main and Sub projectors to your computer with USB cables. ([📖 User's Manual](#) → *Using as a simple PC mouse and keyboard*)
- AUTO SOURCE is disabled when the projector is used in a Smart Stack.
- Network communication and Web Control directly to the Sub projector cannot be used to turn on the Sub projector. The Sub projector can only be controlled through the Main projector.
- The Sub projector's remote control functions via Web Control will be disabled.
- If you try to turn on the projectors using the Power on and Display on feature on the Messenger function, the projectors will exit Smart Stack and display the specified message. To start Smart Stack again, re-select MAIN/SUB on both projectors in the STACK MODE dialog, or turn off and on both projectors again.
- The Main and Sub projectors share the following settings.
 - Muting feature ([📖 User's Manual](#) → *Temporarily muting the sound*)
 - ASPECT RATIO and OVERSCAN ([📖 User's Manual](#) → *IMAGE menu*)
 - COMPUTER IN ([📖 User's Manual](#) → *INPUT menu*)
 - DISPLAY MESSAGES ([📖 User's Manual](#) → *SCREEN menu*)
 - CUSTOM KEY ([📖 User's Manual](#) → *OPTION menu*)
 - RULED LINES ([📖 User's Manual](#) → *SCREEN menu*)
- The following functions are disabled.
 - Executing of AUTO KEYSTONE ([📖 User's Manual](#) → *SETUP menu*)
 - POWER SAVING MODE ([📖 User's Manual](#) → *SETUP menu*)
 - AUTO SOURCE ([📖 User's Manual](#) → *OPTION menu*)

(continued on next page)

3.7 Important information for Smart Stack (continued)

- Turning on/off AUTO KEYSTONE ([User's Manual](#) → *OPTION menu*)
 - AC POWER ON ([User's Manual](#) → *OPTION menu*)
 - POWER UP SOURCE ([User's Manual](#) → *OPTION menu*)
 - COMMUNICATION TYPE ([User's Manual](#) → *OPTION menu* → *SERVICE* → *COMMUNICATION*)
- The input source from the following ports cannot be selected:
 - **USB TYPE A, USB TYPE B, LAN**
 - When Smart Stack is in use, an error message will be displayed if an error occurs on any of the projectors.

When an error occurs, a full dialog will be displayed on screen. The full dialog changes to a small dialog after about 20 seconds without any key activity. While the small dialog is displayed, press the ◀ button to display a full dialog again.

The numbers “1” and “2” above the projector icons represent the Main and Sub projectors respectively.

Refer to the on-screen messages as shown below and take the necessary actions to resolve the problem.

Example:

Cover Error: The lamp cover is open.

Lamp Error: The lamp will not light up.

Fan Error: The cooling fan stopped functioning.

Temp Error: The projector's internal temperature is too high.

Air Flow Error: The projector's internal temperature is too high; verify that the exhaust vents are unblocked.

Filter Error: The filter timer exceeds the hours set in the FILTER MESSAGE menu. ([User's Manual](#) → *OPTION menu* → *SERVICE*)

Cold Error: The ambient temperature is too low.



Full dialog



Small dialog



3.7 Important information for Smart Stack (continued)

- If you need to turn a projector off to fix an issue, turn off both projectors, so that Smart Stack can be re-started properly.
- If both projectors have their PIN LOCK or TRANSITION DETECTOR security functions set to ON, both projectors will turn on. Enter the Main projector's security code first, followed by the Sub projector's. If the ALTERNATE mode is selected, one of the projectors will turn off automatically. ([📖 User's Manual](#) → [SECURITY menu](#))
- If only one of the projectors has their PIN LOCK or TRANSITION DETECTOR security function set to ON, the security code will need to be entered when turning on the projector.
 - In DUAL mode, both projectors will turn on. Enter the security code for the projector that is locked by the security function.
 - In ALTERNATE mode, if the projector locked by the security function is due to turn on according to the ALTERNATE mode setting, only that projector will turn on. Otherwise, both projectors will turn on. Enter the security code for the projector that is locked by the security function. After the security lock is released, one of the projectors will turn off (assuming that both turned on initially).

4. Connecting cables

To superimpose two images onto one screen, the same image must be input to both the Main and Sub projectors. There are various ways to do this. This chapter describes different ways to connect the cables. Read this chapter to find a method which meets your needs.

NOTES • If Simple Stack without an RS232 connection is used, the Main and Sub projectors described below do not exist. Simply think of Main as one projector and Sub as the other.

• For details on the input port specifications, refer to [Connecting with your devices](#) ([User's Manual](#) → [Setting up](#)) and [Connection to the ports.](#) ([RS232 Command and Control Manual](#))

4.1 Connecting an RS232 cable

If you are using Smart Stack, connect an RS232 cross cable between the RS232 ports on the Main and Sub projectors. ([11](#)) If you are using Simple Stack, an RS232 connection is not required.

NOTE • If the RS232 cable connecting both projectors operating in Smart Stack is disconnected, the projectors will exit Smart Stack and begin operating separately. Smart Stack will not restart when the cable is reconnected. To restart Smart Stack, follow the procedures below:

- (1) Do not operate the projectors for more than 10 seconds after disconnecting the cable to allow the projectors to recognize the disconnection of the cable.
- (2) Turn off both projectors and allow them to cool sufficiently.
- (3) Reconnect both projectors with the RS232 cable and turn them on again. Smart Stack will restart.

4.2 Connecting signal cables

There are two methods to input the image to the Sub projector. (22, 23)

- Input the image from the **MONITOR OUT** port on Main to Sub.
- Input the image to Sub and Main separately.

Input the image from Main to Sub

1. Connect the **MONITOR OUT** port on Main to the **COMPUTER IN1** port on Sub with a computer cable.
2. Connect the image output device to one of the input ports on Main.

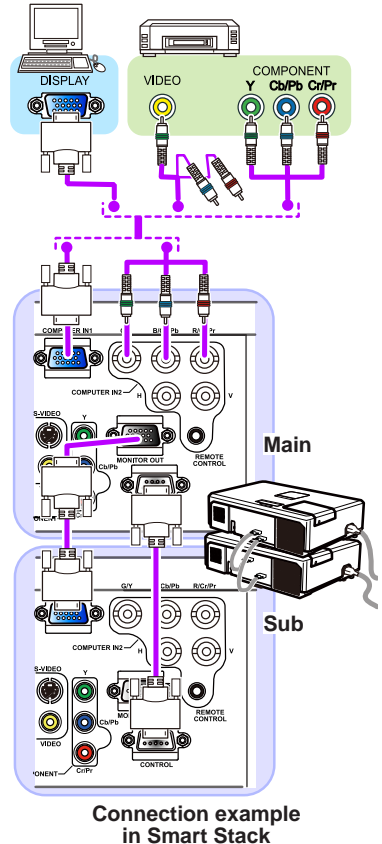

Smart Stack NOTES

- **COMPUTER IN1** and **IN2** can be used as the input port for the Main projector in Smart Stack. Do not use other ports for image input.
- You can input component signals to **COMPUTER IN1** and **IN2**.
- You can input video signals to the Y pin of the component video of **COMPUTER IN1** and **IN2**.

Simple Stack NOTES

- **COMPUTER IN1** and **IN2** can be used as the input port for the projector that is connected with a computer cable at its **MONITOR OUT** port. ([User's Manual](#) → **SETUP menu**) If you wish to use other input ports, input the image to Sub and Main separately.

Input the image to Sub and Main separately

1. Split the output signal from your image device into two with device such as a signal splitter.
2. Connect the output ports of the image output device to the same input ports on the Main and Sub projectors.

NOTES for Smart Stack • **LAN**, **USB TYPE A** and **USB TYPE B** cannot be used as the input ports on the Main projector in Smart Stack.

NOTES for Simple Stack • Any of the ports that is compatible with the signal can be used. Input the same signal to both projectors separately.

5. Setting input ports using menu

5.1 Preparing for menu operations

If Simple Stack without an RS232 connection is used, press the **SOURCE** button on the remote control or the control panel's **SOURCE** button to select the port to which the cable is connected. To set-up MONITOR OUT DEFAULT, refer to [SETUP menu](#) in [User's Manual](#).

If Smart Stack with the RS232 connection is used, all settings or modifications related to Smart Stack menu operations must be performed on the Main projector. The Main projector functions according to the Smart Stack input settings.

5.2 Checking the Main projector's operating status

For Smart Stack, all settings or modifications related to menu operations must be performed on the Main projector. Before operating the Smart Stack menu, verify that the Main projector is functioning.

1. Press the remote control's **MENU** button.
2. If the MENU dialog as shown on the right appears on the screen, both projectors are operating in DUAL mode and the Main projector is operating.



Go to [5.4 Setting the menu](#). (📖31)

If the dialog does not appear, LAMP MODE is set to ALTERNATE and one of the projectors is operating (but not both).

3. Use the ▲/▼/◀/▶ buttons to go into the following menu.

ADVANCED MENU > OPTION
> SERVICE > COMMUNICATION
> STACK

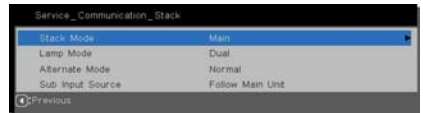

STACK menu will appear on screen.

(📖[User's Manual](#) → [OPTION menu](#))

4. Check the STACK MODE setting in the STACK menu.
 - If MAIN is displayed, the Main projector is operating. In this case, go to [5.4 Setting the menu](#). (📖31)
 - If SUB is displayed, the Main projector is turned off and the Sub projector is operating. In this case, go to [5.3 Starting up Main projector](#). (📖30)

5.3 Starting up the Main projector

After completing section [5.2 Checking Main projector's operating status](#), both projectors should be set to ALTERNATE mode and the Sub projector should be operating. Since the Smart Stack settings can only be changed when the Main projector is operating, this section explains how to switch from the Sub projector to the Main projector.

1. Use the ▲/▼/◀/▶ buttons to go into the following menu.

ADVANCED MENU > OPTION
> SERVICE > COMMUNICATION > STACK

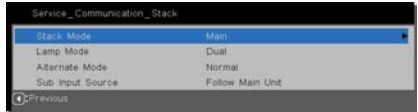

The STACK menu will appear on screen.

([User's Manual](#) → [OPTION menu](#))

2. Check the ALTERNATE MODE setting in the menu.

If NORMAL is displayed, both projectors will turn on alternately. Therefore, the Main projector will turn on when you restart the projectors.

- (1) Press the **STANDBY/ON** button on the remote control or Main projector's control panel to turn off the Sub projector.
- (2) After the projector has cooled down, press the **STANDBY/ON** button to turn on the projectors again. The Main projector will turn on.

If AUTO is displayed, the projector with the least lamp usage is turned on. Therefore, the Main projector may not be turned on even if you restart the projectors. Follow the procedures below to turn on the Main projector.

- (1) Use the ▲/▼ button to highlight STACK MODE, and press the ▶ button to display the STACK MODE dialog.
- (2) Use the ▲/▼ button to highlight OFF, and then press the ▶ button to save the change. ([23](#))
- (3) Repeat the above procedures to display the STACK MODE dialog again.
- (4) Use the ▲/▼ button to highlight SUB, and then press the ▶ button to save the change. ([23](#))
- (5) After exiting the menu, wait for 10 seconds or more.
- (6) Press the **STANDBY/ON** button on the remote control or Main projector's control panel, the Sub projector will turn off.
- (7) After the projector has cooled down, press the **STANDBY/ON** button to turn on the projectors again. The Main projector will turn on even if LAMP MODE has been set to AUTO.

3. You can change the settings for Smart Stack now that the Main projector is operating. Go to [5.4 Setting the menu](#). ([31](#))

NOTE • If the Main projector cannot be turned on due to an error or other issues, the Sub projector will turn on even if you follow the procedures above. Take the necessary actions to fix the Main projector, and then change the settings for Smart Stack.

5.4 Setting the Source Inputs

If Smart Stack is used with an RS232 connection, review the following. When inputting image signals to Sub via Main, the operations differ depending on whether computer signals or video signals (e.g. component, S-video, composite) are being used.

Inputting an image from Main to Sub - Computer signal

1. If the STACK menu is already displayed on the screen, proceed to step 3 below. Otherwise press the **MENU** button on the remote control.

If the MENU dialog is displayed, use the ▲/▼ buttons to highlight MAIN, and press the ► button. A menu will be displayed.



If the MENU dialog is not displayed, the STACK menu will appear.

2. Use the ▲/▼/◀/▶ buttons to go into the following menu.

ADVANCED MENU > OPTION
> SERVICE > COMMUNICATION > STACK



The STACK menu will appear on screen.

([User's Manual](#) → [OPTION menu](#))

3. Use the ▲/▼ buttons to highlight SUB INPUT SOURCE, and press the ► button to display the SUB INPUT SOURCE dialog.
4. Use the ▲/▼ buttons to highlight FIXED (COMPUTER IN 1), and press the ► button to save the change. ([23](#))



5. Press the **SOURCE** button on the remote control or the **SOURCE** button on the Main projector's control panel, the MAIN INPUT SOURCE dialog is displayed on screen. Use the ▲/▼ buttons to highlight the port which is connected to the signal cable, and press the ► button to save the change.

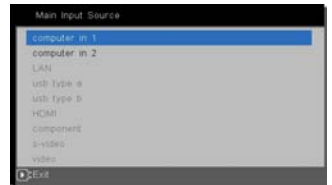

NOTES • When FIXED (COMPUTER IN 1) is selected, the MONITOR OUT DEFAULT setting will not be available. ([User's Manual](#) → [SETUP menu](#))

- When FIXED (COMPUTER IN 1) is selected, only **COMPUTER IN1** and **COMPUTER IN2** inputs can be selected.
- When FIXED (COMPUTER IN 1) is selected, if the **SOURCE** button on the remote control or the projector's **SOURCE** button is pressed, the dialog for selecting the input source will be displayed.

Inputting an image from Main to Sub - Video signal (either component or video)

1. If the STACK menu is already displayed on the screen, proceed to Step 3 below. Otherwise press the **MENU** button on the remote control. If the MENU dialog is displayed, use the **▲/▼** buttons to highlight MAIN, and press the **▶** button. A menu will be displayed. If the MENU dialog is not displayed, the STACK menu will appear.

2. Press the **MENU** button on the remote control or control panel on the Main projector. Use the **▲/▼/◀/▶** buttons to open the COMPUTER IN dialog. ([User's Manual](#) → [INPUT menu](#))

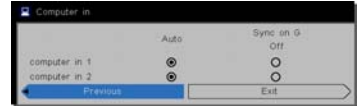

3. To input component signals to **COMPUTER IN1** or **IN2**, set the port to AUTO. Then, use the **▲/▼/◀/▶** buttons to highlight EXIT and press the **▶** button to save the change. To input video signals to **COMPUTER IN1** or **IN2**, set the port to VIDEO. If it is necessary to select a video format, use the **▲/▼/◀/▶** buttons to highlight RETURN and press the **◀** button to display the INPUT menu. Otherwise, use the **▲/▼/◀/▶** buttons to highlight EXIT and press the **▶** button to save the change.

4. Select VIDEO STANDARD in the INPUT menu to display the VIDEO STANDARD dialog. Select AUTO or an appropriate format for the video signal input. Then, use the **▲/▼/◀/▶** buttons to highlight EXIT and press the **▶** button to save the change.

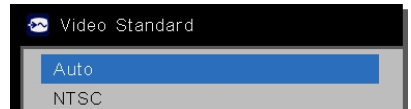

Inputting an image to Sub and Main separately

1. If the STACK menu is already displayed on the screen, proceed to Step 3 below. Otherwise press the **MENU** button on the remote control. If the MENU dialog is displayed, use the **▲/▼** buttons to highlight MAIN, and press the **▶** button. A menu will be displayed. If the MENU dialog is not displayed, the STACK menu will appear.

2. Use the **▲/▼/◀/▶** buttons to go into the following menu.

ADVANCED MENU > OPTION
> SERVICE > COMMUNICATION > STACK

The STACK menu will appear on screen.

([User's Manual](#) → [OPTION menu](#))



(continued on next page)

5.4 Setting the menu - Inputting image to Sub and Main separately (continued)

3. Use the ▲/▼ buttons to highlight SUB INPUT SOURCE, and press the ► button to display the SUB INPUT SOURCE dialog.
4. Use the ▲/▼ buttons to highlight FOLLOW MAIN UNIT, and press the ► button to save the change. (📖23)
5. Press the **SOURCE** button on the remote control or the **SOURCE** button on the Main projector's control panel, the MAIN INPUT SOURCE dialog is displayed on screen. Use the ▲/▼ buttons to highlight the port which is connected to the signal cable, and press the ► button to save the change.

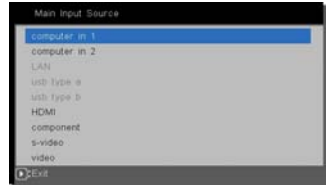

- NOTES
- If FOLLOW MAIN UNIT is selected, selecting an input source for either the Main or Sub projector will cause the other projector to the same source automatically.
 - If FOLLOW MAIN UNIT is selected, **LAN**, **USB TYPE A** and **USB TYPE B** cannot be selected.
 - When FOLLOW MAIN UNIT is selected, if the **SOURCE** button on the remote control or the projector's **SOURCE** button is pressed, the dialog for selecting the input source will be displayed.

6. Scheduling limitations

This model supports Web Control scheduling functions. ([Network Guide](#) → [3. Web Control](#) → [3.7 Schedule Settings](#)) There are some scheduling limitations when Smart Stack is used with an RS232 connection. But for Simple Stack without an RS232 connection, there are no limitations.

Regardless of whether Smart Stack or Simple Stack is used, review the Schedule settings before using the Stack function. Unexpected setting changes may occur when using the Stack function.

Refer to the following for Smart Stack limitations. If you are using Simple Stack, skip this chapter.

Main projector limitations

Functions			LAMP MODE			
			DUAL	ALTERNATE		DUAL/ ALTERNATE
	Power status	Main	ON	ON	OFF	OFF
		Sub	ON	OFF	ON	OFF
Power On			✓	✓	✓	✓
Power Off			✓	✓	✓	✓
Input port change			✓ *1)	✓ *1)	✓ *1)	✓ *1)
My Image			✓	✓	X *2)	X *2)
Messenger			✓	✓	X *2)	X *2)
Slide Show			X *3)	X *3)	X *3)	X *3)

Sub projector limitations

Functions			LAMP MODE			
			DUAL	ALTERNATE		DUAL/ ALTERNATE
	Power status	Main	ON	ON	OFF	OFF
		Sub	ON	OFF	ON	OFF
Power On			X *3	X *3	X *3	X *3
Power Off			✓	✓	✓	✓
Input port change			✓ *1)	✓ *1)	✓ *1)	✓ *1)
My Image			✓	X *2)	✓	X *2)
Messenger			✓	X *2)	✓	X *2)
Slide Show			X *3)	X *3)	X *3)	X *3)

✓ : This item can be scheduled using Web Control and be performed even if the projectors are in a Smart Stack.

✓ *1): This item can be scheduled using Web Control even if the projectors

(continued on next page)

6. Schedule function limitations (continued)

are operating in Smart Stack. If the input port to be changed according to the Schedule function can be used in Smart Stack, the Schedule will be performed. If not, it will not be performed.

X *2): This item can be scheduled using Web Control when the projectors are operating in Smart Stack but will not be performed.







X *3): This item cannot be scheduled using Web Control and will not be performed when the projectors are operating in Smart Stack.

NOTES

- If the Schedule is not performed, an error message will be sent in accordance with the conditions set up in Schedule Execution Error on Web Control. ([📖 Network Guide](#) → [3. Web Control](#) → [3.6 Alert Settings](#))
- If the Schedule function is set to turn off the power when the projectors are operating in Smart Stack, both the Main and Sub projectors will be turned off.
- If the Schedule function on the Main projector is set to turn on the power, the projectors will turn on according to the LAMP MODE setting.
- When both projectors are operating in the DUAL mode and a menu is being displayed on one of the projectors, the Schedule function for My Image and Messenger on the other projector will not be performed.
- Power Off in the table refers to turning off the power and entering into standby mode according to the Smart Stack settings or by pressing the **STANDBY/ON** button on the remote control or Main projector's control panel.
- The projectors cannot be turned on by the Schedule function on the Sub projector. Set it on the Main projector as needed.
- When the Sub projector is turned off according to the ALTERNATE MODE setting, the Schedule function on the Sub projector to turn off its power will be performed without error.







7. Troubleshooting

The following situations can be misinterpreted as a projector defect. Review the following table before arranging for a repair.

Situation	Description	Page Reference
Smart Stack does not function.	<p>The Main and/or Sub projectors do not have power.</p> <p>To use the Smart Stack feature, supply AC power to both the Main and Sub projectors. If AC power is supplied to only one of the projectors, Smart Stack is disabled.</p>	<p> 8 in <i>Quick Start Guide</i></p>
	<p>The RS232 cable between the Main and Sub projectors is not properly connected.</p> <p>To use the Smart Stack feature, connect an RS232 cross cable between the Main and Sub projectors. If the cable is not connected, the Main projector cannot control the Sub projector.</p>	<p> 11</p>
	<p>The Smart Stack menu settings are not working correctly.</p> <p>Check the STACK menu settings on the Main and Sub projectors. To use the Smart Stack feature, one projector must be set to Main and the other projector must be set to Sub.</p>	<p> 18</p>
	<p>Signal cables are not connected correctly.</p> <p>Check the cable connections. Also verify that the cable connections match the port settings in the menu.</p>	<p> 28  10 - 14 in <i>User's Manual</i></p>
The Main and Sub projectors are not operating in synchronization.	<p>The RS232 cable between the Main and Sub projectors is not properly connected.</p> <p>Connect the RS232 cable properly and restart the Main projector.</p>	<p> 11</p>

(continued on next page)

7. Troubleshooting (continued)

Situation	Description	Page Reference
<p>The STACK menu cannot function.</p>	<p>The projector settings are not set up for a Smart Stack. Check these Main and Sub projector settings: - POWER SAVING MODE in SETUP menu: ENABLE - COMMUNICATION TYPE under COMMUNICATION in SERVICE menu: OFF - STACK LOCK in SECURITY menu: OFF</p>	<p> 7</p>
<p>The projector does not respond to the remote control.</p>	<p>The remote control is pointed at the Sub projector. When operating in Smart Stack, only the Main projector can receive remote control signals. Therefore, point the remote control at the Main projector.</p>	<p> 6</p>
<p>The images are either out of focus or not superimposed correctly.</p>	<p>The two images are not superimposed correctly. Adjust the ZOOM ring, VERTICAL and HORIZONTAL adjusters, and the FOCUS ring to superimpose the images. If necessary, adjust CORNER CORRECTION and KEYSTONE as well.</p>	<p> 8</p> <p> 15</p>
<p>The projector images will not superimpose properly despite making fine adjustments.</p>	<p>There are some adjustment differences in the two images. Try resolving the problem with the following steps: - Press the remote button's AUTO IMAGE button on or use AUTO IMAGE on both projectors. - Adjust HORIZONTAL POSITION and VERTICAL POSITION on both projectors. - Check the RESOLUTION setting in the INPUT menu of both projectors, and make certain that both the Main and Sub projector's settings match.</p>	<p> 24 in <i>User's Manual</i></p> <p> 38 in <i>User's Manual</i></p> <p> 42 in <i>User's Manual</i></p>