

USER'S MANUAL
Rev. 01/2007

CD3000 *S*-1 PH THYRISTOR UNIT HEATER BREAK VERSION from 15A to 110A



CD Automation S.r.l.

Via Picasso 34/36 - 20025 - Legnano (MI) - ITALY

Tel +39 0331 577479 - Fax +39 0331 579479

E-Mail: info@cdautomation.com - WEB: www.cdautomation.com



Important warning for safety



Thyristor units are used in power industrial equipment.
The voltages used in the Thyristor unit can cause severe electrical shock, and could be lethal.
Don't remove the plastic cover.

Don't use this unit in aerospace and nuclear application.

Electric Shock Hazard (Risque the choque électrique)

When thyristor unit has been connected to main supply voltage and is switched off, before to touch it be secure that the unit is isolated and wait at least one minute to allow discharging internal capacitors. Thus be secure that:

- Access to thyristor unit is only permitted to specialised personnel;
- The authorised personnel must read this manual before to have access to the unit;
- The access to the unit must be denied to unauthorised personnel.

Important warnings(attention)

Local regulations regarding electrical installation should be rigidly observed.

- Safety regulations must be rigidly observed.
- Don't bend components to maintain insulation distances.
- Protect the unit from high temperature humidity and vibrations.
- Don't touch components to prevent electrostatic discharges on them.
- Verify that all rating is in line with real needs.
- If authorized personnel must measure voltage current etc. on units, take away rings and other jewels from fingers and hands.
- Authorized personnel working on thyristor unit under power supply voltage must work on insulated board. Be secure that board is not connected to earth.

This listing does not represent a complete enumeration of all necessary safety cautions.

Protection(protection)

CD3000 thyristor unit has a polymeric plastic cover to compliance to International specification IP20.

To understand if IP20 protection is sufficient should be evaluated the installation place.

Open Type Equipment.

Earth(terre)

CD3000 family has isolated heatsink. For safety connect the heatsink to earth to avoid shocks in case that circuit board or thyristor lose insulation. Earth impedance should be correspondent to local earth regulation. Periodically the earth efficiency should be inspected.

Electronic supply (alimentation électronique)

CD3000 family electronic circuit should be supplied by dedicated voltage supply for all electronic circuit but not in parallel with contactor's coil, solenoids and other inductive or capacitive loads.

It's recommended to use a shielded transformer.

Electromagnetic compatibility (compatibilité électromagnétique)

Our thyristor units have an excellent immunity to electromagnetic interferences if all suggestions contained in this manual are respected. In respect to a good Engineering practice, all inductive loads like solenoids contactor coils should have a filter in parallel.

Emissions (emission)

All thyristor switching at high speed generate some radiofrequency disturbance. CD3000 series compliance with EMC rules for CE mark. In many installations near electronic devices have not been noted problems. If radiofrequency devices at low frequency are used near the thyristor unit some precautions should be taken like line Filters and shielded cables for input signal and for load cables.



Quick Start



Attention: this procedure must be carried out by skilled people only.

If your CD3000M code is in line with what you really need, then the main configuration is already done by CD Automation and you just need to do the following steps:

1. Verify CD3000S Sizing. Be sure that:
 - The load current is equal or less than the Max current of CD3000S.
 - The load voltage is equal or less than the Max voltage of CD3000S.
2. Verify the Order Code
3. Verify the Installation
4. Verify the Diagram of control connection:
 - All auxiliary connections must be done in line with wirings on this manual.
 - Verify that there isn't a short circuit on the load.
5. Supply the auxiliary voltage of the unit (see Order Code)
6. For size 110A, supply the Fan:
 - 230VAC ±15% 50/60Hz (standard)
 - 110VAC ±15% 50/60Hz (Optional)
7. Supply the Power unit
8. Make Calibration procedure.

The CD3000S is ready to start.

CD3000S Sizing

Wiring with resistive load

$$I = \frac{P}{V}$$

V = Nominal load voltage

I = Nominal load current

P = Nominal load power

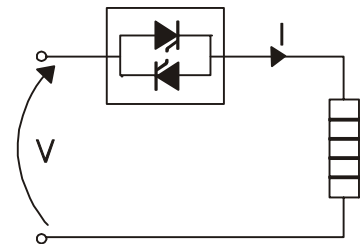

Order Code

CD3000S-1PH							
	Max Current	Operating Voltage	MAX Volt	Aux AC/DC	Input	Firing	Options
	15A	Write	240Vac	12÷24V	SSR	ZC	110v Fan
	25A	Operating	480Vac		0÷10V	BF4 ²	EP External Protection IP20 for size 60÷110A
	35A	Voltage	600Vac ¹		4÷20mA	BF8 ²	EF External fuses and fuse holders
	45A	<=				BF16 ²	NF No fuses
	60A	MAX Volt					ICT ³ internal CT
	90A						HB Heater Break Alarm
	110A						
	¹ Only for size from 35A to 110A						³ Only for size 35A and 45A (Standard for 15A and 25A)
	² Only with Analog Input 0÷10V or 4÷20mA						

Installation

Before to install the CD3000 unit examine for damages or deficiencies. If any is found, notify the carrier immediately. Check that the product features shown on CD3000 cover corresponds to that ordered.

CD3000 unit should be always mounted in vertical position to improve air cooling on heatsink.

Maintain minimum distances in vertical and in horizontal as represented.

Don't install in proximity of hot elements and near units generating electromagnetic interferences.

When more units are mounted in the same cabinet provide air circulation as represented.

Sometimes it is necessary to provide a fan to have better air circulation.

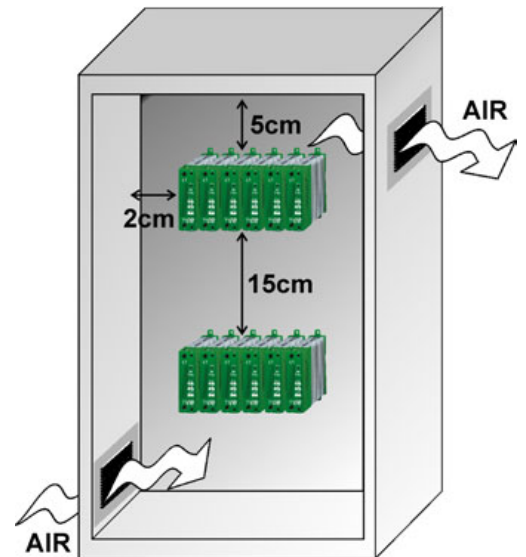

Dimensions and Fixing holes

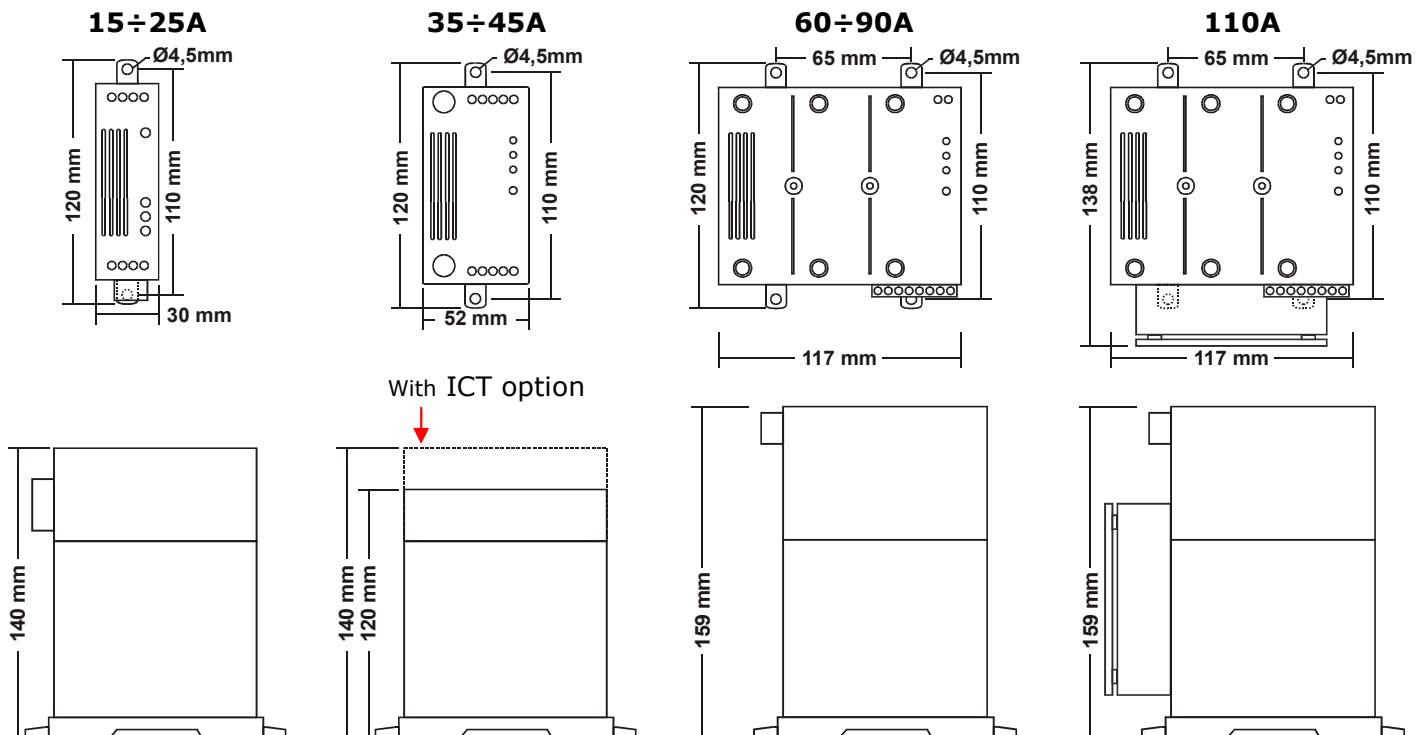

Environmental installation conditions

Ambient temperature	0-40°C at nominal current. Over 40°C use the Derating Curve.
Stocking temperature	-25°C to 70°C
Installation place	Don't install at direct sun light, where there are conductive dust, corrosive gas, vibration or water and also in salty environmental.
Altitude	Up to 1000 meter over sea level. For higher altitude reduce the nominal current of 2% for each 100m over 1000m
Humidity	From 5 to 95% without condense and ice

Diagram of control connection

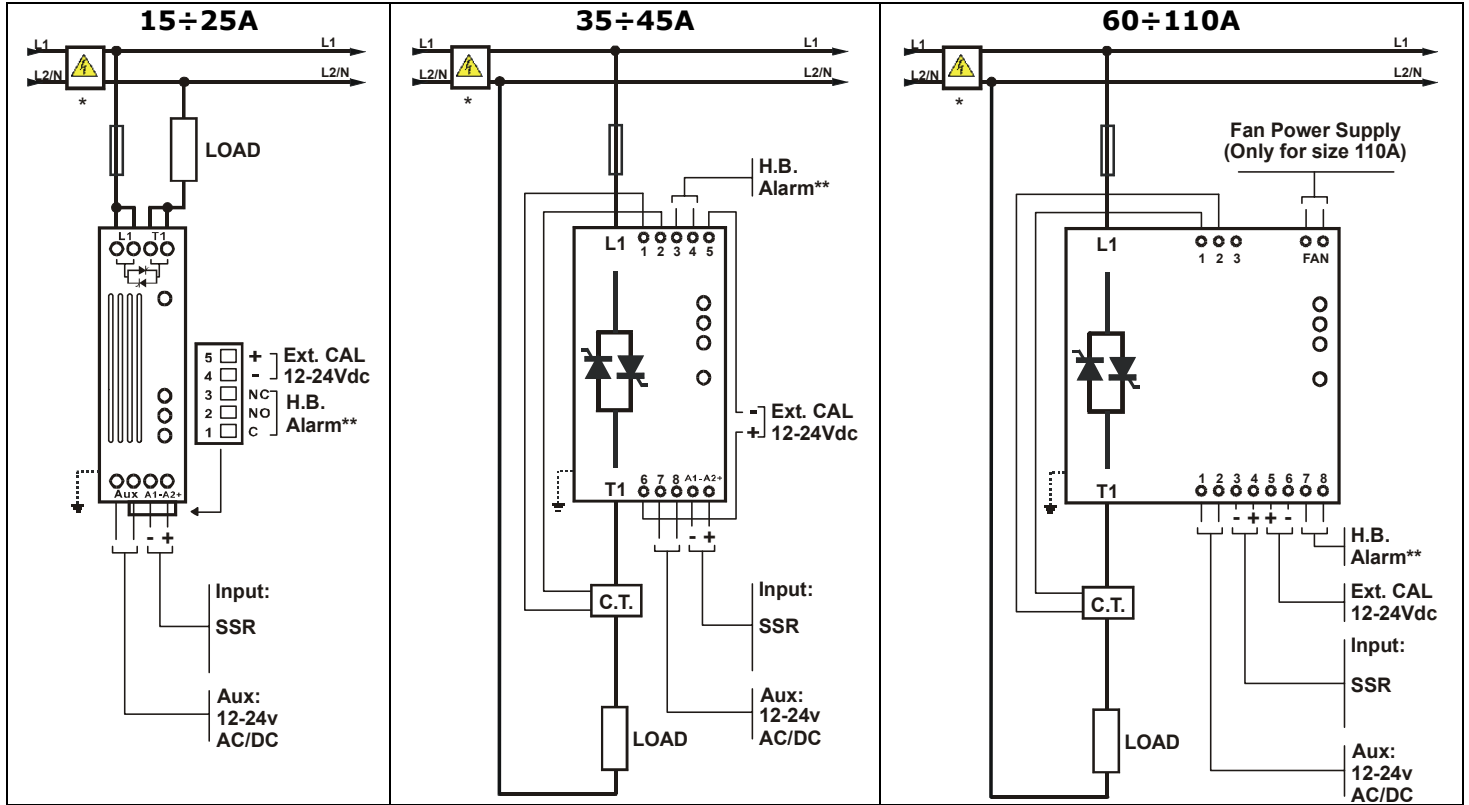

Note:

- The user installation must be protecting by electromagnetic circuit breaker or by fuse isolator (*).
- See par. "HB alarm contact" (**).
- With ICT option, the Current Transformer (C.T.) must not be mounted.

Wiring instructions

CD3000S unit has isolated heatsink. For safety connect the heatsink to hearth using its terminal with hearth symbol.

The CD3000S can be susceptible to airborne interferences from near equipment or from interferences on main supply, so a number of precautions must be taken.

- Contactors coils and chokes must have in parallel a RC filter and must be supplied with a different voltage line.
- All input/output signals must use screened bifilar wires.
- Signal input and output must not route in same cable try and must not be parallel.
- Local regulations regarding electrical installation should be rigidly observed.

Use copper cables and wires rated for use at 75 °C only

Power cable torque (suggested)

Current	Connector Type	Torque Lb-in (N-m)	Wire Range AWG/kcmil	Wire Terminal UL Listed (ZMVV)
15A,25A,35A,45A	M5 Screw	26.6 (3.0)	8	Wire Pin
60A,90A, 110A	M6 Screw	70.8 (8.0)	1	Fork/Spade Terminal Copper Tube Crimp. Lug

Cable dimensions (suggested)

Current	Supply			Load			Earth			Auxiliary Supply	
	Cable		Screw M	Cable		Screw M	Cable		Screw M	Cable	
	mm ²	AWG		mm ²	AWG		mm ²	AWG		mm ²	AWG
15A	4	12	M5	4	12	M5	4	12	M5	0,50	18
25A	6	10	M5	6	10	M5	4	12	M5	0,50	18
35A	10	8	M5	10	8	M5	6	10	M5	0,50	18
45A	10	8	M5	10	8	M5	6	10	M5	0,50	18
60A	16	6	M6	16	6	M6	6	10	M5	0,50	18
90A	35	3	M6	35	3	M6	6	10	M5	0,50	18
110A	35	3	M6	35	3	M6	6	10	M5	0,50	18

Technical Specifications

General features

Cover and Socket material:	PolymericV2
Heat-sink:	Anodized aluminum
Delay switch ON time:	0.5 period Max
Delay switch OFF time:	0.5 period Max
Auxiliary Voltage:	12÷24V dc/ac (max 70mA)
Fan voltage: (Only for size 110A)	230Vac ±15% 14W (110Vac opt.)

Input features

Logic input SSR:	4 ÷ 30Vdc 5mA Max (ON ≥ 4Vdc OFF < 1Vdc)
Analog Input: (Standard)	0 ÷ 10Vdc (15KΩ)
Analog Input:	4 ÷ 20mA (100Ω)

Heater Break Alarm

Is a microprocessor based circuit to diagnose partial or total load failure and short circuit on SCR and fuses failure.

Discrimination better than 20%.Latching alarm.

Relay Output: 0.5A at 125VAC

Power output features

Size	Voltage range	Repetitive peak reverse Voltage		Latching current.	Max peak one cycle	Leakage current	I ² T value thyristor	Frequency range	Power loss	Isolation Voltage
		480V	600V							
(A)	(V)	480V	600V	(mAeff)	(10ms) (A)	(mAeff)	tp=10msec	(Hz)	I=Inom (W)	Vac
15A	24÷480	1200	1200	150	230	15	610	47÷70	18	2500
25A	24÷480	1200	1200	150	230	15	610	47÷70	30	2500
35A	24÷600	1200	1600	250	400	15	780	47÷70	42	2500
45A	24÷600	1200	1600	250	600	15	1800	47÷70	54	2500
60A	24÷600	1200	1600	450	1000	15	4750	47÷70	72	2500
90A	24÷600	1200	1600	450	2000	15	19100	47÷70	108	2500
110A	24÷600	1200	1600	450	1540	15	11300	47÷70	137	2500

Derating Curve

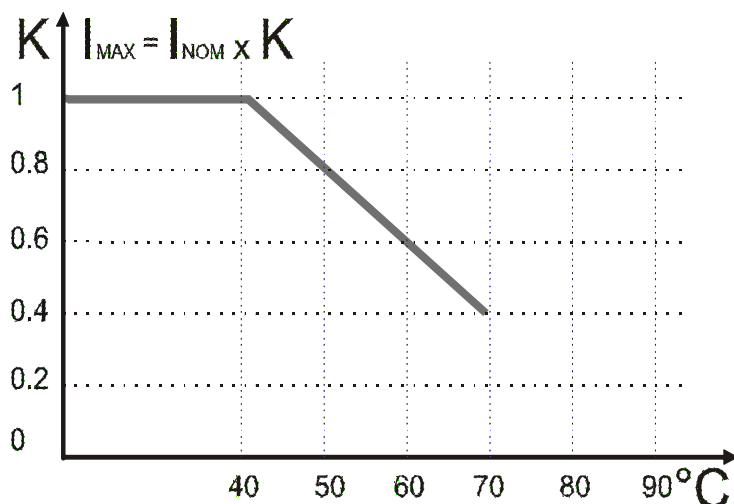

Led status and Alarms

The following events and alerts don't stop the unit:

- SCR Short Circuit
- Heater Break

When one of these alarms is active, the HB relay change status.

LED	STATUS	DESCRIPTION
ON	○	Load IS NOT Powered
	●	Load IS Powered
SC	○	SCR OK
	●	SCR short circuit
HB	○	Load OK
	●	Load Fault
	○	= OFF
	●	= ON

Heater break alarm and SCR short circuit



The Heater Break circuit to work properly must have at least an input of 25% of the nominal current.

H.B. circuit read load current via a current transformer 25-50/0.05 or 100/0.05 depending on thyristor size.

Minimum current is 30% of the current transformer size's. If load current is below this value make two turns or more around current transformer. H.B. circuit also diagnoses fuse failure.

HB alarm contact

CD3000S up to 25A is supplied with Heater Break (HB) alarm contacts normally opened (NO) and normally closed (NC), for the other sizes instead, the contact standard of alarm is normally opened (NO):

- In normal conditions (without alarm) and with auxiliary power supply, the contact to the terminals has opened (relay coil energized).
- In alarm condition or without auxiliary power supply the contact to the terminals is closed (relay coil not energized).

if you wish to change the alarm contact put the jumper as shown:

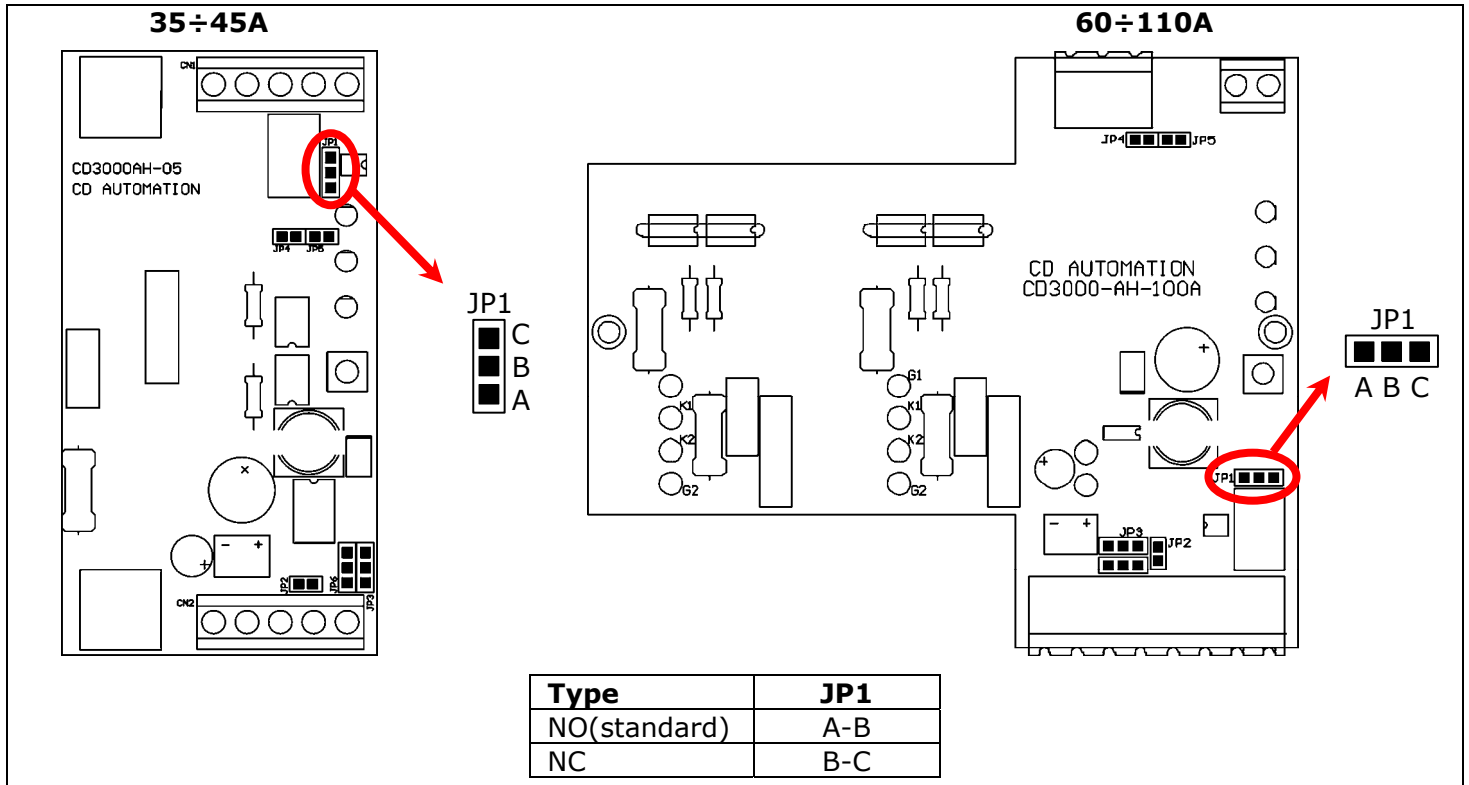

Heater break Calibration procedure

An automatic function sets the Heater Break Alarm.

The auto setting function can be activated using the "CAL" button on front unit, or supply with 12-24Vdc the digital input "Cal Ext." (See Diagram of control connection).

The Heater Break calibration procedure is performed in this way:

- CD3000S gives the maximum voltage output
- all LEDs are on, this means that calibration procedure is active
- The values of voltage and current are stored in memory
- After a minute the CD3000S comes back to the initial situation

If load current decreases for partial or total load failure (sensitivity 20%) the yellow LED become ON and alarm relay change status.

If CD3000 is still in conduction with no input signal (LED green OFF) it means that there is a short circuit on thyristors and red LED (SC) become ON.

If the load has been changed the Heater Break calibration procedure must be done again.

Firing setting

ZC firing mode is used with Logic Output from temperature controllers and the Thyristor operates like a contactor. The Cycle time is performed by temperature controller. ZC minimizes interferences because the Thyristor unit switches ON-OFF at zero voltage.

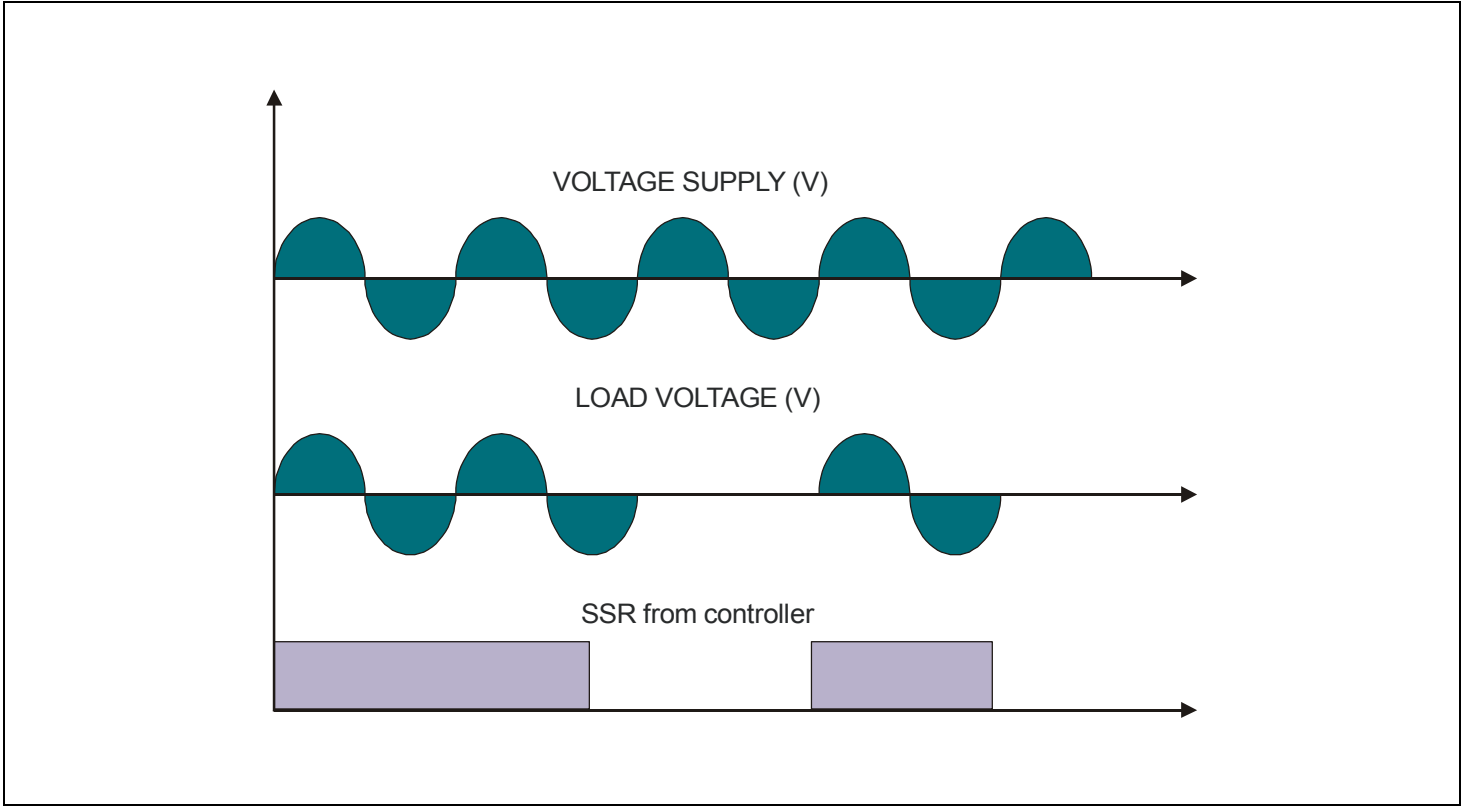

Input setting

The input type is already configured in line with customer requirements that are defined in the complete product code. However, verify that the jumper are set as below represented".

15÷25A

JP3 JP6
 C A
 B B JP2
 A C

35÷45A

CD3000AH-05
CD AUTOMATION

JP6 JP3
 C C
 B B JP2
 A A

60÷110A

CD AUTOMATION
CD3000-AH-100A

JP3 C B A JP2
 JP6 C B A

Input	JP2	JP3	JP6
SSR	Open	B-C	A-B

Fuses and Fuse holder



Warning: High speed fuses are only used for the thyristor protection and can not be used to protect the installation.

CD3000S unit must be protected against short circuit by High speed fuses.

The Fuses must have I²t 20% less than thyristor's I²t.

The warranty of thyristor is null if no proper fuses are used. See tab.

Fuses and Fuse Code for CE.

Size	Fuse and Fuse holder CODE	Fuse CODE	Current (ARMS)	I ² T (A ² sec.)
15A	FFH1038/16A	FU1038/16A	16	150
25A	FFH1038/32A	FU1038/32A	32	600
35A	FFH1451/40A	FU1451/40A	40	1650
45A	FFH1451/50A	FU1451/50A	50	2000
60A	FFH2258/80A	FU2258/80A	80	6550
90A	FFH2258/125A	FU2258/125A	125	14000
110A	FFH2760/160A	FU2760/160A	160	15000

Fuse Holder size

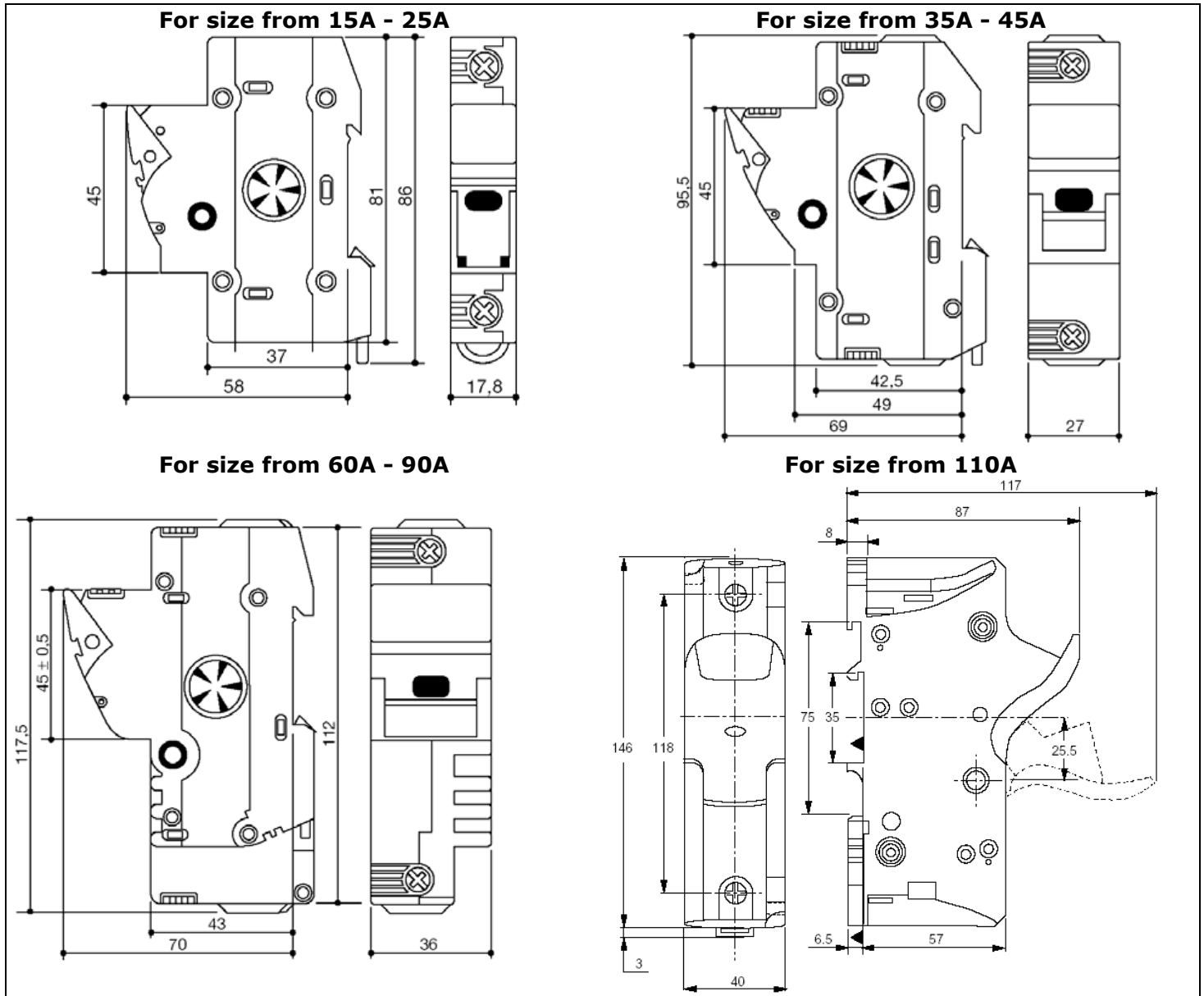

Maintenance

In order to have correct cooling, the user must clean the heatsink and the protective grill of the fans. The frequency of this servicing depends on environmental pollution.

Also check periodically if the screw for the power cables and safety earth are tightened correctly (See Diagram of control connection)

Trouble Shooting

Small problems sometimes can be solved locally with the help of the below tab of trouble shooting. If you don't succeed, contact us or your nearest distributor.

Symptom	Indication on front unit	Possible reasons of the symptom	Actions
Thyristor unit doesn't go in conduction with input signal	Green LED (ON) light off	<ul style="list-style-type: none"> No voltage auxiliary power No input signal Reversed polarities of input signal 	<ul style="list-style-type: none"> Give auxiliary voltage supply (See Diagram of connection) Provide to give input signal Reverse the input signal polarity
	Green LED (ON) light off	<ul style="list-style-type: none"> Fuse failure Load failure Load connection interruption Thyristor faulty <p>The yellow led (HB) is light on</p>	<ul style="list-style-type: none"> Substitute the fuse Check the load Check the wiring Substitute the faulty thyristor
Load current flows also with no input signal	Green LED (ON) is always light on	<ul style="list-style-type: none"> Wrong wiring Short circuit on thyristor <p>The red led (SC) is light on</p>	<ul style="list-style-type: none"> Check the load wiring Substitute the thyristor
Current flows at nominal value but Yellow LED (HB) is light on	Yellow LED (HB) light on	<ul style="list-style-type: none"> HB circuit not tuned Current transformers not properly wired 	<ul style="list-style-type: none"> Make HB calibration procedure Control current transformers wiring
Current flows at nominal value but Red LED (SC) is light on	Red LED (SC) light on	<ul style="list-style-type: none"> HB circuit not tuned 	<ul style="list-style-type: none"> Make HB calibration procedure
Thyristor unit doesn't work properly		<ul style="list-style-type: none"> Auxiliary voltage supply out of limits Wrong input signal selection. Wrong input signal calibration (out of range) 	<ul style="list-style-type: none"> Verify the auxiliary voltage supply Control input signal setting. Repeat input calibration procedure.

Warranty condition

CD Automation gives a 12 months warranty to its products. The warranty is limited to repairing and parts substitution in our factory and does exclude products not properly used and fuses.

Warranty does not include products with serial numbers deleted.

The faulty product should be shipped to CD Automation at customer's cost and our Service will evaluate if product is under warranty terms.

Substituted parts remain of CD Automation property

