

PRINTRONIX®

General Purpose Input/Output (GPIO) Module
Programmer's Reference Manual

Thermal Series Printers

Product Warranty

Printronix warrants that the Products furnished under this Agreement shall be free from defects in material and workmanship for a period of one year from the date of shipment from the Printronix facility. This warranty is applicable only if the products have had normal utilization within the published specifications as modified from time to time, have been maintained in accordance with recommended procedures with Printronix approved parts, and have not been modified or altered in a manner not approved by Printronix.

For printers sold within the area in which Purchaser normally provides field service:

For all printers the Purchaser will provide the end-user with a 90-day on-site warranty. Any printer or part therein found defective within one year of original shipping date from a Printronix facility shall be returned to Printronix and be repaired or replaced at the option and expense of Printronix. Purchaser shall pay shipping cost to the Printronix facility and Printronix will return the item(s) at its expense.

For printers sold outside the area, within the Continental United States, in which Purchaser normally provides field service:

Any printer found defective within 90 days from the date of shipment to the end user will be repaired at the end user's location. If the end user is located within 100 miles of an Authorized Service Provider's location, warranty service will be performed at no charge. If the end user is located more than 100 miles from an Authorized Service Provider's location, travel time and expenses in excess of 100 miles will be billed to the end user at current rates or the printer may be shipped to the nearest Authorized Service Center for repair. If the end user elects to ship the printer for warranty repair, the end user shall pay the shipping cost to the Authorized Service Center and the printer will be returned at Printronix' expense.

The Products may be equipped with a general purpose input/output circuit board and corresponding pin connection (GPIO) which allow the Purchaser's or end user's printer to function as a controller in a computer system.

Printronix publishes the specifications associated with GPIO and the pin connection and warrants that the printer's input and output parameters at the pin connection conform to those specifications. Except as expressly warranted, GPIO is sold on an "as is" basis. There are no other warranties whatsoever, express or implied, concerning GPIO.

Purchaser's remedies are expressly limited to Printronix' obligations as stated above, and in no event shall Printronix be held liable for any incidental or consequential damages or loss of use, or other commercial loss, however occasioned.

THE WARRANTIES SET FORTH IN THIS ARTICLE AND THE OBLIGATIONS AND LIABILITIES THEREUNDER ARE IN LIEU OF, AND THE PURCHASER HEREBY WAIVES, ALL IMPLIED GUARANTEES AND WARRANTIES, INCLUDING WITHOUT LIMITATION, ANY WARRANTY OF MERCHANTABILITY OR FITNESS FOR A PARTICULAR PURPOSE. IN NO EVENT SHALL PRINTRONIX BE HELD LIABLE FOR ANY INCIDENTAL OR CONSEQUENTIAL DAMAGES OR LOSS OF USE, OR OTHER COMMERCIAL LOSS, HOWEVER OCCASIONED.

Notice of Copyright

This document contains proprietary information protected by copyright. No part of this document may be reproduced, copied, translated, or incorporated in any other material in any form or by any means, whether manual, graphic, electronic, mechanical, or otherwise, without the written consent of Printronix, Inc.

All non-Printronix registered and/or unregistered trademarks used throughout this manual are the sole property of their respective owners.

Copyright © 2003, 2013, 2015 Printronix, Inc. All rights reserved.

Table of Contents

- 1 GPIO..... 7**
 - Overview..... 7
 - Upgrading from T5000 to T8000 7
 - Panel keys..... 7
 - Panel messages 7
 - Menu Overview 8
 - GPIO Menu Descriptions..... 9
 - Connector Pinout..... 13
 - Signal Descriptions..... 14
 - Outputs..... 14
 - Inputs 15
 - Power and Grounds 16
 - Hardware Specifications..... 16
 - Pre-Programmed Inputs for Use with Printer Menus..... 16
 - Pre-Programmed Outputs for Use with Printer Menus 16
 - External Power Outputs 16
 - Compatibility 16
 - Electrical..... 16

- A Inputs And Outputs - Electrical 19**
 - GPIO Opto-coupled Input Circuit..... 19
 - GPIO Opto-coupled Output Circuit..... 19

- B Contact Information 21**
 - Printronic Supplies Department 21
 - Corporate Offices 22

1 ***GPIO***

Overview

The Printronix General Purpose Input/Output (GPIO) module is an optional accessory for thermal printers. It enables the printers to interface with an external device such as a label applicator system.

Simple printer menus allow for programming three of the eleven pre-defined interface signals (seven outputs, four inputs) to select particular polarity or logic functions that can meet practically all typical print/apply requirements or be compatible with practically all the features available on other manufacturers' external I/O interfaces. This allows easy migration of Printronix thermal and line matrix printers to new or existing systems. Field interface is accomplished through an industry standard 50-pin D-type connector.

GPIO is available as a factory option or field installable kit that also includes a mating connector for field interface, installation instructions, and operation manual.

Although there are seven pre-defined outputs and four pre-defined inputs, the GPIO module actually contains a total of eight inputs, eight outputs (all inputs and outputs are optically-isolated), and four relays. By using Printronix GPIO Manager software, these can all be custom configured and be mapped in conjunction with Printronix proprietary functions such as ODV analyses, printer front panel keys, and communications ports to provide powerful functions, including multiple interfaces, previously not attainable with a single accessory module.

Upgrading from T5000 to T8000

The T8000 GPIO board is a new design, but the connections on the 50-pin connector are the same. The T8000 is backwards compatible with T5000 regarding number of I/O's and the supported events and actions. However, to use an existing T5000 GPIO application on a T8000, some changes need to be made to the GPIO table:

- First, install the latest version of PrintNet Enterprise Suite (version 4.01L or later).
- Run the PrintNet Enterprise Suite application and open the GPIO Manager.
- Set the printer model to T8 under File > GPIO Configuration > Printer Model.

Panel keys

Due to the differences in the front panel, events that relate to the panel keys will be highlighted in the table after you've changed the model number to T8. This indicates that these entries need to be changed to use a proper key value. As the T8000 has a different set of keys (e.g. the addition of the two soft keys) you need to redesign your solution to use the keys that are appropriate.

Panel messages

When displaying GPIO messages on the T5000, the existing message on the 2x16 character LCD display will be replaced. As the T8000 has a larger display and uses smaller fonts, GPIO messages will now be shown in a dedicated area on the online screen, still allowing displaying all other information like status, printer name etc. When the printer is offline, the GPIO messages will be shown in a pop-up box. To prevent annoying popups, it is recommended to design your GPIO solution in a way that messages are only shown when the printer is online.

Menu Overview

The GPIO menu is located under the System icon as shown in Figure 1 below. This submenu is only present if either the GPIO option is installed and/or a user defined table. The figure shows the available menus along with the defaults.

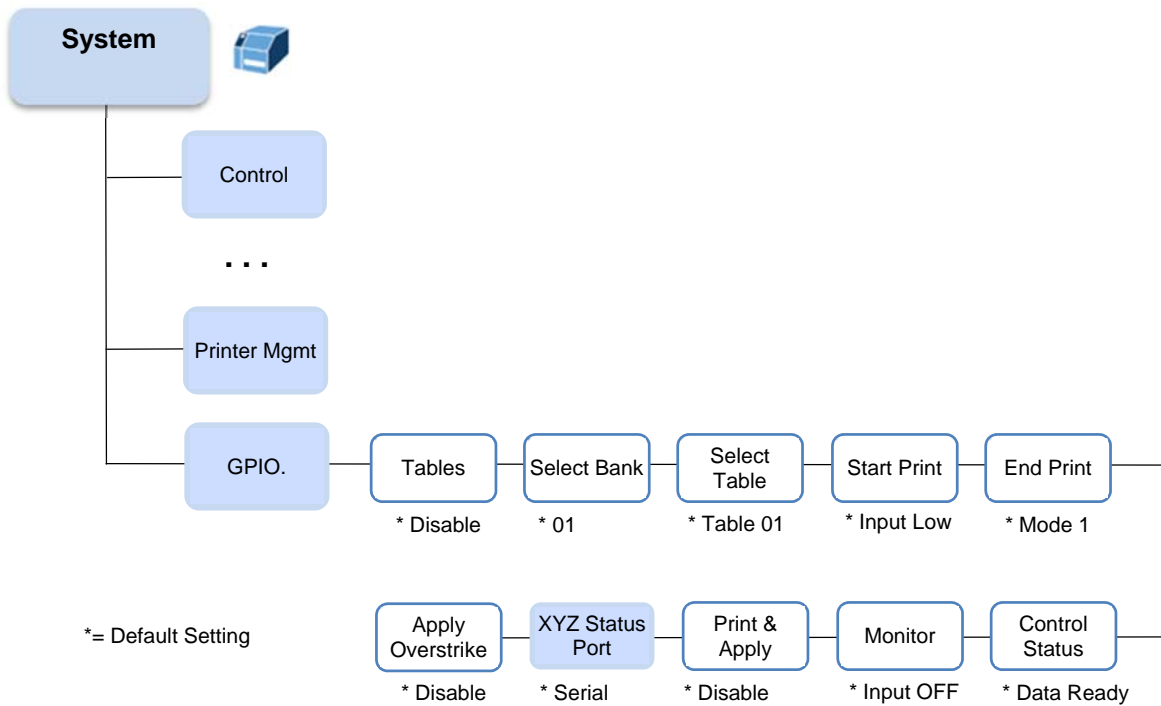

Figure 1 GPIO Menu Overview

IMPORTANT XYZ Status Port menu for reference only. This is a proprietary feature not available with the standard GPIO product.

GPIO Menu Descriptions

System > GPIO > Tables	
Allows you to select a mapping table.	
Disable	The GPIO is not active.
Enable	The user-defined mapping table.
Internal	The standard internal mapping table.
User Defined	The user-defined mapping table. This option appears only if a user-defined table is downloaded to the printer
Factory Default	Disable
IMPORTANT	On Print & Apply machines, set GPIO Tables to Disable to avoid unexpected tamp motion during printer configuration. After all configurations are complete, set <i>Tables</i> to Enable.

System > GPIO > Select Bank	
Allows you to select a bank of tables.	
Minimum	01
Maximum	08 (since the maximum number of tables is 64)
Range	The range is from 01 to X, where X is the total number of defined tables (see <i>Select Table</i> menu) divided by eight, rounded up to the next whole number (e.g., 15 tables = 2 banks).
Factory Default	01
IMPORTANT	This menu appears only if Tables is set to “Enable” or “User Defined”.

System > GPIO > Select Table	
Allows you to select a table. This menu appears only if <i>Tables</i> is set to "Enable" or "User Defined".	
Minimum	Table 01
Maximum	Table 64
Range	The range depends on the number of defined tables (maximum 64) and the GPIO Select Bank setting. See Table 1.
Factory Default	Table 01
IMPORTANT	This menu appears only if <i>Tables</i> is set to "Enable" or "User Defined".

Table 1 GPIO Sel. Table Range

GPIO Select Bank Setting	GPIO Sel. Table Range
01	01 to 08
02	09 to 16
03	17 to 24
04	25 to 32
05	33 to 40
06	41 to 48
07	49 to 56
08	57 to 64

System > GPIO > Start Print	
Start print logic.	
Input Low	Start print when input asserts low.
Input High	Start print when input asserts high.
Factory Default	Input Low
IMPORTANT	This menu appears only if <i>Tables</i> is set to "Internal".

System > GPIO > End Print	
End print logic.	
Mode 1	Normally high. Low only when a label is being moved forward.
Mode 2	Normally low; high only when a label is being moved forward.
Mode 3	Normally high; low for 50 milliseconds when a label has been printed and positioned. Always high during continuous printing modes.
Mode 4	Normally low; high for 50 milliseconds when a label has been printed and positioned. Always low during continuous printing modes.
Mode 5	Normally high. When the label has been printed completely, a low going, 50 millisecond pulse is sent. (This mode shows the end of a label print cycle, even in batch mode where labels are continuously being printed.).
Mode 6	Identical to Mode 5, except normally low with a high going 50 millisecond pulse.
Mode 7	Normally high. At the beginning of a label being printed, the output is set low. When the label is completed, the signal goes high. If another label has started printing, the signal stays high for 50 milliseconds. (This mode shows start and end of a label print cycle, even in batch mode where labels are continuously printed.).
Mode 8	Identical to Mode 7, except normally low with high going signal.
Factory Default	Mode 1
IMPORTANT	This menu appears only if <i>Tables</i> is set to "Internal".
IMPORTANT	End print applies only to printed labels. Output remains in normal state for blank labels.

System > GPIO > Control Status	
Start print logic. This menu appears only for thermal printers, and only if <i>Tables</i> is set to "Internal".	
Data Ready	Low when sufficient data has been received to begin printing the next label. High whenever printing is stopped after the current label due to any condition causing the printer to pause or in the absence of a label format.
Offline	Low whenever the printer is offline. High whenever the printer is able to receive command streams and print labels.
Factory Default	Data Ready
IMPORTANT	This menu appears only if <i>Tables</i> is set to "Internal".

System > GPIO > Monitor	
Shows the status of the GPIO input opto-couplers on the control panel LCD. A '.' (dot) indicates that the corresponding opto-coupler is inactive. A ' ' (bar) indicates the opto-coupler is active.	
Input OFF	Start print when input asserts low.
Input ON	Start print when input asserts high.
Factory Default	Input OFF
IMPORTANT	This menu appears only if <i>Tables</i> is set to "Enable", "Internal", or "User Defined".

System > GPIO > Print&Apply	
Enables the use of print and apply hardware.	
Disable	Print & Apply mode disabled.
Enable	Print & Apply mode enabled.
Factory Default	Disable

System > GPIO > XYZ Status Port	
This menu is for reference only and not available with the standard product.	
Disable	Feature disabled.
E-NET Data Port	Data sent out the Ethernet designated data port.
Serial	Data sent out the serial port.
E-Net Stat Port	Data sent out the Ethernet designated status port.
USB	Data sent out the USB port.
IEEE 1284	Data sent out the IEEE-1284 port.
Factory Default	Serial

System > GPIO > Apply Overstrike	
This menu is used when <i>Print&Apply</i> is set to "Enable".	
Disable	RFID or verifier overstrike labels are not applied to boxes.
Enable	RFID or verifier overstrike labels are applied to boxes like passing labels.
Factory Default	Disable

Connector Pinout

The Printronix GPIO feature uses a 50-pin DIN connector to interface to Label Applicators, Programmable Logic Controllers, and the like.

Using the printer resident pre-programmed I/O mapping tables, a number of connector pins are each assigned a specific function as listed in the table below. See "Signal Descriptions" on page 14 for a complete description these functions.

INPUT OPTO-COUPLER		CONNECTOR PINS	
1	Reprint Last Label	1 (anode)	9 (cathode)
2	Start Print	2 (anode)	10 (cathode)
3	Feed	3 (anode)	11 (cathode)
4	Pause	4 (anode)	12 (cathode)
5 to 8	Not Used	5 to 8 (anode)	13 to 16 (cathode)

OUTPUT OPTO-COUPLER		CONNECTOR PINS	
1	Ribbon Low	18 (collector)	26 (emitter)
2	Ribbon Out	19 (collector)	27 (emitter)
3	Media Out	20 (collector)	28 (emitter)
4	Service Required	21 (collector)	29 (emitter)
5	End Print	22 (collector)	30 (emitter)
6	Control Status	23 (collector)	31 (emitter)
7	Not Used	24 (collector)	32 (emitter)
8	Power On	25 (collector)	33 (emitter)

Signal Descriptions

Outputs

Ribbon Low

- Normally high, goes low when ribbon remaining is about 50 meters.
The menu *Media > Ribbon > Ribbon Low* can be set to “Disable” or “Enable.” If “Disable” is selected, the GPIO signal is disabled.
- Stays low when ribbon is out.

Ribbon Out

Normally high. Low during a Ribbon Out condition.

Media Out (Label Out)

Normally high. Low during a Label Out condition.

Error (Service Required)

Normally high. Goes low whenever the printer is stopped for a fault condition that requires the user to perform an action to start again. This can be head open, or any operation fault condition, etc.

End Print

Logic programmable via printer menu.

- **Mode 1.** The default. Normally high. Low only when a label is being moved forward.
- **Mode 2.** Normally low; high only when a label is being moved forward.
- **Mode 3.** Normally high; low for 50 milliseconds when a label has been printed and positioned. Always high during continuous printing modes.
- **Mode 4.** Normally low; high for 50 milliseconds when a label has been printed and positioned. Always low during continuous printing modes.
- **Mode 5.** Normally high. When the label has been printed completely, a low going, 50 millisecond pulse is sent. (This mode shows the end of a label print cycle, even in batch mode where labels are continuously being printed.)
- **Mode 6.** Identical to Mode 5, except normally low with a high going 50 millisecond pulse.

- **Mode 7.** Normally high. At the beginning of a label being printed, the output is set low. When the label is completed, the signal goes high. If another label has started printing, the high signal stays high for 50 milliseconds. (This mode shows start and end of a label print cycle, even in batch mode where labels are continuously printed.)
- **Mode 8.** Identical to Mode 7, except normally low with high going signal.

NOTE: End Print applies only to printed labels. Output remains in normal state for blank labels.

Data Ready/Off Line

Programmable via printer menu.

- **Ready Mode.** The default. Low when sufficient data has been received to begin printing the next label. High whenever printing is stopped after the current label due to any condition causing the printer to pause or in the absence of a label format.
- **Off Line Mode.** Low whenever the printer is offline. High whenever the printer is able to receive command streams and print labels.

Power On

Low when valid power is applied to printer, i.e., the main CPU is operating. During power off, this should be in a high impedance state so an external device can pull up to a voltage.

Inputs

Reprint

When low going edge is detected, the printer reprints the last label printed prior to receiving the signal. Only one label is reprinted. The signal must toggle high then low again to reprint another label.

StartPrint

Signal polarity selectable via printer menu.

- **Active Low.** The default. When low, the printer will print one label. If still low at the end of the label, another label will be printed without delay. If high, the printer will not print. If the signal goes high while the printer is printing a label, printing will continue until the label has completed. The printer will stop and obey any other settings for end of label control such as eject, feed a particular distance, etc.
- **Active High.** Identical to Mode 1 except opposite polarity. A high input will print one label, etc.

Feed

- If low, will feed a blank label (or labels) until a high input is detected. A high input stops the feeding of blank labels, and last blank label fed will stop at top-of-form.
- This signal has the lowest priority over other functions. If the printer is printing, ODV is voiding, or there are any error conditions, the signal is ignored.

NOTE: This signal also has lower priority than Start Print.

Pause

- When a signal toggles from high to low, it causes the printer to go into pause as if the PAUSE key were pressed.
- If a signal goes low during an operation, it will be treated the same way as if the PAUSE key were pressed, i.e., the label will finish if one was being printed, etc.
- This condition can only be reset by pressing the PAUSE key or by a similar command from a host if you have created one.

- The signal must toggle high then low again to achieve another valid pause input.

Power and Grounds

- +24 VDC
- 24 VDC Return (Ground)
- + 5 VDC
- 5 VDC Return (Ground)
- Frame Ground

Hardware Specifications

This section is a quick reference to the GPIO connections available when using the printer resident pre-programmed I/O mapping tables as well as the electrical specifications of the components used and the voltages available. See page 19 for a schematic diagram.

Pre-Programmed Inputs for Use with Printer Menus

Start Print (Polarity programmable via printer menu); input 2 Pause; input 4 Feed; input 3 Reprint; input 1 Not used; inputs 5, 6, 7, 8

Pre-Programmed Outputs for Use with Printer Menus

End Print (8 modes via printer menu); output 5 Data Ready/Online (programmable via printer menu); output 6 Ribbon Low; output 1 Ribbon Out; output 2 Error - Service Required; output 4 Media Out; output 3 Power On; output 8 Not used; output 7

External Power Outputs

+5VDC (.5 A fused)
+24VDC (.25 A fused) – not available if cutter installed Two DC ground pins

Compatibility

GPIO is compatible with all accessories except wireless communication options.

Electrical

Inputs (eight total)

- Opto-isolated, separate anode and cathode pins per input
- Input voltage range (steady state); 5-10 VDC
- Series resistor; 4700 ohm, .25W
- Resistor through hole mounted; changeable with common techniques

Outputs (eight total)

- Opto-isolated, NPN transistor, separate collector and emitter pins per output

- Open collector output, NPN transistor
- Current – 300 ma maximum
- 70 VDC collector to emitter voltage maximum.

Relays (four total)

- Each relay has three pins connected to the 50 pin connector: COM, NC and NO.
- Contacts are electrically isolated from the printer electronics.

WARNING For safety reasons voltage should be limited to 42 volts DC max.

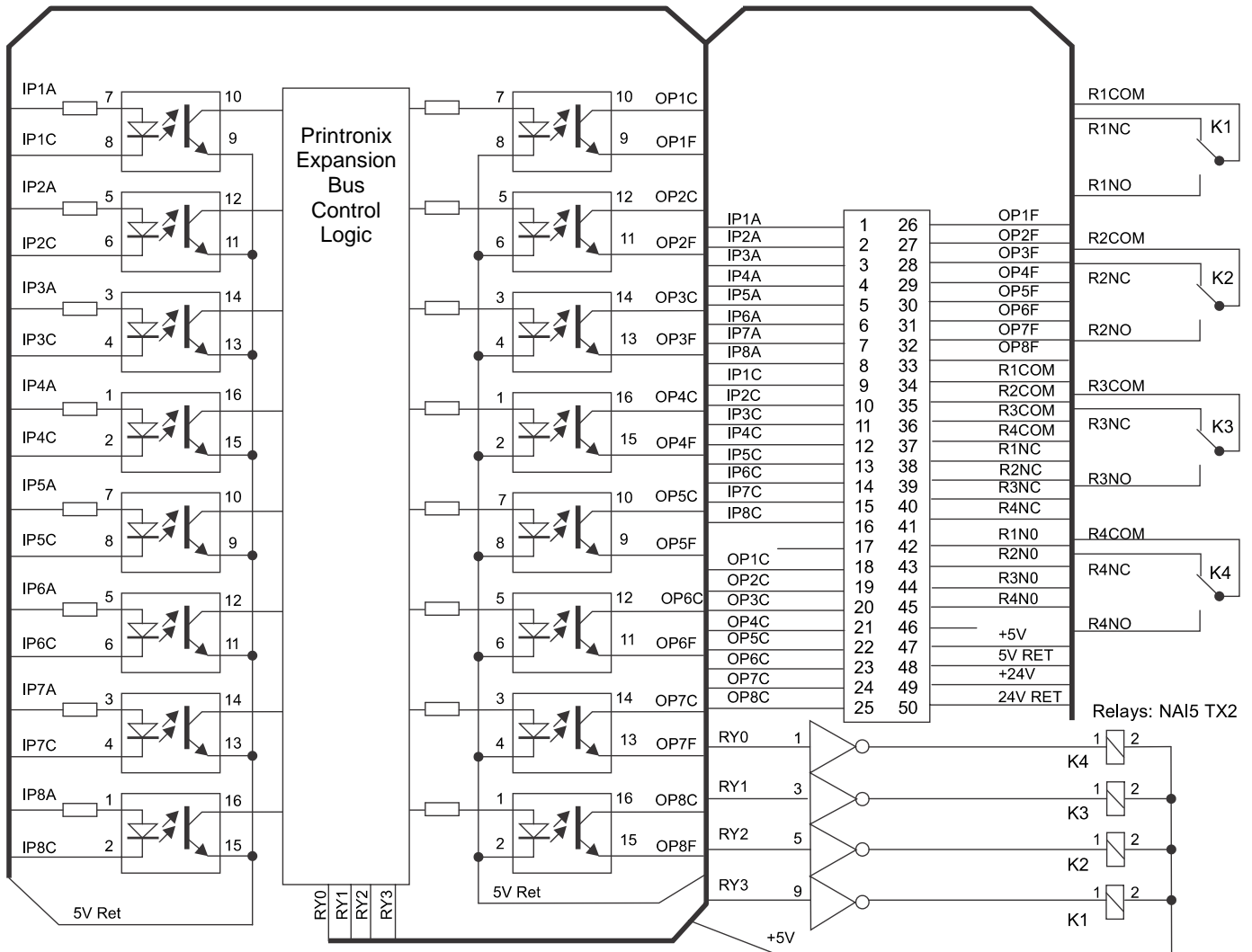

All anode protection resistors are 4.7K Ohms.

Figure 2 Basic GPIO Schematic Diagram

A *Inputs And Outputs - Electrical*

GPIO Opto-coupled Input Circuit

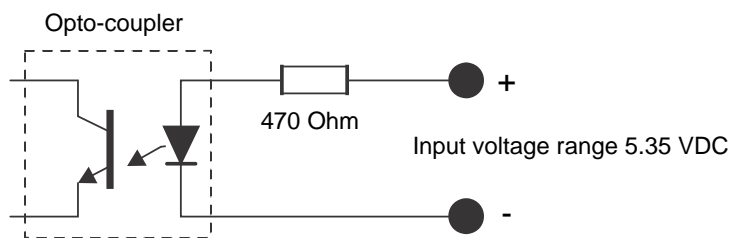

GPIO Opto-coupled Output Circuit

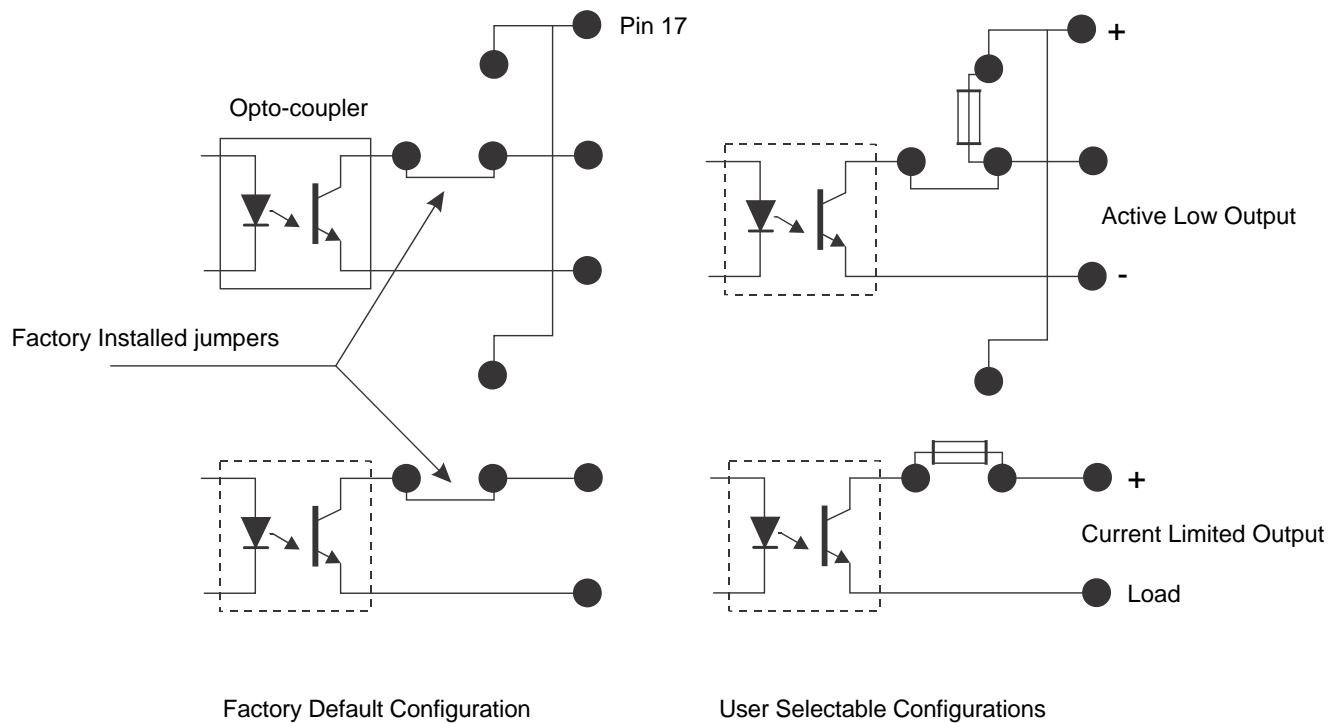

B *Contact Information*

Printronix Customer Support Center

IMPORTANT Please have the following information available prior to calling the Printronix Customer Support Center:

- Model number
- Serial number (located on the back of the printer)
- Installed options (i.e., interface and host type if applicable to the problem)
- Configuration printout: (See "Printing A Configuration") in your printers Administrator's manual.
- Is the problem with a new install or an existing printer?
- Description of the problem (be specific)
- Good and bad samples that clearly show the problem (faxing or emailing of these samples may be required)

Americas	(714) 368-2686
Europe, Middle East, and Africa	(31) 24 6489 311
Asia Pacific	(65) 6548 4114
China	(86) 800-999-6836

<http://www.printronix.com/support.aspx>

Printronix Supplies Department

Contact the Printronix Supplies Department for genuine Printronix supplies.

Americas	(800) 733-1900
Europe, Middle East, and Africa	(33) 1 46 25 19 07
Asia Pacific	(65) 6548 4116 or (65) 6548 4132
China	(86) 400-886-5598
India	(800) 102-7869

<http://www.printronix.com/supplies-parts.aspx>

Corporate Offices

Printronix, Inc.
15345 Barranca Parkway
Irvine, CA 92618
U.S.A.
Phone: (714) 368-2300
Fax: (714) 368-2600

Printronix Inc.
c/o Printronix Nederland BV
Bijsterhuizen 11-38
6546 AS Nijmegen
The Netherlands
Phone: (31) 24 6489489
Fax: (31) 24 6489499

Printronix Schweiz GmbH 42
Changi South Street 1
Changi South Industrial Estate
Singapore 486763
Phone: (65) 6542 0110
Fax: (65) 6546 1588

Printronix Commercial (Shanghai) Co. Ltd 22F,
Eton Building East
No.555, Pudong Av.
Shanghai City, 200120, P R China
Phone: (86) 400 886 5598
Fax: (86-21) 5138 0564

Visit the Printronix web site at www.printronix.com