

HEAT CONTROLLER, INC.

INSTALLATION MANUAL

VMH 09/12/18/27/36

Version C

InverterFlex

Ductless Mini-Split Heat Pump

Table of Contents

Safety Precautions
 Warnings and Cautions 2

Installation Instructions
 Selecting an installation location 3
 Accessories 4
 System installation 5
 Indoor unit installation 6
 Outdoor unit installation 9

Refrigerant Pipe Connection
 Refrigerant pipe connection 10

Electrical Work
 Electrical Work 12

Air Purging
 Air purging with vacuum pump 14
 Safety and refrigerant leak check 16

Testing the System
 Test Run 17





Caution

- Contact an authorized service technician for repair or maintenance of this unit.
- Contact an authorized installer for installation of this unit.
- Installation work must be performed in accordance with local and national electrical codes and standards by authorized personnel only.



- Read the follow SAFETY PRECAUTIONS carefully before installation.
- Electrical work must be performed by a licensed electrician. Be sure to use the correct rating of the power cord and main circuit for the model to be installed.
- Incorrect installation due to ignoring the instruction will cause harm or damage.

■ **The seriousness is classified by the following indications.**

 WARNING!	This symbol indicates the possibility of death or serious injury.
 CAUTION!	This symbol indicates the possibility of injury or damage to property.

The items to be followed are classified by the symbols:

	This symbol denotes item that is PROHIBITED from doing.
---	---

 WARNING!	
1)	Do not install without an authorized servicer/installer.
2)	Install according to this installation instruction. If installation is defective, it can cause water leakage, or electrical shock/fire.
3)	Use the supplied accessories and specified parts for installation.
4)	Install the indoor unit on a wall strong enough to hold the unit's weight. Install the outdoor unit on a raised concrete pad or blocks to provide a solid, level foundation. In a location with high winds, anchor the unit and provide an air baffle. In snowy areas (for heat pump models), install the outdoor unit on a raised platform so that it is higher than drifting snow. Provide snow vents.
5)	For electrical work, follow local and national electric codes and these installation instructions. An independent circuit and single outlet must be used. If electrical circuit capacity is not enough or defects are found in electrical work, it will cause electrical shock or fire.
6)	Use the specified cable and connect tightly and clamp the cable so that no external force will stress the terminal. Loose wiring may cause overheating at the connection points and a possible fire hazard.
7)	Wiring routing must be properly arranged so that control board cover is fixed properly. If control board cover is not fixed perfectly, it will cause overheating at connection point of terminal, fire or electrical shock.
8)	When charging the unit, take care not to let air/substances other than the specified refrigerant go into refrigeration cycle. Otherwise, it will cause lower capacity, abnormal high pressure in the refrigeration cycle, explosion and injury.
9)	Do not modify the length of the power supply cord or use an extension cord, and do not share the single outlet with other electrical appliances. Otherwise, it will cause fire or electrical shock.
 CAUTION!	
1)	This equipment must be grounded and installed with a ground leakage current breaker. It may cause electrical shock if grounding work doesn't comply with local/national electric codes.
2)	Do not install the unit at place where leakage of flammable gas may occur. If gas leaks and accumulates near the unit, it may cause fire.
3)	Carry out drainage piping as mentioned in installation instructions. If not done correctly, water may enter the room and damage personal belongings.

1. Wall-mounted type

Selecting installation place

Read completely, then follow step by step.

Indoor unit

- Do not expose the indoor unit to heat or steam.
- Select a place where there are no obstacles in front or around the unit.
- Make sure that condensation drainage can be conveniently routed away.
- Do not install near a doorway.
- Ensure that the space on the left and right of the unit is more than 5in.(12cm).
- Use a stud finder to locate studs to prevent unnecessary damage to the wall.
- The indoor unit should be installed on the wall at a height of 6.5ft.(2m) or more from the floor.
- The indoor unit should be installed allowing a minimum clearance of 6in.(15cm) from the ceiling.
- Any variations in pipe length may require adjustment to refrigerant charge.
- Do not expose unit to direct sunlight. The sun will fade the plastic cabinet and affect its appearance.

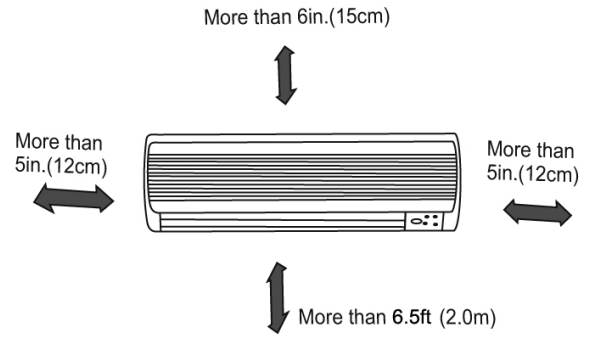

Fig.1

Outdoor unit

- If an awning is built over the outdoor unit to prevent direct sunlight or rain exposure, make sure that heat radiation from the condenser is not restricted.
- Ensure that the clearance around the back of the unit is more than 12in.(30cm) and left side is more than 12in.(30cm). The front of the unit should have more than 79in.(200cm) of clearance and the connection side (right side) should have more than 24in.(60cm)of clearance.
- Do not place animals and plants in the path of the air inlet or outlet.
- Take the air conditioner weight into account and select a place where noise and vibration will not be an issue.
- Select a place so that the warm air and noise from the air conditioner do not disturb neighbors.

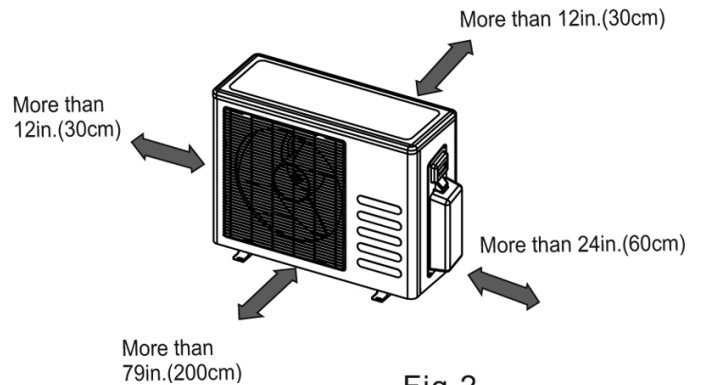

Fig.2

Rooftop installation

- If the outdoor unit is installed on a roof structure, be sure to level the unit.
- Ensure the roof structure and anchoring method are adequate for the unit location.
- Consult local codes regarding rooftop mounting.
- If the outdoor unit is installed on roof structures or external walls, this may result in excessive noise and vibration, and may also be considered a non-serviceable installation.

Tools needed for installation:

Level gauge	
Screwdriver	
Electric drill, Hole core drill (ϕ .25in.(65mm))	
Flaring tool set	
Torque wrench	
Spanner (half union)	
Hexagonal wrench (1.5in.(4mm))	
Gas-leak detector	
	Vacuum pump
	Gauge manifold
	Users manual
	Thermometer
	Multimeter
	Pipe cutter
	Measuring tape

Accessories

Number	Name of Accessories		Qty/unit	
1	Installation Plate		1	
2	Plastic Expansion Sheath		8	
3	Self-tapping Screw A ST3.9X25		8	
4	Seal		1	
5	Drain Joint		1	
6	Connecting pipe Assembly	Liquid side ϕ 1/4" (6.35mm)	Parts you must purchase (The minimum pipe wall-thickness of 0.7mm is required.)	
		Gas side		ϕ 3/8" (9.53mm) (<12,000 Btu/h model)
				ϕ 1/2" (12.7mm) (\geq 12,000 Btu/h model)
7	Remote controller		1	
8	Self-tapping Screw B ST2.9X10		2	
9	Remote controller holder		1	

Note: Except the above parts provided, the other parts needed during installation you must purchase.

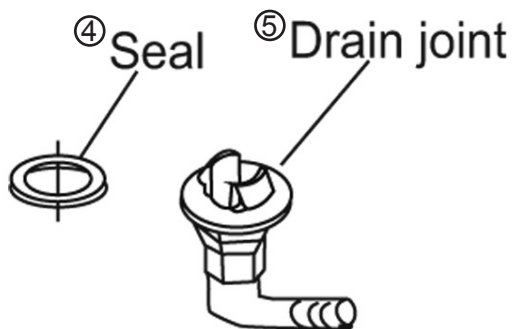

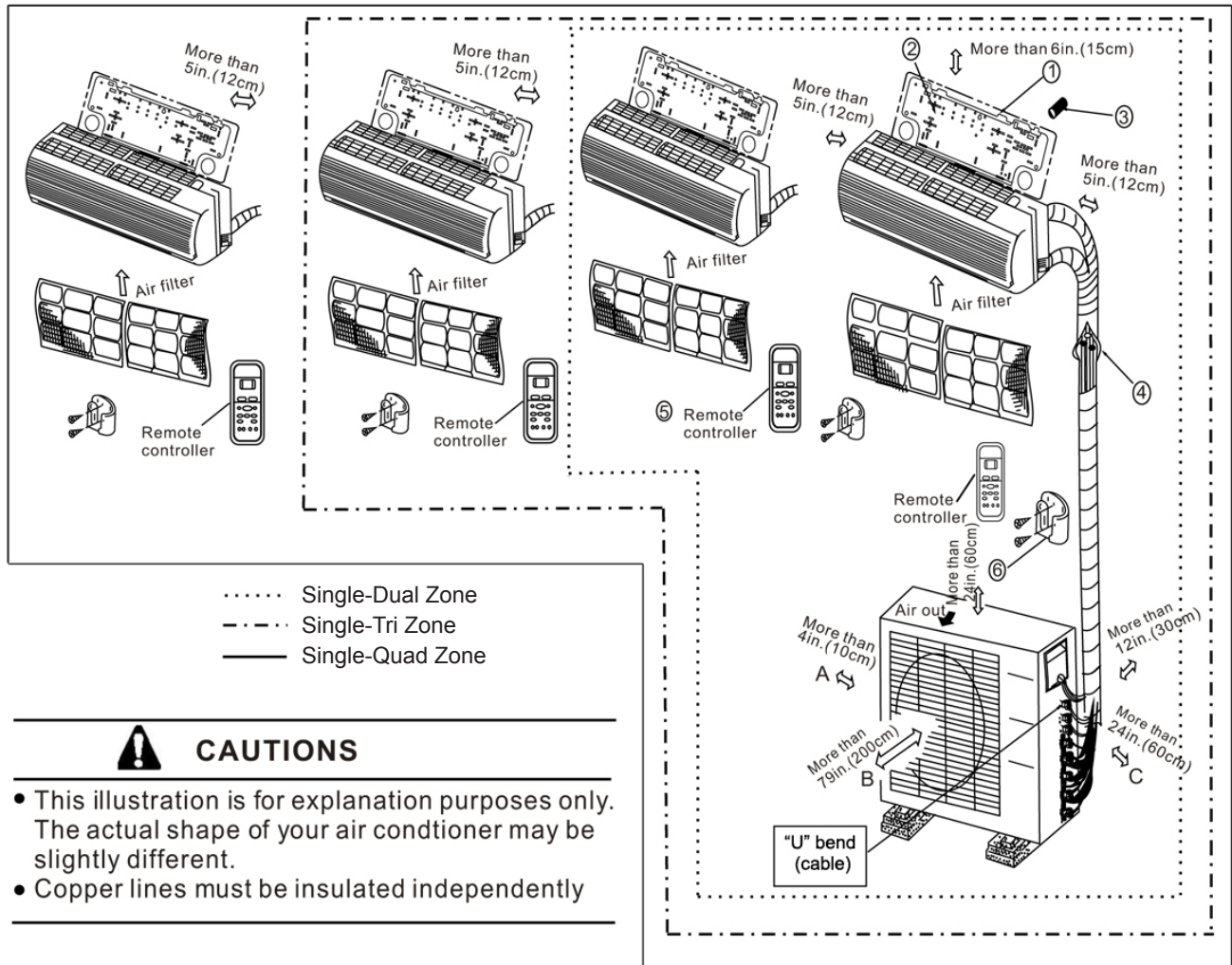

Fig.3

CAUTION

- Use a stud finder to locate studs to prevent unnecessary damage to the wall.
- A minimum pipe run of 9.8 ft (3m) is required to minimize vibration & excessive noise.
- Two of the "A," "B" and "C" air flow directions should be free from obstructions for the outdoor unit.

Indoor unit installation (wall-mounted type)

1. Installation Plate

- A. Mount the installation plate horizontally on structural parts (studs) of the wall with proper clearance around the installation plate.
- B. If the wall is made of brick, concrete or the like, drill eight (8) 5mm (0.2in.) diameter holes in the wall. Insert anchor for appropriate mounting screws.
- C. Fit the installation plate on the wall with eight (8) type "A" screws.

NOTE:

Fit the Installation Plate and drill holes in the wall according to the wall structure and corresponding mounting points on the installation plate. The Installation Plate may be slightly different according to the different models of indoor unit.

Correct orientation of Installation Plate

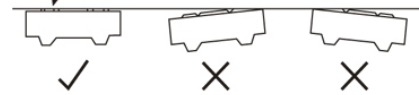
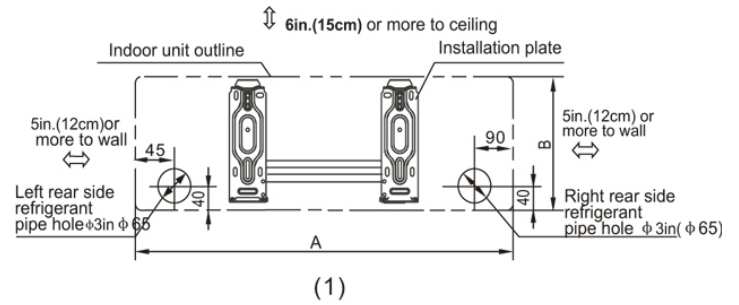
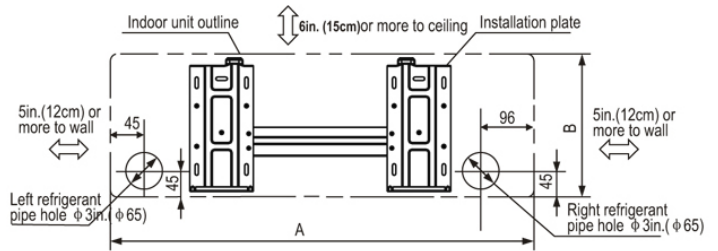

Fig.4



(1)



(2)

Fig.5

Model	A in. (mm)	B in. (mm)
<12,000 Btu/h	28 (710)	10 (250)
	30 (750)	10 (250)
	31 (780)	11 (270)
≥12,000 Btu/h	32 (790)	10 (265)
	31 (780)	11 (270)
	32 (815)	11 (280)

2. Drill a hole in the wall

- A. Determine hole positions according to the diagram detailed in Fig.5. Drill one (1) hole (3in. (65mm)) slanting slightly toward the outdoors, as shown in Fig. 6.
- B. Always use wall hole conduit when drilling metal grid, metal plate or the like.

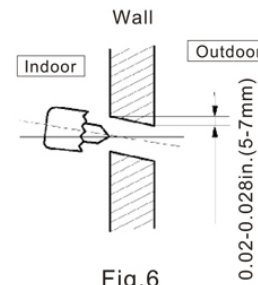

Fig.6

3. Connective Pipe and Drainage Installation

- A. Run the drain hose sloping downward. Do not install the drain hose as illustrated in Fig.7.

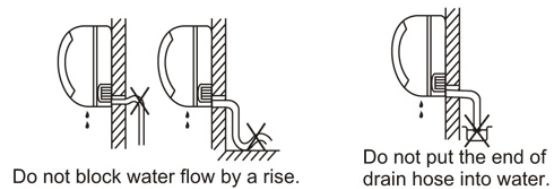

Fig.7

- When connecting extension drain hose, insulate the connecting part of extension drain hose with a shield pipe, do not let the drain hose slack.

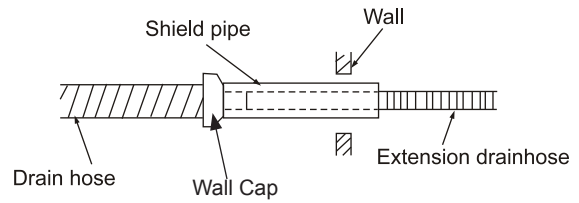

Fig.8

Connective pipe installation

- For the left-hand and right-hand piping, remove the pipe cover from the side panel.
- For the rear-right-hand and rear-left-hand piping, install the piping as shown in Fig.9. Bend the connective pipe to be laid at 4in.(43mm) height or less from the wall.
- Fix the end of the connective pipe. (Refer to Tightening Connection in REFRIGERANT PIPING CONNECTION)

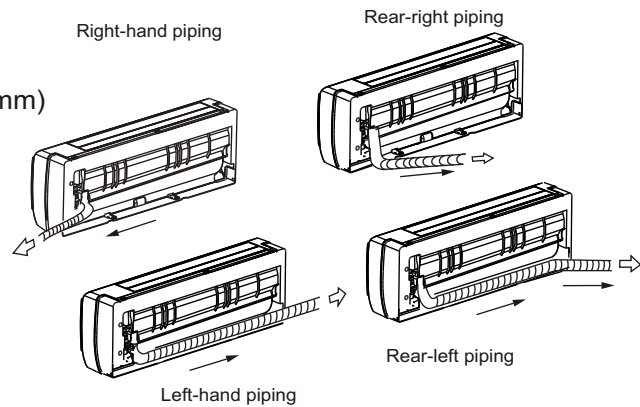

Fig.9

4. Piping and wrapping

Bundle the tubing, connecting cable, and drain hose with tape securely, evenly as shown in Fig.11.

- Because the condensed water from rear of the indoor unit is gathered in ponding box and is piped out of room. Do not put anything else in the box.

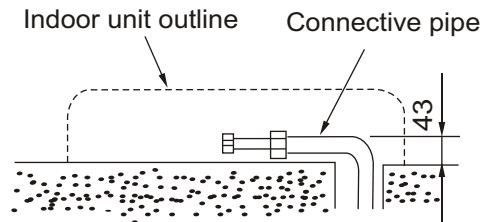

Fig.10

CAUTION

- Connect the indoor unit first, then the outdoor unit.
- Do not allow the piping to let out from the back of the indoor unit.
- Be careful not to let the drain hose slack.
- Heat insulate both of the auxiliary piping.
- Be sure that the drain hose is located at the lowest side of the bundle. Locating at the upper side can cause drain pan to overflow inside the unit.
- Never intercross nor intertwine the power wire with any other wiring.
- Run the drain hose sloped downward to drain out the condensed water smoothly.

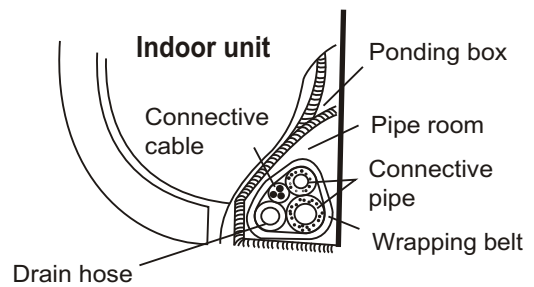

Fig.11

4. Indoor unit installation

1. Pass the piping through the hole in the wall.
2. Put the upper claw at the back of the indoor unit on the upper hook of the installation plate, move the indoor unit from side to side to see that it is securely fastened (see Fig.12).
3. Separate the bottom of the indoor unit from the wall by inserting spacer, etc., between the indoor unit and the wall. Remove spacer after piping is complete.
4. Push the lower part of the indoor unit up on the wall, then move the indoor unit from side to side, up and down to check if it is secure.

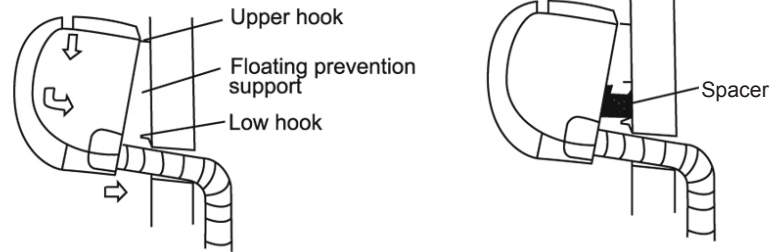

Fig.12

Indoor units can be used in combination	Number of connected units	1-4units
Total length for all rooms		Max. 2400in. (60m) (R-410A)
Length for one indoor unit		Max. 600in. (15m) (R-410A)
Difference in height between indoor and outdoor units	When above outdoor unit (B)	Max.400in.(10m)
	When below outdoor unit (A)	Max.400in.(10m)
Difference in height between indoor units		Max.200in.(5m)
Compressor stop/start frequency	1 cycle time	6 min or more (from stop to stop or from start to start)
	Stop time	3 min or more
Power source voltage	Voltage fluctuation	within $\pm 10\%$ of rated voltage
	Voltage drop during start	within $\pm 15\%$ of rated voltage
	Interval unbalance	within $\pm 3\%$ of rated voltage

Outdoor Unit Installation

Outdoor installation precaution

- Install the outdoor unit on a rigid base to prevent increasing noise level and vibration.
- Determine the air outlet direction where the discharged air is not blocked. If the installation place is exposed to strong winds, ensure the unit is lengthwise along the wall or provide a suitable air baffle.
- If suspending the unit, follow the bracket manufacturer’s instructions.
- Use a raised concrete pad or concrete blocks to provide a solid, level surface. Securely anchor the unit down with bolts.
- Be sure there are no obstacles which block radiating air.
- In a snowy area, install the outdoor unit on a raised platform that is higher than drifting snow.

Anchoring outdoor unit

Anchor the outdoor unit with 5/16" (8mm) or 3/8" (10mm) bolt and nut tightly and horizontally on a concrete or rigid mount.

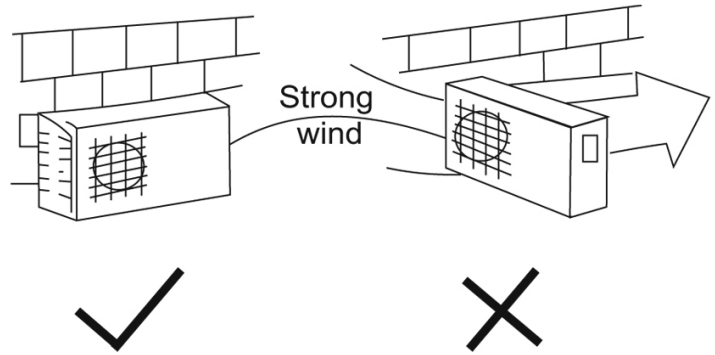

Fig.44

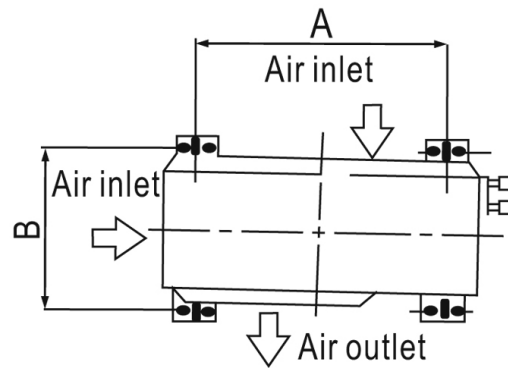

Fig. 45

Outdoor unit dimensions WxHxD in. (mm)	Mounting Dimensions	
	A in. (mm)	B in. (mm)
29.9 x 23.2 x 11.2 (760 x 590 x 285)	20.9 (530)	11.4 (290)
33.3 x 27.4 x 13.2 (845 x 695 x 335)	22 (560)	13.2 (335)
35.2 x 33.9 x 13.0 (895 x 860 x 330)	23.2 (590)	13.1 (333)
39.0 x 38.0 x 14.0 (990 x 965 x 355)	24.5 (623)	14.4 (366)

REFRIGERANT PIPE CONNECTION

Drain joint installation

Fit the seal into the drain elbow, then insert the drain joint into the base pan hole of outdoor unit, rotate 90° to securely assemble them.

Connecting the drain joint with an extension drain hose (locally purchased) is recommended.

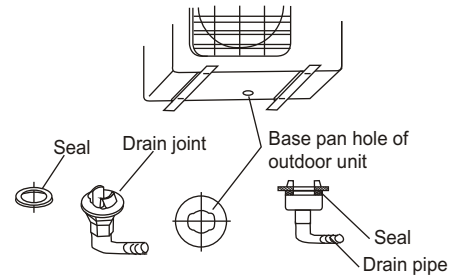

Fig.46

Refrigerant pipe connection

1. Flaring work

Main cause for refrigerant leakage is due to defect in the flaring work. Carry out correct flaring work using the following procedure:

A: Cut the pipes and the cable.

1. Use line set kit or copper tubes/pipes purchased locally.
2. Measure the distance between the indoor and the outdoor unit.
3. Cut the pipes/tubes a little longer than the measured distance.
4. Cut the cable 1.5m longer than the pipe/tube length.

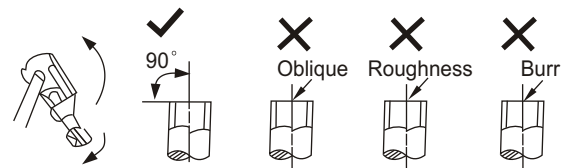

Fig.47

B: Burr removal

1. Completely remove all burrs from the cut cross section of pipe/tube.
2. Put the end of the copper tube/pipe in a downward direction as you remove burrs in order to avoid dropping burrs into the tubing.

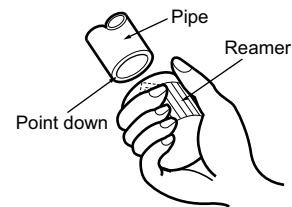

Fig.48

C: Putting nut on

Remove flare nuts attached to indoor and outdoor unit, then put them on pipe/tube having completed burr removal. (not possible to put them on after flaring work)

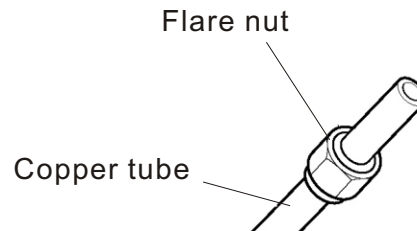

Fig.49

Refrigerant Pipe Connection

D: Flaring work

Firmly hold copper pipe in a die in the dimension shown in the table below.

Outer diameter in. (mm)	A in. (mm)	
	Max.	Min.
φ 1/4" (6.35)	0.5 (1.3)	0.276 (0.7)
φ 3/8" (9.35)	0.63 (1.6)	0.394 (1.0)
φ 1/2" (12.7)	0.709 (1.8)	0.394 (1.0)

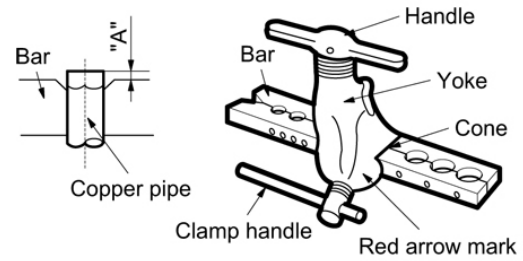

Fig.50

Tightening Connection

- Align the center of the pipes.
- Sufficiently tighten the flare nut with fingers, and then tighten it with a spanner and torque wrench as shown in Fig.51 & 52.

Outer Diameter	Tightening torque	Additional tightening torque
φ 1/4" (6.35)	11.57 ft-lb (160 kgf-cm)	14.46 ft-lb (200 kgf-cm)
φ 3/8" (9.35)	21.69 ft-lb (300 kgf-cm)	25.3 ft-lb (350 kgf-cm)
φ 1/2" (12.7)	36.17 ft-lb (500 kgf-cm)	39.78 ft-lb (550 kgf-cm)

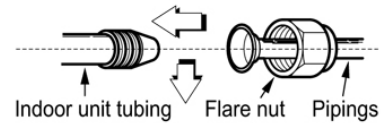

Fig.51

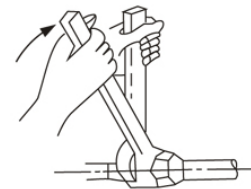

Fig.52

Caution

Excessive torque can break nut depending on installation conditions.

Electrical Work

Electric safety regulations for the initial Installation

1. Power voltage should be in the range of 90%~110%of rated voltage.
2. The creepage protector and main power switch with a 1.5 times capacity of Max. Current of the unit should be installed in power circuit.
3. Ensure the air conditioner is grounded well.
4. Connect wiring to the unit according to the electrical diagram located on the panel of the outdoor unit.
5. All wiring must comply with local and national electrical codes and be installed by qualified and skilled electricians.
6. An individual branch circuit and single receptacle used only for this air conditioner must be available.

CAUTION

- 1) **Never fail to have an individual power circuit specifically for the air conditioner. As for the method of wiring, be guided by the circuit diagram posted on the inside of control cover.**
- 2) **The screws which fasten the wiring in the casing of electrical fittings are liable to come loose from vibrations to which the unit is subjected during the course of transportation. Check them and make sure that they are all tightly fastened. (If they are loose, it could cause burn-out of the wires.)**
- 3) **Specification of power source.**
- 4) **Confirm that electrical capacity is sufficient.**
- 5) **See that the starting voltage is maintained at more than 90 percent of the rated voltage marked on the name plate.**
- 6) **Confirm that the cable thickness is as specified in the power source specification.**
- 7) **Always install an earth leakage circuit breaker in a wet or moist area.**
- 8) **The following would be caused by voltage drop.**
Vibration of a magnetic switch, which will damage the contact point, fuse breaking, disturbance of the normal function of the overload.
- 9) **The means for disconnection from a power supply shall be incorporated in the fixed wiring and have an air gap contact separation of at least 3mm in each active(phase) conductors.**

Electrical Work

Wiring connection

NOTE: Before performing any electrical work, turn off the main power to the system.



CAUTIONS

- Do not touch the capacitor even if you have disconnected the power or electric shock hazard may occur. For your safety, you should start repairing at least 5 minutes after the power is disconnected.
- The power is supplied from the Outdoor Unit. Up to four indoor units are connected with signal wires or power cords.

Connect the cable to the outdoor unit

1. Remove the electrical control board cover from the outdoor unit by loosening the screw as shown in Fig.53.
2. Connect the connective cables to the terminals as identified with their respective matched numbers on the terminal block of indoor and outdoor units.
3. Secure the cable onto the control board with the cord clamp.
4. To prevent rain water from running along the connective cable to the inside of the buiding/ room where the unit is located, make a "U" bend trap.
5. Insulate unused cords (conductors) with PVC-tape. Ensure that they do not touch any electrical or metal parts.

Minimum nominal cross-sectional area of conductors:

Rated current of appliance (A)	Nominal cross-sectional area (mm ²)
>3 and ≤6	0.75
>6 and ≤10	1
>10 and ≤16	1.5
>16 and ≤25	2.5

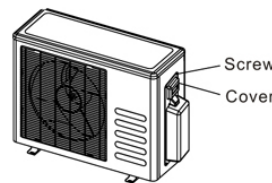

Fig.53

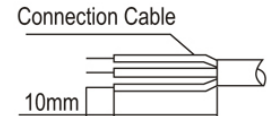

Fig.54

Terminal block of outdoor unit

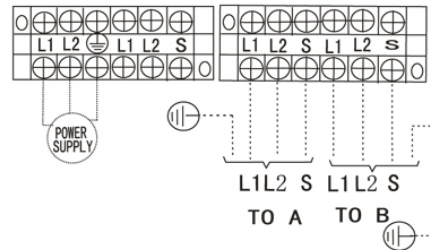

Fig.55

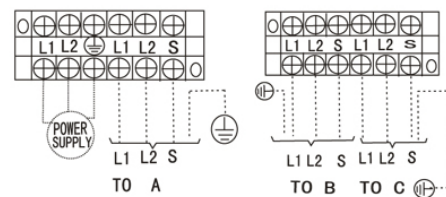

Fig.56



CAUTIONS

Make sure to connect the indoor unit (A,B, C, D) to the Hi and Lo valve and terminals of signal wires(A, B, C, D) of outdoor unit as identified with their respective matched connection. Wrong wiring connections may cause some electrical parts to malfunction.

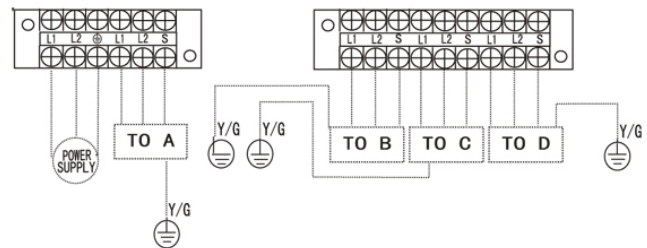

Fig.57

Air Purging

Air and moisture in the refrigerant system have undesirable effects as indicated below:

- Pressure in the system rises.
- Operating current rises.
- Cooling or heating efficiency drops.
- Moisture in the refrigerant circuit may freeze and block capillary tubing.
- Water may lead to corrosion of parts in the refrigeration system.

Therefore, the indoor unit and tubing between the indoor and outdoor unit must be leak tested and evacuated to remove any noncondensables and moisture from the system.

Air purging with vacuum pump

Preparation

- Check that each tube(both liquid and gas side tubes) between the indoor and outdoor units have been properly connected and all wiring for the test run has been completed. Remove the service valve caps from both the gas and the liquid side on the outdoor unit. Note that both the liquid and the gas side service valves on the outdoor unit are kept closed at this stage.
- Pipe length and refrigerant amount:

Connective Pipe Length	Air Purging Method	Additional amount of refrigerant to be charged
Less than 16.5 ft. (5m)	Use vacuum pump	_____
More than 16.5 ft. (5m)	Use vacuum pump	(Pipe length-5m) 15g/m (Pipe length-16.5 ft.) x 5 oz/ft.

Air Purging

- When relocating the unit to another place, perform evacuation using vacuum pump.
- Make sure the refrigerant added into the air conditioner is liquid form.

Caution in handling the packed valve

- Open the valve stem until it hits against the stop. Do not try to open it further.
- Securely tighten the valve stem cap with a spanner or the like.
- Valve stem cap tightening torque (see tightening torque table).

When Using the Vacuum Pump

(For method of using a manifold valve, refer to its operation manual.)

1. Completely tighten the flare nuts, A, B, C, D, connect the manifold valve charge hose to a charge port of the low-pressure valve on the gas pipe side.
2. Connect the charge hose connection to the vacuum pump.
3. Fully open the Lo handle of the manifold valve.
4. Operate the vacuum pump to evacuate. After starting evacuation, slightly loose the flare nut of the Lo valve on the gas pipe side and check that the air is entering (Operation noise of the vacuum pump changes and a compound meter indicates 0 instead of minus)
5. After the evacuation is complete, fully close the Lo handle of the manifold valve and stop the operation of the vacuum pump. Evacuate for 15 minutes or more and check that the compound meter indicates -29.92 inHg (-1x105Pa).
6. Turn the stem of the packed valve B about 45° counterclockwise for 6~7 seconds after the gas comes out, then tighten the flare nut again. Make sure the pressure display in the pressure indicator is a little higher than the atmosphere pressure.
7. Remove the charge hose from the Low pressure charge hose.
8. Fully open the packed valve stems B and A.
9. Securely tighten the cap of the packed valve.

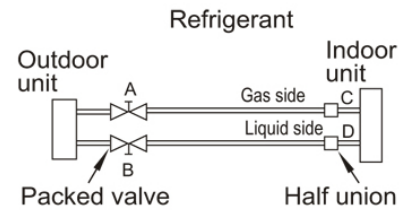

Fig.60

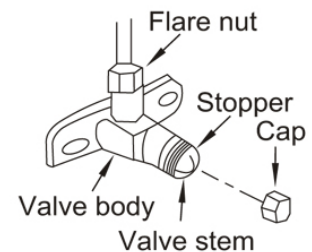

Fig.61

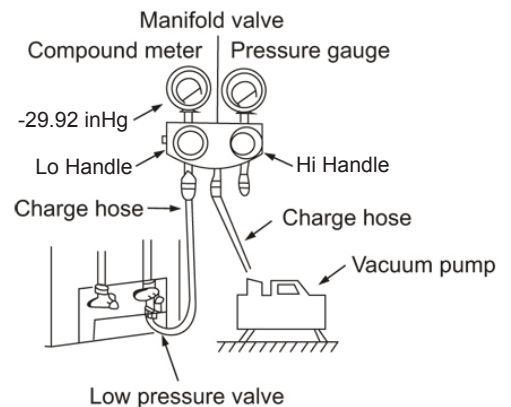

Fig.62

Air Purging

Safety and Leak Check

● Electrical safety check

Perform the electric safe check after completing installation:

1. Insulated resistance
The insulated resistance must be more than $2M \Omega$.
2. Grounding work
After finishing grounding work, measure the grounding resistance by visual detection and grounding resistance tester. Make sure the grounding resistance is less than 4Ω .
3. Electrical leakage check (performing during test run).
During test operation after finishing installation, the serviceman can use the electroprobe and multimeter to perform the electrical leakage check. Turn off the unit immediately if leakage happens. Check and find out the solution ways till the unit operate properly.

● Refrigerant Leak Check

1. Soap water method:

Apply a soap water or a liquid neutral detergent on the indoor unit connection or outdoor unit connections with a soft brush to check for leakage of the connecting points of the piping. If bubbles come out, the pipes have leakage.

2. Leak detector

Use the leak detector to check for leakage.

CAUTION

A: Lo packed valve B: Hi packed valve
C and D are ends of indoor unit connection.

NOTE: The illustration is for explanation purposes only. The actual order of A, B, C and D on the machine may be slightly different from the unit you purchased. The actual shape shall prevail.

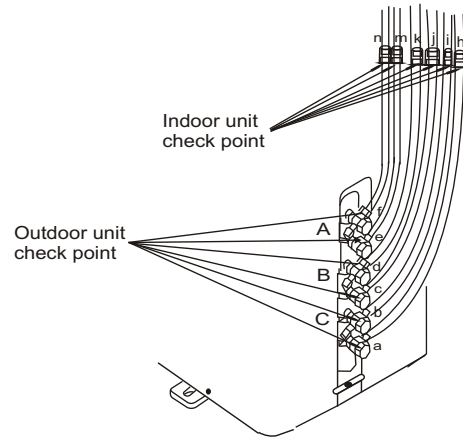

a,b,c,d,h,i,j , k are points for one-two type.
a,b,c,d,e,f,,h,i,j,k,m,n are points for one-three type.

Fig.63

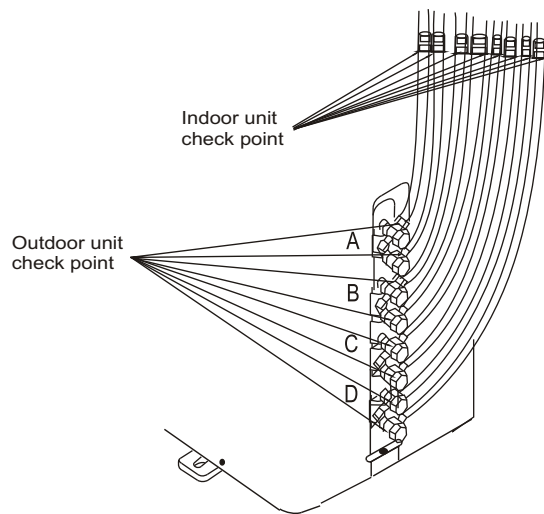

One-four type

Fig.64

Testing the System

Perform test operation after completing gas leak check at the flare nut connections and electrical safety check.

- Check that all tubing and wiring have been properly connected.
 - Check that the gas and liquid side service valves are fully open.
1. Connect the power, press the ON/OFF button on the remote controller to turn the unit on.
 2. Use the MODE button to select COOL, HEAT, AUTO and FAN to check if all the functions work well.
 3. When the ambient temperature is too low(lower than 62.2°F (17°C)), the unit cannot be controlled by the remote controller to run in cooling mode, manual operation can be used. Manual operation is used only when the remote controller is disable or maintenance necessary.
 - Hold the panel sides and lift the panel up to an angle until it remains fixed with a clicking sound.
 - Press the Manual control button to select the AUTO or COOL, the unit will operate under Forced AUTO or COOL mode(see User Manual for details).
 4. The test operation should last about 30 minutes.

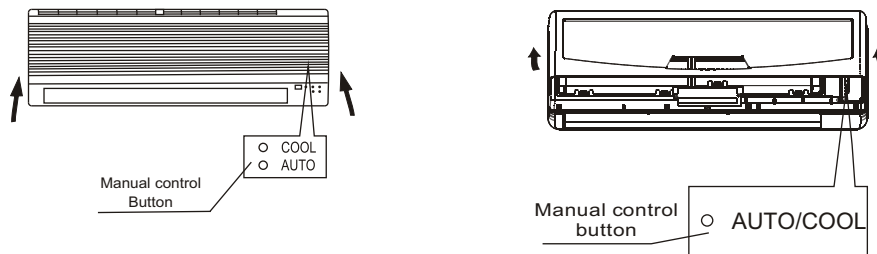

Fig.65

Design, material, performance data and components
subject to change without notice.

HEAT CONTROLLER, INC.

1900 Wellworth Ave., Jackson, MI 49203 ♦ Ph. 517-787-2100 ♦ Fax 517-787-9341

THE QUALITY LEADER IN CONDITIONING AIR

www.heatcontroller.com