

YORK[®] FITNESS

Owner's Manual

7000 Series X-I XTrainer

Item #52065

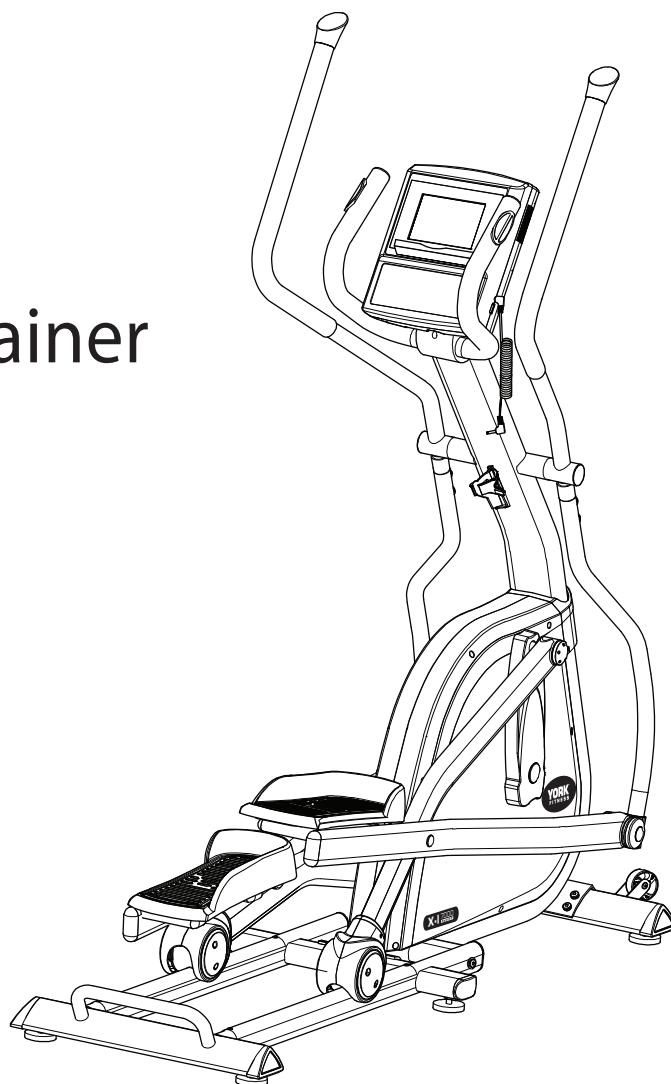

March 6, 2014

Table of Contents

Congratulations on purchasing your exercise equipment from



You have chosen a high quality, safe and innovative piece of equipment as your training partner and we are certain it will keep you motivated on the way to achieving your personal fitness goals.

Please take the time to read this owner's manual as it will help you to get the most out of your new exercise equipment.

For more information visit www.yorkfitness.com

CONTENTS

Safety information	03
Customer support	04
Assembly Instructions	05
Operational Instructions	12
Troubleshooting	16
Fitness Guide	18
Exploded Drawing	20
Part List	22



Protect the environment by not disposing of this product or batteries with household waste. Check your local authority for recycling advice and facilities.

Safety Information

Please read this instruction manual before you begin assembly. Great care has been taken to design these instructions and following them will help you with quicker assembly and minimize the risk of injury.

It is important that you keep these instructions for future reference.

This list is not exhaustive - You are responsible for your own safety!

- Always assemble and operate the equipment on a level surface.
- Ensure the equipment is stable before use.
- Always ensure that the equipment has adequate space on each side.
- The safety level of this equipment can only be maintained if it is regularly examined for wear and tear.
- Replace defective components immediately and keep the equipment out of use until it is repaired.
- Use only the adjustment setting as described in the instructions. Always use the correct adjustment pin / fixing.
- Always check that any pins / fixings are tight and secure before use and after adjustment.
- Never leave any adjustment devices projecting from the equipment.
- Always consult your doctor before undertaking any exercise program.
- Always wear suitable clothing and footwear. (e.g. tracksuit / shorts / training shoes)
- Remove all personal jewelry before exercising.
- Ensure you warm-up well before using the equipment as this will help to prevent muscle strain.
- After eating, allow 1-2 hours before exercising as this will help to prevent muscle strain.
- Never overload the equipment. (See maximum user weight)
- Never use the equipment in any other manner other than the ways explained in these instructions and any wall-chart supplied.
- Injuries to health may result from incorrect or excessive training.
- Parents and others in charge of children should be aware of their responsibility, because the natural play instinct and the fondness of experimenting of children can lead to situations and behavior for which the training equipment is not intended.

- If children are allowed to use the equipment, their mental and physical development and above all their temperament should be taken into account. They should be controlled and instructed in the correct use of the equipment.
- The equipment is under no circumstances suitable as a children's toy.
- Children should not be allowed on or around the equipment, especially when it is not in use.
- This appliance is not intended for use by persons (including children) with reduced physical, sensory or mental capabilities, or lack of experience and knowledge, unless they have been given supervision or instruction concerning use of the appliance by a person responsible for their safety.
- This product is not suitable for therapeutic purposes.
- This product has been tested for use in a home environment and is warranted for In Home, personal, family or household use.
- Due to our continuous policy of product development, York Fitness reserves the right to change specifications without notice.

CAUTION! The instructions must be followed carefully in the assembly, use and maintenance of your equipment. The warranty does not cover damage due to negligence of the assembly, adjustment and maintenance instructions described herein.

Maximum user weight: 180kg

Safety Standards

This equipment meets the requirements of the EU's EMC and Low Voltage directives (where applicable), CLASS SB EN957-1: 2005&EN957-9:2003. Therefore the equipment carries the following marks:



Customer Support

Should you require any assistance regarding this product please gather the following information and then contact us using the details below:

- Serial No. - This can be found on the sticker below, located as indicated.
- Original purchase date
- Place of purchase
- Information about the place and conditions of use
- Precise description of the issue / defect

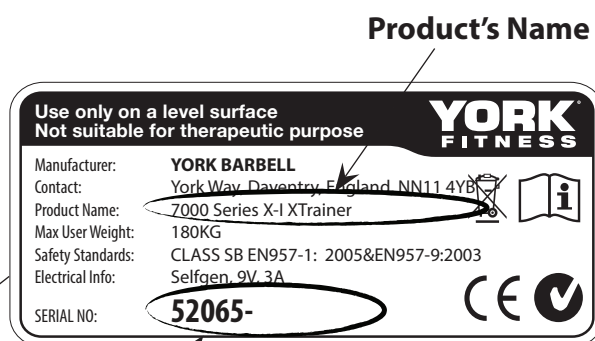
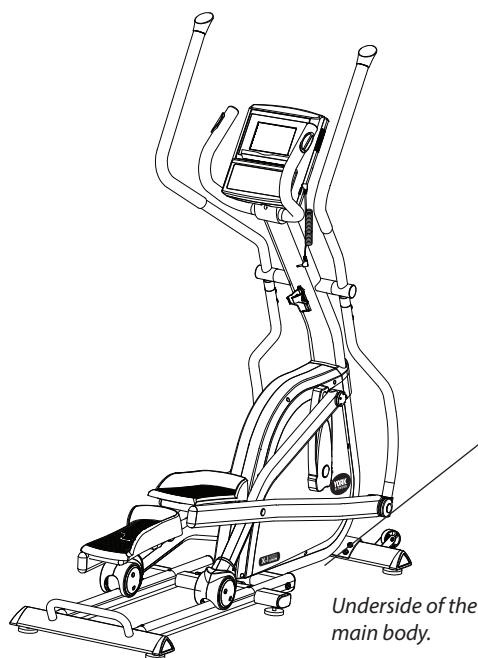

Serial Number

This product label is an example only, it is not the real product name and serial number of the item you have bought.

IMPORTANT!! - Please retain your sales receipt, York Fitness Customer Care may request proof of purchase to validate eligibility for warranty service. Warranty cover starts from the date shown on the proof of purchase.

ENGLAND

The best way to contact us is via the website:
www.yorkfitness.com

York Barbell UK Ltd.

York Way, Daventry,
England, NN11 4YB
Tel: 0844 225 3112

AUSTRALIA

The best way to contact us is via the website:
www.yorkfitness.com.au

York Fitness Australia

1/2 Swaffham Rd, Minto,
PO Box 5130, NSW 2566
Tel: 1800 730 149

PREPARE YOUR WORK AREA - It is important you assemble the product in a clean and uncluttered space.





WORK WITH A FRIEND - We recommend you have someone assist you with the assembly as some of the components are quite heavy.

OPEN THE CARTON - Check any warnings on the carton and make sure you have it the right way up.

UNPACK THE CARTON - Remove all the parts and lay them out on the floor.

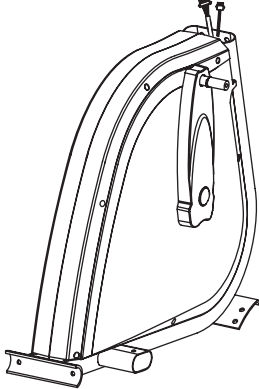
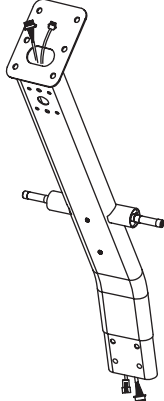
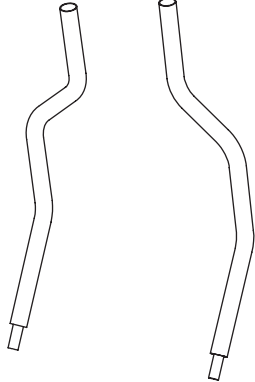
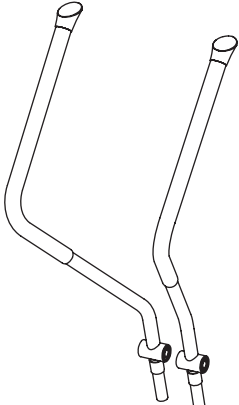
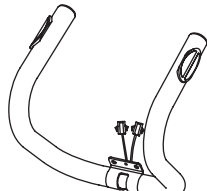
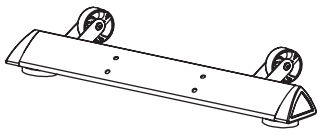
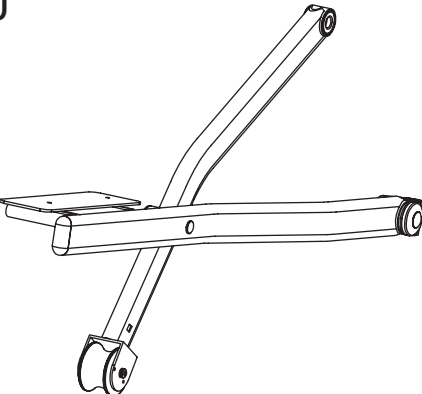
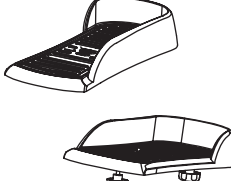
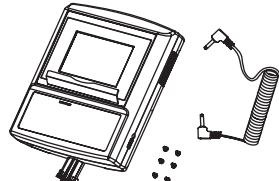
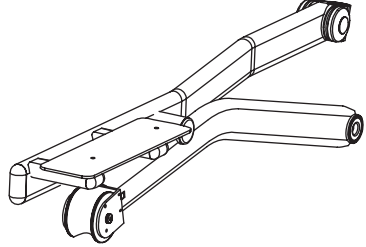
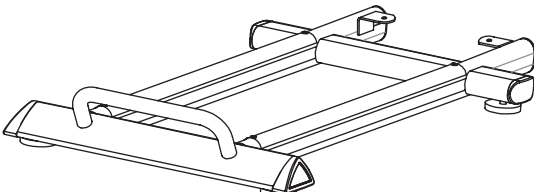
Assembly Instructions

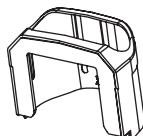
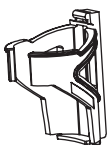
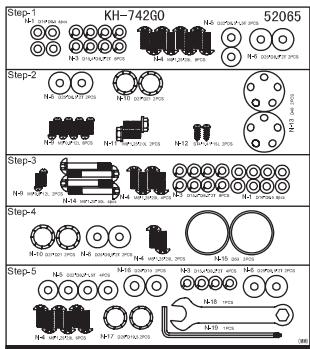
Make sure you have the following parts:

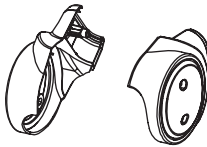
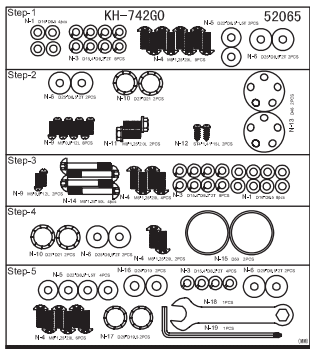
<p>Z</p> 	<p>C</p> 	<p>F</p> 
<p>E</p> 	<p>B</p> 	<p>G</p> 
<p>J</p> 	<p>K</p> 	<p>A</p> 
<p>I</p> 	<p>H</p> 	<p>O</p> 
<p>U</p> 	<p>T</p> 	<p>N</p> 
<p>V</p> 	<p>R</p> 	<p>N</p> 

Assembly Instructions

BLISTER PACK

1

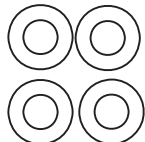

N-1 x 4
(D16*D8.5)



N-3 x 8
(D15.4*D8.2*2T)

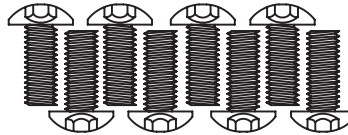

N-4 x 8
(M8*1.25*20L)

N-5 x 2
(D25*D8.5*1.5T)

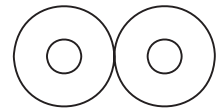

N-6 x 2
(D25*D8.5*2T)

2

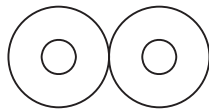

N-6 x 2
(D25*D8.5*2T)

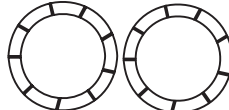

N-10 x 2
(D27*D21)

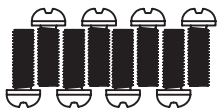

N-9 x 8
(M5*0.8*12L)

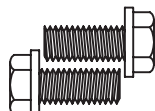

N-11 x 2
(M8*1.25*20L)



N-12 x 2
(ST4*1.41*15L)

N-13 x 2
(D46)

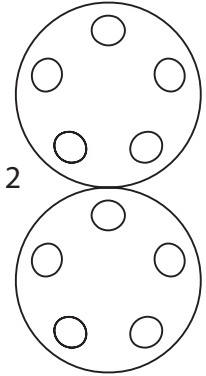

3



N-9 x 2
(M5*0.8*12L)

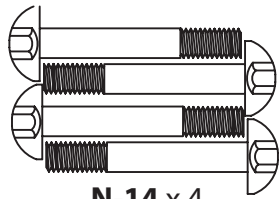

N-14 x 4
(M8*1.25*50L)



N-4 x 4
(M8*1.25*20L)



N-3 x 8
(D15.4*D8.2*2T)

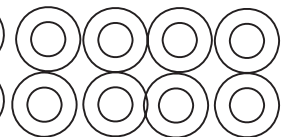

N-1 x 8
(D16*D8.5)

4

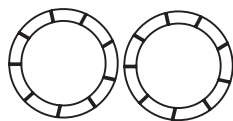

N-10 x 2
(D27*D21)

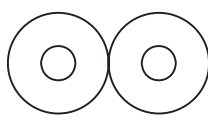

N-6 x 2
(D25*D8.5*2T)

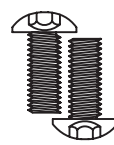

N-4 x 2
(M8*1.25*20L)

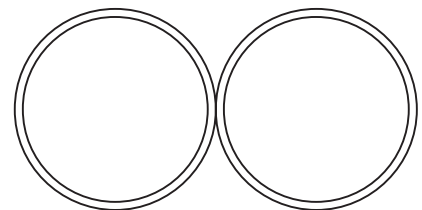

N-15 x 2
(D50)

5



N-5 x 4
(D22*D8.5*1.5T)



N-16 x 2
(D24*D10)



N-3 x 4
(D15.4*D8.2*2T)



N-6 x 2
(D25*D8.5*2T)

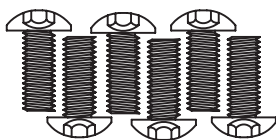

N-4 x 6
(M8*1.25*20L)

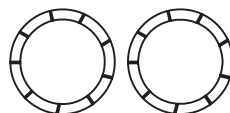

N-17 x 2
(D26*D19.5)

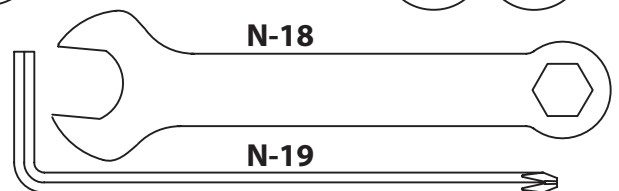

N-18

N-19

1

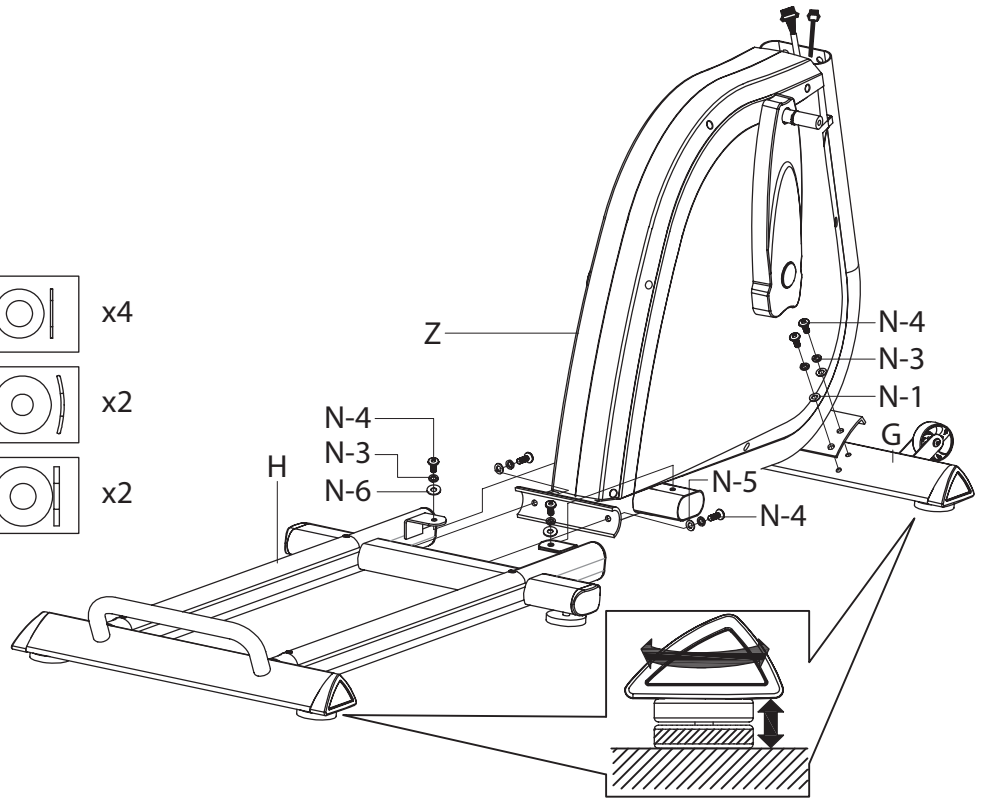
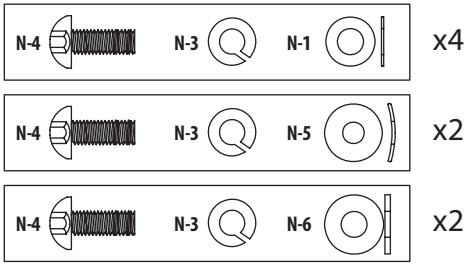

2

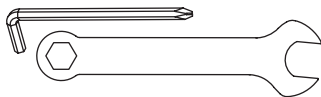

N-12 x 2 N-9 x 8

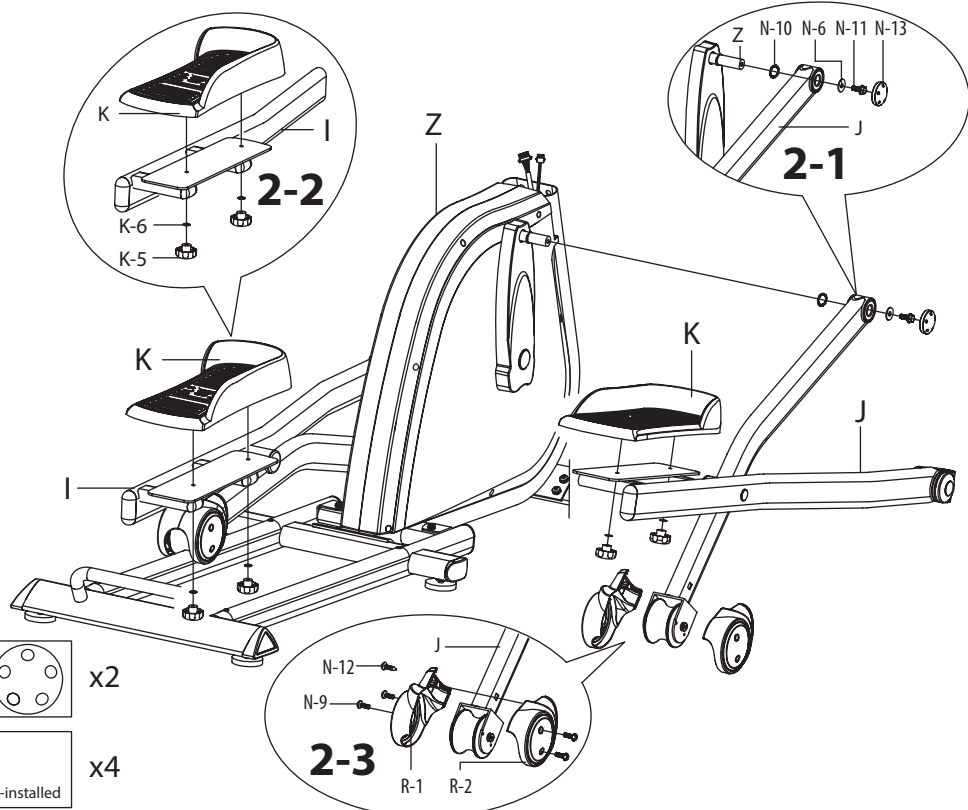
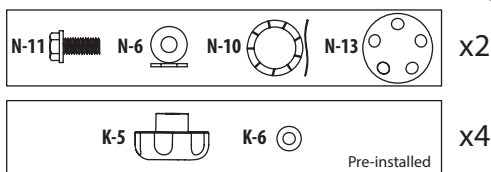

Assembly Instructions

3

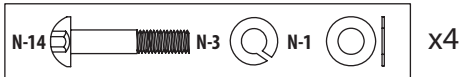
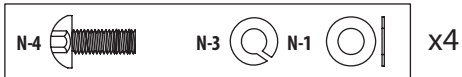
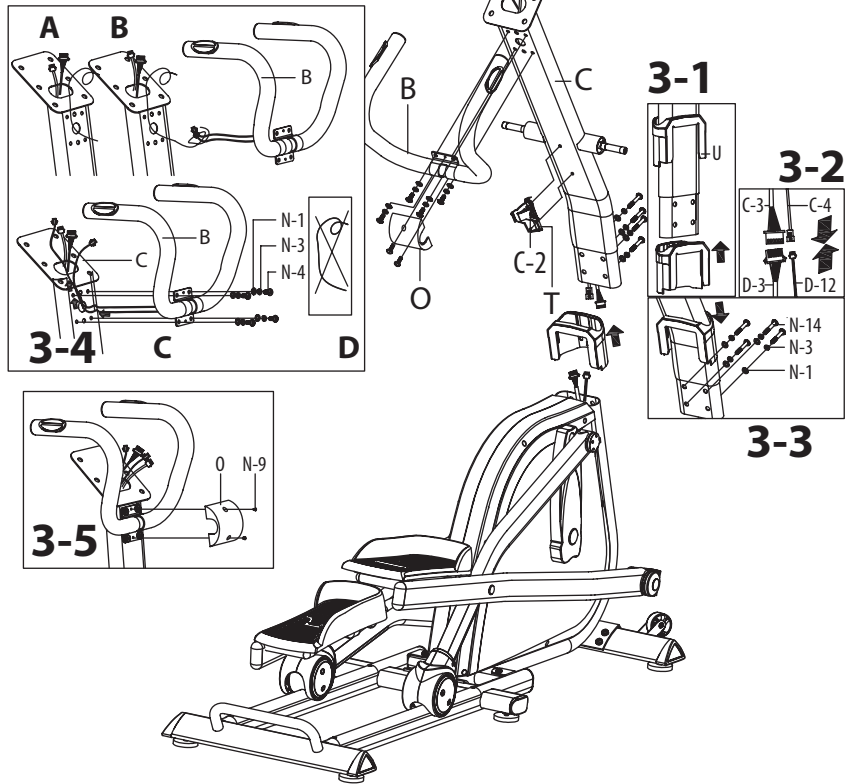

N-9 x 2

4

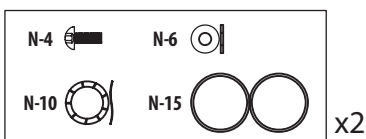
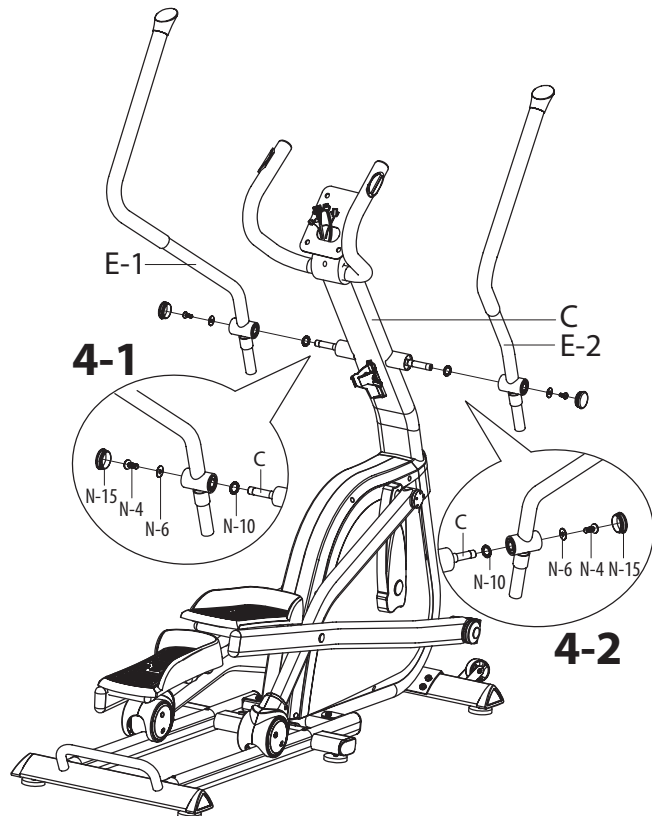

5

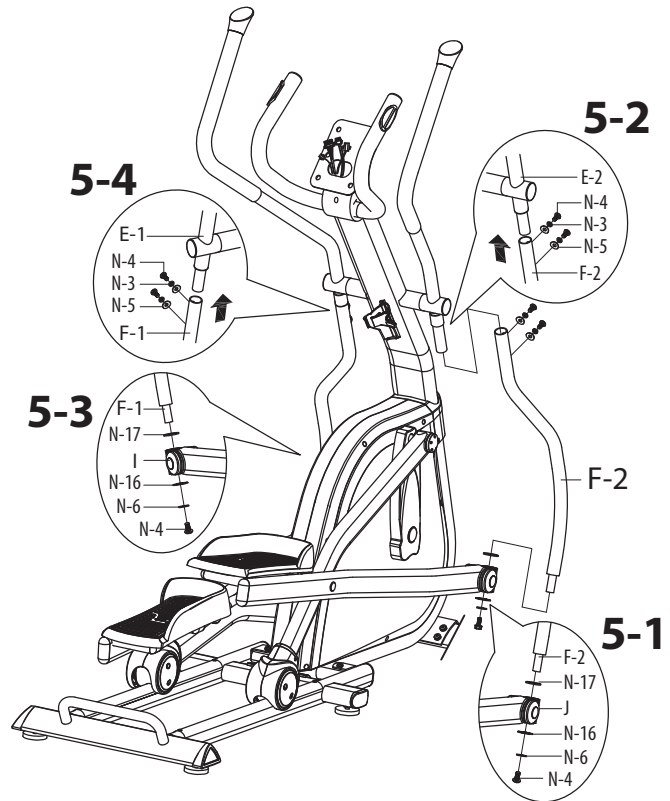
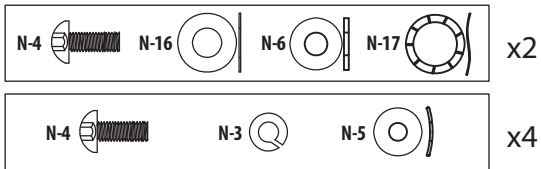
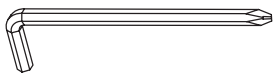

6

A-2 x 6
Pre-installed

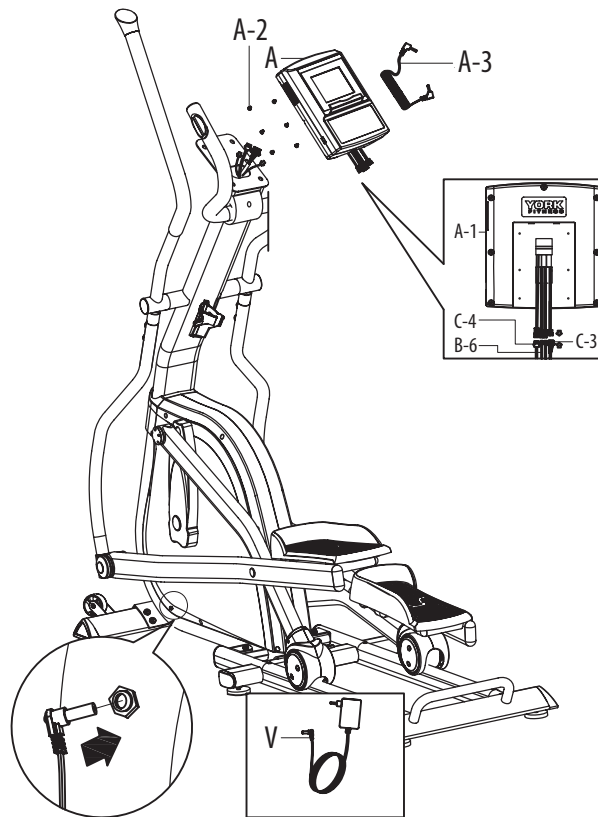

Assembly Instructions

Final Check

Your equipment is now assembled. Please make the following final checks:

- Make sure all screws / bolts are tightened.
- Make sure the equipment is on a flat, level surface.

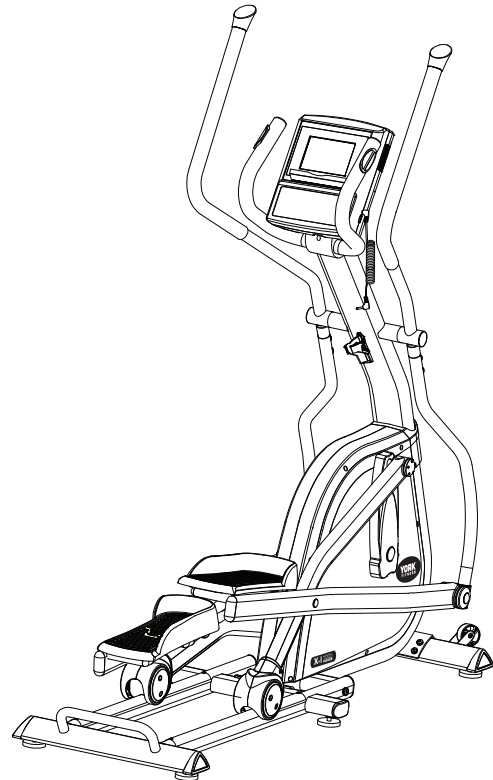

Care & Maintenance

- This equipment should not be placed outdoors, in a garage or an outbuilding. Keep the equipment in a dry place with as little temperature variation as possible.
- We recommend placing a mat beneath the equipment to protect both the equipment and your flooring.
- Always place the equipment in a dry environment.
- Use a warm, damp cloth to keep the product clean.
- No wet cleaning of electrical components. Unplug before any care and maintenance.
- The safety level of the equipment can be maintained only if it is regularly examined for damage and wear. This includes any ropes, pulleys, nuts, bolts, moving parts, bushes, chains, wheels, bearings & connection points etc.
- Ensure that you inspect the product regularly - at least once a week is recommended.
- Ensure that all fixings are tight before use.
- Always replace damaged / worn components with original parts from the manufacturer.

Batteries Replacement Instructions:

WARNING: The equipment use NiMH batteries. Using other types of batteries during charging will damage the equipment.

DO NOT USE ALKALINE BATTERIES IN THIS PRODUCT.

1. Open the battery compartment under the cross trainer.
2. Remove batteries.
3. Insert 7.4V, 1300mAh Li-ion batteries ensuring you match the polarity markings (+ and -) on the batteries with the indicators in the battery compartment. Push flat end (-) against spring and when clear push other end into holder.
4. Close the battery compartment.

Tips & Warnings

- Always change all the batteries at the same time.
- Always use the same type of batteries.
- Never recharge Alkaline AA batteries.
- Do not try to heat, ignite, disassemble or throw AA batteries into a fire.

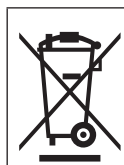

Protect the environment by not disposing of this product or batteries with household waste. Check your local authority for recycling advice and facilities.

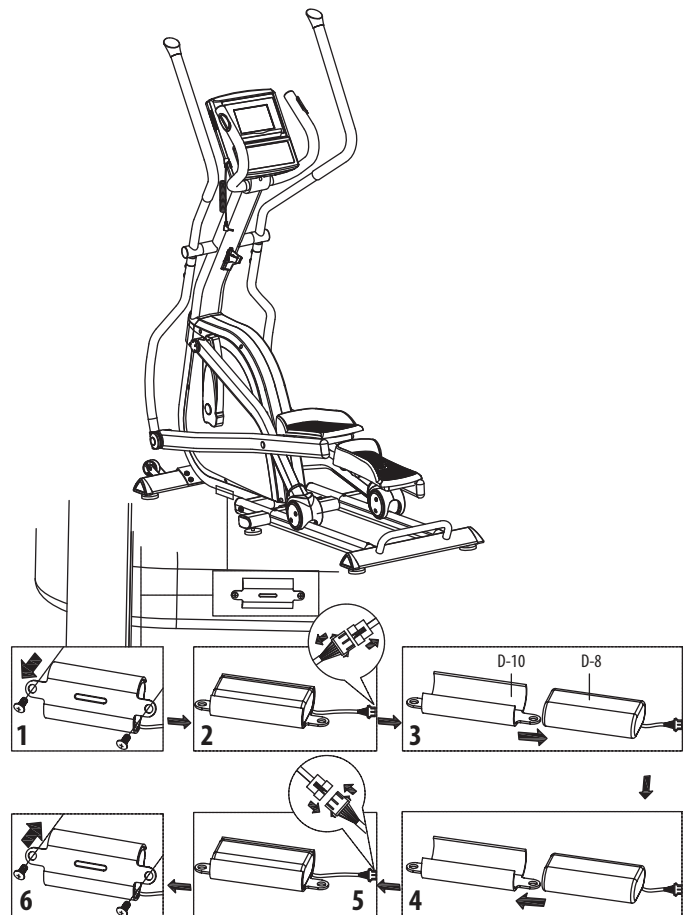

Operational Instructions

Console:

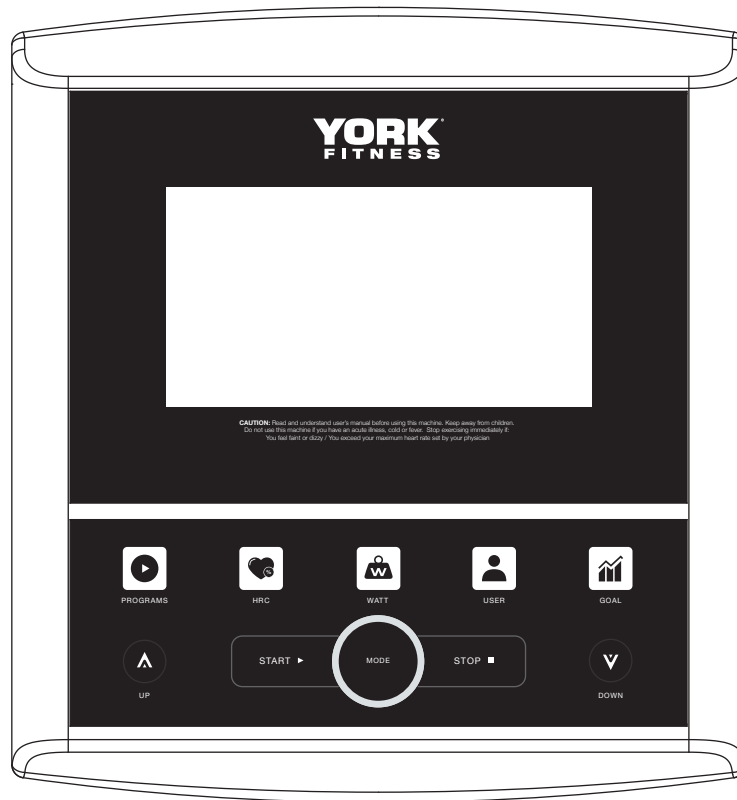

Key Function:

KEYS	FUNCTIONS
MODE	<ul style="list-style-type: none"> Confirm setting or selection Lock workout value scan function during workout
START	<ul style="list-style-type: none"> Start workout
STOP	<ul style="list-style-type: none"> Pause or Stop the training Press and hold "STOP" key for 2 seconds to back to IDLE MODE When the parameter is set, this key to return to the previous option set
LEVEL UP/DOWN	<ul style="list-style-type: none"> During program setup, press UP/DOWN key to adjust the following: Time / Distance / CALORIE / LEVEL profile /WATT/ AGE / WEIGHT / Gender/THR PCT After program started, press UP/DOWN key to adjust the resistance level. level adjustment = 1
PROGRAMS	<ul style="list-style-type: none"> Press PROGRAMS key to select PROGRAM P 1~P 12
HRC	<ul style="list-style-type: none"> Press HRC key to select THR 60 PCT, THR70 PCT, THR 80 PCT, THR 70 PCT
WATT	<ul style="list-style-type: none"> Press WATT key to select WATT MODE
USER	<ul style="list-style-type: none"> Press USER key to select USER U 1~ U 7
GOAL	<ul style="list-style-type: none"> Press GOAL key to select GOAL MODE

Display:

DISPLAY	DESCRIPTION
SCAN	<ul style="list-style-type: none"> When Scan is activated will show the data in order: Level, Watt, Distance, Calorie, Scan icon will be on when Scan mode is activated. Scan mode in which each of the four pieces of data will display for 3 seconds, then switch to the next set of data
TIME	<ul style="list-style-type: none"> Workout time displayed or time countdown during exercise. Setting range 0:00 ~ 99:00(MINUTES)
DISTANCE (DIST.)	<ul style="list-style-type: none"> Workout distance displayed or distance countdown in goal mode. Setting range 0.0 ~ 99.9(KM)
CALORIE (CAL.)	<ul style="list-style-type: none"> Burned calories during workout display or calories countdown in goal mode. Setting range 10 ~ 9990(CAL)
SPEED	<ul style="list-style-type: none"> Workout speed displayed during exercise. Display range 0.0~99.9(KPH)
RPM	<ul style="list-style-type: none"> Workout revolutions per minute displayed during exercise. Display range 0~999
LEVEL	<ul style="list-style-type: none"> Workout resistance level Setting range 1 ~ 40
WATT	<ul style="list-style-type: none"> Workout watt displayed during exercise Setting range 50~350
PULSE	<ul style="list-style-type: none"> Pulse bpm displayed during exercise Heart signal twinkle Display range:0~220(BPM) No pulse bpm displayed "P"

Power On

Plug in power supply and the computer will power on and display all segments for 2 seconds. MW will show "YORK FITNESS" one time, Then press UP/DOWN key to set Gender>Age>Weight when the user power on the monitor for the first time.

General Saving Mode

1. The LCD monitor will into General Saving mode after 5 minutes of inactivity.
2. Press on any key or detect the speed signal input to wake the monitor.

Idle Mode

Dot Matrix window cyclically to display program profile. The text of the flow display "SELECT PROGRAM OR QUICK START". When pause and stop the machine, after 5 minutes of inactivity into to IDLE mode.

Operational Instructions

Quick Start

1. Press START key to begin workout.
2. Press UP / DOWN key to adjust resistance level profile.
3. Press STOP key to pause workout. And again press the STOP key to stop the machine.

Goal Mode

1. Press GOAL key to select GOAL mode and press MODE key to confirm.
2. Press UP / DOWN key to set Time > Distance > Calorie. Press the START KEY after setting (The last setting items for the effective setting).
3. Press START key to accept current default values and begin workout.
 - Default TIME = 20 minutes
 - Default LEVEL = 1
4. Press UP / DOWN key to adjust resistance level profile.
5. Press STOP key to pause workout. And again press the STOP key to stop the machine.

Programs Mode

1. Press PROGRAMS key to select preset program (P 1~P 12) and press MODE key to confirm.
2. Press UP/DOWN key to set Time. And press MODE key to confirm.
3. Press START key to accept current default values and begin workout.
 - Default TIME = 20 minutes
 - Default profile= LEVEL Profile
4. Press UP / DOWN key to adjust resistance level profile.
5. Press STOP key to pause workout. And again press the STOP key to stop the machine.

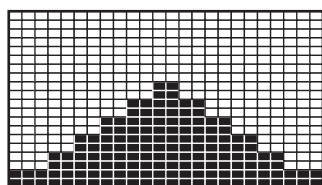

P1

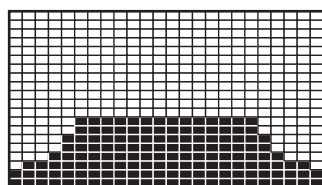

P2

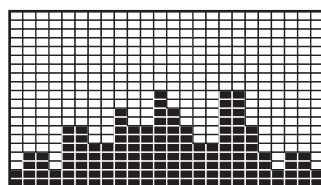

P3

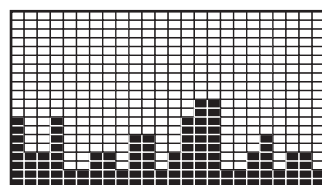

P4

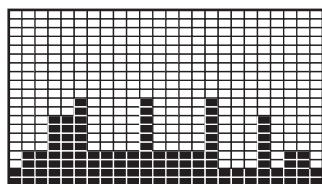

P5

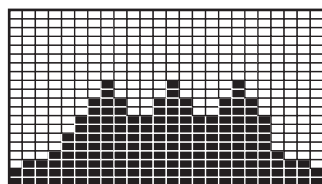

P6

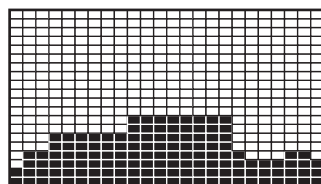

P7

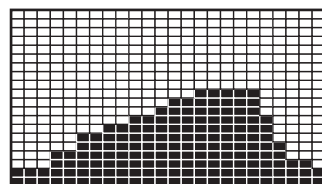

P8

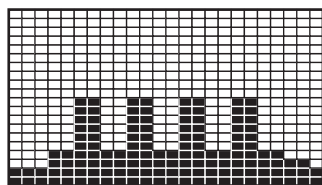

P9

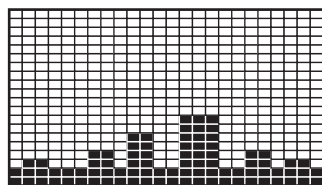

P10

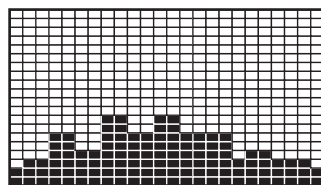

P11

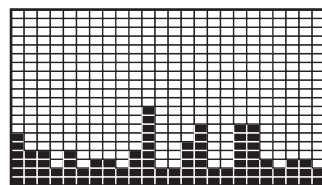

P12

Watt Mode

1. Press WATT key to select WATT mode and press MODE key to confirm.
2. Press UP / DOWN key to set Time > Target Watt value. And press MODE key to confirm each setting.
3. Press START key to start workout.
4. Press UP / DOWN key to adjust target WATT value.
5. Press STOP key to pause workout. And again press the STOP key to stop the machine.

User Mode

1. Press USER key to select USER U 1-U 7, and press MODE key to confirm.
2. Press UP / DOWN key to set Gender>Age>Weight>Time, and press MODE key to confirm each setting.
3. Press UP / DOWN key to set resistance level of each column and press MODE key to select the next column. Repeat this step for all 24 columns.
4. Press START key to start workout.
5. Press UP / DOWN key to adjust resistance level profile.
6. Press STOP key to pause workout. And again press the STOP key to stop the machine.

HRC Mode, HRC wireless receiver built-in with chest belt

1. Press HRC key to select H1: THR 60 PCT, H2: THR 70 PCT, H3: THR 80 PCT and H4: THR 70 PCT
2. Press UP / DOWN key to set PCT(This pct entry is for H4 only), THR 70 will blink(70 is the default PCT) and the user may press UP/DOWN key to set new pct.
3. Press START key to start workout. If user presses start and a chest strap HR is not received then the MW displays "CHEST STRAP MUST BE WORN FOR THIS PROGRAM". If user presses start and a chest strap HR is detected then begin HR control.
4. Press START key to start workout.
5. Press UP / DOWN key to adjust resistance level profile.
6. Press STOP key to pause workout. And again press the STOP key to stop the machine.

Built in Wireless Heart Rate Receiver

This machine is equipped with a built-in receiver for your heart rate monitoring. To get an accurate reading using these devices, you will need to be within 90cm of the console, and a minimum of 120cm from others using a heart rate monitoring device. (Note: The transmitter may fluctuate erratically if you are too close to other

Chest belt is not included into packing.

Troubleshooting

If you have a problem with your exercise equipment, before you do anything else please check that all the cables have been connected correctly. Loose cables are very common and many problems can be solved by making sure the cables are properly connected.

The following table details the most common problems and how to fix them. If you still have a problem after going through the troubleshooting guide please call your local YORK distributor for advice.

PROBLEM	CAUSE	CORRECTION
NO DISPLAY	No power	Keep pedaling, and make sure RPM is above 15
	Rechargeable battery is out of power or damaged.	Please use machine every three months at least to charge battery or change new battery
NO SPEED DISPLAY	Wires are damaged or not connected properly	Verify all wires are connected properly
	Speed sensor is too far from magnet	Contact your local YORK distributor
NO PULSE SIGNAL	Wires are damaged or not connected properly	Verify all wires are connected properly
	Too much hand movement	Grip firmly
	Palms too wet	Dry palms
	Hand Pulse Sensor is being gripped too tightly	Grip using moderate pressure
E1	EEPROM error message (MCU error)	

Notes



Fitness Guide

Starting and Finishing Your Workout

Begin and end each workout with a Warm Up / Down session - a few minutes of stretching to help prevent strains, pulls and cramps.

Correct Cross-training Form

To start using the cross trainer, simply stand on the foot pedals with the front of your shoes close to the front edge of the pedal cap. Place your hands at a comfortable position on the handlebars. Simply move your highest foot forward and follow the natural path of the machine.

Start on a load level that is comfortable to familiarize yourself with the machine. Once you are comfortable, start adjusting the load level to achieve the workout desired.

Forward and Reverse:

The cross trainer can be used in the forward and reverse direction to vary the muscles that you workout. This will also vary your workout helping you to stay motivated. To change directions, simply slow the pedals down until they stop and switch directions.

Load Level Adjustment:

The load level of cross trainer can be changed at any time during your workout. Adjusting your load level will allow you to increase or decrease your intensity level.

Suggested Stretches

The correct form for several basic stretches is shown at the right. Move slowly as you stretch—never bounce.

1. Hamstring Stretch

Sit with one leg extended. Bring the sole of the opposite foot toward you and rest it against the inner thigh of your extended leg. Reach toward your toes as far as possible. Hold for 15 counts, then relax. Repeat 3 times for each leg. Stretches: Hamstrings, lower back and groin.

2. Calf/Achilles Stretch

With one leg in front of the other, reach forward and place your hands against a wall. Keep your back leg straight and your back foot flat on the floor. Bend your front leg, lean forward and move your hips toward the wall. Hold for 15 counts, then relax. Repeat 3 times for each leg. To cause further stretching of the achilles tendons, bend your back leg as well. Stretches: Calves, achilles tendons and ankles.

3. Quadriceps Stretch

With one hand against a wall for balance, reach back and grasp one foot with your other hand. Bring your heel as close to your buttocks as possible. Hold for 15 counts, then relax. Repeat 3 times for each leg. Stretches: Quadriceps and hip muscles.

4. Inner Thigh Stretch

Sit with the soles of your feet together and your knees outward. Pull your feet toward your groin area as far as possible. Hold for 15 counts, then relax. Repeat 3 times. Stretches: Quadriceps and hip muscles.

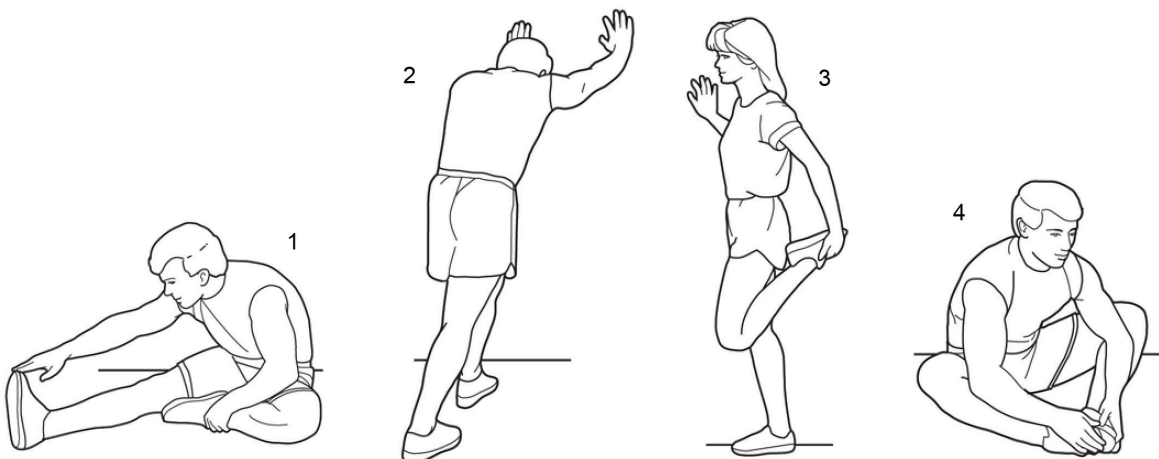

How Long Should I Exercise For?

That really depends on your current level of fitness. If you're just starting out on a new exercise program, you should start gradually and build up - do not try to do too much too quickly. 30 minutes, 3 times a week should be enough.

Don't push yourself too hard - you should never feel exhausted during or following exercise.

Heart Rate Training

To get the most out of your new piece of fitness equipment and see the best results from your training you should exercise at the right level of effort, and that means listening to your heart! Working out to a target heart rate means you can direct your workout to achieve different goals:

Good health - For those wishing to improve quality of life and general well being. Your sessions will need to be done at an intensity of between 50 - 60% of your estimated maximum heart rate, should last about 30 minutes and can be done on most days of the week.

Weight loss - To see a significant reduction in body fat, your sessions must be a little more intense - between 60 and 70% of your estimated maximum heart rate. These sessions can also be performed on most days of the week for up to 30 minutes.

Improving fitness levels - These sessions should be performed at 70 - 80% of your estimated maximum heart rate and can also involve bouts of interval training that would have your heart rate peaking for short times near your maximum heart rate level. These are intense sessions and will require at least a 48 hour rest between sessions.

Calculating Your Target Heart Rate

First, you need to find your estimated maximum heart rate using the formula "220 minus your age in years". So, if you are 35 years old your estimated maximum heart rate is:

$$220 - 35 = 185 \text{ beats per minute (bpm)}$$

Next, to calculate your target heart rate, simply multiply your estimated maximum heart rate (185bpm) by the applicable percentage. So, if your goal is better health:

$$185 \times 60\% = 111\text{bpm}$$

NOTE: The important issue to remember with all estimated calculations is that they are just estimates - if you don't feel comfortable exercising at your target then reduce it to a level you are comfortable with.

Heart rate training requires you to monitor your heart rate throughout the workout. For this we recommend using a chest strap (if your machine has a wireless receiver) or a heart rate monitor. For more information please get in touch using the Contact Us details.

Always consult your doctor before undertaking a new exercise regime. If you experience nausea, dizziness or other abnormal symptoms during exercise, stop at once and consult your doctor.

Exploded Drawing

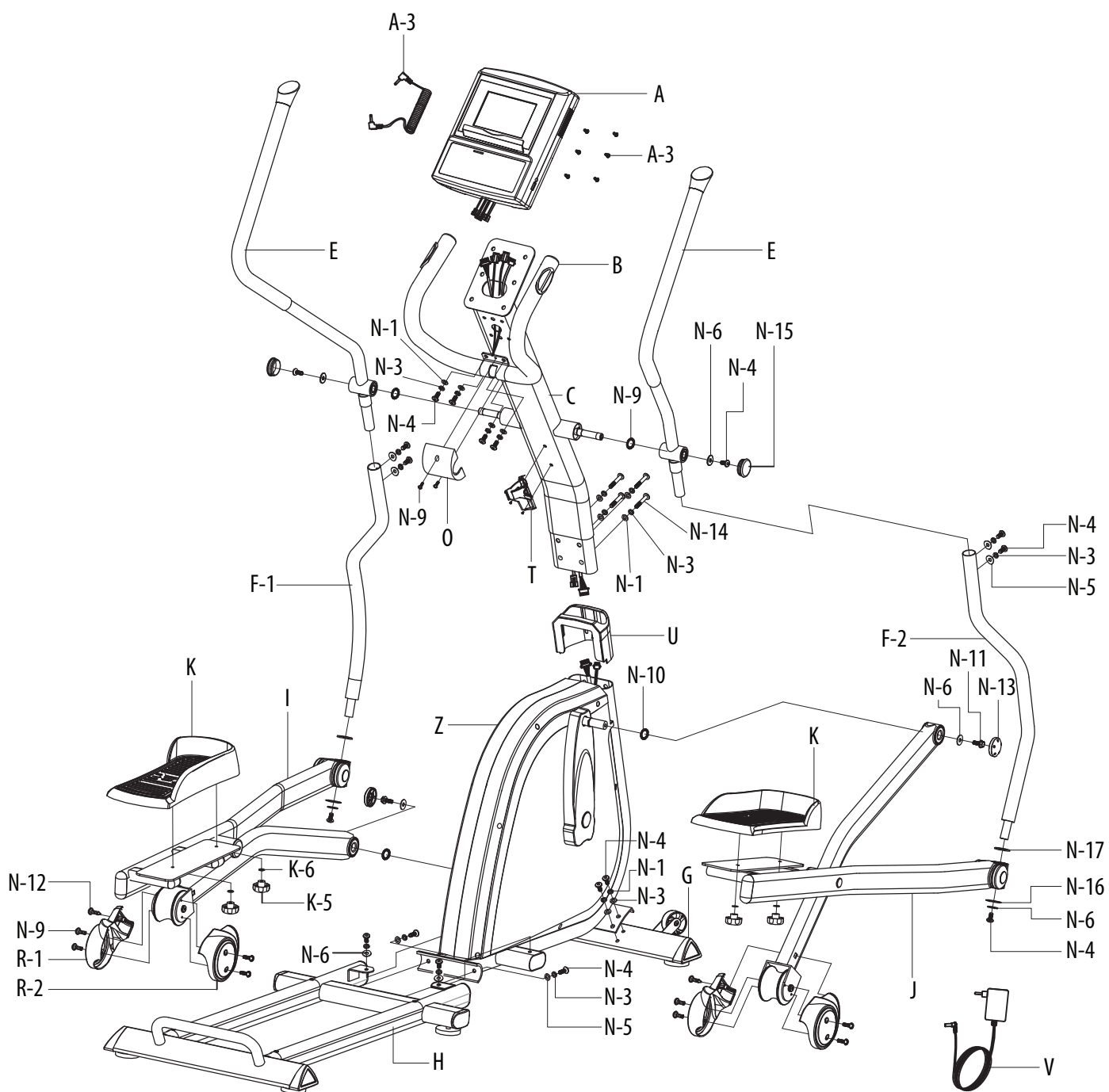

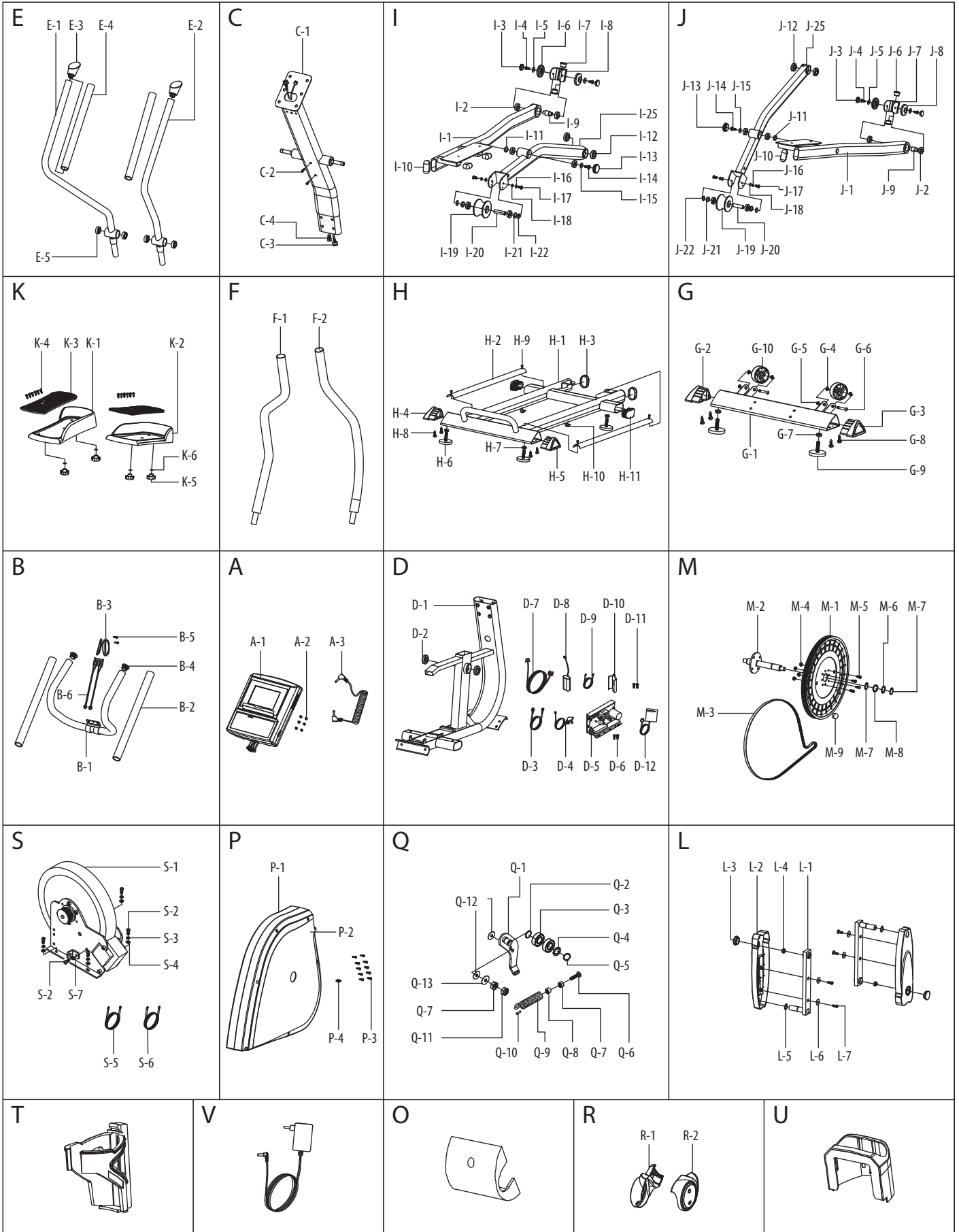

Part List

YORK REF.	REF.	DESCRIPTION	QTY.
52065-001	A	COMPUTER SET ()	1
52065-002	A-1	COMPUTER (AA00332)	1
52065-003	A-2	BOLT (M6*12L)	6
52065-004	A-3	VOICE CABLE (400L)	1
52065-005	B	FIXED HANDLEBAR SET ()	1
52065-006	B-1	FIXED HANDLEBAR ()	1
52065-007	B-2	FOAM (D30X3TX530L)	2
52065-008	B-3	HANDLE PUSLE (PE18)	2
52065-009	B-4	MUSHROOM CAP (D1 1/4"*29L)	2
52065-010	B-5	SCREW (ST4X25L)	2
52065-011	B-6	HANDLEPULSE CABLE (V)	2
52065-012	C	HANDLEBAR POST SET ()	1
52065-013	C-1	HANDLEBAR POST ()	1
52065-014	C-2	BOLT (M5*0.8*15L)	2
52065-015	C-3	UPPER COMPUTER CABLE (1000L)	1
52065-016	C-4	SENSOR COONNECTING CABLE (1000L)	1
52065-017	D	MAIN FRAME SET ()	1
52065-018	D-1	MAIN FRAME (JD-9115)	1
52065-019	D-2	BEARING (#6004Z2)	2
52065-020	D-3	LOWER COMPUTER CABLE (650L)	1
52065-021	D-4	SENSOR CABLE (300L)	1
52065-022	D-5	CONTROLLER (AE0009-V1.0)	1
52065-023	D-6	BOLT (M5*0.8*10L)	3
52065-024	D-7	ELECTRIC CABLE (700L)	1
52065-025	D-8	BATTERY ()	1
52065-026	D-9	BATTERY CONNECTING WIRE (650L)	1
52065-027	D-10	FIXING PLATE FOR THE BATTERY (97*37.4*1.5T)	1
52065-028	D-11	SCREW (ST4*1.41*12L)	2
52065-029	D-12	SENSOR (900L)	1
52065-030	E	HANDLEBAR SET ()	1
52065-031	E-1	LEFT HANDLE BAR ()	1
52065-032	E-2	RIGHT HANDLE BAR ()	1
52065-033	E-3	MUSHROOM CAP (95.8*50.8)	2
52065-034	E-4	FOAM (D30X3TX680L)	2
52065-035	E-5	BEARING (#6004Z2)	4
52065-036	F	SWING SUPPORT TUBE SET ()	1
52065-037	F-1	LEFT SWING SUPPORT TUBE ()	1
52065-038	F-2	RIGHT SWING SUPPORT TUBE ()	1
52065-039	G	STABILIZER SET ()	1
52065-040	G-1	FRONT STABILIZER ()	1
52065-041	G-2	LEFT TRIANGEL CAP (95.7*57.2*51.3)	1
52065-042	G-3	RIGHT TRIANGLE CAP (95.7*57.2*51.3)	1
52065-043	G-4	BUSHING (D16*D8.1*20)	4
52065-044	G-5	ANTI-LOOSE NUT (M8*1.25*8T)	2
52065-045	G-6	ALLEN BOLT (M8*1.25*60L)	2
52065-046	G-7	NUT (M10*1.5*8T)	2
52065-047	G-8	SCREW (ST4*1.41*15L)	4
52065-048	G-9	ADJUSTABLE WHEEL (D50*M10*1.5)	2
52065-049	G-10	ROUND WHEEL (D70.2*31)	2
52065-050	H	SLIDING BEAM SET ()	1
52065-051	H-1	SLIDING BEAM WELDING SET ()	1
52065-052	H-2	GUIDE PLATE FOR THE SLIDING BEAM (R19.1*681*1.5T)	2

YORK REF.	REF.	DESCRIPTION	QTY.
52065-053	H-3	CAP (40*60*11L)	2
52065-054	H-4	LEFT TRIANGEL CAP (95.7*57.2*51.3)	1
52065-055	H-5	RIGHT TRIANGLE CAP (95.7*57.2*51.3)	1
52065-056	H-6	ADJUSTABLE WHEEL (D50*M10*1.5)	4
52065-057	H-7	NUT (M10*1.5*8T)	4
52065-058	H-8	SCREW (ST4*1.41*15L)	4
52065-059	H-9	BOLT (M6*1*15L)	4
52065-060	H-10	BUFFER (R23X35X43)	2
52065-061	H-11	CAP (40*80*33)	2
52065-062	I	LEFT PEDAL SUPPORT SET ()	1
52065-063	I-1	LEFT PEDAL SUPPORT ()	1
52065-064	I-2	BEARING (#6003Z2)	6
52065-065	I-3	SIDE COVER (D29.1*13L)	4
52065-066	I-4	ALLEN BOLT (M8*1.25*20L)	2
52065-067	I-5	FLAT WASHER (D16*D8.5*1.2T)	2
52065-068	I-6	AXLE COVER (D60*13.5L)	2
52065-069	I-7	BUSHING (D19.15X(D25.6X32)XL(17+3))	2
52065-070	I-8	UNIVERSAL JOINT ()	1
52065-071	I-9	AXLE (D23*48L)	2
52065-072	I-10	CAP (30*70*10.5)	1
52065-073	I-11	CURVED WASHER (D22XD17X0.3T)	1
52065-074	I-12	BEARING (#6004Z2)	2
52065-075	I-13	ROUND CAP (D45*15)	1
52065-076	I-14	BOLT (M8X1.25X20)	1
52065-077	I-15	FLAT WASHER (D25XD8.5X2T)	1
52065-078	I-16	SPRING WASHER (D15.4*D8.2*2T)	2
52065-079	I-17	ALLEN BOLT (M8*1.25*20L)	2
52065-080	I-18	FLAT WASHER (D16*D8.5*1.2T)	2
52065-081	I-19	WHEEL (D87.2*55L)	1
52065-082	I-20	AXLE FOR THE WHEEL (D17*61.2L)	1
52065-083	I-21	CURVED WASHER (D22XD17X0.3T)	4
52065-084	I-22	C-RING (S-17(1T))	4
52065-085	I-25	LEFT PEDAL TUBE WELDING SET ()	1
52065-086	J	RIGHT PEDAL SUPPORT SET ()	1
52065-087	J-1	RIGHT PEDAL SUPPORT ()	1
52065-088	J-2	BEARING (#6003Z2)	6
52065-089	J-3	SIDE COVER (D29.1*13L)	4
52065-090	J-4	ALLEN BOLT (M8*1.25*20L)	2
52065-091	J-5	FLAT WASHER (D16*D8.5*1.2T)	2
52065-092	J-6	BUSHING (D19.15X(D25.6X32)XL(17+3))	2
52065-093	J-7	UNIVERSAL JOINT ()	1
52065-094	J-8	AXLE COVER (D60*13.5L)	2
52065-095	J-9	AXLE (D23*48L)	2
52065-096	J-10	CAP (30*70*10.5)	1
52065-097	J-11	CURVED WASHER (D22XD17X0.3T)	1
52065-098	J-12	BEARING (#6004Z2)	2
52065-099	J-13	ROUND CAP (D45*15)	1
52065-100	J-14	BOLT (M8X1.25X20)	1
52065-101	J-15	FLAT WASHER (D25XD8.5X2T)	1
52065-102	J-16	SPRING WASHER (D15.4*D8.2*2T)	2
52065-103	J-17	ALLEN BOLT (M8*1.25*20L)	2
52065-104	J-18	FLAT WASHER (D16*D8.5*1.2T)	2

YORK REF.	REF.	DESCRIPTION	QTY.
52065-105	J-19	WHEEL (D87.2*55L)	1
52065-106	J-20	AXLE FOR THE WHEEL (D17*61.2L)	1
52065-107	J-21	CURVED WASHER (D22XD17X0.3T)	4
52065-108	J-22	C-RING (S-17(1T))	4
52065-109	J-25	RIGHT PEDAL TUBE WELDING SET ()	1
52065-110	K	PEDAL SET ()	
52065-111	K-1	LEFT PEDAL (410.7*173.9*70)	1
52065-112	K-2	RIGHT PEDAL (410.7*173.9*70)	1
52065-113	K-3	PEDAL PAD (354.9*134.5*9)	2
52065-114	K-4	BOLT (ST4*1.41*12L)	12
52065-115	K-5	KNOB (D40*M6*12)	4
52065-116	K-6	FLAT WASHER (D14XD6.5X0.8T)	4
52065-117	L	CRANK SET ()	1
52065-118	L-1	CRANK WELDING SET ()	2
52065-119	L-2	CRANK COVER (339*102.6*29.9)	2
52065-120	L-3	SIDE COVER (D36X14)	2
52065-121	L-4	NUT (M10*1.25*7T)	2
52065-122	L-5	C-RING (D22.5*D18.5*1.2T)	2
52065-123	L-6	FLAT WASHER (D15*D5.2*1.0T)	4
52065-124	L-7	SCREW (ST4*1.41*15L)	4
52065-125	M	BELT WHEEL SET ()	1
52065-126	M-1	BELT WHEEL (D305X19.5)	1
52065-127	M-2	CRANK AXLE WELDING SET ()	1
52065-128	M-3	BELT (460 PJ6 (GATES))	1
52065-129	M-4	ANTI-LOOSE NUT (M6X1.0X6T)	4
52065-130	M-5	BOLT (M6X1.0X15L)	4
52065-131	M-6	FLAT WASHER (D26*D21*1.5T)	1
52065-132	M-7	C-RING (D22.5*D18.5*1.2T)	2
52065-133	M-8	CURVED WASHER (D27*D21*0.3T)	1
52065-134	M-9	ROUND MAGNET (M02)	1
52065-135	N	SCREW BAG SET ()	
52065-136	N-1	FLAT WASHER (D16*D8.5*1.2T)	12
52065-137	N-3	SPRING WASHER (D15.4 XD8.2X2T)	20
52065-138	N-4	ALLEN BOLT (M8X1.25X20L)	20
52065-139	N-5	CURVED WASHER (D22XD8.5X1.5T)	6
52065-140	N-6	FLAT WASHER (D25*D8.5*2T)	8
52065-141	N-9	SCREW (M5X0.8X12L)	10
52065-142	N-10	CURVED WASHER (D27*D21*0.3T)	4
52065-143	N-11	BOLT (M8*1.25*20L)	2
52065-144	N-12	SCREW (ST4*1.41*15L)	2
52065-145	N-13	AXLE COVER (D46*14.8)	2
52065-146	N-14	ALLEN BOLT (M8*1.25*50L)	4
52065-147	N-15	ROUND CAP (D50X15L)	2
52065-148	N-16	PLASTIC FLAT WASHER (D10*D24*0.4T)	2
52065-149	N-17	CURVED WASHER (D26*D19.5*0.3T)	2
52065-150	N-18	SPANNER (139*5T)	1
52065-151	N-19	ALLEN SPANNER (M6)	1
52065-152	O	PROTECTIVE COVE (100*81*40.8)	1
52065-153	P	CHAIN COVER SET ()	1
52065-154	P-1	LEFT CHAIN COVER (698.8*597*71.9)	1
52065-155	P-2	RIGHT CHAIN COVER (698.8*597*67.5)	1
52065-156	P-3	SCREW (ST4.2X1.4X20L)	10

YORK REF.	REF.	DESCRIPTION	QTY.
52065-157	P-4	PIN (D6*26.5*7.7)	1
52065-158	Q	FIXING PLATE FOR THE IDLE WHEEL SET ()	1
52065-159	Q-1	FIXING PLATE FOR THE IDLE WHEEL ()	1
52065-160	Q-2	FLAT WAHSER (D24*D16*1.5T)	1
52065-161	Q-3	BEARING (#99502)	2
52065-162	Q-4	CURVED WASHER (D21XD16.2X0.3T)	1
52065-163	Q-5	C-RING (S-16(1T))	1
52065-164	Q-6	ALLEN BOLT (M8*1.25*50L)	1
52065-165	Q-7	NUT (M8*1.25*6T)	2
52065-166	Q-8	FIXING NUT (D15*13L)	1
52065-167	Q-9	SPRING (D3*D19*67L)	1
52065-168	Q-10	PLASTIC CAP (D3*30L)	1
52065-169	Q-11	ANTI-LOOSE NUT (M8*1.25*8T)	1
52065-170	Q-12	PLASTIC FLAT WASHER (D10*D24*0.4T)	2
52065-171	Q-13	FLAT WASHER (D28*D8.5*3T)	1
52065-172	R	REAR AXLE COVER SET ()	
52065-173	R-1	LEFT REAR AXLE COVER (155*119.7*52.5)	2
52065-174	R-2	RIGHT REAR AXLE COVER (155*119.7*55.5)	2
52065-175	S	MAGNECT SYSTEM SET ()	1
52065-176	S-1	SELF-GENERATING ELECTRICAL SYSTEM (D242.7*76)	1
52065-177	S-2	SCREW (M6*1.0*15L)	5
52065-178	S-3	SPRING WASHER (D10.5*D6.1*1.3T)	4
52065-179	S-4	FLAT WASHER (D13*D6.5*1.0T)	5
52065-180	S-5	OUTER SYSTEM CABLE (500L)	1
52065-181	S-6	OUTER SYSTEM CABLE(II) (600L)	1
52065-182	S-7	FIXING PLATE (30*27*4T)	1
52065-183	T	WATER BOTTLE BRACKET (120*87*3T)	1
52065-184	U	UPPER PROTECTIVE COVER (137.1*121*73.4)	1
52065-185	V	ADAPTOR (OUTPUT 9V,3A)	1



YORK[®]
FITNESS

www.yorkfitness.com