

Get-U-Up™ Lift



DEALER: This manual **MUST** be given to the user of the patient lift.

USER: **BEFORE** using this patient lift, read this manual and save for future reference.

For more information regarding
Invacare products, parts, and services,
please visit www.invacare.com



Yes, you can.

WARNING

DO NOT USE THIS PRODUCT OR ANY AVAILABLE OPTIONAL EQUIPMENT WITHOUT FIRST COMPLETELY READING AND UNDERSTANDING THESE INSTRUCTIONS AND ANY ADDITIONAL INSTRUCTIONAL MATERIAL SUCH AS OWNER'S MANUALS, SERVICE MANUALS OR INSTRUCTION SHEETS SUPPLIED WITH THIS PRODUCT OR OPTIONAL EQUIPMENT. IF YOU ARE UNABLE TO UNDERSTAND THE WARNINGS, CAUTIONS OR INSTRUCTIONS, CONTACT A HEALTHCARE PROFESSIONAL, DEALER OR TECHNICAL PERSONNEL BEFORE ATTEMPTING TO USE THIS EQUIPMENT - OTHERWISE, INJURY OR DAMAGE MAY OCCUR.

ACCESSORIES WARNING

Invacare products are specifically designed and manufactured for use in conjunction with Invacare accessories. Accessories designed by other manufacturers have not been tested by Invacare and are not recommended for use with Invacare products.

SYMBOL LEGEND



"ATTENTION, see instructions for use".



"Date of Manufacture"

CAUTION - Pinch Points, fingers could be pinched.

WARNING - When positioning Lift, be aware of the position of the Swivel Bar and the patient. Injury could occur.



Device contains Lead Acid batteries. **DO NOT** dispose of batteries in normal household waste. They **MUST** be taken to a proper disposal site. Contact your local waste management company for information.

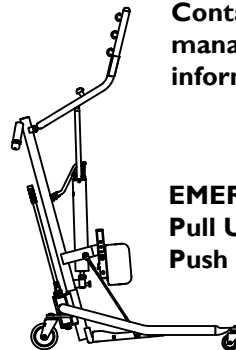

EMERGENCY Mechanical Lowering - Pull **UP** on **EMERGENCY Button**. Push **DOWN** on **Boom**.

NOTE: Updated versions of this manual are available on www.invacare.com.

TABLE OF CONTENTS

SPECIAL NOTES	5
LABEL LOCATIONS	6
TYPICAL PRODUCT PARAMETERS	7
SECTION 1—GENERAL GUIDELINES	8
Weight Limitation	8
Assembling the Lift.....	8
Using the Sling.....	8
Operating the Lift.....	9
Lifting the Patient	9
Transferring the Patient.....	9
Performing Maintenance.....	9
SECTION 2—ASSEMBLY.....	10
Attach the Mast to the Base Assembly	10
Attach the Horn to the Mast and Actuator.....	11
Check for proper hardware alignment	11
Attaching/Adjusting the Knee Pad.....	12
Attaching the Base Shifter Handle.....	12
SECTION 3—OPERATION	13
Introduction.....	13
Operating the Lift.....	14
Opening/Closing the Legs.....	14
Raising/Lowering Model Hydraulic Lifts	15
Adjusting Knee Pad Height	15
SECTION 4—LIFTING	16
Introduction.....	16
Lifting the Patient	17
Moving the Patient	18
SECTION 5—TRANSFERRING	19
Transferring to a Commode.....	20
Transferring to a Wheelchair	21
Transferring to a Bed	22
SECTION 6—USING LIFT AS A STANDING AID	23
Standing Procedure.....	23
SECTION 7—TROUBLESHOOTING	24

TABLE OF CONTENTS

SECTION 8—MAINTENANCE	25
Maintenance Safety Inspection Checklist.....	25
Hydraulic Pump.....	25
Lubricating the Lift	26
Detecting Wear and Damage.....	26
Cleaning the Sling and the Lift.....	26
Replacing the Knee Pad	26
LIMITED WARRANTY	27

SPECIAL NOTES

Signal words are used in this manual and apply to hazards or unsafe practices which could result in personal injury or property damage. Refer to the table below for definitions of the signal words.

SIGNAL WORD	MEANING
DANGER	Danger indicates an imminently hazardous situation which, if not avoided, will result in death or serious injury.
WARNING	Warning indicates a potentially hazardous situation which, if not avoided, could result in death or serious injury.
CAUTION	Caution indicates a potentially hazardous situation which, if not avoided, may result in property damage or minor injury or both.

NOTICE

THE INFORMATION CONTAINED IN THIS DOCUMENT IS SUBJECT TO CHANGE WITHOUT NOTICE.

Check ALL parts for shipping damage. If shipping damage is noted, DO NOT use. Contact dealer/carrier for further instruction.

MAINTENANCE

Maintenance MUST be performed ONLY by qualified personnel.

LABEL LOCATIONS

OPERATION OF THE PATIENT LIFT

The mast (C) includes the steering handles used to move and guide the lift. The mast is supported in a socket in the rear center of the base with casters (A). For transporting the lift in a vehicle, the mast, boom and pump assembly may be lifted from the base socket for convenient storage. Each time the mast is returned to the socket of the base, care should be used to push the mast as far as possible down into the socket. Rotate the mast slightly until it locks in the center position. The bottom of the mast tube is grooved on either side, and those grooves seat on tabs in the base socket to prevent any rotation of the mast during the lift procedure. Secure the mast to the base by securely tightening the screw located at the rear of the base.

Refer to the Patient Sling owner's manual for complete lifting preparation information.

The horn (D) is made with knobs on both sides and in the center to accept the sling that supports the patient during lift.

There are two controls on the pump assembly (F), which are the pump handle (G) and the control valve (H). With the control valve closed, the pump handle is moved up and down with slow strokes of even pressure to raise the horn. A patient in a sling attached to the horn would be elevated by this operation. The horn is lowered by opening the control valve and moving the control valve away from the pump handle. A safety gate is part of the hydraulic system that prevents sudden lowering of the horn regardless of how far the control valve is opened.

The knee pad (E) can be adjusted for patient support and comfort. Pull both adjustment pins outward at the same time to move the knee pad to the desired position. Make sure adjustment pins are engaged.

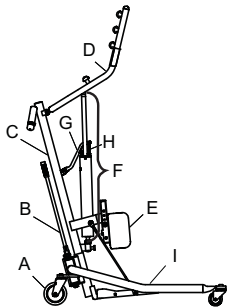

To raise the footplate (I), position the knee pad (E) in the highest setting. When the footplate is up, the knee pad can be adjusted to the desired position.

WARNING: For maximum stability and patient safety, operate this lift with the base legs in maximum open position and locked when lifting a patient.

The shifter handle (B) is used to open the legs of the base for stability before lifting a patient. The base legs should be locked in the maximum open position at all times when a patient is on the lift.

To open the base legs, grasp the shifter handle in one hand, and place the opposite hand on the steering handle of the mast for balance. Move the handle to your right to release the lock pin then bring the handle towards you in a complete half-circle. The lock pin should insert into a hole in the plate to lock the legs in full open position and the shifter handle should once again be vertical. To close the legs to a narrow position for storage, reverse the above procedure. If the shifter handle is not vertical (straight up and down), the lock pin is not seated in place.

Rev. A 1148135

WARNING



BEFORE using the Patient Lift, READ and UNDERSTAND the Owner's Manual for proper operation and safety procedures.

WARNING

WEIGHT LIMITATION 350 lbs. DO NOT roll casterbase over deep carpet, raised carpet bindings, door frames or any uneven surfaces that may cause the Patient Lift to tip over.

DO NOT lock the casters of the Patient Lift when lifting an individual. Casters MUST be left unlocked to allow Patient Lift to stabilize during lifting procedures.

USE ONLY INVACARE SLINGS and LIFT ACCESSORIES.

USE ONLY Get-U-Up™ Model Components for maintenance and replacement.

Refer to Owner's Manual for periodic maintenance procedures.

**Customer Service:
1-800-333-6900**

1148134 Rev. A

Serial Number

Serial Number

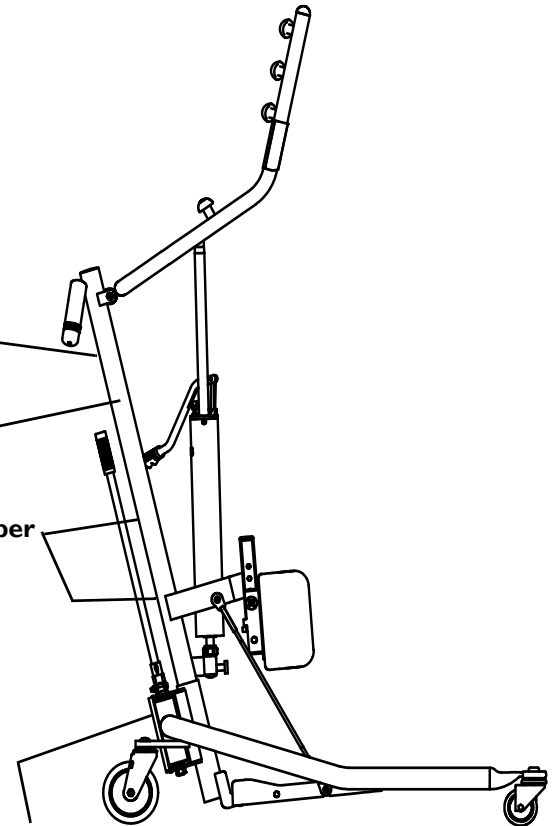

TYPICAL PRODUCT PARAMETERS

HEIGHT AT SLING HOOK-UP - MAX.	65.7 inches
HEIGHT AT SLING HOOK-UP - MIN.	36 inches
BASE WIDTH OPEN	37 inches
BASE WIDTH CLOSED	23 inches
BASE HEIGHT (CLEARANCE)	4.5 inches
BASE LENGTH	40.5 inches
OVERALL HEIGHT	45 inches
OVERALL LENGTH	44 inches
OVERALL WIDTH	23 inches
CASTER SIZE (REAR/FRONT)	5 inches / 3 inches
SLING OPTIONS	Standing or Transport
SLING MATERIAL	Polyester
STANDING SLING WIDTH LENGTH	36 inches 13 inches
TRANSPORT SLING WIDTH LENGTH	38.5 inches 36 inches
WEIGHT CAPACITY	350 lbs
WEIGHT IN CARTON	100 lbs
WEIGHT OUT OF CARTON	88 lbs

SECTION I—GENERAL GUIDELINES

⚠ WARNING

SECTION I - GENERAL GUIDELINES contains important information for the safe operation and use of this product.

Check all parts for shipping damage before using. In case of damage, DO NOT use the equipment. Contact the dealer for further instructions.

The Invacare patient lift is NOT a transport device. It is intended to transfer an individual from one resting surface to another (such as a bed to a wheelchair). Moving a person suspended in a sling over ANY distance is NOT recommended.

DO NOT attempt to transfer without the approval of the patient's physician, nurse or medical assistant. Thoroughly read the instructions in this Owner's Manual, observe a trained team of experts performing the lifting procedures and then perform the entire lift procedure several times with proper supervision and a capable individual acting as a patient.

Invacare Stand Assist and Transfer slings are specifically designed to be used in conjunction with Invacare patient lifts. Slings and accessories designed by other manufacturers are not to be utilized as a component of Invacare's patient lift system. Use the sling that is recommended by the individual's doctor, nurse or medical assistant for the comfort and safety of the individual that is being lifted.

Weight Limitation

DO NOT exceed the maximum weight limitation of the patient lift. The Get-U-Up lift has a weight limitation of 350 lbs.

Assembling the Lift

DO NOT overtighten the mounting hardware. This will damage the mounting brackets.

Using the Sling

Individuals that use the Stand Assist Sling MUST be able to support the majority of their own weight, otherwise injury may occur.

Stand Assist Slings: DO NOT use the stand assist sling in combination with the patient lift as a transport device. It is intended to transfer an individual from one resting surface to another (such as a bed to a wheelchair). Moving a person using the stand assist sling in combination with the patient lift over ANY distance is NOT recommended.

Stand Assist Slings: Individuals that use the stand assist sling MUST be able to support the majority of their own weight, otherwise injury can occur. Before lifting the patient, make sure the bottom edge of the stand support sling is positioned on the lower back of the patient and the patient's arms are outside the stand assist sling. The belt MUST be snug, but comfortable on the patient, otherwise the patient can slide out of the sling during transfer, possibly causing injury.

Transfer Slings: Before lifting the patient, make sure the bottom edge of the transfer sling is at the base of the spine and the patient's arms are outside the transport sling.

Transfer Slings: DO NOT raise the patient to a full standing position while using the transfer sling, otherwise injury may occur.

DO NOT use any kind of material (such as a plastic back incontinence pad or seating cushion) between the patient and sling material that may cause the patient to slide out of the sling during transferring.

After each laundering (in accordance with instructions on the sling), inspect sling(s) for wear, tears, and loose stitching.

Bleached, torn, cut, frayed, or broken slings are unsafe and could result in injury. Discard IMMEDIATELY.

DO NOT alter slings.

Be sure to check the sling attachments each time the sling is removed and replaced, to ensure that it is properly attached before the patient is removed from a stationary object (bed, chair or commode).

If the patient is in a wheelchair, secure the wheel locks in place to prevent the chair from moving forwards or backwards.

When connecting slings equipped with color coded straps to the patient lift, the shortest of the straps MUST be at the back of the patient for support. Using long section will leave little or no support for the patient's back. The loops of the sling are color coded and can be used to place the patient in various positions. The colors make it easy to connect both sides of the sling equally. Make sure that there is sufficient head support when lifting a patient.

Use an Invacare sling that is recommended by the individual's doctor, nurse or medical assistant for the comfort and safety of the individual being lifted.

Operating the Lift

Make sure there is an audible click when mounting battery on the battery charger to confirm proper mounting. Otherwise, injury or damage may occur.

Use the handles to push or pull the patient.

Lifting the Patient

Before positioning the legs of the stand up lift around the patient, make sure that the patient's feet are out of the way of the foot plate, otherwise injury may occur.

Adjustments for safety and comfort should be made before moving the patient. Patient's arms should be outside of the sling straps.

Before lifting a patient from a stationary object (wheelchair, commode or bed), slightly raise the patient off of the stationary object and check that all sling attachments are secure. If any attachment is not correct, lower the patient and correct the problem, then raise the patient and check again.

During transfer, with the patient suspended in a sling attached to the lift, DO NOT roll caster base over objects such as carpet, raised carpet bindings, door frames, or any uneven surfaces or obstacles that would create an imbalance of the patient lift to tip over. Use the steering handle on the mast at ALL times to push or pull the patient lift.

Invacare recommends locking the rear swivel casters ONLY when positioning or removing the sling (stand assist or transfer) from around the patient.

Transferring the Patient

Before transferring, check that the product's weight capacity can withstand the patient's weight.

Wheelchair wheel locks MUST be in a locked position before lowering the patient into the wheelchair for transport.

Performing Maintenance

Refer to [Maintenance](#) on page 25 for a maintenance schedule and procedures.

Regular maintenance of lifts and accessories is necessary to ensure proper operation.

After the first 12 months of operation, inspect all pivot points and fasteners for wear. If the metal is worn, the parts MUST be replaced. Make this inspection every six months thereafter.

DO NOT overtighten mounting hardware. This will damage mounting brackets.

Casters and axle bolts require inspections every six months to check for tightness and wear.

If using the lift in the area of a shower or bath, ensure the lift is wiped clean of any moisture after use. Do not store the lift in a damp area or in a damp condition. Periodically inspect all components for signs of corrosion and replace those that are corroded or damaged.

SECTION 2—ASSEMBLY

⚠ WARNING

Each time the mast is removed and assembled to the base assembly, the mast **MUST** be locked into the socket of the base assembly.

Attach the Mast to the Base Assembly

NOTE: For this procedure, refer to FIGURE 2.1.

1. Remove the locking screw from the base assembly.
2. Match the notch at the bottom of the mast with the tabs inside the socket of the base assembly.
3. Insert the mast into the socket and onto the tabs.
4. Try to turn the mast.

NOTE: If the mast turns in the socket, repeat STEPS 2 and 3 until proper alignment is obtained.

5. If the mast does not turn in the socket, insert the locking screw into the base and tighten securely.

Side view of the Base Assembly and Mast

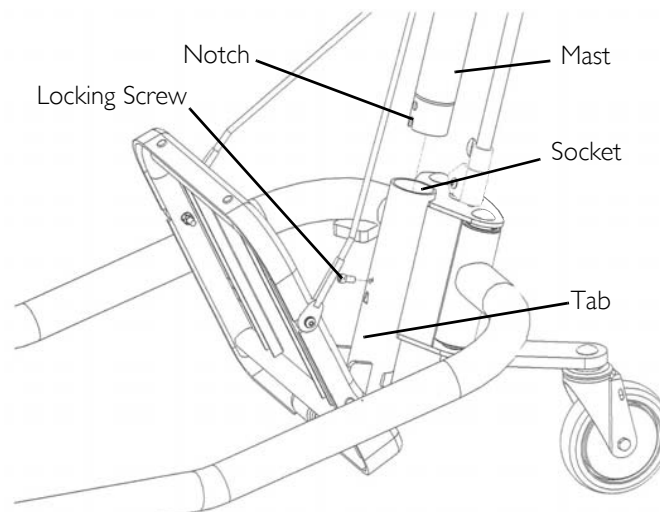

FIGURE 2.1 Attach the Mast to the Base Assembly

Attach the Horn to the Mast and Actuator

NOTE: For this procedure, refer to FIGURE 2.2.

1. Align the horn bushing with the holes in the horn mounting lugs on the mast.
2. Attach the horn to the mast with a shoulder bolt, two steel washers, two nylon washers and a locknut.

NOTE: The nylon washers MUST be installed between the horn bushing and horn mounting lugs.

3. Align the holes in the actuator cylinder rod with the holes in the cylinder mounting lugs on the horn.
4. Attach the actuator cylinder to the horn with a shoulder bolt and locknut.

Check for proper hardware alignment

CAUTION

The horn MUST pivot easily.

1. At the attachment point of the horn to the mast assembly, use an Allen wrench to hold the locknut and turn the shoulder bolt by hand (it should rotate without a lot of force being applied).
2. Raise the horn.
3. Push the control handle away from the pump assembly.
4. If the horn pivots easily, tighten the shoulder bolt and locknut.

NOTE: If the horn does not pivot easily or not at all, remove the locknut and shoulder bolt. Check all hardware for proper alignment. Reinstall hardware and repeat STEPS 1-4. If alignment problems continue, contact the Technical Support Department at Invoacare.

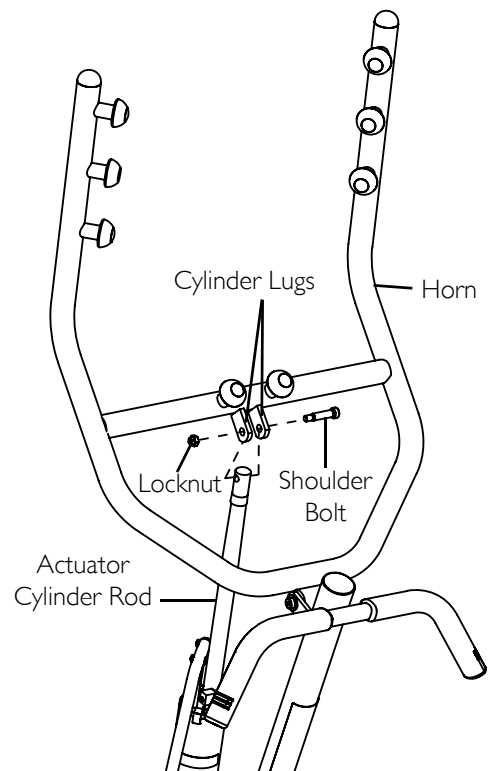
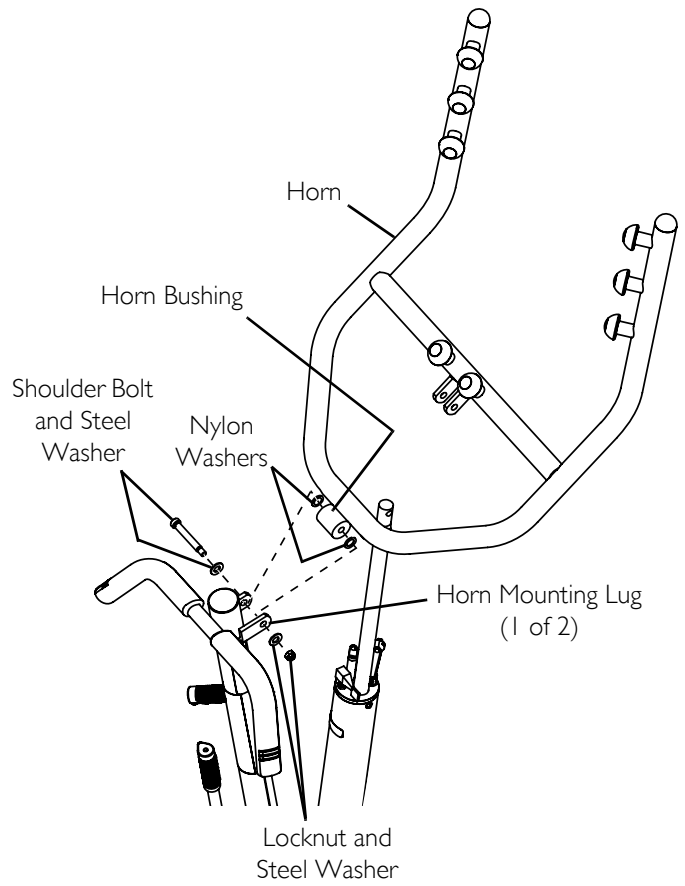

FIGURE 2.2 Attach the Horn to the Mast and Actuator

Attaching/Adjusting the Knee Pad

NOTE: For this procedure, refer to FIGURE 2.3.

⚠ WARNING

Never adjust knee pad while patient is in the standing position or while the lift is moving.

Always make sure that the adjustment pins are fully engaged in the height adjustment holes before use.

1. Pick a height setting that will be comfortable to the patient and provide the necessary support.

NOTE: The knee pad should be positioned so that the knee portion of the leg contacts the pad.

NOTE: The upper adjustment pins are typically used for shorter individuals. The lower adjustment pins are typically used for taller individuals.

2. Using both hands, pull both adjustment pins outward at the same time and hold.
3. Position the knee pad to the desired height and release adjustment pins into the corresponding alignment holes.
4. Check to make sure that both pins are engaged.

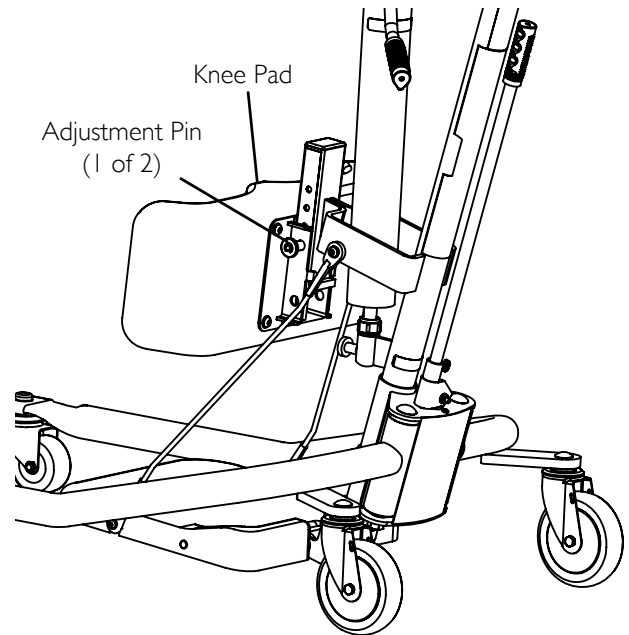

FIGURE 2.3 Attaching/Adjusting the Knee Pad

Attaching the Base Shifter Handle

NOTE: For this procedure, refer to FIGURE 2.4.

1. Insert the base shifter handle into the cam lock assembly at the back of the base.
2. Align the holes of the shifter handle and cam lock assembly.
3. Tighten the thumbscrew to secure the shifter handle in place.

NOTE: This should prevent the base shifter handle from being removed.

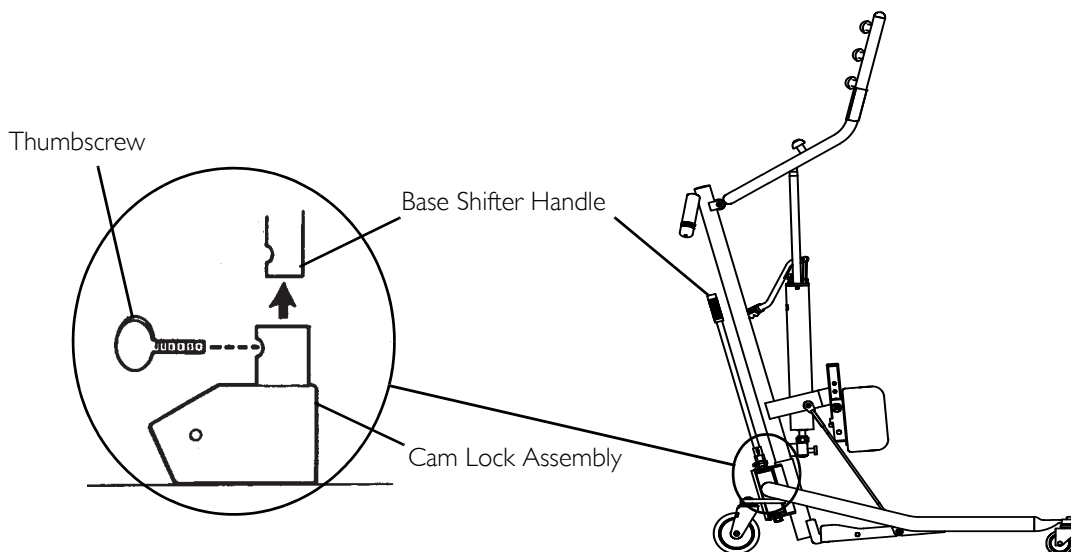

FIGURE 2.4 Attaching the Base Shifter Handle

SECTION 3—OPERATION

Introduction

⚠ WARNING

DO NOT attempt any transfer of a patient without approval of the patient's physician, nurse, or medical assistant. Thoroughly read the instructions in this owner's manual, observe a trained team of experts performing the lifting procedures and then perform the entire lift procedure several times with proper supervision and a capable individual acting as a patient.

ONLY operate the lift with the legs of the lift in the maximum open position for optimum stability and safety. If the patient is in a sling and it becomes necessary to move through a narrow passage, close the legs of the stand up lift only as long as it takes to move through the passage. When the stand up lift is through the passage, return the legs to the maximum open position.

If it is necessary to close the legs to maneuver the stand up lift under a bed, close the legs only as long as it takes to position the stand up lift over the patient and lift the patient off the surface of the bed. When the legs of the stand up lift are no longer under the bed, return the legs to the maximum open position.

Invacare slings and lift accessories are specifically designed to be used in conjunction with Invacare lifts. Slings and accessories designed by other manufacturers are not to be utilized as a component of Invacare's lift system.

DO NOT exceed maximum weight limitation of the lift. The weight limitation for the **Get-U-Up Lift** is 350 lbs.

ALWAYS keep hands, fingers, feet and toes clear of moving parts to avoid injury.

NOTE: Invacare recommends that two assistants be used for all lifting preparation and transferring to/from procedures; however, the stand up lift can be operated with one assistant. The use of one assistant is based on the evaluation of the health care professional for each individual case.

Operating the Lift

NOTE: For this procedure, refer to FIGURE 3.1.

Opening the Legs

1. Stand at the rear of the lift and grasp the shifter handle in one-hand and place the opposite hand on the steering handle of the mast for balance. Refer to Details "A" and "B".
2. Push the shifter handle to your right to release the lock pin from its mounting hole.
3. Turn the handle clockwise until you are able to secure the lock pin into the opposite mounting hole to fully open the legs of the base. Refer to Detail "C".

NOTE: The lock pin **MUST** insert into its mounting hole in the socket assembly to lock the legs in the full open position. The shifter handle will be in the vertical position and parallel with the mast assembly.

⚠ WARNING

If the shifter handle is NOT vertical, the lock pin is NOT seated in the socket assembly. DO NOT use the lift until the lock pin is properly seated and locked in place or injury and/or damage may occur.

Closing the Legs

1. Stand at the rear of the lift and grasp the shifter handle in one-hand.
2. Place the opposite hand on the steering handle of the mast for balance. Refer to Details "A" and "B".
3. Push the shifter handle to your right to release the lock pin from its mounting hole.
4. Turn the handle counter-clockwise until you are able to secure the lock pin into the opposite mounting hole to close the legs of the base. Refer to Detail "C".

DETAIL "A"

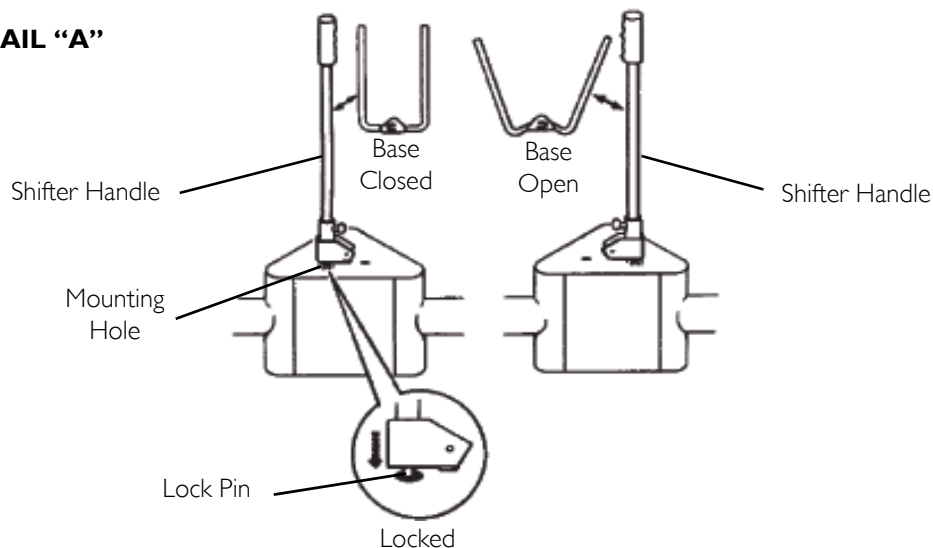

DETAIL "B"

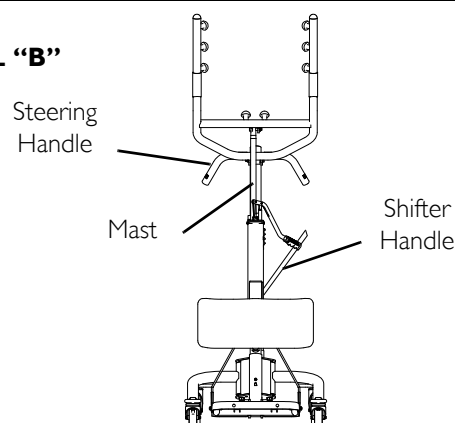

DETAIL "C"

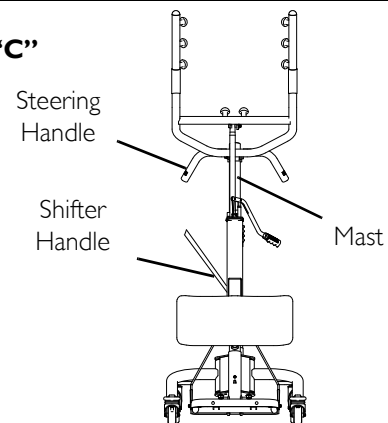

FIGURE 3.1 Opening/Closing the Legs

Raising/Lowering the Hydraulic Lift

NOTE: For this procedure, refer to FIGURE 3.2.

Raising the Lift

NOTE: Ensure the control valve is in the closed position (control valve positioned towards pump handle).

1. Move the pump handle up and down to raise the lift.

Lowering the Lift

NOTE: Ensure the control valve is in the open position (control valve positioned away from pump handle).

NOTE: The weight of the person on the lifting arm causes the lift arm to lower when the control valve is open.

NOTE: The rate of descent is controlled by varying the amount that the control valve is opened. A safety gate is part of the hydraulic system that maintains a SLOW constant descent of the boom regardless of how far the control valve is opened.

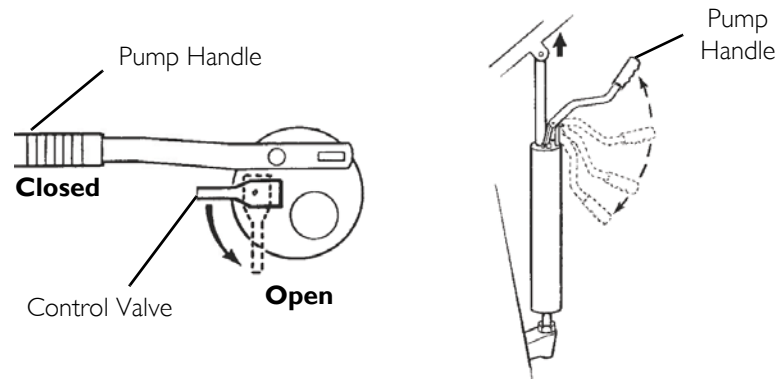

FIGURE 3.2 Raising/Lowering the Hydraulic Lift

SECTION 4—LIFTING

Introduction

⚠ WARNING

DO NOT attempt any transfer without approval of the patient's physician, nurse or medical assistant.

Invacare patient slings are made specifically for use with Invacare patient lifts. For the safety of the patient, DO NOT intermix patient slings and patient lifts of different manufacturers.

NOTE: Invacare recommends that two assistants be used for all lifting preparation and transferring to/from procedures; however, our equipment will permit proper operation by one assistant. The use of one assistant is based on the evaluation of the health care professional for each individual case.

NOTE: Refer to the patient sling owner's manual, P/N 1023891, for more information.

Positioning the Stand Up Lift

NOTE: Before positioning the legs of the patient lift under a bed, make sure that the area is clear of any obstructions.

⚠ WARNING

The legs of the stand up lift **MUST** be in the maximum open position for optimum stability and safety. If it is necessary to close the legs to maneuver the stand up lift under a bed, close the legs only as long as it takes to position the stand up lift over the patient and lift the patient off the surface of the bed. When the legs of the lift are no longer under the bed, return the legs to the maximum open position.

Before positioning the legs of the stand up lift near the patient, make sure the patient's feet are out of the way of the footplate, otherwise injury can occur.

1. Stand at the rear of the lift and grasp the shifter handle in one-hand and place the opposite hand on the steering handle of the mast for balance.
2. Push the shifter handle to your right to release the lock pin from its mounting hole.
3. Turn the handle clockwise until you are able to secure the lock pin into the opposite mounting hole to fully open the legs of the base.

NOTE: The lock pin MUST insert into its mounting hole in the socket assembly to lock the legs in the full open position. The shifter handle will be in the vertical position and parallel with the mast assembly.

⚠ WARNING

If the shifter handle is NOT vertical, the lock pin is NOT seated in the socket assembly. DO NOT use the lift until the lock pin is properly seated and locked in place or injury and/or damage may occur.

4. Position the stand up lift using the mast handle.
5. Lower the lift arms for easy attachment of the patient sling.

Lifting the Patient

⚠ WARNING

DO NOT exceed the maximum weight limitation of 350 lbs.

DO NOT use slings and stand up lifts of different manufacturers. Invacare slings are made specifically for use with Invacare stand up lifts. Injury or damage may occur.

DO NOT move the patient if the sling is not properly connected to the attachment points of the stand up lift. Check that the sling is properly connected to the attachment points prior to lifting a patient. If any attachments are not properly in place, correct the problem. When the sling is elevated a few inches off the stationary surface and before moving the patient, check again to make sure that all sling attachments are secure. If any attachments are not properly in place, lower the patient back onto the stationary surface and correct this problem - otherwise, injury or damage may occur.

Adjustments for safety and comfort should be made before moving the patient. Patient's arms should be outside of the straps.

Individuals that use the stand assist sling **MUST** be able to support the majority of their own weight, otherwise injury can occur.

Stand Assist Slings - Before lifting the patient, make sure the bottom edge of the Stand Assist Sling is positioned on the lower back of the patient and the patient's arms are outside the standing sling.

Transfer Slings - Before lifting the patient, make sure the bottom edge of the Transfer Sling is at the base of the spine and the patient's arms are outside the sling. **DO NOT** raise the patient to a full standing position.

Before lifting the patient, the belt **MUST** be snug but comfortable on the patient, otherwise the patient can slide out of the sling during transfer, possibly causing injury.

NOTE: For this procedure, refer to FIGURE 4.1 on page 18.

1. Instruct patient to hold onto the handgrips on both sides of the stand up lift. Refer to Detail "A".
2. Instruct the patient to lean back into the stand assist or transport sling.
3. Ensure the following:
 - Patient's knees are secure against the knee pad.
 - Patient's feet are positioned on the footplate.
 - The bottom edge of either the standing sling is positioned on the lower back or the transport sling is at the base of the patient's spine.
 - The patient's arms are outside of the standing or transport sling.
 - The legs are in the maximum open position.

⚠ WARNING

Before transferring, check that the wheelchair weight capacity can withstand the patient's weight. Refer to Typical Product Parameters in the wheelchair owner's manual.

If transferring from a wheelchair, the wheelchair wheel locks **MUST** be in the locked position before lowering the patient into the wheelchair. Otherwise, injury may occur.

4. If transferring from a wheelchair, lock the wheel locks on the wheelchair. Refer to Detail "B".
5. Raise the patient above the surface (bed, wheelchair, or commode) high enough to clear the surface. The patient's weight will be fully supported by the lift. Refer to Detail "C" on page 18 and Operating the Lift on page 14.

SECTION 4—LIFTING

NOTE: The lower center of gravity provides stability making the patient feel more secure and the lift easier to move.

NOTE: The lift arms will stay in position until lowered.

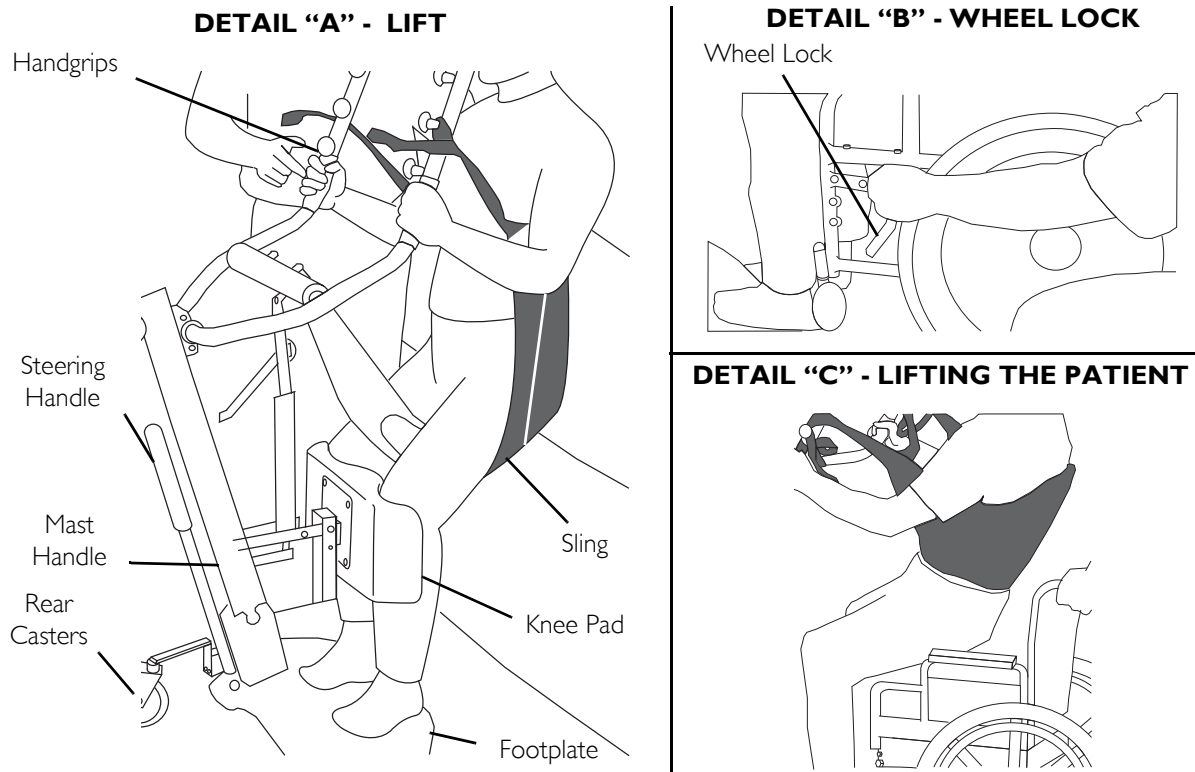

FIGURE 4.1 Lifting the Patient

Moving the Patient

⚠ WARNING

DO NOT move a person suspended in a sling any distance. The Invacare lift is **NOT** a transport device. It is intended to transfer a seated individual from one resting surface to another (such as a bed to a wheelchair). **Otherwise, injury or damage may occur.**

The legs of the stand up lift **MUST** be in the maximum open position for optimum stability and safety. If the patient is in a sling and it becomes necessary to move through a narrow passage, close the legs of the stand up lift only as long as it takes to move through the passage. **When the stand up lift is through the passage, return the legs to the maximum open position.**

DO NOT roll caster base over objects such as carpet, raised carpet bindings, door frames, or any uneven surfaces or obstacles that would create an imbalance of the lift during transfer of a patient suspended in the lift sling. **This could cause the lift to tip over. Use the mast handle at all times to push or pull the lift.**

NOTE: For this procedure, refer to Detail "C" of FIGURE 4.1.

1. Ensure the legs of the stand up lift are in the maximum open position. If not, open legs to the maximum open position.
2. Move the stand up lift away from the surface using the steering handle.
3. Slowly move the patient to the desired surface.

SECTION 5—TRANSFERRING

Introduction

⚠ WARNING

DO NOT attempt any transfer of a patient without approval of the patient's physician, nurse, or medical assistant.

DO NOT move the patient if the sling is not properly connected to the attachment points of the stand up lift. Check that the sling is properly connected to the attachment points prior to lifting a patient. If any attachments are not properly in place, correct the problem. When the sling is elevated a few inches off the stationary surface and before moving the patient, check again to make sure that all sling attachments are secure. If any attachments are not properly in place, lower the patient back onto the stationary surface and correct this problem - otherwise, injury or damage may occur.

Adjustments for safety and comfort should be made before moving the patient. The patient's arms should be outside the straps.

Before positioning the legs of the stand up lift around the patient, make sure the patient's feet are out of the way of the footplate, otherwise injury can occur.

DO NOT use slings and stand up lifts of different manufacturers. Invacare slings are made specifically for use with Invacare stand up lifts. Otherwise, injury or damage may occur.

The legs of the stand up lift **MUST** be in the maximum open position before lifting the patient for optimum stability and safety. If the patient is in a sling and it becomes necessary to move through a narrow passage, close the legs of the stand up lift only as long as it takes to move through the passage. When the stand up lift is through the passage, return the legs to the maximum open position. If it is necessary to close the legs to maneuver the stand up lift under a bed, close the legs only as long as it takes to position the stand up lift over the patient and lift the patient off the surface of the bed. When the legs of the stand up lift are no longer under the bed, return the legs to the maximum open position.

DO NOT roll caster base over objects such as carpet, raised carpet bindings, door frames, or any uneven surfaces or obstacles that would create an imbalance of the lift during transfer of a patient suspended in the lift sling. This could cause the lift to tip over. Use the mast handle at all times to push or pull the lift.

Be sure to check the sling attachments each time the sling is removed and replaced to ensure that it is properly attached before the patient is removed from a surface.

NOTE: Invacare recommends that two assistants be used for all lifting preparation and transferring to/from procedures; however, our equipment will permit proper operation by one assistant. The use of one assistant is based on the evaluation of the health care professional for each individual case.

Transferring to a Commode

NOTE: For this procedure, refer to FIGURE 5.1.

1. Raise the patient high enough to clear the arms of the commode chair. Their weight will be supported by the lift. Refer to Detail “A”.
2. Guide the patient onto the commode chair.
3. Lower the patient onto the commode chair.
4. Perform one of the following (refer to Detail “B” or “C”):
 - Standing Sling - unhook the standing sling from the attachment points on the lift.
 - Transport Sling -
 - i. Unhook the transport sling from the bottom attachment points on the lift.
 - ii. Lift up on the patient’s legs and remove the thigh supports from underneath the patient.
 - iii. If desired, unhook the transport sling from the top attachment points on the lift.

NOTE: The patient can remain in the upper portion of the transport sling while using the commode.

5. Instruct or assist the patient in lifting their feet off the footplate.
6. Remove the sling from around the patient.
7. Pull the lift away from the commode.
8. When complete, recheck the sling for correct attachments.
9. To lift the patient from the commode, refer to [Lifting](#) starting on page 16.

DETAIL “A” - POSITIONING PATIENT



DETAIL “B” - UNHOOKING SLING

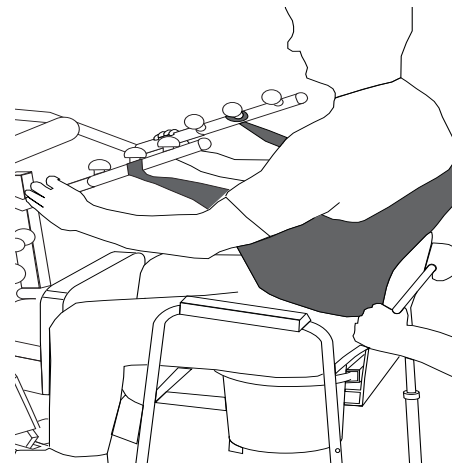

DETAIL “C” - UNHOOKING SLING AND STRAPS

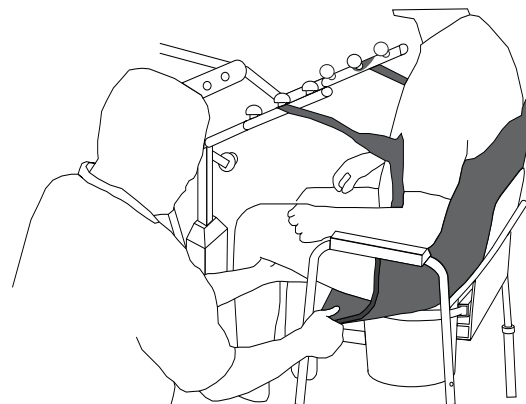

FIGURE 5.1 Transferring to a Commode

Transferring to a Wheelchair

NOTE: For this procedure, refer to FIGURE 5.2.

NOTE: Before transferring, check that the wheelchair weight capacity can withstand the patient's weight. Refer to Typical Product Parameters in the wheelchair owner's manual

1. Ensure the legs of the lift with the patient in the sling are in the open position.
2. Move the wheelchair into position. Refer to Detail "A".
3. Engage the rear wheel locks of the wheelchair to prevent movement of the wheelchair. Refer to Detail "B".

⚠ WARNING

DO NOT place the patient in the wheelchair if the locks are not engaged. The wheelchair wheel locks **MUST** be in a locked position before lowering the patient into the wheelchair for transport. Otherwise, injury may result.

4. Position the patient over the wheelchair.
5. Lower the patient into the wheelchair. Refer to Detail "C".
6. Unhook the sling from all attachment points on the lift. Refer to Detail "D".
7. Instruct patient to lift their feet off the footplate. Assist the patient if necessary.
8. Remove the sling from around the patient.
9. Pull the lift away from the wheelchair.

DETAIL "A" - UNHOOKING SLING AND STRAPS

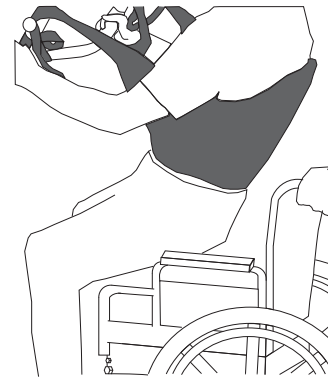

DETAIL "B" - LOCKING THE WHEELCHAIR

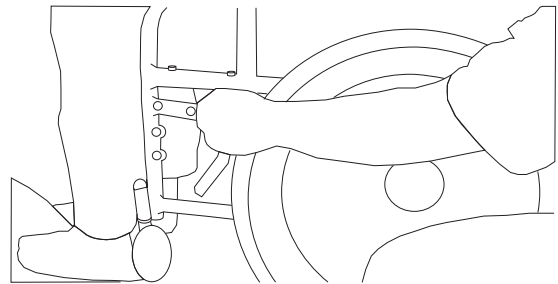

DETAIL "C" - LOWERING

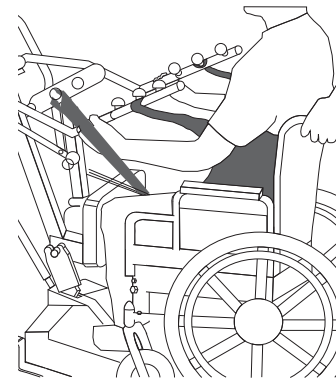

DETAIL "D" - UNHOOKING SLING

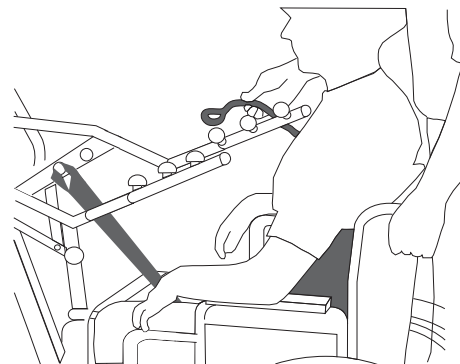

FIGURE 5.2 Transferring to a Wheelchair

Transferring to a Bed

NOTE: For this procedure, refer to FIGURE 5.3.

NOTE: The lower center of gravity provides stability making the patient feel more secure and the lift easier to move.

NOTE: The lift arms will stay in position until lowered.

1. Position the patient as far over the bed as possible.

NOTE: If patient is being transferred from a surface that is lower than the bed, raise the patient above the surface of the bed. The patient should be elevated just high enough to clear the bed with their weight fully supported by the lift.

2. Lower the patient onto the bed.
3. Unhook the sling from all attachment points on the lift.
4. Instruct the patient to lift their feet off of the footplate. Assist the patient if necessary.
5. Remove the standing or transport sling from around the patient.
6. Pull the lift away from the bed.

DETAIL "A" - LOWERING

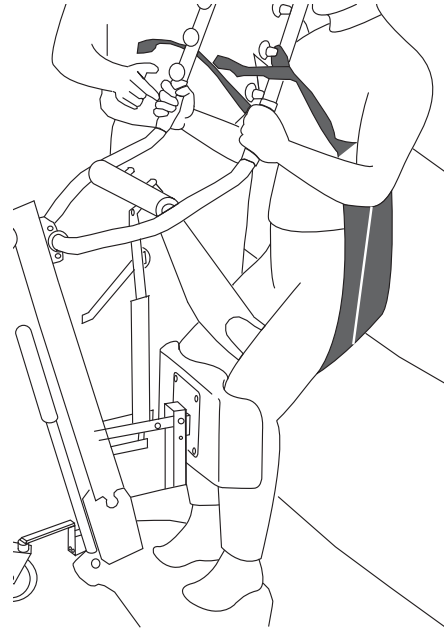

DETAIL "B" - UNHOOKING THE SLING

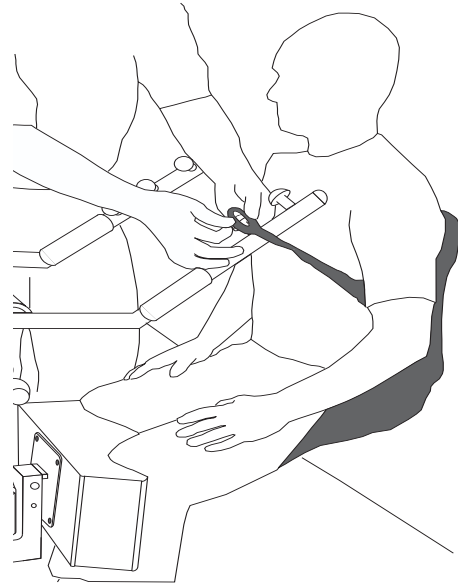

FIGURE 5.3 Transferring to a Bed

SECTION 6—USING THE PATIENT LIFT AS A STANDING AID

NOTE: For this procedure, refer to FIGURE 6.1.

NOTE: The Get-U-Up lift can be used as an aid to lift a person from a seated to a standing position. A minimum of two caregivers is required for this procedure.

NOTE: Invacare recommends that two assistants be used for all lifting preparation and transferring to/from procedures; however, our equipment will permit proper operation by one assistant. The use of one assistant is based on the evaluation of the health care professional for each individual case.

Standing Procedure

1. Ensure that the patient is capable of walking.
2. Fold the footplate toward the mast.
3. Use the adjustment pins to move the kneepad to a comfortable position.
4. Ensure that the patient is in a sitting position to begin the procedure.
 - A. If the patient is in bed and requires assistance to come to a sitting position, raise the back of the bed.
 - B. Place the lift over the bed with the lift arms angled toward the patient.
 - C. Instruct the patient to grasp the lift arms.
 - D. As the lift arms are raised, the patient should move legs to the side of the bed until a sitting position on the side of the bed is assumed.
- NOTE: The caregivers should assist as needed.
- E. Pull the lift away as needed to accommodate the patient's feet and legs over the side of the bed.
5. With one caregiver on each side of the patient, place a gait belt on the patient.
6. Ensure that the patient is wearing shoes with skid-proof soles.
7. If the patient is on the bed, raise the bed (if possible) while ensuring that the patient's feet remain on the floor.
8. If a walker is to be used, place the walker in front of the patient.
9. Advance the lift toward the patient so that the patient can easily reach the lift arms.
10. Instruct the patient to grasp the lift arms.
11. Ensure that the patient's feet are directly under them.
12. Begin raising the lift arms.
13. On a count of three, instruct the patient to pull and stand-up while the caregivers support with the gait belt.

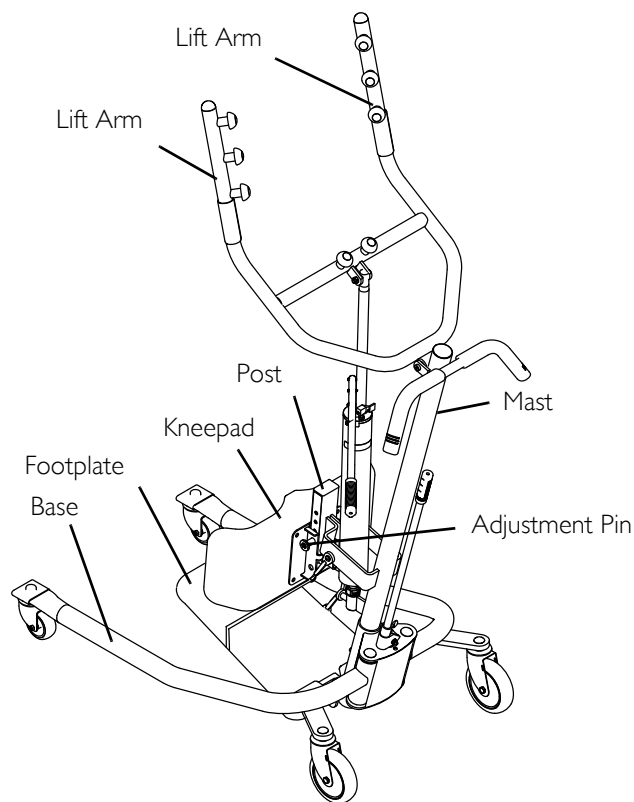

Note: The upper adjustment pins are typically used for shorter individuals. The lower adjustment pins are typically used for taller individuals.

FIGURE 6.1 Standing Procedure

⚠ WARNING

DO NOT lift the patient.

14. Remove the lift to allow the patient to walk.

SECTION 7—TROUBLESHOOTING

SYMPTOMS	FAULTS	SOLUTION
Stand up lift feels loose.	Mast/base joint loose. Tie-rods are loose.	Tighten the bolt, washer and locknut that secure the mast to the base. Refer to Assembling the Patient Lift on page 10.
Casters/brakes noisy or stiff.	Fluff or debris in bearings.	Refer to Hydraulic Pump on page 25.
Noisy or dry sound from pivots.	Needs lubrication.	Refer to Hydraulic Pump on page 25.
Lift arms will not lower in uppermost position.	Lift arms require a minimum weight load to lower from the uppermost position.	Pull down slightly on the lift arms.

NOTE: If problems are not remedied by the suggested means, please contact your dealer or Invacare.

SECTION 8—MAINTENANCE

- When used for in-home use, a full maintenance safety inspection is required prior to each new user.
- If using the lift in the area of a shower or bath, ensure the lift is wiped clean of any moisture after use. Do not store the lift in a damp area or in a damp condition. Periodically inspect all components for signs of corrosion and replace those that are corroded or damaged.
- The lift is designed to provide a maximum of safe, efficient and satisfactory service with minimum care and maintenance. If you question the safety of any part of the lift, contact your dealer immediately and advise them of the problem.
- There is no adjustment or maintenance of the casters, other than cleaning, lubrication and checking axle and swivel bolts for tightness. Remove all debris, etc. from the caster and swivel bearings. If any parts are worn, replace these parts IMMEDIATELY.
- Regular cleaning will reveal loose or worn parts, enhance smooth operation and extend the life expectancy of the lift.

Maintenance Safety Inspection Checklist

ITEM	INITIALLY	INSTITUTIONAL INSPECT/ADJUST MONTHLY	IN-HOME INSPECT/ADJUST PERIODICALLY
THE CASTER BASE			
Inspect for missing hardware.	X	X	X
Base opens/closes with ease.	X	X	X
Inspect casters and axle bolts for tightness.	X	X	X
Inspect casters for smooth swivel and roll.	X	X	X
Inspect and clear casters of debris.	X	X	X
Inspect roll pin to ensure secure to base.	X	X	X
THE MAST			
Mast MUST be securely assembled to lift arms.	X	X	X
Inspect for bends or deflections.	X	X	X
Inspect pivot joints for wear.	X	X	X
THE LIFT ARMS AND LINKAGE			
Check all hardware and attachment points.	X	X	X
Inspect for bends or deflections.	X	X	X
Inspect bolted joints of lift arms for wear.	X	X	X
Inspect to ensure that the lift arms are centered between the base legs.	X	X	X
Ensure that the bolt is tightly secured.	X	X	X
Inspect pivot joints for wear.	X	X	X
SHIFTER HANDLE			
Operates smoothly.	X	X	X
Locks adjustable base whenever engaged.	X	X	X
Check roll pin for wear	X	X	X
CLEANING			
Whenever necessary.	X	X	X
SLINGS AND HARDWARE			
Check all sling attachments for wear.	X	X	X
Inspect sling material for wear.	X	X	X
Inspect straps for wear.	X	X	X
Check that all labels are present and legible.	X	X	X

Hydraulic Pump

All parts of the hydraulic pump are precision machined then carefully assembled and tested to ensure reliable service. The pump assembly is completely enclosed and sealed with Neoprene rings to prevent leakage of hydraulic oil. A small amount of oil (about a drop) will accumulate around the piston from time to time and should be removed with a facial tissue.

WARNING

The hydraulic pump is sealed at the factory and if service is required, the pump unit **MUST** be returned to the factory for repair. **DO NOT** attempt to open the hydraulic pump or obtain local service. This will void the warranty and might result in damage and costly repair. Consult your dealer or contact Invacare for information.

Lubricating the Lift

A six month check and lubrication should ensure continued safety and reliability of the patient lift.

The casters **MUST** swivel and roll smoothly. A light grease (waterproof auto lubricant) may be applied to the ball bearing swivel of the casters once a year. Apply more frequently if the casters are exposed to extreme moist conditions.

Lubricate all pivot points. Wipe all excess lubricant from lift surface.

The connection between the mast and the base should be cleaned and coated with petroleum jelly prior to assembly.

Detecting Wear and Damage

It is important to inspect all stressed parts, such as slings, sling attachment knobs, and any pivot for slings for signs of cracking, fraying, deformation or deterioration. Replace any defective parts immediately and ensure that the lift is not used until repairs are made.

All sling metal parts should be inspected every three months and if wear is apparent, replacement must be made.

Check that all labels are present and legible. Replace if necessary.

Cleaning the Sling and the Lift

The sling should be washed regularly in water temperature of 180°F (82°C) and a biological solution. A soft cloth, dampened with water and a small amount of mild detergent, is all that is needed to clean the lift. The lift can be cleaned with non-abrasive cleaners.

Replacing the Knee Pad

NOTE: For this procedure, refer to FIGURE 8.1.

1. Remove the four button screws and washers that secure existing knee pad to the lift.
2. Remove the existing knee pad from the lift.
3. Position the mounting holes in the new knee pad with the mounting holes in the lift.
4. Using the existing hardware, secure the new knee pad to the lift.

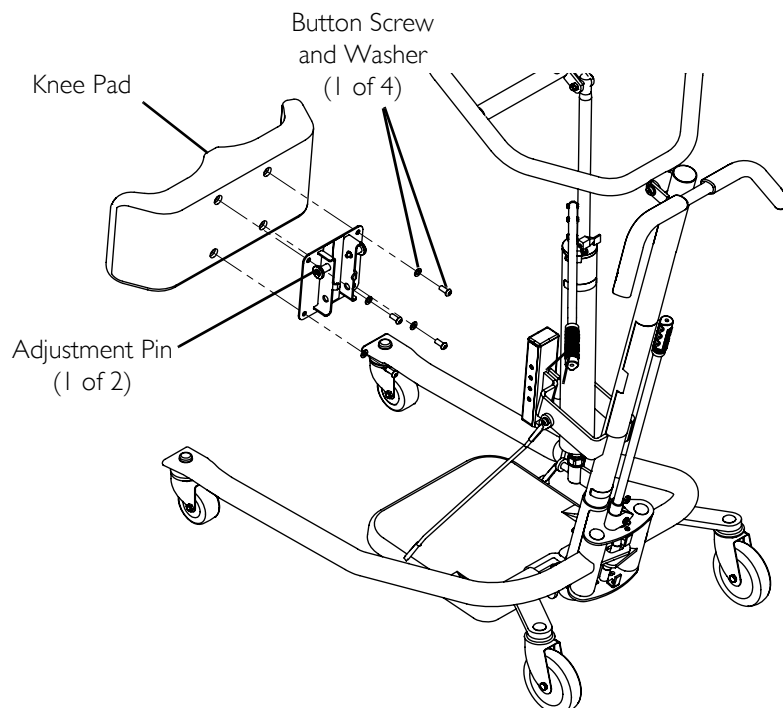

FIGURE 8.1 Replacing the Knee Pad

LIMITED WARRANTY

PLEASE NOTE: THE WARRANTY BELOW HAS BEEN DRAFTED TO COMPLY WITH FEDERAL LAW APPLICABLE TO PRODUCTS MANUFACTURED AFTER JULY 4, 1975.

This warranty is extended only to the original purchaser/user of our products.

This warranty gives you specific legal rights and you may also have other legal rights which vary from state to state.

Invacare warrants the products manufactured to be free from defects in materials and workmanship for a period of three years on the lift and one year on the hydraulic pump from the date of purchase. If within such warranty period any such product shall be proven to be defective, such product shall be repaired or replaced, at Invacare's option. This warranty does not include any labor or shipping charges incurred in replacement part installation or repair of any such product. Invacare's sole obligation and your exclusive remedy under this warranty shall be limited to such repair and/or replacement.

For warranty service, please contact the dealer from whom you purchased your Invacare product. In the event you do not receive satisfactory warranty service, please write directly to Invacare at the address on the back cover, provide dealer's name, address, date of purchase, indicate nature of the defect.

Invacare Corporation will issue a serialized return authorization. The defective unit or parts **MUST** be returned for warranty inspection using the serial number, when applicable as identification within 30 days of return authorization date. Do not return products to our factory without our prior consent. C.O.D. shipments will be refused; please prepay shipping charges.

LIMITATIONS AND EXCLUSIONS: THE FOREGOING WARRANTY SHALL NOT APPLY TO SERIAL NUMBERED PRODUCTS IF THE SERIAL NUMBER HAS BEEN REMOVED OR DEFACED, PRODUCTS SUBJECTED TO NEGLIGENCE, ACCIDENT, IMPROPER OPERATION, MAINTENANCE OR STORAGE, PRODUCTS MODIFIED WITHOUT INVACARE'S EXPRESS WRITTEN CONSENT (INCLUDING, BUT NOT LIMITED TO, MODIFICATION THROUGH THE USE OF UNAUTHORIZED PARTS OR ATTACHMENTS; PRODUCTS DAMAGED BY REASON OF REPAIRS MADE TO ANY COMPONENT WITHOUT THE SPECIFIC CONSENT OF INVACARE, OR TO A PRODUCT DAMAGED BY CIRCUMSTANCES BEYOND INVACARE'S CONTROL, AND SUCH EVALUATION WILL BE SOLELY DETERMINED BY INVACARE. THE WARRANTY SHALL NOT APPLY TO PROBLEMS ARISING FROM NORMAL WEAR OR FAILURE TO ADHERE TO THE INSTRUCTIONS IN THIS MANUAL.

THE FOREGOING EXPRESS WARRANTY IS EXCLUSIVE AND IN LIEU OF ANY OTHER WARRANTIES WHATSOEVER, WHETHER EXPRESS OR IMPLIED, INCLUDING THE IMPLIED WARRANTIES OF MERCHANTABILITY AND FITNESS FOR A PARTICULAR PURPOSE, AND THE SOLE REMEDY FOR VIOLATIONS OF ANY WARRANTY WHATSOEVER, SHALL BE LIMITED TO REPAIR OR REPLACEMENT OF THE DEFECTIVE PRODUCT PURSUANT TO THE TERMS CONTAINED HEREIN. THE APPLICATION OF ANY IMPLIED WARRANTY WHATSOEVER SHALL NOT EXTEND BEYOND THE DURATION OF THE EXPRESS WARRANTY PROVIDED HEREIN. INVACARE SHALL NOT BE LIABLE FOR ANY CONSEQUENTIAL OR INCIDENTAL DAMAGES WHATSOEVER.

SOME STATES DO NOT ALLOW EXCLUSION OR LIMITATION OF INCIDENTAL OR CONSEQUENTIAL DAMAGE, OR LIMITATION ON HOW LONG AN IMPLIED WARRANTY LASTS, SO THE ABOVE EXCLUSIONS AND LIMITATIONS MAY NOT APPLY TO YOU.

THIS WARRANTY SHALL BE EXTENDED TO COMPLY WITH STATE OR PROVINCIAL LAWS AND REQUIREMENTS.



Yes, you can.[®]

Invacare Corporation

USA
One Invacare Way
Elyria, Ohio USA
44036-2125
800-333-6900

www.invacare.com

Canada
570 Matheson Blvd E Unit 8
Mississauga Ontario
L4Z 4G4 Canada
800-668-5324

All rights reserved. Trademarks are identified by the symbols [™] and [®]. All trademarks are owned by or licensed to Invacare Corporation or its subsidiaries unless otherwise noted.

© 2009 Invacare Corporation

Part No 1148115

Rev B - 06/09

