

**105TX-POE & 105FX-POE
Unmanaged Industrial Ethernet
POE Switches**

**User Manual &
Installation
Guide**

Industrial Power over Ethernet Installation Guide

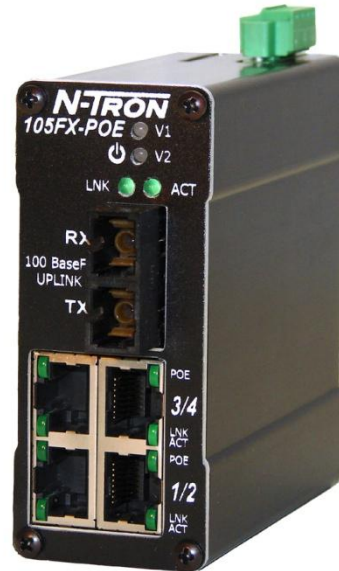

105TX-POE

105FX-XX-POE

105FXE-XX-YY-POE

Where: **XX = ST or SC and YY = -15, -40, or -80**

Copyright, © N-TRON Corp., 2008
820 S. University Blvd., Suite 4E
Mobile, AL USA 36609

All rights reserved. Reproduction, adaptation, or translation without prior written permission from N-TRON Corp. is prohibited, except as allowed under copyright laws.

Ethernet is a registered trademark of Xerox Corporation. All other product names, company names, logos or other designations mentioned herein are trademarks of their respective owners.

The information contained in this document is subject to change without notice. N-TRON Corp. makes no warranty of any kind with regard to this material, including, but not limited to, the implied warranties of merchantability or fitness for a particular purpose. In no event shall N-TRON Corp. be liable for any incidental, special, indirect or consequential damages whatsoever included but not limited to lost profits arising out of errors or omissions in this manual or the information contained herein.

Contact Information :

N-TRON Corp.
820 South University Blvd.
Suite 4E
Mobile, AL 36609
TEL: (251) 342-2164
FAX: (251) 342-6353
Website: www.n-tron.com
Email: N-TRON_Support@n-tron.com

GENERAL SAFETY WARNINGS

WARNING: Do not operate the equipment in the presence of flammable gasses or fumes. Operating electrical equipment in such an environment constitutes a definite safety hazard.

WARNING: If the equipment is used in the manner not specified by N-TRON Corp., the protection provided by the equipment may be impaired.

WARNING: Do not perform any services on the unit unless qualified to do so. Do not substitute unauthorized parts or make unauthorized modifications to the unit.

WARNING: Do not operate the unit with the end plates removed, as this could create a shock or fire hazard.

WARNING: Do not operate the equipment in a manner not specified by this manual.

ENVIRONMENTAL SAFETY WARNINGS



WARNING: Disconnect the power and allow to cool 5 minutes before touching.

ELECTRICAL SAFETY WARNINGS



WARNING: Disconnect the power cable before removing the end plates.

WARNING: Do not operate the unit with the end plates removed.

WARNING: Properly ground the unit before connecting anything else to the unit. Units not properly grounded may result in a safety risk and could be hazardous and may void the warranty. See the grounding technique section of this user manual for proper ways to ground the unit.

WARNING: Do not work on equipment or cables during periods of lightning activity.

WARNING: Do not perform any services on the unit unless qualified to do so.

WARNING: Observe proper DC Voltage polarity when installing power input cables. Reversing voltage polarity can cause permanent damage to the unit and void the warranty.

HAZARDOUS LOCATION INSTALLATION REQUIREMENTS

1. This equipment is suitable for use in Class I, Div 2, Groups A, B, C, and D, or unclassified or non-hazardous locations only.
2. **WARNING:** Explosion Hazard - Substitution of components may impair suitability for Class I, Division 2.
3. **WARNING:** Explosion hazard, do not disconnect while the circuit is live or unless the area is known to be non-hazardous.
4. **WARNING:** Explosion Hazard - Do not remove or replace the device unless power has been switched off or the area is known to be non-hazardous.
5. Use 60/75°C rated Copper wire, (0.22Nm) 2 inch-lbs Tightening torque for field installed connectors.
6. **WARNING:** Install only in accordance with Local & National Codes of Authorities Having Jurisdiction.
7. Class I, Div 2 installations require that all devices connected to this product must be UL listed for the area in which it is installed.
8. **WARNING:** Damage may occur to the RJ-45 port of the powered device (PD), if the switch is not powered down before disconnecting the Cat5 cable.

Functional Overview

The 105TX-POE and 105FX-POE Power over Ethernet Unmanaged Industrial Ethernet Switches are designed to provide power over Ethernet for POE capable devices where running a power line is either not possible or not cost effective. This feature allows an end user to power a POE camera, wireless access point, or any other POE capable device without the need for running separate wires for power. This also allows the ability for a centralized battery backup for all these devices.

The 105FX-POE utilizes the IEEE compliant SC or ST duplex connectors for fiber optic communication. All 10/100Base-TX ports utilize the RJ45 shielded connectors.

Key Features

- Compact, space saving package
- Full IEEE 802.3 & 100Base-FX Compliance
- IEEE 802.3af Compliant
- **105TX-POE** - Five 10/100Base-TX RJ-45 ports (4 PSE ports and 1 uplink port)
- **105FX-POE** - Four 10/100Base-TX RJ-45 ports (4 PSE ports and 1 100BaseFX fiber uplink port)
- Unmanaged operation
- Extended Environmental Specifications
 - 40°C to 85°C Operating Temperature
 - 40°C to 85°C Storage Temperature
- Operating Humidity: 10% to 90% (Non Condensing)
- Support for Full/Half Duplex Operation
- LED Link/Activity Status Indication
- LED POE Status Indication
- Power Fault Status LEDs
- Auto-negotiation, Auto-sensing Speed, Duplex, and Flow Control
- Up to 1.0 Gb/s Maximum Throughput
- Industry Standard 35mm DIN Rail Mounted Enclosure
- Redundant power inputs (46-49 VDC)
- Supports up to 15.4Watts per channel (13 Watts at the Powered Device (PD))
- Full wire speed communications
- Hardened metal DIN Rail Enclosure



PACKAGE CONTENTS

Please make sure the switch package contains the following items:

1. 105TX-POE or 105FX(E)-POE
2. Instruction Sheet

Contact your carrier if any items are damaged.

UNPACKING

Remove all the equipment from the packaging, and store the packaging in a safe place. File any damage claims with the carrier.

CLEANING

Clean only with a damp cloth.

INSTALLATION

Read the following warnings before beginning the installation:

WARNING



Never install or work on electrical equipment or cabling during periods of lightning activity. Never connect or disconnect power when hazardous gasses are present.

LASER SAFETY (105FXE -40 and -80 Only)



CAUTION: CLASS 1 LASER PRODUCT. Do not stare into the laser!

DIN-Rail Mounting

Install the unit in a standard DIN rail. Recess the unit to allow at least 2" of horizontal clearance for CAT5e cable bend radius.

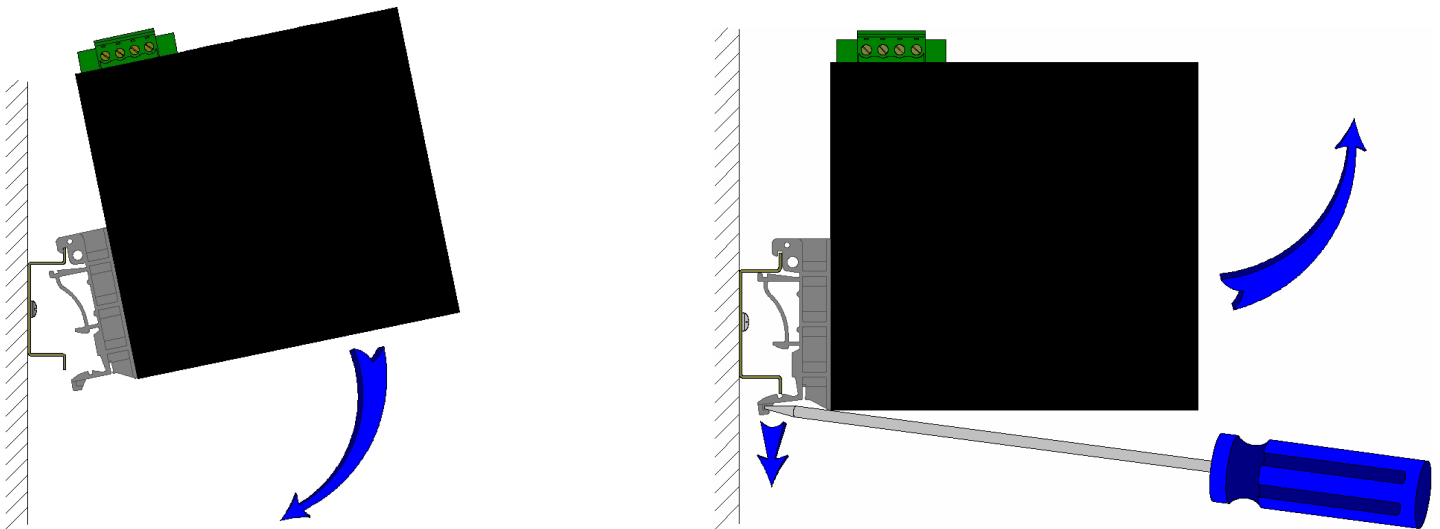

To install the unit to 35mm industrial DIN rail, place the top edge of the included mounting bracket on the back of the unit against the DIN rail at a 15° angle as shown. Rotate the bottom of the unit to the back (away from you) until it snaps into place.

To remove the unit from the 35mm industrial DIN rail, place a flat head screwdriver into the release clip found at the bottom of the unit, and apply downward force on the clip until it disengages from the bottom of the unit from the DIN rail. Rotate the bottom of the unit towards you and up at an approximate 15° upward angle to completely remove the unit.

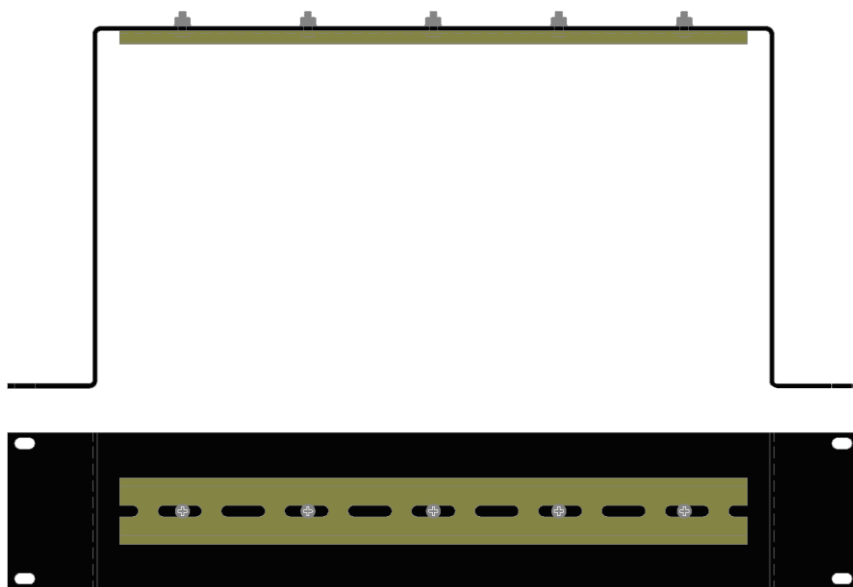

Most N-Tron™ products are designed to be mounted on industry standard 35mm DIN rail. However, DIN rail mounting may not be suitable for all applications. Our Universal Rack Mount Kit (P/N: URMK) may be used to mount the 105TX/FX-POE enclosures to standard 19" racks as an option.

FRONT PANEL



From Top to Bottom:

	Power LED
	POE Status LED
	Speed LED (105TX-POE only)
	Link/Activity LED
	Auto sensing 10/100BaseT Connection

LED MODE OF OPERATION

LED	Color	Description
V1	Green	Valid Power (46-54 VDC) is applied
	Red	Invalid Power (<46 VDC) is applied or Power Bus Fault detected
	OFF	No Power is applied to the device
V2	Green	Valid Power (46-54 VDC) is applied
	Red	Invalid Power (<46 VDC) is applied or Power Bus Fault detected
	OFF	No Power is applied to the device
POE	Green	POE is being applied on the respective port
	Blinking	POE PD detected with improper power classification
	OFF	No POE PD detected on the port
LNK ACT	Green	Link with no or little activity
	Blinking	Link with activity
	OFF	No link established
SPD 100	Green	100 Base
	OFF	10 Base
LNK	Green	Link established on the fiber uplink port (105FX-POE)
	OFF	No link established on fiber uplink port (105FX-POE)
ACT	Blinking	Activity present
	OFF	No activity

Note: Redundant power inputs will not balance the power load. Only load from one power supply is used at a time.

APPLYING POWER (Top View)

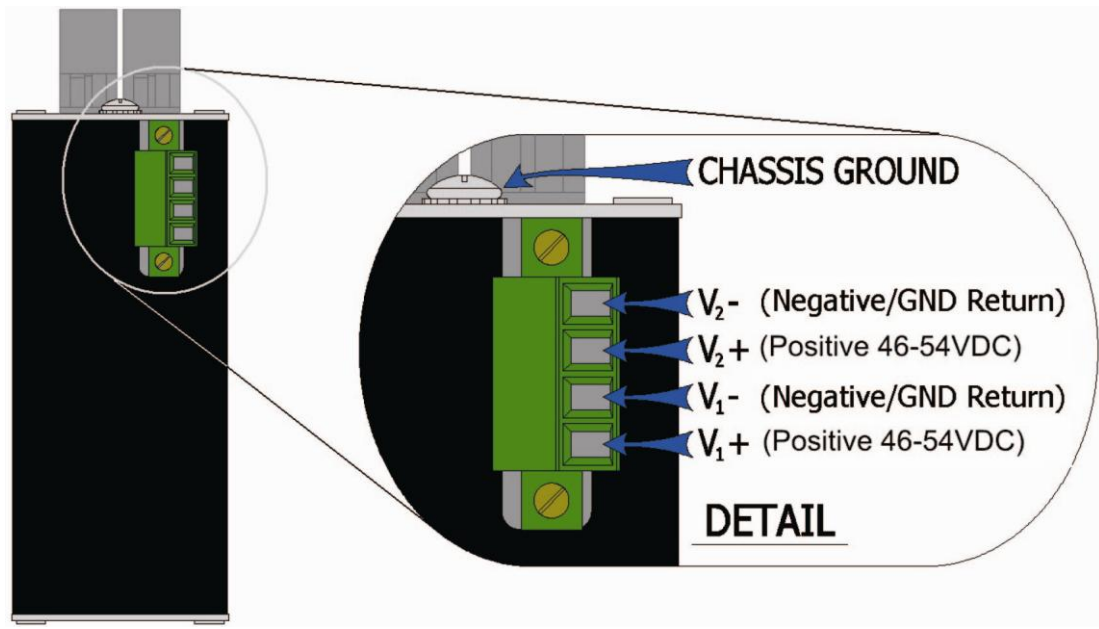

Unscrew & Remove the DC Voltage Input Plug from the top header.

Install the DC Power Cables into the Plug (observing polarity on unit).

Plug the Voltage Input Plug back into the top header.

Tightening torque for the terminal block power plug is **0.22 Nm/0.162 Pound Foot**.

Turn the power on the wire.

Note: It is only safe to turn the power on the wires after the wires have been secured to the switch.

WARNING: Inserting the input plug while the 48VDC is applied may cause arcing, and damage the input connector permanently.

Note: Either V_1 or V_2 can be connected to power for minimal operation. For redundant power operation, V_1 and V_2 plugs must be connected to separate DC Voltage sources. Use wire sizes of 10-20 gauge. The power cord should be limited to less than 10 meters in order to ensure optimum performance.

Recommended 48V DC Power Supplies, similar to:

100-240VAC:

N-Tron NTPS-48-5, DC 48V/5A

N-TRON GROUNDING TECHNIQUES FOR 105TX-POE AND 105FX-POE

The grounding philosophy of any control system is an integral part of the design. N-Tron switches are designed to be grounded, but the user has been given the flexibility to float the switch when required. The best noise immunity and emissions (i.e. CE) are obtained when the N-Tron switch chassis is connected to earth ground via a drain wire. Some N-Tron switches have metal din-rail brackets that can ground the switch if the din-rail is grounded. In some cases, N-Tron switches with metal brackets can be supplied with optional plastic brackets if isolation is required.

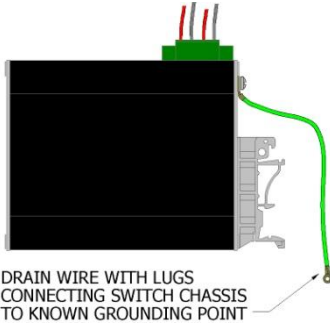

Users may run a drain wire & lug from the screw provided on the back face of the enclosure. In the event the provided grounding screw has been lost, care should be taken to limit the penetration of the outer skin by less than 1/4". Failure to do so may cause irreversible damage to the internal components of the switch.

Note: Ensure the power supply is grounded properly before applying power to the grounded switch. This may be verified by using a voltmeter to determine that there is no voltage difference between the power supply's negative output terminal and the chassis grounding point of the switch.

As an alternative grounding method, both V- legs of the power input connector are connected to chassis internally on the PCB. Connecting a drain wire to earth ground from one of the V- terminal plugs as shown here will ground the switch and the chassis. The power leads from the power source should be limited to 3 meters or less in length.

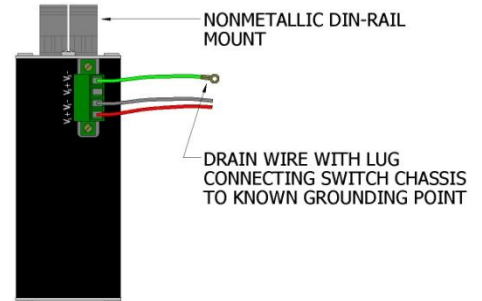

If the use of shielded cables is required, it is generally recommended to only connect the shield at one end to prevent ground loops and interfere with low level signals (i.e. thermocouples, RTD, etc.). Cat5e cables manufactured to EIA-568A or 568B specifications are required for use with N-Tron Switches.



In the event all Cat5e patch cable distances are small (i.e. All Ethernet devices are located the same local cabinet and/or referenced to the same earth ground), it is permissible to use fully shielded cables terminated to chassis ground at both ends in systems void of low level analog signals.

RJ45 CONNECTOR CRIMP SPECIFICATIONS

Please reference the illustration below for your Cat5 cable specifications:

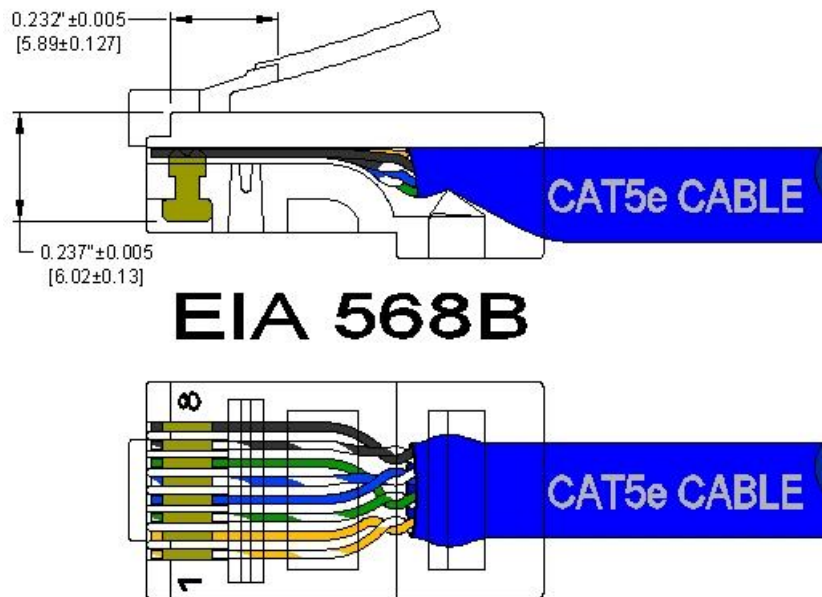

TYPICAL APPLICATIONS

STAR TOPOLOGY

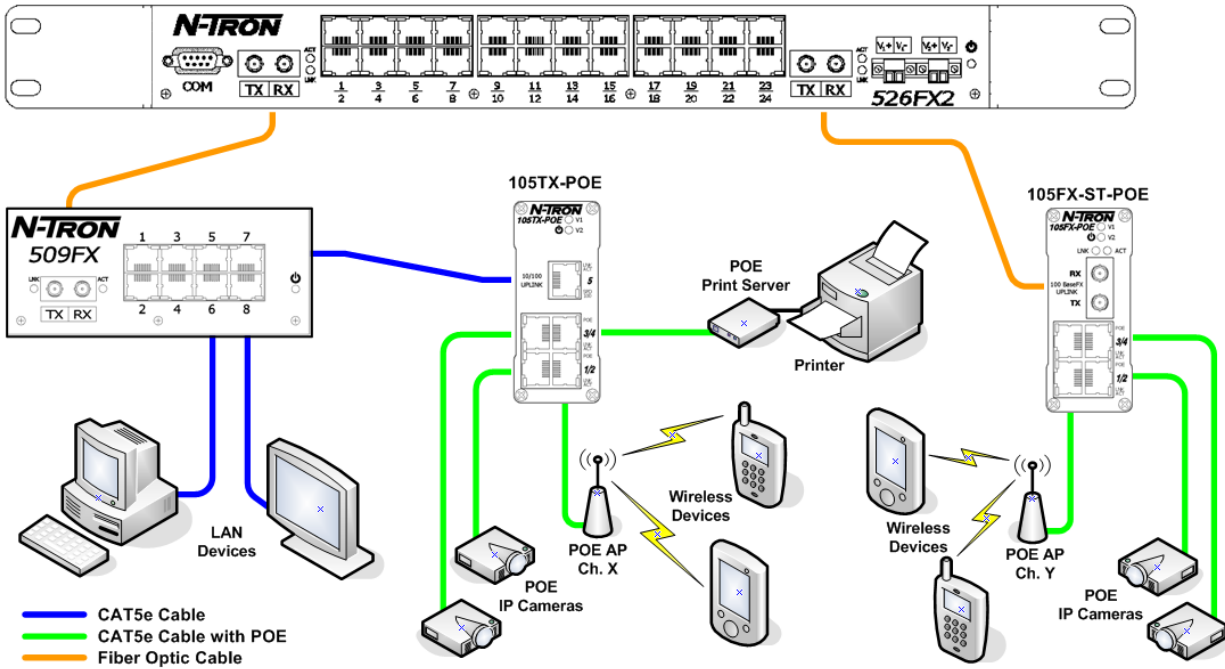

RING TOPOLOGY

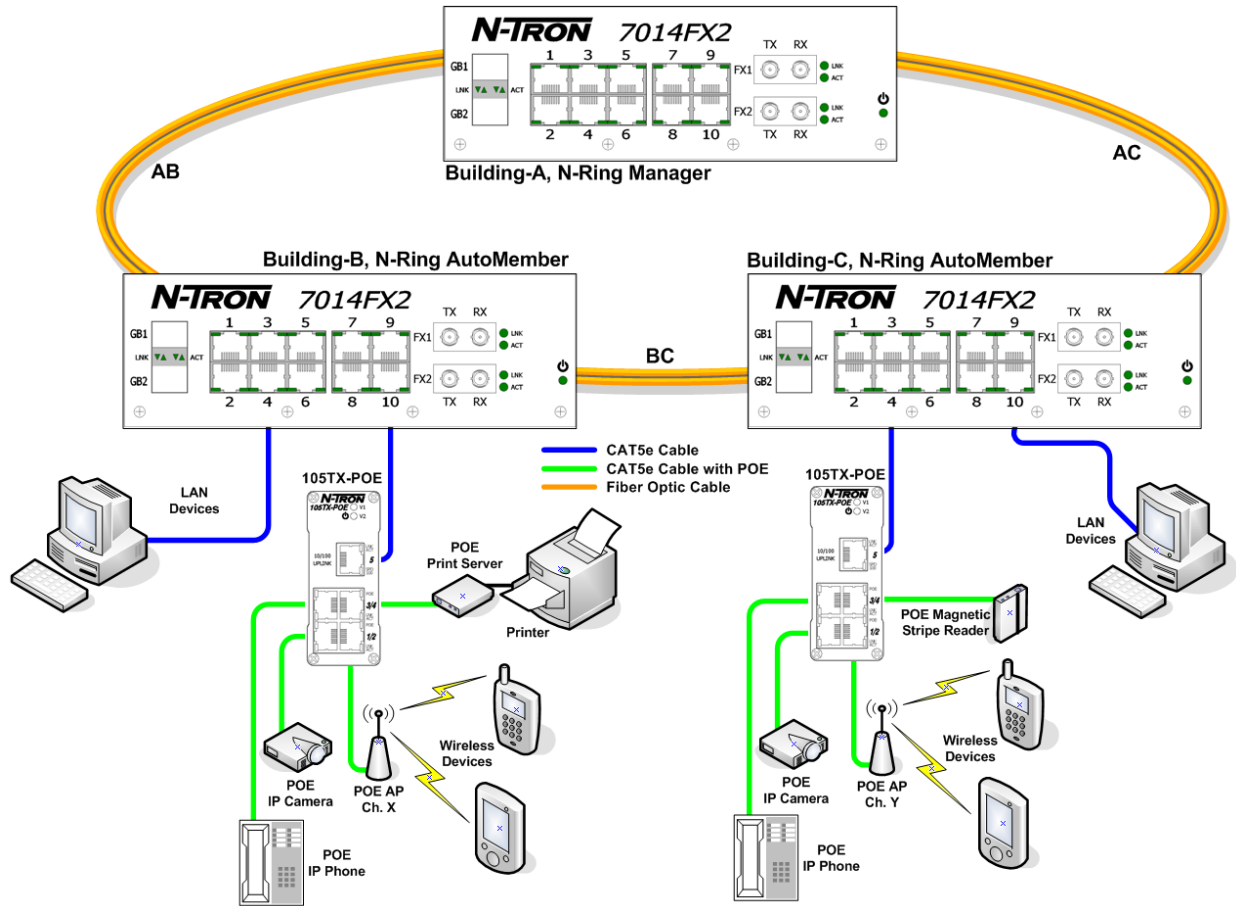

CONNECTING THE UNIT

For the 100BaseFX Fiber Optic port (105FX-POE), remove the dust cap(s) from the fiber optic connector and connect the fiber optic cables. The TX port on the local unit should be connected to the RX port of the far end device, and the RX port should be connected to the TX port of the far end device.

For 10Base-T ports, plug a Category 3 (or greater) twisted pair cable into the RJ45 connector. For 100Base-T ports, plug a Category 5 (or greater) twisted pair cable into the RJ45 connector. Connect the other end to the far end station. Verify that the LNK LED's are ON once the connection has been completed. To connect any other port to another Switch or Repeater, use a standard Cat5 straight through or crossover cable.

Warning: Creating a port to port connection on the same switch (i.e. loop) is an illegal operation and will create a broadcast storm which will crash the network!

TROUBLESHOOTING

1. Make sure the  (Power LED) is ON.
2. Make sure you are supplying sufficient current for the 105TX-POE or 105FX-POE and all powered devices plugged into it. **Note: The inrush current and steady state current is dependent on the power requirements of the powered devices plugged into the POE switch.**
3. Verify that the POE light is on solid if a valid POE PD is connected to the port.
4. Verify that Link LED's are ON for both ports.
5. Verify cabling used between stations.
6. Verify that cabling is Category 3 or greater for 10Mbit Operation.

FCC STATEMENT

This product complies with Part 15 of the FCC-A Rules.

Operation is subject to the following conditions:

- (1) This device may not cause harmful interference
- (2) This device must accept any interference received, including interference that may cause undesired operation.

NOTE: This equipment has been tested and found to comply with the limits for a Class A digital device, pursuant to Part 15 of the FCC Rules. These limits are designed to provide reasonable protection against harmful interference in a residential installation. This equipment generates, uses, and can radiate radio frequency energy and, if not installed and used in accordance with the instructions, may cause harmful interference to radio communications. Operation of this device in a residential area is likely to cause harmful interference in which case the user will be required to correct the interference at his own expense.

INDUSTRY CANADA

This Class A digital apparatus meets all requirements of the Canadian Interference Causing Equipment Regulations. Operation is subject to the following two conditions; (1) this device digital apparatus meets all requirements of the Canadian Interference Causing Equipment Regulations. Operation is subject to the following two conditions; (1) this device may not cause harmful interference, and (2) this device must accept any interference received, including interference that may cause undesired operation.

Cet appareillage numérique de la classe A répond à toutes les exigences de l'interférence canadienne causant des règlements d'équipement. L'opération est sujette aux deux conditions suivantes: (1) ce dispositif peut ne pas causer l'interférence nocive, et (2) ce dispositif doit accepter n'importe quelle interférence reçue, y compris l'interférence qui peut causer l'opération peu désirée.

Regulatory Approvals:

Safety: UL Listed per ANSI/ISA-12.12.01-2000 (US and Canada) is listed for use in Class I, Div 2, Groups A, B, C, D, T4

EMI: EN 61000-6-4, EN 55011 - Class A
FCC Title 47, Part 15, Subpart B - Class A
ICES-003 – Class A

EMS: EN6 1000-6-2
IEC 61000-4-2 (ESD)
IEC 1000-4-3 (RS)
IEC 61000-4-4 (EFT)
IEC 61000-4-5 (Surge)
IEC 61000-4-6 (Conducted Disturbances)

Warranty: 3 years from the date of purchase.

KEY SPECIFICATIONS

Physical

Height: 3.5" (8.89cm)
Width: 1.489" (3.78cm)
Depth: 3.53" (8.96cm)
Weight: 0.7 lbs. (0.31kg)

Electrical

Input Voltage: 46-49 VDC
Input Current: 1.6 A @ 48 VDC (under full load)
65 mA @ 48 VDC (no POE in use, switch in full use)
Inrush Current: 26 Amp/1.3 ms @ 48VDC
Input Ripple: Less than 100 mV
Input Wire Size: 10-20 AWG

Environmental

Operating Temperature: -40°C to 85°C
Storage Temperature: -40°C to 85°C
Operating Humidity: 10% to 90% (Non Condensing)
Operating Altitude: 0 to 10,000 ft.

Network Media

10BaseT: > Cat-3 Cable
100BaseT: > Cat-5 Cable
100BaseFX: Multimode: 50-62.5/125µm Fiber
Singlemode: 7-10/125µm Fiber

Fiber Transceiver Characteristics

Fiber Length:	2km*	15km**	40km**	80km**
TX Power Min	-19dBm	-15dBm	-5dBm	-5dBm
RX Sensitivity Max:	-31dBm	-31dBm	-34dBm	-34dBm
Wavelength:	1310nm	1310nm	1310nm	1550nm

*=Multimode ** =Singlemode

Connectors

10/100BaseTX: RJ45 UTP Port
100BaseFX: SC or ST Duplex Port

Recommended Minimum Wiring Clearance:

Top: 1 " (2.54 cm)
Front: 2 " (5.08 cm) TX model
Front: 4 " (10.16 cm) FX model

N-TRON Limited Warranty

N-TRON, Corp. warrants to the end user that this hardware product will be free from defects in workmanship and materials, under normal use and service, for the applicable warranty period from the date of purchase from N-TRON or its authorized reseller. If a product does not operate as warranted during the applicable warranty period, N-TRON shall, at its option and expense, repair the defective product or part, deliver to customer an equivalent product or part to replace the defective item, or refund to customer the purchase price paid for the defective product. All products that are replaced will become the property of N-TRON. Replacement products may be new or reconditioned. Any replaced or repaired product or part has a ninety (90) day warranty or the remainder of the initial warranty period, whichever is longer. N-TRON shall not be responsible for any custom software or firmware, configuration information, or memory data of customer contained in, stored on, or integrated with any products returned to N-TRON pursuant to any warranty.

OBTAINING WARRANTY SERVICE: Customer must contact N-TRON within the applicable warranty period to obtain warranty service authorization. Dated proof of purchase from N-TRON or its authorized reseller may be required. Products returned to N-TRON must be pre-authorized by N-TRON with a Return Material Authorization (RMA) number marked on the outside of the package, and sent prepaid and packaged appropriately for safe shipment. Responsibility for loss or damage does not transfer to N-TRON until the returned item is received by N-TRON. The repaired or replaced item will be shipped to the customer, at N-TRON's expense, not later than thirty (30) days after N-TRON receives the product. N-TRON shall not be responsible for any software, firmware, information, or memory data of customer contained in, stored on, or integrated with any products returned to N-TRON for repair, whether under warranty or not.

ADVANCE REPLACEMENT OPTION: Upon registration, this product qualifies for advance replacement. A replacement product will be shipped within three (3) days after verification by N-TRON that the product is considered defective. The shipment of advance replacement products is subject to local legal requirements and may not be available in all locations. When an advance replacement is provided and customer fails to return the original product to N-TRON within fifteen (15) days after shipment of the replacement, N-TRON will charge customer for the replacement product, at list price.

WARRANTIES EXCLUSIVE: IF AN N-TRON PRODUCT DOES NOT OPERATE AS WARRANTED ABOVE, CUSTOMER'S SOLE REMEDY FOR BREACH OF THAT WARRANTY SHALL BE REPAIR, REPLACEMENT, OR REFUND OF THE PURCHASE PRICE PAID, AT N-TRON'S OPTION. TO THE FULL EXTENT ALLOWED BY LAW, THE FOREGOING WARRANTIES AND REMEDIES ARE EXCLUSIVE AND ARE IN LIEU OF ALL OTHER WARRANTIES, TERMS, OR CONDITIONS, EXPRESS OR IMPLIED, EITHER IN FACT OR BY OPERATION OF LAW, STATUTORY OR OTHERWISE, INCLUDING WARRANTIES, TERMS, OR CONDITIONS OF MERCHANTABILITY, FITNESS FOR A PARTICULAR PURPOSE, SATISFACTORY QUALITY, CORRESPONDENCE WITH DESCRIPTION, AND NON-INFRINGEMENT, ALL OF WHICH ARE EXPRESSLY DISCLAIMED. N-TRON NEITHER ASSUMES NOR AUTHORIZES ANY OTHER PERSON TO ASSUME FOR IT ANY OTHER LIABILITY IN CONNECTION WITH THE SALE, INSTALLATION, MAINTENANCE OR USE OF ITS PRODUCTS. N-TRON SHALL NOT BE LIABLE UNDER THIS WARRANTY IF ITS TESTING AND EXAMINATION DISCLOSE THAT THE ALLEGED DEFECT OR MALFUNCTION IN THE PRODUCT DOES NOT EXIST OR WAS CAUSED BY CUSTOMER'S OR ANY THIRD PERSON'S MISUSE, NEGLIGENCE, IMPROPER INSTALLATION OR TESTING, UNAUTHORIZED ATTEMPTS TO OPEN, REPAIR OR MODIFY THE PRODUCT, OR ANY OTHER CAUSE BEYOND THE RANGE OF THE INTENDED USE, OR BY ACCIDENT, FIRE, LIGHTNING, POWER CUTS OR OUTAGES, OTHER HAZARDS, OR ACTS OF GOD.

LIMITATION OF LIABILITY: TO THE FULL EXTENT ALLOWED BY LAW, N-TRON ALSO EXCLUDES FOR ITSELF AND ITS SUPPLIERS ANY LIABILITY, WHETHER BASED IN CONTRACT OR TORT (INCLUDING NEGLIGENCE), FOR INCIDENTAL, CONSEQUENTIAL, INDIRECT, SPECIAL, OR PUNITIVE DAMAGES OF ANY KIND, OR FOR LOSS OF REVENUE OR PROFITS, LOSS OF BUSINESS, LOSS OF INFORMATION OR DATA, OR OTHER FINANCIAL LOSS ARISING OUT OF OR IN CONNECTION WITH THE SALE, INSTALLATION, MAINTENANCE, USE, PERFORMANCE, FAILURE, OR INTERRUPTION OF ITS PRODUCTS, EVEN IF N-TRON OR ITS AUTHORIZED RESELLER HAS BEEN ADVISED OF THE POSSIBILITY OF SUCH DAMAGES, AND LIMITS ITS LIABILITY TO REPAIR, REPLACEMENT, OR REFUND OF THE PURCHASE PRICE PAID, AT N-TRON'S OPTION. THIS DISCLAIMER OF LIABILITY FOR DAMAGES WILL NOT BE AFFECTED IF ANY REMEDY PROVIDED HEREIN SHALL FAIL OF ITS ESSENTIAL PURPOSE.

DISCLAIMER: Some countries, states, or provinces do not allow the exclusion or limitation of implied warranties or the limitation of incidental or consequential damages for certain products supplied to consumers or the limitation of liability for personal injury, so the above limitations and exclusions may be limited in their application to you. When the implied warranties are not allowed to be excluded in their entirety, they will be limited to the duration of the applicable written warranty. This warranty gives you specific legal rights which may vary depending on local law.

GOVERNING LAW: This Limited Warranty shall be governed by the laws of the State of Delaware, U.S.A.