



63xT Series AC & DC Powered (4-Wire) Process Current Isolators w/ Input Excitation

631T-0100 AC Powered Single Current Isolator

631T-0500 DC Powered Single Current Isolator

632T-0100 AC Powered Dual Current Isolator

632T-0500 DC Powered Dual Current Isolator

633T-0100 AC Powered Splitter (Single In/Dual Out) Isolator

633T-0500 DC Powered Splitter (Single In/Dual Out) Isolator

USER'S MANUAL



ACROMAG INCORPORATED
30765 South Wixom Road
P.O. BOX 437
Wixom, MI 48393-7037 U.S.A.

Tel: (248) 624-1541
Fax: (248) 624-9234

Copyright 2004-2011, Acromag, Inc., Printed in the USA.
Data and specifications are subject to change without notice.

8500-736-E11E002

TABLE OF CONTENTS

Symbols on equipment:



Means "Refer to User's Manual (this manual) for additional information".

The information of this manual may change without notice. Acromag makes no warranty of any kind with regard to this material, including, but not limited to, the implied warranties of merchantability and fitness for a particular purpose. Further, Acromag assumes no responsibility for any errors that may appear in this manual and makes no commitment to update, or keep current, the information contained in this manual. No part of this manual may be copied or reproduced in any form without the prior written consent of Acromag, Inc.

IMPORTANT SAFETY CONSIDERATIONS

You must consider the possible negative effects of power, wiring, component, sensor, or software failure in the design of any type of control or monitoring system. This is very important where property loss or human life is involved. It is important that you perform satisfactory overall system design and it is agreed between you and Acromag, that this is your responsibility.

GETTING STARTED

MOUNTING AND DIMENSIONS	3
CONTROLS & INDICATORS	3
ISOLATION BARRIERS	4
CONNECTIONS	5
DIN-Rail Mounting And Removal	5
Current Input(s)	5
Current Output(s)	6
Signal Splitter (633T)	6
Power	7
Earth Ground	8
CALIBRATION	8
Calibration Connections	8

TECHNICAL REFERENCE

KEY FEATURES	9
HOW IT WORKS	10
Simplified Schematic	10
SPECIFICATIONS	11
Model Numbers	11
Input	11
Output	11
Excitation Supply	11
General Specifications	11
Enclosure and Physical	12
Environmental	12
Agency Approvals	13
Controls & Indicators	13

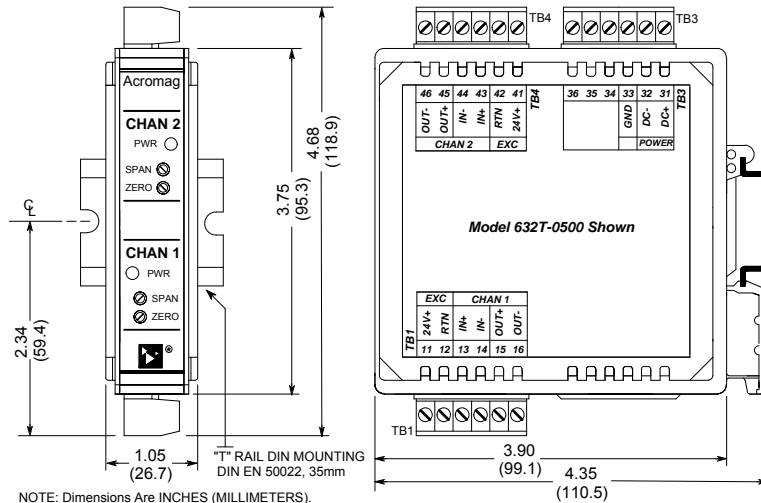

MODEL 631/632/633T ENCLOSURE DIMENSIONS

MODEL 631T-0500 & 631T-0100
SINGLE-CHANNEL CURRENT ISOLATOR

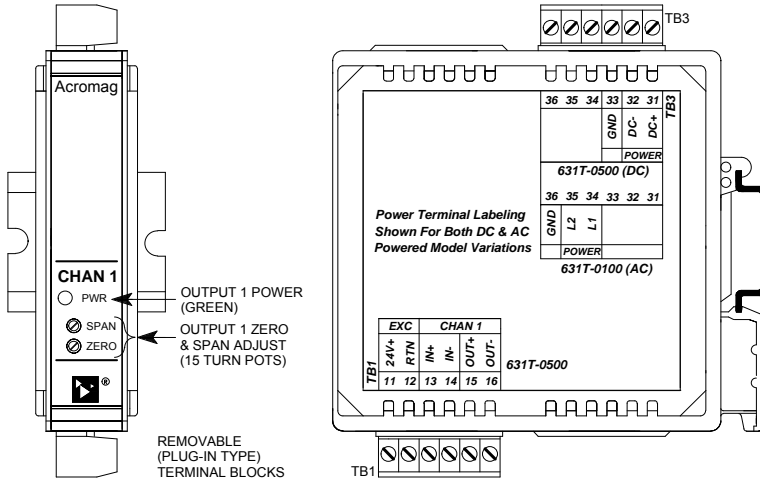

MODEL 632T-0500 & 632T-0100
DUAL-CHANNEL CURRENT ISOLATOR

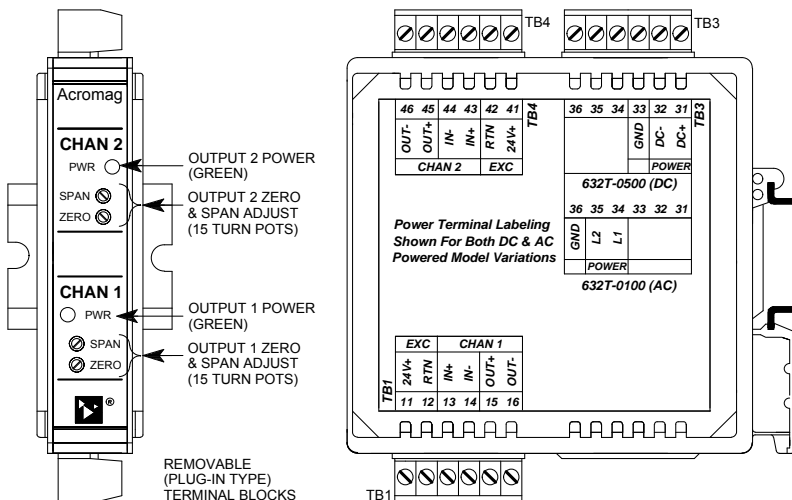

MOUNTING AND DIMENSIONS

Unit mounts to "T" type DIN rails (35mm, type EN50022).

Units may be mounted side-by-side on 1-inch centers.

WARNING: IEC Safety Standards may require that this device be mounted within an approved metal enclosure or sub-system, particularly for applications with exposure to voltages greater than or equal to 75VDC or 50VAC.

CONTROLS & INDICATORS

631T-0500 & 631T-0100 DC & AC Powered Single Channel Current Isolators

A Green Power LED is ON if power is on at the output.

A Zero Screw is used to calibrate the output range zero endpoint.

A Span Screw is used to calibrate the output range full-scale endpoint.

632T-0500 & 632T-0100 DC & AC Powered Dual Channel Current Isolators

A green Power LED for each output channel is ON if power is on at the channel.

A Zero Screw for each output channel is used to calibrate the output range zero endpoint.

A Span Screw for each output channel is used to calibrate the output range full-scale endpoint.

CONTROLS & INDICATORS

633T-0500 & 633T-0100 DC & AC Powered Single Input w/ Dual Output Channel Current Isolators

A green Power LED for each output channel is ON if power is on at the output channel.

A Zero Screw for each output channel is used to calibrate the channel's output range zero endpoint.

A Span Screw for each output channel is used to calibrate the channel's output range full-scale endpoint.

MODEL 633T-0500 & 633T-0100
SINGLE-INPUT & DUAL OUTPUT CURRENT ISOLATOR

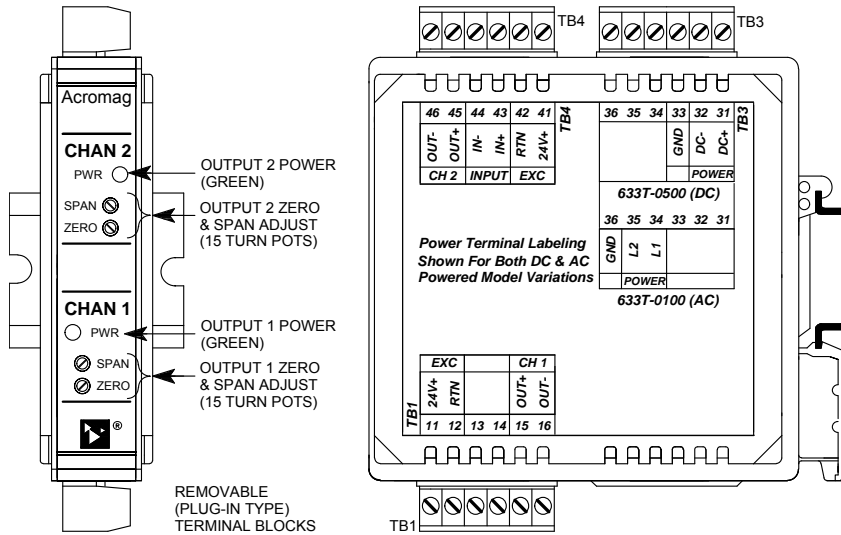

ISOLATION BARRIERS

Dashed Lines denote isolation barriers.

The input circuit(s), output circuit(s), excitation, and power circuit are isolated from each other for safety and noise immunity.

Note the 632T & 633T units include a single isolated EXC supply with two 24V current-limited outputs. The 631T includes a single isolated EXC supply with one 24V current limited output.

AC powered units ("-0100" suffix) are similar, except power is connected at different terminals.

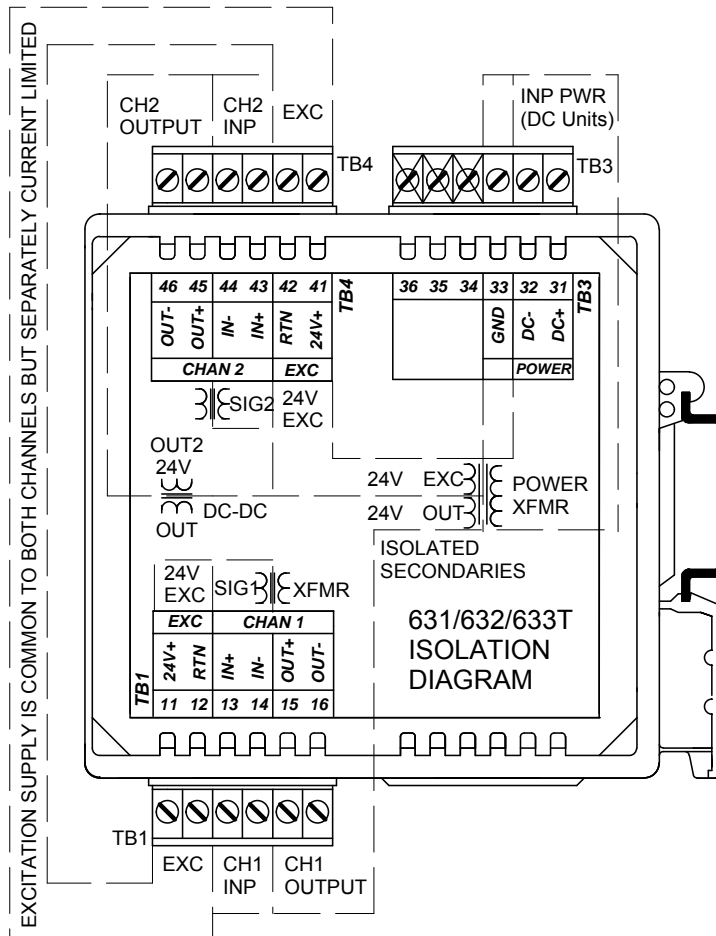

When attaching the module to the T-type DIN rail, angle the top of the unit towards the rail and locate the top groove of the adapter over the upper lip of the rail. Firmly push the unit towards the rail until it snaps into place. To remove, first separate the I/O terminal block(s) from the bottom side of the module to create a clearance to the DIN mounting area. Next, while holding the module in place from above, insert a screwdriver into the lower arm of the DIN rail connector and use it as a lever to force the connector down until the unit disengages from the rail (do not twist the screwdriver to avoid damaging plastic).

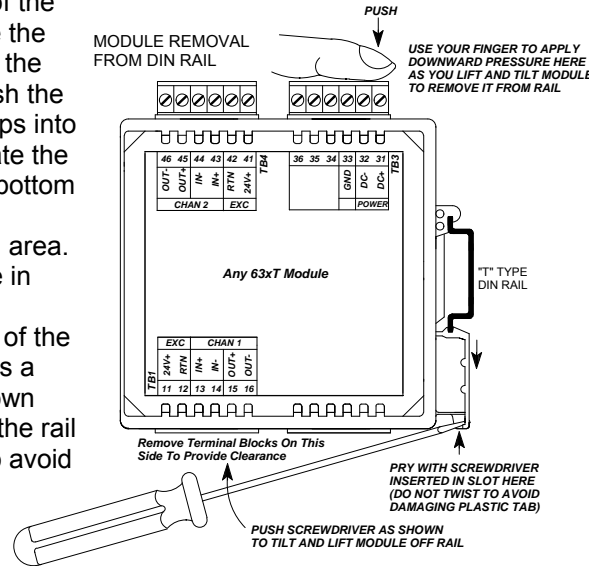

CONNECTIONS

DIN-Rail Mounting & Removal

- ✓ Connect your DC current input signal to the input terminals as shown below according to your input source. Repeat this connection for the second input channel of 632T units at TB4. Use input channel 2 at TB4 when connecting to 633T units.

INPUT CONNECTIONS TO CURRENT SOURCE

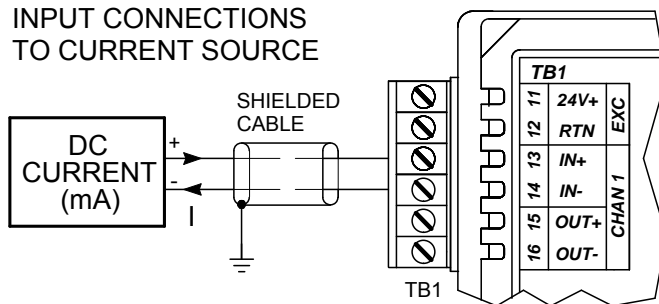

Input is DC current only.

632T inputs are isolated channel-to-channel.

633T input is connected to input 2 at TB4.

2-WIRE INPUT TRANSMITTER CONNECTIONS USING INTERNAL EXCITATION SOURCE POWER

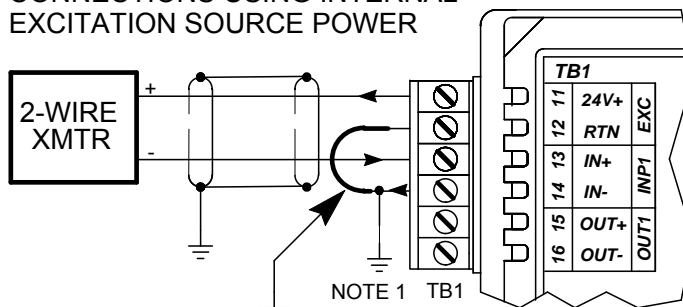

NOTE 1: IMPORTANT: REMOVE RTN JUMPER IF AN EXTERNAL EXCITATION SUPPLY IS USED.

Two-Wire Transmitter Connections With Input Excitation Loop Power.

Excitation supply outputs are separately current limited to 23mA each.

The excitation supply output is isolated from the input circuit. As such, EXC RTN and IN- must be jumpered together to complete the circuit as shown at right. Do not include the RTN jumper if an external excitation supply is used.

NOTE 1: THIS GROUND CONNECTION IS RECOMMENDED FOR BEST RESULTS. IF SENSORS ARE INHERENTLY CONNECTED TO GROUND, USE CAUTION TO AVOID MAKING ADDITIONAL GROUND CONNECTIONS WHICH COULD GENERATE GROUND LOOPS AND MEASUREMENT ERROR.

CONNECTIONS

Current Input(s)

Four-Wire Transmitter Connections

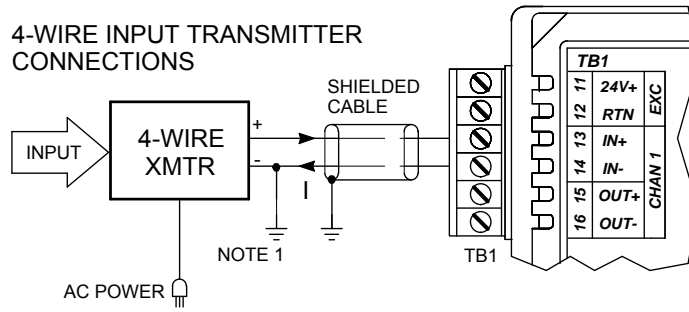

NOTE 1: THIS GROUND CONNECTION IS RECOMMENDED FOR BEST RESULTS. IF SENSORS ARE INHERENTLY CONNECTED TO GROUND, USE CAUTION TO AVOID MAKING ADDITIONAL GROUND CONNECTIONS WHICH COULD GENERATE GROUND LOOPS AND MEASUREMENT ERROR.

Current Output(s)

- ✓ Connect your output load to the output terminals as shown below. Repeat this connection for the second output channel of 632T and 633T units.

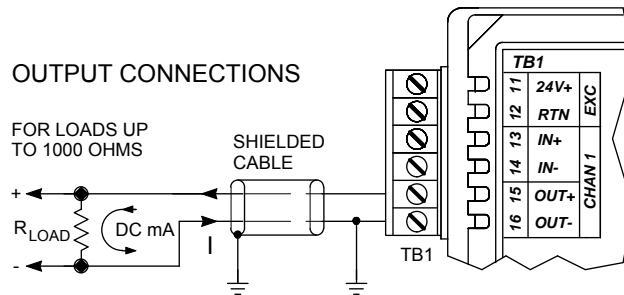

Signal Splitter (633T)

NOTE: DUAL OUTPUTS OF 633T-0x00 ARE FULLY INDEPENDENT AND ISOLATED FROM ONE ANOTHER. FOR ANY OUTPUT FAULT CONDITION (OPEN OR SHORT), THE OPPOSITE OUTPUT AND THE INPUT ARE NOT AFFECTED.

NOTE: 633T-0x00 MODELS MAY USE ONE OR BOTH EXCITATION SUPPLY CONNECTIONS.

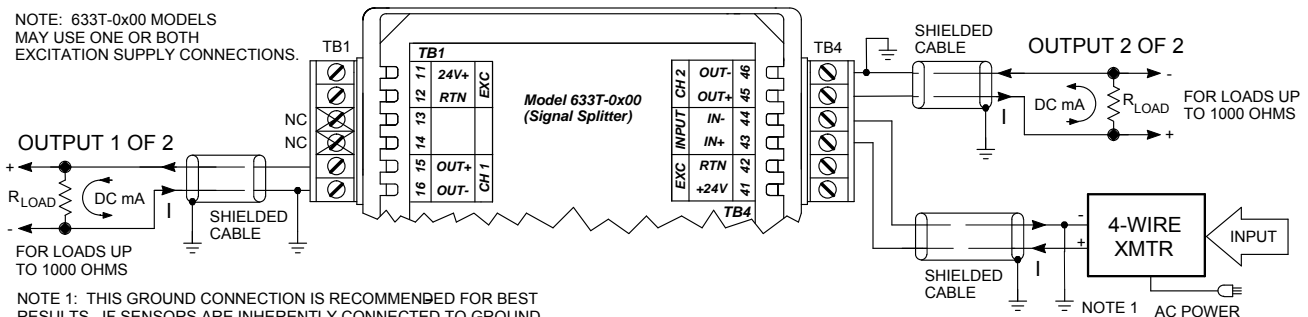

NOTE 1: THIS GROUND CONNECTION IS RECOMMENDED FOR BEST RESULTS. IF SENSORS ARE INHERENTLY CONNECTED TO GROUND, USE CAUTION TO AVOID MAKING ADDITIONAL GROUND CONNECTIONS WHICH COULD GENERATE GROUND LOOPS AND MEASUREMENT ERROR.

- ✓ **DC Power (“-0500” Units):** Connect 12-36V DC to the power terminals labeled DC+ & DC-. Observe proper polarity. For supply connections, use No. 14 AWG wires rated for at least 75°C.
CAUTION: Do not exceed 36VDC peak.

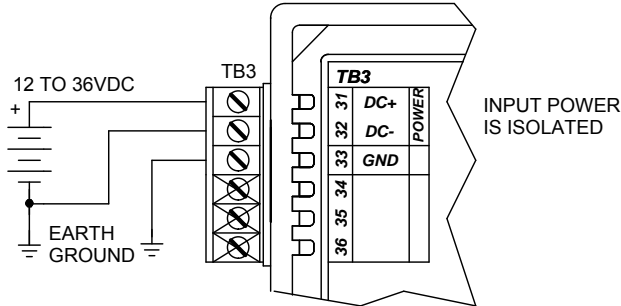

IMPORTANT (Dual channel 632/633T-0500 models) – If internal excitation is used, the minimum supply voltage is raised to 15VDC (“-0500” units) and 100VAC (“-0100” units).

WARNING: DO NOT CONNECT AC POWER TO A DC POWERED UNIT OR DAMAGE TO THE UNIT WILL OCCUR. Refer to your module’s label and verify that your model number has a “-0100” suffix before connecting unit to AC power.

IMPORTANT – External Fuse, DC Units: If unit is powered from a supply capable of delivering more than 1A to the unit, it is recommended that this current be limited via a high surge tolerant fuse rated for a maximum current of 1A or less (see External Fuse Selection at left).

- ✓ **AC Power (“-0100” Units):** Connect 90-250V AC or 125V DC±10% to the power terminals labeled L1 (Hot) & L2 (Neutral). Connect earth ground to the G (Ground) terminal. Observe proper polarity. For supply connections, use No. 14 AWG wires rated for at least 75°C.
CAUTION: Do not exceed 250V AC rms.

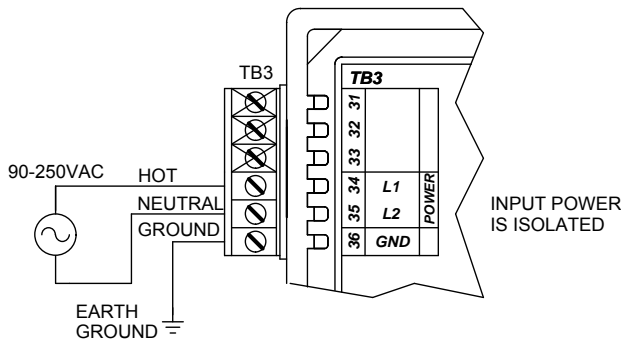

CAUTION: Risk of Electric Shock – More than one disconnect switch may be required to de-energize this equipment before servicing.

CONNECTIONS

Power

Voltage	Current
<i>(Output/EXC 20mA each)</i>	
632/633T-0500 w/EXC	
12VDC	419mA
15VDC	317mA
24VDC	179mA
36VDC	121mA
631T-0500 w/EXC	
12VDC	182mA
15VDC	142mA
24VDC	91mA
36VDC	67mA
632/633T-0100 w/EXC	
125VDC	33mA
115VAC	75mA rms
230VAC	41mA rms
631T-0100 w/EXC	
125VDC	18mA
115VAC	42mA rms
230VAC	25mA rms

External Fuse Selection:

Select a time-lag or high surge tolerant fuse. DC powered units may be fused with a high surge tolerant fuse rated for maximum current of 1A or less (see Bel Fuse MJS1). AC powered units may be fused via a 500mA, 250VAC rated time-lag fuse (example: Bel Fuse MRT500, 3JS500, or equivalent).

Earth Ground

- ✓ Connect Earth Ground as shown in the connection drawings above.

The plastic module housing does not require earth ground.

The ground connections noted are recommended for best results. If sensors are already grounded, use caution and avoid making additional ground connections which could create ground loops.

Warning: To comply with safety and performance standards, use shielded cable and connect earth ground as noted. Failure to use good wiring and grounding practices may be unsafe and hurt performance.

CALIBRATION

IMPORTANT: This module has already been calibrated at the factory and recalibration is not normally required, except as necessary to correct for long term component aging, or to satisfy your company's maintenance requirements. Do not attempt to recalibrate this module unless absolutely required, as miscalibration will negatively affect the module's performance.

TIP: Verify that current meter range is properly set to measure DC current for a 0-25mA DC range. If no reading is obtained on current meter, check that the meter has power or that its fuse is not blown.

To help prevent ESD damage to the circuit, use a grounded screwdriver to make zero and span adjustments.

Calibration is performed as an iterative process of zero and span adjustment for each output channel. The zero and span adjustment potentiometers are accessible from the front panel of the unit. Always start by calibrating zero first, before span. Further, allow the module to warm up a few minutes prior to calibration. The screwdriver blade used to adjust these pots should not be more than 0.1 inch (2.54mm) wide.

Equipment Required

- An accurate input current source adjustable for 4 and 20 mA DC. Source should be accurate to better than $\pm 0.05\%$ for best results.
- An current or voltage meter accurate to better than $\pm 0.05\%$ is required to monitor the output level.
- A precision current meter, or a precision load resistance and volt meter will be needed to monitor the output current for calibration.

Your success in recalibrating the output will strongly depend upon the accuracy and precision of your signal source and measurement system.

EXAMPLE CALIBRATION CONNECTIONS

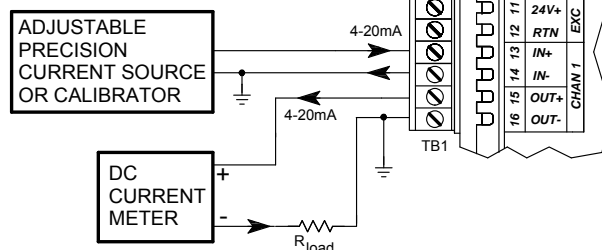

ALTERNATE CALIBRATION CONNECTIONS

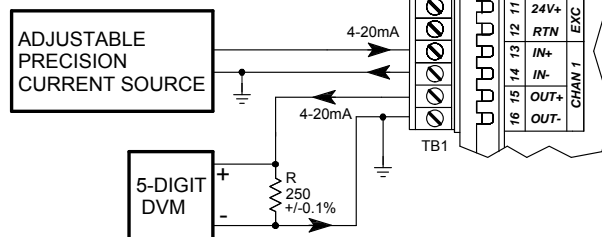

Adjustment Procedure

1. Connect the input signal and output load as required for the channel to be calibrated. For dual output 633T units, you may calibrate the outputs one at a time, without affecting the opposite output.
2. Adjust the input signal to precisely 4.000mA DC (zero). Adjust the output zero pot until the output reads precisely 4.000 ± 0.008 mA DC.
3. Adjust the input signal to precisely 20.000mA DC (full-scale). Adjust the output span pot until the output reads precisely 20.000 ± 0.008 mA DC.
4. Repeat steps 2 & 3 until the readings converge.
5. As a check of calibration, adjust the input signal to precisely 12.000mA and verify the output measurement to within $\pm 0.05\%$ of span (± 0.008 mA DC). If the measurement error is greater than $\pm 0.05\%$ of output span, then you should repeat steps 2-4 again until acceptable accuracy is obtained.
6. Repeat steps 1-5 for the second channel of 632T units, or the second output of 633T units.

CALIBRATION

Note: Zero and span pots are turned clockwise to increase the output signal, and counter-clockwise to reduce the output signal.

TECHNICAL REFERENCE

- **Safety Agency Approvals** – CE, UL, & cUL listed, plus Class 1; Division 2; Groups A, B, C, and D approval.
- **Full Three-Way Galvanic Isolation** – Each input channel, each output channel, the excitation supply, and power are all isolated from each other for safety and increased noise immunity.
- **Built-In Excitation Supply** – Independently isolated dual output 22V/22mA excitation supply can be used to power one or two 2-wire transmitters. Excitation outputs are independently current-limited.
- **Low Input Burden** – Less than 1.5V drop for full-scale current (631/632T units). Less than 3V for 633T signal-splitter units.
- **Flexible AC or DC Power** – Select a 12-36V DC, or universal 90-250VAC/125VDC input powered unit. DC powered units are diode-coupled for use with redundant supplies, and/or battery back-up.
- **Wide 0 to 1000 Ohm Load Range** – Can drive 20mA into 1000Ω.
- **Current Limited Output** – Output is safely limited to 27mA.
- **No Load Trimming Required** – You do not have to recalibrate the output if the load resistance is varied.
- **Plug-In Terminal Blocks & DIN-Rail Mount** - Makes mounting, removal, and replacement easy.
- **Hardened For Harsh Environments** - For protection from RFI, EMI, ESD, EFT, & surges. Has low radiated emissions per CE requirements.
- **Wide Ambient Operation** – Reliable over a wide temperature range.
- **Zero & Span Trim Pots** – $\pm 4\%$, 15-turn trim adjustments for maintaining long term zero and span calibration and accuracy.

KEY FEATURES

HOW IT WORKS

These isolators isolate one or two DC current input signals according to the model number, and provide isolated DC current output signal(s) with adjustable zero and span trim. DC powered units employ a wide input switching regulator (isolated flyback) to power each output circuit and the input excitation supply. AC powered units employ a unique universal input switching circuit to power each output circuit and the excitation supply. A single isolated excitation supply is shared between both channels, but it has separate current-limited outputs.

The input circuit employs a unique current transfer circuit that isolates the signal without generating a large voltage drop. Each input is separately isolated. An isolated secondary is used to generate an input excitation supply with dual 24V outputs (23mA each), suitable for powering one or two 2-wire transmitters. Each excitation supply output is current limited to prevent any short at one channel from pulling down the internal power supply, or the opposite output. Note that if this supply is shared by both inputs of dual input units, the resulting circuit is isolated as a group, but not channel-to-channel.

The isolated current signal is modulated and passed through a high-side zero and span adjustment circuit that will add or subtract loop current as required to precisely set the output range. A 24V high-side voltage is used to drive this circuit which will source 20mA into a load resistance up to 1000Ω. All I/O terminations include filters and transient voltage suppression to minimize noise and protect the unit from damage due to transients.

Refer to the simplified schematic shown below to help gain a better understanding of the circuit.

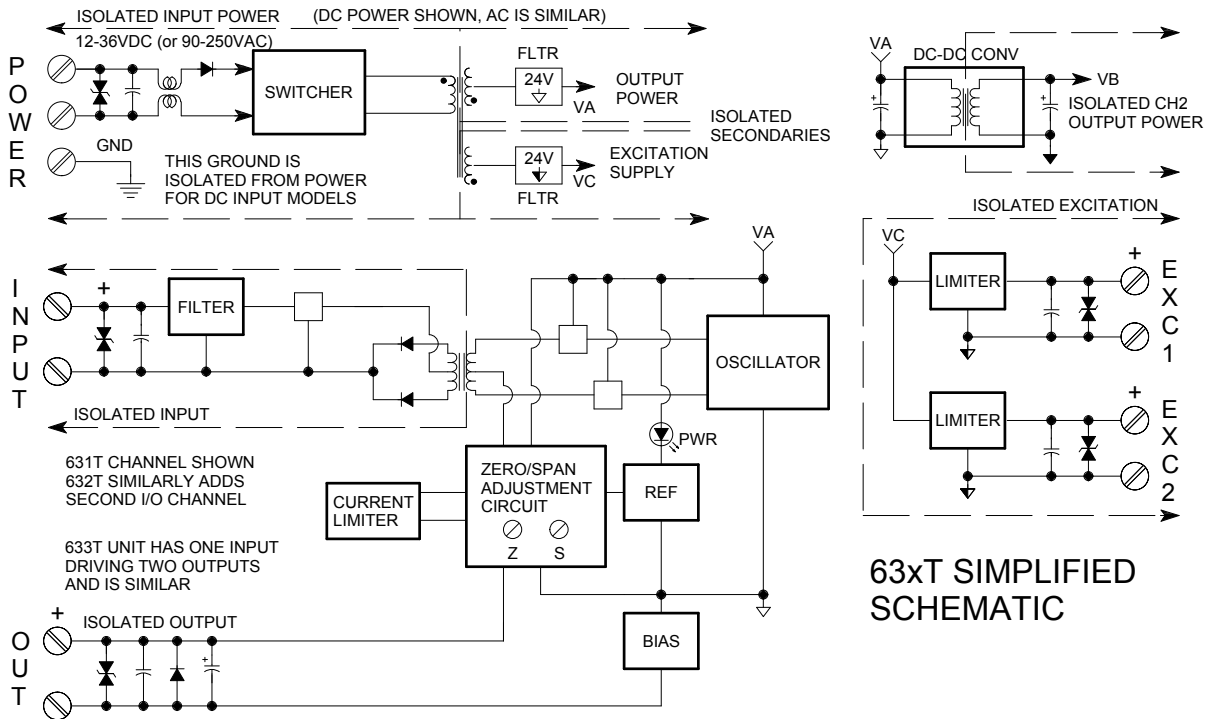

These models are DIN-rail mount, DC current input isolators for one or two input channels, and provide one or two isolated output channels with range trim adjustment. Units are DC-powered with reverse polarity protection, or universal AC-powered, and include an isolated input excitation supply with dual current-limited outputs. The inputs, outputs, excitation, and power circuits are isolated from each other.

The model prefix "63xT" denotes the Series 630 I/O Transmitter family. The "T" suffix denotes Transmitter. The four digit suffix of this model number represents the following options, respectively: "0" = Default; "1" or "5" = Universal AC/125VDC, or 12-36VDC Power, respectively; "00" = Default.

One or two input channels for DC current applications only. Input includes an isolated excitation power supply for powering 2-wire transmitters (see Connections Section for details).

DC Current: 4 to 20mA DC. **IMPORTANT:** Input current must not exceed 100mA or damage to the unit may occur. The input to 633T units is connected at input channel 2.

Input Forward Voltage Drop: Less than 1.5V (1.1V typical) at full-scale (631/632T), or 3V (2.3V typical) at full-scale (633T).

Input Overvoltage Protection: Bipolar Transient Voltage Suppressers (TVS), 5.6V working, 7.6V clamp level typical.

Input Reverse Polarity Protection: Diode included.

Input Response Time: For a step input, the output reaches 98% of calibrated span in less than 25ms, typical, with a 500Ω load.

Input Excitation: Isolated 22V DC minimum at 22mA, current limited near 23mA. See Excitation Supply specification below.

DC Current: 4 to 20mA DC.

Output Limiting: Output is limited to less than 28mA, nominal.

Output Load: 1000Ω minimum (631T); 950Ω minimum (632/633T); 1040Ω typical without excitation load.

Output Ripple: Less than ±0.1% of maximum output span.

Output Load Resistance Effect: Less than ±0.01% of output span effect for a ±100Ω change in load resistance.

Output Reverse Voltage Protection: Diode included.

Output Trim Range: Zero adjustment to 4mA ±4%, and span adjustment to 16mA ±4%.

May optionally power one or two 2-wire transmitters that may be driving the isolator input(s). Supply is fully isolated with two separate current-limited outputs at EXC1 & EXC2 (632T/633T). These outputs are common to each other and isolated (together) from the input, output, and power circuits.

Voltage: 27-22V range, each (22VDC at 22mA typical).

Current: Current is limited near 23mA, each. Note that EXC voltage will fold back if load attempts to draw current beyond limit current.

Ripple: 100mVp-p typical.

Reference Test Conditions: I/O=4 to 20mA; Load=500Ω; Ambient = 25°C; Power = 24VDC or 115VAC.

Accuracy: Accuracy is better than ±0.05% of output span, typical. This includes the effects of repeatability, hysteresis, terminal point linearity, and adjustment resolution, but does not include sensor error.

SPECIFICATIONS

Model Numbers

631T-0x00 (Single In/Out)
632T-0x00 (Dual In/Dual Out)
633T-0x00 (One In/Dual Out)

Input

Output

Excitation Supply

General

General

Temperature Drift: Better than $\pm 50\text{ppm}/^\circ\text{C}$ ($\pm 0.005\%/^\circ\text{C}$) over ambient range. Includes the combined effects of zero & span over temperature.
Bandwidth: -3dB at 50Hz, typical, with a 500 Ω load.
Noise Rejection (Normal Mode): -6dB @ 60Hz, typical, with 500 Ω load.
Noise Rejection (Common Mode): Better than 100dB at 60Hz, typical.

Enclosure & Physical

Dimensions: 1.05 inches wide, 4.68 inches tall, 4.35 inches deep. Refer to the dimensions drawing at the front of this manual.
DIN Rail Mount: Type EN50022; "T" rail (35mm).
I/O Connectors: Removable plug-in type terminal blocks rated for 15A/300V; AWG #12-24 stranded or solid copper wire.
Case Material: Self-extinguishing NYLON type 6.6 polyamide thermoplastic UL94 V-2, color beige; general purpose NEMA Type 1 enclosure.
Printed Circuit Boards: Military grade FR-4 epoxy glass.
Shipping Weight: 1 pound (0.45 Kg) packed.

Environmental

Operating Temperature: -25°C to +75°C (-13°F to +167°F), Temperature Code: T4. Dual channel 632/633T units only: If excitation supplies are used, maximum temperature is derated to +60°C (+140°F).
Storage Temperature: -40°C to +85°C (-40°F to +185°F).
Relative Humidity: 5 to 95%, non-condensing.
Isolation: Each input, each output, excitation supply, & power circuit are isolated from each other for common-mode voltages up to 250VAC, or 354V DC off DC ground, on a continuous basis (will withstand 1500VAC dielectric strength test for one minute without breakdown). Complies with test requirements of ANSI/ISA-82.01-1988 for voltage rating specified.
Installation Category: Designed to operate in an installation in a Pollution Degree 2 environment with an installation category (over-voltage category) II rating.

CAUTION: Risk of Electric Shock – More than one disconnect switch may be required to de-energize equipment before servicing.

CAUTION: Do not exceed 36VDC peak, to avoid damage to the module.

External Fuse (DC): Select a high surge tolerant fuse rated for 1A or less to protect unit.

CAUTION: Do not exceed 250Vrms, to avoid damage to the module.

External Fuse (AC): Select a time-lag fuse rated for 250VAC and 500mA to protect unit.

Power Requirements (AC or DC Powered Models): See tables for current. Data provided with full-scale output (each channel), and excitation at 20mA (each). If excitation supplies are not used, you can reduce power consumption up to 30% (AC), or 40% (DC).

DC-Powered Units: 12-36V DC SELV (Safety Extra Low Voltage)¹. Observe proper polarity.

Supply	631T-0500	632/633T-0500
12VDC ¹	165mA Typ/182mA Max	381mA Typ/419mA Max
15VDC ¹	129mA Typ/142mA Max	288mA Typ/317mA Max
24VDC	83mA Typ/91mA Max	163mA Typ/179mA Max
36VDC	61mA Typ/67mA Max	110mA Typ/121mA Max

AC-Powered Units: 90-250VAC¹ or 125VDC $\pm 10\%$.

Supply	631T-0100	632/633T-0100
125VDC	16mA Typ/18mA Max	30mA Typ/33mA Max
90VAC ¹	46mA Typ/51mA Max	82mA Typ/90mA Max
115VAC	38mA Typ/42mA Max	68mA Typ/75mA Max
230VAC	23mA Typ/25mA Max	37mA Typ/41mA Max
250VAC	22mA Typ/24mA Max	36mA Typ/40mA Max

¹**Note (Dual channel 632/633T models only):** The minimum supply voltage is raised to 15VDC or 100VAC if excitation supplies are used.

Electromagnetic Interference Immunity (EMI): Unit has demonstrated a measurement shift less than $\pm 0.25\%$ of output span with interference from switching solenoids, commutator motors, and drill motors.

Minimum Immunity Per European Norm EN50082-1:

Electrostatic Discharge (ESD) Immunity: 4KV direct contact and 8KV air-discharge to the enclosure port per EN61000-4-2.

Radiated Field Immunity (RFI): 10V/M, 80 to 1000MHz AM and 900MHz keyed carrier, per EN61000-4-3 and ENV50204.

Electrical Fast Transient Immunity (EFT): 2KV to power, and 1KV to signal I/O per EN61000-4-4.

Conducted RF Immunity (CRFI): 10Vrms, 150KHz to 80MHz, per EN61000-4-6.

Surge Immunity: 0.5KV per EN61000-4-5.

Emissions Per European Norm EN50081-1:

Radiated Frequency Emissions: 30 to 1000MHz per EN55022 Class B.

Electromagnetic Compatibility (EMC) -

Minimum Immunity Per European Norm EN50082-1:

Electrostatic Discharge (ESD) Immunity: 4KV direct contact and 8KV air-discharge to the enclosure port per EN61000-4-2.

Radiated Field Immunity (RFI): 10V/M, 80 to 1000MHz AM and 900MHz keyed carrier, per EN61000-4-3 and ENV50204.

Electrical Fast Transient Immunity (EFT): 2KV to power, and 1KV to signal I/O per EN61000-4-4.

IMPORTANT: Power, input, and output (I/O) wiring must be in accordance with Class I, Division 2 wiring methods of Article 501-4(b) of the National Electrical Code, NFPA 70 for installations in the US, or as specified in section 18-1J2 of the Canadian Electrical Code for installations within Canada and in accordance with the authority having jurisdiction.

This equipment is suitable for use in Class I, Division 2, Groups A, B, C, and D, or non-hazardous locations only.

WARNING – EXPLOSION HAZARD – Substitution of components may impair suitability for Class I, Division 2.

WARNING – EXPLOSION HAZARD – Do not disconnect equipment unless power has been switched off or the area is known to be non-hazardous.

Safety Approvals: CE marked (EMC Directive 89/336/EEC), UL Listed (UL508-17th Edition, ANSI/ISA 12.12.01, 2007 Edition), cUL Listed (Canada Standard C22.2, Nos.142-M1987 and 213-M1987), Hazardous Locations: Class I; Division 2; Groups A, B, C, D.

LED Indicators:

PWR (Green) – One per output channel. Constant ON if power is on.

Controls:

Zero Adjust – One per output. A 15-turn potentiometer for making output zero range adjustments to $4\text{mA} \pm 4\%$ (refer to Calibration).

Span Adjust - One per output. A 15-turn potentiometer for making output span range adjustments to $16\text{mA} \pm 4\%$ (refer to Calibration).

Environmental

These limits represent the minimum requirements of the standard, but product has typically been tested to comply with higher standards in some cases.

Agency Approvals

Controls & Indicators