

Innovative Technology Limited  ®

Intelligence in Validation

Secure Bank Note Handling Solutions Of The Future

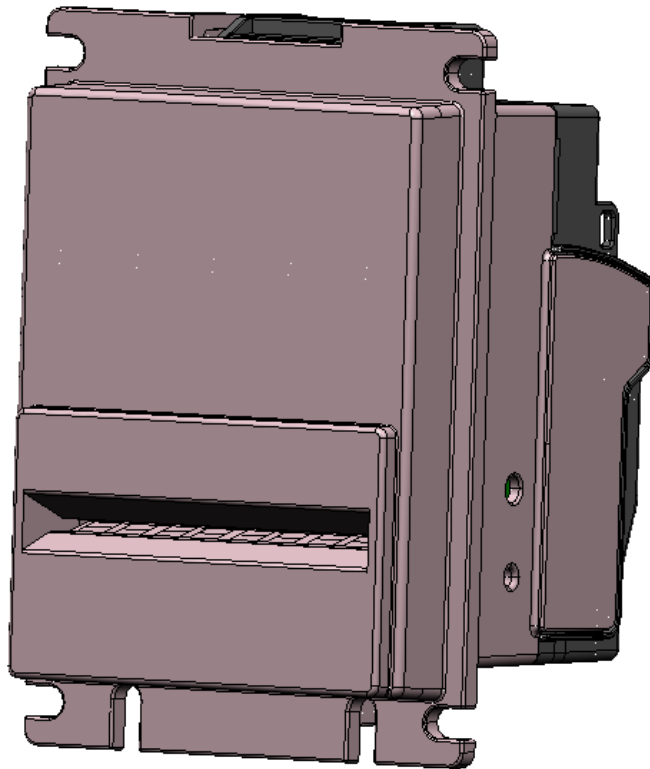

Operations Manual BV20-1

© Copyright Innovative Technology Limited 2007

CONTENTS

1.	INTRODUCTION	4
2.	SCOPE OF DOCUMENT	5
3.	ENVIRONMENT AND POWER REQUIREMENTS.....	6
4.	GENERAL DESCRIPTION	7
5.	MACHINE INTERFACE: HARDWARE.....	8
5.1	Interface Connector Pin Details	9
5.2	Configuration Button Functions.....	10
	BV20 Programming Mode	10
	Configuration Card Programming Mode	10
	Current Setting Indicator Mode	10
	Encryption Key Reset Function (CCTALK)	10
5.3	Additional Hardware Modules	11
6.	MACHINE INTERFACE: PROTOCOLS	13
6.1	Parallel Input and Output:	13
6.2	Pulse Stream Output.....	14
6.3	Binary Output – BIN	15
6.4	Serial Input/Output – SIO	16
6.5	Smiley® Secure Protocol - SSP.....	19
6.6	Multi-Drop Bus / Internal Communications Protocol (MDB/ICP).....	20
6.7	CCTalk Protocol – CCT.....	22
7.	USING BV20 CONFIGURATION CARDS.....	23
8.	MECHANICAL INSTALLATION.....	24
9.	ROUTINE MAINTENANCE	25
9.1	Re-Calibration	25
10.	SUPPORT TOOLS	26
10.1	Configuration Cards	26
10.2	ITL Bank Note Validator Currency Manager.....	26
10.3	Validator Programming System (DA3).....	26
10.4	Internet Website Support	27
10.5	E-mail Support	27
	Appendix A – Exploded Diagrams	28
	Appendix B – ESCROW Control	30
	Appendix C – Interface Tools DA1 – DA2.....	31
	Appendix D – Configuration Cards.....	33
	Appendix E – PC System Specification	39
	Appendix F – Low Power Mode	40

1. Introduction

This manual describes the operation of the BV20 Bank note Validator as fitted with Firmware Version 4.00 or greater.

CAUTIONS:

- **THIS PRODUCT MUST BE FITTED WITH A 2 AMP FUSE BEFORE USE.**
- **THE BV20 VALIDATOR IS PIN FOR PIN COMPATIBLE WITH NV7/8/9/10, BUT NOT PIN FOR PIN COMPATIBLE WITH THE NV2/3/4/4X OR 5 SERIES PRODUCTS.**

We recommend that you study this manual as there are many new features permitting new uses and more secure applications.

If you do not understand any part of this manual please contact the factory, contact details are below, for assistance. In this way we may continue to improve our product.

Innovative Technology Ltd.

Derker Street

Oldham

England

OL1 4EQ

Tel: +44 (0) 161 626 9999

Fax: +44 (0) 161 620 2090

E-mail: support@innovative-technology.co.uk

Web site: www.innovative-technology.co.uk

WARNING

ONLY SUITABLY TRAINED PERSONNEL SHOULD CARRY OUT ANY WORK ON THIS EQUIPMENT IN ACCORDANCE WITH ALL CURRENT LOCAL, NATIONAL AND INTERNATIONAL HEALTH AND SAFETY REGULATIONS.

Smiley® and the ITL Logo are international registered trademarks and they are the property of Innovative Technology Limited.

Innovative Technology has a number of European and International Patents and Patents Pending protecting this product. If you require further details please contact the factory.

Innovative Technology is not responsible for any loss, harm, or damage caused by the installation and use of this product. This does not affect your local statutory rights. If in doubt please contact Innovative Technology for details of any changes

2. Scope of Document

This document is intended for those who will:

1. Install the BV20 equipment.
2. Maintain the BV20 equipment.

Although information is included which will allow a degree of fault diagnosis and repair, it is recommended that for all but simple mechanical repairs, the unit must be returned to an approved service centre for repair.

CAUTIONS:

- **NEVER EXCEED THE RECOMMENDED ENVIRONMENTAL AND ELECTRICAL LIMITS.**
- **DO NOT ATTEMPT TO LUBRICATE THE MECHANISMS AS THIS MAY AFFECT THE NOTE TRANSPORT.**
- **DO NOT POLISH THE LENS AS THIS MAY ALTER THE OPTICAL CHARACTERISTICS.**
- **IF THE BV20 VALIDATOR IS DISASSEMBLED THE UNIT MUST BE RE-CALIBRATED AND RE INITIALISED, FOLLOWING RE-ASSEMBLY.**

Innovative Technology Ltd has a policy of continual product improvement. As a result the products supplied may vary from the specification described here.

3. Environment and Power Requirements

This section details the Environmental and Power requirements.

Environment	Minimum	Maximum
Temperature	+3°C	+50°C
Humidity	5%	95% Non condensing

Table 1 - Environmental Requirements

CAUTIONS:

- IF THE INPUT VOLTAGE FALLS BELOW 11V THE BV20 MAY NOT OPERATE CORRECTLY (WILL REJECT NOTES). THE FRONT BEZEL LIGHTS WILL FLASH TO INDICATE INCORRECT CONDITIONS
- IT IS RECOMMENDED THAT THE POWER SUPPLY USED CAN SUPPLY AT LEAST 1.7 AMPS.

Electrical Supply	Minimum	Maximum
Supply Voltage (V DC) Absolute Limits	+11V	+15V
MDB IF5 Version Supply Voltage	+18V	+48V DC or 34V AC
Supply Ripple Voltage	0	0.25V @100 Hz
Supply Currents:		
Sleep (Low Power Mode)		1.2mA
Standby		150mA
Validating		540mA
Peak (Motor Stall)		1700mA

Table 2 - Power Requirements

Interface Logic levels	Logic Low	Logic High
Inputs	0V To +0.5V	+3.7 V +12V
Outputs with 2K2Ω pull up	0.6V	Pull up voltage of host interface
Maximum Current Sink	50mA per output	

Table 3 - Interface Logic Levels

4. General Description

BV20 Validator - the next generation of ITL Bank Note Validators

The BV20 Bank Note System is a compact note-validating machine (see figure 1), suitable for most money machines. It will accept up to 16 different denominations of notes in the serial control mode.

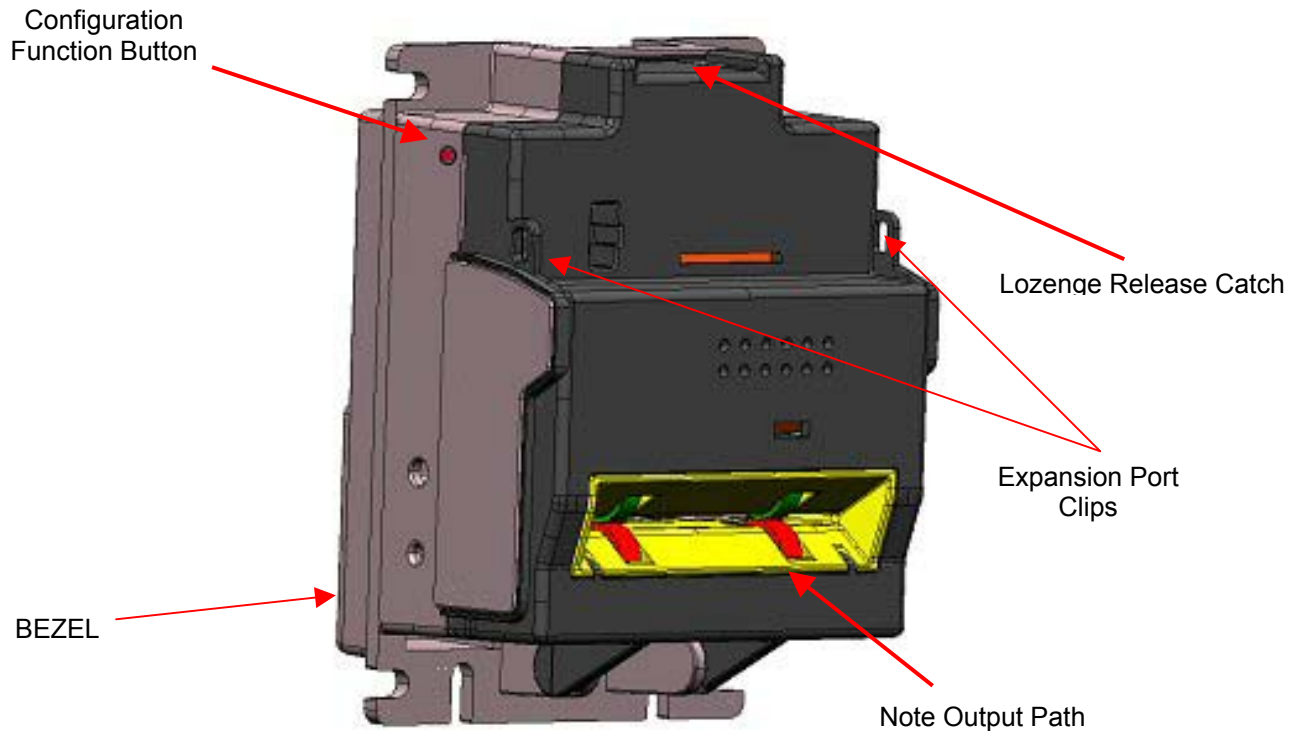

Figure 1 – The BV20 with Vertical Bezels

The BV20 Validator leaves the factory preset to at least one currency so that it is ready for immediate installation. If it is required to change the currency data set this may be done using the PC based Validator Management software.

New currencies and applications are being tested all the time, please refer to our web site or contact the factory for information concerning specific currencies if they are not already included on our approved list.

The BV20 is designed for easy installation in most machines.

Interfacing the Validator is very simple, with the choice of the following protocols:

SSP	PULSE	PARALLEL	BINARY
CCTALK	SIO	MDB	NIS
IF30	IF31	IF32	

Table 4 – Available Interfaces/Protocols

5. Machine Interface: Hardware

The BV20 interface connector is located on the left side of the unit; it has 16 pins (see figure 2) refer to Table 4 for the pin allocation. Two are used for the 0V and +12V power supply and there are five outputs and five inputs, the remaining four pins are reserved for factory use and should not be connected. An example mating connector is Molex type Part No: 39-51-2160.

It is possible to connect the BV20 to machines operating at 110 Volts or to machines operating at MDB voltages by means of additional Hardware modules. The modules are attached to the BV20 by means of the External hardware clips and connected to the 16-pin connector. (See section 5.3)

The BV20 also has a Configuration Button on the opposite side from the Connector (See Figure 3).

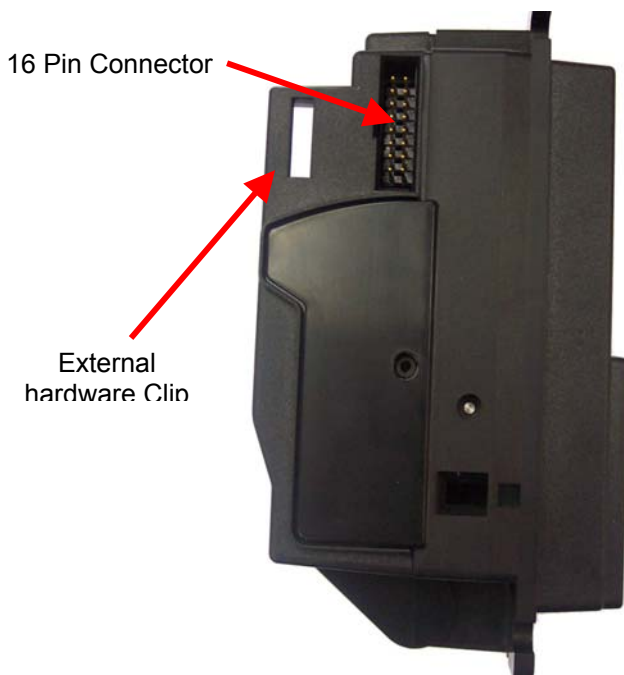

Figure 2 – Interface Connector



Figure 3 – Configuration Button

5.1 Interface Connector Pin Details

The connector pin details are described below (see table 5); they use an IDC 16-pin 0.1" pitch header with 2 rows of 8 pins.

Pin	Name	Description
1	Vend 1	Open Collector Output. Function changes depending on Machine Interface Protocol. (See individual interface descriptions for details) Also the Pulse Stream output Also the serial Output pin in SSP Serial Mode, and other serial modes
2	Vend 2	Open Collector Outputs. Function changes depending on Machine Interface Protocol. (See individual interface descriptions for details)
3	Vend 3	
4	Vend 4	
5	Inhibit 1	Inhibit channel 1 by holding this pin HIGH. To Enable a channel the inhibit must be held LOW Also the serial Input pin in SSP Serial Mode, and other serial modes
6	Inhibit 2	Inhibit channel 2 by holding this pin HIGH
7	Inhibit 3	Inhibit channel 3 by holding this pin HIGH
8	Inhibit 4	Inhibit channel 4 by holding this pin HIGH
9	Busy	BV20 is validating and stacking output. Active low while the BV20 is reading, transporting or stacking a note.
10	Escrow	Operate Escrow function by holding LOW (see Appendix B – ESCROW Control for full details)
11	Factory Use Only	Do Not Connect
12	Factory Use Only	Do Not Connect
13	Factory Use Only	Do Not Connect
14	Factory Use Only	Do Not Connect
15	+Vin	Nominal 12V DC supply
16	0V	0V Supply

Table 5 - 16 Pin Connector Details

5.2 Configuration Button Functions

The functions available via the Configuration Function Button are detailed in Table 6

Configuration Button	Power Status	Function
Press & Hold (> 1 sec)	Powered ON	Sets BV20 to Programming Mode (SSP)
Press Once	Powered ON	Enables Configuration Card Programming
Press Twice (Within Half a second)	Powered ON	Current Setting Indicator
Press & Hold	Powered OFF	Resets Cctalk key to Default setting

Table 6 – Configuration Button Functions

BV20 Programming Mode

Press and Hold the Configuration Button for at least 1 second whilst the BV20 is powered up. The Bezel LED will flash rapidly to indicate that SSP is being loaded. Once this process has finished the BV20 will reset. The BV20 will now be in Programming Mode (SSP) and allow connection to a PC via a DA1 or DA2 adapter or connection to a DA3.

Note: This mode can only be cancelled by re-programming with a Configuration Card or via the Validator Manager program. Please ensure you are aware of all the BV20 programmed settings before entering this mode. Failure to restore the original setting will stop the BV20 from operating in the Host machine.

Configuration Card Programming Mode

Press the Configuration Button once whilst the BV20 is powered up. If done correctly the Bezel LED will flash every 1-second. This will allow the insertion of a Configuration Card to change the Firmware Protocol in the BV20. (See Chapter 7- [Using BV20 Configuration Cards](#) for full details). This mode can be cancelled by again pressing the Configuration Button once.

Current Setting Indicator Mode

Press the Configuration Button twice within half a second whilst the BV20 is powered up. The BV20 Bezel LED will then perform a series of flashes to indicate the current settings within the validator. (See Program Check Procedure, page 2 in [Appendix D – Configuration Cards](#))

Encryption Key Reset Function (CCTALK)

Note: This function will only be possible if the BV20 is programmed to Cctalk mode. It is not possible to reset the key from SSP mode.

Press and hold the Configuration Button Whilst the BV20 powered is off. Apply the power and keep the button pressed for several seconds. The cctalk Encryption key will now be restored to the default setting.

5.3 Additional Hardware Modules

The BV20 currently supports the following additional hardware Modules for connection to machines with alternative power specifications.

- MDB Voltage Regulator Module.
- 110V Voltage Regulator Module.

The modules attach to the back of the BV20 and are held in place by the expansion port clips and a single fixing screw.

For unit and cable dimensions please see diagrams below.

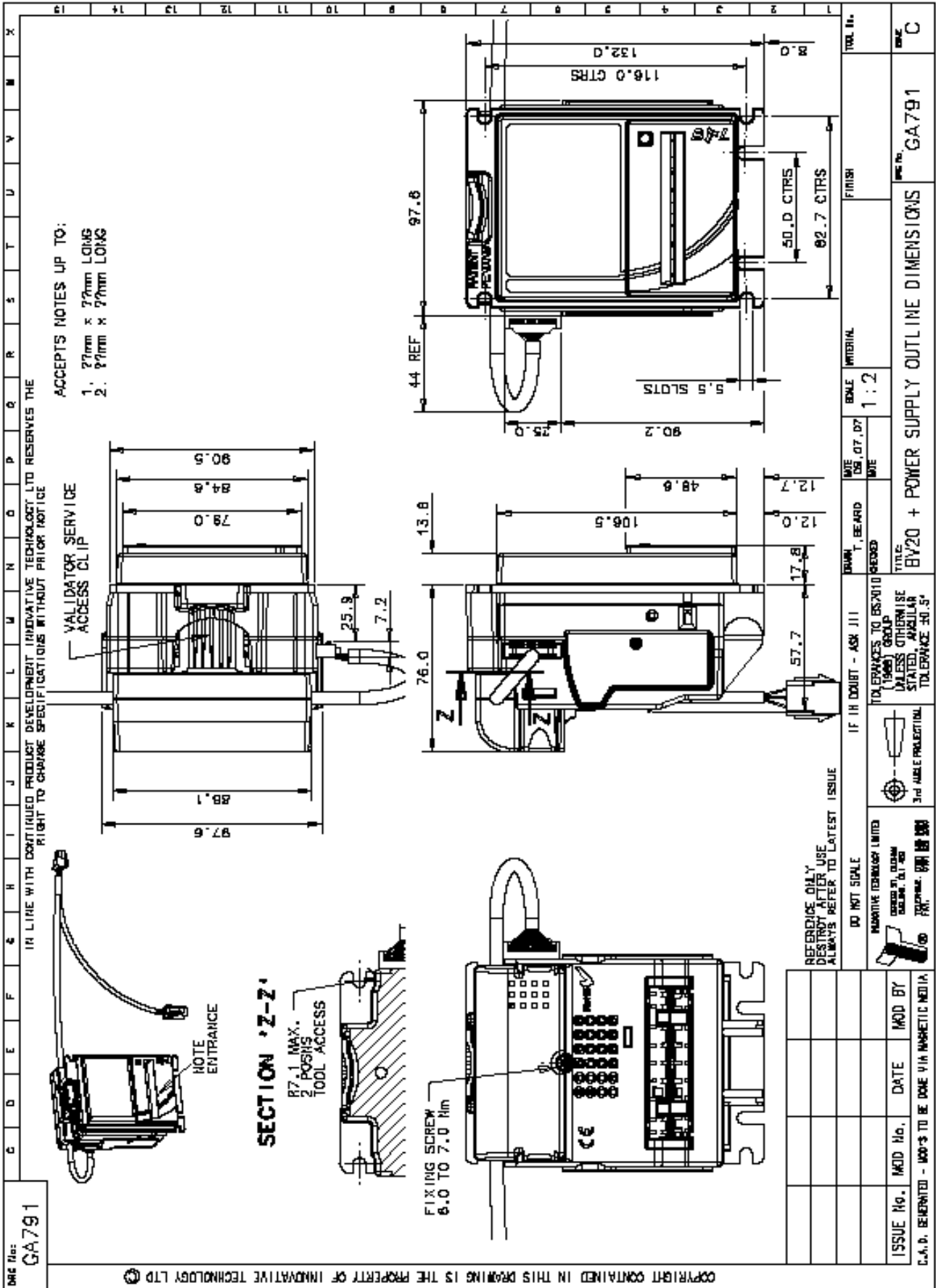

6. Machine Interface: Protocols

ITL strongly recommends the use of a Serial protocol (Preferably SSP) to achieve the highest security.

6.1 Parallel Input and Output:

To use Parallel Output for 4-note/channel acceptance the Parallel interface must be programmed into the validator via the Configuration Cards (See [Appendix D – Configuration Cards](#)) or via the ITL BNV Currency Manager program.

Vend Signals: (Pins 1 to 4). The four channels have their own individual outputs. If a note is recognised then the relevant Vend line is set low for a period of $100 \pm 3\text{ms}$. Pulses outside these limits should be rejected as a precaution against false triggering.

Busy Output: (Pin 9). This is a general-purpose busy signal. It is active low while the BV20 is in operation.

Escrow Control: (Pin 10) Hold this pin Low to enable the single note escrow function. (See [Appendix B – ESCROW Control](#)).

If the host machine aborts the transaction by setting the corresponding inhibit input high, the note is returned immediately.

The host machine can force the return of the note to the customer by setting the inhibit line high, at any time before the end of the 30 second time-out. Setting high all the inhibits causes a note reject.

In the event of a note being forcibly removed from the mouth of the BV20 during the 30-second interval, the BV20 will go out of service for 45 seconds.

Inhibit Operation: (Pins 5 – 8) Channel 1 to 4 have their own inhibit input to allow the host machine to refuse specified notes. To inhibit a channel, the relevant inhibit input must be held high. To enable a channel, the corresponding inhibit must be latched low so that notes may be accepted.

If all four inhibits are high simultaneously then the BV20 will be disabled. In this state the bezel LED will not illuminate and if a note is inserted the motor will run in reverse preventing the insertion of the note.

All four inhibits may be connected together to create a 'global' inhibit. In this way the BV20 may be brought in and out of operation by the host machine.

It is possible to operate the BV20 in Low power mode with the Parallel interface. For further details please see Appendix F – Low Power Mode

6.2 Pulse Stream Output

To use pulse stream output for acceptance of up to 16 note/channel acceptance, The Pulse interface must be programmed into the validator via the Configuration Cards (See [Appendix D – Configuration Cards](#)) or via the ITL BNV Currency Manager program.

Vend Signal: (Pins 1) When a note is recognised vend 1 will pulse a pre set number of times, the number of pulses can be set via the ITL BNV Currency Manager program (and set to default values with supplied dataset). The pulse width can be set either with the ITL BNV Currency Manager program or via the Configuration Cards (See [Appendix D – Configuration Cards](#))

Busy Output: (Pin 9). This is a general-purpose busy signal. It is active low while the BV20 is in operation.

Escrow Control: (Pin 10). No escrow function in this mode

Inhibit Operation: (Pins 5 – 8) Channels 1 to 4 have their own inhibit input to allow the host machine to refuse specified values of notes. To inhibit a channel, the relevant inhibit input must be held high. To enable a channel, the corresponding inhibit must be latched low so that notes may be accepted.

If all four inhibits are high simultaneously then the BV20 will be disabled. In this state the bezel will not illuminate and if a note is inserted the motor will run in reverse preventing the insertion of the note.

Note: Channels higher than four cannot be individually inhibited, but will be globally inhibited if inhibits 1 to 4 are inhibited.

It is possible to operate the BV20 in Low power mode with the Pulse interface. For further details please see Appendix F – Low Power Mode

Credit Hold Function:

If this function is enabled in pulse mode by Configuration card or ITL BNV Currency Manager program, the validator will take the note as normal but then wait until the escrow line is toggled low/high. It will then give out the number of pulses per dollar as set on the programming card. After the pulses have been given, the validator will then wait for another low/high toggle until the full value of credit pulses are given.

For example with a setting of 2 pulses per dollar, a five dollar bill will give 2 pulses, 5 times.

The busy line remains low throughout the whole process and the validator remains inhibited until all pulses are given.

6.3 Binary Output – BIN

To use Binary mode The Binary interface must be programmed into the validator via the Configuration Cards (See [Appendix D – Configuration Cards](#)) or via the ITL BNV Currency Manager program.

In the event that the machine needs more than 4 notes to be recognised, but the host machine cannot take advantage of the serial communication methods then the BV20 can be set to give a binary pattern output on the four parallel output pins.

If the BV20 is set to binary mode it will issue the vend signals as a binary pattern on the parallel outputs for $100 \pm 3\text{ms}$. In this way a maximum of 15 different notes can be accepted and 4 notes individually inhibited.

Vend Signals: (Pins 1 to 4). The four channels have their own individual outputs. If a note is recognised the binary representation of the channel number will be pulled low for $100 \pm 3\text{ms}$. Pulses outside these limits will be rejected as a precaution against false triggering due to noise.

Busy Output: (Pin 9). This is a general-purpose busy signal. It is active low while the BV20 is in operation.

Escrow Control: (pin 10). Hold this pin Low to enable the single note escrow function. (See [Appendix B – ESCROW Control](#)).

If the host machine aborts the transaction by setting the corresponding inhibit input high on pin 10, the note is returned immediately.

The host machine can force the return of the note to the customer by setting the inhibit line high, at any time before the end of the 30 second time-out. Setting all the inhibits high causes a note reject.

In the event of a note being forcibly removed from the mouth of the BV20 during the 30-second interval, the NV9 will go out of service for 45 seconds.

Inhibit Operation: (Pins 5 – 8) Channels 1 to 4 have their own individual inhibit input to allow the host machine to refuse specified values of notes. To inhibit a channel, the relevant inhibit input must be held high. To enable a channel the corresponding inhibit must be latched low so that notes may be accepted.

If all four inhibits are high simultaneously then the BV20 will be disabled. In this state the bezel will not illuminate and if a note is inserted the motor will run in reverse preventing the insertion of the note.

Note: Channels higher than four cannot be individually inhibited, but will be globally inhibited if inhibits 1 to 4 are inhibited.

It is possible to operate the BV20 in Low power mode with the Binary interface. For further details please see Appendix F – Low Power Mode

6.4 Serial Input/Output – SIO

Existing Smiley® NV4 -NV10 users may already be using the serial input/output facility in conjunction with the parallel inputs. The BV20 Validator also supports this system. However this interface is not recommended for new designs, the Smiley® Secure Protocol SSP interface is recommended.

CAUTION:

- **THE BV20 DOES NOT SUPPORT THE SIMPLE SERIAL DATA OUT ONLY MODE AS AVAILABLE ON NV4 AND EARLIER MODELS NV2 AND NV3. IT ONLY SUPPORTS THE SERIAL DATA INPUT/OUTPUT MODE.**
- **THE HOST MACHINE DOES NOT ECHO MESSAGES BACK TO THE VALIDATOR.**
- **THE BV20 DOES NOT OPERATE IN TRUE RS232 MODE. (ONLY TTL LEVEL).**

To use Serial Input/Output mode The SIO interface must be programmed into the validator via the Configuration Cards (See [Appendix D – Configuration Cards](#)) or via the ITL BNV Currency Manager program.

There are 4 different combinations of SIO available

SIO 300 Baud

SIO 300 Baud (Disabled at Start up) - A software enable must be sent to enable the validator.

SIO 9600 Baud

SIO 9600 Baud (Disabled at Start up) - A software enable must be sent to enable the validator.

The data is formatted as follows for 300 Baud

1-start bit - 8 data bits - 2 stop bits

Vend 1 (pin 1)

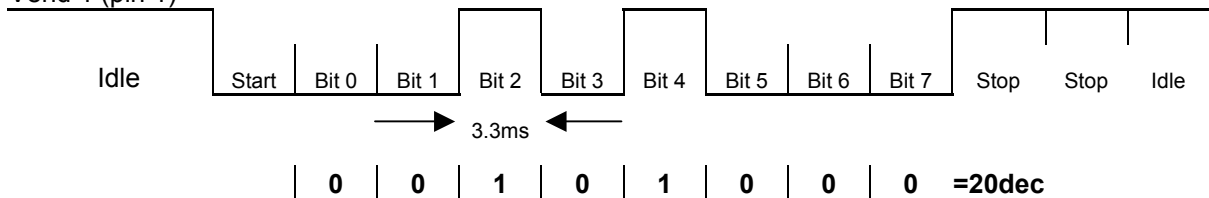

Figure- 4 Typical Serial Output: Transmission of the value 20 (decimal), Note not recognized

The data is formatted as follows for 9600 Baud

1-start bit - 8 data bits - 1-stop bits

Vend 1 (pin 1)

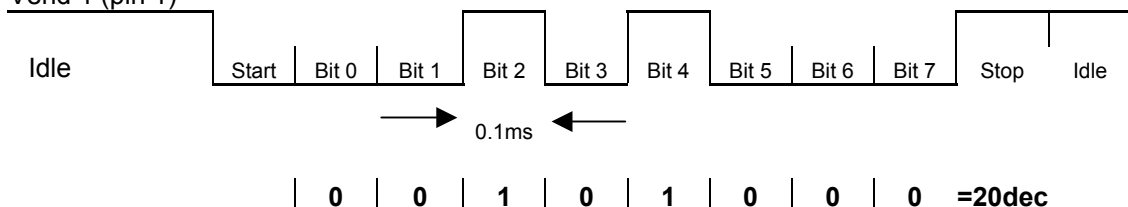

Figure- 5 Typical Serial Output: Transmission of the value 20 (decimal), Note not recognized

BV20-1 Operations Manual

The BV20 will receive and transmit the following event codes:

Recognised Receive Codes to BV20		Transmitted codes from BV20	
MESSAGE	DECIMAL VALUE	MESSAGE	DECIMAL VALUE
Inhibit C1	131	Note Accept on C1	1
Inhibit C2	132	Note Accept on C2	2
Inhibit C3	133	Note Accept on C3	3
Inhibit C4	134	Note Accept on C4	4
Inhibit C5	135	Note Accept on C5	5
Inhibit C6	136	Note Accept on C6	6
Inhibit C7	137	Note Accept on C7	7
Inhibit C8	138	Note Accept on C8	8
Inhibit C9	139	Note Accept on C9	9
Inhibit C10	140	Note Accept on C10	10
Inhibit C11	141	Note Accept on C11	11
Inhibit C12	142	Note Accept on C12	12
Inhibit C13	143	Note Accept on C13	13
Inhibit C14	144	Note Accept on C14	14
Inhibit C15	145	Note Accept on C15	15
Inhibit C16	146	Note Accept on C16	16
Un-inhibit C1	151	Note Not Recognised	20
Un-inhibit C2	152	Mechanism running slow	30
Un-inhibit C3	153	Strimming attempted	40
Un-inhibit C4	154	Channel 5 Note Rejected (fraud channel)	50
Un-inhibit C5	155	STACKER Full or Jammed	60
Un-inhibit C6	156	Abort During Escrow	70
Un-inhibit C7	157	Note may have been taken to clear jam	80
Un-inhibit C8	158	Validator Busy	120
Un-inhibit C9	159	Validator Not Busy	121
Un-inhibit C10	160	Command Error	255
Un-inhibit C11	161		
Un-inhibit C12	162		
Un-inhibit C13	163		
Un-inhibit C14	164		
Un-inhibit C15	165		
Un-inhibit C16	166		
Enable serial escrow mode	170		
Disable serial escrow mode	171		
Accept Escrow	172		
Reject Escrow	173		
Status	182		
Enable all	184		
Disable all	185		
Disable escrow timeout	190		
Enable escrow timeout	191		

Table 7 - Receive and Transmit Codes

BV20-1 Operations Manual

Example transactions are shown below (see table 8):

Event	Validator	Decimal Value	Host
Note entered into validator Note Accepted Channel 2	Validator Busy Validator Ready Accept on Channel 2	120 → 121 → 2 →	
Note entered into validators Note not recognised Validator has returned note	Validator Busy Validator Ready Note not recognised Validator Ready	120 → 121 → 20 → 121 →	
Software Inhibit Channel 4	Inhibit C4 Channel 4 Inhibited	← 134 134 →	Inhibit C4
Software Enable Channel 4	Uninhibit C4 Channel 4 Inhibited	← 154 154 →	Uninhibit C4
Status Report 3 byte status message	Status Requested Inhibit status Channels 1-8 Inhibit status Channels 9-16 Escrow On (=1) / Off (=0)	← 182 182 → Byte 1 → Byte 2 → Byte 3 →	Status Request
Turn on Escrow Mode	Escrow Mode Enabled	← 170 170 →	Enable Escrow Mode
Note accept in Escrow Mode Note entered into validator Note Accepted Channel 2	Validator Busy Validator Ready Accept on Channel 2 Accept Escrow Accept on Channel 2	120 → 121 → 2 → ← 172 172 → 2 →	Accept Note in Escrow

Table 8 - Example Protocols

6.5 Smiley® Secure Protocol - SSP

NOTE: Please refer to the Smiley® Secure Protocol (SSP) Specification (ITLDrawing GA138) on the web site for full details of the SSP protocol.

To use SSP mode The SSP interface must be programmed into the validator via the Configuration Cards (See [Appendix D – Configuration Cards](#)) or via the ITL BNV Currency Manager program, or by pressing and holding the Configuration Button for more than 1 second.

SSP is a secure serial interface specifically designed to address the problems experienced by cash handling systems in gaming machines. Problems such as acceptor swapping, reprogramming acceptors and line tapping are all addressed. This interface is recommended for all new designs.

The interface uses a master slave model, the host machine is the master and the peripherals (note acceptor, coin acceptor or coin hopper) are the slaves.

Data transfer is over a multi-drop bus using clock asynchronous serial transmission with simple open collector drivers. The integrity of data transfers is ensured through the use of 16 bit CRC checksums on all packets.

Each SSP device of a particular type has a unique serial number; this number is used to validate each device in the direction of credit transfer before transactions can take place.

Commands are currently provided for coin acceptors, note acceptors and coin hoppers. All current features of these devices are supported.

Features:

- Serial control of Note / Coin Validators and Hoppers
- 4 wire (Tx, Rx, +V, GND) system
- RS232 (TTL) - open collector driver
- High Speed 9600 Baud Rate
- 16 bit CRC error checking
- Data Transfer Mode

Benefits:

- Proven in the field
- Simple and low cost interfacing of transaction peripherals.
- High security control of payout peripherals.
- Defence against surrogate validator fraud.
- Straightforward integration into host machines.
- Remote programming of transaction peripherals
- Open standard for universal use.

For detailed information and full protocol specification please refer to SSP Interface Specification ITL (Drawing GA 138), this is available from the ITL website www.innovative-technology.co.uk.

To help in the software implementation of the SSP, ITL can provide DLL controls and Visual Basic applications on request. Please contact

6.6 Multi-Drop Bus / Internal Communications Protocol (MDB/ICP)

To use the MDB mode an IF5 interface box or must be fitted to the BV20 Validator. The MDB interface must be programmed into the validator via the Configuration Cards (See [Appendix D – Configuration Cards](#)) or via the ITL BNV Currency Manager program,

Note:

- **Please refer to the Multi-Drop Bus specification for the suggested current drive circuits available.**
- **The BV20 supports the MDB protocol version 1, level 1**
- **For detailed information and full protocol specification please refer to www.vending.org**

MDB defines a serial bus interface used in electrically controlled vending machines (see figure 6). This is a 9600 Baud Master-Slave system where the BV20 banknote validator is a slave to a master controller. A master has the capability of communicating with 32 peripherals or slaves. The master is defined as the Vending Machine Controller (VMC).

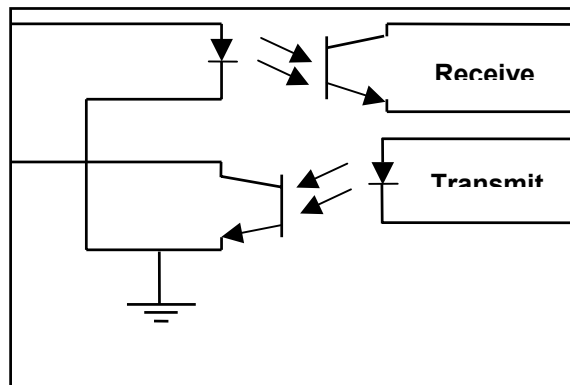

Figure 6 – MDB Opto Isolated Input / Output circuits BV20 MDB Slave

The BV20 banknote Validators have a unique address – 00110XXX binary (30H). The VMC polls the bus to detect presence of the BV20 Validator or get information on the current status of the Validator.

The Validators will respond when asked for activity with an acknowledgment, a negative acknowledgment or a specific reply, depending on its current status. Bus crashes are avoided as the Validators respond to being polled only by the VMC.

The international country code must be set for the country in which the Validators will be operating. This is either the international telephone code for that country, or the country code taken from ISO4217. The code is represented as two bytes. The initial digit signifies the source of the code. 0 signifies the telephone code is used, 1 signifies ISO4217 has been used.

For the USA the country code is 00 01, or 18 40

For Great Britain the code is 00 44, or 18 26.

The scaling factor must also be specified for each Validator. All accepted note values must be evenly divisible by this number.

- This number would be set to 100 (Hex 64) for the Euro or Great Britain.
- The number would be set to 1000 (Hex 03E8) for Columbia.
- The number of decimal places must also be programmed for each Validator
- The number would be set to 2 for Euro or USA
- The number would be set to 3 for Columbia

Adopting the numbers above:

- £5 would be displayed as 5.00
- £10 would be displayed as 10.00
- \$1 would be displayed as 1.00
- 1K Columbia would be displayed as 1.000

6.7 CCTalk Protocol – CCT

The BV20 supports the CCTalk serial protocol for easy interfacing with host machines that support this protocol.

To use CCTalk mode The CCT interface must be programmed into the validator via the Configuration Cards (See [Appendix D – Configuration Cards](#)) or via the ITL BNV Currency Manager program,

Pin out connections on BV20 for CCTalk are shown below (see figure 7) looking at the connection pins on the BV20 interface connector as defined in the CCTalk specification. It is recommended that all communications with the note validator must be encrypted using the encryption key, the default encryption key will be printed on the label of the BV20. To reset the Encryption key to it's default value see Chapter 5.2.

NOTE: For detailed information and full protocol specification please refer to www.CCTalk.org

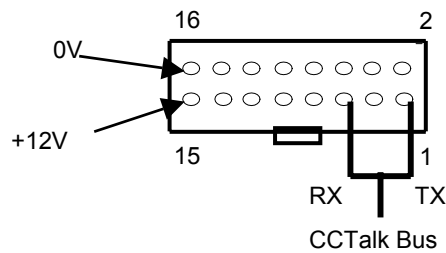

Figure 7 - CCTalk Connection Pins on the BV20

OTHER INTERFACES ARE AVAILABLE BY REQUEST FROM ITL

- NIS – Compatible with Mars Non-Isolated Serial Protocol
- IF30 – Compatible with ID003 protocol
- IF31 – Special interface (Columbia)
- IF32 – Compatible with Cash Code CCnet Protocol

7. Using BV20 Configuration Cards

The Configuration Cards offer the following functions:

- Select required Communication Interface (SSP, Cctalk, Parallel etc).
- Adjust the channel and pulse configuration on a pre-programmed BV20 to your own requirements.

Programming the BV20 with the configuration cards is enabled via the 'Configuration Button' on the right hand side of the BV20 (see Chapter 5.2 [Configuration Button Functions](#)). (For details on how to complete the configuration cards please see [Appendix D – Configuration Cards](#))

- 1) Press the Configuration button Once whilst the validator is powered up.
- 2) The Green bezel LED will now flash with a steady heartbeat until a Configuration Card is entered.
- 3) Once the Configuration Card has been entered the validator reads the card and immediately returns it.
- 4) The LED then flashes rapidly whilst the interface is being changed. If the LED flashes a number of times slowly, it is an indication of an error (For details of the Error Flash codes please see page 1 of [Appendix D – Configuration Cards](#))
- 5) When the changes are complete the validator resets.

If a configuration card is not entered, this function can be cancelled by pressing the button again Once.

It is now possible to check the programmed settings of the BV20 by pressing the Configuration button twice within half a second. (For details see page 2 of [Appendix D – Configuration Cards](#))

8. Mechanical Installation

The BV20 validator is available with either a 66mm or 72mm Bezel

ENG No: **GA790**

IN LINE WITH CONTIGUOUS PRODUCT DEVELOPMENT INNOVATIVE TECHNOLOGY LTD RESERVES THE RIGHT TO CHANGE SPECIFICATIONS WITHOUT PRIOR NOTICE

ACCEPTS NOTES UP TO:

- 56mm x 160mm LDMG
- 72mm x 160mm LDMG

SUPPLY AND POWER CONSUMPTION:

VOLTAGE : 11.0-13.5V
 RIPPLE : 0.25V AT 100MHz
 SLEEP : 1.2mA
 STANDBY : 150mA
 VALIDATING : 540mA
 PEAK : 1700mA

ENVIRONMENTAL OPERATING RANGE:

+3°C TO 50°C AT 5% TO 85% RH
 (NON CONDENSING)

UNLADEN WEIGHT : 0.3KG



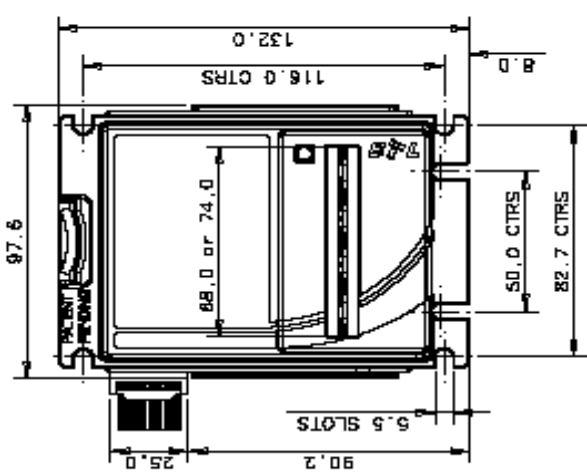

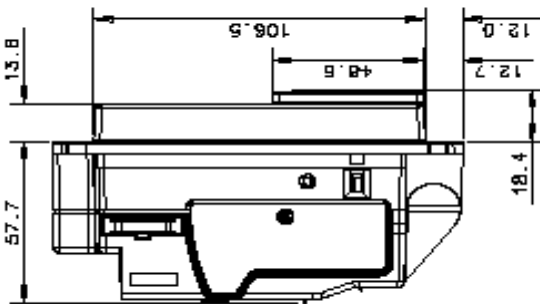

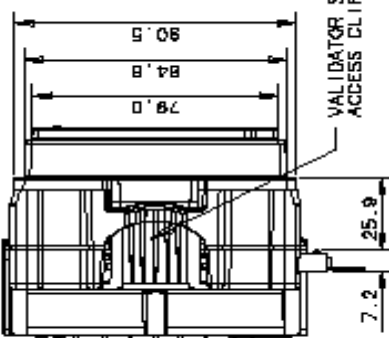

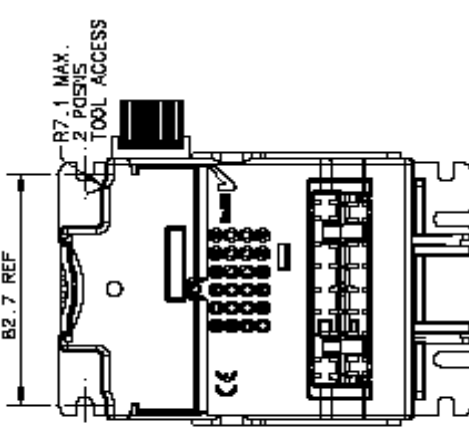

REFERENCE ONLY
 DESTROY AFTER USE
 ALWAYS REFER TO LATEST ISSUE

DO NOT SCALE

INNOVATIVE TECHNOLOGY LIMITED
 10001 7th Floor
 225 Raffles Place
 Singapore 048503

IF IN DEBET - ASK !!!
 (US\$) CHASIP
 UNLESS OTHERWISE
 STATED, ANGULAR
 TOLERANCE IS ±0.5°

DATE	BY	REVISION	DESCRIPTION

ISSUE No.	MCD No.	DATE	MCD BY
C.A.U. GENERATED - MCD'S TO BE DONE VIA MAGNETIC MEDIA			

TITLE: BV20 OUTLINE DIMENSIONS	SCALE: 1:2	DATE: 05.07.07	FINISH:

ISSUE No. **GA790**

COPYRIGHT CONTAINED IN THIS DRAWING IS THE PROPERTY OF INNOVATIVE TECHNOLOGY LTD ©

9. Routine Maintenance

The BV20 Validator has been designed to minimise any performance variation over time. Much of this is achieved by careful Hardware and Software design.

However, depending upon the environment in which it is used the BV20 may at some time require re-calibration.

9.1 Re-Calibration

The BV20 has an in-built self-calibration system that maintains the optical sensors at their best operating point. However if the BV20 is disassembled for any reason it will need to be re-calibrated. Re-calibration may only be performed under license from ITL, contact support@innovative-technology.co.uk for further details.

This can be performed in conjunction with the diagnostics software option in the ITL BNV Currency Manager Program and help menus supplied with this program.

10. Support Tools

The following support tools are available for use with the BV20 Bank Note Validator:

- ITL Bank Note Validator Currency Manager Software.
- Configuration Cards.
- Validator Programming System (DA3)
- Downloads from the Innovative Technology Ltd website: www.innovative-technology.co.uk
- E-mail Support via support@innovative-technology.co.uk

10.1 Configuration Cards.

For full details of the use and function of the Configuration Cards please see [Appendix D – Configuration Cards](#)

10.2 ITL Bank Note Validator Currency Manager

NOTE: The Validator must be set to Programming Mode (SSP) when connected to a computer or DA3 and then returned to the original Settings when complete (See Chapter 5.2 [Error! Reference source not found.](#)).

ITL BNV Currency Manager 3.2.0 or Higher must be used to access the BV20 functions

The ITL BNV Currency Manager software offers the following functions:

- Program the Validator by downloading pre-prepared currency data via the DA1 or DA2 kit.
- Check the firmware version and currency set already loaded on a BV20 unit.
- Adjust the channel and pulse configuration on a pre-programmed BV20 to your own requirements.
- Download a new version of firmware onto the BV20.
- Use diagnostic functions to check Validators operation

The software will run on an IBM compatible Personal Computer with Pentium™ processor or equivalent (see [Appendix E – PC System Specification](#) for operating system requirements) and requires a DA1 kit fitted to the serial port or DA2 kit fitted to the USB port. (See [Appendix C – Interface Tools DA1 – DA2](#))

10.3 Validator Programming System (DA3)

The DA3 is a programming system designed to enable the programming of ITL Bank Note Validators in the field without the use of a PC.

Once the DA3 has been programmed the user can:

- Update the existing software within a validator to the latest versions using the BNV Match Download function.
- Test the functionality of the validator away from the Host machine.

For full DA3 operation and functionality details please refer to the DA3 User Manual (Document number GA339)

Note: The BNV Overwrite download function is not available for the BV20 due to the Firmware/Dataset file structure

10.4 Internet Website Support

The Innovative Technology Ltd website provides the means to download new and updated currency sets and new versions of firmware for the BV20. You can obtain these along with technical bulletins by visiting www.innovative-technology.co.uk

10.5 E-mail Support

If the data you require is not available over the Internet Innovative Technology supports an e-mail system to help customers with unusual requirements. The address is: support@innovative-technology.co.uk

Appendix A – Exploded Diagrams

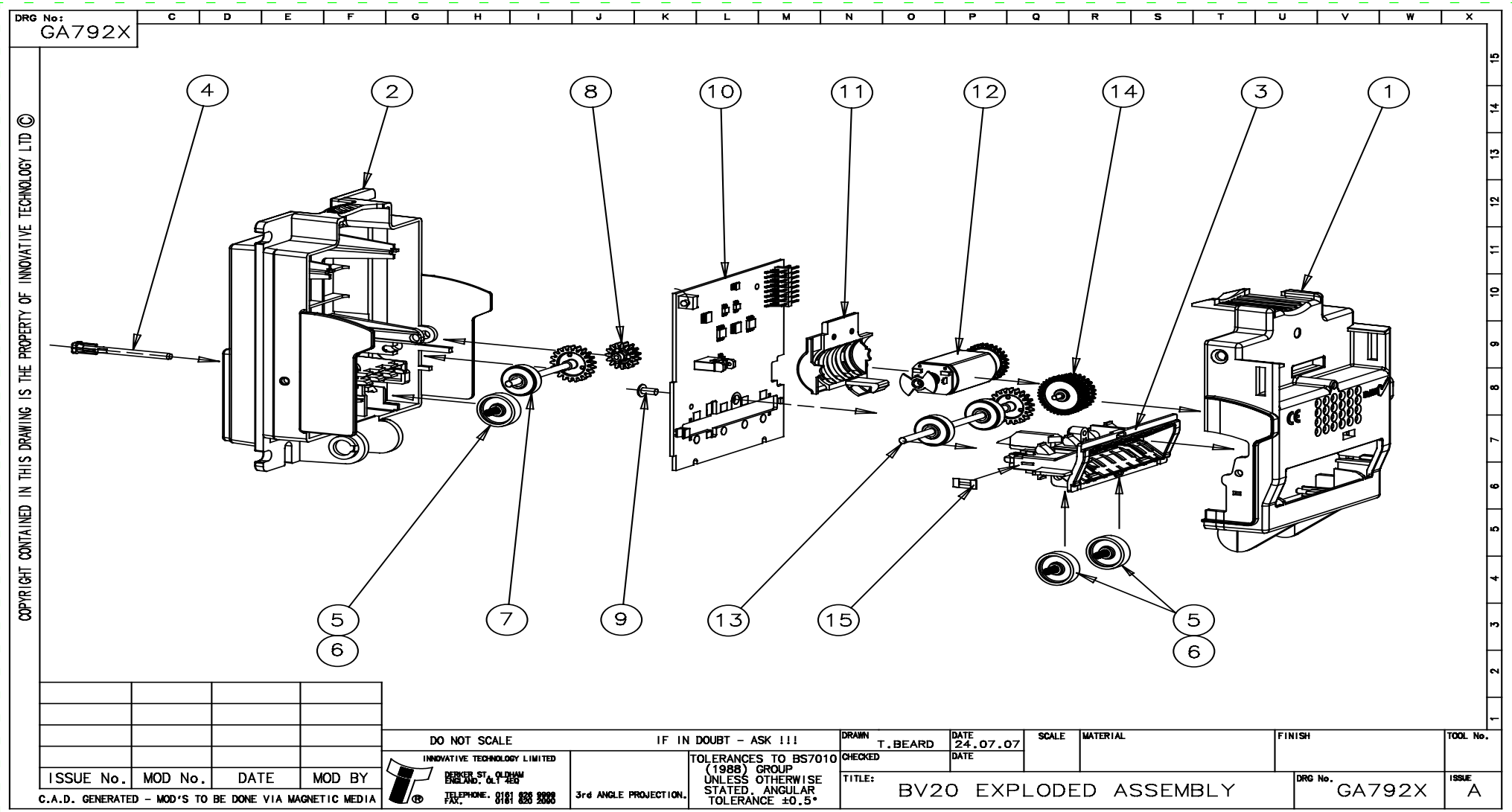

Exploded Diagram Parts List

N0	Part No	Part Description	Qty
1	PM771	BV20 Case	1
2	PM770	Bezel 72mm	1
2	PM781	Bezel 66mm	1
3	PA775		1
3	PA776		1
3	PM778	Lens Wide 72mm	1
3	PM782	Lens Narrow 66mm	1
4	PM787	Light Pipe	1
5	PM775	Pressure Wheel	3
6	SP162	Axle Spring	3
7	PA771		1
8	PM774	Idle gear (16T – 0.8M)	1
9	SC113	No.4 20x1/4" Pozi Flange BZP	1
10	PB243	Printed Circuit Board	1
11	PM773	Motor Cover	1
12	PA774	Motor Assembly	1
13	PA773		1
14	GA777		1
15	LB155	Strim Sensor Label	1

Appendix B – ESCROW Control

The BV20 has a single note escrow facility (pin 10) used in Parallel and Binary modes. This allows the Validator to hold onto the note once accepted, and then only stack the note in the cash box when the host machine confirms that the Vend operation has been completed. If no confirmation of the Vend is received then the note will be returned to the customer after 30 seconds, (see figure 8).

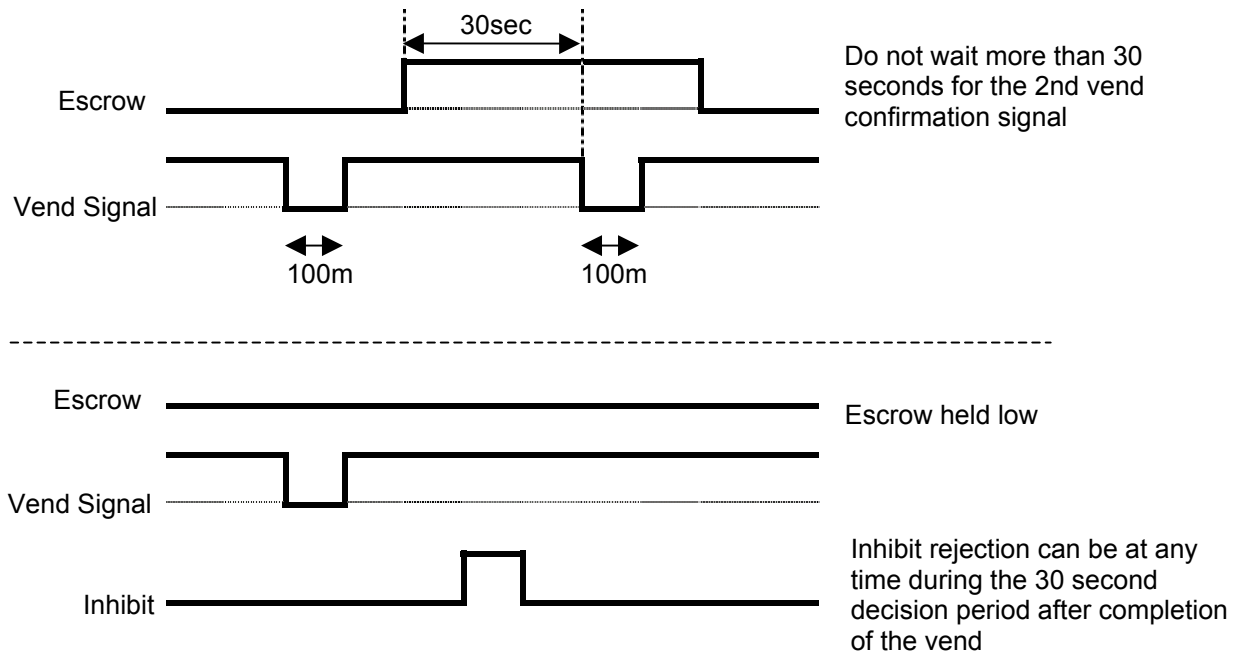

Figure 8 - Escrow Timing Diagram for Parallel Vends

If the host machine itself aborts the transaction by setting the corresponding inhibit input high, the note is returned immediately. The sequence of operations is as follows:

- Pin 10 held low awaiting note insertion.
- Note inserted. Validator issues a 100ms pulse on the appropriate channel.
- The host machine initiates vend process.
- The host machine sets pin 10 high to indicate that it wants the note. If this is not done within 30 seconds the Validator will return the note.
- The Validator issues a 100ms pulse on the appropriate channel after pin 10 going high to indicate final acceptance of the note. If the signal has not been received within 30 seconds it indicates the customer has forcibly retrieved the note and the vend will be aborted.
- The vend process is completed.
- The host machine sets pin 10 low in expectation of the next vend.

The host machine can force the return of the note to the customer by setting the inhibit line high, at any time before the end of the 30 second time-out. For channels above 4, setting all the inhibits high will cause a note reject.

In the event of a note being forcibly removed from the mouth of the BV20 during the 30-second interval, the BV20 will go out of service for 45 seconds.

Appendix C – Interface Tools DA1 – DA2

The DA1/2 Kits are designed for the following:

- Connecting of ITL Note Validators to a PC for the upgrade and user option setting of Currency and Firmware files.
- Testing note acceptance of Note Validators independent of the host machine to confirm that the validator is working.

The DA1 and DA2 Kits comprise the following components:

DA1	DA2
DA1 adapter board	DA2 adapter board
DA1 to NV7-10 and BV cable	USB type-A to Type-B cable
DA1 to NV4 Cable	DA2 to NV7-10 and BV cable
Power Cable	Power Cable
ITL Support CD-ROM	ITL Support CD-ROM

Connecting a DA1 to a validator and PC

For the PC system specification and set up refer to [Appendix E – PC System Specification](#).

Connect the DA1 to the validator as shown below (see figure 9), using the 16-way to 5-way connector. The supplied 3.5mm jack plug and 2 banana plugs are used to supply power to the DA1 when using a variable Bench power supply (Connect the +12 volts to the red banana plug and GND (0V) to the black plug). Alternatively a Portable DC Power Adapter supplying 12v and 1.5A minimum can be used.

Plug the 9-way D-type connector into the serial port of the PC and note of the number of the port, as this will be needed later for configuring the software. Once the connections have been made install the appropriate software for the validator you are using.

NOTE: The Validator must be in Programming mode when connected to a computer and then returned to the Original Settings when the download is complete

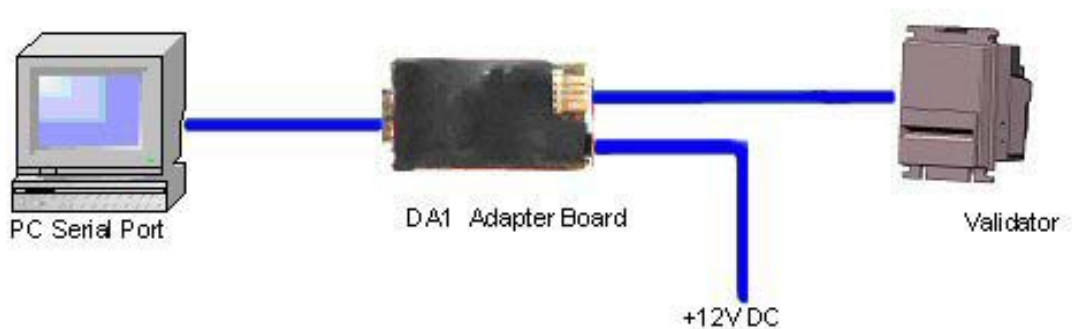

Figure 9 – Connecting DA1 to BV20 and PC for upgrading Validator programs

Connecting a DA2 to a validator and PC

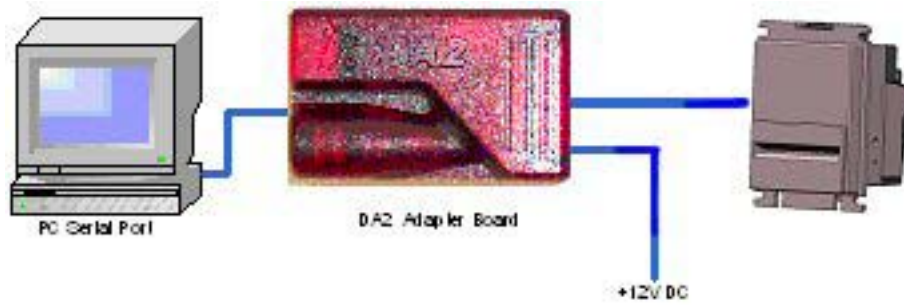

Figure 10 – Connecting DA2 to a BV20 and PC for upgrading Validator Programs

Software Installation

DA1 - To install the ITL BNV Download Manager Software insert the CDROM into the correct PC drive. The CD should automatically run and an installation menu will appear. Double click the ITL BNV Download Manager and follow the on-screen instructions. You can also install the Currency files, Firmware files and the Technical Manuals for each specific product as well as other generic documentation.

The Quick Start Guide for the DA1 is Document number GA151.

DA2 - To install the ITL BNV Download Manager Software insert the CDROM into the correct PC drive. The CD should automatically run and an installation menu will appear. Double click DA2 installation guide (GA338) and follow the instructions relating to your specific Operating System.

NOTE: All files contained on the CD are available from the ITL Website:

<http://www.innovative-technology.co.uk>

Please contact support@innovative-technology.co.uk, if you require further assistance.

Appendix D – Configuration Cards

GA 713 BV Configuration Option Programming

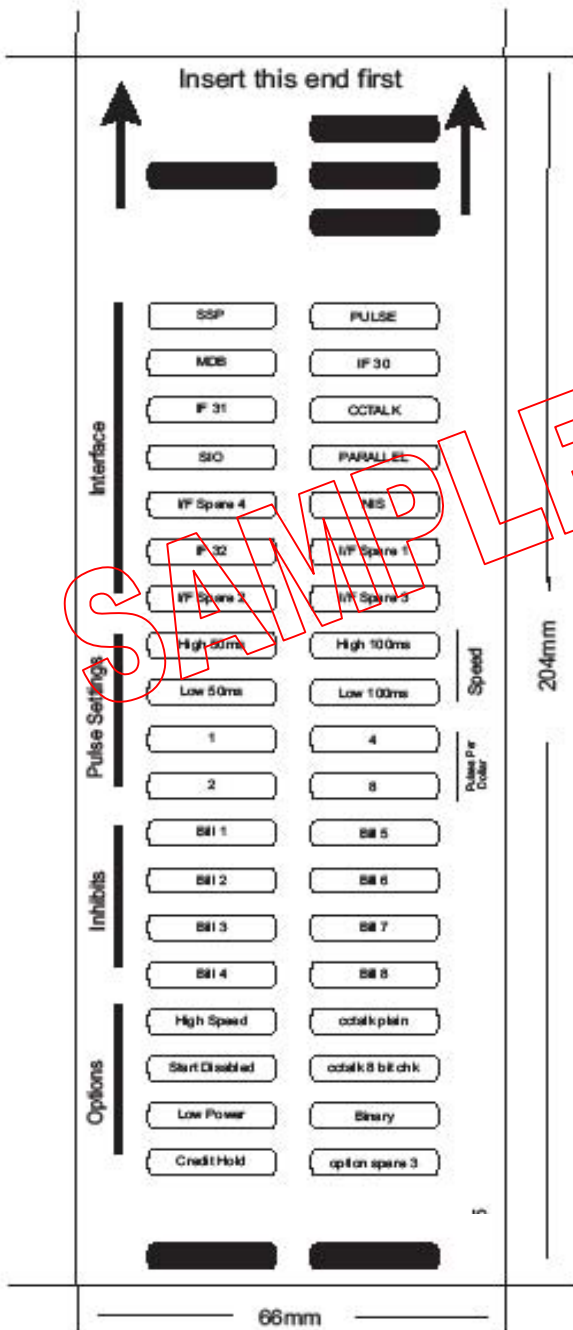

Instructions for use

1 - Cut card around outline - check measurements as printed. Check print options 'Page scaling' is set to 'None' when printing a pdf file to ensure correct size.

2 - Fill in sections as required. Take care to fill in the sections correctly, keep inside the lines and fill boxes fully as example below:

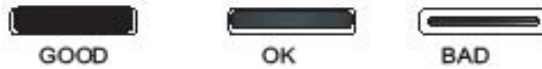

3 - Power-up BV and allow to reset.

4 - Click 'Function' button on BV to access Configuration Mode, BV bezel LEDs should be flashing at 1 second interval.

5 - Enter card into BV in direction indicated by arrows.

6 - Card will be rejected and if configuration was good the, bezel LEDs will flash at a fast rate while programming takes place. TAKE CARE TO ENSURE THE POWER IS NOT REMOVED AT THIS STAGE, THE BV MAY SUFFER PERMANENT DAMAGE !! The BV will then reset

7 - If an error has occurred, the card will be rejected and the bezel LEDs will flash slowly a number of times to indicate the error cause. (See table below for codes).

8 - IMPORTANT - CHECK THAT THE CONFIGURATION REQUESTED HAS BEEN SET IN THE BV BEFORE USE!

Flash	Error
2	Invalid card read - card entered wrong way round, card mis-read or card wrong version.
3	No interface selection was detected on card.
4	Multiple interface selection detected.
5	Invalid interface selected - the selected interface is not available for this BV.
6	Selected interface not compatible with BV version.
7	Pulse configuration error. Selected pulse options invalid.(e.g. multiple pulse per dollar)
8	ccTalk configuration error. Selected cctalk options invalid. (cctalk 8 bit chk not allowed without ccTalk Plain.)
9	Low power mode not available on this BV version.

GA713-1-5

Program Check Procedure

To check settings on a programmed unit:

- 1 - Power on unit.
- 2 - Click program set button on unit twice (like double click on mouse).
- 3 - Monitor bezel led and check flash codes on table below

	Flash count	Pulse High	Pulse Low	Pulse per dollar	High speed	Disabled	cctalk plain	cctalk 8 bit	low power	binary
SSP	1									
Pulse	2	ms/10	ms/10	value						
MDB	3									
IF 30	4									
IF 31	5									
cctalk	6						1 flash	2 flashes		
SIO	7				1 flash	2 flashes				
Parallel	8									1 flash
spare	9									
NIS	10									
IF 32	11				1 flash					
spare	12									
spare	13									
spare	14									

For example:

A pulse interface with 50ms high, 100ms low, 2 pulse per dollar will flash as follows 2,5,10,2

A SSP interface will only ever flash once

A cctalk interface with 16 bit checksum, no encryption wil flash 6,1

A cctalk interface with 8 bit checksum, no encryption wil flash 6,1,2

A Binary interface will flash 8,1

BV20-1 Operations Manual

Below are some typical examples of completed Configuration Cards.

Note: These Configuration Cards are samples and should not be copied for programming use. Please see document GA713-4 for useable cards.

Insert this end first

Interface	Pulse Settings	Inhibits	Options
PULSE MDB IF 30 IF 31 CCTALK SIO PARALLEL I/F Spare 4 NIS IF 32 I/F Spare 1 I/F Spare 2 I/F Spare 3	High 50ms High 100ms Low 50ms Low 100ms 1 4 2 8 PPMs Per Dollar	Bill 1 Bill 5 Bill 2 Bill 6 Bill 3 Bill 7 Bill 4 Bill 8	High Speed cctalk plain Start Disabled cctalk 8 bit chk Low Power Binary option spare 2 option spare 3

SSP

Interface	Pulse Settings	Inhibits	Options
SSP PULSE MDB IF 30 IF 31 CCTALK SIO I/F Spare 4 NIS IF 32 I/F Spare 1 I/F Spare 2 I/F Spare 3	High 50ms High 100ms Low 50ms Low 100ms 1 4 2 8 PPMs Per Dollar	Bill 1 Bill 5 Bill 2 Bill 6 Bill 3 Bill 7 Bill 4 Bill 8	High Speed cctalk plain Start Disabled cctalk 8 bit chk Low Power Binary option spare 2 option spare 3

Parallel

Interface	Pulse Settings	Inhibits	Options
SSP PULSE MDB IF 30 IF 31 CCTALK SIO I/F Spare 4 NIS IF 32 I/F Spare 1 I/F Spare 2 I/F Spare 3	High 50ms High 100ms Low 50ms Low 100ms 1 4 2 8 PPMs Per Dollar	Bill 1 Bill 5 Bill 2 Bill 6 Bill 3 Bill 7 Bill 4 Bill 8	High Speed cctalk plain Start Disabled cctalk 8 bit chk Low Power option spare 2 option spare 3

Binary

Insert this end first

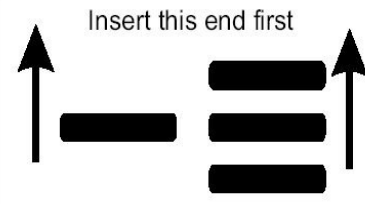

Interface

SSP	PULSE
MDB	IF 30
IF 31	<input type="checkbox"/>
SIO	PARALLEL
I/F Spare 4	NIS
IF 32	I/F Spare 1
I/F Spare 2	I/F Spare 3

Pulse Settings

High 50ms	High 100ms	Speed
Low 50ms	Low 100ms	
1	4	Pulses Per Dollar
2	8	

Inhibits

Bill 1	Bill 5
Bill 2	Bill 6
Bill 3	Bill 7
Bill 4	Bill 8

Options

High Speed	cctalk plain
Start Disabled	cctalk 8 bit chk
Low Power	Binary
option spare 2	option spare 3

Encrypted Cctalk

Insert this end first

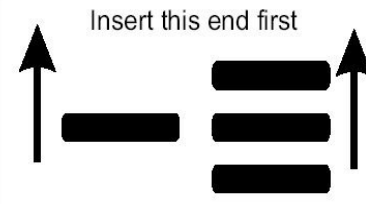

Interface

SSP	PULSE
MDB	IF 30
IF 31	<input type="checkbox"/>
SIO	PARALLEL
I/F Spare 4	NIS
IF 32	I/F Spare 1
I/F Spare 2	I/F Spare 3

Pulse Settings

High 50ms	High 100ms	Speed
Low 50ms	Low 100ms	
1	4	Pulses Per Dollar
2	8	

Inhibits

Bill 1	Bill 5
Bill 2	Bill 6
Bill 3	Bill 7
Bill 4	Bill 8

Options

High Speed	<input type="checkbox"/>
Start Disabled	cctalk 8 bit chk
Low Power	Binary
option spare 2	option spare 3

Unencrypted Cctalk with 16-bit Checksum

Insert this end first

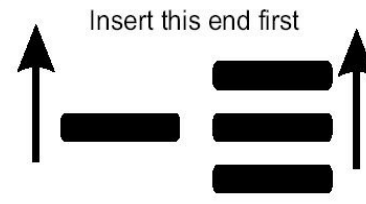

Interface

SSP	PULSE
MDB	IF 30
IF 31	<input type="checkbox"/>
SIO	PARALLEL
I/F Spare 4	NIS
IF 32	I/F Spare 1
I/F Spare 2	I/F Spare 3

Pulse Settings

High 50ms	High 100ms	Speed
Low 50ms	Low 100ms	
1	4	Pulses Per Dollar
2	8	

Inhibits

Bill 1	Bill 5
Bill 2	Bill 6
Bill 3	Bill 7
Bill 4	Bill 8

Options

High Speed	<input type="checkbox"/>
Start Disabled	<input type="checkbox"/>
Low Power	Binary
option spare 2	option spare 3

Unencrypted Cctalk with 8-bit Checksum

Insert this end first

Interface

SSP	
MDB	IF 30
IF 31	CCTALK
SIO	PARALLEL
I/F Spare 4	NIS
IF 32	I/F Spare 1
I/F Spare 2	I/F Spare 3

Pulse Settings

	High 100ms
	Low 100ms
	4
2	8

Inhibits

Bill 1	Bill 5
Bill 2	Bill 6
Bill 3	Bill 7
Bill 4	Bill 8

Options

High Speed	cctalk plain
Start Disabled	cctalk 8 bit chk
Low Power	Binary
option spare 2	option spare 3

Pulses Per Dollar

Insert this end first

Interface

SSP	
MDB	IF 30
IF 31	CCTALK
SIO	PARALLEL
I/F Spare 4	NIS
IF 32	I/F Spare 1
I/F Spare 2	I/F Spare 3

Pulse Settings

	High 100ms
	Low 50ms
1	4
2	8

Inhibits

Bill 1	Bill 5
Bill 2	Bill 6
Bill 3	Bill 7
Bill 4	Bill 8

Options

High Speed	cctalk plain
Start Disabled	cctalk 8 bit chk
Low Power	Binary
option spare 2	option spare 3

Pulses Per Dollar

Insert this end first

Interface

SSP	PULSE
	IF 30
IF 31	CCTALK
SIO	PARALLEL
I/F Spare 4	NIS
IF 32	I/F Spare 1
I/F Spare 2	I/F Spare 3

Pulse Settings

	High 50ms
	High 100ms
	Low 50ms
	Low 100ms
1	4
2	8

Inhibits

Bill 1	Bill 5
Bill 2	Bill 6
Bill 3	Bill 7
Bill 4	Bill 8

Options

High Speed	cctalk plain
Start Disabled	cctalk 8 bit chk
Low Power	Binary
option spare 2	option spare 3

Pulses Per Dollar

Pulse – Pulse width 50/50 mS
1 Pulse per Dollar

Pulse – Pulse width 50/100 mS
4 Pulses per Dollar

MDB

Insert this end first

v 1.1*

SIO 300-Baud

Insert this end first

v 1.1*

SIO 300-Baud Starts Disabled

Insert this end first

v 1.1*

SIO 9600-Baud

Insert this end first

v 1.1*

SIO 9600-Baud Starts Disabled

Interface	Pulse Settings	Inhibits	Options
SSP	High 50ms	BIII 1	High Speed
PULSE	High 100ms	BIII 2	cctalk plain
MDB	Low 50ms	BIII 3	Start Disabled
IF 30	Low 100ms	BIII 4	Low Power
IF 31	1	BIII 5	option spare 2
CCTALK	2	BIII 6	option spare 3
PARALLEL	4	BIII 7	
IF Spare 4	8	BIII 8	
NIS	Pulses Per Dollar		
IF 32	Speed		
IF Spare 1			
IF Spare 2			
IF Spare 3			

Interface	Pulse Settings	Inhibits	Options
SSP	High 50ms	BIII 1	High Speed
PULSE	High 100ms	BIII 2	cctalk plain
MDB	Low 50ms	BIII 3	Start Disabled
IF 30	Low 100ms	BIII 4	Low Power
IF 31	1	BIII 5	option spare 2
CCTALK	2	BIII 6	option spare 3
PARALLEL	4	BIII 7	
IF Spare 4	8	BIII 8	
NIS	Pulses Per Dollar		
IF 32	Speed		
IF Spare 1			
IF Spare 2			
IF Spare 3			

Interface	Pulse Settings	Inhibits	Options
SSP	High 50ms	BIII 1	High Speed
PULSE	High 100ms	BIII 2	cctalk plain
MDB	Low 50ms	BIII 3	Start Disabled
IF 30	Low 100ms	BIII 4	Low Power
IF 31	1	BIII 5	option spare 2
CCTALK	2	BIII 6	option spare 3
PARALLEL	4	BIII 7	
IF Spare 4	8	BIII 8	
NIS	Pulses Per Dollar		
IF 32	Speed		
IF Spare 1			
IF Spare 2			
IF Spare 3			

Interface	Pulse Settings	Inhibits	Options
SSP	High 50ms	BIII 1	High Speed
PULSE	High 100ms	BIII 2	cctalk plain
MDB	Low 50ms	BIII 3	Start Disabled
IF 30	Low 100ms	BIII 4	Low Power
IF 31	1	BIII 5	option spare 2
CCTALK	2	BIII 6	option spare 3
PARALLEL	4	BIII 7	
IF Spare 4	8	BIII 8	
NIS	Pulses Per Dollar		
IF 32	Speed		
IF Spare 1			
IF Spare 2			
IF Spare 3			

Appendix E – PC System Specification

The ITL Validator Software has been tested and verified using Windows 2000/XP/Vista™ on a Pentium™ based PC System (© Microsoft and Intel). Full functionality cannot be guaranteed on lower specification systems.

Appendix F – Low Power Mode

Notes:

- Low Power Mode can only be used with Parallel, Pulse and Binary configurations.
- Low power mode can only be enabled by correctly completing the configuration cards or via the ITL BNV Currency manager program.
- In Low Power Mode the front sensor is checked every 1 second which can lead to a delay in accepting the note when it is presented.
- Configuration button functions are only available during power up before the BV20 goes into Low Power mode

Low power Mode can be used with all none serial communication protocols to reduce the power consumption of the BV20 when idle. When the BV20 is in this state the current consumption is reduced to approximately 1mA. The BV20 goes into low power mode approximately 4 seconds after the validator is powered up and remains in this state until a note is entered (Time A). Following a note insertion the BV20 returns to Low Power mode approximately 1 second after the Busy line goes High (After credit is given or note is rejected). (Time B)

Low Power mode uses 3 control lines: Vend – Pin 1, Inhibit – Pin 5 and Busy – Pin 9

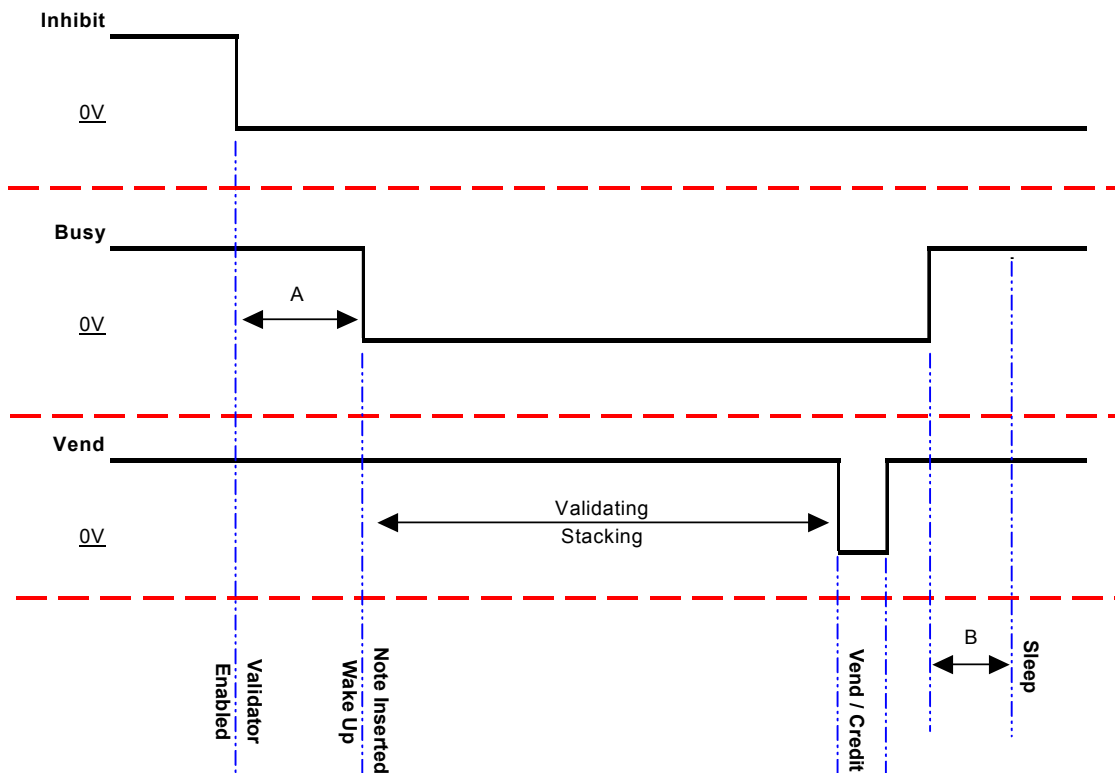

Figure 11 - Low Power Mode Timing Diagram

TIMING DIAGRAM

When the Validator is enabled the Inhibit line is Low and the Busy line is High. This remains the same until a note is inserted (Time A)

When a note is inserted under the front sensor the BV20 wakes up and the busy line goes low to indicate that the validator is in use. The busy line remains low during the validating and stacking process and once the note has been successfully validated and stacked the vend line goes low to issue the credit.

After the credit is issued the busy line goes high and approximately 1 second after the busy line goes high (Time B) the BV20 goes back into low power mode.