



Your Automation Site !



LBGSMMODEM31

GSM GPRS MODEM SERIES

User's Manual

1 of 27



PLCs



Acquisition



Instruments



Data logger



Power



HMIs



Switches



Motion



Sensors



Converters



Keyboards

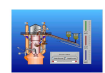

SCADA



Telemetry

List of abbreviations

ACM	Accumulated Call Meter	MO	Mobile Originated
AT	ATtention (prefix for modem commands)	MS	Mobile Station
CS	Coding Scheme	MT	Mobile Terminated
CTS	Clear To Send	NC	Not Connected
DC	Direct Current	PCL	Power Control Level
DCD	Data Carrier Detect	PDP	Packet Data Protocol
DCE	Data Communication Equipment	PDU	Protocol Data Unit
DCS	Digital Cellular System	PIN	Personal Identification Number
DSR	Data Set Ready	PLMN	Public Land Mobile Network
DTE	Data Terminal Equipment	PSTN	Public Switched Telephone Network
DTR	Data Terminal Ready	PUK	Personal Unblocking Key
EMI	Electro Magnetic Interference	RF	Radio Frequency
ESD	Electro Static Discharges	RFI	Radio Frequency Interference
FAQ	Frequently Asked Question	RI	Ring Indicator
GND	GrouND	RTS	Request To Send
GPRS	General Packet Radio Service	RX	Receive
GSM	Global System for Mobile communications	SIM	Subscriber Identification Module
I/O	Input / Output	SMS	Short Message Service
ISDN	Integrated Service Digital Network	TX	Transmit
LED	Light Emitting Diode	VRMS	Volt Root Mean Square
ME	Mobile Equipment	VSWR	Voltage Standing Wave Ratio

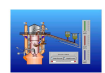
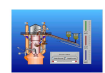

Table of Contents

1	General description	5
1.1	Introduce	5
1.2	Features	5
1.3	External connections	6
1.4	Package content	7
2	Functional description	8
2.1	Architecture	8
2.2	RS232 serial link	8
3	Characteristics	10
3.1	Basic services	10
3.2	Physical characteristics	11
3.3	Electrical characteristics	11
3.4	Environmental characteristics	12
4	Using the modem	13
4.1	Getting started with the modem	13
4.2	Operational status of the modem	14
4.3	Verifying the received signal strength	14
4.4	Verifying the network registration of the modem	14
5	AT commands for the modem	15
6	Troubleshooting	16
6.1	No connection with the modem through the serial link	16
6.2	Receiving “ERROR” message	17
6.3	Receiving “No carrier” message	19
7	Safety recommendations	21
7.1	General Safety	21
7.2	Vehicle Safety	22
7.3	Care And Maintenance	22
7.4	Your Responsibility	23
8	Proper Usage	24
8.1	Use accessories in the original packaging	24



8.2 Prevent embezzlement.....24

8.3 Proper usage.....24

9 Quality guarantee24

10 GPRS Modem Internet Access setup guide25



PLCs



Acquisition



Instruments



Data logger



Power



HMIs



Switches



Motion



Sensors



Converters



Keyboards

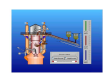

SCADA



Telemetry

1 General description

1.1 Introduce

The modem is a self-contained E-GSM/GSM-GPRS 900/1800 dual-band modem and is GPRS class 10 capable.

This modem supports the following transmissions:

- Data,
- Fax,
- Short Messages (Point to point and Cell Broadcast),
- Voice calls.

The modem comprises several interfaces:

- LED function indicating the operating status,
- External antenna (via SMA connector),
- RS232 Serial (via 9-pin SUB HD connector),
- Power supply (via 2.5mm DC power jack),
- SIM card holder.

1.2 Features

The main features of the modem are the following:

- 2 Watts E-GSM 900 radio section.
- 1 Watt GSM1800 radio section.
- Echo Cancellation + noise reduction.
- Full GSM or GSM / GPRS software stack.
- Hardware GPRS class 10 capable.
- Complete shielding.
- A DC Power supply.
- A RS232 serial link.
- A 1.8V / 3.3V SIM interface.



1.3 External connections

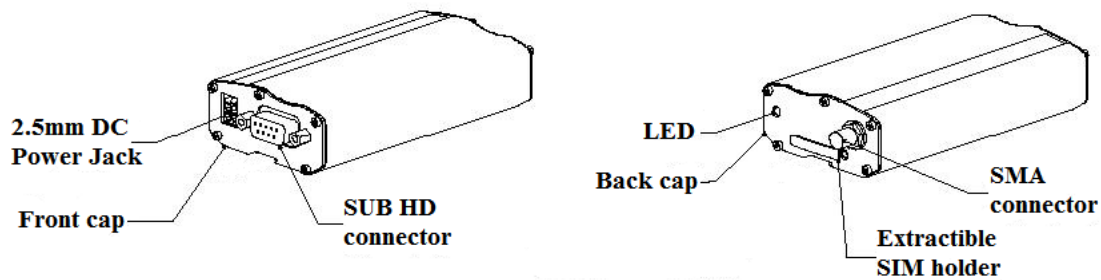

fig. 1 Modem Presentation

The modem has three external connections:

- Antenna connector: SMA connector for RF connection to the antenna,
- Sub D high density 9-pin connector for RS232 serial link connection,
- Power supply connector: 2.5mm power jack for DC Power Supply.

1.3.1 Power supply connector

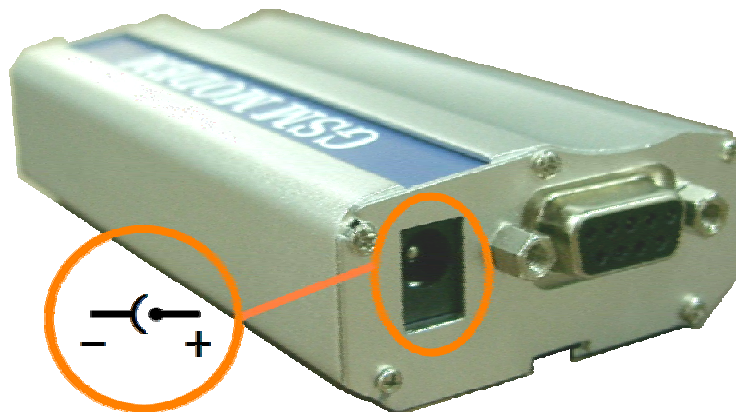

fig. 2 Power supply connector

1.3.2 Antenna connector



fig. 3 Antenna connector

1.3.3 Sub HD 9-pin connector

6 of 27



fig. 4 Sub HD 9-pin connector

Pin #	Signal (EIA / CCITT)	I/O	I/O type	Description	Comment
1	DCD / CT109	O	RS232 STANDARD	RS232 Data Carrier Detect	
2	TX / CT103	O	RS232 STANDARD	RS232 Transmit serial data	
3	RX / CT104	I	RS232 STANDARD	RS232 Receive serial data	
4	DTR / CT108-2	I	RS232 STANDARD	RS232 Data Terminal Ready	
5	GND	-	GND	Ground	
6	DSR / CT107	O	RS232 STANDARD	RS232 Data Set Ready	
7	CTS / CT106	O	RS232 STANDARD	RS232 Clear To Send	
8	RTS / CT105	I	RS232 STANDARD	RS232 Request To Send	
9	RI / CT125	O	RS232 STANDARD	RS232 Ring Indicator	

1.4 Package content

The modem package includes:

- modem x 1
- External AC adapter x 1
- RS-232 connecting cable x 1
- 0dBi Antenna x 1
- User's manual x 1
- Warranty Card x 1

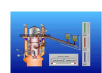

2 Functional description

2.1 Architecture

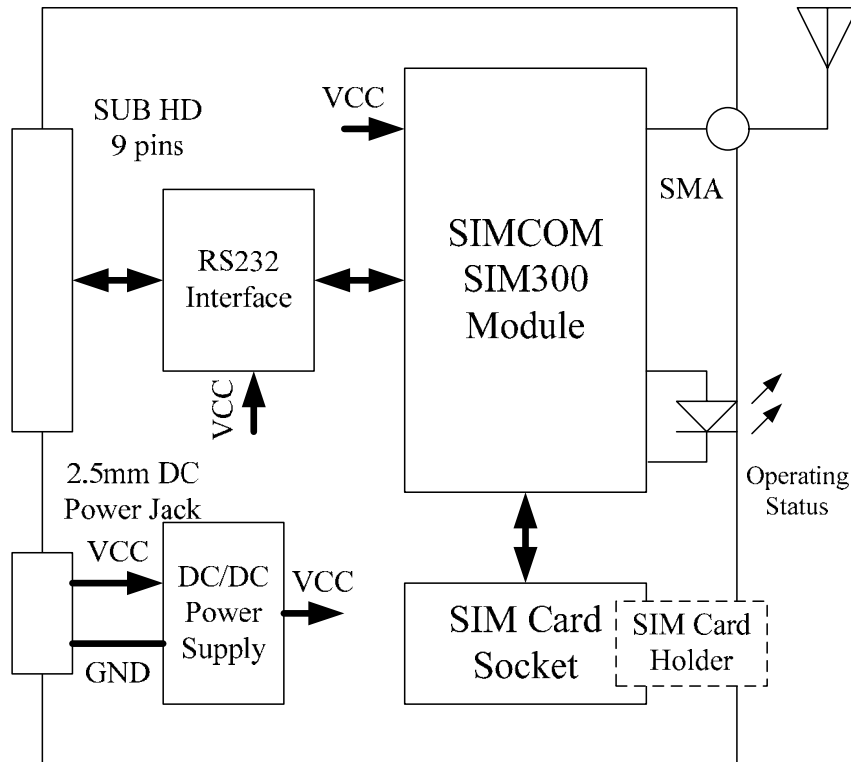

fig. 5 Modem Functional architecture

2.2 RS232 serial link

2.2.1 General presentation

The RS232 interface performs the voltage level adaptation (V24/CMOS V24/V28) between the internal SIMCOM module (DCE) and the external world (DTE).

The RS232 interface is protected (by ESD protection) against electrostatic surges on the RS232 lines.

Filtering guarantees:

- EMI/RFI protection in input and output,
- Signal smoothing.

A flexible 6-wire serial interface is available complying with RS232 protocol signaling.

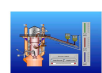

The signals available are:

- TX data (TX / CT103),
- RX data (RX / CT104),
- Request To Send (RTS / CT105),
- Clear To Send (CTS / CT106),
- Data Terminal Ready (DTR / CT108-2),
- Data Set Ready (DSR / CT107).

The 2 additional signals are Data Carrier Detect (DCD / CT109) and Ring Indicator (RI / CT125).

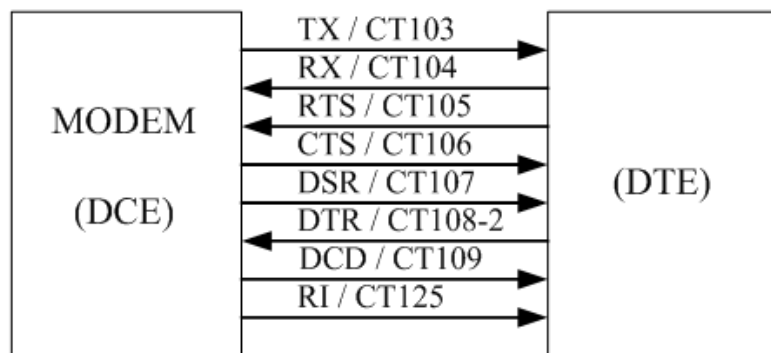

fig. 6 RS232 Serial Link signals

RS232 interface has been designed to allow a certain flexibility in the use of the serial interface signals. However, the use of TX, RX, CTS and RTS signals is mandatory which is not the case for DTR, DSR, DCD and RI signals which can be not used.

2.2.2 Pin out description

Signal	Pin #	I/O	I/O type RS232 STANDARD	Description
TX / CT103	2	O	TX	Transmit serial data
RX / CT104	3	I	RX	Receive serial data
RTS / CT105	8	I	RTS	Request To Send
CTS / CT106	7	O	CTS	Clear To Send
DSR / CT107	6	O	DSR	Data Set Ready
DTR / CT108-2	4	I	DTR	Data Terminal Ready
DCD / CT109	1	O	DCD	Data Carrier Detect
RI / CT125	9	O	RI	Ring Indicator
GND / CT102	5	-	GND	Ground

3 Characteristics

3.1 Basic services

The basic services of the modem are given in the table below.

	GSM	DCS
Standard	900 MHz E-GSM compliant Class 4 (2W). GSM phase 2.	1800 MHz E-GSM compliant Class 1 (1W) GSM phase 2.
Interface	Serial interface RS232 V.24/V.28 AT command set based on V.25ter and GSM 07.05 & 07.07. Auto-bauding function between 2400 bits/s and 19200 bits/s No auto-framing available	Serial interface RS232 V.24/V.28 AT command set based on V.25ter and GSM 07.05 & 07.07. Auto-bauding function between 2400 bits/s and 19200 bits/s No auto-framing available
SMS	Mobile Originated (MO) and Mobile Terminated (MT). Mode Text & PDU point to point. Cell broadcast.	Mobile Originated (MO) and Mobile Terminated (MT). Mode Text & PDU point to point. Cell broadcast.
Data	In accordance with GSM 07.05 Asynchronous 2400, 4800, 9600 and 14400 bits/s. Transparent and Non-Transparent mode In Non Transparent Mode: 300, 1200, 1200/75 bauds. Mode 3.1 kHz (PSTN) and V110 (ISDN)	In accordance with GSM 07.05 Asynchronous 2400, 4800, 9600 and 14400 bits/s. Transparent and Non-Transparent mode In Non Transparent Mode: 300, 1200, 1200/75 bauds. Mode 3.1 kHz (PSTN) and V110 (ISDN)
Fax	2400/4800/7200/9600 bits/s, GSM teleservice 62 in Transparent Mode. Class 1 & Class 2. Group 3 compatible.	2400/4800/7200/9600 bits/s, GSM teleservice 62 in Transparent Mode. Class 1 & Class 2. Group 3 compatible.
GPRS	Class 10. Coding schemes: CS1 to CS4 Compliant with SMG31bis	Class 10. Coding schemes: CS1 to CS4 Compliant with SMG31bis

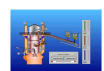

3.2 Physical characteristics

Dimensions	98mm×54mm×25mm (without connectors)
Overall Dimension	110mm×54mm×25mm
Weight	< 130g
Volume	132.3 cm ³
Housing	Aluminum profiled

3.3 Electrical characteristics

3.3.1 Power supply

Table 1: Electrical characteristics

Operating Voltage ranges	5 V to 32 V DC (GSM or DCS).
	5.5 V to 32 V DC (GPRS Class 10).
Maximum current	480 mA Average at 5.5V.
	1.7 A Peak at 5V.

Note: the modem is permanently powered once the power supply is connected. The following table describes the consequences of over voltage and under voltage with the GSM/GPRS Modem.

Table 2: Effects of power supply defect

If the voltage:	Then:
falls below 5V	The GSM communication is not guaranteed.
falls below 5.5V	The GPRS Class 10 is not guaranteed.
Voltage over 32V (Transient peaks)	The modem guarantees its own protection.
Voltage over 32V (continuous overvoltage)	Protection of the modem by the fuse (the supply voltage is disconnected).

The following table provides information on power consumption of the Fastrack modem, assuming an operating temperature of +25 °C and using a 3 V SIM card.

3.3.2 RF characteristics

3.3.2.1 Frequency ranges

Table 4: Frequency ranges

Characteristic	E-GSM 900	DCS 1800
Frequency TX	880 to 915 MHz	1710 to 1785 MHz
Frequency RX	925 to 960 MHz	1805 to 1880 MHz

3.3.2.2 RF performances

RF performances are compliant with the ETSI recommendation GSM 05.05.



The RF performances for receiver and transmitter are given in the table below.

Table 5: Receiver and transmitter RF performances

Receiver	
E-GSM900 Reference Sensitivity	-104 dBm Static & TUHigh
DCS1800 Reference Sensitivity	-102 dBm Static & TUHigh
Selectivity @ 200 kHz	> +9 dBc
Selectivity @ 400 kHz	> +41 dBc
Linear dynamic range	63 dB
Co-channel rejection	>= 9 dBc
Transmitter	
Maximum output power (E-GSM 900) at ambient temperature	33 dBm +/- 2 dB
Maximum output power (DCS1800) at ambient temperature	30 dBm +/- 2 dB
Minimum output power (E-GSM 900) at ambient temperature	5 dBm +/- 5 dB
Minimum output power (DCS1800) at ambient temperature	0 dBm +/- 5 dB

3.3.2.3 External antenna

The external antenna is connected to the modem via the SMA connector. The external antenna must fulfill the characteristics listed in the table below.

Table 6: External antenna characteristics

Antenna frequency range	Dual-band GSM 900/DCS 1800 MHz
Impedance	50 Ohms
Gain (antenna + cable)	0 dBi
VSWR (antenna + cable)	-10 dB

Note: refer to chapter 8 for recommended antenna.

3.3.3 SIM card

Table 7: SIM card characteristics

SIM card	1.8V or 3.3V
----------	--------------

3.4 Environmental characteristics

To ensure the proper operation of the Modem, the operating environment must be within a specific temperature as described in the table below.

Table 9: Ranges of temperature

Operating temperature range	-20 °C to +55 °C
Storage temperature range	-25 °C to +70°C

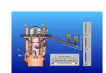

4 Using the modem

4.1 Getting started with the modem

4.1.1 Setting up the modem

To set up the modem, do the following:

- 1 Press SIM card holder ejector (yellow button) with a sharp object (the tip of a pen for example).
- 2 Insert the SIM card in the holder.
- 3 Verify the SIM card fits in the holder properly.
- 4 Connect the antenna to the SMA connector.
- 5 Connect both sides of the serial cable (9-pin Sub HD connector on the modem side).
- 6 Connect the power supply cable to the power supply source.
Note: for automotive application, it is recommended to connect the V+ line of the modem directly to the positive terminal of the battery.
- 7 Plug the power supply cable into the modem and switch on the external power supply.
- 8 Now the modem is ready to work. Refer to chapter 5 for some AT commands to configure the modem.

4.1.2 Checking the communication with the modem

Connect the RS232 link between the DTE (port COM) and the modem (DCE). Configure the RS232 port of the DTE as follows:

- Bits per second: 115.200 kbps,
- Data bits: 8,
- Parity: None,
- Stop bits: 1,
- Flow control: Hardware Flow control.

Using a communication software such as HyperTerminal program, enter the **AT** command. The response of the modem must be OK displayed in the HyperTerminal window.

If the communication cannot be established with the modem, do the following:

- Check the RS232 connection between the DTE and the modem (DCE),
- Check the configuration of the port COM used on the DTE.

Example of AT commands which can be used after getting started the modem:

- AT+CGMI: modem answer is "WAVECOM MODEM" when serial link is OK.
- AT+CPIN=<Pin Code>: to enter a PIN code (if activated).
- AT+CSQ: to verify the received signal strength.
- AT+CREG?: to verify the registration of the modem on the network.
- ATD<phone number>;: to initiate a call.
- ATH: to hang up (end of call).

For further information about these AT commands and their associated parameters, refer to document [1].

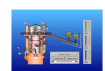

4.2 Operational status of the modem

The operational status of the modem is given by the LED light located on the front panel of the modem. The table below gives the meaning of the various statuses available.

Table 10: Operational status of the modem

LED Status	LED light activity	Modem status
ON	LED ON permanent	Modem is switched on Not registered on the network
	LED Flashing slowly	Idle mode Connected to the network
	LED Flashing rapidly	Transmission mode
OFF	LED OFF	Modem is switched off

4.3 Verifying the received signal strength

The modem establishes a call only if the received signal is sufficiently strong. To verify the received signal strength, do the following:

Using a communication software such as HyperTerminal program, enter the AT command AT+CSQ. Value appears for the received signal strength.

Verify the result with the values given in the table below.

Table 11: Values of received signal strength

Value of received signal strength (AT+CSQ response)	Interpretation of the received signal strength
0 - 10	Insufficient(*)
11 - 31	Sufficient(*)
Greater than 99	Insufficient(*)

(*) Based on general observations.

4.4 Verifying the network registration of the modem

1. Make sure a valid SIM card has been previously inserted in the SIM card holder of the modem.
2. Using a communication software such as HyperTerminal program, enter the following AT command: AT+CREG?. Value appears as a response.
3. Verify the result with the values given in the table below.

Table 12: Values of network registration

Value(*)	Network registration
0,1	Yes
0,5	Yes (registered roaming)

(*) refer to AT commands documentation [1] for further information about the other returned values and their meaning.

If the modem is not registered, perform the following procedure:

- Check the connection between the modem and the antenna.
- Verify the signal strength to determine the strength of the received signal (refer to

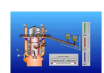

paragraph 4.3).

5 AT commands for the modem

The table below reminds the main AT commands required for getting started the modem. For other AT commands available or further information about the AT commands, refer to document [1].

Description	AT commands	Modem's response	Comment
Enter PIN Code	AT+CPIN=1234	OK	PIN Code accepted.
		+CME ERROR: 16	Incorrect PIN Code (with +CMEE = 1 mode).
		+CME ERROR: 3	PIN already entered (with +CMEE = 1 mode).
Modem synchronization checking	AT+CREG?	CREG=<mode>, 1	Modem synchronised on the network.
		CREG=<mode>, 2	Synchronization lost, resynchronization attempt.
		CREG=<mode>, 0	Modem not synchronized on the network, no synchronization attempt.
Receiving an incoming call	ATA	OK	Answer the call.
Initiate a call (Don't forget the ";" at the end for « voice » call)	ATD<phone number>;	OK	Communication established.
		CME ERROR: 11	PIN code not entered (with +CMEE = 1 mode).
		CME ERROR: 3	AOC credit exceeded or a communication is already established.
Communication loss		NO CARRIER	
Hang up	ATH	OK	
Store the parameters in EEPROM	AT&W	OK	The configuration settings are stored in EEPROM.

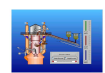

6 Troubleshooting

This section of the document describes possible problems encountered when using the modem and their solutions.

6.1 No connection with the modem through the serial link

If the modem does not answer through the serial link, refer to the table below for possible causes and solutions.

Table 13: Solutions for no connection with modem through serial link

If the modem returns...	Then ask	Action
Nothing	Is the modem powered correctly?	Provide a power supply in the range of 5 V (5.5V for GPRS Class 10) to 32 V.
	Does the serial cable follow correctly pin assignment shown in paragraph 1.2.1.3.	Connect the cable by following pin assignment given in paragraph 1.2.1.3.
	Is the communication program properly configured?	Ensure the setting of the communication program is fit to setting of modem. Modem factory setting is: Data bits = 8 Parity = none Stop bits = 1 Baud = 115.200 kbps. Flow control = Hardware
	Is there another program interfering with the communication program (i.e. Conflict on communication port access)	Close the application (e.g. mouse or printer driver).

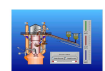

6.2 Receiving “ERROR” message

If the modem returns a message of ERROR upon an attempted transmission of data, or voice signals, then refer to the table below for possible causes and solutions.

Table 14: Solutions for “ERROR” message

If the modem returns...	Then ask	Action
ERROR	Is the modem registered on the network? Refer to paragraph 4.4 to network?	verify that the modem is registered on the network.
	Is the modem receiving an incoming call or is it already in communication?	End any incoming by using ATH command.
	Is the selected bearer type supported by the called party? Is the selected bearer type supported by the network?	Enter AT+CMEE to view the extended error code. Note: Refer to Table 15. Ensure that the selected bearer type is supported by the called party. Ensure that the semicolon (;) is entered immediately after the phone number in the AT command. e.g. ATD#####;
	Is the received signal strong enough?	Refer to paragraph 4.3 to verify the strength of the received signal.
	Is the antenna properly connected?	Refer to paragraph 3.3.2.3 for antenna requirements

If the modem returns a message of ERROR, you can have the extended error code by using AT command AT+CMEE=1. Refer to the table below for interpretation of extended error code.

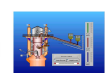
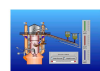

Table 15: Interpretation of extended error code

Error Code	Diagnostic	Hint
0	Phone failure	Call your technical support.
3	Operation not allowed	No action.
4	Operation not supported	
10	SIM not inserted	If SIM card is inserted, check the SIM card if it is clean and properly inserted.
11	SIM PIN required	Enter PIN code.
12	SIM PUK required	Enter PUK code. Note: Call your network provider if you don't know this code.
13	SIM Failure	Check validity of your SIM card. If SIM card damaged, call your network provider.
16	Incorrect password	Check the code you entered.
17	SIM PIN2 required	Enter PIN2 code.
18	SIM PUK2 required	Enter PUK2 code (call your network provider if you don't know this code).
26	Dial string too long	Check your phone number (max 20 digits).
30	No network service	No action.
32	Network not allowed Emergency calls only	No action.
40	Network personalization PIN required (Network lock)	Enter Network lock code (call your network provider if you don't know this code).
103	Illegal MS (#3)	No action.
106	Illegal ME (#6)	No action.
107	GPRS services not allowed (#7)	Contact your network provider to subscribe to the GPRS services.
111	PLMN area not allowed (#11)	No action.
112	Location area not allowed (#12)	No action.
113	Roaming not allowed in this location area (#13)	No action.
132	Service option not supported (#32)	Check the service option.
133	Requested service option not subscribed (#33)	Call your network provider to subscribe to the requested service option.
134	Service option temporarily out of order (#34)	No action.
148	Unspecified GPRS error	No action.
149	PDP authentication failure	Call your network provider to know the right authentication parameters.
150	Invalid mobile class	Change the class of the mobile to a valid one.

Note: For all other codes, and/or details, refer to AT commands documentation.



6.3 Receiving “No carrier” message

If the modem returns a message of No carrier upon an attempted transmission of data, or voice signals, then refer to the table below for possible causes and solutions.

Table 16: Solutions for “No carrier” message

If the modem returns...	Then ask...	Action...
No carrier	Is the received signal strong enough?	Refer to paragraph 4.3 to verify the strength of the received signal.
	Is the antenna properly connected?	Refer to paragraph 3.3.2.3 for antenna requirements.
No carrier (when trying to issue a voice communication)	Is the semicolon (;) entered immediately after the phone number in the AT command?	Ensure that the semicolon (;) is entered immediately after the phone number in the AT command. e.g. ATD#####;
No carrier (when trying to issue a data communication)	Is SIM card configured for data / fax calls?	Configure the SIM card for data / fax calls (Ask your network provider if necessary).
	Is the selected bearer type supported by the called party?	Ensure that the selected bearer type is supported by the called party.
	Is the selected bearer type supported by the network?	Ensure that the selected bearer type is supported by the network. If no success, try bearer selection type by AT command: AT+CBST=0,0,3

If the modem returns a message of No carrier, you can get the extended error code by using AT command AT+CEER. Refer to the table below for interpretation of extended error code.

Table 17: Interpretation of extended error code

Error Code	Diagnostic	Hint
1	Unallocated phone number	Not applicable.

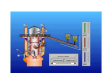

16	Normal call clearing	
17	User busy	
18	No user responding	
19	User alerting, no answer	
21	Call rejected	
22	Number changed	
31	Normal, unspecified	
50	Requested facility not subscribed	Check your subscription (data subscription available?).
68	ACM equal or greater than ACM max	Credit of your pre-paid SIM card expired.
252	Call barring on outgoing calls	Not applicable.
253	Call barring on incoming calls	
3, 6, 8, 29, 34, 38, 41,42, 43, 44, 47, 49, 57, 58, 63, 65, 69, 70, 79, 254	Network causes	See AT commands manual for further details or call network provider.

Note: For all other codes, and/or details, see AT commands documentation.

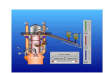

7 Safety recommendations Safety recommendations

7.1 General Safety

Please read these simple guidelines carefully. It is important to follow any special regulations regarding the use of radio equipment due in particular to the possibility of Radio Frequency (RF) interference. Please follow the safety advice given below carefully.



Switch on Safety

Respect restrictions on the use of radio equipment in fuel depots, chemical plants or where blasting operations are in progress. Do not switch the modem on when wireless device use is prohibited or when it may cause interference or danger.

Switch OFF your GSM Modem when in an aircraft. The use of cellular telephones in an aircraft may endanger the operation of the aircraft, disrupt the cellular network and is illegal. Failure to observe this instruction may lead to suspension or denial of cellular telephone services to the offender, or legal action or both.

Switch OFF your GSM Modem when at a refueling point.

Switch OFF your GSM Modem in hospitals and any other place where medical equipment may be in use. There may be a hazard associated with the operation of your GSM Modem close to in adequately protected personal medical devices such as hearing aids and pacemakers. Consult the manufactures of the medical device to determine if it is adequately protected.

Interference

All modem may be susceptible to interference, which could affect performance. Operation of your GSM Modem close to other electronic equipment may also cause interference if the equipment is inadequately protected. Observe any warning signs and manufacturers recommendations.



Switch off when refueling

Do not use the modem at a refueling point. Do not use near fuel or chemicals.



Switch off near blasting

Follow any restrictions. Do not use the the GSM/GPRS/CDMA modem where blasting is in progress.



Use sensibly

Use only in the normal position as explained in the product documentation. Do not touch the antenna unnecessarily.

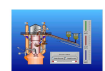



Qualified service

Only qualified personnel may install or repair this product.



Water-resistance

Your product is not water-resistant. Keep it dry.

The modem is designed for and intended to be used in fixed and mobile applications:

“Fixed” means that the device is physically secured at one location and is not able to be easily moved to another location.

“Mobile” means that the device is designed to be used in other than fixed locations and generally in such a way that a separation distance of at least 20 cm (8 inches) is normally maintained between the transmitter’s antenna and the body of the user or nearby persons.

The Modem is not designed for and intended to be used in portable applications (within 20 cm of the body of the user) and such uses are strictly prohibited.

7.2 Vehicle Safety

Do not use your GSM Modem while driving, unless equipped with a correctly installed vehicle kit allowing 'Hands-Free' Operation.

Respect national regulations on the use of cellular telephones in vehicles. Road safety always comes first.

If incorrectly installed in a vehicle, the operation of GSM Modem telephone could interfere with the correct functioning of vehicle electronics. To avoid such problems, ensure that the installation has been performed by a qualified personnel. Verification of the protection of vehicle electronics should form part of the installation.

The use of an alert device to operate vehicle’s lights or horn on public roads is not permitted.

7.3 Care And Maintenance

Your GSM Modem is the product of advanced engineering, design and craftsmanship and should be treated with care. The suggestion below will help you to enjoy this product for many years.

Do not expose the GSM Modem to any extreme environment where the temperature or humidity is high.

Do not attempt to disassemble the GSM Modem. There are no user serviceable parts inside.

Do not expose the GSM Modem to water, rain or spilt beverages, It is not waterproof.

Do not abuse your GSM Modem by dropping, knocking, or violent shaking. Rough handling can damage it.

Do not place the GSM Modem alongside computer discs, credit or travel cards or other magnetic media. The information contained on discs or cards may be affected by the

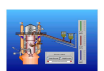

phone.

The use of third party equipment or accessories, not made or authorized by SIMCOM may invalidate the warranty of GSM Modem.

Do contact an authorized Service Center in the unlikely event of a fault.

7.4 Your Responsibility

This GSM Modem is under your responsibility. Please treat it with care respecting all local regulations. It is not a toy therefore keep it in a safe place at all times and out of the reach of children.

Try to remember your Unlock and PIN codes. Become familiar with and use the security features to block unauthorized use and theft.



PLCs



Acquisition



Instruments



Data logger



Power



HMIs



Switches



Motion



Sensors



Converters



Keyboards

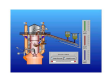

SCADA



Telemetry

8 Proper Usage

8.1 Use accessories in the original packaging

Please only use accessories in the original packing or those approved by supplier. It may cause malfunctions and shorten life-span of the product if using unapproved accessories.

8.2 Prevent embezzlement

If you lost modem with SIM card, contact your GSM/GPRS/CDMA service provider immediately to prevent embezzlement.

8.3 Proper usage

Turn off the power before you insert or remove the SIM card

9 Quality guarantee

- We provide one-year quality guarantee. We will repair the modem free of charge if quality problems arise from normal using and under normal operation conditions. We are not responsible for any related costs or damages caused directly or indirectly by malfunction.
- It will be charged for maintenance after the guarantee period.
- Shipping charge will be shared half/half during the guarantee period, and will be afforded by buyer after guarantee period.
- We will return the product in 15 days (shipping date excluded), depends on how it damaged.
- You should return the full package when sending back for repairing. Insulation method and ant-extrusion method should be taken.

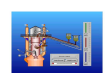

10 GPRS Modem Internet Access setup guide

Step 1: Install modem

1. Connect modem with PC, then power up modem
2. Double click **Phone and Modems Options** in **Control Panel**
3. Select **Modems** in **Phone and Modems Options** and click **Add** button



4. Select '**Don't detect my modem; I will select if from a list.**' → Select **Standard Modems Types** → Select **Standard 33600 bps Modem** → Select relevant port of modem plugged in → Complete modem installation.

Step 2: Setup modem

1. Click **Properties** and select **Advanced** option.

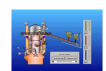

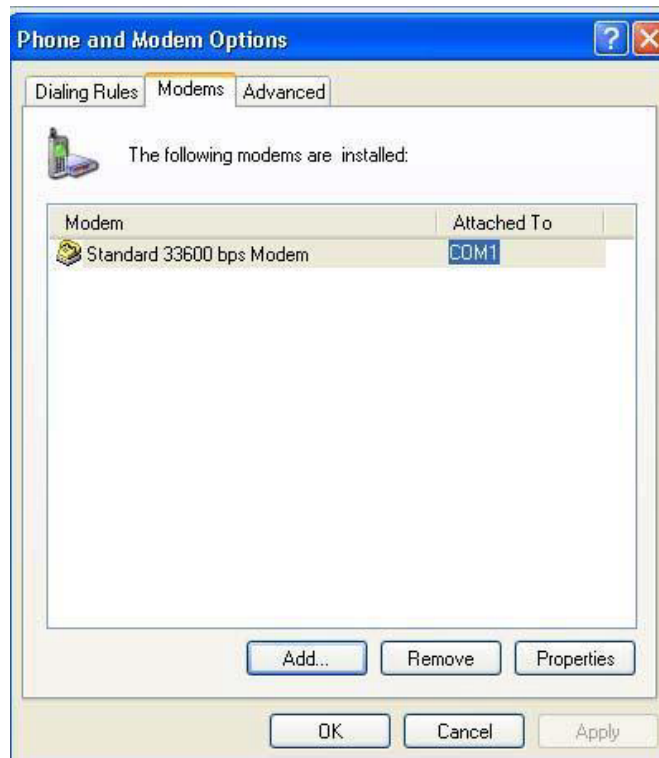

2. Enter AT command **AT+CGDCONT=1,"IP","CMNET"** into textbox.

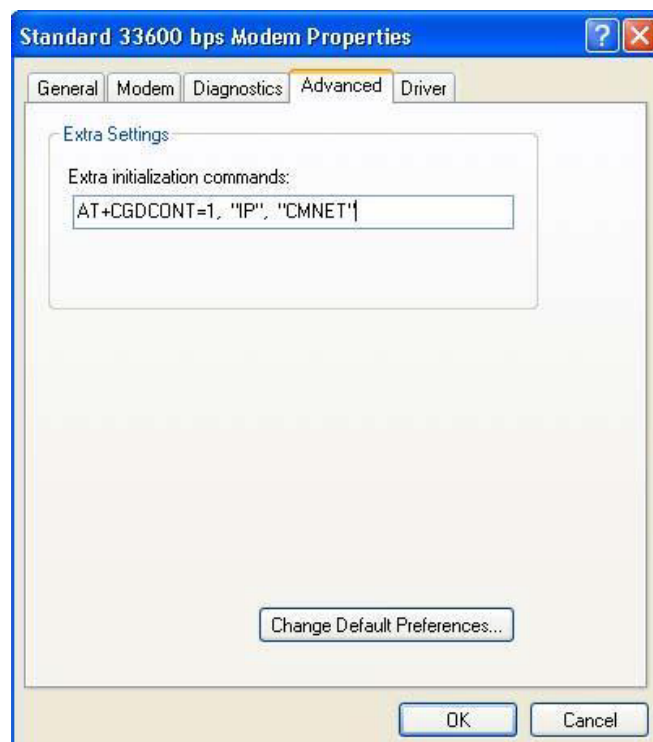

Step 3: Establish dial connection

1. Establish **Dial Connection**. Dial number is ***99***1#** or ***99#**, User name and Password leave empty.





2. Click the icon from **Network Connection** to initial connection.



3. After initial period, the connection is on.



Note: Turn off the power before you insert or remove the SIM card.

