

GOLDAIR

Operating Instructions

Metro 4 Burner BBQ With Side Burner



Model: GBQMT1

BBQ

Please read these instructions & user manual carefully.

- Take extra care when unpacking and assembling your Goldair BBQ. Some edges may be sharp from the manufacturing process and may result in cuts if not handled with care.
- Before attempting to assemble your Goldair BBQ, ensure all parts are correct and contained within the box as per the components list.
- Goldair suggests laying out all components on a large flat surface and removing any plastic or protective material before assembling your BBQ.
- If your BBQ has lockable castors ensure these are locked before attempting to assemble otherwise the BBQ may move during assembling resulting in injury.
- Do not dispose of packaging until completely satisfied with assembly of your BBQ

Please refer to your user manual for operating instructions, further information or trouble shooting before you call the Customer Service number listed within the user manual.

If your BBQ has any Stainless Steel please note the following:

Note: Stainless Steel will rust.

Failure to store with a BBQ cover, and to clean & maintain your BBQ regularly will result in Stainless Steel 'tea staining' & rusting. Consequently it will not be covered by the warranty.

Goldair recommends the use of stainless steel protectors & cleaners to also prolong the life of your BBQ.

Please refer to your user manual.

GAS LEAK TESTING

It is important that you leak test the BBQ before first use and every time the gas cylinder is refilled and reconnected to the BBQ.

To complete a Leak Test:

- Make sure all the control knobs are OFF.
- In a small container, mix up a solution of water and detergent/soap. Mix the solution well (about the same concentration as washing up water).
- Turn the cylinder ON by rotating the knob to the open position.
- Using a brush or spray bottle apply the soap solution to the gas line and each join in the gas line including:
 - The gas connection at the inlet of the BBQ
 - The gas hose
 - The gas connection at the gas cylinder
- If bubbles appear, there is a gas leak.
- If the leak is at the connection, re-tighten and re-seal.
- If the leak is anywhere else or you cannot resolve the leak by tightening the connection **DO NOT PROCEED**.
- Replace gas hose and regulator.
- Replacement hose and regulators can be purchased from your local BBQ retail specialist

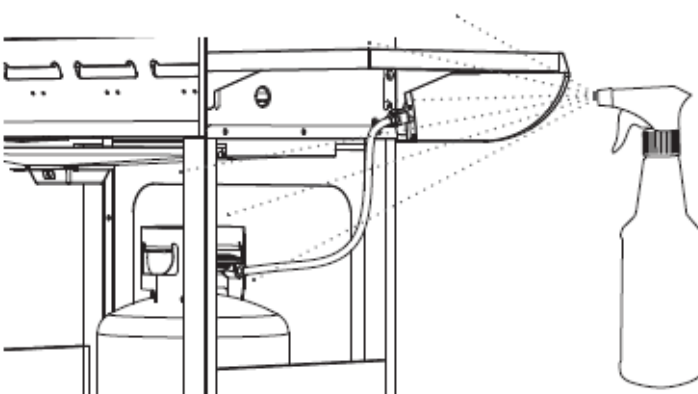

- **Do not operate this BBQ before reading the instruction booklet**
- **Do not place articles on or against this BBQ**
- **Do not use or store flammable or combustible materials, chemicals or spray aerosols near your BBQ**
- **Do not operate this BBQ indoors; the BBQ is for outdoor use only**
- **Do not obstruct any ventilation of the BBQ**
- **Do not light or operate with cover on**
- **Never store a spare LPG cylinder under or near your BBQ. This could cause excess pressure to be expelled through the relief valve resulting in fire, explosion, or severe personal injury including death**
- **LPG gas is heavier than air and will collect in low areas, proper ventilation is extremely important**
- **Keep the ventilation opening of the LPG cylinder enclosure free and clear from obstruction and debris**
- **Do not insert any foreign objects into the valve outlet. Damage may result, causing a leak, possible explosion, fire, severe bodily harm or death**
- **Children and adults should be alerted to the hazards of high surface temperature, burns and clothing ignition**
- **Never leave children unattended in the area where the BBQ is being used.**
- **Do not store items of interest to children around, below or in the shelf of the BBQ**
- **Never allow children to sit or stand on any part of the BBQ**
- **Some users prefer cooking on Hotplates. You must always have at least 1 Grill plate to ensure adequate air flow. Fully covering your BBQ will create a safety hazard.**

Always choose a safe location for the BBQ, keeping in mind the safety precautions outlined. Ensure all packaging has been removed from the unit before use.

NOTE

This BBQ shall only be used in an above ground open air situation with natural ventilation, without stagnant areas, where gas leakage and products of combustion are rapidly dispersed by wind and natural convection.

Any enclosure in which the BBQ is used shall comply with one of the following:

An enclosure with walls on all sides, but at least one permanent opening at ground level and no overhead cover. (Refer to Figure 1).

Within a partial enclosure that includes an overhead cover and no more than two walls. (Refer to Figure 2 and Figure 3).

Within a partial enclosure that includes an overhead cover and more than two walls, the following shall apply:

- At least 25% of the total wall area is completely open, (refer to Figure 4), and
- At least 30% of the remaining wall area is open and unrestricted, (refer to Figure 5)

In the case of balconies, at least 20% of the total wall area shall be and remain open and unrestricted.

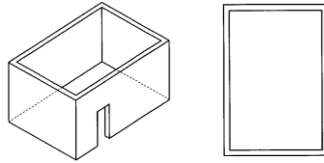

Figure 1 - Enclosure with walls on all sides but no overhead cover

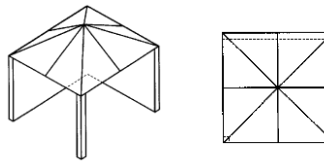

Figure 2 - Partial Enclosure with overhead cover and no more than two walls

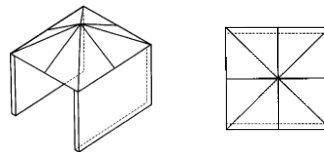

Figure 3 - Partial Enclosure with overhead cover and no more than two walls

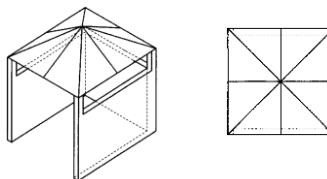

Figure 4 - Open side at least 25% of total wall area. 30% or more in total of the remaining wall area is open and unrestricted.

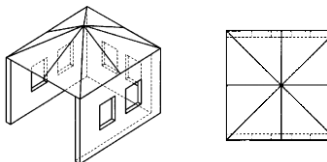

Figure 5 - Open side at least 25% of total wall area. 30% or more in total of the remaining wall area is open and unrestricted.

A strong gas smell or hissing sound of escaping gas indicates a serious problem with the BBQ or LPG cylinder. Failure to immediately follow the steps listed below could result in a fire or explosion that could cause serious injury, death or property damage.

- Shut off gas supply at cylinder
- Turn the control knobs of the BBQ to the off position
- Extinguish any open flame
- Open the BBQ hood
- Get away from the LPG cylinder
- Do not try and fix the problem yourself
- If gas odour continues or you cannot extinguish fire, call fire brigade

To prevent fire and smoke damage, remove all packaging material before operating BBQ.

HOSE ASSEMBLY AND SAFETY

A leak test (**Procedure located on Page 2 of this manual**) must be carried out prior to using the BBQ for the first time and each time the gas cylinder is refilled, or each time the gas hose and gas regulator have been disconnected. Check all gas hose and line connections for damage, cuts or cracks each time you use the BBQ.

If the hose shows signs of deterioration or damage, complete a leak test to identify any leaks and if required replace the hose.

The hose must remain free of kinks and sharp bends. Never puncture or put stress on the hose or fittings. Hose connection is located at the lower front area on the right side wall of the main body of the BBQ.

Replacement hose and regulators can be purchased from your local BBQ retail specialist. Leak Test procedure is located on Page 2 of this manual.

BURNERS

The location of the tube burner to the jet is vital for safe operation. Check to assure the jets are inside the burner tubes before using the gas BBQ

SPIDER AND INSECT WEBS

Some times spiders, ants and other insects climb into the tube burners, gas lines and other areas of the BBQ. The insects can spin webs, build nests and lay eggs. The webs or nests can be very small, but they are very strong and can block the flow of gas.



To avoid this occurring, clean burners prior to use, after storing, at the beginning of your BBQ season or after a period of one month with out use. Guards are on the air intakes in an effort to reduce this problem, but it will not eliminate it. An obstruction can result in a “flashback” (a fire in the burner tubes). The burner may still light, but the obstruction does not allow full gas flow to the burners.

NOTE: Complications arising from spider and insect webs built up inside gas lines are expressly excluded from Warranty



GAS CYLINDER INFORMATION

1. This BBQ is designed to be used with a gas cylinder not exceeding 9KG.
2. The gas cylinder supply valve must be turned off when the BBQ is not in use.
3. Gas cylinders must be stored outdoors, out of reach of children and must not be stored in a building, garage or any other enclosed area.
4. The gas cylinder used must incorporate a safety collar to protect the valve assembly.
5. Never store a spare cylinder under the BBQ shelves or inside the trolley housing. Any LPG cylinder not attached to the BBQ for use should be stored outdoors and well away from the BBQ.

IMPORTANT

1. When disconnecting and removing the gas cylinder for the purpose of refilling, always follow these procedures.
2. Ensure that all gas control valves on the BBQ and the gas cylinder are turned off before disconnecting the regulator from the cylinder.
3. Do not smoke or use a naked flame near the BBQ or gas cylinder while disconnecting the gas line between the BBQ and gas cylinder.
4. Remove the gas cylinder from the enclosure before disconnecting the regulator from the BBQ.
5. Tighten all connections before placing the gas cylinder back in to place.
6. The gas leak testing procedure should be conducted every time the gas cylinder is refilled and reconnected to the BBQ prior to using the BBQ (**Procedure located on Page 2 of this manual**).

Warning

For safe use of your BBQ and to avoid serious injury:

DO NOT let children operate or play near the BBQ.

KEEP BBQ area clear and free from materials that burn.

DO NOT block holes in bottom or back of BBQ.

Check burner flames regularly.

Use BBQ in well-ventilated space. NEVER use in enclosed spaces such as a carport, garage, porch, covered patio, etc.

DO NOT use charcoal or ceramic briquettes in a gas BBQ.



REGULATOR CONNECTION

1. Check that all control knobs are in the 'Off' position.
2. Make sure the cylinder valve is off.
3. Remove the protective cap from the cylinder, if present.
4. Leak test the connection with a soapy water solution (**Procedure located on Page 2 of this manual**)

NOTE

1. Never use a rusty or dented gas cylinder with a damaged gas valve
2. Never fill the gas cylinder beyond 80% capacity
3. Always have the gas cylinder filled by an authorized LPG supplier
4. If you have any questions concerning assembly or operation, consult your dealer or LPG Gas Company.
5. When used always place the BBQ and cylinder on flat level ground.
6. You will need to have the LPG cylinder serviced or replaced every ten years. The date of the last service should be stamped on the neck of the bottle.
7. Always use a spanner to tighten all gas fittings.

Standard POL Regulator

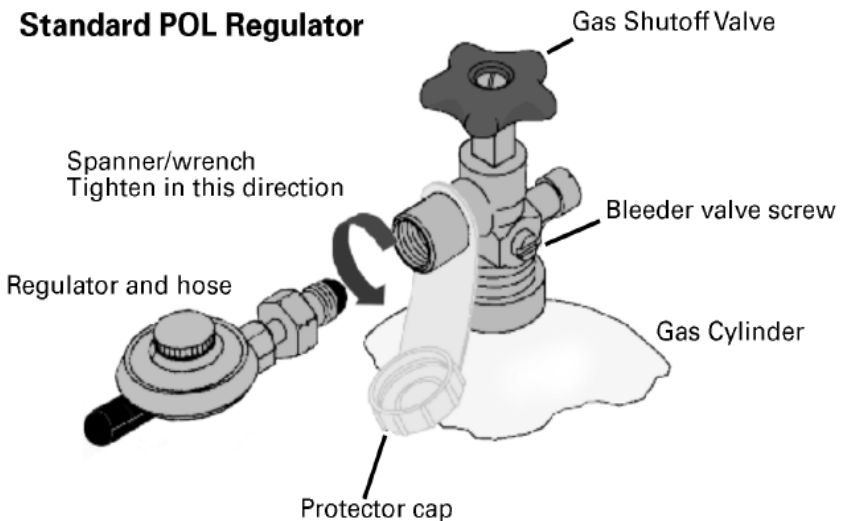

- Do not leave food unattended on the BBQ.
- In case of a fat fire turn gas off at cylinder immediately.
- Particular care must be taken when removing the fat drip tray. Hot fat can cause serious burn injuries.
- Proper clearance from combustible materials must be maintained at all times. The minimum clearances is as follows: Side: 700mm Rear: 700mm Ceiling: 1500mm
- Turn off all gas valves including cylinder after use.
- Do not allow build up of unburned gas.
- Cool the BBQ before replacing the lid or cover
- Accessible parts maybe very hot. Always keep children away from the BBQ
- Always wear protective gloves when handling hot components
- Never lean over BBQ when lighting
- Never use BBQ with any cover on
- Never dismantle control valves
- Never modify the construction of the BBQ or the size of any burner, injector orifice or any other components. This will void your Warranty.
- Never move the BBQ during use
- The use of unauthorised parts will void your Warranty and can create an unsafe environment and conditions of use.
- Never use charcoal or any other solid fuel in this BBQ
- Never disconnect any gas fittings while the BBQ is in use.
- In the event that a burner goes out and gas escapes, turn off the burner knobs, open the BBQ hood fully and let it air out. Wait 5 minutes before attempting to relight the BBQ.
- Never let clothing, pot holders or other flammable materials come in contact with or close to any grill, burner or hot surface until it has cooled. Fabric may ignite and result in personal injury. Certain materials or items, when stored under or near the BBQ, will be subjected to radiant heat and could be seriously damaged.
- Clothing or other combustible materials should not be hung from the BBQ, or placed on or near the BBQ. Combustible materials are considered to be wood, compressed paper, plant fibres, plastic or other materials capable of being ignited and burned

Parts Diagram

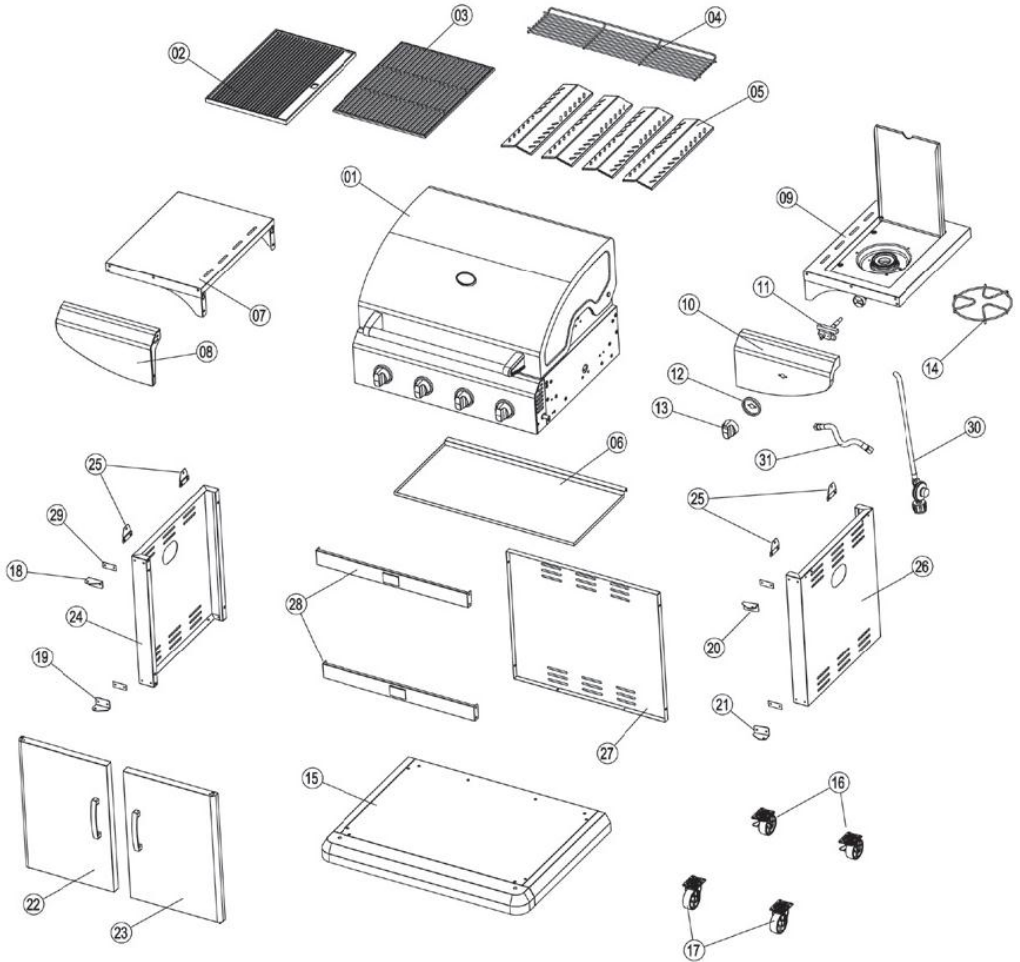

No. Part

- | | |
|-------------------------------------|------------------------------------|
| 1) 1x Hood | 16) 2x Locking Castors |
| 2) 1x Cooking Plate | 17) 2x Castors |
| 3) 1x Cooking Grill | 18) 1x Left Side Upper Hinge |
| 4) 1x Warming Rack | 19) 1x Left Side Lower Hinge |
| 5) 4x Flame Tamers | 20) 1x Right Side Upper Hinge |
| 6) 1x Drip Tray | 21) 1x Right Side Lower Hinge |
| 7) 1x Left Side Table | 22) 1x Left Side Door |
| 8) 1x Left Side Table Front Panel | 23) 1x Right Side Door |
| 9) 1x Side Burner | 24) 1x Left Side Panel of Cabinet |
| 10) 1x Right Side Table Front Panel | 25) 4x Firebox Mounting Plate |
| 11) 1x Side Burner Control Valve | 26) 1x Right Side Panel of Cabinet |
| 12) 5x Bezels | 27) 1x Back Panel |
| 13) 5x Control Knobs | 28) 2x Cabinet Crossbeam |
| 14) 1x Side Burner Trivet | 29) 4x Nut Panel |
| 15) 1x Cabinet Base | 30) 1x Regulator and Hose |
| | 31) 1x Side Burner Hose |

Screw Pack Contents

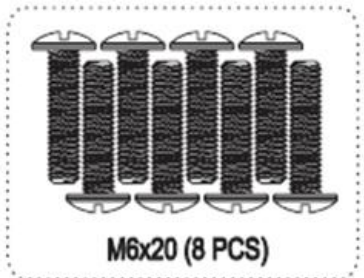
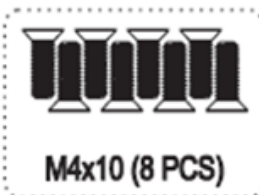
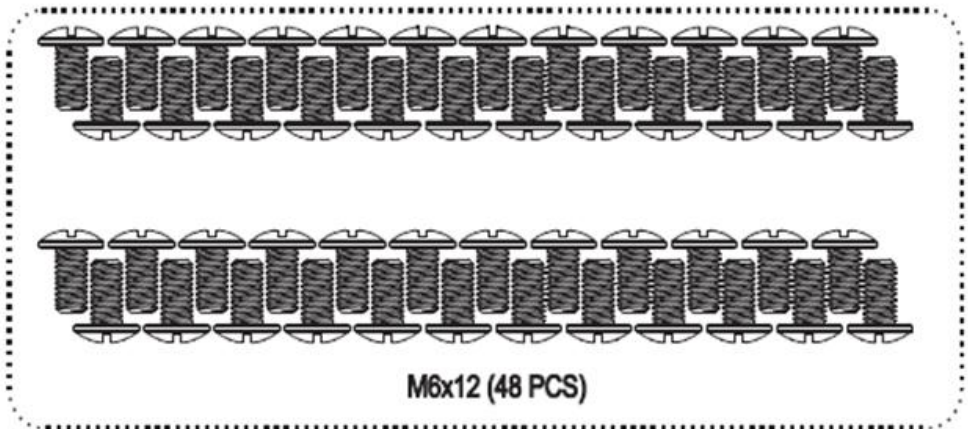

Assembly Procedure

Note: Tools required for assembly – Flathead Screwdriver, Hex nut Wrench

Step 1.

Fit Castors to the underside of the Cabinet base. The two Locking Castors should be attached to the rear of the BBQ. The two standard Castors should be attached to the front of the BBQ.

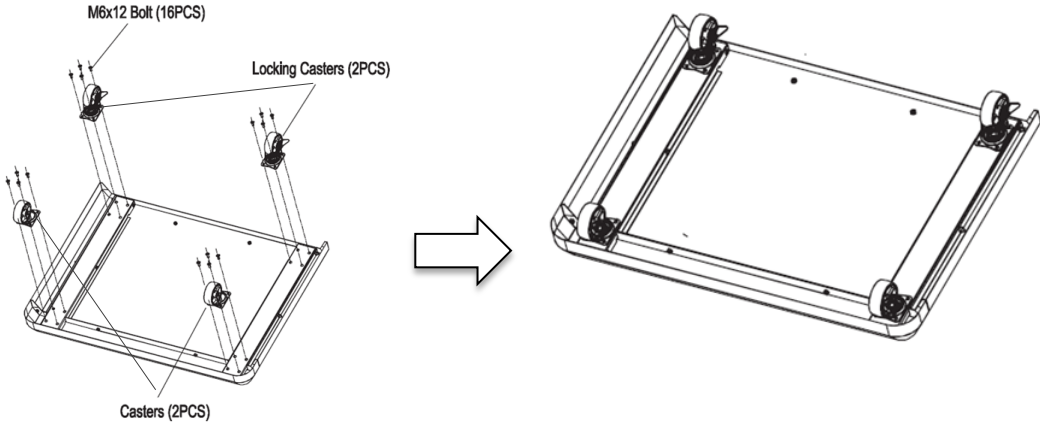

Step 2.

Turn the Cabinet base over and lock the two locking castors to continue assembling. Install Left and Right side panels.

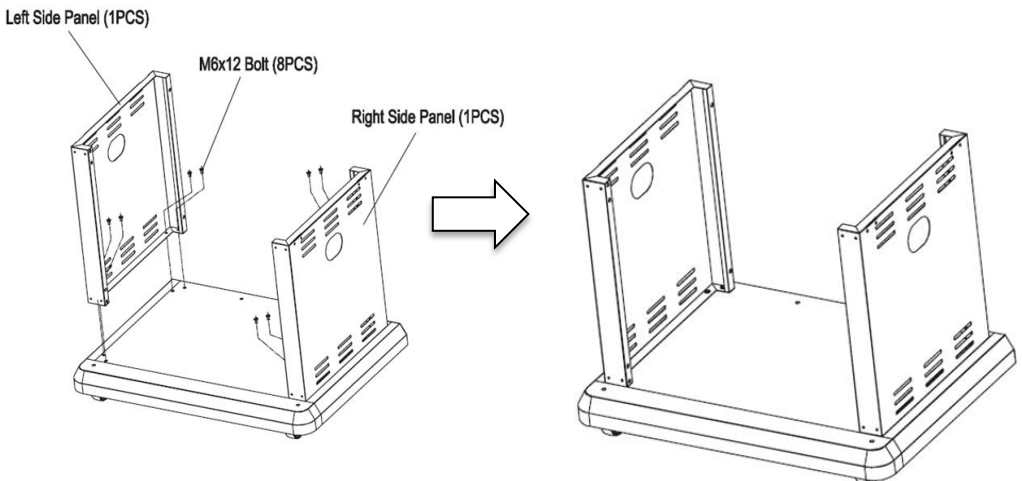

Assembly Procedure

Step 3.

Install Back Panel

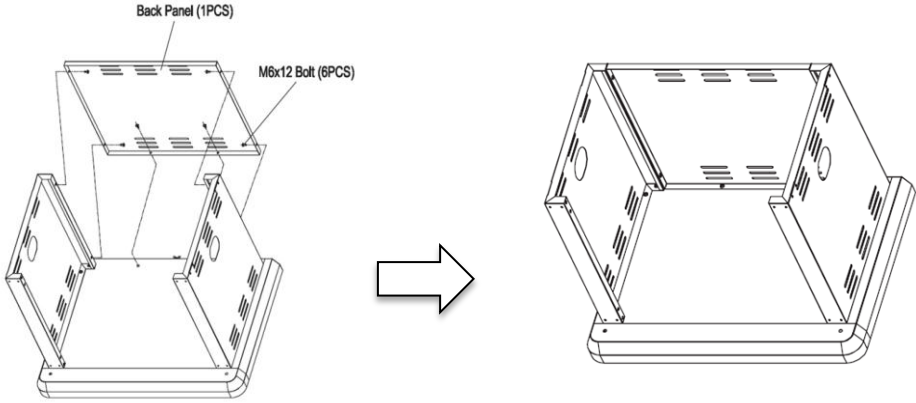

Step 4.

Install upper and lower Cabinet Crossbeams

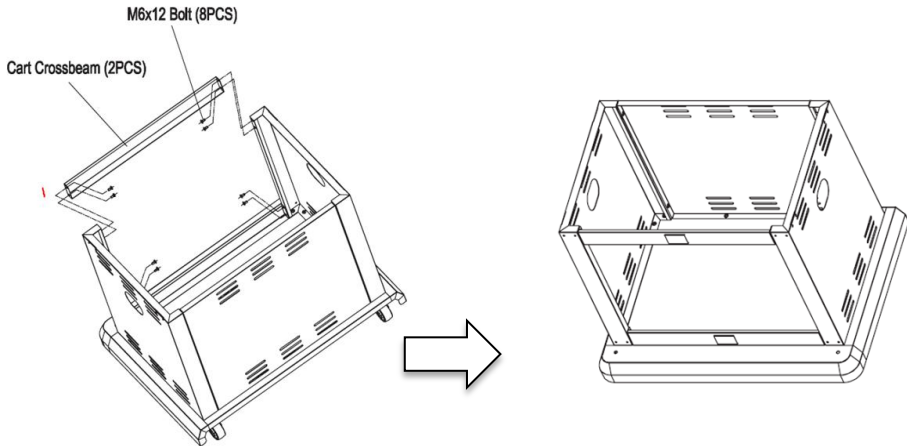

Assembly Procedure

Step 5.

Install Upper and Lower Left and Right Side Hinges

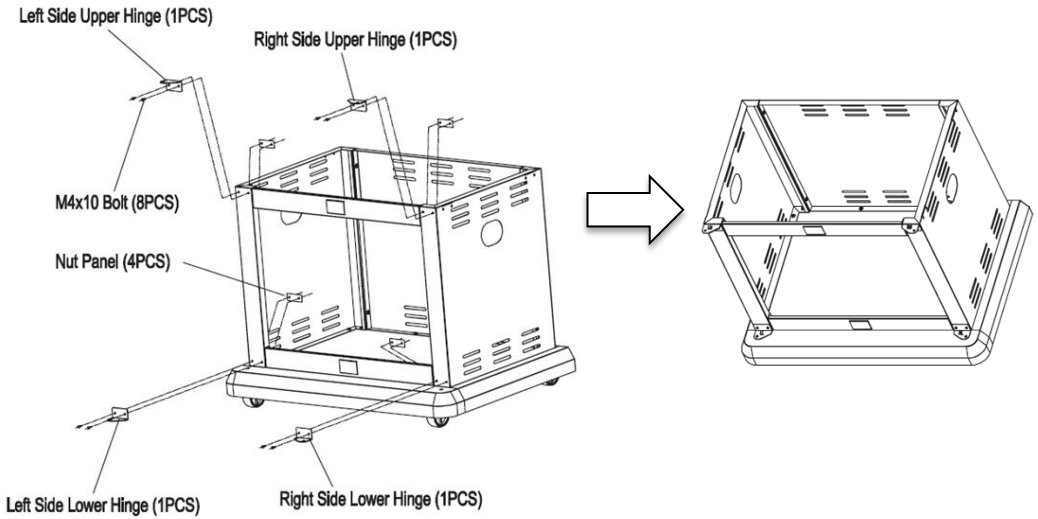

Step 6.

Install Left and Right Side Doors

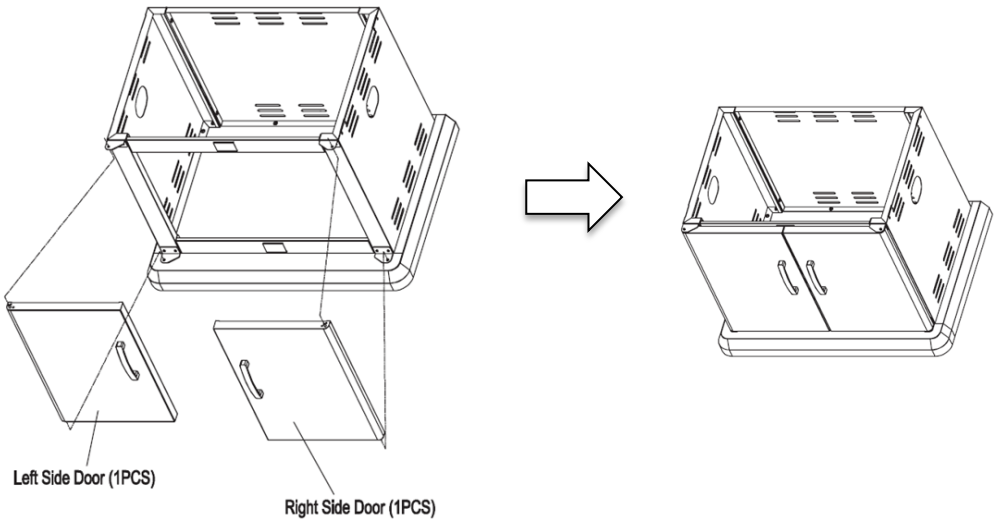

Assembly Procedure

Step 7.

Install Firebox Mounting Plates

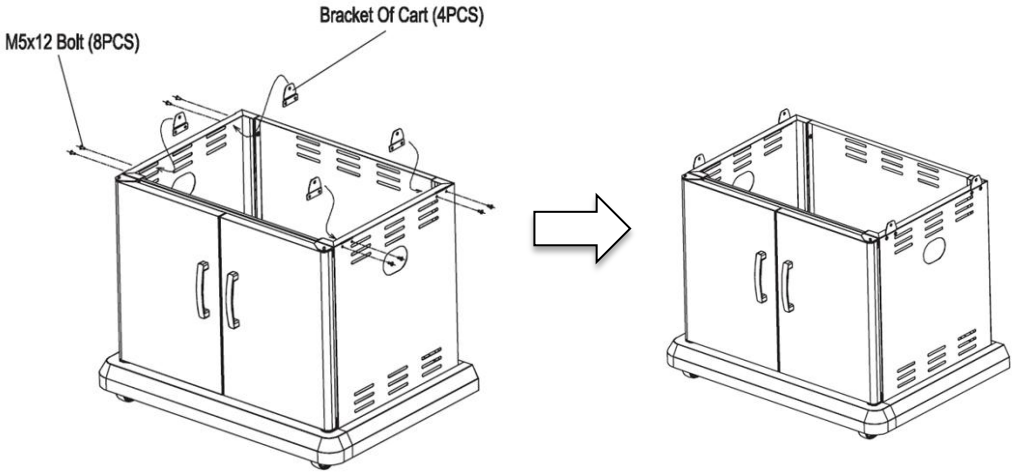

Step 8.

Lift Firebox into place on the Cabinet

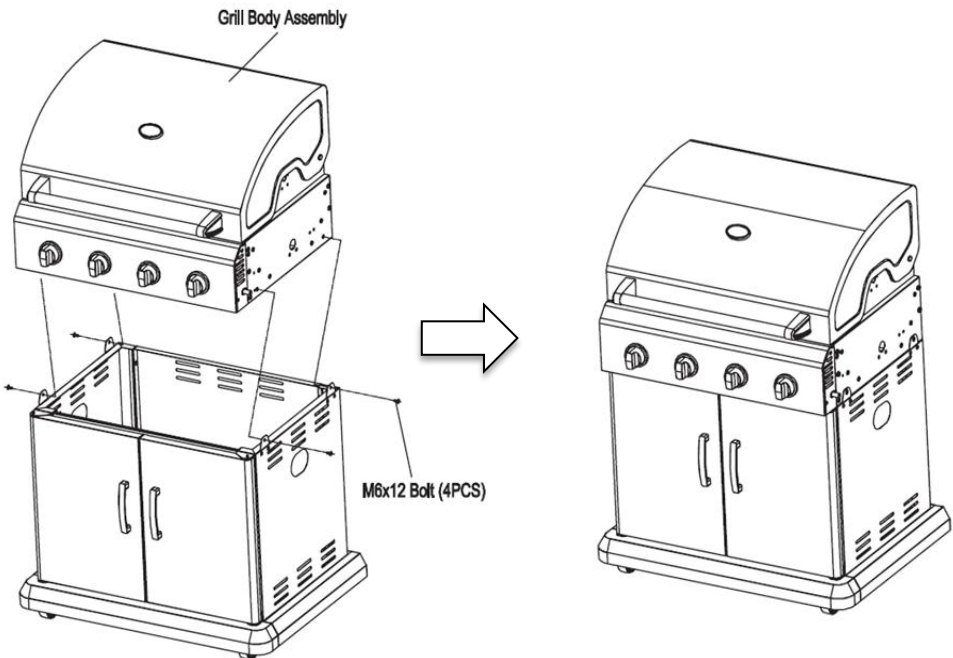

Assembly Procedure

Step 9.

Assemble Side burner and Left side table.

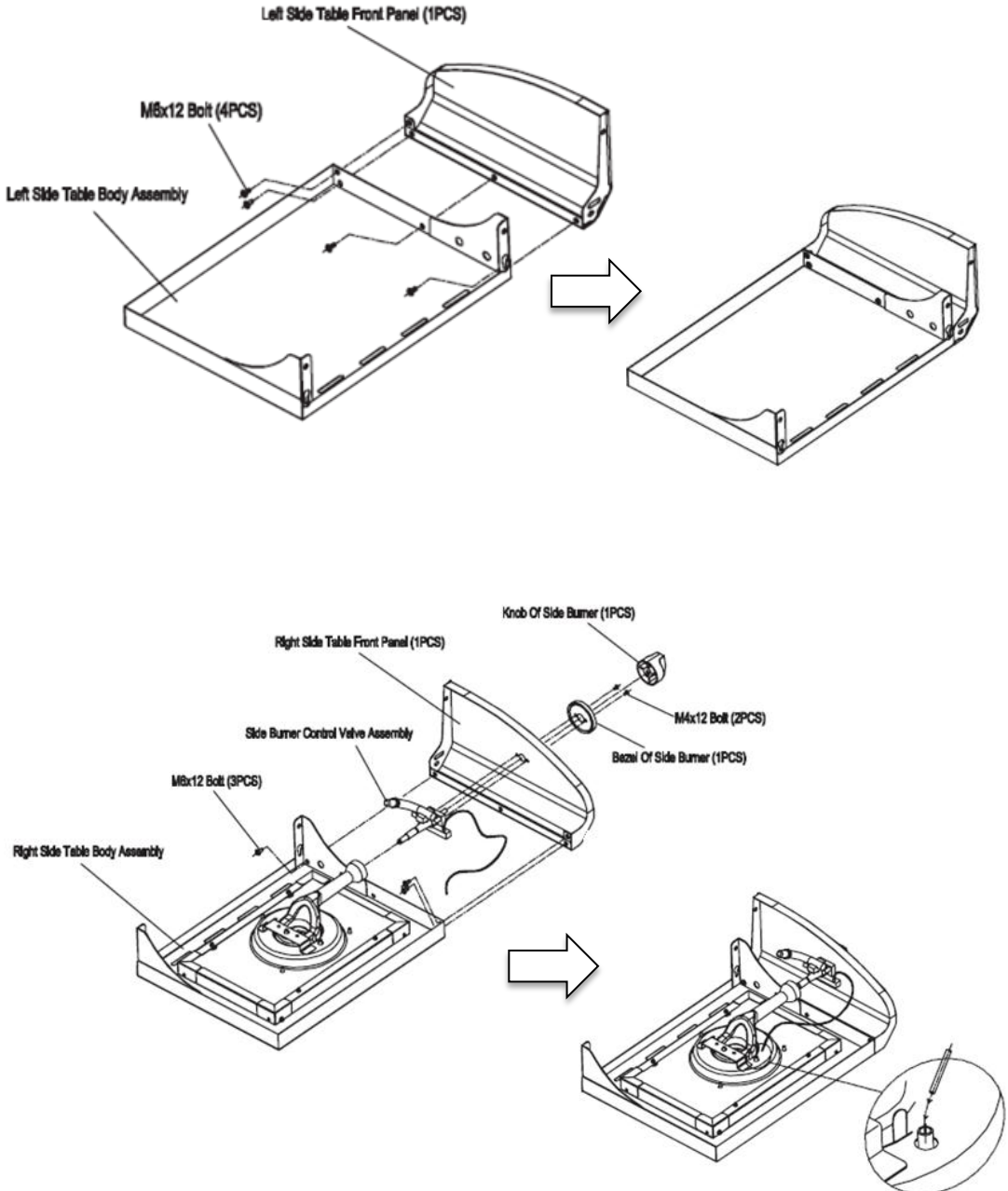

Assembly Procedure

Step 10.

Install Side burner and Left side table. Note that the Side burner is on the Right hand side of your BBQ

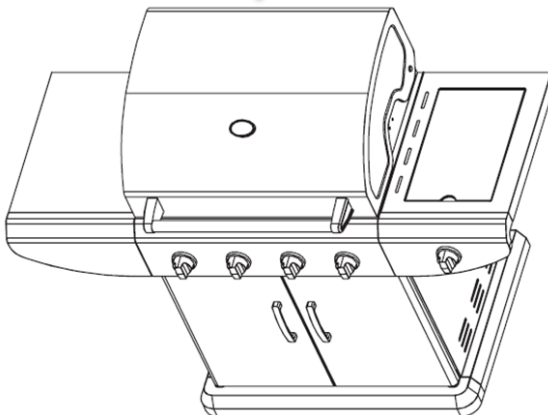
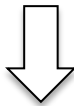
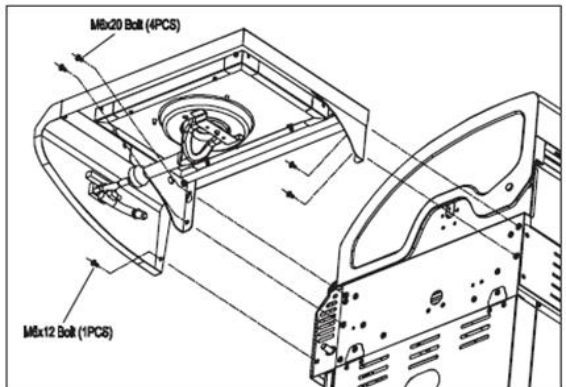
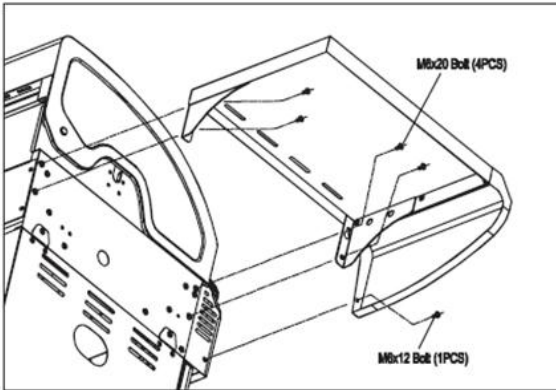

Assembly Procedure

Step 11.

Insert the Flame Tamers, then Cooking Plate, Cooking Grill and Warming Rack. Insert Side Burner Trivet.

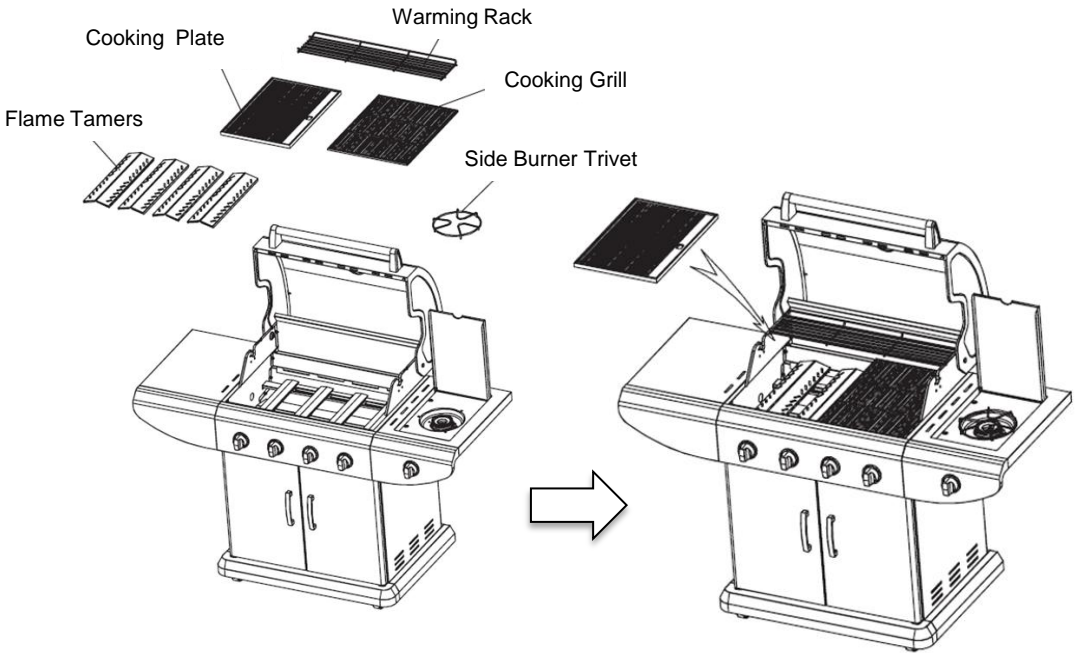

Step 12.

Insert Drip Tray into the back of the BBQ

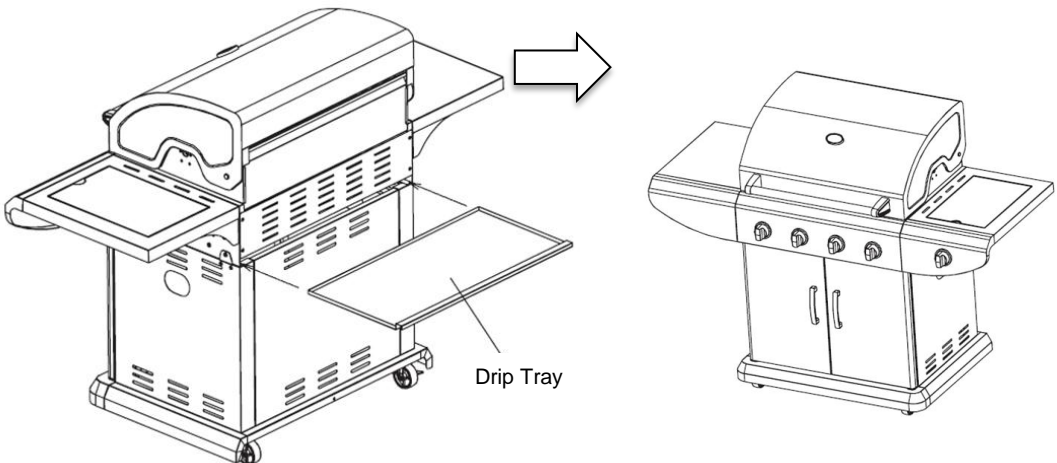

Step 13.

A Goldair Universal Rotisserie is not supplied with this BBQ but can be purchased separately from your local BBQ Retailer. To Install the Goldair Universal Rotisserie install the 2x support brackets with adjustable slides on either side of burner box to gain the height for the Rotisserie

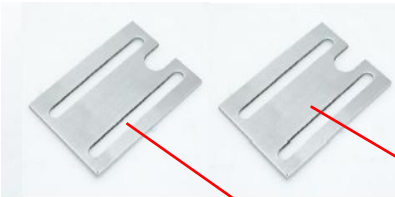

2 pcs Support Bracket



Step 14.

The BBQ is intended to be used with a standard 9kg LPG cylinder. This is the type of cylinder that can be refilled at petrol station or swapped for similar cylinder.

Place the cylinder in position under the left hand side burner, so that cylinder sits flush on the ground.

Take the hose that came with the BBQ, check that it has a rubber seal on the regulator end of the hose and connect this end to the gas cylinder, ensuring that the hose is not twisted. You won't need a spanner here. Just turn the fitting in an anti clockwise direction and hand tighten as much as you can. This should seal it sufficiently.

It is important to conduct a leak test prior to use. Follow leak test procedure. (Procedure located on Page 2 of this manual)

Important: The hose must not be kinked.

- Never leave burners on high for more than 10 minutes unless actually cooking. If the burner makes hissing sounds when lit, it may be burning inside. Turn burner off, allow it to cool and try again.
- Close the gas cylinder valve after each use.
- Never use plastic or glass utensils on the BBQ
- Never use the BBQ in strong winds
- Never lay the gas cylinder down (always keep upright)
- Never allow the flexible gas supply hose or any electrical cord to come in contact with any heated surface of the BBQ.
- Never lean heavily on the side shelves of your BBQ or attempt to transport your BBQ by lifting it from the side shelves.
- Before you start cooking for the first time, clean the BBQ thoroughly with hot soapy water. This is necessary to remove residuals and solvents, oil and grease, which may have remained from the manufacturing process. The hotplate and grill should be thoroughly cleaned in the same manner.

Lighting the BBQ

Lighting the BBQ is easy, but must be done with due care.

Make sure that the gas is turned on at the cylinder, or that gas is available to the BBQ. Also, if your BBQ has a roasting hood, ensure that the hood is up.

Spark Ignition

Push the knob control in and turn anticlockwise to the high position. You should hear clicking as the ignitor creates sparks to light the gas. Once lit, release the ignitor button.

Manual Ignition

You can light your BBQ manually by holding a lit match next to one of the burners using the match holder, while the burner is on low. You can access the burners through the grill of your BBQ with the match holder.

Difficulty lighting

If the burner doesn't light first go, check the gas controls and try a couple more times. If the burner still does not light, wait a few minutes to allow the gas to disperse before trying again. If satisfactory operation cannot be achieved, consult your retailer before proceeding.

Note: Failure to follow the lighting procedures correctly can lead to a hazardous condition.

Controlling the flames

The knobs have three basic positions: Off, High and Low. You can achieve any flame height between low and high by rotating the BBQ control knob between these positions.

Checking the flame

Look underneath the BBQ so that you can see the flames. They should be a soft blue colour with yellow tips. If the flames are too yellow, there is too much gas and not enough air. The flame will be inefficient and will give off too much smoke. If the flame is too pale, there is too much air and not enough gas. If either of these situations occur you may need to clean the burners (See 'Maintenance' section of this manual).

Note: 'Blowback' is a situation where the flame burns inside the burner, towards the front. It can be recognised by a sharp roaring sound coming from the burner. It is not dangerous unless it is allowed to persist. If this occurs, simply turn the burner off, wait a few seconds then relight.

Before first use - Curing the cast iron

During manufacturing, the cooking surfaces (plates and grills) were coated with a non-toxic paint. This paint will come off completely over time. Its purpose is to help protect your BBQ during transport and storage. Coat the top of the hotplates and grills with canola oil or something similar. Light the BBQ as described earlier. Leave the BBQ with all burners on low for about 30 minutes. Paint may come off at this time.

Now clean the surfaces with water and a brush.

Be careful of steam coming off the cast iron surface while doing this. The hotplates and grills are now cured and ready for use. This process only needs to be done the first time you use the BBQ.

For on-going protection of the cooking surfaces, follow the procedures in the 'Maintenance' section of this manual.

Controlling flare up

Flare-ups are sudden bursts of flame that come up over the top of the grill. They are caused by natural cooking juices from your food falling onto the flame tamer and then burning.

A little bit of flare-up, as well as the resulting smoke, is a good thing. It's what gives BBQ'd food that unique outdoor flavour. But if it happens too often, or if the flame last more than a couple of seconds, your food will char, so you need to control it.

First of all, cooking very fatty foods will cause a lot of flare up. You should trim excess fat off your meat. Also, excess flaring usually means your controls are up too high. Try turning them down.

Finally, moving the meat away from flaring will help reduce the problem. Some really fatty foods can only be cooked on the hotplate.

Turning off

When you've finished cooking, leave the burner controls on high for a maximum of 5 minutes to burn off excess grease from the flame tamer, the burner and other surfaces. To turn the BBQ off, it is best to turn the cylinder off first, and allow the gas left in the hose to burn off. This will only take a couple of seconds. Then turn off all burner controls. If your BBQ is connected to piped LPG, you can simply turn the burner controls off. It's okay to leave the cylinder connected to your BBQ while it's not in use.

Note: Failure to follow these shutdown procedures correctly can lead to a hazardous condition.



Avoid burning or charring food as this has been shown to be unhealthy.

Don't leave cooked food standing for too long before eating.

Keeping your food moist

It's easy to keep food moist and succulent on a BBQ by following these guidelines:

- Use tongs instead of a fork when turning meat and poultry. A fork pierces the flesh and causes the juice to seep out.
- Resist the temptation to keep turning meat over. Juices tend to rise to the top of a piece of meat, then settle. Each time you turn the meat over, the juices are lost. It's better to quickly sear the meat on both sides (about half a minute) then with the burner controls down low, leave the meat cook on one side, turning only once before serving.
- If you like salt with your food, try adding it at the end instead of before or during cooking. Salt draws the natural moisture out of the food and dries it out.
- Baste the food with light marinade or canola oil a couple of times while cooking, though watch out for excessive flare-up.

How covered cooking works

Place the food you wish to roast on one side of the BBQ. Turn on the burners that are not directly underneath the food. Make sure the burners that are directly under the food are turned off. This way the food receives no direct heat.

Moist, hot air rises from the burners and circulates around the food, trapping the juices and flavour.

Best results are achieved by using a roasting rack and drip pan.

Cooking times

Keeping the hood closed traps the heat, moisture and flavour that is normally lost on an open top BBQ. The result is that food cooks considerably faster, using less gas, and with a juicier, more even finish. Foods require less attention and less basting because the heat is less intense and moisture is more easily retained.

Grilling

Food may be cooked in about 3/4 the usual time, producing well browned surfaces while still maintaining the foods natural juices.

Roasting

Larger joint of meat achieve similar results as in a conventional oven, except in about 2/3 the usual cooking time due to the natural convection effect created by the hood.

Rotisserie

This method of cooking is terrific, producing moist, evenly cooked meats and poultry in about 2/3 the usual cooking time.

Do not allow the temperature to exceed 250°C.

Approximate Cooking Times:

Beef 30–50 minutes per kg

Lamb 40–50 minutes per kg

Veal 40–50 minutes per kg

Pork 50–60 minutes per kg

Poultry 40–45 minutes per kg

Fish 30–40 minutes per kg

Times will vary depending on size and shape of meat, initial temperature, and how well you like your meat cooked.

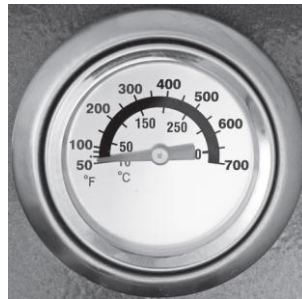

Tips

Although cooking on the plate looks easier, cooking on the Grill gives you a more authentic BBQ flavour. Natural juices drip onto the flame tamer then vaporise, with the vapors penetrating back into the food.

As an alternative to simply grilling, try marinating your meat, fish, poultry or vegetables first. The longer you leave the food to stand in the marinade, the more thoroughly the flavour will soak through. Several pre-made marinades are available and good recipes are easy to come by. It is best to leave food standing in the refrigerator.

If you use a tomato or sugar based sauce for basting, apply it in the last 5–10 minutes of cooking. Using these sauces over a longer period of time will result in over-browning.

To prevent meat from curling, slash the remaining fat at roughly 5cm intervals, taking care not to cut into the meat.

- Do not perform any repair or servicing on the BBQ yourself. This includes internal adjustment of the regulator and gas valves. This must only be carried out by authorised technicians. Your BBQ should be serviced annually by a certified gas service agent.
- Clean the drip tray regularly.
- “Burning off” the BBQ after every use (for approx 15 minutes) will keep excessive food residue to a minimum.
- The pressure regulator and hose assembly supplied with the BBQ must be used. Replacement pressure regulator and hose assembly must be those specified by the manufacturer. Replacement parts may be obtained from the manufacturer or your local BBQ retail specialist.
- Storage of this BBQ indoors is permissible only if the cylinder is disconnected and removed from the BBQ.
- Please note that the Goldair BBQ Cover (**if supplied with this model**) is not covered under your Warranty. The BBQ is for portable outdoor use and is not intended for permanent installation or installation in vehicles or boats.

Storing your BBQ

Your BBQ is designed to be used outdoors. However, just like a car, you will prolong the life of the BBQ if you store it out of direct exposure to the elements when not in use. This can be done in many ways including the use of a waterproof cover. These are available from most BBQ retailers.

BBQ Covers

All BBQ's must be stored with a BBQ cover when not in use (regardless of whether the BBQ is stainless steel or powder coated) as per the Warranty. After use, allow your BBQ to cool completely before fitting the cover (the BBQ cover may melt or burn if placed onto a hot BBQ). Also condensation can occur when the BBQ cools down under the cover which can foster rust growth. Please note, a cover can foster a “micro-environment” where moisture, salts and fat deposits can develop when stored for long periods of time (typically this will occur during the Winter months when your BBQ is not used). During these longer periods of non-use a BBQ can develop stains and/or rust marks. It is important to check regularly (monthly) for any signs of these stains/rust and clean if needed. If surface stains and rust are left, over time they develop and can become very hard to remove, this is expressly excluded from your Warranty.

- Move the BBQ to a covered location. If you are storing it in a closed room (eg shed or garage) you should keep the cylinder away from any other cylinders or any cars, boats, motorcycles or any other petrol engines.
- If you don't intend to use it for a few months, lightly spray all the surfaces with canola oil. This will help protect against corrosion.

Rust on your BBQ from lack of protective agents or misuse are expressly excluded from Warranty.

On-going Maintenance

Your BBQ requires regular maintenance (interior and exterior). The use on a BBQ cover in conjunction with the instructions below will help to ensure it remains in proper working order and maintains its appearance.

Exterior:

Stainless Steel BBQ's

Overtime grease, fat and other cooking oils may build up on your BBQ. To clean, wash with warm/hot soapy water. Wash off soapy water with warm/hot clean water, leave to air dry. Apply a stainless steel BBQ protector to stainless steel surfaces. This will apply a protective coating on the exterior of the BBQ and assist in repelling the elements.

Stainless steel will rust if you do not look after it properly.

From time to time spotting may occur on the exterior of your BBQ. This is normal and is due to moisture and/or other elements becoming trapped under the cover of your BBQ and building up (it is highly recommended that all BBQ's are stored under an eave with a cover to protect against the harsh New Zealand elements – any BBQ not stored and covered correctly will not be covered under Warranty). To ensure that spotting and discoloration does not become worse and more visible resulting in permanent damage to your BBQ, it should be cleaned and removed straight away. This is best done with a stainless steel cleaner/cutback solution, or if the spotting is larger and harder to remove, use a stainless steel/metal polish and then a cleaner/solution. Always use a soft cloth to clean your BBQ.

Never use abrasive heavy duty sponges or scouring pads on the exterior of your BBQ, these products will begin to remove the stainless steel finish resulting in an uneven surface and faster rusting in the future.

Powder Coated BBQ's

Overtime grease, fat and other cooking oils may build up on your BBQ. To clean, wash with warm/hot soapy water. Wash off soapy water with warm/hot clean water, leave to air dry. Once dry, use a BBQ exterior cleaner, this will apply a protective coating on the exterior of the BBQ and assist in repelling the elements. Always you use a soft cloth to clean your BBQ.

Never use abrasive heavy duty sponges or scouring pads on the exterior of your BBQ, these products will begin to remove the powder coated finish resulting in an uneven surface and may result in rusting in the future.

On-going Maintenance

Interior:

Plates and Grills

The best way to clean your BBQ plates/grills is to light-up the BBQ and leave it on with the hood down to warm-up for 10-15 minutes. After this time, remove excess fat, oils, cooking residue with paper towels or a cotton rag from plates/grills then take a long handled brush and a scraper and remove remaining oil and food scraps. You should use an oven mitt to avoid burning yourself This can also be completed after each time you use your BBQ.

Depending on how often you use your BBQ you should also wash your plates/grills bi-monthly. After you have completed the steps above and have allowed time for the BBQ to cool, remove the plates/grills and wash with warm/hot soapy water. Wash off soapy water with warm/hot clean water, leave to air dry and place back into BBQ.

Warming Rack, Flame Tamers

Remove and wash with warm/hot soapy water. Wash off soapy water with warm/hot clean water, leave to air dry and place back into BBQ. For stubborn stains on your warming rack, soak in hot soapy water.

The Drip Tray

Your BBQ is equipped with a two stage fat drainage system. Food residue drops onto the main tray, then falls through the centre hole into the drip cup.

It is a good idea to line the fat tray with aluminium foil to assist with cleaning.

Ensure there is a hole in the foil to allow fats and oils to drip through into the drip cup below. Also, placing absorbent material into the drip tray will avoid splashing and overflowing when the container starts to fill. Suitable absorbent material is available from your retailer. You should change the fat absorbent material regularly. in your drip tray, also, keep the main fat tray itself clean to prevent a build up of grease. If you don't do this a fat fire can result. This can be quite dangerous, and will certainly void the Warranty on your BBQ.

Burners

Over time fat, marinades, juices, etc. can build-up and cover the port holes in your burners. This reduces gas and flame flow and may result in fires within the BBQ during cooking. Leaving the burners on for a maximum of 5 minutes with the hood open after you've finished cooking will remove most of this. However, you should check the burners periodically for any sort of blockage. In particular, you should ensure that the aeration vents are free of insect nests and spider webs. To clean the burners, let them cool down, then remove and inspect them. If any of the holes are clogged, gently tap the burner onto a hard surface to remove residue. Use a wire brush to unclog the holes. Then lightly coat the burners with canola oil for on-going protection

Troubleshooting

Problem	Possible Cause	Prevention/Solution
Burner(s) will not light using ignition.	Wire and/or electrode covered with cooking residue. Electrode cracked or broken "sparks at crack". Electrode tip not in proper position. Wires are loose or disconnected. Wires are shorting (sparking) between ignition and electrode. Dead battery.	Clean wire and/or electrode with rubbing alcohol and clean swab. Replace electrode(s). Reconnect wires or replace electrode/wire assembly. Replace ignition wire/electrode assembly. Replace with a new AA battery.
Burner(s) will not Light using match stick.	No gas flow. Coupling nut and regulator not fully connected. Obstruction of gas flow. Disengagement of burner to valve. Is grill assembled correctly?	Check to see if LPG tank is empty. If LPG tank is not empty, refer to " <i>Sudden drop in gas flow</i> ". Turn the coupling nut until solid stop. Clear burner tube(s). Reengage burner and valve. Check steps in assembly instructions.
Sudden drop in gas flow or low flame.	Out of gas. Excess flow valve tripped.	Check for gas in LPG tank. Turn off knobs, wait 30 seconds and light grill. If flames are still low, turn off knobs and LPG tank valve. Disconnect regulator. Reconnect regulator and leak test (Procedure located on Page 2 of this manual). Turn on LPG tank valve, wait 30 seconds and then light grill.
Flames blow out.	High or gusting winds. Low on LPG gas. Excess flow valve tripped.	Turn front of grill to face wind or increase flame height. Refill LPG tank. Refer to " <i>Sudden drop in gas flow</i> " above.
Flare-up.	Grease buildup. Excessive fat in meat. Excessive cooking temperature.	Clean grill. Trim fat from meat before grilling. Adjust (lower) temperature accordingly.
Persistent grease fire.	Grease trapped by food buildup around burner system.	Turn knobs to OFF. Turn gas off at LPG tank. Leave lid in position and let fire burn out. After grill cools, remove and clean all parts.
Flashback (fire in burner tube(s)).	Burner and/or burner tubes are blocked.	Turn knobs to OFF. Clean burner and/or burner tubes.

Troubleshooting-Electronic Ignition

Problem	Possible Cause	Check Procedure	Prevention/Solution
No sparks appear at any electrodes when ignition button is pushed; no noise can be heard from spark module.	Not installed properly.	Check battery orientation	Install battery (make sure that "+" and "-" connectors are oriented correctly, with "+" end up and "-" end down.
	Dead battery	Has battery been used previously?	Replace battery with new AA-size alkaline battery.
	Button assembly not installed properly.	Check to ensure threads are properly engaged. Button should travel up and down without binding.	Unscrew button cap assembly and reinstall, making sure threads are aligned and engaged fully.
	Faulty spark module.	If no sparks are generated with new battery and good wire connections, module is faulty.	Replace spark module assembly.
No sparks appear at any electrodes when ignition switch is pushed; noise can be heard from spark module.	Output lead connections not completed.	Are output connections on and tight?	Remove and reconnect all output connections at module and electrodes.
Sparks are present but not at all electrodes and/or not at full strength.	Output lead connections not complete.	Are output connections on and tight?	Remove and reconnect all output connections at module and electrodes.
	Arcing to grill away from burner(s)	If possible, observe grill in dark location. Operate ignition system and look for arcing between output wires and grill flames.	If sparks are observed other than from burner(s), wire insulation maybe damaged. Replace wires.
	Weak battery	All sparks present but weak or at slow rate.	Replace battery with a new AA-size alkaline battery.
	Electrodes are wet	Has moisture accumulated on electrode and/or in burner ports?	Use paper towel to remove moisture.
	Electrodes cracked or broken "sparks at crack"	Inspect electrodes for cracks.	Replace cracked or broken electrodes.

GOLDAIR

One Year Warranty

Your Goldair product has been inspected, tested and is guaranteed subject to the following for a period to one year from the date of purchase against defects in workmanship and materials. During this period, such defects will be rectified by repair or replacement of the product purchased. Your Warranty becomes invalid if in our opinion the product has been misused, incorrectly assembled, tampered with, connected to a gas supply not corresponding with the name plate specification, stored outdoors without the use of a BBQ cover and exposed to the elements or not regularly maintained as per the "Maintenance" notes at the end of this user manual. The Warranty does not include any labour or other associated expense that may be involved in removal or installation of the product. Normal wear & tear and any issues involving spider/insect web build up's inside gas lines are expressly excluded.

If your Goldair product fails to operate satisfactorily, please contact Goldair via phone in the first instance. To obtain a repair or replacement product under this Warranty, you will need to produce satisfactory evidence of date of purchase. The completed Warranty and purchase receipt must be presented with the product. The Warranty should be filled out at the time of purchase. It is in your interest to make sure this is done.

Please note, BBQ covers (if included) are not covered under the Warranty.

If the product is to be replaced (cannot be repaired) then that replacement will be of the same or similar product or accessory excluding packaging, instruction card etc. Where a replacement product is supplied, this shall be guaranteed for the balance of the original Warranty period.

Any model that is no longer available will be replaced by a model of a value and with such features as we consider appropriate in the circumstances. Goldair Ltd is not responsible for freight forwarding charges, losses or damage in transit.

If service is required after the Warranty period has expired, the product should be inspected by a qualified gas service technician. Service outside of the Warranty period will be at your cost.

Consumers Guarantee Act (1993).

In accordance with the above act, consumers are advised that: The manufacturer does not undertake that repair facilities and parts are necessarily available for this product.

If any of the provisions of the foregoing are contrary to any relevant legislation, then that provision shall be deemed to be excluded from the Warranty and the rest of the provisions will continue to apply.

IMPORTANT: Please retain this Warranty card

Name Purchased from

Address Date of purchase

..... Name of product

Suburb Model no

TECHNICAL SPECIFICATION

Model No: GBQMT1

Gas Type: LPG

Injector Size: 0.85mm for Main, 0.89mm for Side

Total Gas Consumption: 15.5 kW/h

Gas Pressure: 3.0 kPa

GOLDAIR

SUPPORT AND TECHNICAL ADVICE

PO Box 100707, NSMC, Auckland, New Zealand

Monday – Friday 8am-5pm

Phone: 0800 232 633

Website: www.goldair.co.nz