

**IP Box Camera  
ACM-5711**

Ver. 081016

**Hardware User's Manual**



[www.acti.com](http://www.acti.com)

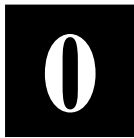

# PRECAUTIONS

## 1. Read these instructions

All the safety and operating instructions should be read before the product is operated.

## 2. Heed all warnings

All warnings on the product and in the instruction manual should be adhered to.



The symbol indicates the following items, please carefully read the description next to each symbol.

- a. Failure to follow the safety instruction given may directly endanger people, cause damage to the system or to other equipment.
- b. The requirements to make this device work, including hardware, computer settings, network settings, and operation procedures.
- c. The tips to make using this device easier, more convenient and more efficient.

## 3. Servicing

Do not attempt to service this video product yourself as opening or removing covers may expose you to dangerous voltage or other hazards. Refer all servicing to qualified service personnel.

## Trademarks

All names used in this manual for hardware and software are probably registered trademarks of respective companies.

## Liability

Every care has been taken during writing this manual. Please inform your local office if you find any inaccuracies or omissions. We cannot be held responsible for any typographical or technical errors and reserve the right to make changes to the product and manuals without prior notice.

## FCC/CE Regulation

NOTE: This equipment has been tested and found to comply with the limits for a Class A digital device, pursuant to Part 15 of the FCC Rules. These limits are designed to provide reasonable protection against harmful interference when the equipment is operated in a commercial environment. This equipment generates, uses,

and can radiate radio frequency energy and, if not installed and used in accordance with the instruction manual, may cause harmful interference to radio communications. Operation of this equipment in a residential area is likely to cause harmful interference in which case the user will be required to correct the interference at his own expense.

# Table of Contents

<b>0</b>	<b><i>PRECAUTIONS</i></b>	<b><i>0-1</i></b>
	Trademarks	0-1
	Liability	0-1
	FCC/CE Regulation	0-1
<b>1</b>	<b><i>INTRODUCTION</i></b>	<b><i>1-1</i></b>
<b>1.1</b>	<b>Package Contents</b>	<b>1-1</b>
<b>1.2</b>	<b>Features and Benefits</b>	<b>1-2</b>
<b>1.3</b>	<b>Safety Instructions</b>	<b>1-4</b>
<b>1.4</b>	<b>Physical Description</b>	<b>1-6</b>
<b>1.5</b>	<b>Basic Connections</b>	<b>1-10</b>
<b>1.6</b>	<b>Product Specification</b>	<b>1-11</b>

# 1

## INTRODUCTION

### 1.1 Package Contents

ACM-5711



Power Adaptor (Option)



Product CD



Terminal Blocks for Power & DI/O



Warranty Card



Accessory



## 1.2 Features and Benefits

This IP device is a cutting-edge digital video transmission device. It can compress and transmit real time images with outstanding images quality (D1, 720x480) at reasonable bandwidth through a standard TCP/IP network. That is because it is Ethernet ready and has the powerful ARM9 SoC with excellent system performance to offer dual streams of MPEG4/MJPEG, and both formats offer megapixel resolution. In addition, with these powerful hardware platform, excellent SDK support and powerful respective apparatuses (e.g. the transcoder), this IP device is your best choice building up either conventional IP surveillance system or intelligent IP surveillance system.

- **MPEG-4/MJPEG Dual Streaming**

With excellent system performance, MPEG-4/MJPEG are supported. It brings superior image quality not only 30 frame per second in full D1 resolution.

- **Digital Time Code Embedded**

The “Digital Time Code Embedded” function is to embed the recording time in the MPEG bit stream. Therefore, each image frame has its respective time when it was recorded. It is very useful when users want to find the video at an exact time or between a certain time intervals.

- **DDNS Supported**

This IP device supports DDNS (Dynamic Domain Name Server), users can set this IP device at a virtual domain name (such as cam1.Taipei.xxx) at dynamic IP. Everyone can use the virtual domain name to view the video anywhere that has the access to the internet.

- **Build-in Hardware Motion Detection**

No more external motion sensors are required. Each IP device can be set up to 3 detection areas. By tuning the object size and sensitivity, it is very reliable to fit into your environment. Besides, hardware motion detection delivers better sensitivity and responds faster than software motion detection.

- **Bundle Powerful Surveillance Software**

To extend the capabilities of the IP outdoor rugged dome series, a powerful surveillance program is included in the package and is very free

to use. Users can easily utilize the existing PC to be a digital video recorder. Schedule recording and manual recording keep every important image recorded in the local hard disk. Reliable and accurate motion detection with instant warning makes you responsive in every condition. Quick and simple search and playback function lets you easily find the images you want.

- **Software Development Kit Support**

This IP device can be integrated or controlled by user's application program through the Streaming Library or ActiveX control. With its high level programming interface, software developer's time and efforts to is highly reduced.

## 1.3 Safety Instructions

- **Don't use the power supply with other voltages**

This device is likely to be damaged or damage other equipments / personnel, if you use a power supply with different voltage than the one included with this device. All warranty of this product will be voided in the situations above.

- **Don't open the housing of the product**

- **Cleaning**

Disconnect this video product from the power supply before cleaning.

- **Attachments**

Do not use attachments not recommended by the video product manufacturer as they may cause hazards.

- **Water and Moisture**

Do not use this video product near water, for example, near a bathtub, washbowl, kitchen sink, or laundry tub, in a wet basement, or near a swimming pool and the like.

- **Don't use accessories not recommended by the manufacturer**

- **Only install this device and the power supply in a dry place protected from weather**

- **Servicing**

Do not attempt to service this video product yourself as opening or removing covers may expose you to dangerous voltage or other hazards. Refer all servicing to qualified service personnel.

- **Damage Requiring service**

Disconnect this video product from the power supply immediately and refer servicing to qualified service personnel under the following conditions.

1. When the power-supply cord or plug is damaged.
2. If liquid has been spilled, or objects have fallen into the video product.
3. If the video product has been exposed to rain or water directly.



4. If the video product does not operate normally by following the operating Instructions in this manual. Adjust only those controls that are covered by the instruction manual as an improper adjustment . Other controls may result in damage and will often require extensive work by a qualified technician to restore the video product to its normal operation.

- **Safety Check**

Upon completion of any service or repairs to this video product, ask the service technician to perform safety checks to determine that the video product is in proper operating condition.

## 1.4 Physical Description

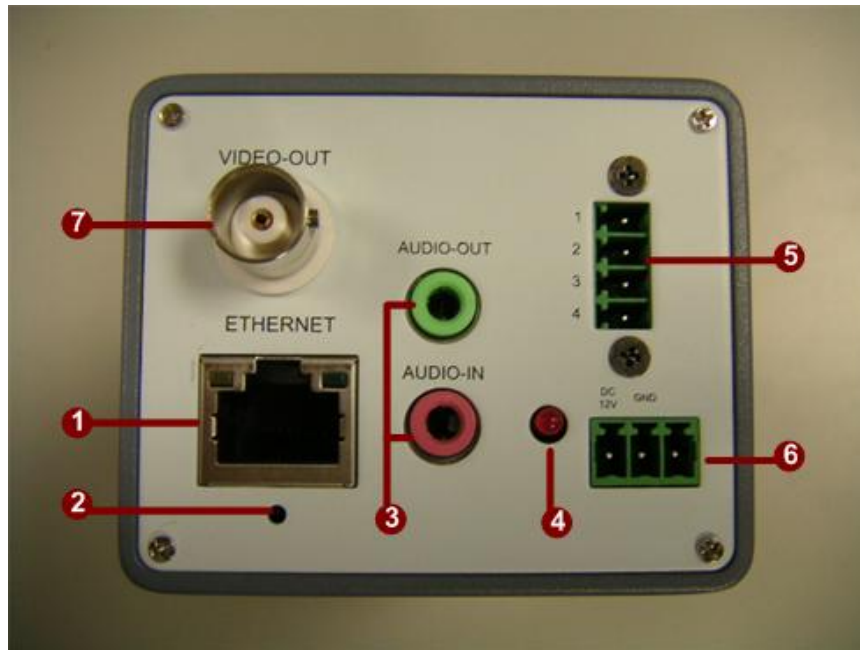

### 1. Ethernet Port

The IP device connects to the Ethernet via a standard RJ45 connector. Supporting NWAY, this IP device can auto detect the speed of local network segment (10Base-T/100Base-TX Ethernet).

### 2. Reset Button

**Step 1:** Switch off IP device by disconnecting the power cable

**Step 2:** Press and continue to hold the Reset Button. Reconnect the power cable while continuing to hold the reset button.

**Step 3:** Keep holding the reset button depressed around 6 seconds, release the reset button. The unit will start up with factory default settings.

### 3. Audio Input / Output

The IP device supports audio input and output with earphone jack

### 4. Action LED Indicator

The LED will light up after IP camera has successfully completed the boot process

### 5. The I/O Terminal Connector

Used in applications for e.g. motion detection, event triggering, time lapse recording, alarm notifications, etc., the I/O terminal

connector provides the interface to:

- 1 transistor output - For connecting external devices such as relays and LED:s. Connected devices can be activated by Output buttons on the Live View page or by an Event Type. The output will show as active (in Event Configuration > Port Status) if the alarm device is activated.
- 1 digital input - An alarm input for connecting devices that can toggle between an open and closed circuit, for example: PIRs, door/window contacts, glass break detectors, etc. When a signal is received the state changes and the input becomes active (shown under Event Configuration > Port Status).

•Auxiliary power and GND

	Pin	Description	Description
GND	Pin 1	Ground	
Auxiliary DC Power input (not to power this camera)	Pin 2	Electrically connected in parallel with the connector for the power supply, this pin provides an auxiliary connector for mains power to the unit. This pin can also be used to power auxiliary equipment, with a maximum current of 100mA.	Voltage: 12V DC, Max: 1.2W
Digital Input	Pin 3	Connect to GND to activate, or leave floating (or unconnected) to deactivate.	Must not be exposed to voltages greater than 30V DC.
Transistor Output	Pin 4	Uses an open-collector NPN transistor with the emitter connected to the GND pin. If used with an external relay, a diode must be connected in parallel with the load, for protection against voltage transients.	Max load = <100mA Max voltage = 24V DC (to the transistor)

The I/O terminal pins are numbered left to right, as shown below.



Connect input/output devices to the camera as follows:

1. Attach the cables for the device securely to the supplied green connector block.

- Once the cables are connected, push the connector block into the terminal connector (also green) on the camera.

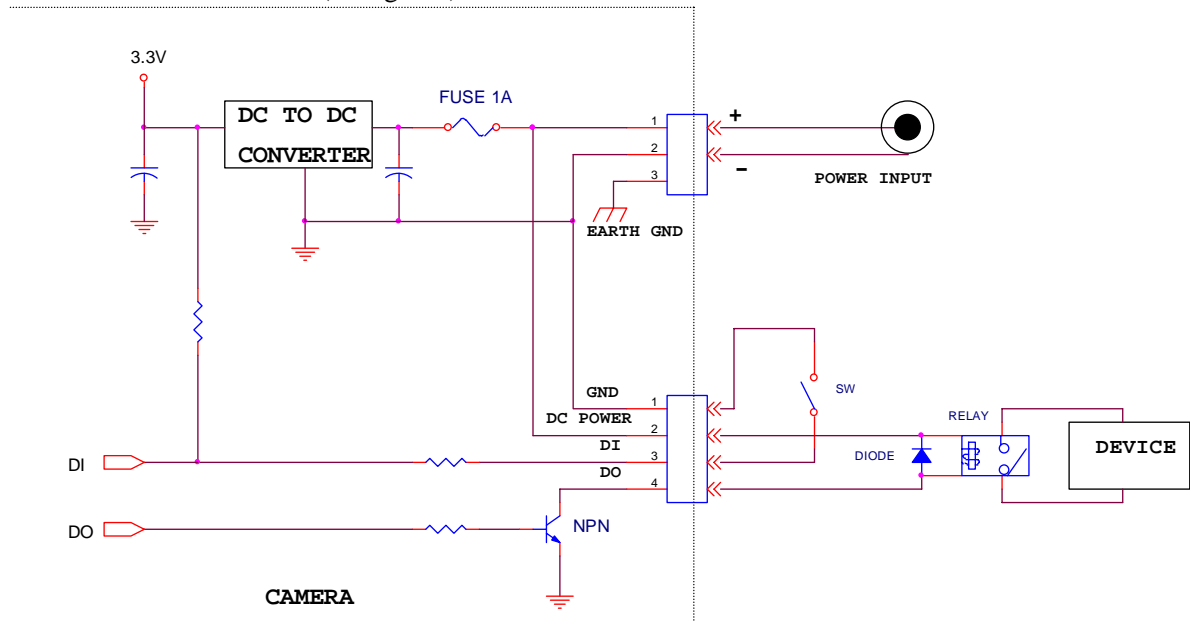

## 6. Power Input

If your power input is DC12V.

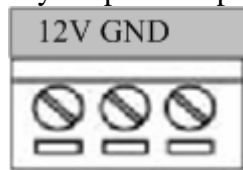

## 7. Analog Video Output

The IP Box Camera supports one channel analog video output.

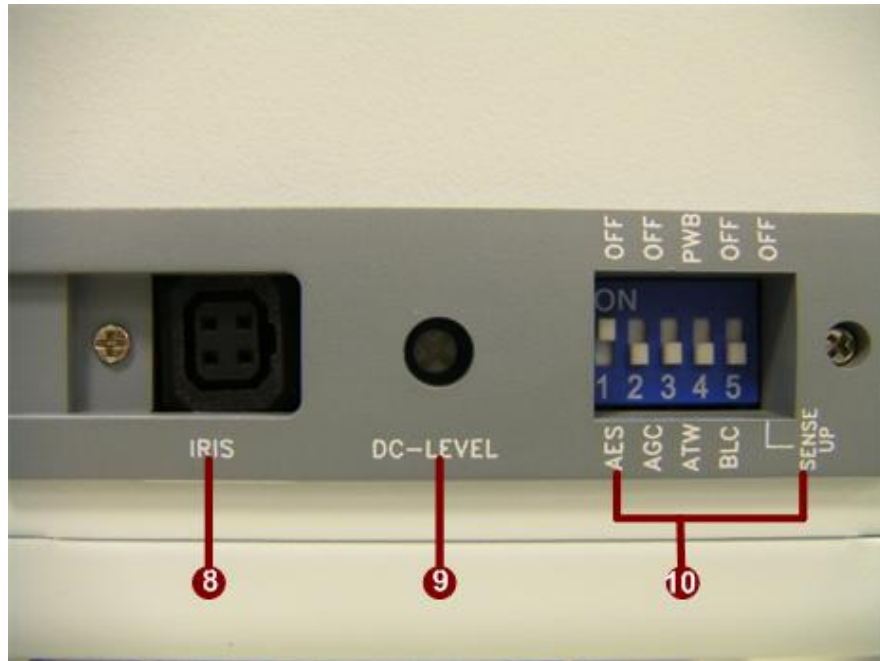

8. **Iris**

DC Iris

9. **Video DC Level Adjustment**

10. **CCD Functions**

● **Auto Electronic Shutter Speed Mode**

AES On: 1/50 (60) sec. ~ 1/120,000 sec;

AES Off: 1/50 (60) sec.

● **Automatic Gain Control**

ON/OFF (Switchable)

● **Auto White Balance**

ATW / Push Lock WB Mode

● **Back Light Compensation**

ON/OFF (Switchable)

● **Sense UP**

ON/OFF (Switchable)

## 1.5 Basic Connections

Follow the procedures below to connect the IP device to the respective apparatuses.

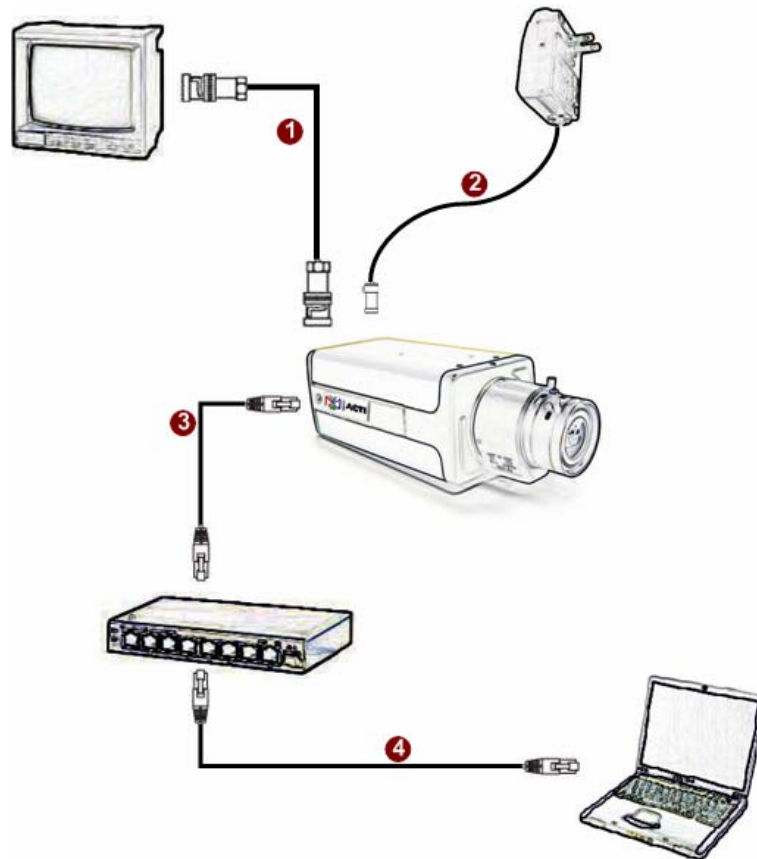

1. Connect the power adaptor to IP device
2. Connect IP device's ethernet port to an Ethernet (RJ45 connectors). If your IP device has PoE built-in, you can regard it as a PD and connect it directly to a PSE device like PoE switch.
3. Connect a PC to the Ethernet hub (RJ45 connectors)



**NOTE:** You may find a support package for help you getting familiar with PoE. Please visit our web site, and get the support document TS-00040.

## 1.6 Product Specification

		ACM-5711
<b>Image</b>	Device	1/3" SuperHAD CCD
	Size	1/3" inch
	Effective Pixels	537 x 505 (NTSC); 537 x 597 (PAL)
	Horizontal Resolution	420 TVL
<b>Min. scene Illumination</b>	Color	0.05 Lux at F1.0 (AES & Sense-UP ON)
	B/W	N/A
	CDS Sensor	N/A
	IR Sensitivity	N/A
<b>Lens</b>	Lens Mount	C /CS (with adaptor)
<b>Synchronization</b>	Sync. System	Internal
<b>Day/Night Functions</b>	Mechanical IR Cut Filter	N/A
	Motion Detection	Yes (3 Windows)
<b>Functions</b>	Electronic Shutter	1/60 ~ 1/120,000 sec. (NTSC) 1/50 ~ 1/120,000 sec. (PAL)
	BLC	Yes
	AGC	On /Off (switchable)
	White Balance	ATW /PWB (switchable)
	Auto Iris Control	DC Iris
<b>S/N Ratio</b>	S/N Ratio	Better than 44 dB
	Compression	MPEG-4 SP, MJPEG selectable
<b>Video Compression</b>	Picture Resolution	Full D1 (720x480 in NTSC, 720x576 in PAL) VGA (640x480 in NTSC, 640x480 in PAL) CIF (352x240 in NTSC, 352x288 in PAL) QCIF (160x112 in NTSC, 176x144 in PAL)
	Image Frame Rate	30 fps at Full D1 resolution (NTSC) 25 fps at Full D1 resolution (PAL)
<b>Audio Input</b>	Compression	8 kHz, Mono, PCM
	Audio Line Input	Unbalanced, 1.4Vp-p, 1Vrms, 3.5 mm Phone Jack
<b>Audio Output</b>	Compression	8 kHz, Mono, PCM
	Audio Line Output	Unbalanced, 1.4Vp-p, 1Vrms, 3.5 mm Phone Jack
<b>Alarm</b>	Digital Input	1, terminal block
	Transistor Output	1, terminal block
<b>External I/O</b>	Reset Button	Factory default
	LED	System status
<b>Network</b>	Ethernet	Ethernet(10/100Base-T), RJ-45 connector
	Protocol	TCP, UDP, IP, HTTP, DHCP, PPPoE, RTP, RTSP, FTP, SMTP, DNS, DDNS, NTP, ICMP, IGMP, ARP, 3GPP
<b>Software</b>	Web Browser	Microsoft Internet Explorer 6.0 or above
	SDK	ActiveX control, C SDK
	Security	Password protection: configured by the administrator
<b>Operating</b>	Temperature	0 °C ~ 50 °C (32 °F ~ 122 °F)
<b>Power</b>	Power Requirement	PoE (IEEE802.3af) with Class 3
	Power Consumption	3.3 W (DC 12 V) 4.3 W (PoE)
<b>Physical</b>	Dimensions (WxHxD)	67 mm x 55 mm x 129.5 mm (2.64" x 2.17" x 5.10")
	Weight	400 g (0.88 lb)