**User's
Manual**

YS1000™ Series

**YS110
Standby Manual Station**

IM 01B08G01-01E

vigilantplant.®

Product Registration

Thank you for purchasing YOKOGAWA products.

YOKOGAWA provides registered users with a variety of information and services.

Please allow us to serve you best by completing the product registration form accessible from our homepage.

<http://www.yokogawa.com/ns/reg/>

Foreword

Thank you for purchasing the YS110 Standby Manual Station (hereinafter referred to as "YS110").

This manual describes the basic functions and operation methods of the YS110. Please read through this user's manual carefully before using the product.

Notice

- The contents of this manual are subject to change without notice as a result of continuing improvements to the instrument's performance and functions.
- Every effort has been made to ensure accuracy in the preparation of this manual. Should any errors or omissions come to your attention, however, please inform YOKOGAWA Electric's sales office or sales representative.
- Under no circumstances may the contents of this manual, in part or in whole, be transcribed or copied without our permission.

Trademarks

- Our product names or brand names mentioned in this manual are the trademarks or registered trademarks of YOKOGAWA Electric Corporation (hereinafter referred to as YOKOGAWA).
- Microsoft, MS-DOS, Windows, Windows XP, and Windows NT are either registered trademarks or trademarks of Microsoft Corporation in the United States and/or other countries.
- Adobe, Acrobat, and Postscript are either registered trademarks or trademarks of Adobe Systems Incorporated.
- We do not use the TM or ® mark to indicate these trademarks or registered trademarks in this user's manual.
- All other product names mentioned in this user's manual are trademarks or registered trademarks of their respective companies.

Revisions

4th Edition: June 2014

Safety Precautions

To use the instrument properly and safely, observe the safety precautions described in this user's manual when operating it. Use of the instrument in a manner not prescribed herein may compromise protection features inherent in the device. We assume no liability for or warranty on a fault caused by users' failure to observe these instructions.

■ Notes on the User's Manual

- This user's manual should be readily accessible to the end users so it can be referred to easily. It should be kept in a safe place.
- Read the information contained in this manual thoroughly before operating the product.
- The purpose of this user's manual is not to warrant that the product is well suited to any particular purpose, but rather to describe the functional details of the product.

■ Safety, Protection, and Modification of the Product

The following symbols are used in the product and user's manuals to indicate safety precautions:



"Handle with Care" (This symbol is attached to the part(s) of the product to indicate that the user's manual should be referred to in order to protect the operator and the instrument from harm.)



Protective grounding terminal



Functional grounding terminal (Do not use this terminal as a protective grounding terminal.)



Alternating current



Direct current



ON (power)



OFF (power)

- In order to protect the system controlled by this product and the product itself, and to ensure safe operation, observe the safety precautions described in this user's manual. Use of the instrument in a manner not prescribed herein may compromise the product's functions and the protection features inherent in the device.

We assume no liability for safety, or responsibility for the product's quality, performance or functionality should users fail to observe these instructions when operating the product.

- Installation of protection and/or safety circuits with respect to a lightning protector; protective equipment for the system controlled by the product and the product itself; foolproof or failsafe design of a process or line using the system controlled by the product or the product itself; and/or the design and installation of other protective and safety circuits are to be appropriately implemented as the customer deems necessary.
- Be sure to use the spare parts approved by YOKOGAWA when replacing parts or consumables.
- This product is not designed or manufactured to be used in critical applications that directly affect or threaten human lives. Such applications include nuclear power equipment, devices using radioactivity, railway facilities, aviation equipment, air navigation facilities, aviation facilities, and medical equipment. If so used, it is the user's responsibility to include in the system additional equipment and devices that ensure personnel safety.
- Modification of the product is strictly prohibited.

WARNING

- **Power Supply**
Ensure that the instrument's supply voltage matches the voltage of the power supply before turning ON the power.
- **Protective Grounding**
To prevent electric shock, always confirm that protective grounding is connected before turning ON the instrument's power supply.
- **Necessity of Protective Grounding**
Do not cut off the internal or external protective grounding wire or disconnect the wiring of the protective grounding terminal. Doing so renders the protective functions of the instrument invalid and poses a potential shock hazard.
- **Defects in Protective Functions**
If protective functions such as grounding are suspected to be defective, do not operate the instrument. Ensure that all protective functions are in working order before operating the instrument.
- **Do Not Use in an Explosive Atmosphere**
Do not operate the instrument in locations with combustible or explosive gases or steam. Operation in such environments constitutes an extreme safety hazard. Use of the instrument in environments with high concentrations of corrosive gas (H₂S, SO_x, etc.) for extended periods of time may cause a failure.
- **Explosion hazard**
Do not connect the YS110 in explosive atmospheres.
- **External Connection**
Ensure that protective grounding is connected before connecting the instrument to the device under measurement or to an external control circuit.
- **Damage to the Protective Construction**
Operation of the instrument in a manner not specified in this user's manual may damage its protective construction.

■ **Warning and Disclaimer**

- YOKOGAWA makes no warranties regarding the product except those stated in the WARRANTY that is provided separately.
- The product is provided on an "as is" basis. YOKOGAWA assumes no liability to any person or entity for any loss or damage, direct or indirect, arising from the use of the product or from any unpredictable defect of the product.

Handling Precautions for the Main Unit

- The instrument comprises many plastic components. To clean it, wipe it with a soft, dry cloth. Do not use organic solvents such as benzene or thinner for cleaning, as discoloration or deformation may result.
- Keep electrically charged objects away from the signal terminals. Not doing so may cause the instrument to fail.
- Do not apply volatile chemicals to the display area, operation keys, etc. Do not leave the instrument in contact with rubber or PVC products for extended periods. Doing so may result in failure.
- Remove the internal batteries when you will not use the YS110 for an extended period of time. Liquid may leak out from the batteries.
- If the equipment emits smoke or abnormal smells or makes unusual noises, turn OFF the instrument's power switch immediately and unplug the device. In such an event, contact your sales representative.

How to Replace and Dispose the Batteries

This is an explanation about the new EU Battery Directive (DIRECTIVE 2006/66/EC). This directive is only valid in the EU. Batteries are included in this product. When you remove batteries from this product and dispose them, discard them in accordance with domestic law concerning disposal. Take a right action on waste batteries, because the collection system in the EU on waste batteries are regulated.

Battery type: Manganese dry battery

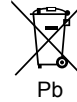

Notice: The symbol (see above), which is marked on the batteries, means they shall be sorted out and collected as ordained in ANNEX II in DIRECTIVE 2006/66/EC. The chemical symbol beneath the symbol (crossed out wheeled dust bin symbol) means relevant chemical substance is contained more than criterion value in battery.

Criterion value (weight percent):
mercury(Hg):0.0005%, cadmium(Cd):0.002%, lead(Pb):0.004%
How to remove batteries safely: Please see section 3.1, "Battery Replacement."

Checking the Contents of the Package

Unpack the box and check the contents before using the product. If the product is different from that which you have ordered, if any parts or accessories are missing, or if the product appears to be damaged, contact your sales representative.

YS110 Main Unit

Check the model and suffix codes inscribed on the nameplate to confirm that the product received is that which was ordered.

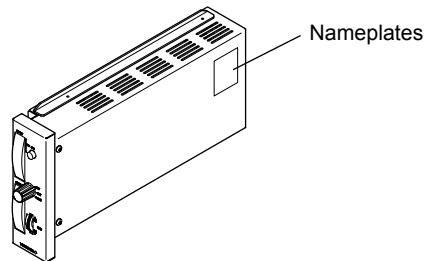

0001E.ai

No. (Instrument number)

When contacting your sales representative, inform them of this number too.

Model and Suffix Codes

Model	Suffix Code	Optional Code	Remarks
YS110			Standby Manual Station
Use	-0		General purpose
	0		Always "0"
Power supply		1	100 V version
		2	220 V version
Optional specification		/CSA	CSA non-incendive approved

Accessories

The product is provided with the following accessories. Check that none of them are missing or damaged.

- Connection Cable (Length:2 m): 1pc
- Tag Number Labels: 4 sheets
- User's Manual (this manual): IM 01B08G01-01E

Symbols Used in This Manual



This symbol is used on the instrument. It indicates the possibility of injury to the user or damage to the instrument, and signifies that the user must refer to the user's manual for special instructions. The same symbol is used in the user's manual on pages that the user needs to refer to, together with the term "WARNING" or "CAUTION."

WARNING

Calls attention to actions or conditions that could cause serious or fatal injury to the user, and indicates precautions that should be taken to prevent such occurrences.

CAUTION

Calls attention to actions or conditions that could cause injury to the user or damage to the instrument or property and indicates precautions that should be taken to prevent such occurrences.

Note

Identifies important information required to operate the instrument.



Indicates related operations or explanations for the user's reference.

Contents

1

2

3

4

Foreword	i
Safety Precautions	i
Handling Precautions for the Main Unit	ii
How to Replace and Dispose the Batteries	ii
Checking the Contents of the Package	ii
Symbols Used in This Manual	iii

Chapter 1 Before Starting Operation

1.1 General.....	1-1
1.2 Names and Functions of Parts	1-3
1.3 Battery Voltage Level Check	1-4

Chapter 2 Operation

2.1 Output Switching from YS Instrument with MV Output to YS110	2-1
2.2 Output Switching from YS110 to YS Instrument with MV Output	2-3
2.3 Installation and Removal from the Case Compatible with YS100	2-4

Chapter 3 Maintenance

Battery Replacement	3-1
Fuse Specification.....	3-2
Notes for Sending Products to be Repaired	3-2

Chapter 4 Specifications

General Specification.....	4-1
Input Signal and MV Signals.....	4-1
Power Supply.....	4-1
Standard Performance.....	4-2
Installation and Shape	4-2
Hazardous Location Usage Certification.....	4-2
Normal Operating Conditions.....	4-2
External Dimensions	4-3

1.1 General

The YS110 is a standby manual station. If a YS1500, YS1700, YS150, YS170, YS1360 or YS136 instrument fails, the YS110 Standby Manual Station can be used to output a 4 to 20 mA DC signal to the control valve actuator instead of the instrument. The internal unit of each instrument can be exchanged while the output is back up by the YS110. The YS110 can also be used to monitor the input signal.

In this manual, YS1500, YS1700, YS150, YS170, YS1360, and YS136 are called “YS instrument with MV output.”



WARNING

Explosion hazard.

For the YS1500, YS1700, and YS1360 with optional code /FM, do not remove or insert the internal unit or do not connect the YS110 in explosive atmospheres.



CAUTION

- For the YS1500, YS1700, and YS1360, do not remove the internal unit from the instrument case. Contact Yokogawa's sales office or sales representative when removing the internal unit of the YS1500, YS1700, and YS1360, as safety standard inspection is required.
- The YS110 can be installed only in the case of the YS1500, YS1700, or YS1360 of compatible type for YS100.

Principles of Operation

Process variable (input) signal of the YS instrument with MV output is input to the YS110 via a cable by plugging its cable into a connector on the case of the YS instrument with MV output. Then, it is applied to a high input resistance (R_{IN}), input filter (R and C), buffer amplifier (U_1) and switch. The level of the signal can be indicated on the input indicator. The voltage level of the internal batteries can also be indicated on this input indicator by pressing the battery check push button.

For the manipulated variable, the value set by the manual operation wheel is applied to Q_1 via the buffer amplifier (U_2), and converted from a voltage value to a current value. Then, it is output from the output terminals on the case, via the manipulated variable indicator and the switch, to the control valve actuator.

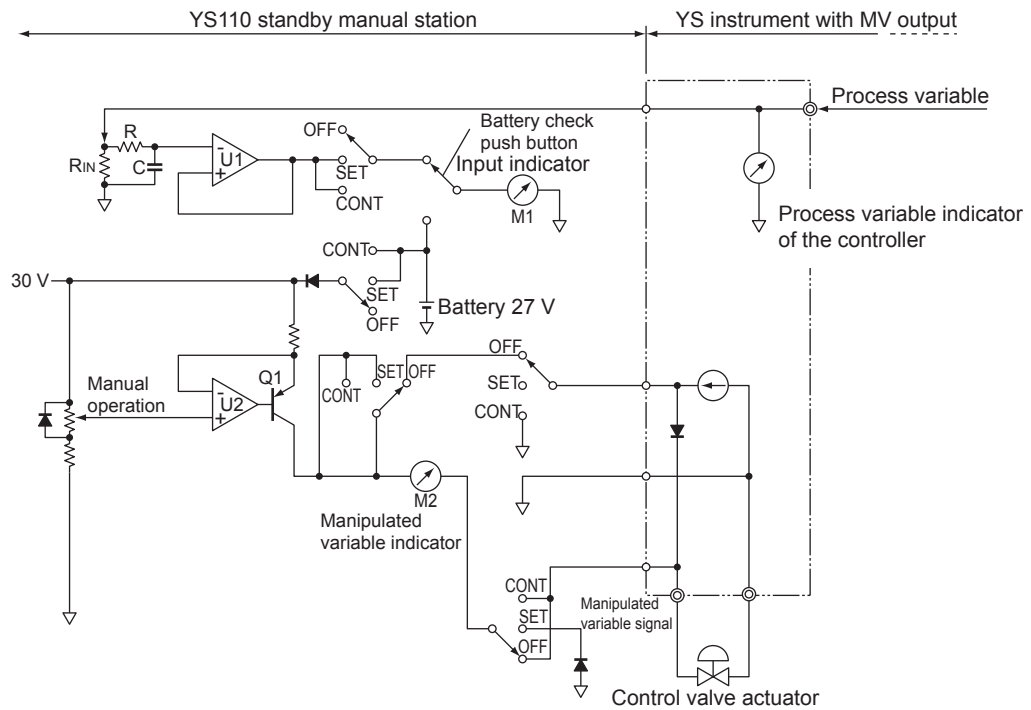

1.2 Names and Functions of Parts

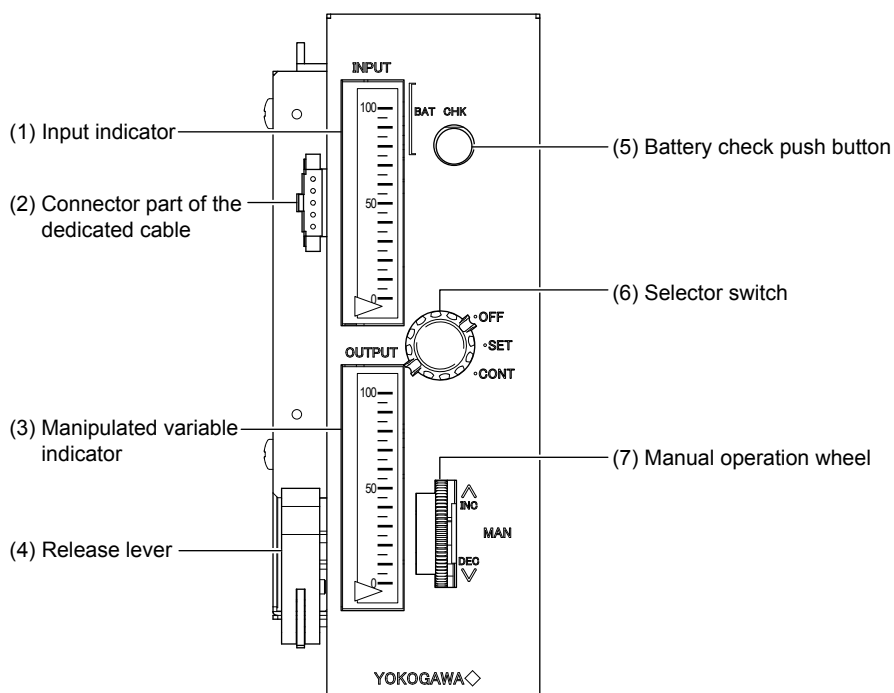

Names and Function of Parts

(1) Input indicator

Indicates the process variable (input) signal in the range 0 to 100% when the selector switch is set to SET or CONT.

(2) Connector part of the dedicated cable

Connects the YS instrument with MV output to the YS110 using the dedicated cable.

(3) Manipulated variable indicator

Shows the manipulated variable of the YS instrument with MV output when the selector switch is set to OFF. It shows the manipulated variable of the YS110 when the selector switch is set to SET or CONT.

(4) Release lever

Removes the YS110 from the case of the YS instrument with MV output.

(5) Battery check push button

The battery voltage level is displayed on the input indicator when the push button is pressed.

(6) Selector switch

Selects the desired setting of the manipulated variable and output. It has positions OFF, SET, and CONT.

(7) Manual operation wheel

Controls a manipulated variable manually.

1.3 Battery Voltage Level Check

CAUTION

If you use the YS110 with insufficient battery level, the backup operation may be interrupted.

You must carry out battery voltage level check before use and exchange the battery as necessary.

Procedure

1. Set the selector switch to SET.
2. Operate the manual operation wheel to set 100% on manipulated variable indicator.
3. Press the battery check push button.

While the battery check push button is held down, the input indicator shows the battery voltage level.

When the level is 100 to 75%: The YS110 can be used.

(The YS110 will operate continuously for 10 minutes when the level indication is 75%.)

When the level is less than 75%: Replace the batteries before starting operation.

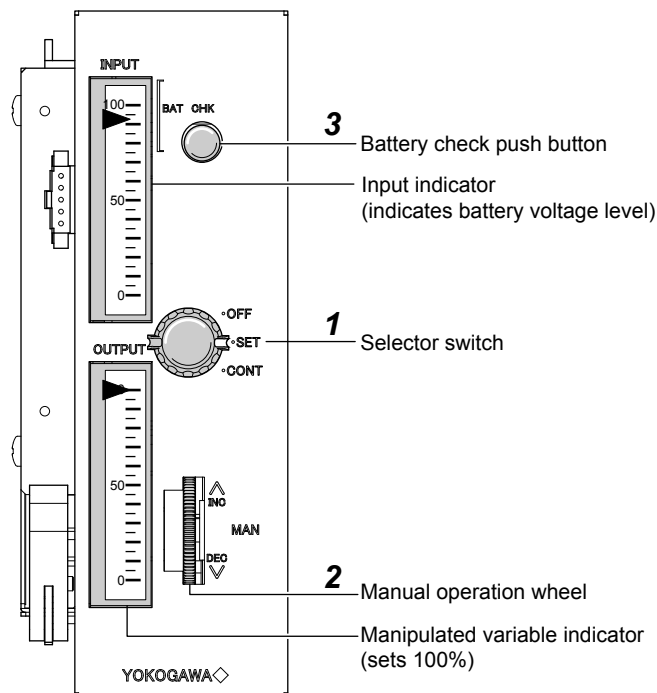

► See section 3.1, "Battery Replacement."

NOTE

- When the YS110 is installed in the case compatible with YS100, a power supply is supplied from the case and the power supply from a battery is interrupted.
- Since it is necessary to give the maximum load in order to check battery voltage level, set 100% on manipulated variable indicator.

2.1 Output Switching from YS Instrument with MV Output to YS110

CAUTION

- If you connect the YS110 with its selector switch CONT, it is especially dangerous because manipulated variable of the YS110 will suddenly be output to the control valve actuator.
Be sure to confirm that the selector switch is OFF before carrying out the operations in this section.
- For the YS1500, YS1700, and YS1360, touch the metal lever to discharge static electricity before you connect the exclusive cable to the YS110 connector.

Procedure

1. Check that the selector switch on the YS110 is set to OFF.
2. Connect one end of the dedicated cable to the connector of the YS110.
3. Swing up the front panel of the YS instrument with MV output.
4. Push up the metal lever to discharge static electricity. (for YS1500, YS1700, and YS1360 only)
5. Connect the other end of the dedicated cable to the connector for the YS110 Standby Manual Station located behind the swung-up part of the YS instrument with MV output.
 - The manipulated variable indicator shows the manipulated variable of the YS instrument with MV output.
6. Set the selector switch of the YS110 to SET.
 - The input indicator shows the process variable of the YS instrument with MV output.
 - The manipulated variable indicator shows the manipulated variable of the YS110. (The manipulated variable of the YS110 is not output to the control valve actuator.)
7. Balance the manipulated variable using the manual operation wheel of the YS110.
 - Adjust to the manipulated variable (the value read at step 5 above) of the YS instrument with MV output or to a desired manipulated variable.
8. Set the selector switch of the YS110 to CONT.
 - The control valve actuator can be controlled with the manual operation wheel of the YS110.
 - The input indicator shows the process variable and the manipulated variable indicator shows the manipulated variable of the YS110.

YS instrument with MV output

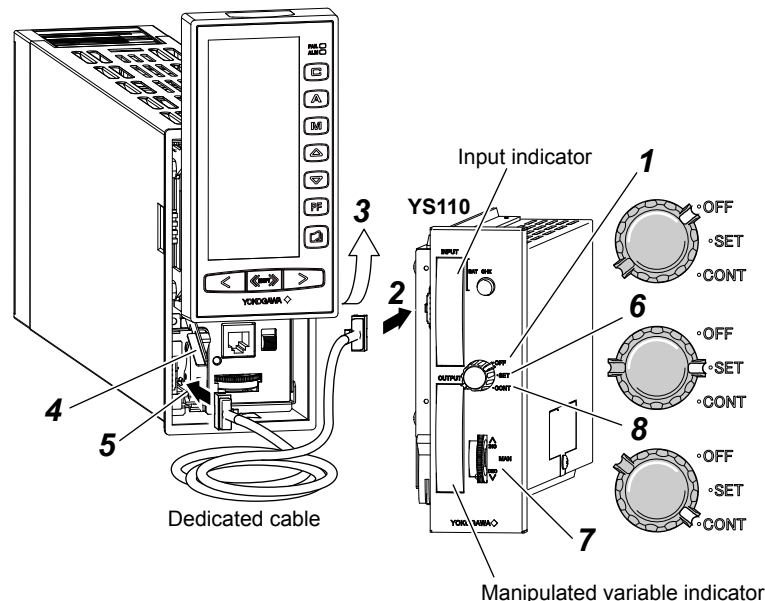

9. Remove the internal unit of the YS instrument with MV output from the case.
 - ▶ See the user's manual of each instrument for how to remove the internal unit from the case.
10. Install the YS110 into the case of the YS instrument with MV output if necessary.
 - ▶ See section 2.3, "Installation and Removal from the Case Compatible with YS100" for how to install the YS110 in the case.



WARNING

Explosion hazard.
 For the YS1500, YS1700, and YS1360 with optional code /FM, do not remove or insert the internal unit or do not connect the YS110 in explosive atmospheres.

CAUTION

- Leave the dedicated cable connected even after installing the YS110 in the case of the YS instrument with MV output. If you disconnect the cable, backup operation will be disabled because the YS110 receives and outputs signals via this cable.
- For the YS1500, YS1700, and YS1360, do not remove the internal unit from the instrument case. Contact Yokogawa's sales office or sales representative when removing the internal unit of the YS1500, YS1700, and YS1360, as safety standard inspection is required.
- The YS110 can be installed only in the case of the YS1500, YS1700, and YS1360 of compatible type for YS100.
- The YS1500, YS1700, and YS1360 with optional code /FM or /CSA cannot satisfy the explosion protection standards if the internal unit is removed.

Relationship between the Position of the Selector Switch and the Functions

Switch Setting	Control Valve Actuator Operation by YS110	Manipulated Variable Indication	Input Indication
OFF	Impossible	Manipulated variable of the YS instrument with MV output	No indication
SET	Impossible	Desired manipulated variable of the YS110	Process variable
CONT	Possible	Manipulated variable of the YS110	Process variable

CAUTION

Do not connect or disconnect the cable when the selector switch is set to SET or CONT.
 If you disconnect the cable, the operation will be disabled because the YS110 receives and outputs signals via this cable.
 Also, it may cause a sudden change to the control valve actuator when connecting or disconnecting the cable.

2.2 Output Switching from YS110 to YS Instrument with MV Output

This procedure is to be applied when the YS instrument with MV output is recovered and manual operation from the YS110 is no longer necessary.

Procedure

- When the YS110 is installed in the case of the YS instrument with MV output, remove the YS110 from the case while leaving the cable connected.
 - ▶ See section 2.3, "Installation and Removal from the Case Compatible with YS100" for how to remove the YS110 from the case.

- Install the YS instrument with MV output in the case.
 - In this case, the selector switch of the YS110 shall be set to CONT.

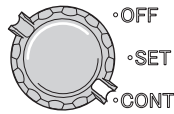

- Set the YS instrument with MV output in manual operation mode.
- Adjust the manipulated variable of the YS instrument with MV output to that of the YS110.
- Set the selector switch of the YS110 to SET.
 - Then the control valve actuator is controlled by the manipulated variable of the YS instrument with MV output.

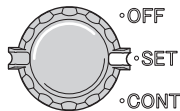

- Check that the manipulated variable is switched to the YS instrument with MV output, and then set the selector switch of the YS110 to OFF.

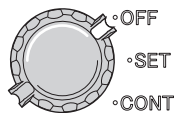

- Detach the connector of the cable from the connector of the case on the YS instrument with MV output.

CAUTION

Set the selector switch to OFF when you store the YS110 to avoid wasting the battery.

Remove the batteries when you will not use the YS110 for an extended period of time. Liquid may leak out from the batteries.

2.3 Installation and Removal from the Case Compatible with YS100



WARNING

Explosion hazard.

For the YS1500, YS1700, and YS1360 with optional code /FM, do not remove or insert the internal unit or do not connect the YS110 in explosive atmospheres.

CAUTION

- For the YS1500, YS1700, and YS1360, do not remove the internal unit from the instrument case. Contact Yokogawa's sales office or sales representative when removing the internal unit of the YS1500, YS1700, and YS1360, as safety standard inspection is required.
- The YS110 can be installed only in the case of the YS1500, YS1700 or YS1360 of compatible type for YS100.

Installing in the Case Compatible with YS100

1. Place the guides on the top and bottom of the YS110 on the guide rails of the case.
2. Push in the YS110 until it reaches the connector with a click sound.

Removing from the Case Compatible with YS100

1. Pull the release lever on the side of the YS110 to the front.
 - The connector at the rear comes off.
2. Pull the YS110 to the front while holding the left and right sides of the YS110.

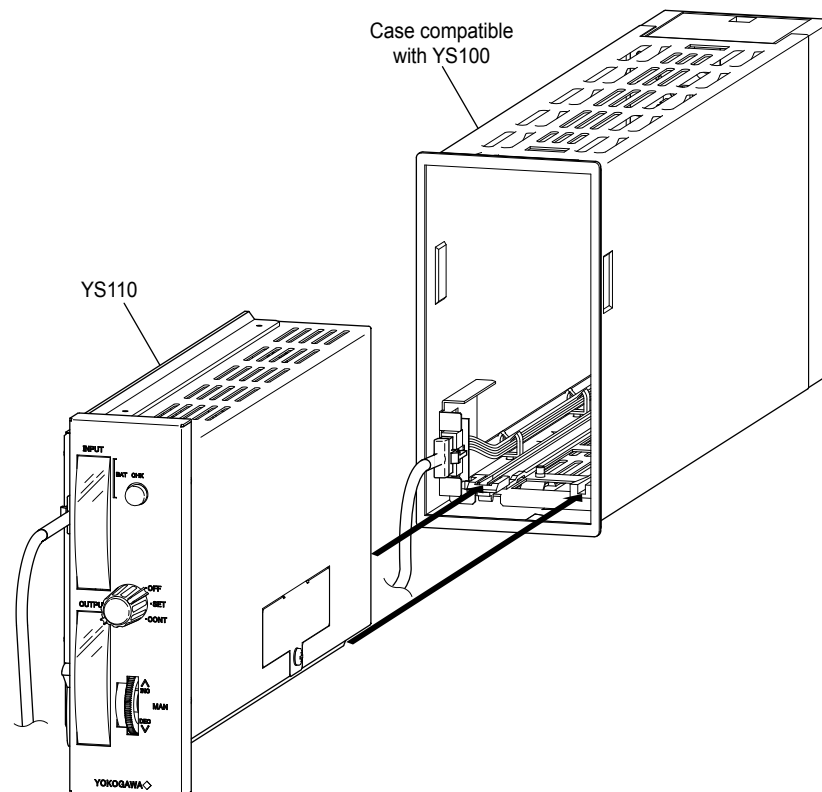

CAUTION

If there is dirt or dust on the YS110, wipe it with a soft dry cloth.
Note that if you use any organic solvents, chemicals or chemical cloth, the case of the YS110 may be changed in its shape or color.

Battery Replacement

Check the battery voltage level. When it is less than 75% of the full level, replace the internal batteries.

► See section 1.3, “Battery Voltage Level Check.”

Tools and Batteries Required for Replacement

- New batteries (6F22), three required (Part No. A1005EB)
- Phillips screwdriver

1. Check that the selector switch of the YS110 is set to OFF.
2. Detach the fixing screw for the battery case lid on the side of the YS110 with a Phillips screwdriver.
3. Detach the battery case lid and remove the batteries.
 - Battery snap buttons for battery electrode connection are connected to each battery.
 - Take the batteries out of the YS110 while they are connected with the snap-on connectors.
4. Unfasten the snap-on connectors from the batteries
5. Fasten the snap buttons with the new batteries.
 - Do not fasten the snap-on connectors with the polarities + and – of the batteries reversed.
6. Check that the each battery is correctly connected with the snap-on connectors.
7. Install the new batteries being connected with the snap buttons in the YS110.
8. Attach the battery case lid to the YS110.

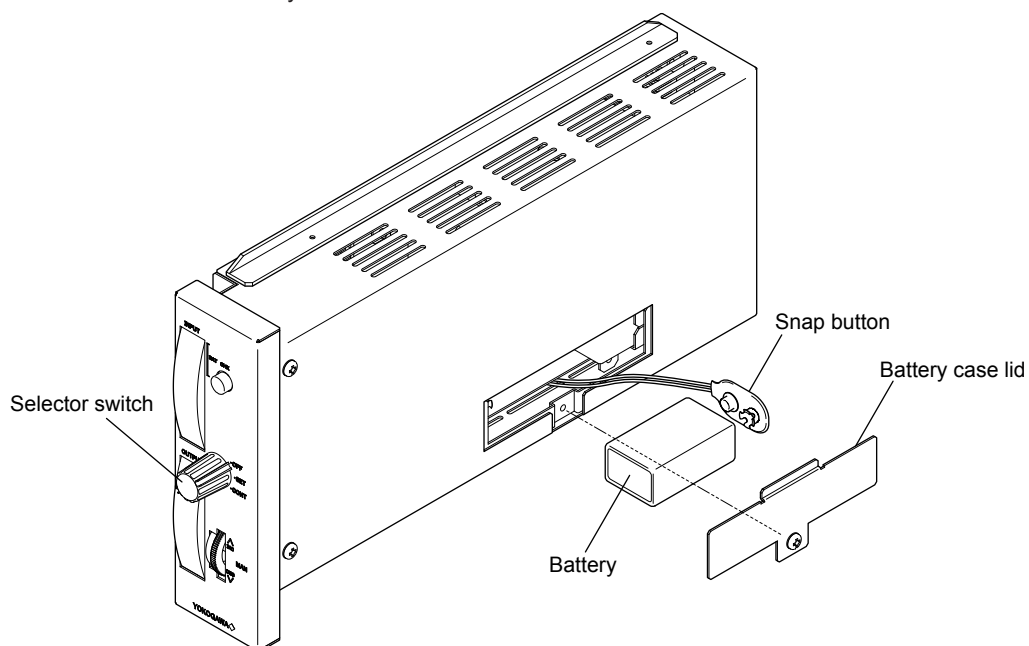

CAUTION

When you attach the battery case lid, be careful not to insert a battery connecting cable with the battery case lid.

Fuse Specification

The fuses employed in YS110 are free from periodically replacement because it is not a short-life part.

CAUTION

To carry out fuse replacement, sufficient handling skill of the instrument and also soldering skill are required. Contact Yokogawa's sales office or sales representative when removing the internal unit of the YS1500, YS1700, and YS1360, as safety standard inspection is required.

Part No.	Rated Current	Rated Voltage	Fuse Characteristics	Remarks
A1422EF	1.6 A	250 V	Quick acting (F)	For both 100 V and 220 V version

Notes for Sending Products to be Repaired

If you have trouble with the YS110, please send it to our sales representative for repair in accordance with the following.

WARNING

Put the YS110 into an antistatic bag and put into the packing box with the inner package.
Be sure to use an antistatic bag to protect semiconductor integrated circuits from damages caused by static electricity.

General Specification

Input Signal and MV Signals

Input signal:	1 to 5 V DC, 1 point
Input resistance:	1 M Ω
MV output signal:	4 to 20 mA DC, 1 point
Load resistance:	0 to 750 Ω
Input indicator and manipulated variable indicator:	Indicator; Moving coil type
	Range; 0 to 100%
	Scale; 20 equal divisions
MV operation:	Manual operation by operation wheel (on the front panel)
I/O connection:	Connected to the connector on the YS instrument with MV output by supplied cable.
Instrument for backed up:	YS1500, YS1700, YS150, YS170, YS1360, YS136

Power Supply

Internal Batteries

Battery:	6F22 dry cell (9 V), three required (Part No. A1005EB)
Continuous operating duration:	1 hour (with new batteries Max.)
Battery voltage level check:	Provided
	Set the selector switch to SET. Operate the manual operation wheel to set 100% on manipulated variable indicator. Push the battery check push button to display the remaining life of the internal battery. If the indicator indicates more than 75% of span, you can continue using this battery.
	(Remaining operating duration when the level indication is 75 %; 10 minutes)
	► See section 1.3, "Battery Voltage Level Check."

External Power Supply

When installed in the case of the YS instrument with MV output, power is supplied via the connector in the back of the instrument, and the internal battery is disconnected.

Rated power supply voltage:	For both DC and AC
100 V version	DC drive; 24-120 V DC \equiv ($\pm 10\%$), no polarity AC drive; 100-120 V AC \sim ($\pm 10\%$), 50/60 Hz (± 3 Hz)
220 V version	DC drive; 135-190 V DC \equiv ($\pm 10\%$), no polarity AC drive; 220-240 V AC \sim ($\pm 10\%$), 50/60 Hz (± 3 Hz)

On the other hand, the instruments themselves have the ability to operate under the conditions as shown below which is the same as the former description of the power supply voltage.

Usable power supply voltage:	For both DC and AC
100 V version	DC drive; 20-130 V DC, no polarity AC drive; 80-138 V AC, 47-63 Hz
220 V version	DC drive; 120-340 V DC, no polarity AC drive; 138-264 V AC, 47-63 Hz

Standard Performance

Accuracy rating of input indicator and manipulated variable indicator:
±2.5% of span

Maximum Current Flow and Power Consumption:

Power Supply	Range	Maximum Value	Typical Value
100 V version	20-130 V DC	190 mA	130 mA
	80-138 V AC	14 VA	8.4 VA
220 V version	120-340 V DC	130 mA	13 mA
	138-264 V AC	14 VA	10 VA

Insulation resistance: Between I/O terminals and ground; 100 MΩ/500 V DC
Between power terminal and ground; 100 MΩ/500 V DC
Withstanding voltage: Between I/O terminals and ground; 500 V AC for 1 minute
Between power terminal and ground;
100 V AC version: 1000 V AC for 1 minute
220 V AC version: 1500 V AC for 1 minute

Installation and Shape

Mounting method: Portable case (can also be installed in the case compatible with YS100 of the YS instrument with MV output); supplied with a 2 m long connection cable
Panel mounting: Can be installed in the case compatible with YS100 of the YS instrument with MV output
Dimensions (H × W × D):
144 × 58 × 295 (mm)
Weight: 1.6 kg

Hazardous Location Usage Certification



WARNING

The YS110 is not an FM non-incendive compliant instrument.
Explosion hazard.
Do not connect the YS110 in explosive atmospheres.

The YS110 with optional code /CSA is CSA approved as shown below.
CSA standard: CSA C22.2 No.213
(Non-incendive electrical equipment for use in hazardous locations)
Location: Class I, Division 2, Groups A, B, C & D
Temperature code: T4

Normal Operating Conditions

Ambient temperature: 0 to 50°C
Ambient humidity: 5 to 90% RH (no condensation)
Installation location: Room
Installation height: Altitude up to 2000m

External Dimensions

Unit: mm

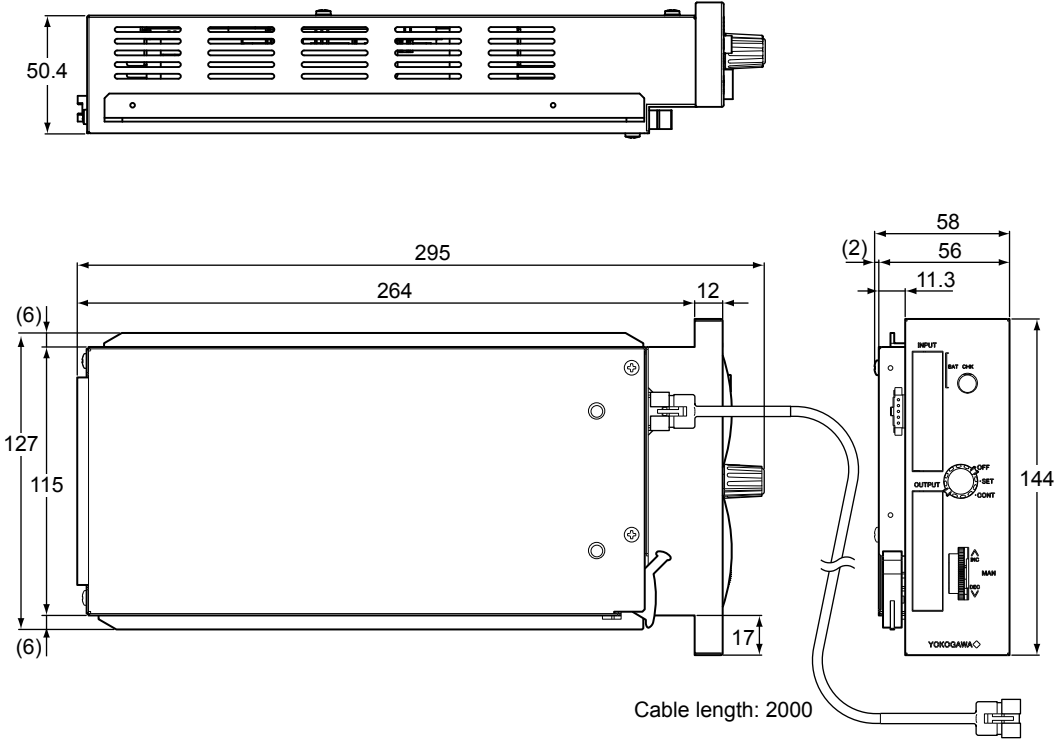

Weight: 1.6 kg

Revision Information

- Title : YS110 Standby Manual Station
- Manual No. : IM 01B08G01-01E

Mar. 2007/1st Edition

Newly published

Sep. 2007/2nd Edition

New EMC, Error correction

Sep. 2009/3rd Edition

Change of EMC number

June 2014/4th Edition

Error corrections

-
- Written by Yokogawa Electric Corporation
 - Published by Yokogawa Electric Corporation
2-9-32 Nakacho, Musashino-shi, Tokyo 180-8750, JAPAN
-

Blank Page



YOKOGAWA ELECTRIC CORPORATION

Headquarters

2-9-32, Nakacho, Musashino-shi, Tokyo, 180-8750 JAPAN
Phone : 81-422-52-5555

Branch Sales Offices

Osaka, Nagoya, Hiroshima, Kurashiki, Fukuoka, Kitakyusyu

YOKOGAWA CORPORATION OF AMERICA

Head Office

12530 West Airport Blvd, Sugar Land, Texas 77478, USA
Phone : 1-281-340-3800 Fax : 1-281-340-3838

Georgia Office

2 Dart Road, Newnan, Georgia 30265, USA
Phone : 1-800-888-6400/ 1-770-253-7000 Fax : 1-770-254-0928

YOKOGAWA AMERICA DO SUL LTDA.

Praca Acapulco, 31 - Santo Amaro, São Paulo/SP, BRAZIL, CEP-04675-190
Phone : 55-11-5681-2400 Fax : 55-11-5681-4434

YOKOGAWA EUROPE B. V.

Euroweg 2, 3825 HD Amersfoort, THE NETHERLANDS
Phone : 31-88-4641000 Fax : 31-88-4641111

YOKOGAWA ELECTRIC CIS LTD.

Grokholskiy per 13 Building 2, 4th Floor 129090, Moscow, RUSSIA
Phone : 7-495-737-7868 Fax : 7-495-737-7869

YOKOGAWA CHINA CO., LTD.

3F Tower D Cartelo Crocodile Building, No.568 West Tianshan Road,
Shanghai 200335, CHINA
Phone : 86-21-62396262 Fax : 86-21-62387866

YOKOGAWA ELECTRIC KOREA CO., LTD.

(Yokogawa B/D, Yangpyeong-dong 4-Ga), 21, Seonyu-ro 45-gil, Yeongdeungpo-gu,
Seoul, 150-866, KOREA
Phone : 82-2-2628-6000 Fax : 82-2-2628-6400

YOKOGAWA ENGINEERING ASIA PTE. LTD.

5 Bedok South Road, Singapore 469270, SINGAPORE
Phone : 65-6241-9933 Fax : 65-6241-2606

YOKOGAWA INDIA LTD.

Plot No.96, Electronic City Complex, Hosur Road, Bangalore - 560 100, INDIA
Phone : 91-80-4158-6000 Fax : 91-80-2852-1442

YOKOGAWA AUSTRALIA PTY. LTD.

Tower A, 112-118 Talavera Road, Macquarie Park NSW 2113, AUSTRALIA
Phone : 61-2-8870-1100 Fax : 61-2-8870-1111

YOKOGAWA MIDDLE EAST & AFRICA B.S.C.(C)

P.O. Box 10070, Manama, Building 577, Road 2516, Busaiten 225, Muharraq,
BAHRAIN
Phone : 973-17-358100 Fax : 973-17-336100