

ENVISION™

Geothermal/Water Source Outdoor Split Heat Pumps

- R-410A Refrigerant
- 2, 3, 4, 5, 6 Ton Dual Capacity

Installation Information

Water Piping Connections

Desuperheater Connections

Electrical

Startup Procedures

Troubleshooting

Preventive Maintenance



Envision Series Outdoor Split Installation Manual



IM1615 07/08

WaterFurnace

Table of Contents

Nomenclature	2
Physical Characteristics	2
General Installation Information	3-6
Electrical Data	7
Water Piping	8
Air Handler Nomenclature & Coil Data	9
Line Set Sizing	9
Physical Data	10
Envision Coil Nomenclature	11
Refrigerant Coil Compatability	11
Heat Recovery Unit	12-14
Wiring Schematics	15
Microprocessor Controls	16-17
Operation Logic	18
DIP Switch Settings	19
Refrigeration	20-22
Pressure/Temperature Conversion Chart	23
Unit Operating Parameters	24
Pressure Drop and Recommended Flow Rates	28
Unit Startup & Troubleshooting	26-29
Preventive Maintenance	30
Replacement Procedures	30
Physical Dimensions	31

ENVISION™



Model Nomenclature

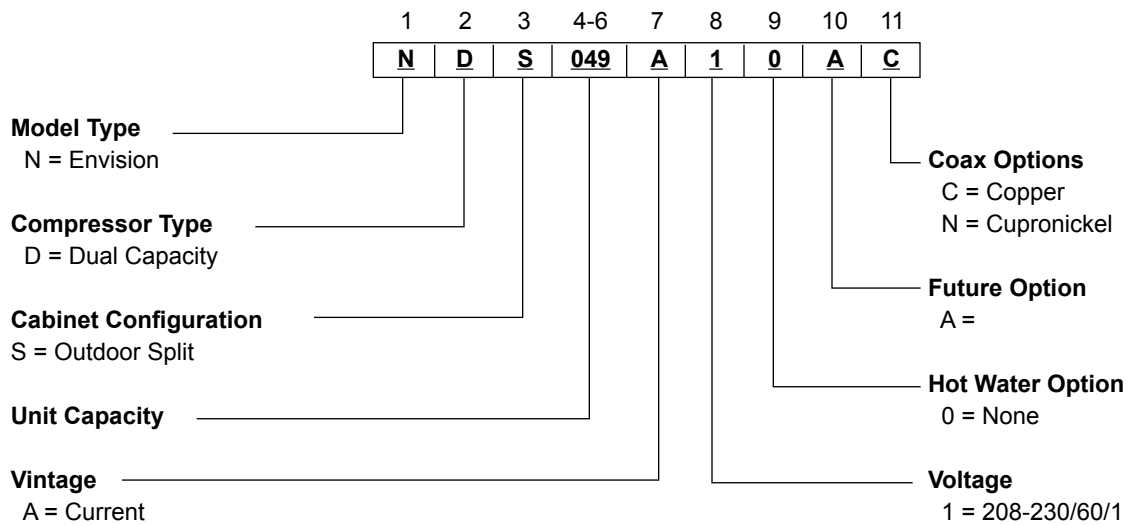

Physical Characteristics

Model	026	038	049	064	72
Compressor (1 each)	Dual Capacity Scroll				
Factory Charge R410a, oz [kg]	52 [1.47]	56 [1.59]	90 [2.55]	92 [2.61]	104 [2.95]
Coax and Water Piping					
Water Connections Size - Swivel- in [mm]	1 [25.4]				
HWG Connection Size - Swivel- in [mm]	1 [25.4]				
Coax & Piping Water Volume - gal [l]	0.7 [2.6]	1.3 [4.9]	1.6 [6.1]	1.6 [6.1]	2.3 [8.7]
Weight - Operating, lb [kg]	189 [186]	236 [107]	250 [113]	271 [123]	290 [132]
Weight - Packaged, lb [kg]	209 [95]	256 [116]	270 [122]	291 [132]	310 [141]

Notes: 4/9/08
All units have TXV expansion devices, and 1/2" [12.2mm] & 3/4" [19.1mm] electrical knockouts.

General Installation Information

Safety Considerations



WARNING: Before performing service or maintenance operations on a system, turn off main power switches to both units. Turn off accessory heater power switch if applicable. Electrical shock could cause personal injury. Installing and servicing heating and air conditioning equipment can be hazardous due to system pressure and electrical components. Only trained and qualified service personnel should install, repair or service heating and air conditioning equipment.

Installing and servicing heating and air conditioning equipment can be hazardous due to system pressure and electrical components. Only trained and qualified service personnel should install, repair or service heating and air conditioning equipment. Untrained personnel can perform the basic maintenance functions of cleaning coils and cleaning and replacing filters. All other operations should be performed by trained service personnel. When working on heating and air conditioning equipment, observe precautions in the literature, tags and labels attached to the unit and other safety precautions that may apply, such as the following safety measures:

- Follow all safety codes.
- Wear safety glasses and work gloves.
- Use a quenching cloth for brazing operations.
- Have a fire extinguisher available for all brazing operations.

Moving and Storage

Move units in the normal “up” orientation. Units may be moved and stored per the information on the packaging. Do not stack more than three units in total height. Do not attempt to move units while stacked. When the equipment is received, all items should be carefully checked against the bill of lading to be sure all crates and cartons have been received. Examine units for shipping damage, removing the units from the packaging if necessary. Units in question should also be internally inspected. If any damage is noted, the carrier should make the proper notation on the delivery receipt, acknowledging the damage.

Split Unit Location

Locate the split compressor section away from areas that may disturb the customer and in a way that allows easy removal of the access panels and the top of the cabinet. Provide sufficient room to make water, electrical and refrigerant line connections and allow space for service personnel to perform maintenance. The NS split is approved for outdoor installation when properly installed.

Air Coil Location

Refer to the air handler manufacturer’s instructions for the blower coil unit for details on installing the air handling portion of the system.

Condensate Drain

Follow the blower coil manufacturer’s instructions.

Duct System

All blower coil units/air coils must be installed as specified by the manufacturer’s installation instructions; however, the following recommendations should be considered to minimize noise and service problems.

An air filter must always be installed upstream of the air coil on the return air side of the air handler or furnace. If there is limited access to the filter rack for normal maintenance, it is suggested that a return air filter grill be installed. Be sure that the return duct is properly installed and free of leaks to prevent dirt and debris from bypassing the filter and plugging the air coil.

In applications using galvanized metal ductwork, a flexible duct connector is recommended on both the supply and return air plenums to minimize vibration from the blower. To maximize sound attenuation of the unit blower, the supply and return plenums should include an internal duct liner of 1-inch thick glass fiber or be constructed of ductboard. Insulation is usually not installed in the supply branch ducts. Ducts in unconditioned areas should be wrapped with a minimum of 1-inch duct insulation. Application of the unit to uninsulated ductwork in an unconditioned space is not recommended as the unit’s performance will be adversely affected. If the air handler is connected to existing ductwork, a previous check should have

General Installation Information (cont.)

been made to assure that the duct system has the capacity to handle the air required for the unit application. If ducting is too small, as in replacement of heating only systems, larger ductwork should be installed. All existing ductwork should be checked for leaks and repairs made accordingly. The duct systems and diffusers should be sized to handle the design airflow quietly. If air noise or excessive airflow is a problem, the blower speed can be changed to a lower speed to reduce airflow. This will reduce the performance of the unit slightly in heating; however, it will increase the temperature rise across the air coil. Airflow must still meet minimum requirements.

Equipment Selection

The following guidelines should be used when mating an Envision Split to an air handler/coil.

- Select R-410A components only.
- Match the air handler to the air handler coil data table.
- Indoor matching adjustable TXV is factory installed on every air handler/coil. Fixed orifice or cap tube systems should not be used.

Utilizing Existing Coil or Air Handler

It is recommended that a new R-410A air handler be installed with an Envision Split considering the long term benefits of reliability, warranty, etc. versus the short term installation cost savings. However, the existing air handler may be retained provided the following:

- Coil currently is R-410A rated
- Coil uses a TXV. No capillary or fixed orifice systems should be used
- A life expectancy of more than 7 years remaining for the air handler and components

General Installation Information (cont.)

Connection to Air Coil

Figures 1 and 2 illustrate typical Envision Split installations. The table on page 9 shows typical lineset diameters and maximum length. Linesets over 60 feet are not recommended. If the lineset is kinked or deformed and cannot be reformed, the bad section of pipe should be replaced. A restricted lineset will affect unit performance. As in all R-410A equipment, a reversible liquid line filter drier is required to insure all moisture is removed from the system. This drier should be replaced whenever “breaking into” the system for service. All linesets should be insulated with a minimum of 1/2” closed cell insulation. All exterior insulation should be painted with UV resistant paint or covering to insure long insulation life.

Air Handler Installation

Air handlers used with dual capacity units must be capable of operating with a minimum of 2 blower speeds. Refer to the manufacturer’s instructions for the blower coil unit for details on installing the air handling portion of the system. All blower coil units/air coils must be installed as specified by the manufacturer’s installations instructions. However, the following recommendations should be considered to minimize noise and service problems.

An air filter must always be installed upstream of the air coil on the return air side of the air handler or furnace. If there is limited access to the filter rack for normal maintenance, it is suggested that a return air filter grille be installed. Be sure that the return duct is properly installed and free of leaks to prevent dirt and debris from bypassing the filter and plugging the air coil.

Ensure that the line set size is appropriate to the capacity of the unit (refer to page 9). Line sets should be routed as directly as possible, avoiding unnecessary bends or turns. All wall penetrations should be sealed properly. Line set should not come into direct contact with water pipes, floor joists, wall studs, duct work, floors, walls and brick. Line set should not be suspended from joists or studs with a rigid wire or strap which comes into direct contact with the tubing. Wide hanger strips which conform to the shape of the tubing are recommended. Isolate hanger straps from line set insulation by using metal sleeves bent to conform to the shape of insulation. Line set insulation should be pliable, and should completely surround the refrigerant line.

Notes: Improper installation of equipment may result in undesirable noise levels in the living areas.

Figure 1: Typical Split System Application - Remote Blower Coil

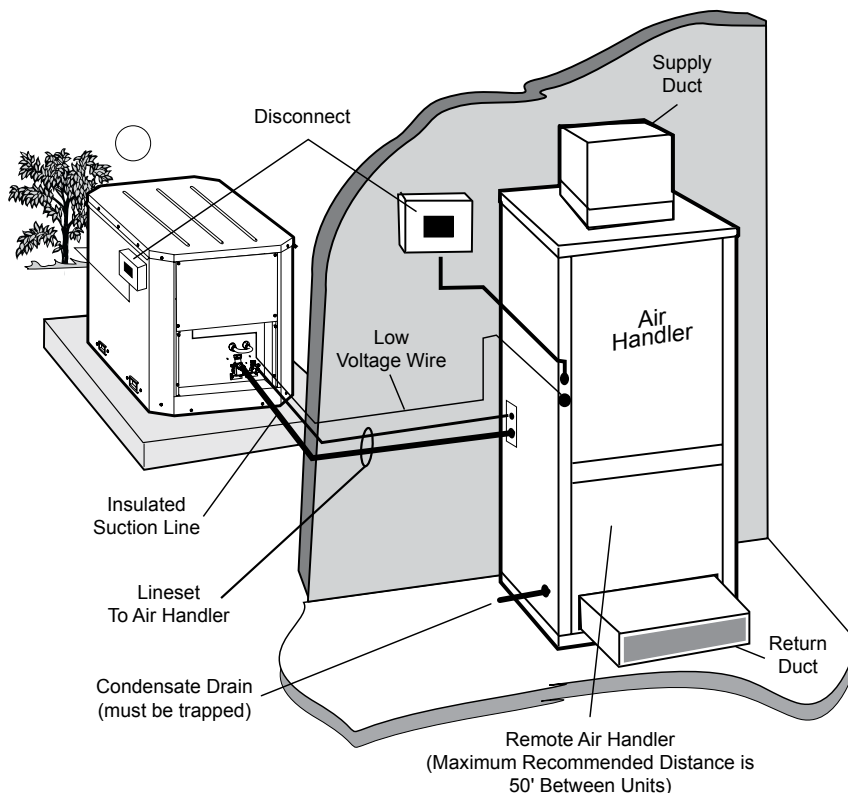

General Installation Information (cont.)

Dual Fuel Systems

Envision units can be connected to fossil fuel furnaces that include an A-coil or slab coil. Dual fuel installations utilize the Envision heat pump for heating until the point that auxiliary heat is called for on the thermostat. At that point, the furnace will be enabled and the heat pump will be disabled. The Envision heat pump provides air conditioning through the furnace's refrigerant coils.

Refer to the furnace manufacturer's installation manual for the furnace installation, wiring and coil insertion. A WaterFurnace Dual Fuel thermostat, a field-installed DPST relay or dual capacity auxiliary heat relay is required. See Figure 2 for typical Dual Fuel application.

In add-on Envision Split applications, the coil should be located in the supply side of the furnace to avoid condensation damage to the furnace heat exchanger. A high temperature limit should be installed upstream of the coil to de-energize the compressor whenever the furnace is operating. Without this switch, the Envision Split will trip out on high pressure. A dual fuel thermostat can remove the Y1 and Y2 calls when a W call is energized to allow gas furnace backup on an Envision Split application. Refer to thermostat wiring on page 15 for details.

Figure 2: Typical Split System Heat Pump Coil Add-On Fossil Fuel Furnace

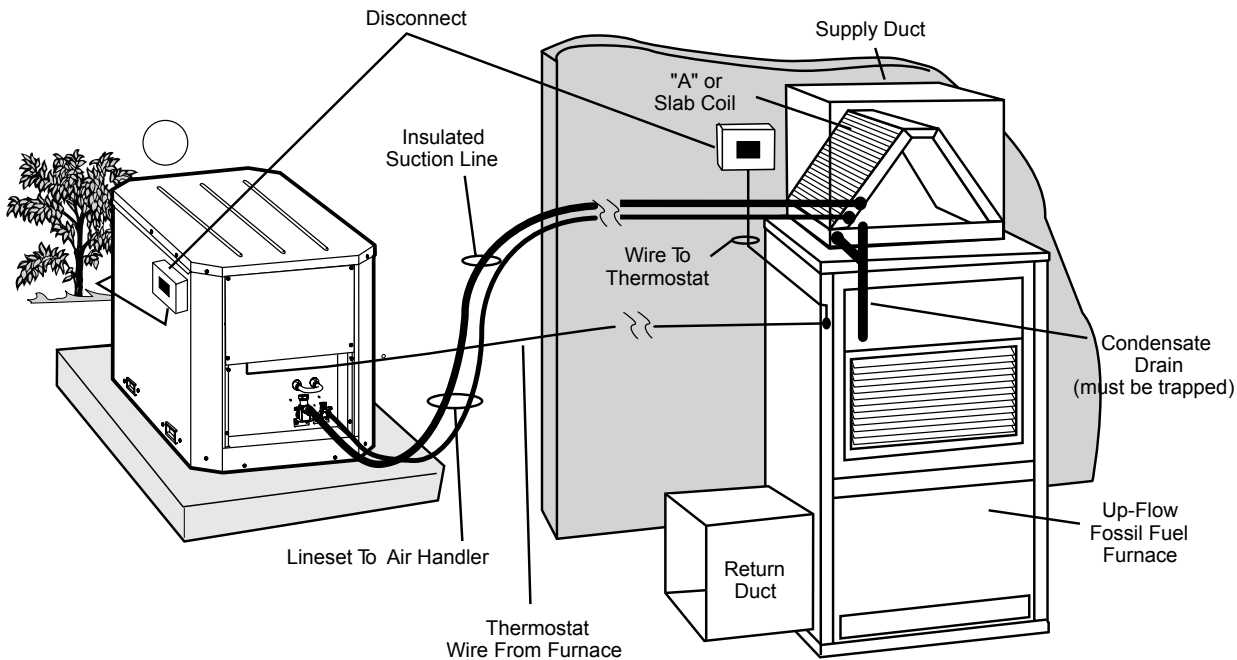

Electrical

General

Be sure the available power is the same voltage and phase as that shown on the unit serial plate. Line and low voltage wiring must be done in accordance with local codes or the National Electric Code, whichever is applicable. See unit electrical data for fuse or circuit breaker sizing information.

Electrical Data

Model	Rated Voltage	Voltage Min/Max	Compressor			HWA Pump FLA	Ext Loop FLA	Total Unit FLA	Min Circ Amp	Max Fuse/HACR
			MCC	RLA	LRA					
026	208-230/60/1	197/253	16.0	10.2	52.0	0.4	5.4	16.0	18.6	25
038	208-230/60/1	197/253	26.0	16.6	82.0	0.4	5.4	22.4	26.6	40
049	208-230/60/1	197/253	33.0	21.1	96.0	0.4	5.4	26.9	32.2	50
064	208-230/60/1	197/253	40.0	25.6	118.0	0.4	5.4	31.4	37.8	60
072	208-230/60/1	197/253	42.5	27.2	150.0	0.4	5.4	33.0	39.8	60

Rated Voltage of 208-230/60/1.

Rev.: 02/20/07

HACR circuit breaker in USA only.

Min/Max Voltage of 197/253.

All fuses Class RK-5.

Thermostat Wiring

Figure 12a: Thermostat Wiring

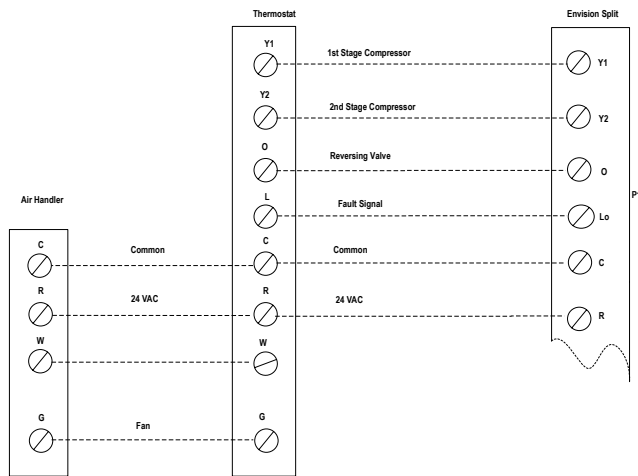

Air Handler transformer must be at least 75 VA.

Figure 12b: Thermostat Wiring for Dual Fuel Applications

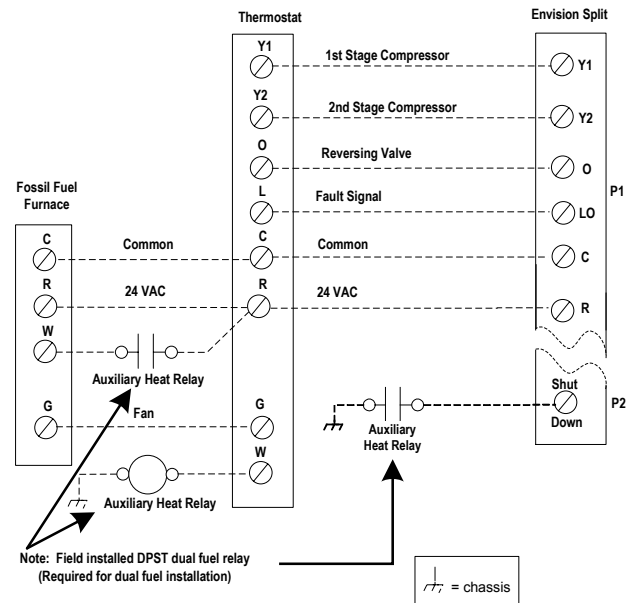

Water Piping

Residential NS split units are supplied standard with brass water connections which will connect to flow center.



CAUTION: Never use flexible hoses smaller than 1-inch inside diameter on the unit and limit hose length to 10 feet per connection. Check carefully for water leaks.



CAUTION: Water piping exposed to outside temperatures may be subject to freezing.

Water Piping

The proper water flow must be provided to each unit whenever the unit operates. To assure proper flow, use pressure/temperature ports to determine the flow rate. These ports should be located at the supply and return water connections on the unit. The proper flow rate cannot be accurately set without measuring the water pressure drop through the refrigerant-to-water heat exchanger.

Closed Loop - Earth coupled Systems (Outdoor Installations)

Locate unit on an air pad with access hole as shown below. When mounting on an existing concrete pad, holes must be bored through to accommodate 1 1/4-inch P.E. pipe with 1/2-inch insulation.

Connecting To Earth Loop

The earth loop trench should be continued directly under the unit as shown in Figure 3. Make the connections to optional fittings from the loop circulator pump(s) and insure proper backfill to support the loop pipe during trench settling. All 1 1/4-inch piping should be insulated with a minimum of 1/2-inch closed cell insulation from below the ground surface to the loop circulator.



IMPORTANT - A freeze protection thermostat is installed in the unit to automatically start loop circulator pump if loop temperature drops below 20°F. Loop freeze protection should also be maintained to the lowest temperature the insulated loop may encounter in the case of power failure.

Flow Center Installation

Flow centers FC1-GL or FC2-GL, as needed, may be internally mounted on the NDS splits. Two stub tubes with barbs are pre connected to the coax. Two tubes with brass fittings, to adapt to the flow center, 2 hoses to connect between the two sets of tubes, and four hose clamps are included with each NDS unit. The brass adapter fittings have plastic swivel connectors and are also internally threaded to accept 1" NPT fittings.

NOTE: For ease of installation, attach provided hoses to coax first and then trim to fit to elbows on flow center.

Figure 3: Typical Split System Outdoor Installation Using Closed Loop

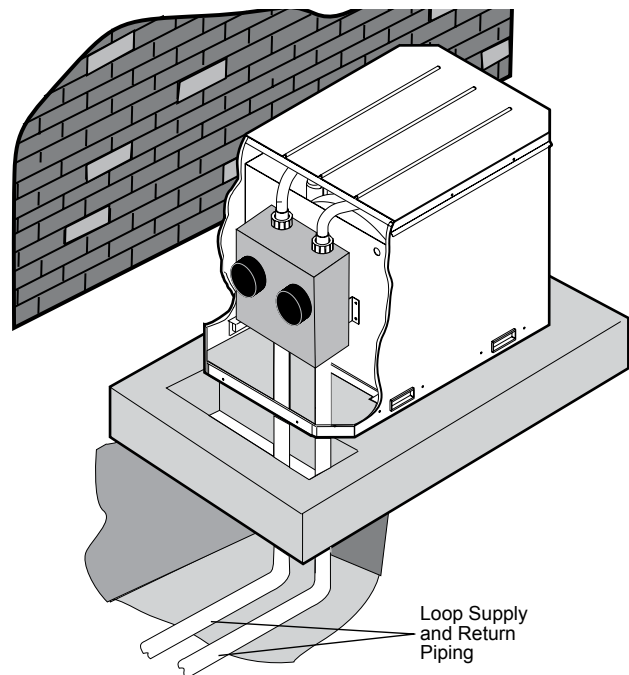

Air Handler Nomenclature

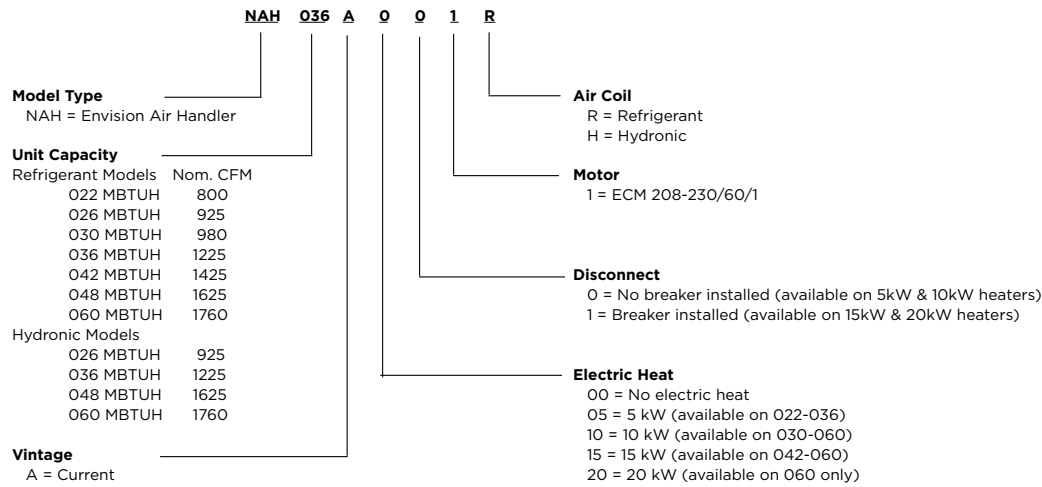

Air Handler Coil Data

Envision Split Model	Matching Air Handler	Coil Surface Area (sq ft.)	FPI	Rows	Tube Diameter
026 - 038	NAH026-36	5.83	12	2	3/8"
049 - 072	NAH048-060	5.83	12	3	3/8"

Line Set Sizes

Unit Size	Air Handler	20 feet		40 feet		60 feet		Factory Charge (oz.)
		Suction	Liquid	Suction	Liquid	Suction	Liquid	
NDS026	NAH026	5/8" OD	3/8" OD	3/4" OD	3/8" OD	3/4" OD	1/2" OD	52
NDS038	NAH036	5/8" OD	3/8" OD	3/4" OD	3/8" OD	3/4" OD	1/2" OD	56
NDS049	NAH048	3/4" OD	3/8" OD	7/8" OD	3/8" OD	7/8" OD	1/2" OD	90
NDS064	NAH060	7/8" OD	1/2" OD	7/8" OD	1/2" OD	1-1/8" OD	1/2" OD	92
NDS072	NAH060	7/8" OD	1/2" OD	7/8" OD	1/2" OD	1-1/8" OD	1/2" OD	104

Notes: Lineset charge for R410A is 0.50 oz. per ft. for 3/8" and 1.0 oz. per ft. for 1/2" tube.

Rev.: 4/1/08

Initial Total System Charge = Factory Split charge + lineset charge + 20 oz, then adjust charge by subcooling and superheat measurements.

Physical Data

Air Handler Model Number (Refrigerant)		NAH022	NAH026	NAH030	NAH036	NAH042	NAH048	NAH060	
Evaporator Coil	Air Coil Total Face Area, ft ² [m ²]	5.83 [0.54]							
	Tube outside diameter - in. [mm]	3/8 [9.52]							
	Number of rows	2			3				
	Fins per inch	12							
	Suction line connection - in. [mm] sweat	5/8 [15.87]				7/8 [22.22]			
	Liquid line connection - in. [mm] sweat	3/8 [9.52]							
Refrigerant		R-410a							
Nominal cooling capacity - tons [kW]		1.8 [6.44]	2.1 [7.59]	2.5 [8.79]	3 [10.55]	3.5 [12.30]	4 [14.06]	5 [17.58]	
Condensate drain connection - (FPT) in. [mm]		3/4 [19.05]							
Blower Wheel Size (Dia x W), in. [mm]		11 x 10 [279 x 254]							
Blower motor type/speeds		ECM variable speed							
Blower motor output - hp [W]		1/2 [373]				1 [746]			
Filter Standard - 1" [51mm] MERV3 disposable, in. [mm]		20 x 24 [508 x 635]							
Electrical characteristics (60hz)		208/230 - 1ph							
Shipping weight - lbs. [kg]		215 [97.52]				220 [99.79]			
Operating weight - lbs. [kg]		195 [88.45]				200 [90.71]			

1/11/08

Air Handler Model Number (Hydronic)		NAH026	NAH036	NAH048	NAH060
Hydronic Coil	Air Coil Total Face Area, ft ² [m ²]	6.94 [0.64]			
	Tube outside diameter - in. [mm]	3/8 [9.52]			
	Number of rows	3			
	Fins per inch	13			
	Water In connection - in. [mm] sweat	7/8 [22.22]			
	Water Out connection - in. [mm] sweat	7/8 [22.22]			
Nominal cooling capacity - tons [kW]		2.1 [7.59]	3 [10.55]	4 [14.06]	5 [17.58]
Condensate drain connection - (FPT) in. [mm]		3/4 [19.05]			
Blower Wheel Size (Dia x W), in. [mm]		11 x 10 [279 x 254]			
Blower motor type/speeds		ECM variable speed			
Blower motor output - hp [W]		1/2 [373]		1 [746]	
Filter Standard - 1" [51mm] MERV3 disposable, in. [mm]		20 x 24 [508 x 635]			
Electrical characteristics (60hz)		208/230 - 1ph			
Shipping weight - lbs. [kg]		220 [99.79]			
Operating weight - lbs. [kg]		200 [90.71]			

3/11/08

Envision Coil Nomenclature

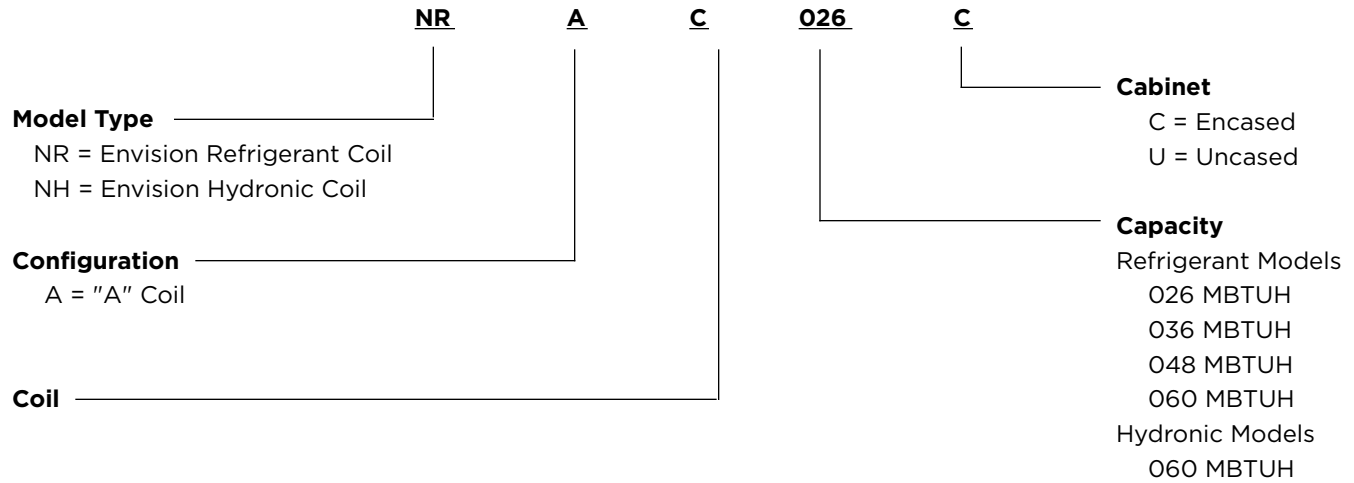

Note: All Refrigerant Coils include TXV. The encased coil cabinet is designed for upflow applications.

Refrigerant Coil Compatibility

Encased/Uncased Coil	Indoor Split Model (Single)	Indoor Split Model (Dual Capacity)	Outdoor Split Model (Dual Capacity)	Recommended Airflow (CFM)
NRAC026*	NSZ022	-		800
NRAC026*	-	NDZ026	NDS026	925
NRAC026*	NSZ030	-	-	980
NRAC036*	NSZ036	-	-	1225
NRAC036*	-	NDZ038	NDS038	1225
NRAC048*	NSZ042	-	-	1425
NRAC048*	NSZ048	-	-	1625
NRAC048*	-	NDZ049	NDS049	1625
NRAC060*	NSZ060	-	-	1760
NRAC060*	-	NDZ064	NDS064	1760
NRAC060*	NSZ070	-	-	1760
NRAC060*	-	NDZ072	NDS072	1760

7/14/08

Heat Recovery Unit for Domestic Hot Water

Service valves have been provided inside the unit for connecting the discharge gas line to a water heating heat recovery unit (see figure 5). To make the connections, close the service valves inside the unit by turning clockwise. Using a recovery canister connect to either of the schrader ports on the DSH service valves and recover the small amount of refrigerant trapped inside of the U-tube. **Prior to brazing ensure that all refrigerant has been removed from U-tube.** Once the refrigerant is removed, it is recommended that the tube be cut at the "U" to remove any excess oil that may be trapped. (This will also allow for easier removal of the tubing with a torch, since each section can be removed independently). **Service valves must be protected to prevent overheating.** Unbrazed the 1/2-inch O.D. U-tube and run tubing from the left hand service valve to the inlet of the heat recovery unit and from the outlet of the heat recovery unit to the right hand of the service valve. Typically the one way discharge line length should be limited to 25-30 feet and line size must be increased depending on unit size and length of run. Follow the instructions supplied with the heat recovery unit for mounting location, water piping, and start up. A typical installation is shown below.

IMPORTANT - Reopen discharge line service valves before starting up unit, but only after leak checking, purging, and evacuating new discharge line.

Figure 5: Service Valves for Heat Recovery Unit Connections

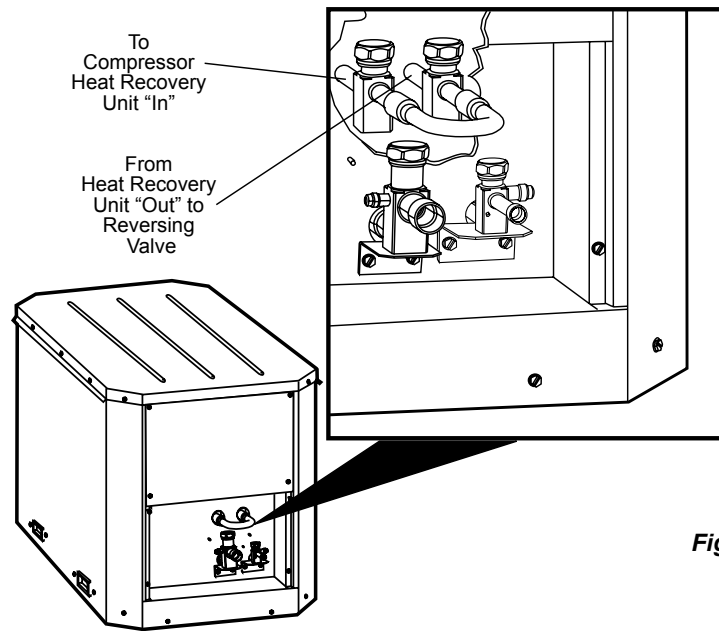

Maximum One-Way Line Length

SIZE	1/2" OD	5/8" OD	3/4" OD
026 - 038	Up to 9 ft.	Up to 25 ft.	Up to 30 ft.
049	Up to 5 ft.	Up to 13 ft.	Up to 30 ft.
064	N/A	Up to 9 ft.	Up to 25 ft.
072	N/A	Up to 6 ft.	Up to 20 ft.

Figure 6: Typical Hot Water Piping Layout

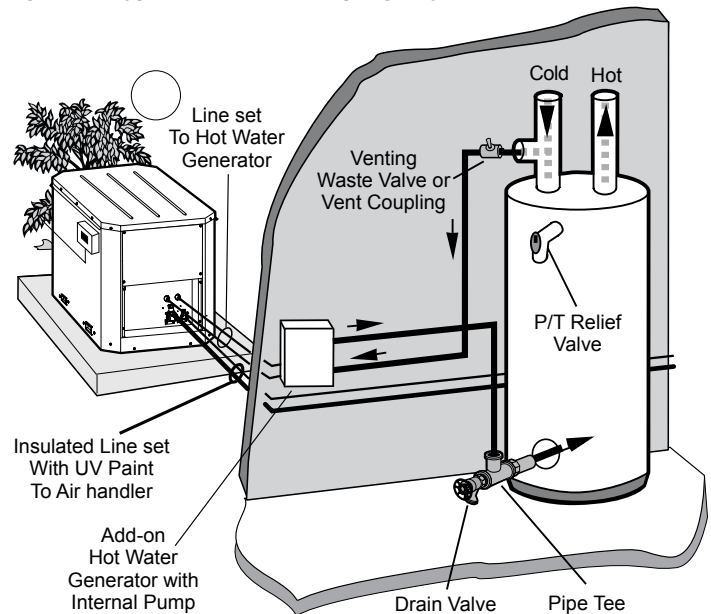

Heat Recovery Connections

To maximize the benefits of the heat recovery a minimum 50-gallon water heater is recommended. For higher demand applications, use an 80-gallon water heater or two 50-gallon water heaters connected in a series as shown below. Electric water heaters are recommended. Make sure all local electrical and plumbing codes are followed when installing a heat recovery.

Note: Under certain conditions, Envision dual capacity units operate with very low refrigerant discharge temperatures, producing little or no water heating capability. This scenario occurs when the unit is operating with cold entering source water (loop or well). Allowing the pump to operate during these conditions actually removes heat from the DHW circulating through the unit. To overcome this, Envision unit microprocessors have been programmed to disengage the desuperheater pump during such conditions. (During low capacity cooling operation, the pump will operate only if the DHW temperature entering the unit is less than the liquid line temperature plus 35° F. During high capacity cooling operation, the pump will operate only if the DHW temperature is less than the liquid line temperature plus 60° F.) Using a preheat tank, as shown in Figure 11, will maximize desuperheater capabilities.

Water Tank Preparation

To install a unit with desuperheater, follow these installation guidelines.

1. Turn off the power to the water heater.
2. Attach a water hose to the water tank drain connection and run the other end of the hose to an open drain or outdoors.
3. Close the cold water inlet valve to the water heater tank.
4. Drain the tank by opening the valve on the bottom of the tank, then open the pressure relief valve or hot water faucet.
5. Flush the tank by opening the cold water inlet valve to the water heater to free the tank of sediments. Close when draining water is clear.
6. Disconnect the garden hose and remove the drain valve from the water heater.
7. Refer to Plumbing Installation and Desuperheater Startup on page 14.



CAUTION: Elements will burn out if energized dry.

Plumbing Installation

1. Inspect the dip tube in the water heater cold inlet for a check valve. If a check valve is present it must be removed or damage to the desuperheater circulator will occur.
2. Remove drain valve and fitting.
3. Thread the 3/4-inch NPT x 3-1/2-inch brass nipple into the water heater drain port.
4. Attach the center port of the 3/4-inch FPT tee to the opposite end of the brass nipple.
5. Attach the 1/2-inch copper to 3/4-inch NPT adaptor to the side of the tee closest to the unit.
6. Install the drain valve on the tee opposite the adaptor.
7. Run interconnecting tubing from the tee to DHW water out.
8. Cut the cold water "IN" line going to the water heater.
9. Insert the reducing solder tee in line with cold water "IN" line as shown.
10. Run interconnecting copper tubing between the unit DHW water "IN" and the tee (1/2-inch nominal).
The recommended maximum distance is 50 feet.
11. To prevent air entrapment in the system, install a vent coupling at the highest point of the interconnecting lines.
12. Insulate all exposed surfaces of both connecting water lines with 3/8-inch wall closed cell insulation.

Note: All plumbing and piping connections must comply with local plumbing codes.

Heat Recovery Startup

1. Close the drain valve to the water heater.
2. Open the cold water supply to the tank.
3. Open a hot water faucet in the building to bleed air from the system. Close when full.
4. Open the pressure relief valve to bleed any remaining air from the tank, then close.
5. If so equipped, unscrew the indicator plug 1 turn on the motor end of the pump until all air is purged from the pump, then tighten the plug. Use vent couplings to bleed air from the lines.
6. Carefully inspect all plumbing for water leaks and correct as required.
7. Before restoring electrical supply to the water heater, adjust the temperature setting on the tank.
 - On tanks with both upper and lower elements, the lower element should be turned down to the lowest setting, approximately 100°F. The upper element should be adjusted to 120°F to 130°F. Depending upon the specific needs of the customer, you may want to adjust the upper element differently.
 - On tanks with a single element, lower the thermostat setting to 120°F.
8. After the thermostat(s) is adjusted, replace the access cover and restore electrical supply to the water heater.
9. Make sure that any valves in the desuperheater water circulating circuit are open.
10. Turn on the unit to first stage heating.
11. The DHW pump should be running. When the pump is first started, open the inspection port 1 turn (if equipped) until water dribbles out, then replace. Allow the pump to run for at least five minutes to ensure that water has filled the circulator properly. Be sure the switch for the DHW pump (SW4) is "ON". The DHW "OFF" LED on the unit should not be illuminated.
12. The temperature difference between the water entering and leaving the desuperheater should be 5°F to 15°F. The water flow should be approximately 0.4 GPM per ton of nominal cooling.
13. Allow the unit to heat water for 15 to 20 minutes to be sure operation is normal.



CAUTION: Never operate the DHW circulating pump while dry. If the unit is placed in operation before the desuperheater piping is connected, be sure that the pump switch is set to the OFF position.

Wiring Schematics

Envision Series - Dual Capacity Split Wiring Schematic - 208-230/60/1

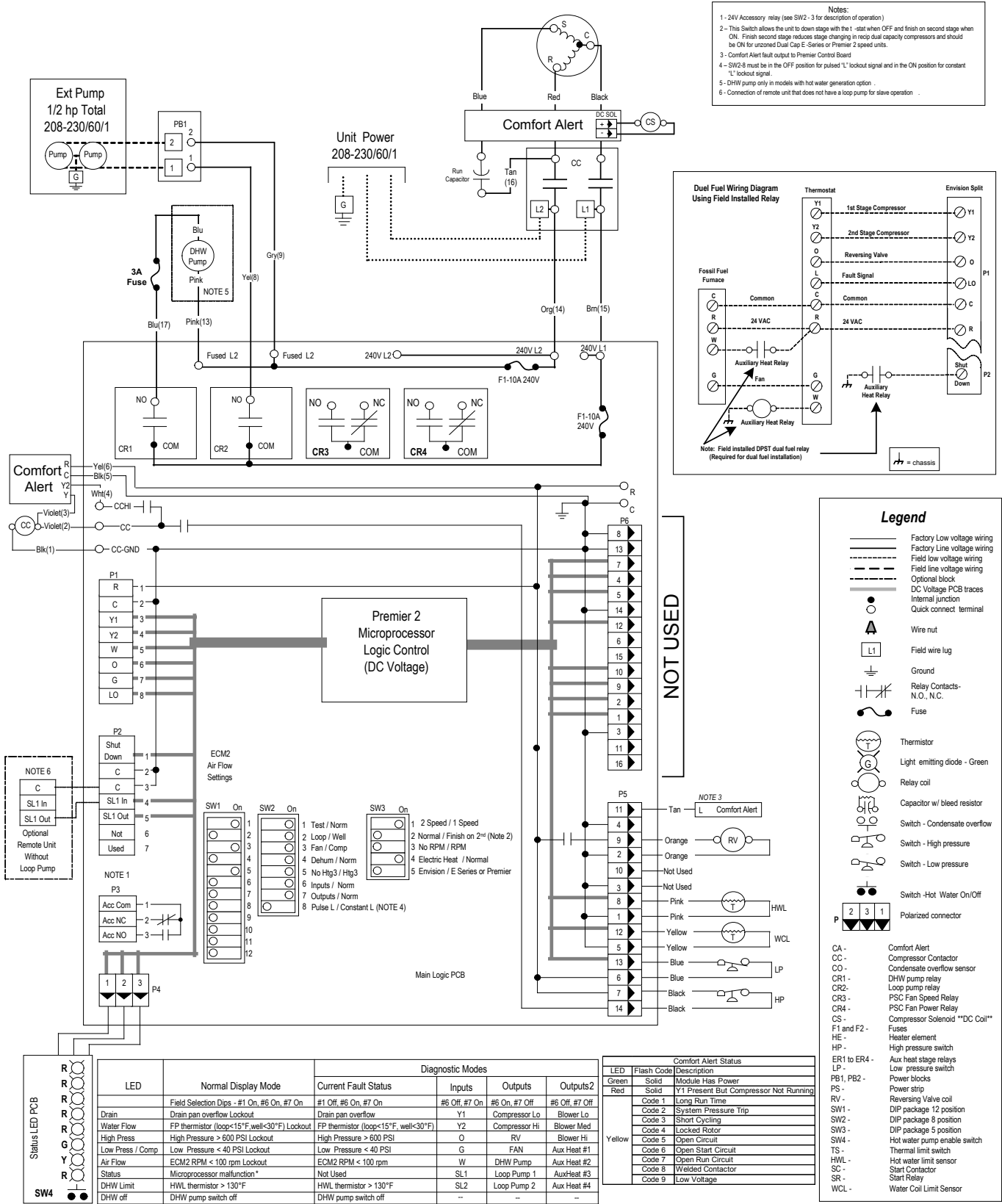

Microprocessor Control

Startup

The unit will not operate until all the inputs and safety controls are checked for normal conditions. At first power-up, a four-minute delay is employed before the compressor is energized.

Component Sequencing Delays

Components are sequenced and delayed for optimum space conditioning performance.

Accessory Relay

An accessory relay on the control board allows for field connection of solenoid valves, electronic air cleaners, etc. The accessory relay has a normally open output and a normally closed output.

Short Cycle Protection

The control employs a minimum "off" time of four minutes to provide for short cycle protection of the compressor.

Shutdown Mode

A 24VAC common signal to the "shutdown" input on the control board puts the unit into shutdown mode. Compressor, hot water pump and fan operation are suspended.

Safety Controls

The Envision control receives separate signals for a high pressure switch for safety, a low pressure switch to prevent loss of charge damage, and a low suction temperature thermistor for freeze sensing. Upon a continuous 30-second measurement of the fault (immediate for high pressure), compressor operation is suspended, the appropriate lockout LED begins flashing. (Refer to the "Fault Retry" section below.)

Testing

The Envision control allows service personnel to shorten most timing delays for faster diagnostics. (Refer to the Field Selection DIP switch SW2-1 on page 21.)

Fault Retry

All faults are retried twice before finally locking the unit out. An output signal is made available for a fault LED at the thermostat. The "fault retry" feature is designed to prevent nuisance service calls.

Diagnostics

The Envision control board allows all inputs and outputs to be displayed on the LEDs for fast and simple control board diagnosis. (Refer to the Field Selection DIP Switch SW2-1 on page 21.)

Hot Water High Limit (Domestic Hot Water Option)

This mode occurs when the hot water input temperature is at or above 130°F for 30 continuous seconds. The DHW limit status LED on the unit illuminates and the hot water pump de-energizes. Hot water pump operations resume on the next compressor cycle or after 15 minutes of continuous compressor operation during the current thermostat demand cycle.

Hot Water Justification

Since compressor hot gas temperature is dependant on loop temperature in cooling mode, loop temperatures may be too low to allow proper heating of water. The control will monitor water and refrigerant temperatures to determine if conditions are satisfactory for heating water. The DHW limit status LED on the unit illuminates when conditions are not favorable for heating water.

Heating Operation Heat, 1st Stage (Y1)

The fan motor is started on low speed immediately (PSC ON), the loop pump is energized 5 seconds after the "Y1" input is received, and the compressor is energized on low capacity 10 seconds after the "Y1" input. The fan is switched to medium speed 15 seconds after "Y1" input (ECM only). The hot water pump is cycled 30 seconds after the "Y1" input.

Heat, 2nd Stage (Y1,Y2) Dual Capacity Units

The second stage compressor will be activated 5 seconds after receiving a "Y2" input as long as the minimum first stage compressor run time of 1 minute has expired. The ECM blower changes from medium to high speed 15 seconds after the "Y2" input.

The Comfort Alert will delay the second stage compressor until 5 seconds after it receives a "Y2" from the board.

Heat, 3rd Stage (Y1,Y2,W) Dual Capacity Units

The hot water pump is de-energized which directs all heat to satisfy the thermostat. The 1st stage of resistance heat is energized 10 seconds after "W" input, and with continuous 3rd stage demand, the additional stages of resistance heat engage sequentially every 5 minutes.

Emergency Heat (W only)

The fan is started on high speed, and the first stage of resistance heat is energized 10 seconds after the "W" input. Continuing demand will engage the additional stages of resistance heat sequentially every 2 minutes.

Cooling Operation

In all cooling operations, the reversing valve directly tracks the "O" input. Thus, anytime the "O" input is present, the reversing valve will be energized.

Cool, 1st Stage (Y1,O)

The blower motor and hot water pump are started immediately, the loop pump(s) is energized 5 seconds after the "Y1" input is received. The compressor will be energized (on low capacity for Dual Capacity units) 10 seconds after the "Y1" input. The ECM blower will shift from low to medium speed 15 seconds after the "Y1" input (85% of medium speed if in dehumidification mode).

Cool, 2nd Stage (Y1, Y2, O) Dual Capacity Units

The second stage compressor will be activated 5 seconds after receiving a "Y2" input as long as the minimum first stage compressor run time of 1 minute has expired. The ECM blower changes to high speed 15 seconds after the "Y2" input (85% of

Microprocessor Control (cont.)

high speed if in dehumidification mode). The Comfort Alert will delay the second stage compressor until 5 seconds after it receives a “Y2” from the board.

Fan (G only)

The fan starts on low speed (PSC ON). Regardless of fan input “G” from thermostat, the fan will remain on low speed for 30 seconds at the end of each heating, cooling or emergency heat cycle.

Lockout Conditions

During lockout mode, the appropriate unit and thermostat lockout LEDs will illuminate. The compressor, loop pump, hot water pump, and accessory outputs are de-energized. The fan will continue to run on low speed. If the thermostat calls for heating, emergency heat operation will occur.

Comfort Alert lockouts cannot be reset at the thermostat. All other lockout modes can be reset at the thermostat after turning the unit off, then on, which restores normal operation but keeps the unit lockout LED illuminated. Interruption of power to the unit will reset a lockout without a waiting period and clear all lockout LEDs.

High Pressure

This lockout mode occurs when the normally closed safety switch is opened momentarily (set at 600 PSI).

Low Pressure

This lockout mode occurs when the normally closed low pressure switch is opened for 30 continuous seconds (set at 40 PSI). A low pressure fault may also be indicated when a Comfort Alert lockout has occurred.

Freeze Sensing (Water Flow)

This lockout mode occurs when the freeze thermistor temperature is at or below the selected freeze point (well 30°F or loop 15°F) for 30 continuous seconds.

Operation Logic Data

OPERATION LOGIC	HEATING				COOLING		FAN ON	SL1 - IN ON	SL2 - IN ON
	STG1	STG2	STG3	EMERG	STG1	STG2			
DUAL CAPACITY UNITS									
Compressor-Lo	On	Off	Off	Off	On	Off	-	-	-
Compressor-Hi	Off	On	On	Off	Off	On	-	-	-
Rev Valve	Off	Off	Off	Off	On	On	-	-	-
Loop Pump	On	On	On	Off	On	On	-	On	-
DHW Pump	On	On	Off	Off	On	On	-	-	-
Secondary 1- Out	On	On	On	Off	On	On	-	-	-
Secondary 2- Out	Off	On	On	Off	Off	On	-	-	-
Emerg LED	Off	Off	Off	On	Off	Off	-	-	-
T-Stat Signal	Y1	Y1, Y2	Y1, Y2, W	W	Y1, O	Y1, Y2, O	G	-	-

DIP Switch Settings

DIP SWITCH NUMBER		DESCRIPTION	OFF POSITION	ON POSITION
SW1	N/A	NOT USED	N/A	N/A
SW2	1	Service/Test Mode - Allows control of "NORM" or "TEST" operational modes. Test mode accelerates most timing functions 16 times to allow faster troubleshooting. Test mode also allows viewing the "CURRENT" status of the fault inputs on the LED display.	Test	Norm
	2	Freeze Sensing Setting Allows field selection of freeze thermistor fault sensing temperatures for well water (30°F) or antifreeze-protected (15°F) earth loops.	Loop (Protection 15° F)	Well (Protection 30° F)
	3	Accessory Relay Allows field selection of the accessory relay to operate with the compressor or fan.	Fan	Comp
	4	NOT USED	N/A	N/A
	5	NOT USED	N/A	N/A
	6	Input Diagnostics - Allows viewing the inputs from the thermostat to the control board such as Y1, Y2, O, G, W, SL1-In on the LED display.	Diagnostic Inputs viewed at LEDs	Normal Display viewed at LEDs
	7	Output Diagnostics - Allows viewing the outputs from the control board such as the compressor, reversing valve, blower, hot water pump, and loop pump on the LED display.	Diagnostic Outputs viewed at LEDs	Normal Display viewed at LEDs
	8	Thermostat Selection Configures the control for a pulsed lockout signal (ComforTalk and FaultFlash thermostats) or continuous 5 VAC lockout signal.	Pulsed "L" signal	Continuous "L" signal
SW3	1	Single or Dual Capacity Operation	Dual Cap	1 Speed
	2	Zoned/Finish on Second Stage This switch allows the unit to down stage with the thermostat when off and finish with second stage when on. Finish on second stage reduces stage changing in reciprocating dual capacity compressors.	Normal - All other systems	Finish on 2nd Unzoned Dual Capacity E-Series or Premier 2 speed
	3	ECM Fan Monitoring - Set for No PRM on split systems	No RPM	RPM
	4	NOT USED	N/A	N/A
	5	On dual capacity units this switch allows stage change: on the fly when off, and 1 minute delay when on. A delay is required on all reciprocating dual capacity units.	Envision	E-Series or Premier

Refrigeration

The Envision series comes with a holding charge. The charge must be adjusted in the field based on performance. Refrigeration piping on the split consists of installing a brazed copper line set between the blower coil unit and the unit's split compressor section. To select the proper tube diameters for the installation, refer to the table on page 9. Line sets over 60 feet long are not recommended because of oil return and pressure drop problems. The suction line must always be insulated. Handle and route the line sets carefully to avoid kinking or bending the tubes. If the line set is kinked or distorted and it cannot be formed back into its original shape, the bad portion of the pipe should be replaced. A restricted line set will affect the performance of the system.

Connection to Air Coil

Figures 1 and 2 illustrate typical Envision Split installations. The table on page 9 shows typical lineset diameters and maximum length. As in all R-410A equipment, a reversible liquid line filter drier is required to insure all moisture is removed from the system. This drier should be replaced whenever "breaking into" the system for service. All linesets should be insulated with a minimum of 1/2" closed cell insulation. All insulation should be painted with UV resistant paint or covering to insure long insulation life.

Fasten the copper line set to the blower coil unit as instructed by the coil installation instructions shown in Figure 14. Nitrogen should be bled through the system at 2 to 3 PSI to prevent oxidation inside the refrigerant tubing. Use a low silver phos-copper braze alloy on all brazed connections.

Braze line set to the service valve stubs on the inside front of the split cabinet as shown in Figure 13. Nitrogen should be bled through the system at 2 to 3 PSI to prevent oxidation contamination. Use a low silver phos-copper braze alloy on all brazed connections. Envision split units are shipped with a factory charge and service valves are not to be opened until the line set has been leak tested, purged and evacuated. Schrader cores should be removed before brazing. A heat sink should be used on the service valves and TXV to prevent damage caused by excessive heat.

Figure 13: Typical Split System Refrigerant Line Connections

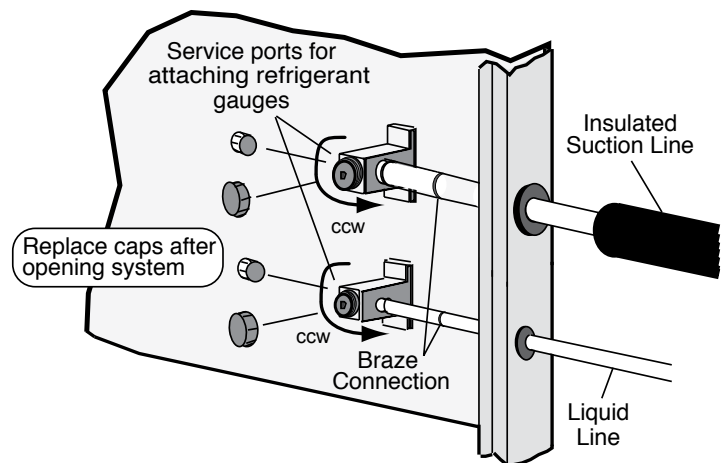

Refrigeration (continued)

Leak Testing

The refrigeration line set must be pressurized and checked for leaks before purging and charging the unit. To pressurize the line set, attach refrigerant gauges to the service ports and add an inert gas (nitrogen or dry carbon dioxide) until pressure reaches 60 to 90 PSIG. Never use oxygen or acetylene to pressure test. Use an electronic leak detector or a good quality bubble solution to detect leaks on all connections made in the field. Check the service valve ports and stem for leaks and all connections made in the field. If a leak is found, repair it and repeat the above steps. For safety reasons do not pressurize the system above 150 psi. Purge pressure from line set. The system is now ready for evacuating and charging.

System Evacuation

Ensure that the line set and air coil are evacuated before opening service valves to the split unit. The line set must be evacuated to at least 200 microns to remove the moisture and air that may still be in the line set and coil. Evacuate the system through both service ports to prevent false readings on the gauge because of pressure drop through service ports.

Initial System Charge Calculation

The Envision unit comes with a factory pre-charge. This volume is not sufficient to run the system. Additional refrigerant must be added for the lineset. This additional charge added to the factory pre-charge of the Envision unit should be estimated using the following equation:

$$\text{Addition to Factory Charge} = (\text{lineset length} \times \text{oz. per ft}) + (20 \text{ oz. for accumulator})$$

The lineset charge should be calculated by multiplying the length times 0.5 oz./ft for 3/8" liquid line and 1.0 oz./ft for 1/2" liquid line in R-410A systems. The suction line will not hold 'liquid' and can be ignored for the calculation. This should result in a slightly under-charged unit exhibiting low subcooling and high superheat. As charge is added, the subcooling should rise and the superheat should fall until 8-16 degrees of superheat is reached when the TXV should be metering the system. See operating details in the startup section of this manual for exact superheat and subcooling values.

Example: 038 with 40 foot of 3/8" liquid line.

$$\begin{aligned} \text{Additional to be added} &= (40 \text{ ft} \times 0.5 \text{ oz./ft}) + (20 \text{ oz. for accumulator}) \\ &= 40 \text{ oz.} \end{aligned}$$

Solution: 40 oz. should be added to the existing 56 oz. of factory charge as an initial charge.

Charging the System

Charge Method – After purging and evacuating the line set, fully open the service valves counterclockwise. Add R-410A (liquid) into the liquid line service port until the pressure in the system reaches approximately 200 PSIG. Never add liquid refrigerant into the suction side of a compressor. Start the unit and measure superheat and subcooling. Keep adding refrigerant until the unit meets the superheat and subcooling values on page 24.

Checking Superheat and Subcooling

Determining Superheat

1. Measure the temperature of the suction line at the point where the expansion valve bulb is clamped.
2. Determine the suction pressure in the suction line by attaching refrigeration gauges to the schrader connection on the suction side of the compressor.
3. Convert the pressure obtained in Step 2 to the saturation temperature by using the R-410A Pressure/Temperature Conversion Chart on page 23.
4. Subtract the temperature obtained in Step 3 from Step 1. The difference is the amount of superheat for the unit. Refer to tables on page 24 for superheat ranges at specific entering water conditions.

Superheat Adjustment

TXV's are factory set to a specific superheat; however, the superheat should be adjusted for the application. To adjust the TXV to other superheat settings:

1. Remove the seal cap from the bottom of the valve.
2. Turn the adjustment screw clockwise to increase superheat and counterclockwise to decrease superheat. One complete 360° turn changes the superheat approximately 3-4°F, regardless of refrigerant type. You may need to allow as much as 30 minutes after the adjustment is made for the system to stabilize.

Refrigeration (continued)

1. Once the proper superheat setting has been achieved, replace and tighten the seal cap.

Warning: There are 8 total (360°) turns on the superheat adjustment stem from wide open to fully closed. When adjusting the superheat stem clockwise (superheat increase) and the stop is reached, any further clockwise turning adjustment will damage the valve.

Determining Subcooling

1. Measure the temperature of the liquid line on the small refrigerant line (liquid line) just outside the split cabinet. This location will be adequate for measurement in both modes unless a significant temperature drop in the liquid line is anticipated.
2. Measure the liquid line pressure by attaching refrigerant gauges to the schrader connection on the liquid line service valve.
3. Convert the pressure obtained in Step 2 to the saturation temperature by using the R-410A Pressure/Temperature Conversion Chart on page 23.
4. Subtract the temperature in Step 1 from the temperature in Step 3. The difference will be the subcooling value for that unit. Refer to the tables on page 24 for subcooling ranges at specific enter water conditions.

Pressure/Temperature Conversion Chart for R-410A

PRESSURE (PSIG)	TEMP °F	PRESSURE (PSIG)	TEMP °F	PRESSURE (PSIG)	TEMP °F	PRESSURE (PSIG)	TEMP °F	PRESSURE (PSIG)	TEMP °F
60	8.5	180	63.5	300	96.3	420	120.6	540	140.0
62	9.9	182	64.2	302	96.8	422	120.9	542	140.3
64	11.2	184	64.8	304	97.2	424	121.3	544	140.6
66	12.5	186	65.5	306	97.7	426	121.6	546	140.9
68	13.8	188	66.1	308	98.1	428	122.0	548	141.2
70	15.1	190	66.8	310	98.6	430	122.3	550	141.4
72	16.3	192	67.4	312	99.0	432	122.7	552	141.7
74	17.5	194	68.0	314	99.5	434	123.0	554	142.0
76	18.7	196	68.7	316	99.9	436	123.4	556	142.3
78	19.8	198	69.3	318	100.4	438	123.7	558	142.6
80	21.0	200	69.9	320	100.8	440	124.1	560	142.9
82	22.1	202	70.5	322	101.2	442	124.4	562	143.2
84	23.2	204	71.1	324	101.7	444	124.8	564	143.5
86	24.3	206	71.7	326	102.1	446	125.1	566	143.7
88	25.4	208	72.3	328	102.5	448	125.4	568	144.0
90	26.5	210	72.9	330	103.0	450	125.8	570	144.3
92	27.5	212	73.5	332	103.4	452	126.1	572	144.6
94	28.6	214	74.1	334	103.8	454	126.5	574	144.9
96	29.6	216	74.7	336	104.2	456	126.8	576	145.1
98	30.6	218	75.3	338	104.7	458	127.1	578	145.4
100	31.6	220	75.8	340	105.1	460	127.5	580	145.7
102	32.6	222	76.4	342	105.5	462	127.8	582	146.0
104	33.5	224	77.0	344	105.9	464	128.1	584	146.2
106	34.5	226	77.5	346	106.3	466	128.5	586	146.5
108	35.4	228	78.1	348	106.7	468	128.8	588	146.8
110	36.4	230	78.7	350	107.2	470	129.1	590	147.1
112	37.3	232	79.2	352	107.6	472	129.4	592	147.3
114	38.2	234	79.8	354	108.0	474	129.8	594	147.6
116	39.1	236	80.3	356	108.4	476	130.1	596	147.9
118	40.0	238	80.9	358	108.8	478	130.4	598	148.2
120	40.9	240	81.4	360	109.2	480	130.7	600	148.4
122	41.7	242	81.9	362	109.6	482	131.1	602	148.7
124	42.6	244	82.5	364	110.0	484	131.4	604	149.0
126	43.4	246	83.0	366	110.4	486	131.7	606	149.2
128	44.3	248	83.5	368	110.8	488	132.0	608	149.5
130	45.1	250	84.1	370	111.2	490	132.3		
132	45.9	252	84.6	372	111.6	492	132.7		
134	46.7	254	85.1	374	112.0	494	133.0		
136	47.5	256	85.6	376	112.3	496	133.3		
138	48.3	258	86.1	378	112.7	498	133.6		
140	49.1	260	86.6	380	113.1	500	133.9		
142	49.9	262	87.1	382	113.5	502	134.2		
144	50.7	264	87.7	384	113.9	504	134.5		
146	51.5	266	88.2	386	114.3	506	134.9		
148	52.2	268	88.7	388	114.7	508	135.2		
150	53.0	270	89.2	390	115.0	510	135.5		
152	53.7	272	89.6	392	115.4	512	135.8		
154	54.5	274	90.1	394	115.8	514	136.1		
156	55.2	276	90.6	396	116.2	516	136.4		
158	55.9	278	91.1	398	116.5	518	136.7		
160	56.6	280	91.6	400	116.9	520	137.0		
162	57.4	282	92.1	402	117.3	522	137.3		
164	58.1	284	92.6	404	117.6	524	137.6		
166	58.8	286	93.0	406	118.0	526	137.9		
168	59.5	288	93.5	408	118.4	528	138.2		
170	60.2	290	94.0	410	118.7	530	138.5		
172	60.8	292	94.5	412	119.1	532	138.8		
174	61.5	294	94.9	414	119.5	534	139.1		
176	62.2	296	95.4	416	119.8	536	139.4		
178	62.9	298	95.8	418	120.2	538	139.7		

Unit Operating Parameters

Dual Capacity Models

First Stage Operation

Entering Water Temp °F	Water Flow GPM/Ton	Cooling -- No Desuperheater					
		Suction Pressure PSIG	Discharge Pressure PSIG	Superheat	Subcooling	Water Temp Rise °F	Air Temp Drop °F DB
50	1.5	125-140	205-225	9-15	3-10	17-21	17-23
	3.0	120-135	190-210	9-15	3-10	8-12	17-23
70	1.5	135-145	260-290	9-18	5-11	16-20	17-23
	3.0	126-143	230-250	9-18	5-11	9-13	17-23
90	1.5	138-150	315-345	8-14	7-14	14-20	17-23
	3.0	136-148	300-330	8-14	7-14	8-12	17-23

Entering Water Temp °F	Water Flow GPM/Ton	Heating -- No Desuperheater					
		Suction Pressure PSIG	Discharge Pressure PSIG	Superheat	Subcooling	Water Temp Drop °F	Air Temp Rise °F DB
30	1.5	76-89	260-325	7-12	4-16	5-9	12-16
	3.0	80-93	265-330	7-12	4-16	3-7	14-18
50	1.5	105-120	295-355	7-14	4-16	7-11	18-22
	3.0	110-125	300-360	7-14	4-16	5-9	20-24
70	1.5	135-155	330-385	9-14	7-15	8-12	24-28
	3.0	140-160	335-390	9-14	7-15	6-10	22-30

Second Stage Operation

Entering Water Temp °F	Water Flow GPM/Ton	Cooling -- No Desuperheater					
		Suction Pressure PSIG	Discharge Pressure PSIG	Superheat	Subcooling	Water Temp Rise °F	Air Temp Drop °F DB
50	1.5	120-135	215-235	10-16	3-11	17-21	17-23
	3.0	115-130	200-220	10-16	3-11	8-12	17-23
70	1.5	121-136	270-305	9-15	5-12	16-20	17-23
	3.0	118-133	255-285	9-15	5-12	9-13	17-23
90	1.5	126-143	325-360	8-14	7-15	14-20	17-23
	3.0	123-140	310-340	8-14	7-15	8-12	17-23

Entering Water Temp °F	Water Flow GPM/Ton	Heating -- No Desuperheater					
		Suction Pressure PSIG	Discharge Pressure PSIG	Superheat	Subcooling	Water Temp Drop °F	Air Temp Rise °F DB
30	1.5	72-81	280-330	6-12	10-20	5-9	12-16
	3.0	76-85	285-335	6-12	10-20	3-7	14-18
50	1.5	100-115	305-370	6-12	6-18	7-11	18-22
	3.0	105-120	310-375	6-12	6-18	5-9	20-24
70	1.5	133-147	340-400	7-14	4-15	8-12	24-28
	3.0	138-152	345-405	7-14	4-15	6-10	22-30

Note: Cooling performance based on entering air temperatures of 80° F DB, 67° F WB.

Heating performance based on entering air temperature of 70° F DB.

Pressure Drop and Recommended Flow Rates

Dual Capacity

Model	GPM	Pressure Drop (psi)				
		30°F	50°F	70°F	90°F	110°F
026 full load	4	1.4	1.3	1.2	1.1	1.0
	6	2.8	2.6	2.4	2.3	2.1
	8	4.7	4.4	4.1	3.8	3.5
	10	7.0	6.6	6.2	5.8	5.3
026 part load	3	0.8	0.7	0.7	0.7	0.6
	5	2.0	1.8	1.7	1.6	1.5
	7	3.6	3.4	3.2	3.0	2.8
	9	5.8	5.5	5.1	4.8	4.4
038 full load	5	1.2	1.2	1.1	1.0	1.0
	7	2.2	2.1	1.9	1.8	1.7
	9	3.4	3.2	3.0	2.8	2.6
	11	4.9	4.6	4.3	4	3.7
038 part load	4	0.9	0.8	0.8	0.7	0.7
	6	1.7	1.6	1.5	1.4	1.3
	8	2.8	2.6	2.5	2.3	2.1
	10	4.2	3.9	3.7	3.4	3.2
049 full load	6	1.2	1.2	1.1	1.0	1.0
	9	2.4	2.2	2.1	2.0	1.8
	12	3.9	3.6	3.4	3.2	2.9
	15	5.7	5.3	5	4.7	4.3
049 part load	5	0.9	0.9	0.8	0.8	0.7
	8	2.0	1.8	1.7	1.6	1.5
	11	3.4	3.1	2.9	2.8	2.5
	14	5.0	4.7	4.4	4.1	3.8
064 full load	8	1.8	1.7	1.6	1.4	1.3
	12	3.8	3.5	3.3	3.0	2.8
	16	6.5	6.0	5.6	5.2	4.8
	20	9.7	9.1	8.5	8.0	7.4
064 part load	6	1.0	0.9	0.9	0.8	0.8
	10	2.6	2.5	2.3	2.1	2.0
	14	5.0	4.7	4.4	4.1	3.8
	18	8.1	7.6	7.1	6.6	6.1
072 full load	12	3.2	3.0	2.8	2.6	2.4
	15	4.5	4.2	4.0	3.7	3.4
	18	6.0	5.7	5.3	4.9	4.6
	21	7.8	7.3	6.8	6.4	5.9
072 part load	10	2.3	2.1	2.0	1.9	1.7
	13	3.6	3.3	3.0	2.8	2.6
	16	5.0	4.6	4.3	4.0	3.7
	19	6.5	6.2	5.8	5.4	5.0

5/30/06

Unit Startup

Before Powering Unit, Check The Following:

- High voltage is correct and matches nameplate.
- Fuses, breakers and wire size correct.
- Low voltage wiring complete.
- Piping completed and water system cleaned and flushed.
- Air is purged from closed loop system.
- Isolation valves are open, water control valves or loop pumps wired.
- Condensate line open and correctly pitched.
- Transformer switched to 208V if applicable.
- DIP switches are set correctly.
- DHW pump switch is "OFF" unless piping is completed and air has been purged.
- Blower rotates freely.
- Blower speed correct.
- Air filter/cleaner is clean and in position.
- Service/access panels are in place.
- Return air temperature is between 50-80°F heating and 60-95°F cooling.
- Check air coil cleanliness to insure optimum performance. Clean as needed according to maintenance guidelines. To obtain maximum performance the air coil should be cleaned before startup. A 10-percent solution of dishwasher detergent and water is recommended for both sides of coil, a thorough water rinse should follow.

Startup Steps

Notes: Complete the Equipment Start-Up/Commissioning Check Sheet during this procedure. Refer to thermostat operating instructions and complete the startup procedure.

1. Initiate a control signal to energize the blower motor. Check blower operation.
2. Initiate a control signal to place the unit in the cooling mode. Cooling setpoint must be set below room temperature.
3. First stage cooling will energize after a time delay.
4. Be sure that the compressor and water control valve or loop pump(s) are activated.
5. Verify that the water flow rate is correct by measuring the pressure drop through the heat exchanger using the P/T plugs and comparing to unit capacity data in specification catalog.
6. Check the temperature of both the supply and discharge water (see page 24).
7. Check for an air temperature drop of 15°F to 25°F across the air coil, depending on the fan speed and entering water temperature.
8. Decrease the cooling set point several degrees and verify high-speed blower operation.
9. Adjust the cooling setpoint above the room temperature and verify that the compressor and water valve or loop pumps deactivate.
10. Initiate a control signal to place the unit in the heating mode. Heating set point must be set above room temperature.
11. First stage heating will energize after a time delay.
12. Check the temperature of both the supply and discharge water (see page 24).
13. Check for an air temperature rise of 20°F to 35°F across the air coil, depending on the fan speed and entering water temperature.
14. If auxiliary electric heaters are installed, increase the heating setpoint until the electric heat banks are sequenced on. All stages of the auxiliary heater should be sequenced on when the thermostat is in the Emergency Heat mode. Check amperage of each element.

15. Adjust the heating setpoint below room temperature and verify that the compressor and water valve or loop pumps deactivate.
16. During all testing, check for excessive vibration, noise or water leaks. Correct or repair as required.
17. Set system to desired normal operating mode and set temperature to maintain desired comfort level.
18. Instruct the owner/operator in the proper operation of the thermostat and system maintenance.

Notes: Be certain to fill out and forward all warranty registration papers.

Final Evaluation

After the initial check of superheat/subcooling values in the heating mode, shut off the unit and allow it to sit 3 to 5 minutes until pressures equalize. Restart the unit in the cooling mode and check the values against those in tables on page 24. If the unit performs satisfactorily, charging is complete. If the unit does not perform to specifications, the charge may need to be readjusted until the values are close. Adding refrigerant will increase subcooling. Recovering some of the refrigerant will decrease subcooling and increase superheat. If the superheat/subcooling values are still not close to the specifications in tables on page 24, analyze refrigerant circuit operation.

Unit Startup/Troubleshooting

Heating Cycle Analysis

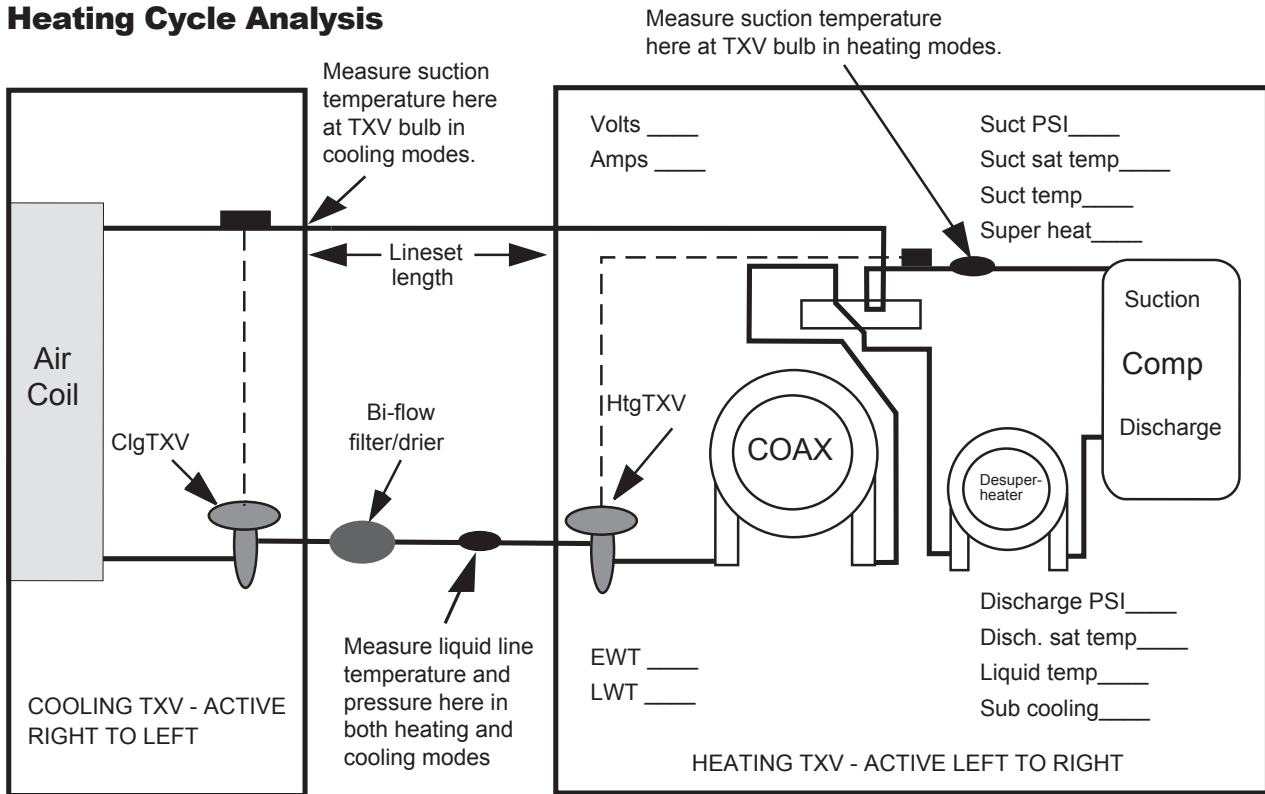

Heat of Extraction/Rejection = GPM x 500 (485 for water/antifreeze) x ΔT
Note: DO NOT hook up pressure gauges unless there appears to be a performance problem.

Cooling Cycle Analysis

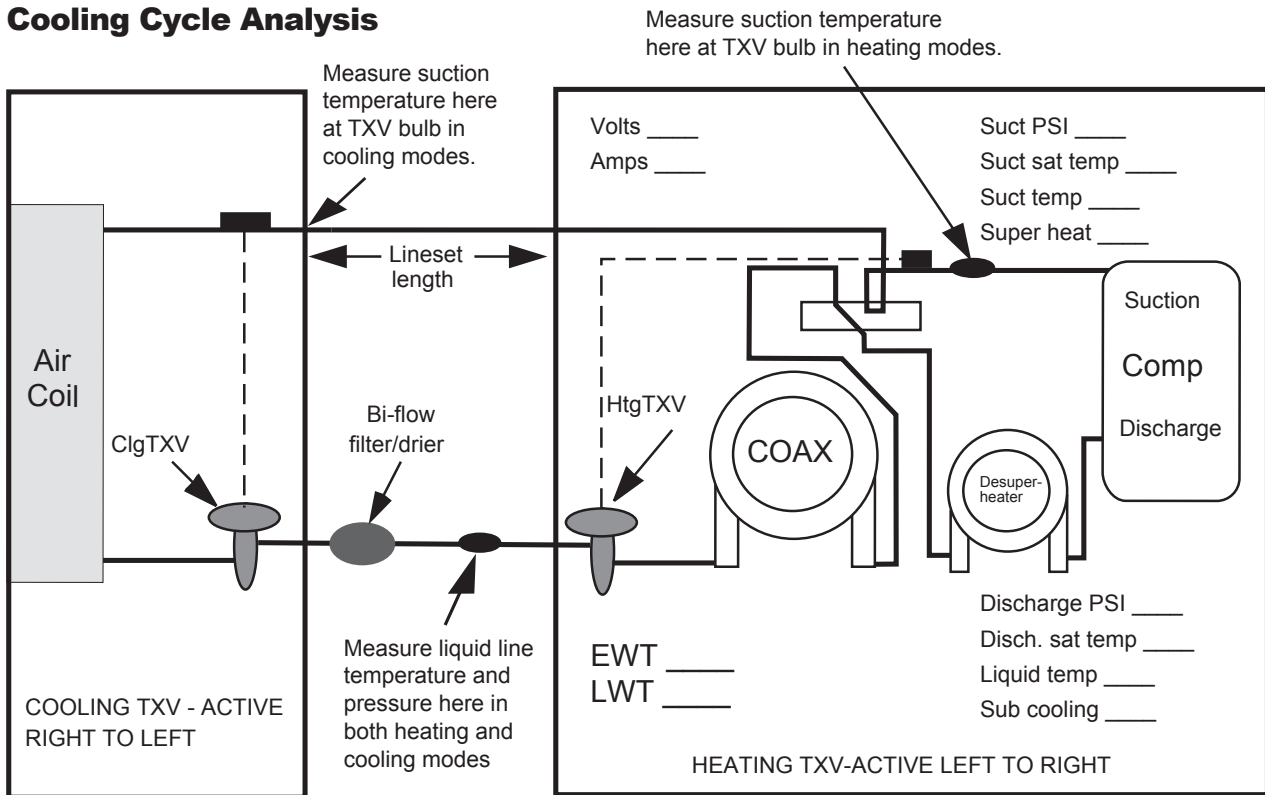

Troubleshooting

Standard Microprocessor Controls

To check the unit control board for proper operation:

1. Disconnect thermostat wires at the control board.
2. Jumper the desired test input (Y1, Y2, W, O or G) to the R terminal to simulate a thermostat signal.
3. If control functions properly:
 - Check for thermostat and field control wiring (use the diagnostic inputs mode).
4. If control responds improperly:
 - Ensure that component being controlled is functioning (compressor, blower, reversing valve, etc.).
 - Ensure that wiring from control to the component is functioning (refer to the LED Definition table below and use the diagnostic outputs mode).
 - If steps above check properly, replace unit control.

LED Definitions and Diagnostics

Standard Microprocessor

LED	NORMAL DISPLAY MODE		DIAGNOSTIC MODES							
			CURRENT FAULT STATUS		INPUTS		OUTPUTS 1		OUTPUTS 2	
	Field Selection DIPS									
	SW2-	1 On	SW2-	1 Off	SW2-	1 NA	SW2-	1 NA	SW2-	1 NA
	SW2-	6 On	SW2-	6 On	SW2-	6 Off	SW2-	6 On	SW2-	6 Off
	SW2-	7 On	SW2-	7 On	SW2-	7 On	SW2-	7 Off	SW2-	7 Off
Drain	Drain Pan Overflow Lockout		Drain Pan Overflow		Y1		Compressor (On or Low)		Blower Low	
Water Flow	FP Thermistor (Loop <15° F, Well<30°F) Lockout		FP Thermistor (Loop <15° F, Well<30°F)		Y2		Compressor (On or High)		Blower Medium	
High Pressure	High Pressure >600 PSI Lockout		High Pressure >600		O		Reversing Valve		Blower High	
Low Pressure, Current Sensor	Low Pressure <40		Low Pressure <40		G		Fan		Aux Heat 1	
Airflow	ECM2 RPM <100 RPM		ECM2 RPM <100 RPM		W		DHW Pump		Aux Heat 2	
Status	Microprocessor Malfunction		Not Used		SL1		Loop Pump 1		Aux Heat 3	
DHW Limit	HWL Thermistor >130°F		HWL Thermistor >130°F		Not Used		Loop Pump 2		Aux Heat 4	
DHW Off	DHW Pump Switch Off		DHW Pump Switch Off		-		-		-	

Refrigerant Systems

To maintain sealed circuit integrity, do not install service gauges unless unit operation appears abnormal. Compare the change in temperature on the air side as well as the water side to the tables on pages 26-27. If the unit's performance is not within the ranges listed, and the airflow and water flow are known to be correct, gauges should then be installed and superheat and subcooling numbers calculated. If superheat and subcooling are outside recommended ranges, an adjustment to the refrigerant charge may be necessary.

Notes: Refrigerant tests must be made with desuperheater turned "OFF". Verify that air and water flow rates are at proper levels before servicing the refrigerant circuit.

Preventive Maintenance

Water Coil Maintenance

1. Keep all air out of the water. An open loop system should be checked to ensure that the well head is not allowing air to infiltrate the water line. Lines should always be airtight.
2. Keep the system under pressure at all times. It is recommended in open loop systems that the water control valve be placed in the discharge line to prevent loss of pressure during off cycles. Closed loop systems must have positive static pressure.

Notes: On open loop systems, if the installation is in an area with a known high mineral content (125 PPM or greater) in the water, it is best to establish with the owner a periodic maintenance schedule so the coil can be checked regularly. Should periodic coil cleaning be necessary, use standard coil cleaning procedures which are compatible with either the cupronickel or copper water lines. Generally, the more water flowing through the unit the less chance for scaling.

Other Maintenance

Filters

Filters must be clean to obtain maximum performance. They should be inspected monthly under normal operating conditions and be replaced when necessary. Units should never be operated without a filter.

Condensate Drain

In areas where airborne bacteria produce a slime in the drain pan, it may be necessary to treat chemically to minimize the problem. The condensate drain can pick up lint and dirt, especially with dirty filters. Inspect twice a year to avoid the possibility of overflow.

Blower Motors

Blower motors on most air handlers are equipped with sealed ball bearings and require no periodic oiling.

Desuperheater Coil

See Water Coil Maintenance section above.

Air Coil

The air coil must be cleaned to obtain maximum performance. Check once a year under normal operating conditions and, if dirty, brush or vacuum clean. Care must be taken not to damage the aluminum fins while cleaning.



CAUTION: Fin edges are sharp.

Replacement Procedures

Obtaining Parts

When ordering service or replacement parts, refer to the model number and serial number of the unit as stamped on the serial plate attached to the unit. If replacement parts are required, mention the date of installation of the unit and the date of failure, along with an explanation of the malfunctions and a description of the replacement parts required.

In-Warranty Material Return

Material may not be returned except by permission of authorized warranty personnel. Contact your local distributor for warranty return authorization and assistance.

Physical Dimensions

Cabinet Dimensions and Refrigerant Piping Connections

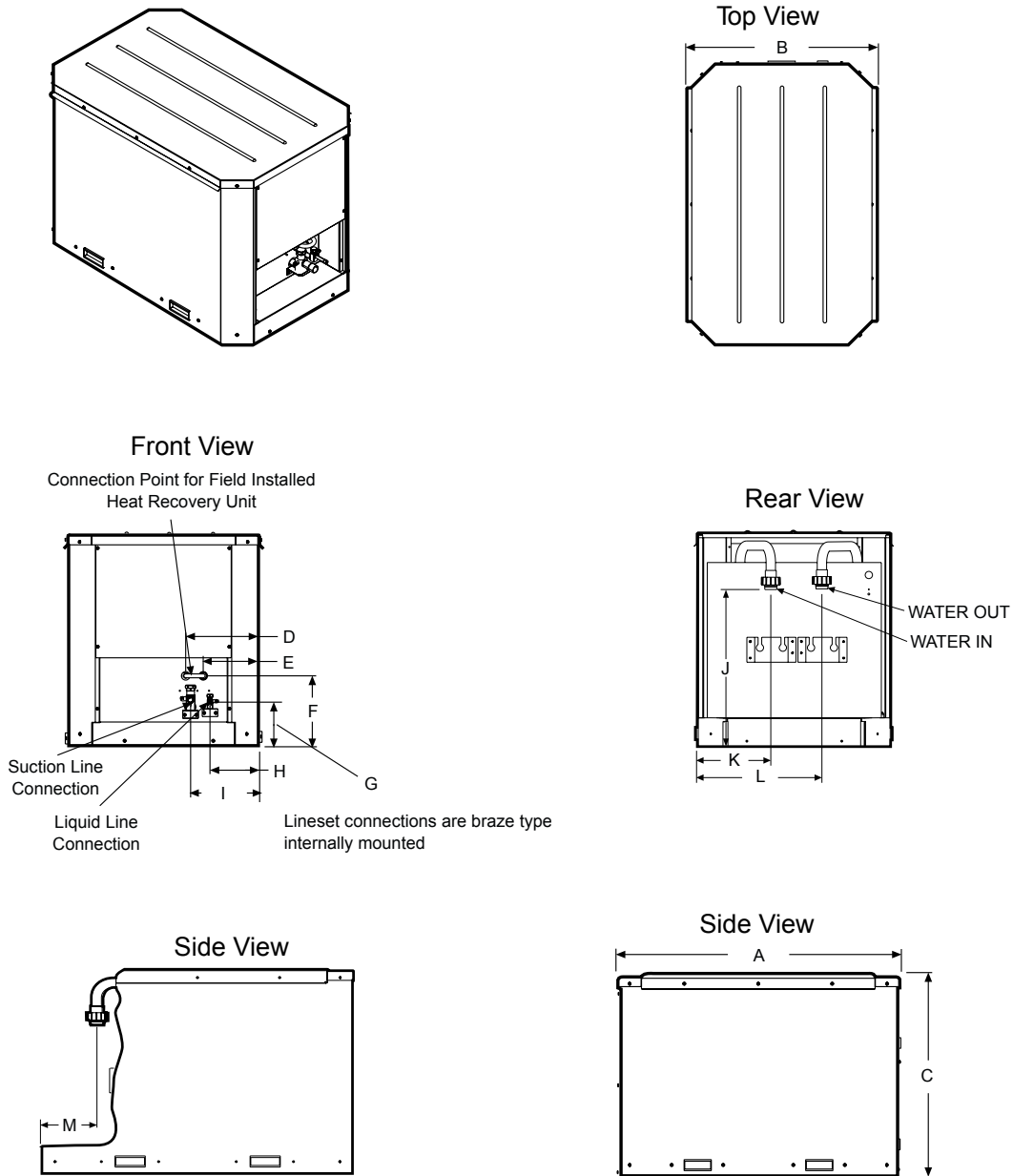

PHYSICAL DIMENSIONS													
MODEL	A	B	C	D	E	F	G	H	I	J	K	L	M
NS026 thru NS072	36.0	23.9	25.7	9.3	7.1	9.0	5.6	8.2	10.7	18.9	8.7	14.8	7.0
	[91.4]	[60.7]	[65.2]	[23.7]	[18.0]	[22.8]	[14.2]	[20.9]	[27.2]	[48.0]	[22.1]	[37.6]	[17.8]

Notes: Refer to Physical Dimensions and Piping Connections drawings
Inches [cm]

Installation Notes:



Manufactured by
WaterFurnace International, Inc.
9000 Conservation Way
Fort Wayne, IN 46809
www.waterfurnace.com

Product: **Envision Series - NS Outdoor Split**
Type: Geothermal/Water Source Heat Pumps
Size: 2-6 Tons
Document: Installation Manual



WaterFurnace Renewable Energy has a policy of continuous product research and development and reserves the right to change design and specifications without notice. ©2008 WRE.