

WWW.McCULLOCH.COM

Original instructions

Husqvarna AB
SE-561 82 Huskvarna
Sweden

576191711

Rev. 5 2013-1-17

GB Operator's manual

WARNING: For your own safety please read this manual before attempting to operate your new unit. Failure to follow instructions can result in serious personal injury. Spend a few moments to familiarize yourself with your trimmer before each use.

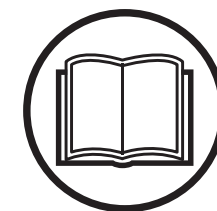

MT 260 CLS



Meaning of symbols marked on the product

| | | | |
|--|---|--|--|
| | Read the user manual before using the machine | | Warning! Hot surface |
| | Whenever the machine is in use, safety glasses must be worn to safeguard against flying objects. Hearing protection must also be used in order to protect to operators hearing. | | Keep people or animals at least 15m away from the machine during operation |
| | Wear gloves to protect your hands | | Warning! Cutting elements continue to rotate after the engine turned off. |
| | Wear foot protection | | Beware of thrown objects |
| | Do not use metal blades | | Guaranteed sound power level LWA accordance with directive 2000/14/EC + 2005/88/EC |
| | Maximum rotational frequency of the spindle for cutting head | | Sound pressure level at 7,5 metres. |

WARNING! When using petrol tools, basic safety precautions, including the following, should always be followed to reduce the risk of serious personal injury and/or damage to the unit.

Read all these instructions before operating this product and save these instructions.

WARNING! This machine produces an electromagnetic field during operation. This field may under some circumstances interfere with active or passive medical implants. To reduce the risk of serious or fatal injury, we recommend persons with medical implants to consult their physician and the medical implant manufacturer before operating this machine.

WHAT TO DO

This power unit can be dangerous! Operator is responsible for following unit manual instructions and warnings. Read entire operator's manual before using unit! Be thoroughly familiar with the controls and the proper use of the unit. Restrict the use of this unit to persons who read, understand, and follow unit, manual instructions and warnings. Never allow children to operate this unit.

DANGER: Never use blades, wire or flailing devices. Unit is designed for line trimmer use only. Use of any other accessories or attachments will increase the risk of injury.



WARNING: Keep children, bystanders, and animals 50 feet (15 metres) away. If approached stop unit immediately.

1. **Wear close fitting, tough work clothing** that will provide protection, such as long slacks or trousers, safety work shoes, heavy duty work gloves, hard hat, a safety face shield, or safety glasses for eye protection and a good grade of ear plugs or other sound barriers for hearing protection.
2. **Store in a safe place.** Open fuel cap slowly to release any pressure which may have formed in fuel tank. To prevent a fire hazard, move at least 10 feet (3 metres) from fueling area before starting.
3. **Turn unit off** before setting it down.
4. **Always hold unit firmly with both hands,** the thumb and fingers encircling the handles.

5. **Keep all screws and fasteners tight.** Never operate your equipment when it is improperly adjusted or not completely and securely assembled.
6. **Keep handles dry,** clean and free of fuel mixture.
7. **Keep stringhead as close to ground as practical.** Avoid hitting small objects with trimmer head. When cutting on a slope, stand below trimmer head. NEVER cut or trim on a hill or slope, etc. If there is the slightest chance of slipping, sliding or losing firm footing.
8. **Check area you will be trimming for debris** that may be struck or thrown during operation.
9. **Keep all parts of your body and clothing away from trimmer head** when starting or running engine. Before starting engine, make sure trimmer head will not come in contact with any obstacle.
10. **Stop engine** before examining cutting line.
11. **Store equipment away from possible flammable materials,** such as gas-powered water heaters, clothes dryers, or oil-fired furnaces, portable heaters, etc.
12. **Always keep** the debris shield, trimmer head, and engine free of debris build-up.
13. **Operation of equipment** should always be restricted to mature and properly instructed individuals.
14. **WARNING:** The emission of exhaust gases is toxic.
15. **Emergency Stopping Procedure.** When it is necessary to stop engine immediately, DEPRESS the switch to stop.
16. This unit has a clutch. The routine for checking that the clutch is working correctly is that when the engine returns to idle the trimmer head stops spinning.
17. Tighten the cap of oil and fuel tank to prevent the loss of oil and fuel during transport

18. It is recommended that daily inspection before use and after dropping or other impacts to prevent significant damage or defects.

19. Prolonged use of this product expose the operator to vibrations and may produce 'whitefinger' disease. In order to reduce the risk, please wear gloves and keep your hands warm. If any of the 'whitefinger' symptoms appear, seek medical advice immediately.

WHAT NOT TO DO

1. **DO NOT USE ANY OTHER FUEL** than that recommended in your manual. Always follow instructions in the Fuel and Lubrication section of this manual. Never use gasoline unless it is properly mixed with 2-cycle engine lubricant. Permanent damage to engine will result, voiding manufacturer's warranty.
2. **DO NOT SMOKE** while refueling or operating equipment.
3. **DO NOT OPERATE UNIT WITHOUT A MUFFLER** and properly installed muffler shield.
4. **DO NOT TOUCH** or let your hands or body come in contact with a hot muffler or spark plug wire.
5. **DO NOT OPERATE UNIT IN AWKWARD POSITIONS,** off balance, outstretched arms, or one-handed. Always use two hands when operating unit with thumbs and fingers encircling the handles.
6. **DO NOT RAISE TRIMMER HEAD** above ground level while unit is operating. Injury to operator could result.
7. **DO NOT USE UNIT FOR ANY PURPOSES OTHER** than trimming lawn or garden areas.
8. **DO NOT OPERATE UNIT FOR PROLONGED PERIODS.** Rest periodically.
9. **DO NOT OPERATE UNIT WHILE UNDER THE INFLUENCE OF ALCOHOL OR DRUGS.**
10. **DO NOT OPERATE UNIT UNLESS DEBRIS SHIELD AND/OR GUARD IS INSTALLED AND IN GOOD CONDITION.**
11. **DO NOT ADD, REMOVE OR ALTER ANY COMPONENTS OF THIS PRODUCT.** Doing so could cause personal injury and/or damage the unit voiding the manufacturer's warranty.
12. **DO NOT operate** your unit near or around flammable liquids or gases whether in or out of doors. An explosion and/or fire may result.
13. **DO NOT USE ANY OTHER CUTTING ATTACHMENT.** Use only Mcculloch replacement parts and accessories, which are designed specifically to enhance the performance and maximize the safe operation of our products. Failure to do so may cause poor performance and possible injury. Use only the stringhead supplied with this product. *Do not use any other cutting attachment.* Use of such attachments will void your factory warranty and could result in serious bodily injury.

SPECIFICATIONS

| | |
|---|--------------------------------------|
| Model No. | MT 260 CLS |
| Engine Type | Air-cooled, 2-Cycle, Chrome Cylinder |
| Displacement | 26cm ³ |
| Dry Weight | 5.00 kg |
| Fuel Capacity | 550 cm ³ |
| Bump Head | Twin Line Bump Feed |
| Drive Shaft Length | 66+66 cm |
| Cutting Width | 43cm |
| Handle | "D" Handle |
| Ignition | Electronic |
| Drive | Centrifugal Clutch |
| Sound levels (see note 1) | |
| Equivalent sound pressure level at the operators ear..... | 98.37 dB(A) |
| Noise emissions (see note 2) | |
| Measured sound power level..... | 107.31 dB(A) |
| Guaranteed sound power level..... | 110 dB(A) |
| Vibration (K=1.5) | 6.796 m/s ² |
| Maximum Engine Performance | 0.78 kw |
| Engine Speed (rotationa lfrequency) at recommended | |
| max. spindle rotational frequency | 7800 min ⁻¹ |
| Maximum rotational frequency of the spindle (Max.) | 7800 min ⁻¹ |
| Idle speed | 3000±300 min ⁻¹ |
| Specific fuel consumption | 415.3 g/kWh |

Note 1: Equivalent sound pressure level, according to ISO 22868, is calculated as the time-weighted energy total for different sound pressure levels under various working conditions. Typical statistical dispersion for equivalent sound pressure level is a standard deviation of 1.5 dB (A).

Note 2: Noise emissions in the environment measured as sound power (Lwa) in conformity with EC directive 2000/14/EC.

GENERAL IDENTIFICATION

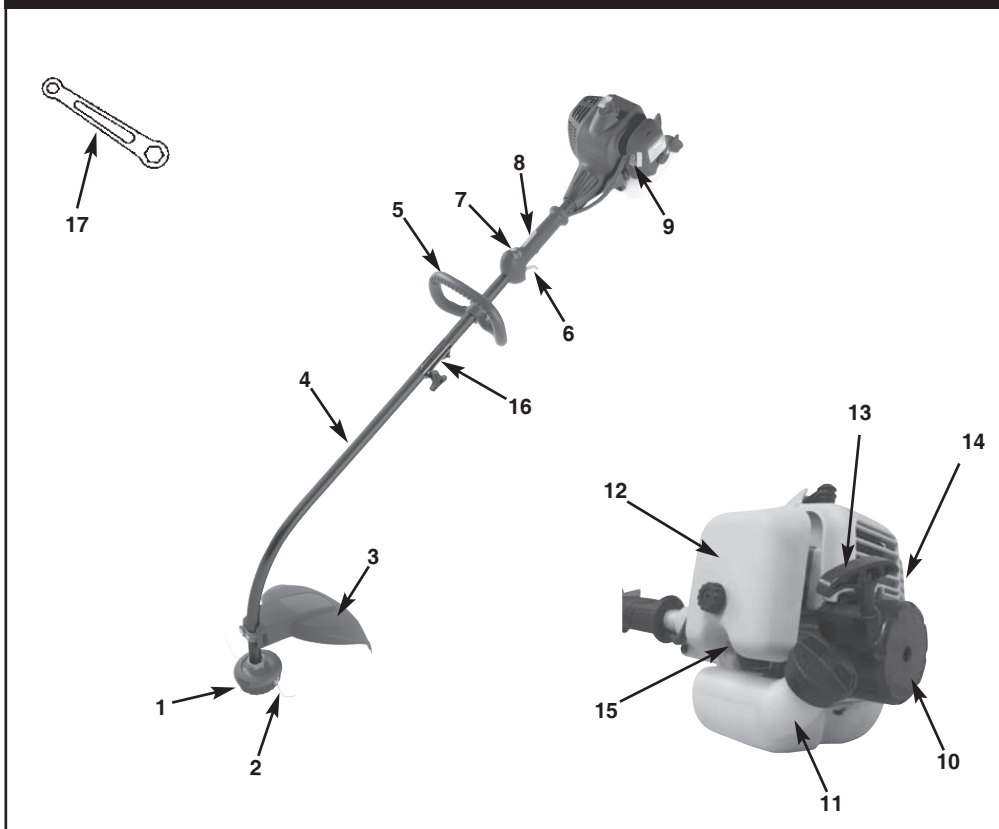

- | | | |
|-----------------------------|--------------------------|-------------|
| 1. TRIMMER HEAD | 9. CHOKE LEVER | 16. COUPLER |
| 2. TRIMMER LINE | 10. STARTER ROPE HOUSING | 17. SPANNER |
| 3. SHIELD | 11. FUEL TANK | |
| 4. DRIVE SHAFT | 12. AIR FILTER COVER | |
| 5. "D" HANDLE | 13. STARTER HANDLE | |
| 6. THROTTLE TRIGGER | 14. MUFFLER SHIELD | |
| 7. ON/OFF SWITCH | 15. PRIMER BULB | |
| 8. THROTTLE TRIGGER LOCKOUT | | |
- *Supplied in User Kit
- NOTE:** DO NOT use blades on this model.

SAFETY FEATURES

Numbers preceding the descriptions correspond with numbers on preceding page to help you locate the safety feature.

- 3 DEBRIS SHIELD must be installed to prevent debris from being thrown at the operator and prevent the trimmer line from extending longer than necessary.
- 14 MUFFLER SHIELD helps prevent hands, body and/or combustible materials from making contact with a hot muffler.

ASSEMBLY INSTRUCTIONS



WARNING: Please assemble the unit according to the assembly instructions. Failure to do so may cause injury to the operator

• "D" HANDLE INSTALLATION



WARNING: When adjusting the assist handle, be sure it remains above the safety label.

1. Position "D" handle on the shaft. Note that the handle must be mounted in front of direction of arrow head on the shaft. (The distance between both handles shall be at least 250mm.)

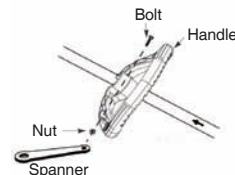

2. Install the bolt and nut as shown in the illustration.

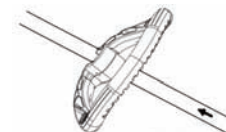

3. Make a final adjustment of the handle to a comfortable working position. Tighten the nut firmly with wrench (provided).

• ATTACHING THE SHIELD



WARNING: The shield must be properly installed. The shield provides partial protection from the risk of thrown objects to the operator and others and is equipped with a line limiter which cuts excess line. The line limiter (on underside of shield) is sharp and can cut you.

1. Remove nut from shield.
2. Insert bracket into slot on shield (Fig. 1).
3. Pivot shield until bolt passes through hole in bracket.
4. Reinstall nut and tighten securely with wrench (provided)(Fig. 2).

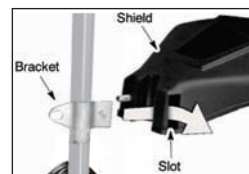

Fig. 1



Fig. 2

• INSTALLING THE ATTACHMENT



WARNING: To avoid serious personal injury, turn unit off before removing or installing attachment.

NOTE: To make installing or removing the attachment easier, place the unit on the ground or on a work bench.

1. Turn the knob (A) counter clockwise to loosen (Fig. 3A).
2. While firmly holding the attachment (B), push it straight into the Quick-Change coupler (C) until the release button (D) appears in the primary hole (E) of the Quick-Change coupler. (Fig. 3B)
3. Turn the knob (A) clockwise to tighten. (Fig. 3C)



CAUTION: The release button must be in the primary hole and the knob must be tightened securely before operating this unit.

All attachments are designed to be used in the primary hole unless otherwise indicated in the specific attachments operators manual. If the incorrect hole is used, it could result in injury, or damage to the unit.

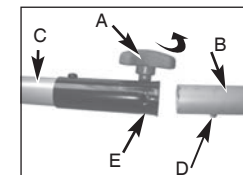

Fig. 3A

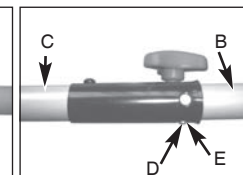

Fig. 3B

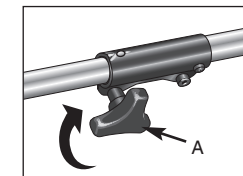

Fig. 3C

FUEL AND LUBRICATION

• FUEL

Use regular grade unleaded gasoline mixed with McCulloch 40:1 custom 2-cycle engine oil for best results. Use mixing ratios in **Fuel Mixing Table**.



WARNING: Never use straight gasoline in your unit. This will cause permanent engine damage and void the manufacturer's warranty for that product. Never use a fuel mixture that has been stored for over 90 days.



WARNING: If 2-cycle lubricant other than McCulloch Custom Lubricant is to be used, it must be a premium grade oil for 2-cycle air cooled engines mixed at a 40:1 ratio. Do not use any 2-cycle oil product with a recommended mixing ratio of 100:1. If insufficient lubrication is the cause of engine damage, it voids the manufacturer's engine warranty.

MIXING FUEL

Add oil to an approved fuel container followed by the gasoline to allow incoming gasoline to mix with oil. Shake container to ensure thorough mix.

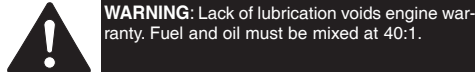

FUEL AND LUBRICATION

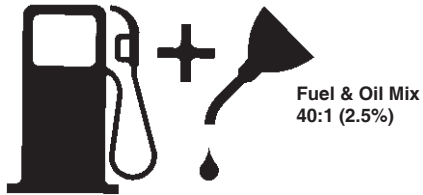

FUEL / OIL MIXTURE RATIOS

| Petrol - Litre | Two-Stroke Oil - ml |
|----------------|---------------------|
| | 40:1 (2.5%) |
| 2 | 50 |
| 5 | 125 |
| 10 | 250 |

RECOMMENDED FUELS

Some conventional gasolines are being blended with oxygenates such as alcohol or an ether compound to meet clean air standards. Your McCulloch engine is designed to operate satisfactorily on any fuel intended for automotive use including oxygenated fuels.

OPERATING INSTRUCTIONS

STARTING A COLD ENGINE

NOTE: To minimize load on engine during starting and warm-up, trim excess line to 13cm (Fig. 4A).

1. Press ON/OFF Switch to the "RUN(I)" position (Fig. 4B)
2. Your unit is designed with a 3 position choke: FULL CHOKE "N", HALF CHOKE ":", and RUN "||". Move choke lever to FULL CHOKE "N" position, while the throttle trigger is in full position (Fig. 4C).
3. Press the primer bulb (A) 10 times (Fig. 4D).
4. Wait 10 sec.
5. A smooth rapid pull is required for a strong spark. Pull starter rope briskly maximum 6 times. (Fig. 4F) As soon as the engine sounds as if it is trying to start (even if less than 6 pulls) then move the choke lever to HALF CHOKE ":" position.(Fig. 4G)
6. Pull starter rope again 4 times while trigger is in the full throttle position (Fig. 4F).
7. Once engine is started, leave the choke lever in the HALF CHOKE ":" position for 20 seconds, then move choke lever to RUN "||". (Fig. 4H)
If engine does not start, go back to step 2.

NOTE: If engine fails to start after repeated attempts, refer to Troubleshooting section.

NOTE: Always pull starter rope straight out. Pulling starter at an angle will cause rope to rub against the eyelet. This friction will cause the rope to fray and wear more quickly. Always hold starter handle when rope retracts. Never allow rope to snap back from extended position. This could cause rope to snag or fray and also damage the starter assembly.

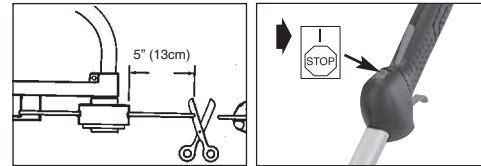

Fig. 4A

Fig. 4B

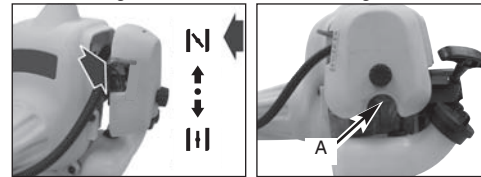

Fig. 4C

Fig. 4D

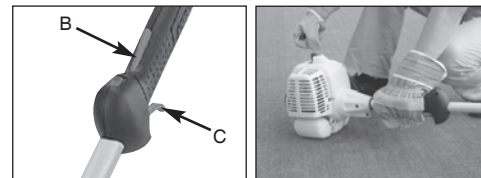

Fig. 4E

Fig. 4F

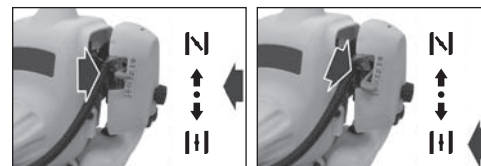

Fig. 4G

Fig. 4H

WARM ENGINE START

1. Move engine stopping device to the "RUN" position (Fig. 5A).
2. Place choke in HALF CHOKE ":" position (Fig. 5B).
3. Grasp throttle handle firmly, squeeze throttle trigger to FULL position.
4. Pull starter rope briskly until engine starts, but no more than 6 times. Keep throttle at FULL position until engine runs smoothly.

5. If engine does not start, place choke in RUN "||" position and pull starter rope 5 more times. If engine still does not start it is probably flooded. Wait 5 minutes and repeat procedure with choke in RUN "||" position and throttle full open.

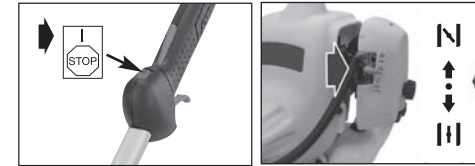

Fig. 5A

Fig. 5B

TO STOP ENGINE

Release throttle trigger. Let engine return to idle. Push the ignition stop switch to stop the engine.

OPERATING INSTRUCTIONS

OPERATING POSITION

ALWAYS WEAR:

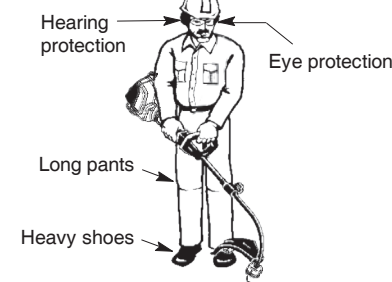

Cut from your right to your left.

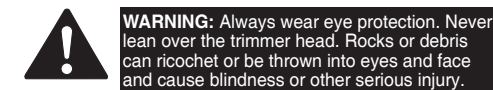

Do not run the engine at a higher speed than necessary. The cutting line will cut efficiently when the engine is run at less than full throttle. At lower speeds, there is less engine noise and vibration. The cutting line will last longer and will be less likely to "weld" onto the spool. Always release the throttle trigger and allow the engine to return to idle speed when not cutting.

- To stop engine:
- Release the throttle trigger.
 - Push and release the engine ON/STOP switch.

TRIMMER LINE ADVANCE

The trimmer line will advance approximately 2 inches (5 cm) each time the bottom of the trimmer head is tapped on the ground with the engine running at full throttle. The most efficient line length is the maximum length allowed by the line limiter.

Always keep the shield in place when the tool is being operated.

To advance line:

- Operate the engine at full throttle.
- Hold the trimmer head parallel to and above the grassy area.
- Tap the bottom of the trimmer head lightly on the ground one time. Approximately 2 inches (5 cm) of line will be advanced with each tap.

Always tap the trimmer head on a grassy area. Tapping on surfaces such as concrete or asphalt can cause excessive wear to the trimmer head.

If the line is worn down to 2 inches (5 cm) or less, more than one tap will be required to obtain the most efficient line length.

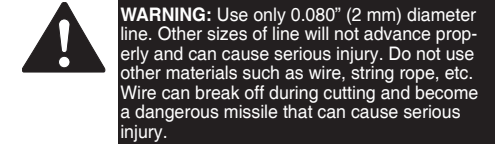

CUTTING METHODS

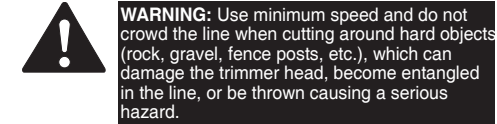

- The tip of the line does the cutting. You will achieve the best performance and minimum line wear by not crowding the line into the cutting area. The right and wrong ways are shown below.

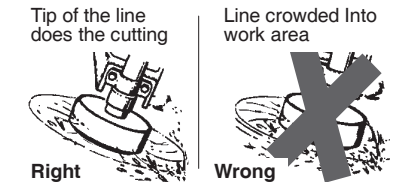

- The line will easily remove grass and weeds from around walls, fences, trees and flower beds, but it also can cut the tender bark of trees or shrubs and scar fences.
- For trimming or scalping, use less than full throttle to increase line life and decrease head wear, especially:
 - During light duty cutting.
 - Near objects around which the line can wrap such as small posts, trees or fence wire.
- For mowing or sweeping, use full throttle for a good clean job.

TRIMMING - Hold the bottom of the trimmer head about 3 inches (8 cm) above the ground and at an angle. Allow only the top of the line to make contact. Do not force trimmer line into work area.

Trimming

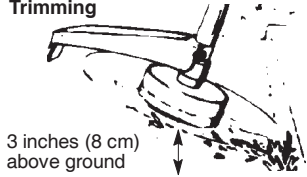

SCALPING - The scalping technique removes unwanted vegetation down to the ground. Hold the bottom of the trimmer head about 3 inches (8 cm) above the ground and at an angle. Allow the top of the line to strike the ground around trees, posts, monuments, etc. This technique increases line wear.

Scalping

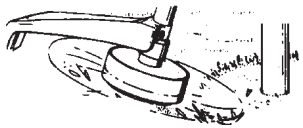

MOWING - Your trimmer is ideal for mowing in places conventional lawn mowers cannot reach. In the mowing position, keep the line parallel to the ground. Avoid pressing the head into the ground as this can scalp the ground and damage the tool.

Mowing

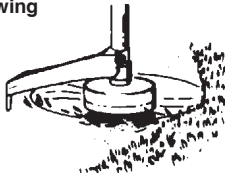

SWEEPING - The fanning action of the rotating line can be used for a quick and easy clean up. Keep the line parallel to and above the surfaces being swept and move the tool from side to side.

Sweeping

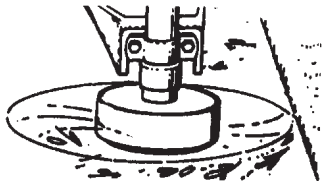

MAINTENANCE



WARNING: Disconnect the spark plug before performing maintenance except for carburetor adjustments.



HELPFUL TIP
IMPORTANT: Have all repairs other than the recommended maintenance described in the instruction manual performed by an authorized service dealer.

If any dealer other than an authorized service dealer performs work on the product, McCULLOCH may not pay for repairs under warranty. It is your responsibility to maintain and perform general maintenance.

CHECK FOR LOOSE FASTENERS AND PARTS

- Spark Plug Boot
- Air Filter
- Housing Screws
- Assist Handle Screw
- Debris shield

CHECK FOR DAMAGED OR WORN PARTS

- Contact an authorized service dealer for replacement of damaged or worn parts.
- ON/STOP Switch - Ensure ON/STOP switch functions properly by pushing the switch. Make sure engine stops. Wait 5 seconds before attempting to restart unit to allow switch to reset. Restart engine and continue.
 - Fuel Tank - Discontinue use of unit if fuel tank shows signs of damage or leaks.
 - Debris Shield - Discontinue use of unit if debris shield is damaged.

AIR FILTER



CAUTION: NEVER operate trimmer without the air filter. The air filter must be kept clean. If it becomes damaged, install a new filter

To Clean Air Filter:

1. Remove knob (A) holding air filter cover in place, remove cover (B) and lift filter (C) from air box (Fig. 7)
2. Wash filter in soap and water. **DO NOT USE PETROL!**
3. Air dry filter.
4. Reinstall filter.

NOTE: Replace filter if frayed, torn, damaged or unable to be cleaned.

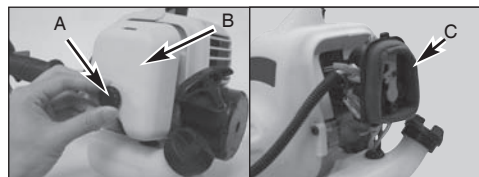

Fig. 7

FUEL CAP / FUEL FILTER



CAUTION: Remove fuel from unit and store in approved container before starting this procedure. Open fuel cap slowly to release any pressure which may have formed in fuel tank.

1. Completely remove fuel cap (A) from fuel tank (B) to be able to remove fuel filter (D) from tank. Use a piece of wire (C) with a hook formed at the end to pull filter out of tank. (Fig. 8A & Fig. 8B)
2. Pull filter (D) off with a twisting motion.
3. Replace fuel filter (D). (Fig. 8C)

NOTE: Never operate the trimmer without the fuel filter. Internal engine damage could result!

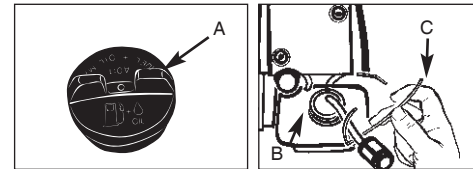

Fig. 8A

Fig. 8B

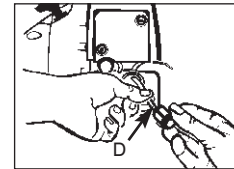

Fig. 8C

CARBURETOR ADJUSTMENT

The carburetor was pre-set at the factory for optimum performance. If further adjustments are necessary, please take your unit to the nearest professional Service Center.

SPARK PLUG

1. Spark plug gap = .025" (.635mm) (Fig. 9).
2. Torque to 105 to 130 inch pounds (12 to 15 N•m). Connect spark plug boot.

DEBRIS SHIELD KNIFE SHARPENING

1. Remove cutter knife (E) from debris shield (F) (Fig. 10).
2. Place knife in a bench vise. Sharpen knife using a flat file, being careful to maintain the angle of cutting edge. File in one direction only.

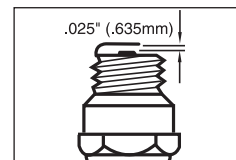

Fig. 9

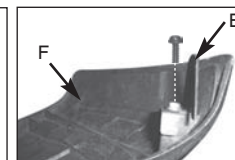

Fig. 10

STORING A UNIT



WARNING: Failure to follow these steps may cause varnish to form in the carburetor and difficult starting or permanent damage following storage.

1. Perform all the general maintenance recommended in the Maintenance Section of your User Manual.
2. Clean exterior of engine, Output Shaft, cutting attachment guard and cutting head.
3. Drain fuel from the fuel tank.
4. After fuel is drained, start engine.
5. Run engine at idle until unit stops. This will purge the carburetor of fuel.
6. Allow engine to cool (approx. 5 minutes).
7. Using a spark plug wrench, remove the spark plug.
8. Pour 1 teaspoon of clean 2-cycle oil into the combustion chamber. Pull starter rope slowly several times to coat internal components. Replace spark plug.
9. Store unit in a cool, dry place away from any source of ignition such as an oil burner, water heater, etc.

REMOVING A UNIT FROM STORAGE

1. Remove spark plug.
2. Pull starter rope briskly to clear excess oil from combustion chamber.
3. Clean and gap spark plug or install a new spark plug with proper gap.
4. Prepare unit for operation.
5. Fill fuel tank with new, fresh fuel / oil mixture See Fuel and Lubrication Section.

SERVICE AND ADJUSTMENTS

REPLACING THE LINE

1. Press the tabs on the side of the trimmer head and remove cover and spool.

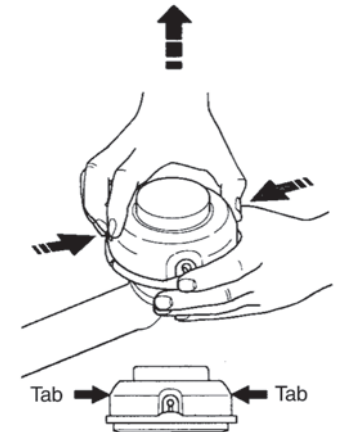

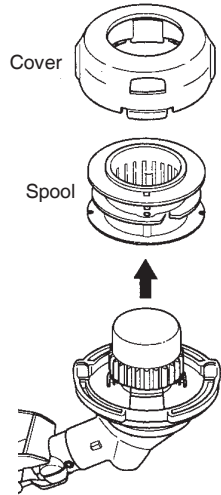

2. Remove any remaining line.
3. Clean dirt and debris from all parts. Replace spool if it is worn or damaged.
4. Replace with a pre-wound spool, or replace line using a 25 feet (8 metres) length of 0.080 inch (2 mm) diameter McCULLOCH brand line.



WARNING: Never use wire, rope, string, etc., which can break off and become a dangerous missile.

5. When installing new line on an existing spool, hold the spool as shown.
6. Bend the line at the midpoint and inset the bend into the slot in the center rim of the spool. Ensure line snaps into position in the slot.

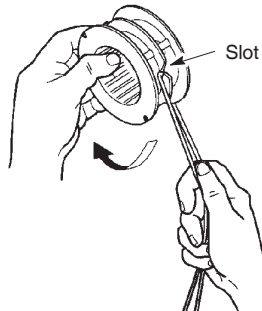

7. With your finger between the lines, wrap the lines evenly and firmly around the spool in a clockwise direction.

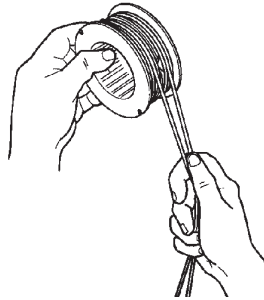

8. Position the lines in the guide slots.

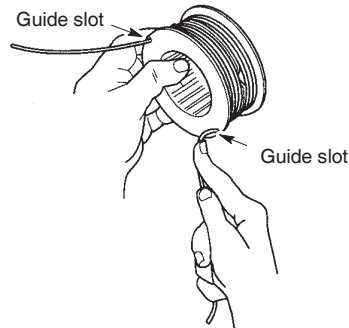

9. Place the spool in the cover as shown below.

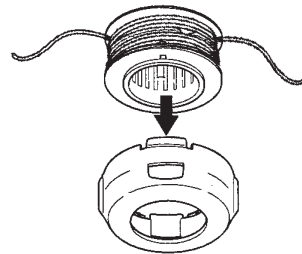

10. Insert the ends of the lines through exit holes in the sides of the cover.

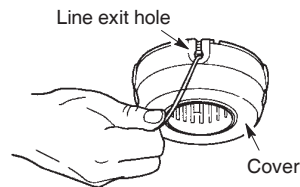

11. Reinstall the spool and cover onto the trimmer head. Push until cover snaps into place.

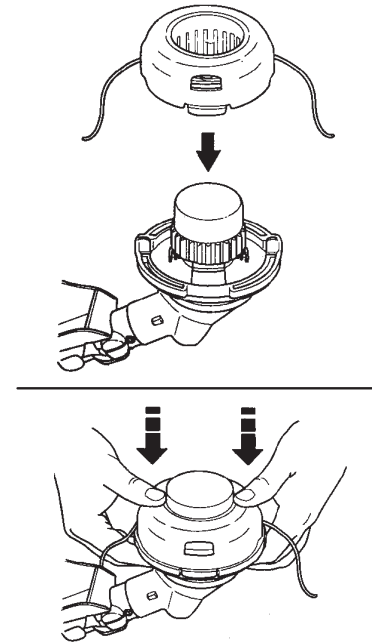

REPLACING THE TRIMMER HEAD

1. Hold the dust cup with a wrench to keep the shaft from turning while removing and installing trimmer head.

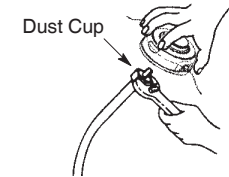

2. Remove trimmer head by turning counterclockwise (looking from bottom of unit).
3. Thread replacement trimmer head onto the shaft by turning clockwise. **Only tighten hand tight!**

TROUBLE SHOOTING THE ENGINE

| PROBLEM | PROBABLE CAUSE | CORRECTIVE ACTION |
|--|--|---|
| Unit won't start or starts but will not run. | Incorrect starting procedures. | Follow instructions in the User Manual. |
| | Incorrect carburetor mixture adjustment setting. | Have carburetor adjusted by an Authorized Service Center. |
| | Fouled spark plug | Clean / gap or replace plug. |
| | Fuel filter blocked. | Replace fuel filter. |
| Unit starts, but engine has low power. | Incorrect lever position on choke. | Move to RUN position. |
| | Dirty spark arrester screen. | Replace spark arrester screen. |
| | Dirty air filter. | Remove, clean and reinstall filter. |
| Engine hesitates. | Incorrect carburetor mixture adjustment setting. | Have carburetor adjusted by an Authorized Service Center. |
| | No power under load. | Have carburetor adjusted by an Authorized Service Center. |
| Runs erratically. | Incorrectly gapped spark plug. | Clean / gap or replace plug. |
| Smokes excessively. | Incorrect carburetor mixture adjustment setting. | Have carburetor adjusted by an Authorized Service Center. |
| | Incorrect fuel mixture. | Use properly mixed fuel (40:1 mixture). |



EC DECLARATION OF CONFORMITY

Business name of the manufacturer: Husqvarna AB

Full address of the manufacturer: SE-561 82 Huskvarna, Sweden

We declare that the machinery

Product name: Petrol Grass trimmer

Commercial name: Petrol trimmer

Function: Trimming grass

Model: MT 260 CLS

Type: Powered by petrol

Fulfils all the relevant provisions of Directives

2006/42/EC, 2004/108/EC, 2000/14/EC+2005/88/EC,
97/68/EC+2004/26/EC

and tested in accordance with below standards

EN ISO 11806:2011

EN ISO 14982:2009

The conformity assessment of Directive 2000/14/EC, was done using Annex V of the Directive. For information regarding noise emissions and rated net power, see Technical Data Sheet.

Person authorised to compile the technical file and .
make this declaration:

Name, surname : Bo R Jonsson

Position/Title : R&D Manager

Address : SE-561 82 Huskvarna, Sweden

Place and date of the declaration: Shanghai, PRC 2013/1/18