

enovate
MEDICAL



slimline

IM022-01

MANUAL 09.15.15

The Enovate Medical Slimline Cart was designed to set a new standard in quality. Enovate Medical's goal is to provide a cart that is built right, ready for years of use, and backed by a commitment of exemplary service and support.

Thank you for purchasing the
Enovate Medical Slimline Cart



Distributed by:
Enovate Medical
US Headquarters
1152 Park Avenue
Murfreesboro, TN 37129
Support t@enovatemedical.com
Toll free 888.909.8930

For laptop compatibility please check with your local
Enovate Medical Representative or call us toll-free (888) 909-8930

1	WELCOME
3	WARNINGS
8	EMI
9	OVERVIEW
10	UNPACKING
12	CART FEATURES
14	POWER SYSTEM
18	POWER SPECIFICATIONS
20	SYSTEM ELECTROMAGNETIC EMISSIONS











Congratulations on your purchase of the Enovate Medical cart. Please do not use your medical cart until you have read this manual in its entirety as it contains important safety and use information. The Enovate Medical cart should only be used as outlined in this manual. Be sure to keep the manual in a safe place for future reference. If at any time you have questions or concerns about the contents of this manual or the use of your Enovate Medical cart, please contact Enovate Medical Customer Service toll free at 888.909.8930

This manual and the accompanying product labels and safety labeling materials of the Enovate Medical cart frequently employ the use of symbols with or without accompanying text. Health products regulatory agencies require the use of symbols, often in place of textual statements, to enhance the legibility of labeling and thus improve the conspicuousness of required information such as important safety information. Your attention to the presence and content of symbols used in this manual will help to ensure the safe use of your Enovate Medical cart. The following chart depicts the symbols used and provides a definition for each symbol found in this manual and in the labels and labeling materials of the Enovate Medical cart.

Distributed by:
Enovate Medical
US Headquarters
1152 Park Avenue
Murfreesboro, TN 37129
Support@enovatemedical.com
Toll free 888.909.8930

The term “symbols” refers to the use of graphical symbols without equivalent accompanying text. Symbols are used by medical device manufacturers to create uniform labels and labeling for the United States, European Union, and any other countries that may permit their use in medical products. By using symbols in place of some textual statements, manufacturers may enhance the legibility of labeling and thus improve the conspicuousness of required information; especially where information is contained upon product labels that are restricted in their space available.











The use of symbols on the product labels are intended to conform to international consensus standards. The following chart depicts the symbols used and provides a definition for each symbol found in the labels.

	CAUTION, CONSULT ACCOMPANYING DOCUMENTS
	CONSULT INSTRUCTIONS FOR USE
	ELECTRIC SHOCK WARNING SYMBOL
	MANUFACTURER
	SERIAL NUMBER
	CATALOG NUMBER
	TYPE B APPLIED PART
	AUTHORIZED REPRESENTATIVE IN THE EUROPEAN COMMUNITY
	The CE mark on this product indicates it has been tested to and conforms with the provisions noted within the 93/42/EEC Medical Device Directive
	Accredited testing laboratory has evaluated a sample of the product and determined that it complies with applicable national standards, <enter , as applicable, Canadian and US>.

Warnings



The above symbols represent safety warnings that require significant attention when seen on the EMC cart or in the user manual. Failure to do so could result in minor injury, major injury, or even death.

-  Do not use in the presence of an anesthetic mixture with air or with oxygen or nitrous oxide.
-  **USE A NONFLAMMABLE CLEANER WHEN CLEANING THE UNIT!** Failure to do so can result in death, explosion, and/or fire.
-  **DO NOT LEAVE THE UNIT UNATTENDED AROUND CHILDREN!** Failure to do so can result in injury, and/or death.
-  **CAUTION: THE POWER SYSTEM IS HEAVY.** You must use proper lifting techniques. Failure to do so can result in injury.
-  **AVOID USING AN EXTENSION CORD WITH THE UNIT!** If an operational error occurs, the plug should be immediately removed from the socket.
-  **THE MAINS SOCKET SHOULD BE EASILY ACCESSIBLE!** If an extension cord must be used, ensure it is rated for the power capacity of the unit.
-  **THIS CHARGER IS DESIGNED FOR USE WITH LITHIUM POLYMER BATTERIES!** For safety reasons, this charger must be used only for batteries which have the right number of cells in series: Output divided by 4.1V or 4.2V.
-  **DO NOT OPEN THE POWER SYSTEM!** Unauthorized personnel opening the power system may cause injury and/or death. If the unit is not working properly, please contact Enovate Medical at 888-909-8930
-  **DO NOT USE THE UNIT IN/NEAR WATER OR OTHER LIQUIDS!** If the unit becomes wet, unplug it immediately, wipe away any excess liquid and allow it to dry before use. Failure to do so may cause electric shock, damage to the unit, voiding of warranty, injury or death.
-  **ALWAYS KEEP THE UNIT WELL VENTILATED!** Do not block ventilation airways or insert items into the ventilation slots. Failure to do so can cause the power system to overheat and possibly cause fire, explosion, and/or death.
-  **THE CHARGER CONTAINS DANGEROUS VOLTAGES AND THE COVER SHOULD NOT BE REMOVED.** All service or maintenance work should be carried out by qualified service personnel by contacting Enovate Medical at 888-909-8930

SAFETY GUIDELINES:

MOBIUS POWER is designed to ensure both the highest level of product quality and safety for the user. To maintain both quality and safety, follow the guidelines and instructions in this manual.

- Use the MOBIUS POWER system only as intended.
- Do not place the power system near a window. Exposing the power system to rain, water, moisture, or constant, direct sunlight can severely damage it.
- The MOBIUS POWER system has no user-serviceable, internal parts. To maintain your warranty, refer all servicing to Enovate Medical qualified personnel.
- Do not cover or obstruct any venting holes on the MOBIUS POWER Main Power Controller or the MOBIUS POWER Charging Stations.
- Store the MOBIUS POWER system within 10 to 30 degrees Celsius (50 to 86 degrees Fahrenheit). Storing the system outside the temperature range could result in permanent damage.
- Use and maintain the cord set provided with the MOBIUS POWER Charging Stations.
- If any cord or cable is frayed or damaged, replace it immediately with another of the same type and rating as supplied by Enovate Medical.
- To clean the exterior of the power system/components, follow the UL 60601-1 standard for use in a hospital environment. See "Cleaning Procedures" for more information.
- Before cleaning a MOBIUS POWER Charging Station, disconnect the enclosure from its power source.
- **CAUTION!** Do NOT ship individual MOBIUS POWER Battery Packs by air. Certain restrictions apply. Contact Enovate Medical for shipping instruction.

TRANSPORT/STORAGE

- Care should be taken to transport and store this system within a temperature range of 32° F to 90° F (0° C to 32° C); Pressure 500 hPa to 1060 hPa; Humidity 20% RH to 95% RH non-condensing.

STORAGE REQUIREMENTS:

- The Battery Pack must not be fully charged prior to storing.

CLASSIFICATIONS

- Charger: Class 1
- Main Controller: Class 1, Internally Powered
- Degree of Protection against Harmful Ingress of Water, IPX0
- EQUIPMENT not suitable for use in the presence of a FLAMMABLE ANAESTHETIC MIXTURE WITH AIR or WITH OXYGEN OR NITROUS OXIDE.

ENVIRONMENTAL SPECIFICATIONS

- Operating Temperature: -25°C to 40°C
- Relative Humidity: 5 – 95% non-condensing

WARRANTY

- Product Warranty: 1 year limited warranty on Battery Packs and 2 years on electronic components
- Extended Warranty: 1 year optional extension available on electronic components
- Contact Stinger Medical/Enovate Medical directly for full warranty details Approvals

ETL/CETL LISTING FOR NORTH AMERICA

- UL 60601-1 - UL Standard for Safety Medical Electrical Equipment, Part 1: General Requirements for Safety First Edition
- CSA C22.2 NO 601.1-M90 - Issue:1990/01/11 (R2001) Medical Electrical Equipment - Part 1: General Requirements for Safety General Instruction No 1; Supplement 1; 1994; Amendment 2 - February 1998 (R1997)
- Information Technology Equipment – Safety – Part 1: General Requirements, UL60950-1, First Edition.
- CAN/CSA-C22.2 No. 60950-1-03, First Edition.

MEDICAL DEVICE DIRECTIVE 93/42/EEC - EUROPEAN UNION (EU) TESTING AND REPORT SERVICES

- CENELEC EN 60601-1 - Medical Electrical Equipment Part 1: General Requirements for Safety Incorporates Corrigendum July 1994; Includes Amendments A1: 1993, A11: 1993, A12: 1993, A2: 1995 and A13: 1996; IEC 601-1: 1988 + A1: 1991 + A2: 1995 + Corrigendum 1995, Modified
- IEC 60601-1-2 (2001-09) - Medical Electrical Equipment - Part 1-2: General Requirements for Safety - Collateral Standard: Electromagnetic Compatibility - Requirements and Tests Second Edition

CB SCHEME REPORT AND CERTIFICATE

- IEC 60601-1 - Medical Electrical Equipment Part 1: General Requirements for Safety Second Edition

EMI (Electromagnetic Interference)

Portable and mobile RF communications equipment can affect Medical Electrical Equipment. The use of accessories, transducers, and cables other than those specified by the manufacturer, may result in increased Emissions or decreased Immunity of the System. The System should not be used adjacent to or stacked with other equipment and that if adjacent or stacked use is necessary, the System should be observed to verify normal operation in the configuration in which it will be used.

These limits are designed to provide reasonable protection against harmful interference in a residential installation. This equipment generates, uses, and can radiate radio frequency energy, and if not installed and used in accordance with the instruction manual, may cause interference to radio communications. However, there is no guarantee that interference will not occur in a particular installation. If this equipment does cause harmful interference to radio, television or Medical Electrical Equipment reception, which can be determined by turning the equipment off and on, the user is encouraged to try to correct the interference using one or more of the following measures: reorient or relocate the receiving antenna; increase the separation between the equipment and the receiver; connect the equipment into an outlet on a circuit different from that which the receiver is connected; consult the dealer or an experienced radio/television technician for help. The user must use shielded cables and connectors with this product.

Any changes or modifications to this product not expressly approved by the party responsible for compliance could void the user's authority to operate the equipment. Operation is subject to the following two conditions: (1) This device may not cause harmful interference, and (2) This device must accept any interference received, including interference that may cause undesired operation. MOBIUS POWER meets or exceeds FCC Class A limits for EMI.

Overview

- 1** LCD Message Center
 - 2** Battery Holster (Charger Board Inside)
 - 3** Main Power Controller (Main Control Board and DC Boards Inside)
 - 4** AC Holster Power Adaptor *
 - 5** Mobius Power Battery Pack
 - 6** 2-Battery Charging Station *
 - 7** 4-Battery Charging Station *
 - 8** Charging Indicator Light
 - 9** Indicator Light Instructions on front of Charging Station
- *OPTIONAL components or system upgrades

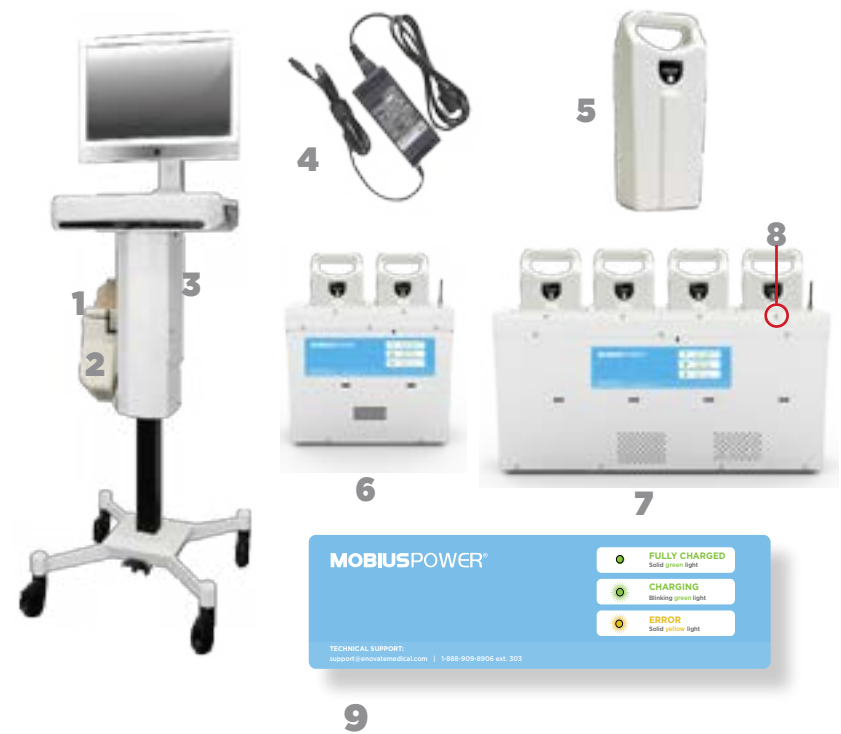

Unpacking



Cart Features

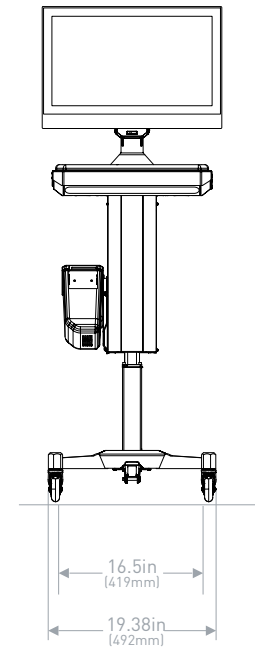
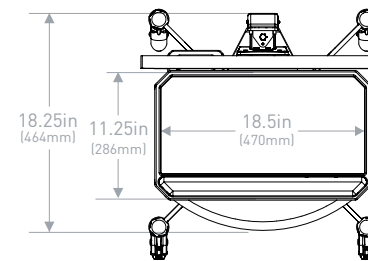
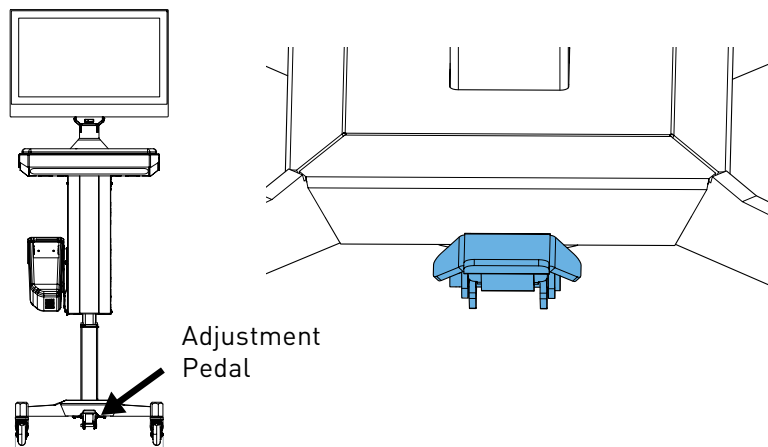
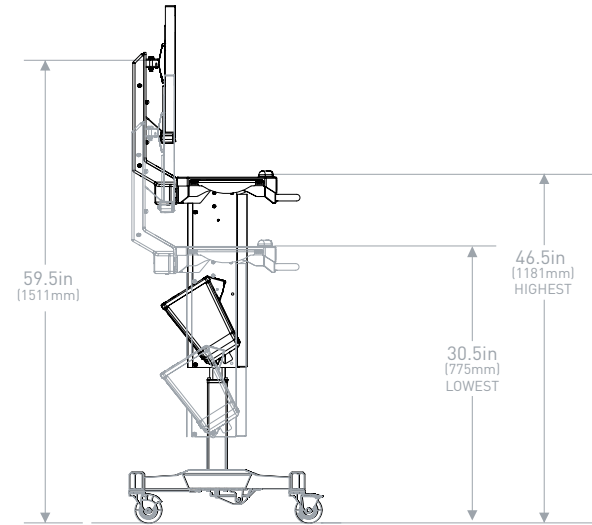
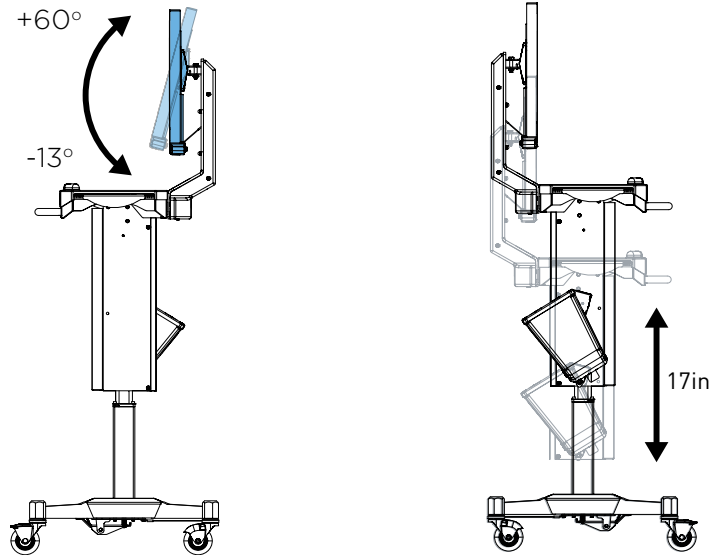

Power Systems

Each Battery Pack has a “fuel gauge” to indicate charge level/capacity.

- You may check a Battery Pack’s charge capacity at any time.
- To check the remaining charge on a Battery Pack, press and release the white circle on the Battery Pack’s fuel gauge display.
- The charge level is indicated in 25% increments by the number of status lights appearing between the E-Empty and F-Full.
- After 3 seconds, the status lights will turn OFF.

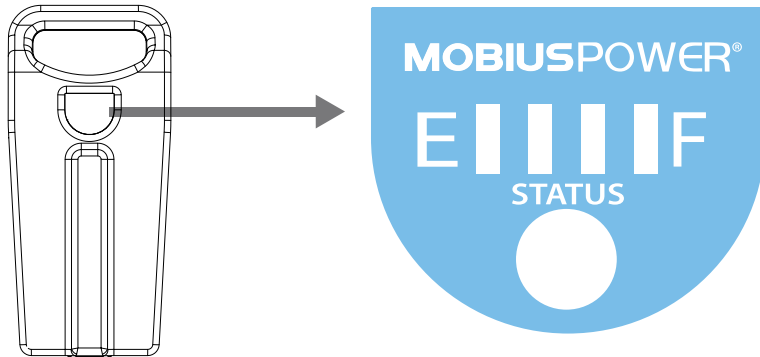

Charge Capacity	LED 1	LED 2	LED 3	LED 4
E █ █ █ █ F 0% – 10%	FLASH	OFF	OFF	OFF
E █ █ █ █ F 11% – 25%	ON	OFF	OFF	OFF
E █ █ █ █ F 26% – 50%	ON	ON	OFF	OFF
E █ █ █ █ F 51% – 75%	ON	ON	ON	OFF
E █ █ █ █ F 76% – 100%	ON	ON	ON	ON

MOBIUS POWER QUICK REFERENCE GUIDE

Q: When do I need to change the Mobius Power Battery Pack?

TIME REMAINING ON BATTERY PACK

Calculating Remaining Time

The workstation is calculating the run time based on the current being drawn by the system.

08:25 Remaining Time

Once the time is calculated, the Battery Pack will show a continuous display of 'Time Remaining' in hours and minutes. With Nurse Sensor installed, the time will vary depending on usage amount.

LOW BATTERY WARNING CYCLE

Low Battery

25 minutes time remaining:
 - LCD displays 'Low Battery'
 - Audible alarm (single beep) will alert you every 100 seconds

Low Battery

20 minutes time remaining:
 - LCD displays 'Low Battery'
 - Audible alarm (double beep) will alert you every 75 seconds

Replace Battery

15 minutes time remaining:
 - LCD displays 'Replace Battery'
 - Audible alarm (two beeps) will alert you every 50 seconds

Replace Battery

10 minutes time remaining:
 - LCD displays 'Replace Battery'
 - Audible alarm (single beep) will alert you every 20 seconds

System Shutdown

5 minutes time remaining:
 - LCD displays 'System Shutdown'
 - The Mobius SD application is doing an orderly shutdown of Windows because the battery charge level is very low.

Once the Battery Pack charge capacity is depleted, the LCD Message Center will turn off. At this point, MOBIUS POWER, your computer and any other devices requiring power will shut down until the Battery Pack is replaced with a Fully Charged Battery Pack OR the Battery Holster is plugged into an AC outlet using the optional Holster Charger. You may then turn on your computer and other electronic devices.

MOBIUS POWER Charging Station

Includes 2-Battery or 4-Battery Charging Stations Once the Charging Station is placed and plugged into an outlet, slide a Battery Pack into any open slot making sure the FLASHING GREEN indicator light turns on. The charge cycle is complete when the indicator light is illuminated SOLID GREEN.

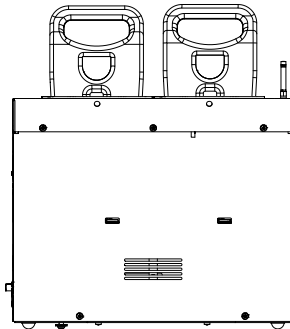

FULLY CHARGED
Solid green light



CHARGING
Blinking green light



ERROR
Solid or blinking yellow light

MOBIUS POWER Holster Charger

Use of the Holster Charger requires two connections. One end connects to the Battery Holster on your mobile cart and the other to an AC electrical outlet. After you connect the Holster Charger to both the Battery Holster and the electrical outlet, the LCD will read 'AC Powered'. Charge status can be checked by unplugging the Holster Charger from the wall outlet and reading the 'Time Remaining' on the LCD, or use the LEDs on the Battery Pack. Please refer to next page for the explanation of how to read the LEDs on each individual MOBIUS POWER Battery Pack.

BATTERY DISPOSAL

Industrial batteries contain materials which are considered 'hazardous substances'. If batteries are improperly disposed of, for example, thrown in the trash or illegally dumped, these substances can eventually leak out and contaminate the surrounding soil and groundwater supply.

It is a violation of federal law to improperly dispose of batteries once they can no longer be used. Once a battery is purchased, full liability and responsibility lies on the owner to dispose of the battery. The law says that responsibility is still on the owner if the battery is disposed of improperly by dumping in a landfill, or shipping to a scrap dealer who does not handle it properly and in which environmental damage occurs.

It is illegal to dispose of batteries in any way other than 'thermal recovery' or recycling of the hazardous substances in batteries according to the Environmental Protection Agency (EPA).

The Department of Transportation (DOT) has strict guidelines for the shipping of hazardous materials, which result in large fines if they are not followed.

Check with your local ordinances for proper disposal procedures.

MSDS sheets are available on-line at <http://www.enovatemedical.com>.

Batteries are consumable goods.

Recycling MOBIUS POWER Batteries - Rechargeable batteries power everything from portable phones and cordless phones to laptops and PDAs. Batteries are a unique product comprised of heavy metals which include nickel cadmium, alkaline, mercury, nickel metal hydride and lead acid, which can threaten our environment if not properly discarded or handled. There are many ways to properly dispose of batteries, most of which depends on the type of battery you have. Lithium-ion rechargeable batteries are less toxic than many others, but it is still recommended that they be recycled.

The Rechargeable Battery Recycling Corporation (RBRC) manages a collection and recycling program for rechargeable batteries. The RBRC accepts rechargeable nicad, NiMH, Lithium-Ion, and small (under 2-lb) sealed lead-acid batteries. The RBRC has made it very convenient for you to recycle your rechargeables by getting retail stores like Home Depot, Target, Wal-Mart, and others to serve as collection points. And it's all free of charge. To find a drop-off point near you in the US or Canada, use the RBRC Locator tool at <http://www.rbrc.org/call2recycle/dropoff/index.php>.

Remember: Batteries enable our mobility, so it's likely our society will be using a lot more batteries in the future. But to ensure that we're not slowly poisoning our highly mobile selves, it's important that we do a good job of recycling batteries.

Power Specifications

BATTERY SPECIFICATIONS

» One Year Battery

- Lithium Ion (LiCo02)
- 26 AH
- All cross compatible
- Charge Time: 26AH < 4hrs
- Measurements: 10" H x 5" W x 3.14 D
- Weight: 4.8lbs

» Four Year Battery

- Lithium Ion (LiCo02)
- 26 AH
- All cross compatible
- Charge Time: 26AH < 4hrs
- Measurements: 10" H x 5" W x 3.14 D
- Weight: 4.8lbs

CHARGING STATION SPECIFICATIONS

» Dual Charging Station

- Standard 110 VAC Outlet
- Protection 15A 250V
- Input Voltage: 120V +/- 10%
- Input Frequency: 60Hz
- Input Current: 3.6 Amps max
- Output Voltage: 12.6 VDC
- Output Current: 8.5 A per bay (max)
- Output Power: 110 Watts (max) per bay
- Measurements: 12.6" H x 17" W x 5.8"D

» Quad Charging Station

- Standard 110 VAC Outlet
- Standard 15 AMP Breaker
- Input Voltage: 120V +/- 10%
- Input Frequency: 60Hz
- Input Current: 7.2 Amps max
- Output Voltage: 12.6 VDC
- Output Current: 8.5 A per bay (max)
- Output Power: 110 Watts (max) per bay
- Measurements: 12.6" H x 27" W x 5.8" D

MAIN CONTROLLER SPECIFICATIONS

» Power Controller

- Output Voltage: 2 Channels variable 5 VDC – 12 VDC
- Output Voltage: 2 Channels variable 12 VDC – 24 VDC
- Input Voltage: 11.1 VDC nominal
- Input Voltage Range: DC 9.6-12.6V
- Input Current: 14.9 (max)
- Output Protection: Yes
- Output Power: 115W Total for System
- Overload Recovery: Yes
- Overload Protection: Yes

HOLSTER SPECIFICATIONS

» Holster Charger

- Model: Protek Power PMP150-12-HI
- Input Voltage: 110 – 240 VAC
- Input Frequency: 47 – 63 Hz
- Input Current: 2 A (rms) for 115 VAC, 1 A (rms) for 230 VAC
- Output Voltage/Current: 12 VDC, 11 A
- Charge Time: Less than 7hrs
- Measurements: 9.6" H x 4.1" W x 7.5" D

System Electromagnetic Emissions

MEDICAL ELECTRICAL EQUIPMENT needs special precautions regarding EMC and needs to be installed and put into service according to the EMC information provided in the ACCOMPANYING DOCUMENTS.

WARNING: Use of unapproved ACCESSORIES may result in degradation.

Guidance and Manufacturer's Declaration – Cables, Transducers and Accessories

The listed cables, transducers and accessories have been determined by Enovate Medical to be compliant with the emissions and immunity requirements of IEC 60601-1-2: 2001.

Part No.	Description	Max Possible Length	Shielded (Y/N)
8115196	Cable, power 2.5 x 5.5 – Kycon KPP	84"	Y
8115197	Cable, power 2.1 x 5.5 – Kycon KPP	84"	Y
8115198	Cable, power Hirose A – Kycon KPP	84"	Y
8115199	Cable, power Kyron– Kycon KPP	84"	Y
8115200	Cable, power 3 pin din – Kycon KPP	84"	Y
8115201	Cable, power Kyron– Kycon KMDLA	84"	Y
8115202	Cable, power Dell combo power adapter	84"	Y
8115203	Cable, power 1.7 x 4.75 – Kycon KPP	84"	Y
8115204	Cable, power 2.5 x 5.5 locking barrel– Kycon KPP	84"	Y
8115275	Cable, serial for basic fuel board	72"	Y
8115360	Cable, 10 pin ribbon extension	18"	N
8114206	Cord Reel, IEC 48" pigtail 908 Ametek	10'	N
8116246	Cord Reel, IEC 48" pigtail 908 KeTe	10'	N

Table 201 – Guidance and manufacturer's declaration – electromagnetic emissions – for all EQUIPMENT and SYSTEMS (see 6.8.3.201 a)3])

Guidance and Manufacturer's declaration – electromagnetic emissions

MOBIUS POWER is intended for use in the electromagnetic environment specified below. The customer or the user of MOBIUS POWER should assure that it is used in such an environment.

Emissions Test	Compliance	Electromagnetic environment - guidance
RF emissions CISPR 11	Group 1	MOBIUS POWER uses RF energy only for its internal function. Therefore, its RF emissions are very low and are not likely to cause any interference in nearby electronic equipment.
RF emissions CISPR 11	Class A	MOBIUS POWER is suitable for use in all establishments other than domestic and those directly connected to the public low-voltage power supply network that supplies buildings used for domestic purposes.
Harmonic emissions IEC 61000-3-2	Not Applicable	
Voltage fluctuations/ flicker emissions IEC 61000-3-3	Not Applicable	

Table 206 – Recommended separation distances between portable and mobile RF communications equipment and the EQUIPMENT or SYSTEM – for EQUIPMENT and SYSTEMS that are not LIFE-SUPPORTING (see 6.8.3.201 b)

Recommended separation distances between portable and mobile RF communications equipment and the MOBIUS POWER.

MOBIUS POWER is intended for use in an electromagnetic environment in which radiated RF disturbances are controlled. The customer or the user of MOBIUS POWER can help prevent electromagnetic interference by maintaining a minimum distance between portable and mobile RF communications equipment (transmitters) and MOBIUS POWER as recommended below, according to the maximum output power of the communications equipment.

Rated maximum output power of transmitter W	Separation distance according to frequency of transmitter m		
	150 kHz to 80 MHz $d = [3.5/V1]eP$	80 MHz to 800 MHz $d = [3.5/E1]eP$	800 MHz to 2.5 GHz $d = [7/E1]eP$
0.01	0.12	0.12	0.23
0.1	0.38	0.38	0.73
1	1.2	1.2	2.3
10	3.8	3.8	7.3
100	12	12	23

For transmitters rated at a maximum output power not listed above, the recommended separation distance d in meters (m) can be estimated using the equation applicable to the frequency of the transmitter, where P is the maximum output power rating of the transmitter in watts (W) according to the transmitter manufacturer.

NOTE 1 At 80 MHz and 800 MHz, the separation distance for the higher frequency range applies.

NOTE 2 These guidelines may not apply in all situations. Electromagnetic propagation is affected by absorption and reflection from structures, objects and people.

Table 202 – Guidance and manufacturer’s declaration – electromagnetic immunity – for all EQUIPMENT and SYSTEMS (see 6.8.3.201 a)6)

Guidance and manufacturer’s declaration – electromagnetic immunity

MOBIUS POWER is intended for use in the electromagnetic environment specified below. The customer or the user of MOBIUS POWER should assure that it is used in such an environment.

Immunity test	IEC 60601 test level	Compliance level	Electromagnetic environment – guidance
Electrostatic discharge (ESD) IEC 61000-4-2	±6 kV contact ±8 kV air	±6 kV contact ±8 kV air	Floors should be wood, concrete or ceramic tile. If floors are covered with synthetic material, the relative humidity should be at least 30%
Electrical fast transient/burst IEC 61000-4-4	±2 kV for power supply lines ±1 kV for input/output lines	±2 kV for power supply lines ±1 kV for input/output lines	Mains power quality should be that of a typical commercial or hospital environment.
Surge IEC 61000-4-5	±1 kV differential mode ±2 kV common mode	±1 kV differential mode ±2 kV common mode	Mains power quality should be that of a typical commercial or hospital environment.
Voltage dips, short interruptions and voltage variations on power supply input lines IEC 61000-4-11	<5% UT (>95% dip in UT) for 0.5 cycle 40% UT (60% dip in UT) for 5 cycles 70% UT (30% dip in UT) for 25 cycles <5% UT (>95% dip in UT) for 5 sec	<5% UT (>95% dip in UT) for 0.5 cycle 40% UT (60% dip in UT) for 5 cycles 70% UT (30% dip in UT) for 25 cycles <5% UT (>95% dip in UT) for 5 sec	Mains power quality should be that of a typical commercial or hospital environment. If the user of the Mobius requires continued operation during power mains interruptions, it is recommended that the Mobius be powered from an uninterruptible power supply or a battery.
Power frequency (50/60 Hz) magnetic field IEC 61000-4-8	3 A/m	3 A/m (60Hz)	Power frequency magnetic fields should be at levels characteristic of a typical location in a typical commercial or hospital environment.

NOTE: UT is the a.c. mains voltage prior to application of the test level.

Table 204 – Guidance and manufacturer’s declaration – electromagnetic immunity – for EQUIPMENT and SYSTEMS that are not LIFE-SUPPORTING (see 6.8.3.201 b)

Guidance and manufacturer’s declaration – electromagnetic immunity
MOBIUS POWER is intended for use in the electromagnetic environment specified below. The customer or the user of MOBIUS POWER should assure that it is used in such an environment.

Immunity test	IEC 60601 test level	Compliance level	Electromagnetic immunity - guidance
Conducted RF IEC 61000-4-6	3 Vrms 150 kHz to 80 MHz	3 V 3 V/m	Portable and mobile RF communications equipment should be used no closer to any part of the MOBIUS POWER including cables, than the recommended separation distance calculated from the equation applicable to the frequency of the transmitter. Recommended separation distance $d = [3.5/V1]eP$ $d = [3.5/E1]eP$ 80 MHz to 800 MHz $d = [7/E1]eP$ 800 MHz to 2.5 GHz where P is the maximum output power rating of the transmitter in watts (W) according to the transmitter manufacturer and d is the recommended separation distance in meters (m). Field strengths from fixed RF transmitters, as determined by an electromagnetic site survey, a should be less than the compliance level in each frequency range. b Interference may occur in the vicinity of equipment marked with the following symbol:
Radiated RF IEC 61000-4-3	3 V/m 80 MHz to 2.5 GHz		

NOTE 1 At 80 MHz and 800 MHz, the higher frequency range applies

NOTE 2 These guidelines may not apply in all situations. Electromagnetic propagation is affected by absorption and reflection from structures, objects and people.

a Field strengths from fixed transmitters, such as base stations for radio (cellular/cordless) telephones and land mobile radios, amateur radio, AM and FM radio broadcast and TV broadcast cannot be predicted theoretically with accuracy. To assess the electromagnetic environment due to fixed RF transmitters, an electromagnetic site survey should be considered. If the measured field strength in the location in which MOBIUS POWER is used exceeds the applicable RF compliance level above, MOBIUS POWER should be observed to verify normal operation. If abnormal performance is observed, additional measures may be necessary, such as reorienting or relocating MOBIUS POWER.

b Over the frequency range 150 kHz to 80 MHz, field strength should be less than [3] V/m.



1152 Park Avenue
Murfreesboro, TN 37129
p. (888)909-8930 f. (615)896-1652

www.enovatemedical.com
support@enovatemedical.com

©2013 Enovate Medical LLC. All Rights Reserved