

# 1503

## Series High Speed Servo Motor



# Manual

***PUSHCORP, INC.***

---

Dallas, Texas

May, 2007

## **! CAUTION !**

Do **NOT** apply air pressure to release the Collet while the servo motor is rotating. The servo motor spindle must be ***FULLY STOPPED*** before actuating the Collet.

Do **NOT** overheat the servo motor. Supply the motor cooling water to maintain a temperature below **176 °F (80 °C)**.

Do **NOT** start or stop the servo motor instantaneously. Doing so will damage the motor and power amplifier.

All *PushCorp, Inc.* electrical cables are rated for high twist and flex robotic applications with a minimum cable bending radius specification of 125mm (5 in). Cable damage resulting from failure to abide by this specification will not be covered under warranty.

## ***Table of Contents***

<b>1.0 LIMITED WARRANTY</b>	<b>1</b>
<b>2.0 GENERAL OVERVIEW</b>	<b>3</b>
<b>3.0 INSTALLATION &amp; OPERATION</b>	<b>4</b>
3.1 Mounting the 1503	4
3.1.1 Mounting to an AFD1000/70	4
3.1.2 Mounting Directly to a Robot	6
3.2 Media and Tool Presentation	6
3.3 Tool and Media Specification	7
3.3.1 STC1503 & SM1503 Toolholder Specification	7
3.3.3 STC1503-BT30 Toolholder Specification	9
3.4 SM1503 Collet Operation	10
3.4.1 SM1503 Collet Assembly and Removal	10
3.5 Pneumatic Connection	11
3.6 Electrical Connections	13
3.7 Motor Cooling	15
3.8 Monitoring Motor Temperature	15
3.9 Motor Acceleration/Deceleration	17
<b>4.0 TECHNICAL SPECIFICATIONS</b>	<b>18</b>

## **1.0 Limited Warranty**

### **Duration:**

One year from date of delivery to the original purchaser.

### **Who gives this warranty (warrantor):**

*PushCorp, Inc.*

Telephone: (972) 840-0208

Corporate Address:

P. O. Box 181915

Dallas, Texas 75218

Shipping Address:

3001 W Kingsley Rd

Garland, Texas 75041

### **Who receives this warranty (purchaser):**

The original purchaser (other than for purposes of resale) of the *PushCorp, Inc.* product

### **What products are covered by this warranty:**

Any *PushCorp, Inc.* industrial equipment or accessory supplied or manufactured by the Warrantor.

### **What is covered under this warranty:**

Defects in material and/or workmanship which occur within the duration of the warranty period.

### **What is NOT covered in this warranty:**

- A. IMPLIED WARRANTIES, INCLUDING THOSE OF MERCHANTABILITY AND FITNESS FOR A PARTICULAR PURPOSE ARE LIMITED TO ONE YEAR FROM THE DATE OF ORIGINAL PURCHASE. Some states do not allow limitations on how long an implied warranty lasts, so the above limitations may not apply to you.
- B. ANY INCIDENTAL, INDIRECT, OR CONSEQUENTIAL LOSS, DAMAGE or EXPENSE THAT MAY RESULT FROM ANY DEFECT, FAILURE, MALFUNCTION OF THE *PUSHCORP, INC.* PRODUCT. Some states do not allow the exclusion or limitation of incidental or consequential damages so the above limitation or exclusion may not apply to you.
- C. Any failure that results from an accident, purchaser's abuse, neglect, unauthorized repair or failure to operate the products in accordance with the instructions provided in the owner's manual(s) supplied with the product.

### **Responsibilities of the Warrantor under this warranty:**

Repair or replace, at Warrantor's option, products or components which have failed within the duration of the warranty period.

**Responsibilities of the purchaser under this warranty:**

- A. Deliver or ship the *PushCorp, Inc.* product or component to PushCorp, Inc. Service Center, Dallas, TX. Freight and insurance costs, if any, must be borne by the purchaser.
- B. Use reasonable care in the operation and maintenance of the product as described in the owner's manual(s).

**When warrantor will perform repair or replacement under this warranty:**

Repair or replacement will be scheduled and serviced according to the normal work flow at the service center, and depending on the availability of replacement parts. Purchasers requiring quicker repair may receive such with payment of a *PushCorp, Inc.* predetermined expediting fee.

This Limited Warranty gives you specific legal rights and you may also have other rights which vary from state to state.

## 2.0 General Overview

The PushCorp 1503 Series Servo Motors are capable of continuously producing 3 horsepower, and spinning up to 15000 rpm. The 1503 series includes three versions; an SM1503 manual collet, an automatic version with a collapsing collet, STC1503 and another automatic version which clamps a BT30 toolholder, STC1503-BT30. The 1503 Series utilizes identical motor windings, and power amplifiers. Differing only in a few physical dimensions and how they secure the media. Each of these motors provide a convenient and effective means to spin and/or change any number of different media types to support a fully automated workcell.

The SM1503 has a manually tightened collet that is a cost-effective alternative to the automatic version. The SM1503 uses the same motor winding and housing as the STC1503, but without the automatic clamping mechanism. The manual Collet is a standard ER-20 series collet designed to clamp a ½ inch (12.7 mm) diameter Toolholder. The user may choose different sized collets in the ER-20 series, ranging from .031-.500 inch (1mm – 13mm).

The STC1503 Series has two different automatic tool-changing versions, each actuating pneumatically to clamp the shaft or toolholder. They are comprised of four primary components: a high-torque Servo Motor, a pneumatic actuator, high force Belleville springs, and a component to clamp a Toolholder. The STC version uses a drawbar to pull the Collet/Gripper in. High force Belleville springs located at the back of the Servo Motor tension the drawbar. Actuating the large pneumatic actuator, located in the Clamping Housing, opens the Collet/Gripper. During pressurization the cylinder contacts the Belleville springs and compresses them to drive the Collet/Gripper out, releasing the Toolholder. There is no mechanism to forcibly eject the Toolholder from the Collet, so gravity or a capturing mechanism must be used.

The STC1503 version uses a PushCorp proprietary collapsing collet to lock around the Toolholder. The STC1503-BT30 uses a 30 taper to grip a standard BT30 toolholder. This design locks the toolholder in the 30 tapered shaft and resists large pull out forces. The shaft does not have locking keys, so motor indexing for tool change is not required. The SM1503 uses a manually operated collet to simplify its operation, with the additional benefit of lower up-front cost. Both of the STC1503 motors are fail-safe, in that no air pressure is required to hold the Toolholder. Therefore, the Toolholder will remain held in the Collet/Gripper even when the air pressure is un-expectantly lost. Likewise, applying air pressure to a single input port via a simple manual or electrically operated valve opens the Collet/Gripper and releases the Toolholder. Finally, this clever mechanical design always isolates the motor bearings from the drawbar tension. This greatly improves reliability by allowing the motor shaft to spin freely and never be subject to any clamping forces. Each member of the 1503 Series uses sealed bearings to insure a long life. The 1503 bearings have additional contamination protection from a PushCorp proprietary contact shaft seal. This special seal eliminates the need for constant purge air.

During operation the 1503 generates considerable heat due to the high torque and compact size of the motor. Excessive operating temperatures will significantly reduce the life of the motor. Water Cooling is required to keep the unit within the internal temperature operating range. The motor should never be allowed to exceed a temperature of 176 °F (80 °C). Continuously operating the unit above 176 °F (80 °C) will cause the rotor to de-magnetize and the bearings to fail. High temperatures will

also cause the O-rings that seal the cooling water channels to fail, possibly filling the motor with water. PushCorp has provided flow through water cooling on the motor to allow high duty cycles without overheating.

Simple reliable construction combined with high torque and precision speed controlled servo technology make the *PushCorp* 1503 Servo Motor line a rugged, state-of-the-art tool capable of providing flexible, cost-effective operations.

## **3.0 Installation & Operation**

### **3.1 Mounting the 1503**

#### **3.1.1 Mounting to an AFD1000/70**

The 1503 Motors are designed to attach directly to the Carriage of any *PushCorp* AFD1000/70 Force Device. There are two standard attachment options. The SM1503 uses a Mounting Plate, and both STC motors use the Clamping Housing for attachment.

The Parallel-Axis configuration is shown in Figure 1, where the 1503 attaches to the AFD Carriage with a Parallel Bracket. The Parallel Bracket is positioned on the Carriage and attached using the four (4) supplied M6x1x20mm Socket Head Cap Screws. The 1503 is then attached to the Parallel Bracket, as shown, with two (2) M6x1x20mm Socket Head Cap Screws into the front of the Motor Housing. Two (2) M6x1 Socket Head Cap Screws pass through the Clamping Housing/Mounting Plate (length is dependent on motor SM1503 = 25mm, STC1503 = 100mm, STC1503-BT30 = 145mm). The fasteners must be tightened to the torque specified in Section 4.0.

To attach the 1503 to an AFD in a Perpendicular-Axis configuration, position the Clamping Housing/Mounting Plate over the Carriage as shown in Figure 2. Then secure the unit using four (4), M6x1 Socket Head Cap Screws (length is dependent on motor SM1503 = 25mm, STC1503 = 100mm, STC1503-BT30 = 145mm). Tighten the fasteners to the torque specified in Section 4.0. 5mm Dowel pins can be inserted and glued into the Carriage to align the 1503. The Clamping Housings and Mounting Plate have pre-drilled clearance dowel holes for this configuration.

**CAUTION:** Make sure that the M6x1 fasteners do not exceed a depth of 0.40" (10 mm) into the AFD Carriage Helicoils or damage will occur.

**CAUTION:** Do not press Dowel Pins into the AFD Carriage, this will damage the linear rails.

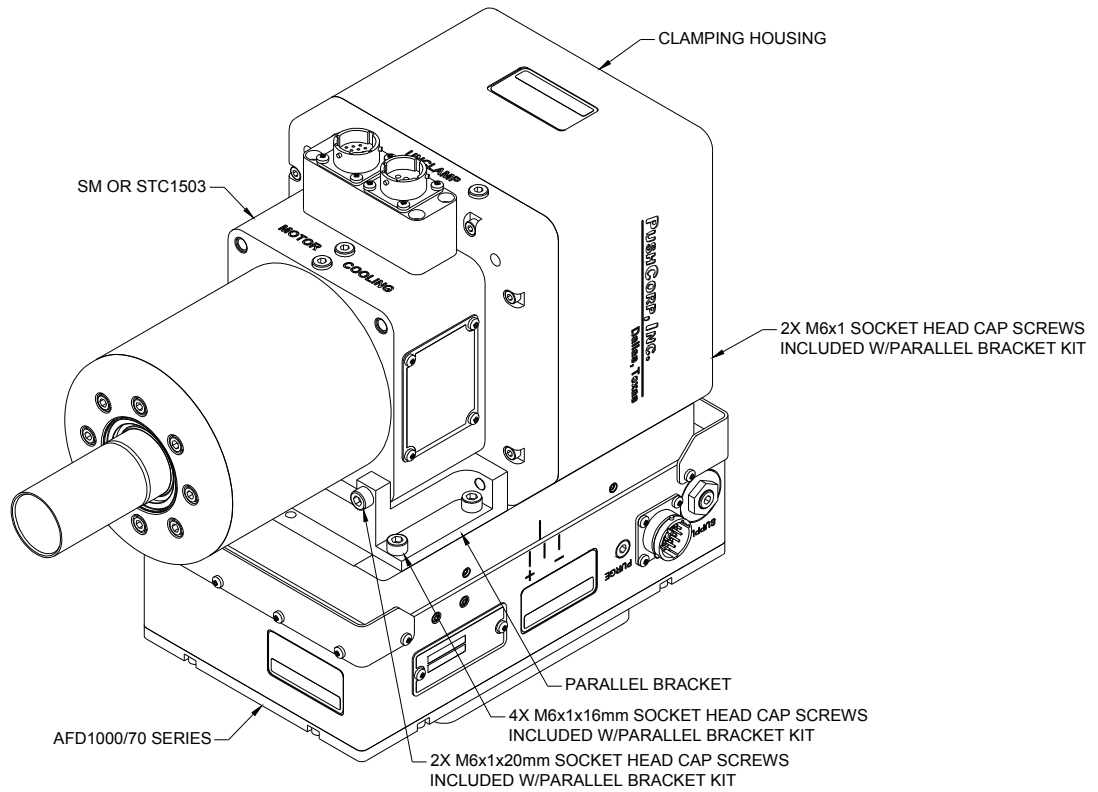

**Figure 1. 1503 Parallel-Axis Configuration**

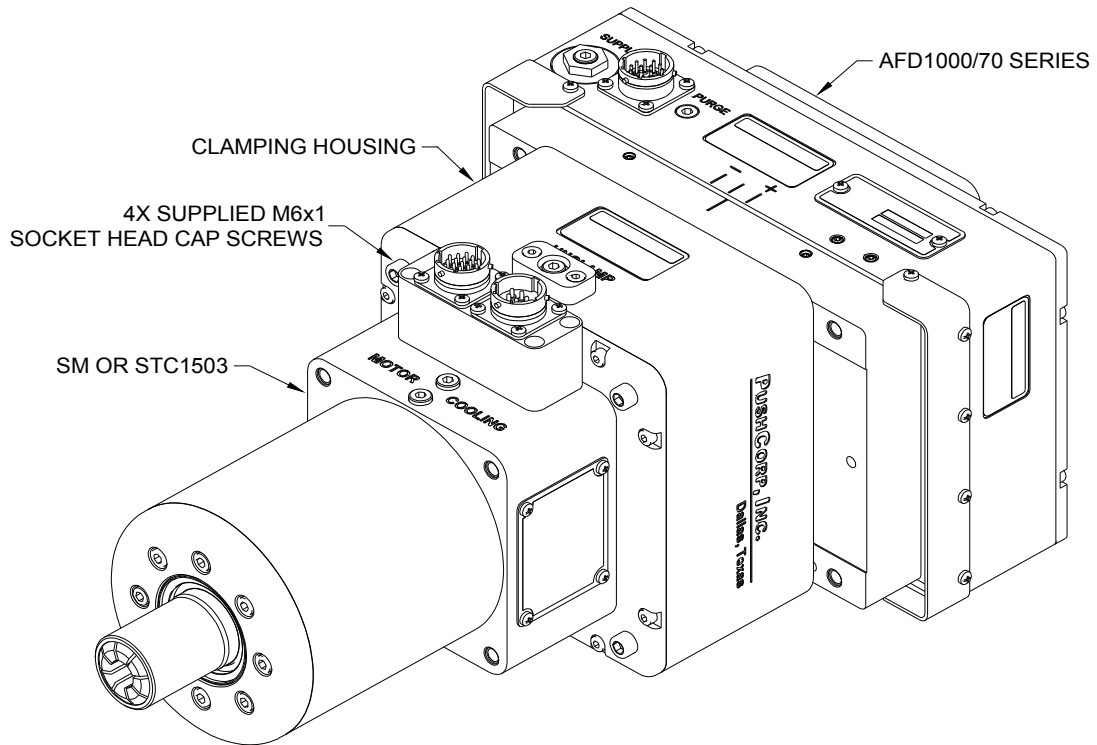

**Figure 2. 1503 Perpendicular-Axis Configuration**



### 3.1.2 Mounting Directly to a Robot

For some processes compliance and force control are not required. The 1503 Series can be mounted directly to the robot, in these cases, and the system can be operated in position mode. This robotic system is equivalent to a 5-axis machining center with a very large work volume and lower positional accuracy. Certain product types and processes are well suited for a Robotic Machining Center (RMC).

The 1503 Series can be attached to the robot mounting flange using a customer supplied mounting plate. For direct mounting it is recommended that a breakaway clutch is installed. The breakaway clutch will help protect the motor in the event of a robot crash. Loads on the motor shaft of over 300 lb (136 kg) radially and 150 (68 kg) axially will damage the bearings.

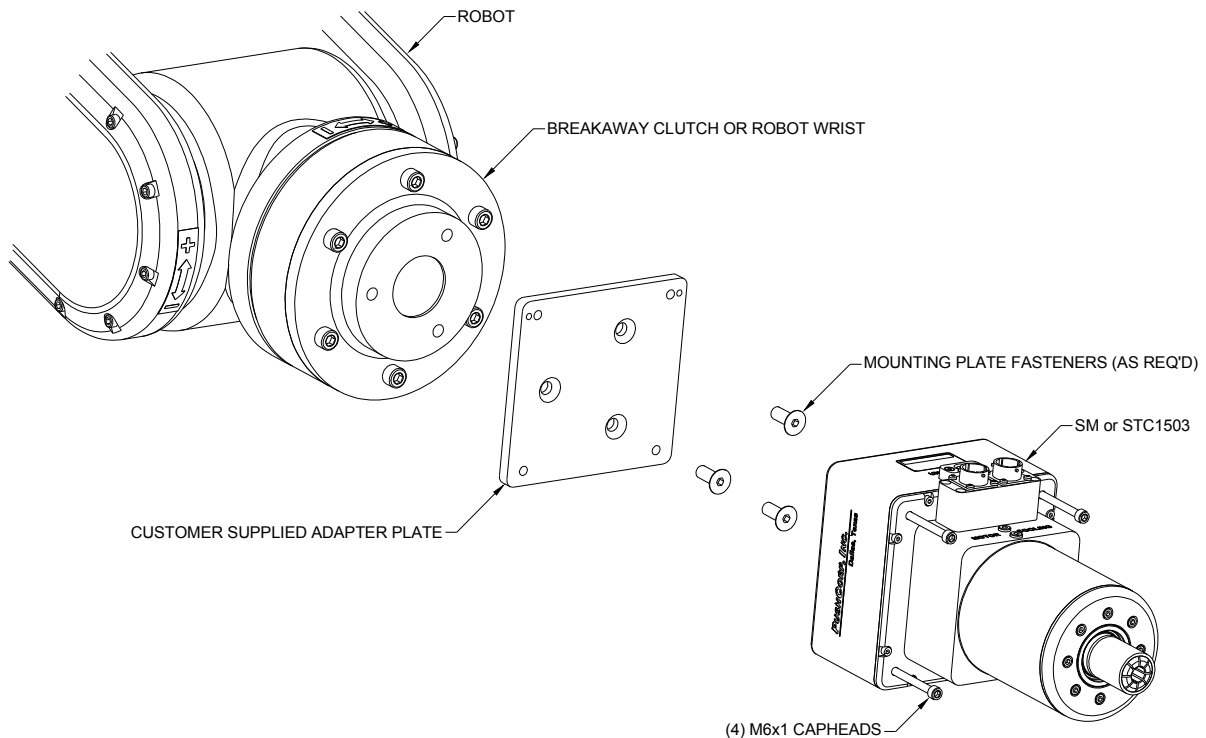

Figure 3. STC1503 Direct Mounting

To mount the 1503, first attach the customer supplied Mounting Plate to the Robot Mounting Flange or to the Breakaway Clutch, per the manufacturer's specifications. Once the Mounting Plate is secured, place the 1503 Series against the Mounting Plate and install (4) four, M6x1, Socket Head Cap Screws (length is dependent on motor SM1503 = 25mm, STC1503 = 100mm, STC1503-BT30 = 145mm). (See Figure 3.) Tighten the fasteners to the torque specified in Section 4.0.

### 3.2 Media and Tool Presentation

Media and tool presentation refers to how various disks, drill bits, router bits, etc. are presented so that a robot may maneuver the STC1503 into position to grasp the Toolholder reliably. It is ultimately the user's responsibility to provide a means to present the media and/or tooling in an effective and repeatable way for a given application.

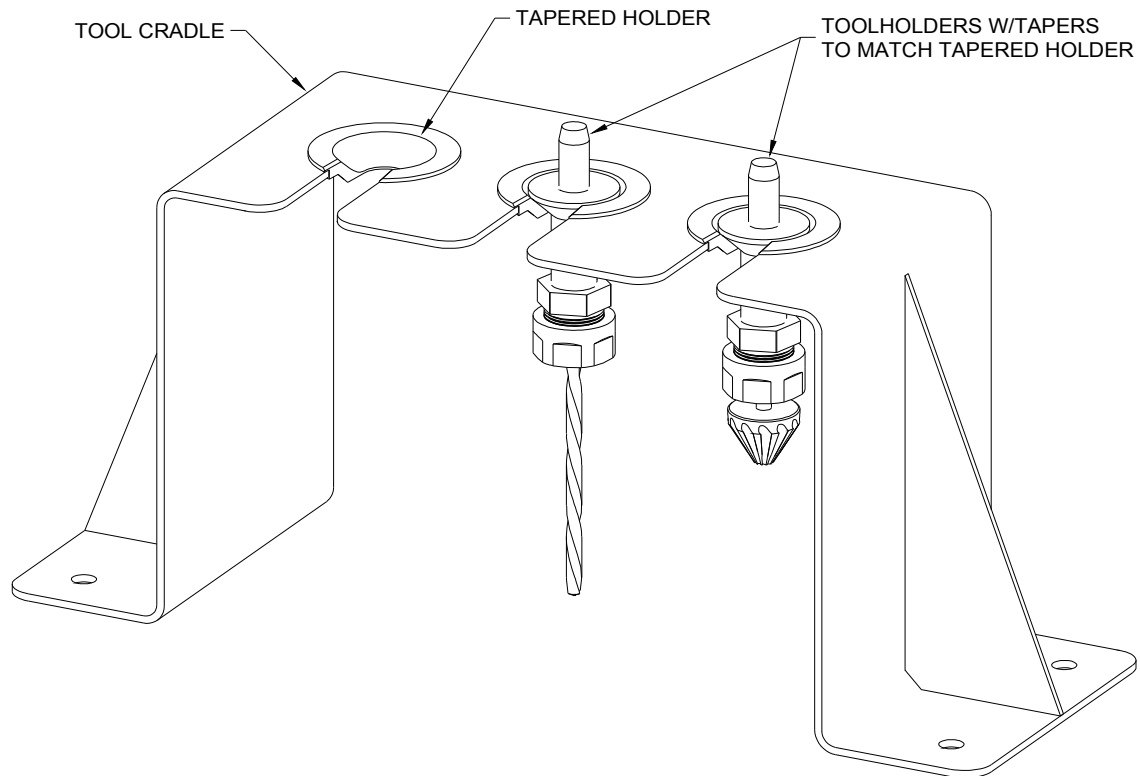

Figure 4. Sample media and tooling presentation scheme

As shown above, in Figure 4, many types of media and tools may be accurately located in a Tool Cradle. A robot can then be taught approach paths and docking locations to reliably bring the STC1503 down over the Toolholders and grasp them. The STC1503 Collapsing Collet allows 0.015 in. (0.38 mm) diametrical clearance around the Toolholder when open. The Toolholder must have a taper that mates to a Tapered Holder mounted in the Tool Cradle. The Tapered Holder requires a slot to allow the Toolholder to pass through. This same method is applicable to the STC1503-BT30 design.

### 3.3 Tool and Media Specification

#### 3.3.1 STC1503 & SM1503 Toolholder Specification

The STC1503 and SM1503 are designed to grasp a ½ inch (12.7 mm) diameter steel shaft. Figure 7 shows the Toolholder dimensions required for the STC1503 to operate properly. Notice that the end of the Toolholder can be tailored to any needed configuration to attach to various disk back-up pads, drill bits, router bits, grinding stones, etc. If desired, *PushCorp, Inc.* can fabricate custom Toolholders, at an additional cost, based on customer supplied drawings and specifications. To prevent interference between the Toolholder and the Collet an 11° taper must be included in all Toolholder designs. Toolholders should be manufactured from carbon or stainless steel with a hardness less than Rc40. The surface finish on the Toolholder Clamping Surface should be Ra 16 – 32. To accurately locate the Toolholder axially the front flat surface of the Collet can be used. This means that the Toolholder Clamping Surface and taper must be shorter than the Collet depth. When using the Collet face for positioning some form of compliance must be used on the Tool Cradle to prevent wedging the Collet in too tightly, or damaging the motor bearings.

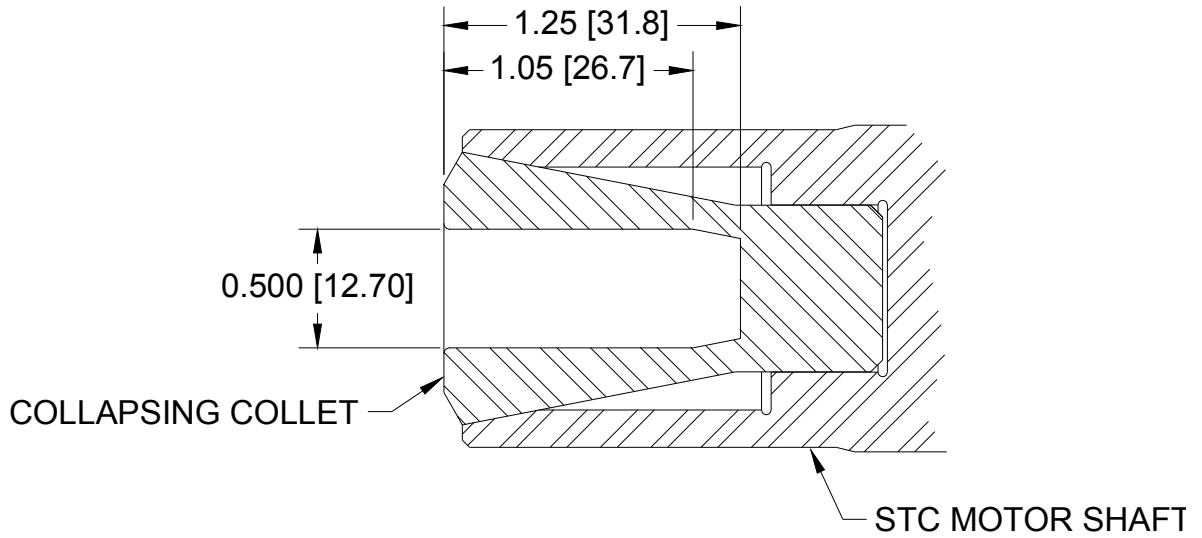

Figure 5. STC1503 Collet Drawing

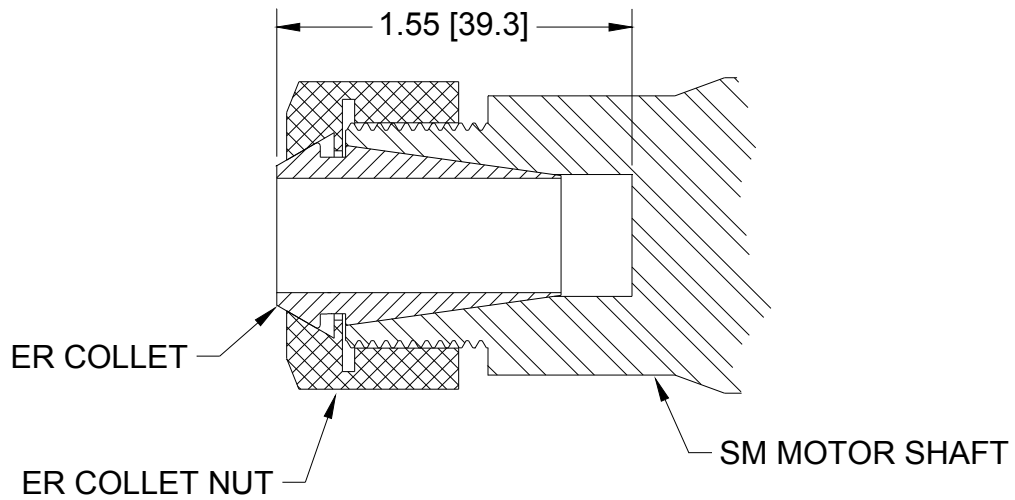

Figure 6. SM1503 Collet Drawing

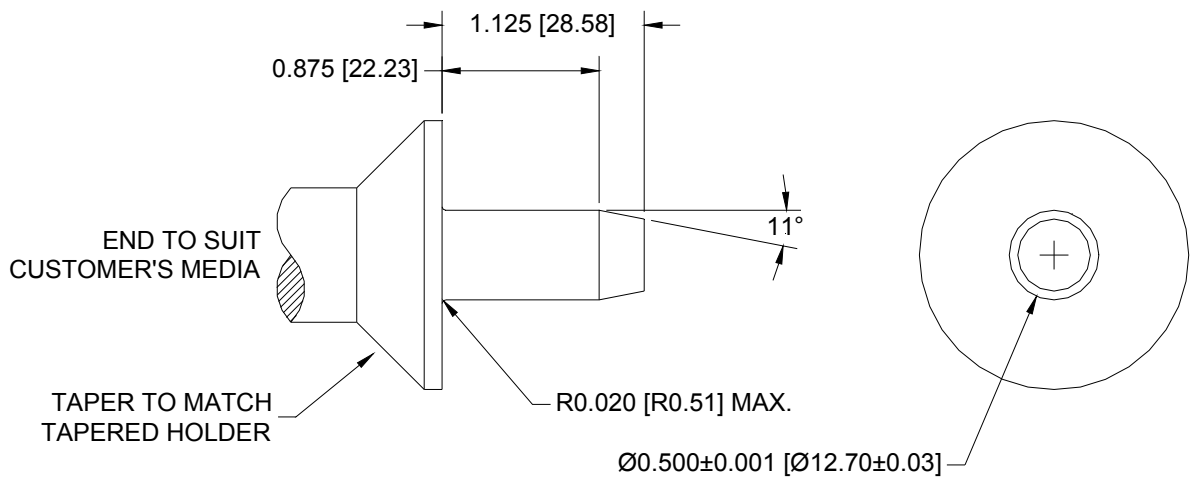
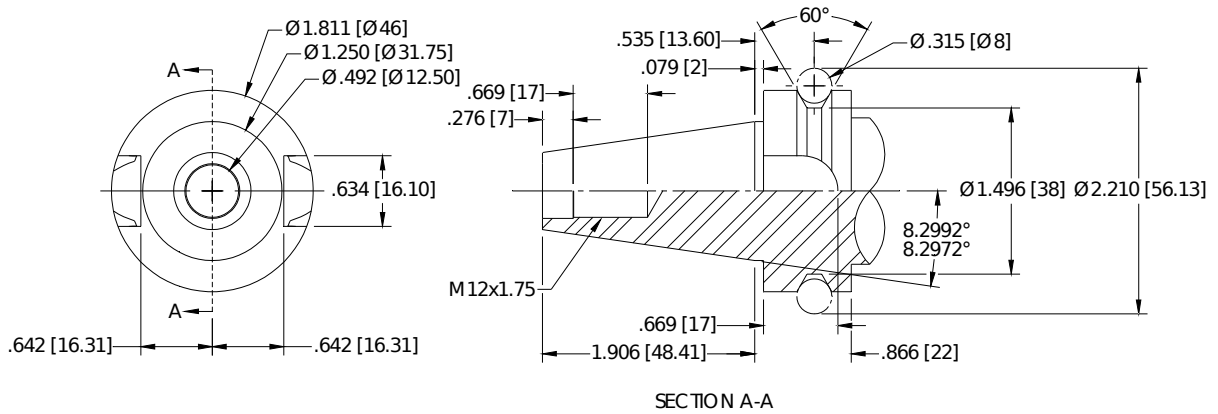

Figure 7. STC1503 & SM1503 Toolholder Drawing

**3.3.3 STC1503-BT30 Toolholder Specification**

The STC1503-BT30 is designed to grip a BT30 toolholder. The BT30 toolholder is a standard machine tool style and may be purchased from several sources including, MSC ([www.msc.com](http://www.msc.com)), and J & L Industrial Supply ([www.jlindustrial.com](http://www.jlindustrial.com)). The Customer can also make their own BT30 toolholder to handle special media (See Figure 8 for toolholder dimensions). The toolholder must be equipped with a Parlec ([www.parlec.com](http://www.parlec.com)) retention knob, part number 3003TRK, or equivalent. Figure 9 shows the Parlec retention knob with the required dimensions.



SECTION A-A  
Figure 8. BT30 Toolholder Dimensions

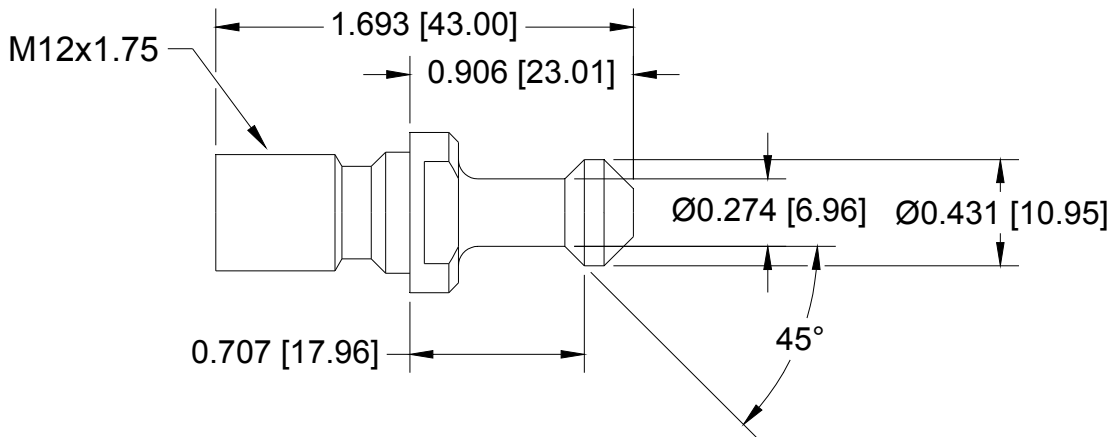

Figure 9. BT30 Retention Knob

### 3.4 SM1503 Collet Operation

The Collet for the SM1503 is tightened and loosened manually. The Motor Shaft must be held using the Motor Shaft Flats, while the Collet Nut is turned, see Figure 13. Turning the Collet Nut clockwise forces the Collet into the Motor Shaft causing it to clamp around the Toolholder. To loosen the Collet, rotate the Collet Nut counter-clockwise. If the Collet is to be removed, continue rotating the Collet Nut counter-clockwise and the Collet Nut and Collet will come off together. The Collet is an ER Series (DIN 6499 Form B) Size 20. The recommended tightening torque for the Collet Nut depends on the bore diameter of the Collet. For Collet bore diameters 0.276 – 0.512 in. (7.0 – 13.0 mm) the recommended tightening torque is 60 lb.-ft. (80 N·m), and not to exceed 75 lb.-ft. (100 N·m). For Collet bore diameters 0.039 – 0.256 in. (1.0 – 6.5 mm) the recommended tightening torque is 24 lb.-ft. (32 N·m), and not to exceed 30 lb.-ft. (40 N·m).

**CAUTION: Tightening toques greater than recommended will permanently deform the collet cavity of the toolholder.**

#### 3.4.1 SM1503 Collet Assembly and Removal

To assemble the Collet insert the Collet Groove into the Eccentric Ring of the Collet Nut. Push the Collet in while rotating the Collet up, until it clicks in. See Figure 10.

To remove the Collet, first unscrew the Collet Nut from the Motor Shaft. After the Collet Nut is unscrewed, press on the face of the Collet while simultaneously pushing sideways on the back of the Collet until it disengages from the Collet Nut. See Figure 10.

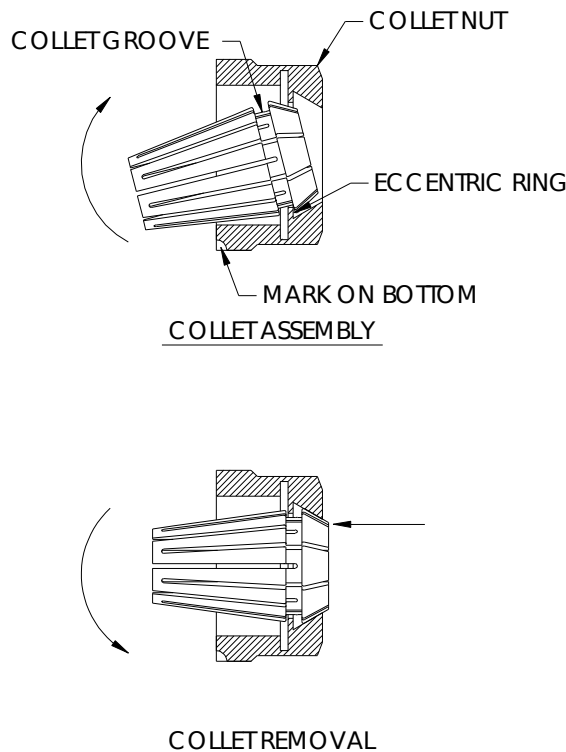

Figure 10. SM Collet Assembly and Removal

Improper assembly or removal of the Collet can permanently destroy the concentricity of the Collet and may also result in a damaged Collet Nut.

**NOTE: Only attach Collet Nuts with correctly assembled Collets, to the Motor Shaft! Never place the Collet into the Motor Shaft without first assembling the Collet into the Collet Nut.**

**NOTE: Never clamp oversized, or undersized, Toolholders! E.g., never use a  $\varnothing$ 11-12mm Collet to clamp a  $\varnothing$ 12.2mm Toolholder. Always use the corresponding Collet for the Toolholder being used.**

**NOTE: Insert the Toolholder the full length of the Collet for best results, if possible. However, never insert the Toolholder less than 2/3 of the Collet bore length. Improper tool insertion can permanently deform the Collet and will result in excessive run-out.**

### **3.5 Pneumatic Connection**

All STC versions of the 1503 require a dry, non-lubricated, filtered air supply, with a minimum pressure of 90 psi (6.2 bar) and a maximum pressure of 100 psi (6.9 bar). Failure to provide supply air to these specifications can degrade performance and will void any warranty repairs concerning pneumatic components. If the supply air pressure is too low then the unit will be unable to fully release the Toolholder. Exceeding the maximum air pressure could result in permanent damage to the STC.

The pneumatic supply system should be configured as shown in Figure 11. A manual or electrically operated valve may be used to energize the STC for Toolholder release, but the valve must exhaust **ALL** line pressure when unenergized. An electrically operated pneumatic valve is normally used in an automated workcell. PushCorp highly recommends the installation of a Pressure Switch in the Supply Line to the STC. This switch should not allow the unit to start if there is any pressure in the Supply Line. Pressure in the line will cause internal components to come into contact. This will either cause the motor not to spin, or cause very high internal forces, eventually friction welding components together.

Figure 11. Pneumatic Connections

The STC1503 and STC1503-BT30 are provided with 1/4 inch and 6 mm diameter tubing push-lock fittings for installation in the R 1/8 (Metric) Collet Unclamp Port

located on the top of the Clamping Housing (See Figure 13). Remove the shipping plug and install the desired size push-lock fitting. If another type of fitting is desired, unscrew the existing fitting and replace it with any fitting having an R 1/8 (Metric) thread. Be sure to use a thread seal product and do not over tighten the fitting.

The Unclamp Supply Line to the device should be 1/4 inch or 6 mm diameter flexible polyurethane tubing. The tubing should be routed to the device such that there are no kinks and that there is plenty of slack to allow for manipulator motion. Before inserting the tubing into the STC air fitting, open the Shut-Off Valve to blow out any contaminants which may be in the Unclamp Supply Line. The tubing can now be pushed into the self-locking fitting located on the Clamping Housing as shown in Figure 13. Charge the Unclamp Supply Line with compressed air and verify that there are no air leaks and that there is a minimum of 90 PSI (6.2 bar) at the STC. If a minimum air pressure cannot be achieved, then an auxiliary air compressor or booster pump must be installed.

**NOTE: PushCorp highly recommends the use of flexible polyurethane tubing as opposed to nylon tubing. This is because nylon tubing tends to crimp shut when it is bent.**

To remove the Unclamp Supply Line for service, make sure the air pressure is discharged, then while pushing inward on the fitting's plastic ring, simultaneously pull the tubing out. Cover or plug the self-locking fitting any time the Unclamp Supply Line is not connected. This will keep contaminants from entering.

**3.6 Electrical Connections**

The 1503 servo motor has two electrical connections, the Motor Power and Motor Feedback (See Figure 13). If PushCorp supplies the cables and amplifier the tool should be easily connected to the amplifier. If the customer wishes to use their own cables and/or amplifier the pin-outs for the Motor Power and Motor Feedback connectors are shown below in Figure 12. The Collet release mechanism of the 1503 Series relies solely on air pressure to operate; it requires no electrical connections.

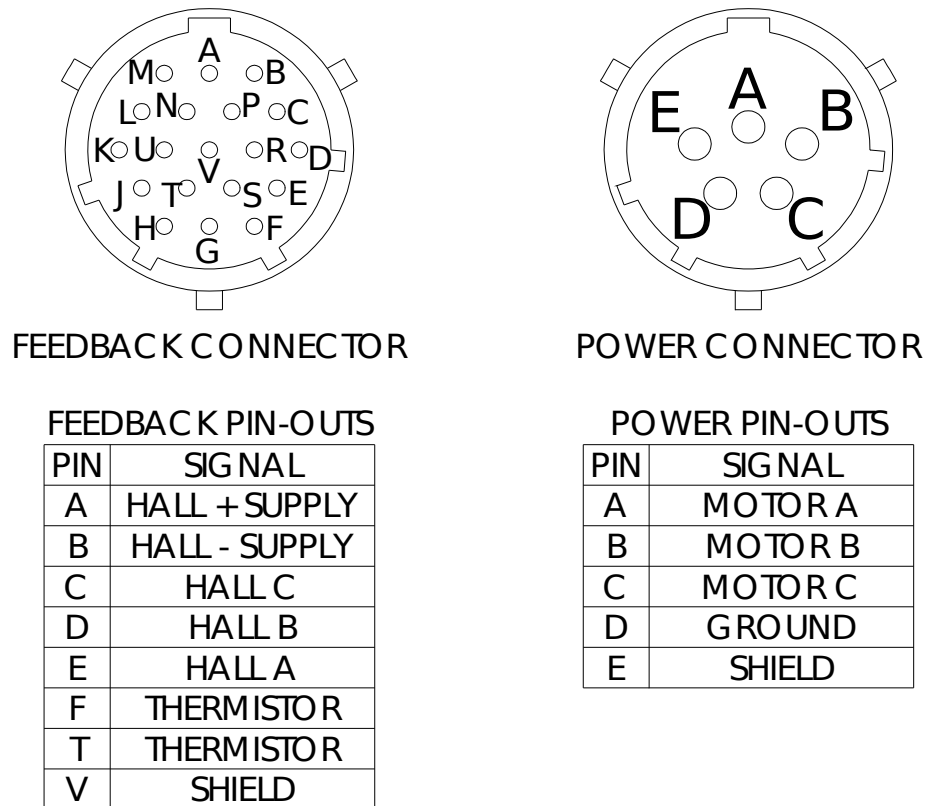

Figure 12. Electrical Connector Pin-outs

**CAUTION:** Do not run the Motor Power Cable in close proximity to any feedback or control cables because of possible electrical noise problems.



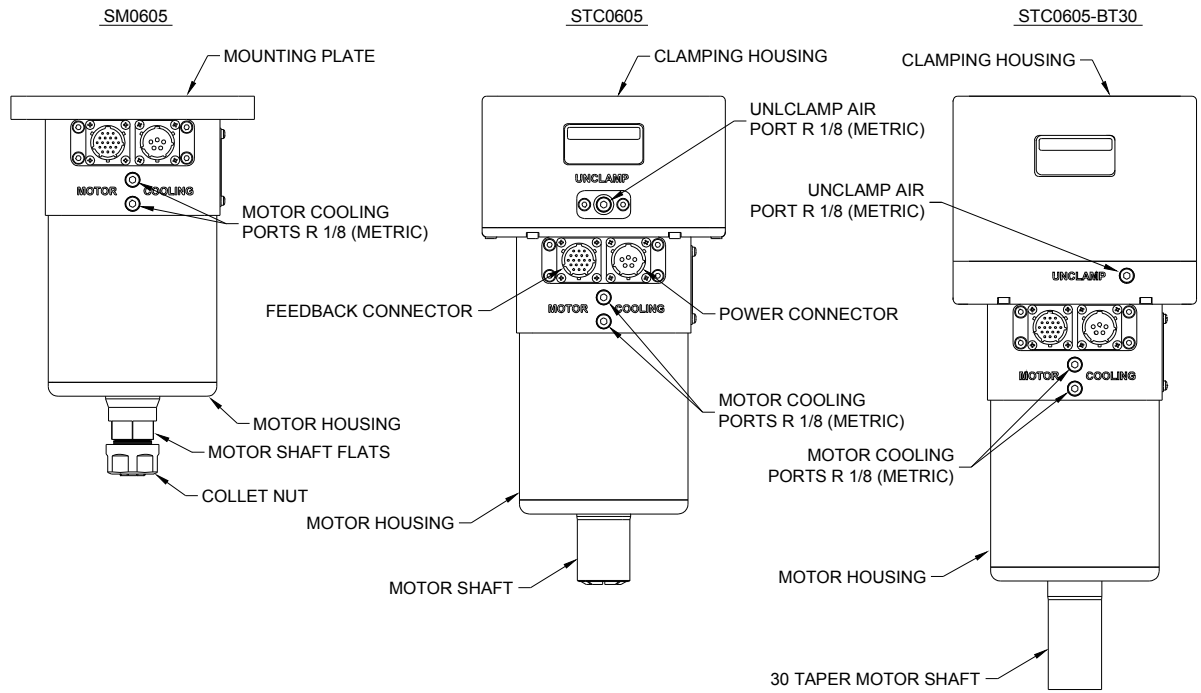

Figure 13. 1503 External Features

### 3.7 Motor Cooling

The 1503 Series has a compact, high speed, 3.0 Hp (2.2 kW) Servo Motor which requires water cooling. The motor is designed to operate below a temperature of 176 °F (80 °C). The optimal motor temperature range is 122 – 140 °F (50 – 60 °C). The 1503 contains cooling channels in the Motor Housing surrounding the motor stator. These channels allow efficient removal of the heat. The coolant enters and exits the Motor Housing through two Motor Cooling Ports as shown in Figure 13. Either of these Motor Cooling Ports can be used as an input, the other would then become an output

A closed-loop water cooling system must be used and requires a separate cooling unit that circulates water through the Motor Housing to remove the heat. All of the coolant is recirculated in the system, and no continuous supply or discharge is required. A mixture of pure distilled water and a corrosion inhibitor is required such as DowTherm SR-1, or equivalent. Typical cooling units are comprised of a pump, water to air heat exchanger, and fan. These units are commercially available from several manufacturers (eg Miller Coolmate 3, [www.millerwelds.com](http://www.millerwelds.com)). The cooling unit should be sized based on the motor power output of 3.0 hp (2.2 kW) with an overall motor efficiency of 90% and the motor load conditions. Again it is recommended to constantly monitor the motor temperature during operation to ensure that it does not overheat.

**NOTE: The life of the 1503 motor is directly related to the operational temperature, so proper cooling is critical.**

The 1503 Series is supplied with two 1/4" and 6 mm diameter tube push-lock fittings for installation in the Motor Cooling Ports. Remove the shipping plugs and install the desired size push-lock fittings. If another type of fitting is needed, replace the existing fitting with a fitting having an R 1/8 (Metric) thread. Be sure to use a thread seal product and do not over tighten the fitting.

### 3.8 Monitoring Motor Temperature

As previously stated, the 1503 Series is designed to operate below a temperature of 176 °F (80 °C) and within an optimal range of 122-140 °F (50-60 °C). In many situations it is desirable to monitor the internal motor temperature to ensure that the maximum temperature rating is not exceeded, and that the optimal temperature range is maintained. To facilitate this, the 1503 Series has a thermistor that is embedded in the motor windings. The thermistor connection is provided on the Motor Feedback Connector as shown in Figure 12. The thermistor temperature signal is a logarithmic function of the output resistance. The graph shown in Figure 14 illustrates the internal motor temperature verses the thermistor output resistance. In the graph, a temperature of 176 °F (80 °C) corresponds to a resistance of 2000 ohms. If the thermistor indicates a resistance of less than 2000 ohms then the motor should be immediately shut down before thermal damage occurs.

The motor also contains a thermal cutoff switch. If the temperature exceeds 212 °F (100 °C) the motor will stop running until it has cooled off. This feature should not be used to control the motor temperature. The thermal cutoff is designed to operate only when all other precautions have failed.

**STC1503 Thermistor Temp vs Resistance Characteristics**

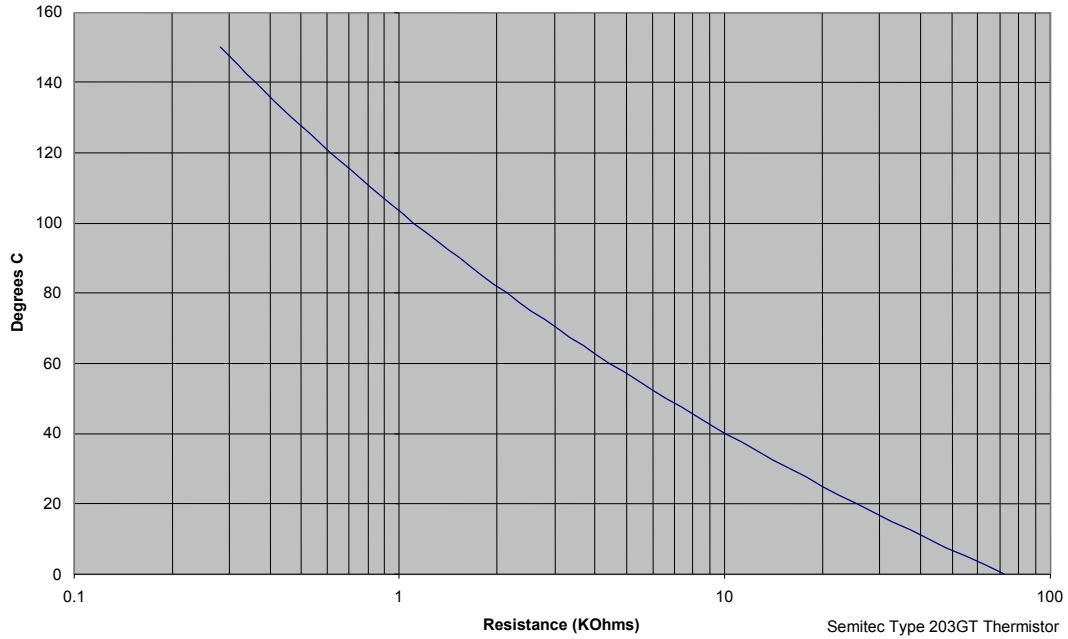

Figure 14. Thermistor Chart

The following equation can be used to calculate the motor temperature based on the measured thermistor resistance:

$$T = \frac{1}{2.656 \times 10^{-3} + 2.317 \times 10^{-4} \ln(R) + 1.752 \times 10^{-7} \ln(R)^3} - 273.15$$

$R$  is resistance in Kohms

$\ln()$  is the natural logarithm function (Base  $e$ )

$T$  is temperature in °C

### **3.9 Motor Acceleration/Deceleration**

Servo Motors have the ability to start and stop very quickly. As long as the motor does not overheat or the amplifier exceed the allowable current input, the motor will continue to operate. The problem is that the motor and amplifier can experience excessive current spikes with rapid acceleration and deceleration. Media or tooling with a large mass or large diameter (i.e., high moment of inertia) only increases the current surge. The amount of time allowed to reach the desired speed or stop will directly effect the life of the motor. PushCorp recommends a smooth, linear velocity ramp with a *minimum* period of one second be used to accelerate to full speed or to decelerate to zero speed. The minimum one-second-acceleration period must be increased if larger, higher inertia tools are used to prevent servo amplifier faults and avoid long-term damage.

## 4.0 Technical Specifications

### MOTOR SPECIFICATIONS:

- Power: 3.0 hp (2.2 kW)
- Continuous Stall Torque: 2.57 lb.-ft. (3.5 N·m)
- Minimum Speed: 60 RPM
- Maximum Speed: 15000 RPM
- Speed Regulation: 5% (Reversible)
- Shaft Maximum Axial Load: 150 lb. (666 N)
- Shaft Maximum Radial Load: 300 lb. (1332 N)
- Weight:
  - SM1503 - 12 lb (5.4 kg)
  - STC1503 – 23 lb. (10.4 kg)
  - STC1503-BT30 – 28 lb. (12.7 kg)
- Operating Temperature: Optimal: 122 – 140 °F (50 – 60 °C)  
Maximum: 176 °F (80 °C)
- Thermal Cutoff: 212 °F (100 °C)
- Max. Coolant Pressure: 60 psi (4.1 Bar)

### COLLET SPECIFICATIONS:

- Holding Torque:
  - SM1503 - 10 lb.-ft. (20.3 N·m) minimum
  - STC1503 – 10 lb.-ft. (20.3 N·m) minimum
  - STC1503-BT30 – N/A
- Toolholder:
  - SM1503 – Ø0.5 inch (12.7mm) standard
  - STC1503 – Ø.500±.001 inch (12.7mm)
  - STC1503-BT30 – BT30 toolholder
- Clamping Supply Air:
  - Dry, Non-lubricated, 90 psi (6.2 bar) Min., 100 psi (6.9 bar) Max.
  - Requires power amplifier and cables.
  - For specific dimensions see [www.pushcorp.com](http://www.pushcorp.com) for detail drawings.

*Specifications subject to change without notice.*

Fastener Tightening Torque Specs					
Fastener Size	Torque			Minimum Depth	
	in.-lbs.	ft.-lbs.	N·m	in.	mm
M4 x .7	50	4.2	5.6	0.17	4.3
M5 x .8	85	7.1	9.6	0.21	5.3
M6 x 1	140	11.7	15.8	0.25	6.3
M8 x 1.25	348	29.0	39.3	0.33	8.4
M10 x 1.5	600	50.0	67.8	0.41	10.5