

Pressure Control for Research and Industry

Digital Vacuum Regulator

User's Manual

Model 200

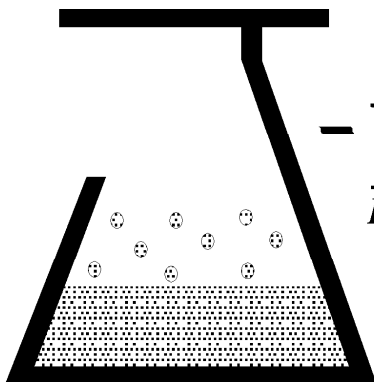

- KEM Scientific, Inc.
Instruments for Science from Scientists

INDEX

<u>SECTION</u>	<u>PAGE</u>
1. QUICK OPERATING INSTRUCTIONS	3
KEM-NET DATA LOGGING AND CONTROL SOFTWARE.	4
2. REGULATOR DESCRIPTION	5
3. OPERATIONS GUIDE	6
3.1 How the Regulator Works	6
3.2 Factors Affecting Vacuum Regulation Accuracy	6
3.3 Ramp-to-Setpoint & Soak Feature	7
3.4 Use with Rotary Evaporators	9
3.5 Vacuum Requirements	9
3.6 Changing the Display Resolution	10
3.7 Using the Regulator for Vacuum Distillations	10
3.8 Correcting Offset in the Displayed Pressure	11

Warranty

J-KEM Scientific, Inc. warrants this unit to be free of defects in materials and workmanship and to give satisfactory service for a period of 6 months from date of purchase. If the unit should malfunction, it must be returned to the factory for evaluation. If the unit is found to be defective upon examination by J-KEM, it will be repaired or replaced at no charge. However, this WARRANTY is VOID if the unit shows evidence of having been tampered with or shows evidence of being damaged as a result of excessive vibration, corrosive materials, or misuse. Components which wear or are damaged by misuse are not warranted. This includes valves and fuses.

THERE ARE NO WARRANTIES EXCEPT AS STATED HEREIN. THERE ARE NO OTHER WARRANTIES, EXPRESSED OR IMPLIED, INCLUDING BUT NOT LIMITED TO THE IMPLIED WARRANTIES OF MERCHANTABILITY AND OF FITNESS FOR A PARTICULAR PURPOSE. IN NO EVENT SHALL J-KEM SCIENTIFIC, INC. BE LIABLE FOR CONSEQUENTIAL, INCIDENTAL OR SPECIAL DAMAGES. THE BUYER'S SOLE REMEDY FOR ANY BREACH OF THIS AGREEMENT BY J-KEM SCIENTIFIC, INC. OR ANY BREACH OF ANY WARRANTY BY J-KEM SCIENTIFIC, INC. SHALL NOT EXCEED THE PURCHASE PRICE PAID BY THE PURCHASER TO J-KEM SCIENTIFIC, INC. FOR THE UNIT OR UNITS OF EQUIPMENT DIRECTLY AFFECTED BY SUCH BREACH.

Returns, requests for service and inquires should be directed to:

J-KEM Scientific, Inc.
6970 Olive Blvd.
St. Louis, MO 63130
(314) 863-5536
Fax: (314) 863-6070
Internet Catalog: <http://www.jkem.com>
E-mail: jkem911@jkem.com

Section 1 Quick Operating Instructions

1. Connect the Regulator to the Equipment

Connect the vacuum pump (or the vacuum source) to the tube marked “**Inlet**”. Note: When the Digital Vacuum Regulator (DVR) is used on equipment smaller than a Rotovap, a needle valve is needed for accurate regulation of pressure. Place the valve on the inlet port (see Section 3.2).

Connect the instrument in which the vacuum is to be regulated (i.e., rotary evaporator, distillation setup, etc.) to the tube marked “**Outlet**”. There should be no restrictions (i.e. valves, stopcocks) between the Outlet port and the equipment you’re regulating. Best results are obtained when large diameter tubing is used to make this connection.

2. Turn the Regulator On

1. Set the regulator selection switch to the **Off** position.
2. If the unit is fit with a needle valve, turn the valve until it’s fully closed.
3. Turn the regulator and vacuum pump on.

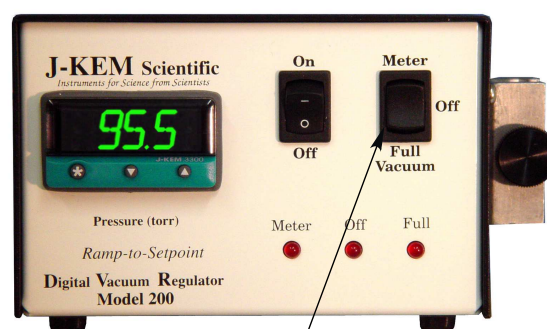

Regulator Selection Switch

3. Enter the Desired Pressure.

The default display of the meter is the pressure in the equipment it’s attached to. The desired pressure (or set point) is entered by holding in the “*” button on the front of the meter and simultaneously pressing either the “↓” button to decrease or the “↑” button to increase the set point. The set point, which appears as a blinking number, can be seen at any time by holding in the “*” button.

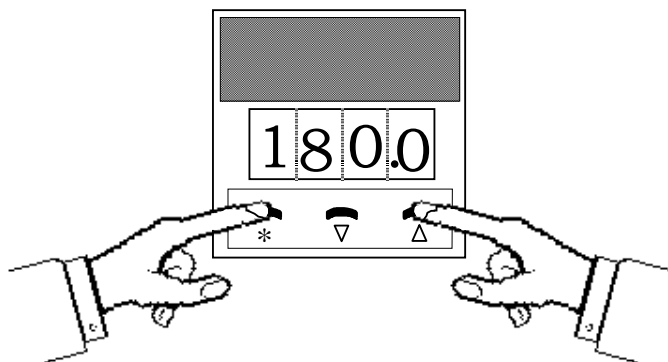

4. **Move the Regulator Selection Switch to the METER Position.** When set to the Meter position, the regulator maintains the attached equipment at the set point pressure entered in step 3.
5. **For Controllers Equipped with Needle Valves,** open the valve until the equipment is evacuated at a *reasonable* rate. When at the set point, adjust the valve for stable pressure regulation. Leave the needle valve in this position for future use. Once the valve is set for a *reasonable* evacuation rate it doesn’t require further adjustment.

KEM-Net Data Logging and Control Software

The USB port on the back panel of the controller is an interface to J-KEM's KEM-Net Software. KEM-Net is free and can be downloaded from J-KEM's web site at www.jkem.com.

	<p>KEM-Net provides remote control of up to 8 controllers, graphical presentations of each digital meter and time & pressure plots. Highlights of KEM-Net include:</p> <ul style="list-style-type: none">* GLP and GMP compliant data logging* Runs a 12 step pressure ramp* Logging of Time and pressure* Logging of % Power for Exo and Endotherm detection* Program KEM-IO Actions (Section 3.10)* Over- & Under-pressure alarm functions.
---	--

KEM-Net also includes a virtual comm port driver that provides a simple ASCII interface to operate and data log the controller from LabView or other software packages.

New Features:

GMP compliant data logging
Exo and Endotherm monitoring

KEM-IO Remote Control of Laboratory Equipment based on Time and Pressure

KEM-IO is an optional feature that allows the controller to respond to inputs from instruments, like a vacuum sensor or a hood door switch, and also to control instruments, like stirrers, valves and chillers based on system pressure. KEM-IO automates programs as simple as:

Regulate at 500 torr while waiting for an external signal. When the signal is present, then turn on my peristaltic pump to add reagents.

or as sophisticated as:

Open this valve, then ramp my reaction pressure from 500 to 100 torr if 45 minutes, hold for 2 hours, then turn off regulation.

Contact J-KEM for additional information.

Section 2 Regulator Description

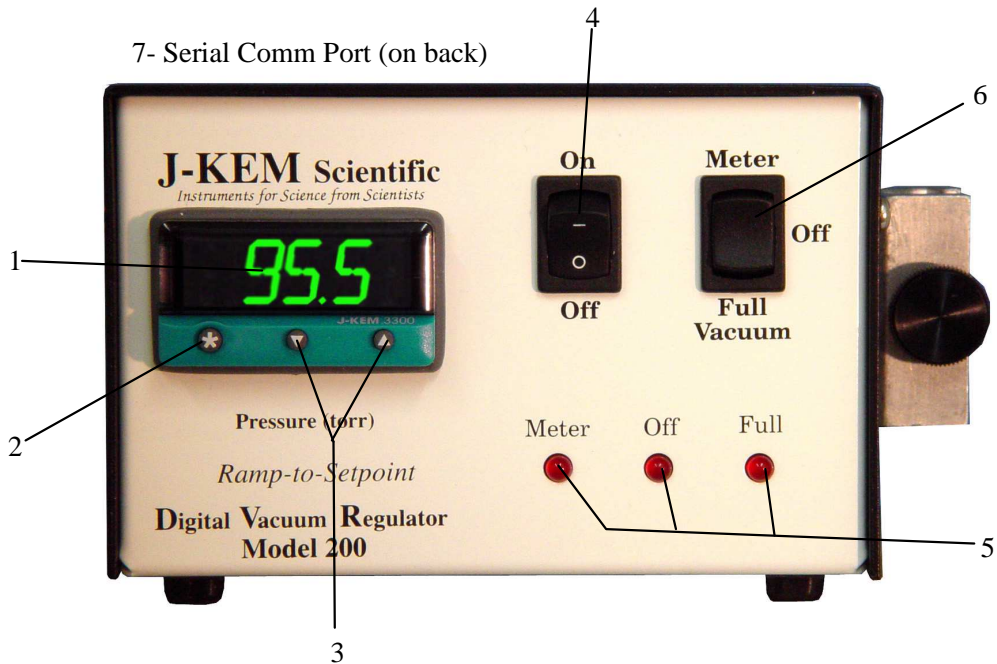

1. Pressure Display. The default display is the pressure in the attached piece of equipment in units of mm of Hg (torr). The set point pressure can be seen any time by holding in the “*” button.
2. Control Key. Pressing (and holding) this button causes the regulator to display the set point pressure as a blinking number in the display. The set point pressure is entered by holding in the control key and simultaneously pressing the “↑” button to increase or the “↓” button to decrease the displayed value.
3. Decreases (▼) or increases (▲) the set point pressure when the “*” button is simultaneously held in.
4. Regulators Power Switch.
5. Indicates the position of the regulator selection switch (#6).
6. Regulator Selection Switch. A three position switch that determines the pressure in the attached equipment (see Section 3.6). The different switch positions have the following effects:
 - Meter:** Evacuates the attached equipment to the set point pressure entered in the controller.
 - Off:** Isolates the vacuum pump from the attached equipment. In this position the equipment can be opened to the atmosphere while the vacuum pump is running.
 - Full Vacuum:** Opens the regulator continuously to the vacuum pump (independent of set point pressure). The pressure in the attached equipment is lowered to the limit achievable by the vacuum pump.
7. Optional serial port for remote PC control and data acquisition.

Warning: J-KEM’s Model 200 Digital Vacuum Regulator should only be used with vacuums. It is not designed to regulate pressures above atmospheric pressure. Exposure to pressures above atmospheric pressure may result in damage to the regulator.

Section 3 Operations Guide

3.1 How the Regulator Works

The vacuum regulator consists of 3 important pieces. The **pressure transducer** measures the pressure in the piece of equipment being regulated. The **process controller** compares the pressure reading from the transducer with the set point pressure (i.e. the desired pressure) entered. If the pressure in the equipment is greater than the set point, the process controller opens the **control valve** allowing the vacuum pump to decrease the pressure in the equipment. When the pressure in the equipment equals the set point pressure, the process controller shuts the control valve preventing the vacuum pump from lowering the pressure any further. The basic method of operation is very simple. When the pressure in the equipment is above the set point the controller opens the control valve connecting the equipment to the vacuum pump, and when the equipment is at or below the set point, the controller shuts the control valve, isolating the vacuum pump from the equipment.

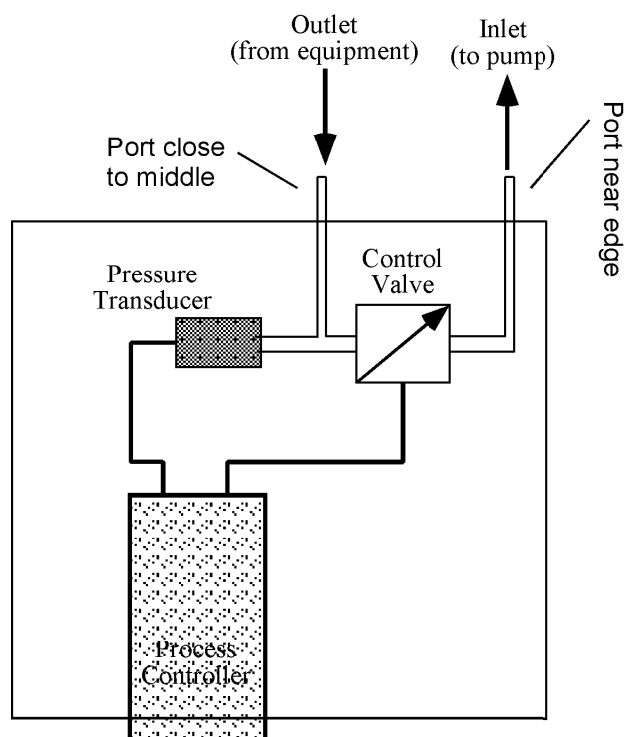

3.2 Factors Affecting Vacuum Regulation Accuracy

- a. **The rate of evacuation.** An important factor affecting stability is the **rate** the vacuum pump evacuates the attached equipment. In some cases the rate of evacuation must be manually limited by using a needle valve. A needle valve is used because many vacuum pumps have such high pumping capacities that they evacuate equipment faster than the controller can respond to changes in pressure (the controller needs $1/10^{th}$ of a second to respond to pressure changes). Particularly in small equipment, pressure can be lower more than desired in $1/10^{th}$ of a second without a needle valve limiting the evacuation rate. Regulating the evacuation rate becomes more important the smaller the piece of equipment being evacuated since it's evacuated faster (for example consider a 50 ml flask compared to a rotary evaporator). The diagram at the right shows the result of using a needle valve to limit evacuation rate.

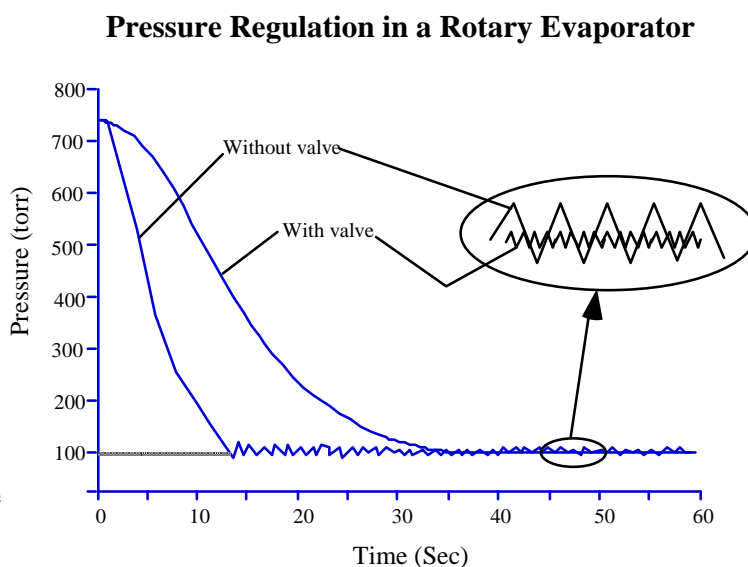

- b. **Use a cold trap to condense volatile solvents.** At least one dry ice trap should be placed between the OUTLET of the digital vacuum regulator and the equipment being regulated. This prolongs the life of both the regulator and the vacuum pump. The dry ice trap available from J-KEM (catalog # RCE1000) is highly recommended because of its high condensation efficiency, large reservoir and ease of solvent removal.

3.3 Ramp-to-Setpoint & Soak Feature. A new feature of J-KEM's controllers called 'Ramp-To-Setpoint' allows a specific rate for evacuation to be entered (e.g., reduce the pressure to 20 torr at a rate of 10 torr/Hour). A second feature called 'Soak' then lets you specify how long to stay at that pressure before turning off.

Example of Program Ramps

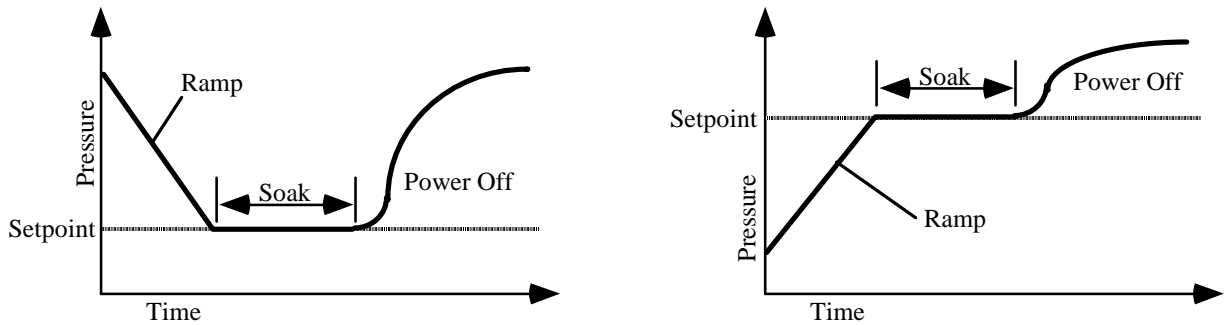

The controller is shipped with the Ramp-to-Setpoint feature OFF, the user must specifically turn Ramp-to-Setpoint ON. When Ramp-to-Setpoint is OFF, the controller evacuates to the entered setpoint at the fastest rate possible (i.e., the rate that results from fully opening the vacuum valve). When Ramp-to-Setpoint is ON, the controller evacuates at the user entered ramp rate. The Ramp-to-Setpoint feature and its associated parameters are turned on and set in the controller's programming mode. The parameters of importance are:

SPrr SetPoint Ramp Rate. Allowable Values: 0 to 9990 torr/Hr.

This specifies the desired evacuation rate. Note, this parameter specifies the *desired* rate of evacuation. Extremely high evacuation rates will not be maintained if the rate exceeds the capacity of the vacuum pump. To minimize fluctuations around the setpoint a needle valve may be needed between the Digital Vacuum Regulator and the vacuum pump.

SPrn SetPoint Ramp Run. Allowable Values: ON, OFF, Hold

This parameter turns the ramping feature ON or OFF. During an active run, if this parameter is set to 'Hold', the setpoint ramp stops and *holds* at its current value. This continues until the parameter is set to ON or OFF. When set to OFF, the values in SetPoint Ramp Rate and Soak Time are ignored.

SOAK Soak Time. Allowable Values: "- -", 0 to 1440 min.

This specifies the amount of time to *soak* at the setpoint after the setpoint vacuum ramp is complete. A setting of "- -" causes the controller to remain at the final setpoint indefinitely. A numeric value causes the controller to stay at the setpoint for the entered time and then turn power off to the vacuum valve. The pressure in the vessel will increase depending on the number of leaks in the system.

Important Points to Know

1. While the Ramp-to-Setpoint feature is activated, the display alternates between the current reaction pressure and the word “**SPr**” to indicate that a “SetPoint Ramp” is active.
2. Once the Ramp-to-Setpoint feature is activated in programming mode, it will remain active until it’s deactivated in programming mode. Ramp-to-Setpoint feature remains active even if power is turned off to the controller.

Activating & Programming the Ramp-to-Setpoint Feature

1.	Press and hold in both the ↑ and ↓ keys on the front of the meter until the word “ tunE ” appears in the display, then release both keys.
2.	Press the ↑ key (8 times) until the word “ SPrr ” appears in the display. This is where you set the ramp rate in units of torr/hour. First hold in the ‘*’ key, then while holding in the ‘*’ key press the ↑ or ↓ key until the desired ramp rate appears in the display, then let go of all the keys. Units are in torr/hour, (i.e., mmHg/hour).
3.	Press the ↑ key once and the word “ SPrn ” will appear in the display. This function turns the ramping feature ON, OFF, or to Hold. First hold in the ‘*’ key, then while holding in the ‘*’ key press the ↑ or ↓ key until the desired setting appears in the display, then let go of all the keys.
4.	Press the ↑ key once and the word “ Soak ” will appear in the display. This is where the soak time is set in units of Minutes. A soak time of ‘--’ means to ‘soak forever’ (this setting is one below ‘0’). First hold in the ‘*’ key, then while holding in the ‘*’ key press the ↑ or ↓ key until the desired time appears in the display, then let go of all the keys. If a soak time is set, the controller display will alternate between showing the current reactor pressure and the word “ StoP ” when the soak time has expired to indicate that power has been turned off.
5.	To exit programming mode, press and hold in both the ↑ and ↓ keys until the pressure appears in the display, and release both keys.

Deactivating the Ramp-to-Setpoint Feature

1.	Press and hold in both the ↑ and ↓ keys on the front of the meter until the word “ tunE ” appears in the display, then release both keys.
2.	Press the ↑ key (9 times) until the word “ SPrn ” appears in the display. This function turns the ramping feature ON and OFF. First hold in the ‘*’ key, then while holding in the ‘*’ key press the ↑ or ↓ key until OFF appears in the display, then let go of all the keys.
3.	To exit programming mode, press and hold in both the ↑ and ↓ keys until the pressure appears in the display, and release both keys.

3.4 Use with Rotary Evaporators. Your vacuum regulator is ideally suited for use with rotary evaporators. To demonstrate the simplicity of the regulator, the following example is given.

1. Set the Regulator Selection Switch (6) to the 'OFF' position and then turn on power to the DVR. Turn on the vacuum pump.
2. Enter a set point into the regulator appropriate for the solvent being removed, for example, 300 torr for CH₂Cl₂.
3. Place the flask on the rotovap and move the regulator switch from the OFF to the METER position. When in the OFF position, the regulator isolates the rotovap from the vacuum pump so the rotovap can be open to the atmosphere while the pump is running. When placed in the METER position, the regulator evacuates the rotovap to the pressure entered into the meter.
4. When the majority of the solvent is removed, move the regulator switch from the METER to the FULL VACUUM position. When in the FULL VACUUM position the regulator ignores the set point pressure and fully evacuates the rotovap removing the last amount of solvent.
5. When all the solvent is removed place the regulator switch to the OFF position and remove the flask. Place the next flask on the rotovap and move the regulator switch to the METER position to begin the process again.

For the entire rotary evaporation process the only action needed is to change the position of the regulator switch. The pump can run continuously and there's no need to change the set point pressure. Solvent recoveries from a typical rotary evaporator are shown in the table below.

Solvent Recovery from Rotary Evaporators using J-KEM's Digital Vacuum Regulator

Regulator Set Point	Solvent	Bath Temperature (° C)	Weight of Solvent Placed on Rotary Evaporator	Weight of Solvent Recovered from Rotary Evaporator	Percent Solvent Recovered	Time To Evaporate Flask to Dryness
475 torr	Ether	30	239.68 g (338.5 ml)	238.66 g	99.6%	14.6 min.
400 torr	CH ₂ Cl ₂	30	466.68 g (352.2 ml)	465.32 g	99.7%	43.1 min.
300 torr	CH ₂ Cl ₂	30	476.38 g (359.5 ml)	474.88 g	99.7%	22.5 min.
300 torr	CH ₂ Cl ₂	30	471.19 g (355.6 ml)	470.35 g	99.8%	21.9 min.
300 torr	CH ₂ Cl ₂	30	467.79 g (353.0 ml)	465.72 g	99.8%	22.4 min.
100 torr	CH ₂ Cl ₂	30	338.23 g (255.3 ml)	336.42 g	99.5%	5.9 min.
90 torr	EtOAc	35	285.41 g (316.4 ml)	284.99 g	99.9%	17.0 min.
50 torr	Toluene	50	236.42 g (272.7 ml)	234.91 g	99.4%	15.7 min.

Test Conditions: Buchi RE 111 evaporator equipped with a dry ice condenser.
 Vacuum pump ultimate pressure = 0.01 torr.
 All tests were conducted using a 500 ml round bottomed flask at the pressure shown.

3.5 Vacuum Requirements. The type of vacuum source (i.e. a high vacuum pump, aspirator, or in-house vacuum system) has no affect on the regulators operation or performance. The only requirement is that the vacuum source be lower in pressure than the pressure you want to regulate the equipment at. That is, to achieve a vacuum or 40 torr in the attached equipment the vacuum source must be at least 40 torr. The Digital Vacuum Regulator doesn't create a vacuum it only regulates the vacuum from an external vacuum source.

3.6 Changing the Display Resolution. The procedure below allows you to select the pressure display resolution of your J-KEM vacuum controller. This procedure allows you to specify 0.1 or 1 torr resolution.

1.	Press and hold in both the ↓ and ↑ keys on the front of the digital meter until the word “tunE” appears in the display, then release both keys.
2.	Press the ↓ key until “LEVL” appears in the display. Next, hold in the ‘*’ key, then while holding in the ‘*’ key press the ↑ key until “3” appears in the display. Let go of all the keys.
3.	Press the ↑ key 11 times until “vEr” appears in the display. Next, hold in both the ↓ and ↑ keys for about 10 seconds until the display changes (what the display changes to can be variable, so just hold in the button until vEr goes away). Press the ↑ or ↓ key until “LoCk” appears in the display. While holding in the ‘*’ key, press the ↑ or ↓ key until ‘NonE’ appears in the display. Let go of all the keys.
4.	Press the ↓ key until “LEVL” appears in the display. Next, hold in the ‘*’ key, then while holding in the ‘*’ key press the ↓ key until “2” appears in the display. Let go of all the keys.
5.	Press the ↑ key 7 times until “diSP” appears in the display. Next, hold in the ‘*’ key, then while holding in the ‘*’ key press the ↓ or ↑ keys until “1”, to select 1 torr resolution, or “0.1”, to select 0.1 torr resolution, appears in the display. Let go of all the keys.
6.	Press and hold in both the ↓ and ↑ keys until the pressure appears in the display, then release both keys. Pressure is now displayed in the selected units.

3.7 Using the Regulator for Vacuum Distillations. This model of J-KEM’s vacuum regulator is intended for medium accuracy vacuum applications, such as rotary evaporators and vacuum ovens. The DVR-200 regulates pressure with stability (pressure variations) from ± 0.5 to ± 2 torr (as opposed to our high accuracy, DVR-1000, regulator that controls variations to better than ± 0.1 torr). Some vacuum distillations are not substantially affected by changes in pressure of ± 0.5 torr, but many are. **This regulator is not recommended for small, laboratory scale vacuum distillations.** J-KEM does make a precision vacuum regulator, the DVR-1000, which is designed and recommended for vacuum distillations. Having said that the DVR-200 is not recommended for vacuum distillations, we at J-KEM suspect you may try it anyway, so let us help you set the distillation up to deliver the best performance possible.

Points to follow:

1. Connect a precision needle valve (available from J-KEM) between the vacuum pump and the vacuum regulator.
2. Use a cold trap between the distillation set up and the vacuum regulator.
3. Close the needle valve all the way. Turn on the vacuum pump, set the desired vacuum setpoint in the DVR-200 and position the vacuum switch to the Meter position.
4. Open the needle valve until the pressure in the flask decreases at a slow, controlled rate that seems appropriate to the volume of the flask in use.
5. Once at the desired setpoint, adjust the position of the valve until pressure fluctuations are within an acceptable range for your distillation.
6. The vacuum transducer in the DVR-200 loses some linearity below 12 torr. The pressure reading will be consistent and reproducible, but its absolute value may be off by as much as 2 torr.

3.8 Correcting Offset in the Displayed Pressure. A small amount of error can develop in the displayed pressure (≈ 2 torr) of the vacuum regulator. This is due to the wide pressure range of the transducer used and accuracy better than this is usually not possible. For display errors larger than 2mm, the controller can be calibrated using the procedure below (For users experienced with J-KEM's meter, do not correct pressure using the "Zero" function. This introduces an error, not a correction). Before beginning this procedure you will need to know the correct barometric pressure inside your lab.

This procedure should only be performed by a qualified electrician.

1. Remove the controller's cover.
2. Plug the OUTLET port of the regulator and set the regulator selection switch to the FULL VACUUM position.
3. Let the controller warm up for 30 minutes.
4. Connect a vacuum pump to the INLET port, turn it on and let it evacuate the controller to as close to 0 torr as possible. Measure the pressure in the system using a manometer. The regulator must be evacuated to as close to 0 torr as possible before the adjustment in step 5 is performed.
5. Adjust the "Zero" pot until the reading on the meter matches the actual pressure.
6. Turn the vacuum pump off and unplug the OUTLET port. Adjust the "Span" pot until the meter reads the actual barometric pressure in the lab.
7. Turn the controller off and replace the cover.

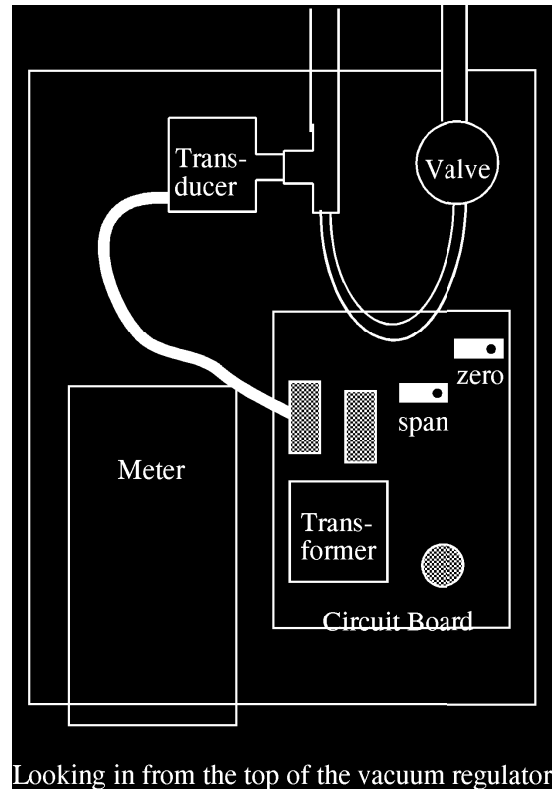

Looking in from the top of the vacuum regulator

III. Resetting the Controller to Original Factory Settings

J-KEM manufactures the most technically advanced vacuum regulator available and should give you consistently flawless control. If you have difficulty with your controller, a good place to start to correct the problem is by loading the original factory settings. If you still have difficulty with your controller, our Engineering department will help you resolve the problem.

1.	Press and hold in both the ↓ and ↑ keys on the front of the digital meter until the word “tunE” appears in the display, then release both keys.
2.	Press the ↓ key until “LEVL” appears in the display. Next, hold in the ‘*’ key, then while holding in the ‘*’ key press the ↑ key until “3” appears in the display. Let go of all the keys.
3.	Press the ↑ key until “rSEt” appears in the display. Next, hold in the ‘*’ key, then while holding in the ‘*’ key press the ↑ key until the word “All” appears in the display. Let go of all the keys. This will clear the controller’s memory and cause programming mode to exit.
4.	Press and hold in both the ↓ and ↑ keys until the word “inPt” appears in the display, then release both keys. First hold in the ‘*’ key, then while holding in the ‘*’ key press the ↑ key until the value “Lin3” appears in the display. Let go of all the keys.
5.	Press the ↑ key once and “unit” will appear in the display. Next, hold in the ‘*’ key, then while holding in the ‘*’ key press the ↑ key until the value “SEt” appears in the display. Let go of all the keys.
6.	Press the ↑ key once and the word “SP1.d” appears in the display. Next, hold in the ‘*’ key, then while holding in the ‘*’ key press the ↑ key until the value “rLy” appears in the display. Let go of all the keys.
7.	Press in both the ↓ and ↑ keys until the pressure appears in the display (“PArk” also appears), then release both keys.
8.	Press and hold in both the ↓ and ↑ keys on the meter until the word “tunE” appears in the display, then release both keys.
9.	Press the ↑ key once and the word “bAnd” will appear in the display. Next, hold in the ‘*’ key, then while holding in the ‘*’ key press the ↓ key until the value “0.1” appears in the display. Let go of all the keys.
10.	Press the ↑ key once and the word “int.t” will appear in the display. Next, hold in the ‘*’ key, then while holding in the ‘*’ key press the ↑ key until the value “10” appears in the display. Let go of all the keys.
11.	Press the ↑ key once and the word “dEr.t” will appear in the display. Next, hold in the ‘*’ key, then while holding in the ‘*’ key press the ↑ key until the value “25” appears in the display. Let go of all the keys.
12.	Press the ↑ key once and the word “dAC” will appear in the display. Next, hold in the ‘*’ key, then while holding in the ‘*’ key press the ↑ key until the value “1.5” appears in the display. Let go of all the keys.
13.	Press the ↑ key once and the word “CyC.t” will appear in the display. Next, hold in the ‘*’ key, then while holding in the ‘*’ key press the ↓ key until the value “on.of” appears in the display. Let go of all the keys.
14.	Press the ↑ key until the word “SPm” appears in the display. Next, hold in the ‘*’ key, then while holding in the ‘*’ key press the ↓ or ↑ key until the word “OFF” is displayed. Let go of all the keys.
15.	Press the ↓ key until the word “LEVL” appears in the display.
16.	Hold in the ‘*’ key, then while holding in the ‘*’ key press the ↑ key until “2” appears in the display. Let go of all the keys.
17.	Press the ↑ key until “diSP” appears in the display. Next, hold in the ‘*’ key, then while holding in the ‘*’ key press the ↓ or ↑ key until the value “0.10” appears in the display. Let go of all the keys.
18.	Press the ↑ key until “hi.SC” appears. Next, hold in the ‘*’ key, then while holding in the ‘*’ key press the ↑ key until the number in the display reads 800. Let go of all the keys.
19.	Press the ↓ key until the word “LEVL” appears in the display.
20.	First hold in the ‘*’ key, then while holding in the ‘*’ key press the ↓ key until “C” appears in the display. Let go of all the keys.
21.	Press the ↑ key and “Addr” will appear in the display. Next, hold in the ‘*’ key, then while holding in the ‘*’ key press the ↓ or ↑ key until the value “1” appears in the display. Let go of all the keys.
22.	Press the ↑ key and “bAud” will appear in the display. Next, hold in the ‘*’ key, then while holding in the ‘*’ key press the ↓ or ↑ key until the value “9600” appears in the display. Let go of all the keys.
23.	Press the ↑ key and “dAtA” will appear in the display. Next, hold in the ‘*’ key, then while holding in the ‘*’ key press the ↓ or ↑ key until the value “18n1” appears in the display. Let go of all the keys.
24.	Press and hold in both the ↑ or ↓ keys until the pressure appears in the display, then release both keys. The word “PArk” in the display will go away when a set point is entered.