



CONTENTS

1. SAFETY INFORMATION.....	3
2. SAFETY INSTRUCTIONS.....	4
3. OPERATION.....	6
4. DAILY USE.....	8
5. CARE AND CLEANING.....	10
6. TROUBLESHOOTING.....	11
7. INSTALLATION.....	13
8. TECHNICAL INFORMATION.....	14

FOR PERFECT RESULTS

Thank you for choosing this AEG product. We have created it to give you impeccable performance for many years, with innovative technologies that help make life simpler features you might not find on ordinary appliances. Please spend a few minutes reading to get the very best from it.

Visit our website for:



Get usage advice, brochures, trouble shooter, service information:

www.aeg.com



Register your product for better service:

www.registeraeg.com



Buy Accessories, Consumables and Original spare parts for your appliance:

www.aeg.com/shop

CUSTOMER CARE AND SERVICE

Always use original spare parts.

When contacting our Authorised Service Centre, ensure that you have the following data available: Model, PNC, Serial Number.

The information can be found on the rating plate.

 Warning / Caution-Safety information

 General information and tips

 Environmental information

Subject to change without notice.

1. ⚠ SAFETY INFORMATION

Before the installation and use of the appliance, carefully read the supplied instructions. The manufacturer is not responsible if an incorrect installation and use causes injuries and damages. Always keep the instructions with the appliance for future reference.

1.1 Children and vulnerable people safety

- This appliance can be used by children aged from 8 years and above and persons with reduced physical, sensory or mental capabilities or lack of experience and knowledge if they have been given supervision or instruction concerning use of the appliance in a safe way and understand the hazards involved.
- Do not let children play with the appliance.
- Cleaning and user maintenance shall not be made by children without supervision.
- Keep all packaging away from children.

1.2 General Safety

- This appliance is intended to be used in household and similar applications such as:
 - Farm houses; staff kitchen areas in shops, offices and other working environments
 - By clients in hotels, motels, bed and breakfast and other residential type environments
- Keep ventilation openings, in the appliance enclosure or in the built-in structure, clear of obstruction.
- Do not use mechanical devices or other means to accelerate the defrosting process, other than those recommended by the manufacturer.
- Do not damage the refrigerant circuit.
- Do not use electrical appliances inside the food storage compartments of the appliance, unless they are of the type recommended by the manufacturer.

- Do not use water spray and steam to clean the appliance.
- Clean the appliance with a moist soft cloth. Only use neutral detergents. Do not use abrasive products, abrasive cleaning pads, solvents or metal objects.
- Do not store explosive substances such as aerosol cans with a flammable propellant in this appliance.
- If the supply cord is damaged, it must be replaced by the manufacturer, its service agent or similarly qualified persons in order to avoid a hazard.

2. SAFETY INSTRUCTIONS

2.1 Installation



WARNING!

Only a qualified person must install this appliance.

- Remove all the packaging.
- Do not install or use a damaged appliance.
- Obey the installation instruction supplied with the appliance.
- Always be careful when you move the appliance because it is heavy. Always wear safety gloves.
- Make sure the air can circulate around the appliance.
- Wait at least 4 hours before connecting the appliance to the power supply. This is to allow the oil to flow back in the compressor.
- Do not install the appliance close to radiators or cookers, oven or hobs.
- The rear of the appliance must stand against the wall.
- Do not install the appliance where there is direct sunlight.
- Do not install this appliance in areas that are too humid or too colds, such as the construction appendices, garages or wine cellars.
- When you move the appliance, lift it by the front edge to avoid scratching the floor.

2.2 Electrical connection



WARNING!

Risk of fire and electrical shock.

- The appliance must be earthed.
- All electrical connections should be made by a qualified electrician.
- Make sure that the electrical information on the rating plate agrees with the power supply. If not contact an electrician.
- Always use a correctly installed shockproof socket.
- Do not use multi-plug adapters and extension cables.
- Make sure not to cause damage to the electrical components (e.g. mains plug, mains cable, compressor). Contact the Service or an electrician to change the electrical components.
- The mains cable must stay below the level of the mains plug.
- Connect the mains plug to the mains socket only at the end of the installation. Make sure that there is access to the mains plug after the installation.
- Do not pull the mains cable to disconnect the appliance. Always pull the mains plug.

2.3 Use



WARNING!

Risk of injury, burns, electrical shock or fire.

- Do not change the specification of this appliance.
- Do not put electrical appliances (e.g. ice cream makers) in the appliance unless they are stated applicable by the manufacturer.
- Be careful not to cause damage to the refrigerant circuit. It contains isobutane (R600a), a natural gas with a high level of environmental compatibility. This gas is flammable.
- If damage occurs to the refrigerant circuit, make sure that there are no flames and sources of ignition in the room. Ventilate the room.
- Do not let hot items to touch the plastic parts of the appliance.
- Do not put soft drinks in the freezer compartment. This will create pressure on the drink container.
- Do not store flammable gas and liquid in the appliance.
- Do not put flammable products or items that are wet with flammable products in, near or on the appliance.
- Do not touch the compressor or the condenser. They are hot.
- Do not remove or touch items from the freezer compartment if your hands are wet or damp.
- Do not freeze again food that has been thawed.
- Obey the storage instructions on the packaging of frozen food.

2.4 Care and cleaning



WARNING!

Risk of injury or damage to the appliance.

- Before maintenance, deactivate the appliance and disconnect the mains plug from the mains socket.
- This appliance contains hydrocarbons in the cooling unit. Only a qualified person must do the maintenance and the recharging of the unit.
- Regularly examine the drain of the appliance and if necessary, clean it. If the drain is blocked, defrosted water collects in the bottom of the appliance.

2.5 Disposal



WARNING!

Risk of injury or suffocation.

- Disconnect the appliance from the mains supply.
- Cut off the mains cable and discard it.
- Remove the door to prevent children and pets to be closed inside of the appliance.
- The refrigerant circuit and the insulation materials of this appliance are ozone-friendly.
- The insulation foam contains flammable gas. Contact your municipal authority for information on how to discard the appliance correctly.
- Do not cause damage to the part of the cooling unit that is near the heat exchanger.

3. OPERATION

3.1 Control panel

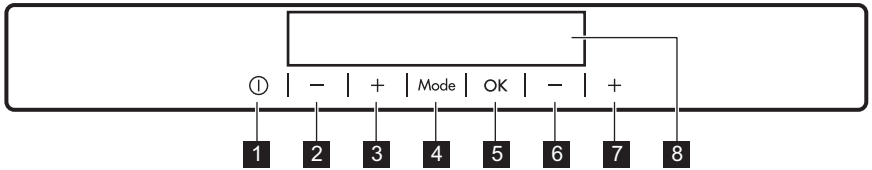

- 1** ON/OFF button
- 2** Top compartment temperature colder button
- 3** Top compartment temperature warmer button
- 4** Mode button
- 5** OK button
- 6** Bottom compartment temperature colder button
- 7** Bottom compartment temperature warmer button
- 8** Display

It is possible to change predefined sound of buttons by pressing together Mode button and Temperature colder button for some seconds. Change is reversible.

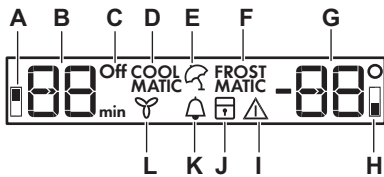

- A)** Fridge compartment indicator
- B)** Fridge temperature indicator and timer indicator
- C)** Fridge OFF indicator
- D)** COOLMATIC function
- E)** Holiday function
- F)** FROSTMATIC function
- G)** Freezer temperature indicator
- H)** Freezer compartment indicator
- I)** Alarm indicator
- J)** ChildLock function
- K)** MinuteMinder function
- L)** DYNAMICAIR function

3.2 Switching on

1. Connect the mains plug to the power socket.
2. Press the appliance ON/OFF if the display is off.

The alarm buzzer could operate after few seconds.

The temperature indicators show the set default temperature.

To reset the alarm refer to "High temperature alarm".

To select a different set temperature refer to "Temperature regulation".

If "dEMO" appears on the display, refer to "What to do if..." chapter.



If the door remains open for some minutes, the light will turn off automatically. The light is reset by closing and opening the door itself.

3.3 Switching off

1. Press the appliance ON/OFF button for a few seconds. The display switches off.
2. Disconnect the mains plug from the power socket.

3.4 Switching on the fridge

To switch on the fridge it is enough to press the fridge temperature regulator. To switch on the fridge in the other way:

1. Press Mode until the corresponding icon appears.
The Fridge OFF indicator flashes.
2. Press OK to confirm.
The fridge OFF indicator goes off.

 To select a different set temperature refer to "Temperature regulation".

3.5 Switching off the fridge

1. Press Mode until the corresponding icon appears.
The fridge OFF indicator and the fridge compartment indicator flash.
The fridge temperature indicator shows dashes.
2. Press OK to confirm.
The fridge OFF indicator is shown.

3.6 Temperature regulation

Set temperature of the fridge and of the freezer by pressing the temperature buttons.

Default temperatures:

- +5°C for the fridge
- -18°C for the freezer

The temperature indicators show the set temperature.

 After a power failure the set temperature remains stored. The set temperature will be reached within 24 hours.

3.7 High temperature alarm

An increase in the temperature in the freezer compartment (for example due to an earlier power failure) is indicated by:

- flashing of the alarm and freezer temperature indicators;
- sounding of the buzzer.

Press any button to reset the alarm.

The buzzer switches off.

The freezer temperature indicator shows the highest temperature reached for a

few seconds. Then show again the set temperature.

The alarm indicator continues to flash until the normal conditions are restored.

3.8 COOLMATIC function

If you need to insert a large amount of warm food, for example after doing grocery shopping, we suggest activating the COOLMATIC function to chill the products more rapidly and to avoid warming the other food which is already in the refrigerator.

1. Press Mode until the corresponding icon appears.
The COOLMATIC indicator flashes.
2. Press OK to confirm.
The COOLMATIC indicator is shown.

 The COOLMATIC function shuts off automatically after 52 hours.
To switch off the function before its automatic end, repeat the steps until the COOLMATIC indicator goes off.

3.9 FROSTMATIC function

The FROSTMATIC function accelerates the freezing of fresh food and, at the same time, protects foodstuffs already stored from undesirable warming.

1. Press Mode button until the corresponding icon appears.
The FROSTMATIC indicator flashes.
2. Press OK button to confirm.
The FROSTMATIC indicator is shown.

 The FROSTMATIC function shuts off automatically after 52 hours.
To switch off the function before its automatic end, repeat the steps until the FROSTMATIC indicator goes off.

3.10 DYNAMICAIR function

1. Press Mode until the corresponding icon appears.
The DYNAMICAIR indicator flashes.
2. Press OK to confirm.

The DYNAMICAIR indicator is shown.



The activation of the DYNAMICAIR function increases energy consumption. If the function is activated automatically, the DYNAMICAIR indicator is not shown (refer to "Daily use").

To switch off the function, repeat the steps until the DYNAMICAIR indicator goes off.

3.11 MinuteMinder function

The MinuteMinder function is to be used to set an acoustic alarm at the preferred time, useful for example when a recipe requires to cool down food products for a certain length of time or when a reminder is needed in order not to forget the bottles placed in the freezer for fast cooling.

1. Press Mode until the corresponding icon appears.

The MinuteMinder indicator flashes. The Timer shows the set value (30 minutes) for a few seconds.

2. Press the Timer regulator to change the Timer set value from 1 to 90 minutes.

3. Press OK to confirm.

The MinuteMinder indicator is shown. The Timer starts to flash (min).

It is possible to change the time at any time during the countdown and at the end by pressing the Temperature colder button and the Temperature warmer button.

At the end of the countdown, the MinuteMinder indicator flashes and an

audible alarm sounds. Press OK to switch off the sound and terminate the function.

It is possible to deactivate the function at any time during the countdown by repeating the function steps, until the indicator turns off.

3.12 Holiday mode

This function allows you to keep the refrigerator closed and empty during a long holiday period without the formation of a bad smell.



Empty the fridge compartment before turning the Holiday mode on.

1. Press the Mode button until the Holiday indicator icon appears.

The Holiday icon flashes.

The fridge temperature indicator shows the set temperature.

2. Press the OK button to confirm.

The Holiday icon appears.

To turn off the Holiday mode, repeat the procedure until the Holiday indicator icon goes off.

3.13 ChildLock function

Activate the ChildLock function to lock the buttons from unintentional operation.

1. Press Mode until the corresponding icon appears.

The ChildLock indicator flashes.

2. Press OK to confirm.

The ChildLock indicator is shown.

To deactivate the ChildLock function, repeat the procedure until the ChildLock indicator goes off.

4. DAILY USE



WARNING!

Refer to Safety chapters.

4.1 Initial power on



CAUTION!

Before inserting the power plug in to the outlet and switching on the cabinet for the first time, leave the appliance standing upright for at least 4 hours. This will assure a sufficient amount of time for the oil to return to the compressor. Otherwise the compressor or electronic components may sustain damage.

4.2 Storage of frozen food

When first starting-up or after a period out of use, before putting the products in the compartment let the appliance run at least 2 hours with the FROSTMATIC function turned on. The freezer drawers ensure that it is quick and easy to find the food package you want. If large quantities of food are to be stored, remove all drawers except for the bottom drawer which needs to be in place to provide good air circulation. On all shelves it is possible to place food that protrude until 15 mm from the door.

4.3 Freezing fresh food

The freezer compartment is suitable for freezing fresh food and storing frozen and deep-frozen food for a long time.

To freeze small amount of fresh foods it is not necessary to change the present setting.

To freeze fresh food activate the FROSTMATIC function at least 24 hours before placing the food to be frozen in the freezer compartment.

Place the fresh food to be frozen in the top compartment.

The maximum amount of food that can be frozen in 24 hours is specified on the **rating plate**, a label located on the inside of the appliance.

The freezing process lasts 24 hours: during this period do not add other food to be frozen.

When the freezing process is completed, return to the required temperature (see "FROSTMATIC Function").



In this condition, the refrigerator compartment temperature might drop below 0°C. If this occurs reset the temperature regulator to a warmer setting.

4.4 FreshBox module

The drawer inside the module is suitable for storing fresh food like fish, meat, seafood, because the temperature is lower here than in the rest of the fridge.



CAUTION!

Before placing or removing the FreshBox module inside the appliance, pull out the MaxiBox drawer and glass cover.

The FreshBox module is equipped with runners. At the time of its removal from the fridge compartment pull the module towards yourself and remove the basket by tilting its front downwards.

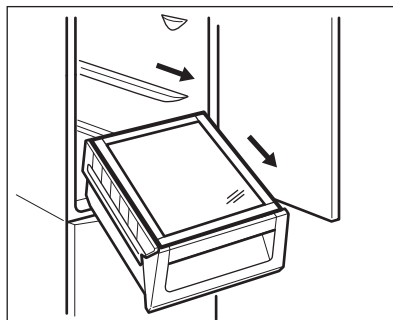

4.5 DYNAMICAIR

The refrigerator compartment is equipped with an automatic device that allows for rapid cooling of foods and more uniform temperature in the compartment.

It is possible to switch on the device manually (refer to DYNAMICAIR mode).

5. CARE AND CLEANING



WARNING!

Refer to Safety chapters.

5.1 Cleaning the interior

Before using the appliance for the first time, the interior and all internal accessories should be washed with lukewarm water and some neutral soap to remove the typical smell of a brand-new product, then dried thoroughly.



CAUTION!

Do not use detergents or abrasive powders, as these will damage the finish.

5.2 Periodic cleaning



CAUTION!

Do not pull, move or damage any pipes and/or cables inside the cabinet.



CAUTION!

Take care of not to damage the cooling system.



CAUTION!

When moving the cabinet, lift it by the front edge to avoid scratching the floor.

The equipment has to be cleaned regularly:

1. Clean the inside and accessories with lukewarm water and some neutral soap.
2. Regularly check the door seals and wipe clean to ensure they are clean and free from debris.
3. Rinse and dry thoroughly.
4. If accessible, clean the condenser and the compressor at the back of the appliance with a brush. This operation will improve the performance of the appliance and save electricity consumption.

The lowest shelf, dividing the cooler compartment from the compartment can be removed only for cleaning. To remove pull out the shelf straight.



To make sure fully functionality of the FreshBox compartment the lowest shelf and cover plates must be put back in their original position after cleaning.

The cover plates above the drawers in the compartment can be taken out for cleaning.

5.3 Defrosting

Your appliance is frost free. This means that there is no build up of frost when it is in operation, neither on the internal walls nor on the foods. The absence of frost is due to the continuous circulation of cold air inside the compartment, driven by an automatically controlled fan. The defrost water drains out through a trough into a special container at the back of the appliance, over the motor compressor, where it evaporates.

It is important to periodically clean the defrost water drain hole in the middle of the refrigerator compartment channel to prevent the water overflowing and dripping onto the food inside.

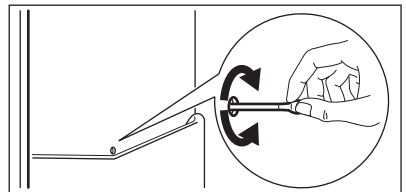

5.4 Periods of non-operation

When the appliance is not in use for long periods, take the following precautions:

1. Disconnect the appliance from electricity supply.
2. Remove all food.
3. Clean the appliance and all accessories.
4. Leave the door/doors open to prevent unpleasant smells.

6. TROUBLESHOOTING



WARNING!

Refer to Safety chapters.

6.1 What to do if...

Problem	Possible cause	Solution
The appliance is noisy.	The appliance is not supported properly.	Check if the appliance stands stable.
Audible or visual alarm is on.	The cabinet has been recently switched on or the temperature is still too high.	Refer to "Door Open Alarm" or "High Temperature Alarm".
	The temperature in the appliance is too high.	Refer to "Door Open Alarm" or "High Temperature Alarm".
A square symbol is shown instead of numbers on the Temperature Display.	Temperature sensor problem.	Contact the nearest Authorised Service Centre (the cooling system will continue to keep food products cold, but temperature adjustment will not be possible).
The lamp does not work.	The lamp is in stand-by.	Close and open the door.
The lamp does not work.	The lamp is defective.	Contact the nearest Authorised Service Centre.
The compressor operates continually.	Temperature is set incorrectly.	Refer to "Operation" chapter.
	Many food products were put in at the same time.	Wait some hours and then check the temperature again.
	The room temperature is too high.	Refer to climate class chart on the rating plate.
	Food products placed in the appliance were too warm.	Allow food products to cool to room temperature before storing.
	The FROSTMATIC function is switched on.	Refer to "FROSTMATIC function".
	The COOLMATIC function is switched on.	Refer to "COOLMATIC function".

Problem	Possible cause	Solution
The compressor does not start immediately after pressing the FROSTMATIC, or after changing the temperature.	This is normal, no error has occurred.	The compressor starts after a period of time.
The compressor does not start immediately after pressing the COOLMATIC, or after changing the temperature.	This is normal, no error has occurred.	The compressor starts after a period of time.
Water flows inside the refrigerator.	The water outlet is clogged.	Clean the water outlet.
	Food products prevent that water flows into the water collector.	Make sure that food products do not touch the rear plate.
Water flows on the floor.	The melting water outlet is not connected to the evaporative tray above the compressor.	Attach the melting water outlet to the evaporative tray.
Temperature cannot be set.	The FROSTMATIC or COOLMATIC function is switched on.	Switch off FROSTMATIC or COOLMATIC manually, or wait until the function resets automatically to set the temperature. Refer to "FROSTMATIC or COOLMATIC function".
DEMO appears on the display.	The appliance is in demonstration mode.	Keep the OK pressed for approximately 10 seconds until a long sound is heard and display shuts off for a short time.
The temperature in the appliance is too low/too high.	The temperature regulator is not set correctly.	Set a higher/lower temperature.
	The food products' temperature is too high.	Let the food products temperature decrease to room temperature before storage.
	Many food products are stored at the same time.	Store less food products at the same time.
	The FROSTMATIC function is switched on.	Refer to "FROSTMATIC function".
	The COOLMATIC function is switched on.	Refer to "COOLMATIC function".



If the advice does not lead to the desired result, contact the nearest Authorised Service Centre.

Only service is allowed to replace the lighting device. Contact your After Sales Service.

6.2 Replacing the lamp

The appliance is equipped with a longlife LED interior light.

7. INSTALLATION



WARNING!
Refer to Safety chapters.

7.1 Positioning

This appliance can be installed in a dry, well ventilated indoor where the ambient temperature corresponds to the climate class indicated on the rating plate of the appliance:

Climate class	Ambient temperature
SN	+10°C to + 32°C
N	+16°C to + 32°C
ST	+16°C to + 38°C
T	+16°C to + 43°C

7.2 Electrical Connection



CAUTION!
Any electrical work required to install this appliance should be carried out by a qualified electrician or competent person.



WARNING!
This appliance must be earthed.
The manufacturer declines any liability should these safety measures not be observed.

The wires in the mains lead are coloured in accordance with the following code:

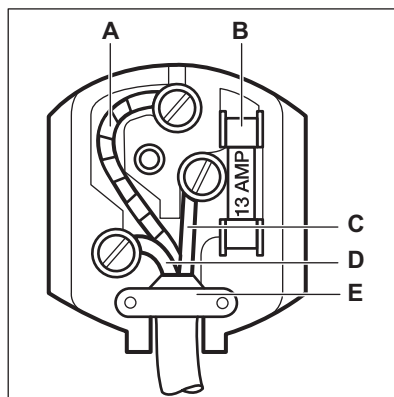

- **A** - green and yellow: Earth
- **C** - brown: Live
- **D** - blue: Neutral

As the colours of the wires in the mains lead of this appliance may not correspond with the coloured markings identifying the terminals in your plug, proceed as follows:

1. Connect the wire coloured green and yellow to the terminal marked either with the letter "E" or by the earth symbol \oplus or coloured green and yellow.
2. Connect the wire coloured blue to the terminal either marked with the letter "N" or coloured black.
3. Connect the wire coloured brown to the terminal either marked with the "L" or coloured red.
4. Check that no cut, or stray strands of wire is present and the cord clamp (**E**) is secure over the outer sheath. Make sure the electricity supply voltage is the same as that indicated on the appliance rating plate.
5. Switch on the appliance.

The appliance is supplied with a 13 amp fuse (B). In the event of having to change the fuse in the plug supplied, a 13 amp ASTA approved (BS 1362) fuse must be used.



WARNING!

A cut off plug inserted into a 13 amp socket is a serious safety (shock) hazard. Ensure that it is disposed of safely.

7.3 Installation of the appliance and door reversal



Please refer to separate instructions on installation (ventilation requirements, levelling) and door reversal.

7.4 Installation and replacing of the CLEANAIR CONTROL filter

On delivery the carbon filter is in a plastic bag to preserve performance. The filter

should be placed in the drawer before the appliance is turned on.

1. Open the drawer.
2. Take the filter out of the plastic bag.
3. Insert the filter in the drawer.
4. Close the drawer.

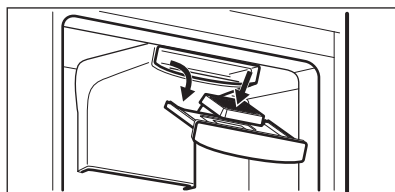

To get the best performance the carbon air filter should be changed once every year.

New active air filters can be purchased from your local dealer.

8. TECHNICAL INFORMATION

8.1 Technical data

Height	2000 mm
Width	595 mm
Depth	642 mm
Rising time	17 hours

Voltage	230 - 240 Volts
Frequency	50 Hz

The technical information are situated in the rating plate, on the external or internal side of the appliance and in the energy label.

9. ENVIRONMENT CONCERNS

Recycle the materials with the symbol . Put the packaging in applicable containers to recycle it. Help protect the environment and human health and to recycle waste of electrical and electronic appliances. Do not dispose appliances

marked with the symbol  with the household waste. Return the product to your local recycling facility or contact your municipal office.

www.aeg.com/shop



280154201-A-302014

