

IN PHASE

IPS 248BT

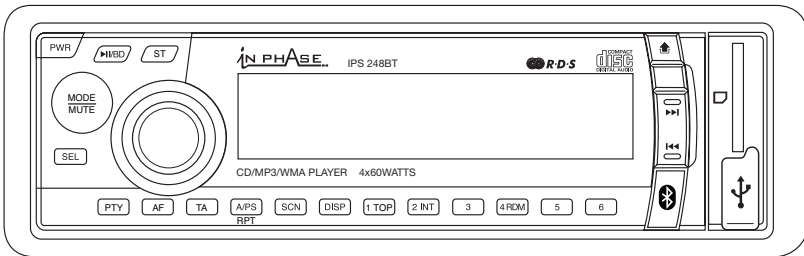



INSTRUCTION MANUAL

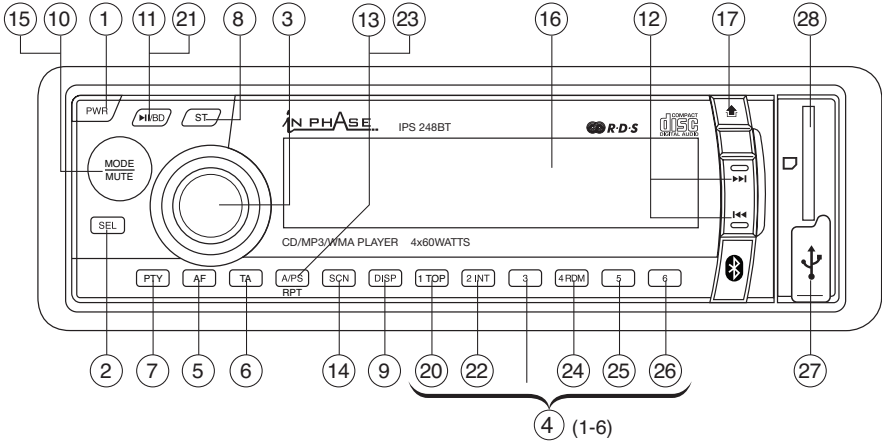

**Car Stereo CD/CDR/CDRW/MP3/WMA Player
with PLL MW/FM Stereo Radio
Radio Data System with PTY
USB / MMC / SD Card Input
Bluetooth Function in Mobile Phone
Flip Down and Detachable Front Panel System**

LOCATION OF PARTS AND CONTROLS



1. POWER ON/OFF ()
2. FUNCTION SELECT BUTTON: BASS/TREBLE/BALANCE/FADER/TA SEEK/MASK DPI/RETUNE/AUDIO DSP/LOUDNESS/ESP/CD MULTI/SCROLL/BEEP/STEREO/ LOCAL/PAIRING
3. VOL UP/VOL DOWN FOR BASS/TREBLE/BALANCE/FADER/TA SEEK/MASK DPI/RETUNE/AUDIO DSP/LOUDNESS/ESP/CD MULTI/SCROLL/BEEP/STEREO/ LOCAL/PAIRING
4. PRESET STATIONS (1,2,3,4,5,6)
5. 'AF' function (ALTERNATIVE FREQUENCIES)
6. 'TA' function (TRAFFIC ANNOUNCEMENT)
7. 'PTY' function (PROGRAM TYPE)
8. STEREO/MONO BUTTON (ST)
9. DISPLAY BUTTON (DISP)
10. MODE BUTTON (MODE)
11. BAND BUTTON (BD)
12. AUTOMATIC OR MANUAL TUNING (FREQ UP  OR FREQ DOWN  / CD TRACK/SEARCH BUTTON
13. AUTO SEEK SEARCH TUNING (A/PS)
14. 'SCAN' AUTOMATIC TUNING CONTROL (SCN)
15. MUTE BUTTON (MUTE)
16. LCD DISPLAY
17. PANEL RELEASE BUTTON ()
18. CD SLOT
19. CD EJECT BUTTON ()
20. TOP BUTTON
21. PAUSE BUTTON
22. INTRO BUTTON (Preview all Tracks)
23. REPEAT BUTTON
24. RANDOM BUTTON
- 25, 26. + 10 TRACK SEARCH UP/DOWN
27. USB PORT
28. MULTI-MEDIA CARD (MMC) / SD CARD SLOT

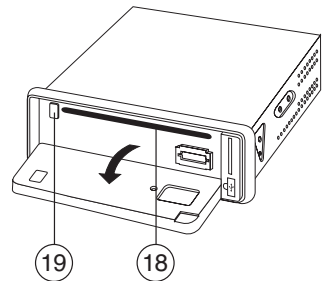

ISO CONNECTOR

RCA Jack Line Out : Red (right) White (left)
 RCA Jack Line In : Red (right) White (left)

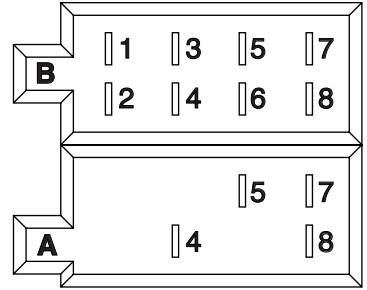

CONNECTOR A

- 1.
- 2.
- 3.
4. MEMORY +12V
5. AUTO ANTENNA OUTPUT
- 6.
7. +12V (TO IGNITION KEY)
8. GROUND

Note: (connector A no. 7) must be connected by car ignition key in order to avoid that car battery being drained when the car will be not used for long period.

CONNECTOR B

1. REAR RIGHT SPEAKER (+)
2. REAR RIGHT SPEAKER (-)
3. FRONT RIGHT SPEAKER (+)
4. FRONT RIGHT SPEAKER (-)
5. FRONT LEFT SPEAKER (+)
6. FRONT LEFT SPEAKER (-)
7. REAR LEFT SPEAKER (+)
8. REAR LEFT SPEAKER (-)

Maintenance

FUSE REPLACEMENT

If the fuse blows, check the power connection and replace the fuse. If the fuse blows again after the replacement, there may be an internal malfunction. In this case, consult your nearest repair center.

Warning

Use the specified amperage fuse for each lead. Use of a higher amperage fuse may cause serious damage.

INSTALLATION

PRECAUTIONS

- Choose the mounting location carefully so that the unit will not interfere with the normal driving functions of the driver.
- Avoid installing the unit where it would be subject to high temperatures, such as from direct sunlight or hot air from the heater, or where it would be subject to dust, dirt or excessive vibration.
- Use only the supplied mounting hardware for a safe and secure installation.
- Be sure to remove the front panel before installing the unit.

NOTE : Inclination angle for car radio installation must not exceed 30° otherwise the front panel will not open.

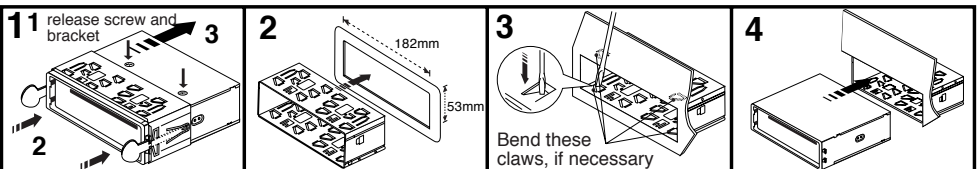
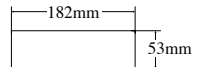

Note: Keep the release key in a safe place as you may need it in the future to remove the unit from the car.

TO SUPPORT THE UNIT

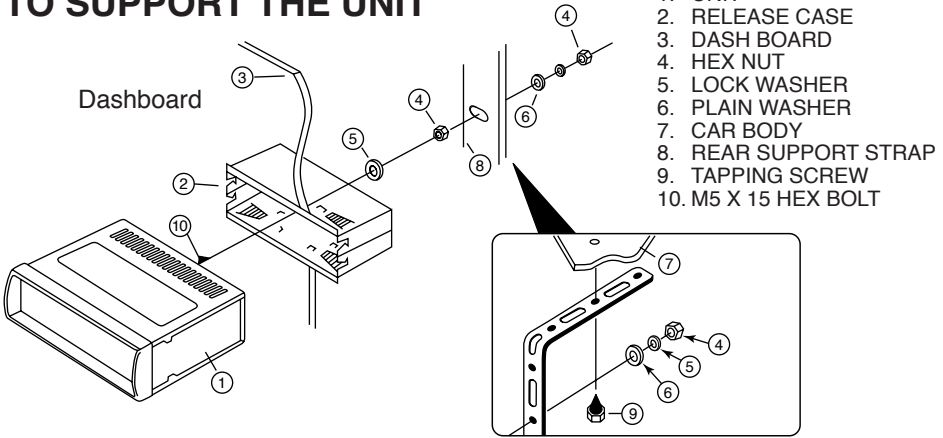

1. UNIT
2. RELEASE CASE
3. DASH BOARD
4. HEX NUT
5. LOCK WASHER
6. PLAIN WASHER
7. CAR BODY
8. REAR SUPPORT STRAP
9. TAPPING SCREW
10. M5 X 15 HEX BOLT

Detaching and attaching the front panel

The front panel of this unit can be detached in order to prevent the unit from being stolen.

FOLDING DOWN AND DETACHING/ATTACHING THE FRONT PANEL

Before detaching the front panel, be sure to press the PWR button (1) OFF first. Then press the  button (17), let the Front Panel arrive in horizontal position and detach the panel by pulling it towards you as illustrated.

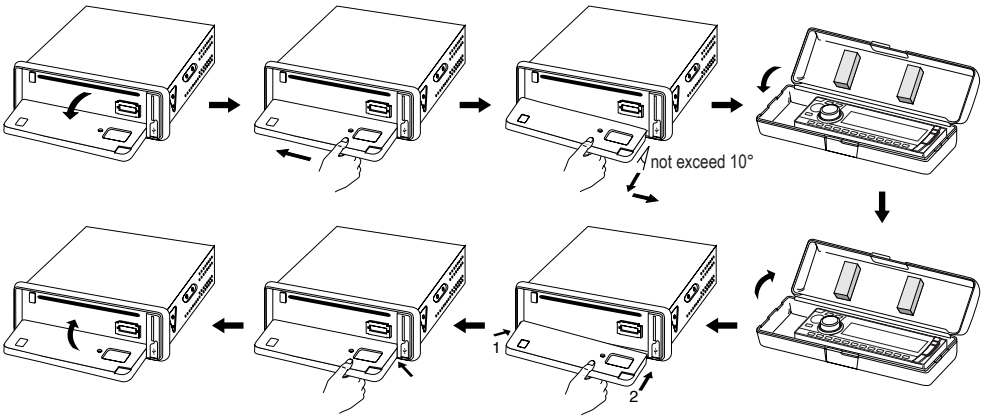

Notes:

- Do not press the front panel hard against the unit when attaching it. It can be easily attached by pressing it lightly against the unit.
- When you carry the front panel with you, put it in the supplied front panel case.
- Do not press hard or give excessive pressure to the display window of the front panel when attaching it to the unit.

1. POWER ON/OFF (PWR)

By pressing this key, the unit is turned on or off.
This unit is turned on by pressing any key.

2. FUNCTION SELECT BUTTON: BASS/TREBLE/BALANCE/FADER / TA SEEK/MASK DPI/RETUNE/AUDIO DSP/LOUDNESS/ESP/CD MULTI/BEEP/STEREO/LOCAL/PAIRING

Turning the VOL knob Right or Left (3), you can adjust VOL/BASS/TREB/BAL/FAD. To select other functions, press the SEL (2) button shortly until the desired functions is shown on the display. Figure 1 shows how control functions are selected using the SEL button.

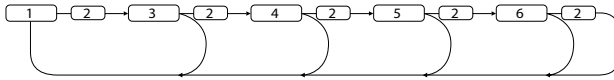

Fig. 1 Selection of sound control functions

1. VOL 2. SEL 3. BAS 4. TRE 5. BAL 6. FAD

Turning the VOL knob Right or Left. Increase or decrease the volume by turning or . These buttons can be used to adjust the BASS, TREBLE, BALANCE and FADER.

TA SEEK/TA ALARM (2)

When press the SEL button for more than 2 seconds, it is activated as selecting mode of these function.

TA SEEK Mode or TA ALARM mode is selected by or .

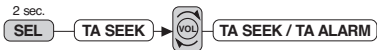

- TA SEEK mode:

When newly turned station does not receive TP information for 5 sec., the radio retunes to next station which has not the same station (PI) as the last station, but has the TP information.

In TA seek mode, the current station can be changed to the completely different station because the unit searches TP station when the field strength of the current station is very weak, or the current station has no TP signal.

- TA ALARM mode:

Any automatic retune mode is not activated, just can hear Beep sound.

MASK DPI (2)

When press the SEL button for more than 2 seconds, it is activated as selecting mode of these function.



MASK DPI: masked only the AF which has different PI.

MASK ALL: masked the AF which has different PI and NO RDS signal with field strength.

RETUNE L / S CONTROLS (2)

When press the SEL button for more than 2 seconds, it is activated as selecting Retune mode.

RETUNE L: Select 90 seconds as the initial time of automatic TA search.

RETUNE S: Select 30 seconds as initial time.



AUDIO DSP CONTROLS (2)

When press the SEL button for more than 2 seconds, it is activated as selecting mode of these function.

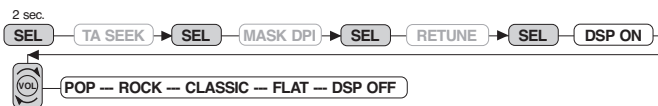

LOUDNESS CONTROLS (2)

When press the SEL button for more than 2 seconds, it is activated as selecting mode of these function.



LOUD ON/OFF mode is selected by or . The bass and treble response will be boosted.

ESP MODE (2)

When press the SEL button for more than 2 seconds, it is activated as 12 sec. or 45 sec. of ESP mode can be selected.



Note: 10 sec./40 sec. for CD, 120 sec. for MP3 automatically works.

MULTI CD SECTION MODE (2)

When press the SEL button for more than 2 seconds, it is activated as selecting mode of these function.



CD MULTI ON/OFF mode is selected by or . CD MULTI ON: Read multi section CD. CD MULTI OFF: Read first section only.

SCROLL MODE

When press the SEL button for more than 2 seconds, it is activated as selecting mode of these function.



SCROLL 1: Unit displays song details but no text scrolling.
SCROLL 2: Unit displays song details and scrolls the text information to the left.

BEEP MODE (2)

When press the SEL button for more than 2 seconds, it is activated as selecting mode of these function.

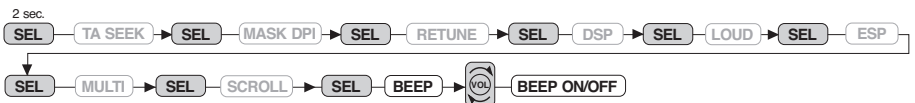

BEEP ON: BEEP sound can be heard from speaker when the buttons are pressed.

STEREO/MONO (2)

When press the SEL button for more than 2 seconds, it is activated as selecting mode of these function.



When FM stations are weak and are disturbed, listening can be improved by selecting MONO.

LOCAL/DX (2)

When press the SEL button for more than 2 seconds, it is activated as selecting mode of these function.

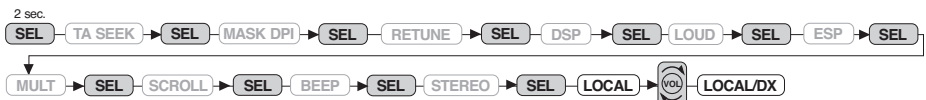

“Local” position in areas with strong signals to let radio stop at only strong stations during manual tuning (LOC appears). Select Distant position in areas with weak signals to listen to all stations.

PAIRING MODE (2)

When press the SEL button for more than 2 seconds, it is activated as selecting mode of these function. (Please refer to HOW TO PERFORM PAIRING on page 10)

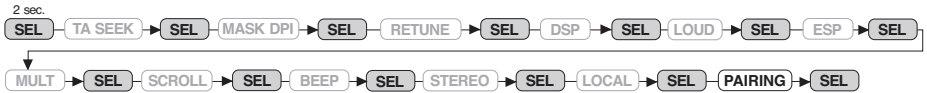

4. PRESET STATIONS (1,2,3,4,5,6)

(A) RADIO MODE:

When pressed momentarily, these keys select a preset station directly. When pressed longer than 1 sec., current station is stored in preset memory bank. When PTY mode is selected, the PTY switch is shared as follows:

PTY music group ---- PTY speech group ---- OFF

MUSIC

1. POP M, ROCK M
2. EASY M, LIGHT M
3. CLASSICS, OTHER M
4. JAZZ, COUNTRY
5. NATION M, OLDIES
6. FOLK M

SPEECH

1. NEWS, AFFAIRS, INFO
2. SPORT, EDUCATE, DRAMA
3. CULTURE, SCIENCE, VARIED
4. WEATHER, FINANCE, CHILDREN
5. SOCIAL, RELIGION, PHONE IN
6. TRAVEL, LEISURE, DOCUMENT

(B) CD/MP3/WMA PLAYER MODE:

1. PAUSE
2. INT
3. RPT
4. RDM

USING THE RDS FUNCTION

What is RDS?

The RDS (Radio Data System) is a digital information system developed by the EBU (European Broadcast Union). Piggy-backed on normal FM broadcasts, RDS offers a variety of information services and automatic retuning functions for RDS-compatible car stereos.

In 1988, RDS became available in the United Kingdom, France, West Germany, Ireland and Sweden. Test transmissions are being conducted in many other European countries. It is expected that RDS will be available in most western European countries in the near future.

5. 'AF/REG' function (ALTERNATIVE FREQUENCIES)

When pressed momentarily, AF/REG switching mode is selected.

When AF/REG switching mode is selected, the radio checks the signal strength of the AF all the time. When pressed long, it is activated as regional mode ON/OFF.

– Regional mode ON:

AF switching or PI SEEK is implemented to the station which have all PI codes same as current station. REG segment is turned on in LCD display.

– Regional mode OFF

The regional code in the format of PI code is ignored when AF switching or PI SEEK is implemented.

6. 'TA' function (TRAFFIC ANNOUNCEMENT)

When pressed momentarily, it is activated as TA mode on or off

When TA mode is on and traffic announcement is transmitted

– When the unit is CD/MP3 mode, it will switch to radio mode temporarily.

– If the volume level was under the threshold point, it will be raised to the threshold point.

– When TP station is received, TP segment is turned on in LCD display.

7. 'PTY' function (PROGRAM TYPE)

PTY MUSIC ---- PTY SPEECH ---- PTY OFF

While selecting PTY type, its selection is implemented by preset buttons as described in preset key. When PTY is selected, the radio starts to search corresponding PTY information, and stops if the corresponding PTY information is detected.

8. STEREO/MONO (ST)

When FM station is weak and disturbed, listening can be improve by selecting MONO.

9. DISPLAY (DISP)

When this key is pressed, it is operated as the conversion of each display mode as follow.

1) In case of receiving RDS station.

RADIO MODE

PS ---- CT ---- FREQ ---- PTY

CD/MP3/WMA PLAYER MODE

CDP ---- CT ---- PS ---- FREQ ---- PTY

2) In case of receiving NON RDS station

RADIO MODE

FREQ ---- CLOCK ---- NO PTY

CD/MP3/WMA PLAYER MODE

CDP ---- FREQ ---- CLOCK ---- NO PTY

Each display time is several seconds, and come back to 1'st position after several seconds.

Notes: • **CT** = clock time • **FREQ** = frequency • **CDP** = CD Player

10. MODE BUTTON (MODE)

By pressing this key, user can select. AUX/TUNER/CD-MP3/USB or MMC/SD mode.

11. BAND BUTTON (BD)

Each band is toggled cyclically by pressing this key FM1---FM2---FM3--MW1--MW2.

12. AUTOMATIC OR MANUAL TUNING (FREQ UP ►► OR FREQ DOWN ◀◀)

(A) RADIO MODE

When pressed momentarily, these keys are operated as MANUAL tuning mode.

When pressed longer than 1 sec., they are operated as SEEK tuning mode.

(B) CD/MP3/WMA PLAYER MODE

When pressed momentarily, they are operated as TRACK UP or TRACK DOWN mode.

When pressed longer than 1 sec., they are operated as CUE or REVIEW mode.

13. AUTO SEEK SEARCH TUNING (A/PS)

By pressing shortly, the radio searches for each preset station.

When field strength level is bigger than the threshold level of stop level, the radio is holding at that preset number for 5 sec. with releasing mute, and then searches again.

By pressing longer than 1 sec, and then 6 strongest stations are preset to the corresponding preset number. When AS operation is finished, the radio executes the preset scan.

14. 'SCAN' AUTOMATIC TUNING CONTROL (SCN)

This key is operated as RADIO SCAN. The operation is similar as normal search but different thing is holding 5 seconds on every station detected in RADIO SCAN mode.

15. MUTE BUTTON (MUTE)

Press and hold this button to mute the sound at once. Press again to return to previous volume level.

16. LCD DISPLAY

The Liquid Crystal Display will display the current state of the unit.

17. OPEN THE FRONT PANEL

Press REL button and the front panel will open.

CD/MP3/WMA CONTROL LOCATION OF PARTS

18. CD SLOT

Carefully insert the CD into the disc slot with the label side uppermost. The CD starts automatically play.

19. CD EJECT BUTTON

Press the EJECT button to remove the CD.

20. TOP BUTTON

Press to play first song of disc.

21. PAUSE BUTTON

During "PLAY", press (21) ►► button to "PAUSE". Press it again to resume play.

TRACK/SEARCH BUTTON (12)

FORWARD AND REVERSE TRACK SEARCH (or changing songs)

Press the SKIP button (**⏮** or **⏭**) during play to go to the desired track(song).

⏮REVERSE **⏭**FORWARD

Press and hold the SKIP button (**⏮** or **⏭**) during play to scan the disc at high speed. When the desired music section of the disc is found, release the button. Normal play will resume.

22. INTRO BUTTON (Preview all Tracks)

When this button is pressed, "INT ON" indication is displayed and the first several seconds of each track of the disc is played. Press again to stop intro and listen to track.

23. REPEAT BUTTON

When this button is pressed, "RPT ON" indication is displayed and play of the selected track will be continually repeated until the Track repeat mode is cancelled by pressing 'RPT' button again.

24. RANDOM BUTTON

When this button is pressed, "RDM ON" indication is displayed and each track of the disc is played in random instead of normal progression. To cancel RANDOM mode, press 'RDM' button (24) again.

25, 26. 10 TRACK UP/DOWN SELECT: (In case of MP3 files)

M5: 10 Track down / M6: 10 Track up

HOW TO SELECT MP3/WMA FILES

1. Searching Track:

- Press and hold "A/PS", then search track is activated.
- Press "SEL" button, then the first digit will flash.
- Rotary "VOL knob to right or left", select first digit desired.
- Press "SEL" button, then the first digit is fixed and second digit will flash.
- Rotary "VOL knob to right or left", select 2nd 3rd respectively.
- Then automatically the song selected will start.

2. Searching Character:

- Press and hold "A/PS". Press "A/PS" again, then character search mode is activated.
- Press "SEL" button, then "A" character is displayed.
- Rotary "VOL knob to right or left", you can select the desired letter.
- Press "SEL" button longer than 2 sec.
- The song with the same character you selected is displayed.
- Rotary "VOL knob to right or left", you can select the desired song.
- Press "SEL" button, then the song selected will start.

3. Searching File Name:

- Press and hold "A/PS". Press "A/PS" again, then directory search is activated.
- Press "SEL" button, then the first directory is displayed.
- Rotary "VOL knob to right or left", you can select the desired directory.
- Press "SEL" button again, then the directory is fixed and the first file name is displayed.
- Rotary "VOL knob to right or left", you can select the file you want.
- Press "SEL" button, then the song selected will start.

Connecting it to Portable MP3 Player

27. USB Port

Using USB cable to connect Your Portable MP3 Player.

28. MULTI-MEDIA CARD (MMC) / SD CARD SLOT

Support MP3 ID3 format music only.

*** IMPORTANT INFORMATION:**

BECAUSE OF THE GREAT VARIETY OF PRODUCTS WITH USB, SD AND MMC CARD PORTS AND THEIR SOMETIMES QUITE MANUFACTURER-SPECIFIC FUNCTIONS WE CAN NEITHER GUARANTEE THAT ALL DEVICES WILL BE RECOGNIZED NOR THAT ALL OPERATING OPTIONS THAT ARE POSSIBLE IN THEORY WILL ACTUALLY WORK

HOW TO USE BLUETOOTH IN YOUR CAR AUDIO

HOW TO PERFORM PAIRING

Before you can dial out from the car stereo, you must first perform PAIRING. Pairing is a procedure used to connect 2 Bluetooth devices together.

1. Press and hold **SEL** button for 2 seconds.
2. Press **SEL** button repeatedly until "PAIRING" displays.
3. Press and hold **SEL** button to engage pairing mode. "PAIRING" blinks on the display.
4. Turn on the Bluetooth feature of your mobile phone. Perform "Add Bluetooth device" from your mobile phone. The mobile will search for any Bluetooth devices within the range. Select "CAR BLUETOOTH" and enter Passkey: "0000" to connect to the car audio. (Please refer to the instruction manual of your mobile phone for Bluetooth Pairing).
5. The LCD will display "PAIRED" after successful pairing.

Note:

- If "DISCONN" shows instead of "PAIRING", it means the head unit currently is paired with another device. Press and hold **SEL** button to disconnect the connection and perform steps above again.
- "CAR BLUETOOTH" is the Bluetooth device name of the car stereo.
- Refer to your cellular user manual for the proper procedures of pairing Bluetooth devices.

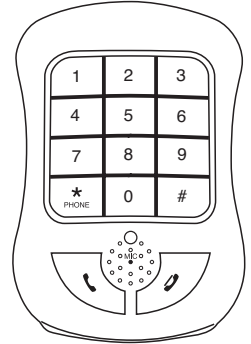

Audio Streaming

If your phone is "A2DP" format compatible, then you can play music in your mobile and the sound will be transferred to car head unit.



1. Make sure your mobile and the unit is properly paired and connected.
2. Play the music through your mobile music player software.
3. Press **MODE** repeatedly until "BT-PLAY" appears in the display. The sound will be transferred to the head unit.

Making Calls Using the Dial Keypad

You can make calls directly from the supplied Dial Keypad. Before you make calls, make sure that the devices are properly paired and the keypad cable properly connected to the back of the head unit.

1. Press and hold **PHONE** on the dial keypad.
2. Enter the phone number via the keypad and press  button to dial out. Press  button to make corrections when entering numbers.
3. Press  button to end call.

Answering / Hanging Up

To answer a call, press the  button on the dial keypad. Speak directly to the keypad's microphone. Once you have finished your conversation, press the  button to hang up.

Calls (Outgoing, Incoming)

The unit stores all the incoming and outgoing calls. Use this feature to check the numbers and make calls from it.

"OUT NUM" – outgoing calls made through the dial keypad.

1. Press and hold **PHONE** on the dial keypad then press and hold **SEL** button for 2 seconds. "OUT NUM" displays.
2. Press and hold **SEL** button again.
3. Rotate volume knob to search for entries and press  to call.

"IN NUM" – incoming calls received.

1. Press and hold **PHONE** on the dial keypad then press and hold **SEL** button for 2 seconds.
2. Press **SEL** button repeatedly until "IN NUM" displays.
3. Press and hold **SEL** button again.
4. Rotate volume knob to search for entries and press  to call.

Adding Contacts

The unit can save contact telephone number for quick access.

1. Press and hold **PHONE** on the dial keypad then press and hold **SEL** button for 2 seconds.
2. Press **SEL** button repeatedly until “*ADD NUM*” displays.
3. Press and hold **SEL** button again.
4. Using volume knob, enter the name of the contact. Press **SEL** button to save each character entered.
5. Enter the phone number. Press **SEL** button to save each number entered.
6. Press and hold **SEL** button to save entry.

Finding Contacts

After adding contacts, you can use this feature to find them.

1. Press and hold **PHONE** on the dial keypad then press and hold **SEL** button for 2 seconds.
2. Press **SEL** button repeatedly until “*FIND NUM*” displays.
3. Press and hold **SEL** button again.
4. Using volume knob, select the name of the contact and press  to call.

Deleting Contacts

1. Press and hold **PHONE** on the dial keypad then press and hold **SEL** button for 2 seconds.
2. Press **SEL** button repeatedly until “*FIND NUM*” displays.
3. Press and hold **SEL** button again.
4. Rotate **VOL** knob until the name of the contact you want to delete displays.
5. Press and hold “” for 2 seconds to delete contact.

How to Set Incoming Call Melody

1. Press and hold **PHONE** on the dial keypad then press and hold **SEL** button for 2 seconds.
2. Press **SEL** button repeatedly until “*MELODY*” displays.
3. Rotate **VOL** knob to the desired melody.

How to Set Incoming Call Ring Volume

1. Press and hold **PHONE** on the dial keypad then press and hold **SEL** button for 2 seconds.
2. Press **SEL** button repeatedly until “*RING*” displays.
3. Rotate **VOL** knob to the desired level.

How to Set Conversation Volume

1. Press and hold **PHONE** on the dial keypad then press and hold **SEL** button for 2 seconds.
2. Press **SEL** button repeatedly until “*TEL*” displays.
3. Rotate **VOL** knob to the desired level.

Disconnect Paired Devices

You can disconnect to an already paired Bluetooth device from your car stereo.

1. Press and hold **PHONE** on the dial keypad then press and hold **SEL** button for 2 seconds.
2. Press **SEL** button repeatedly until “*DISCONN*” displays.
3. Press and hold **SEL** button again to disconnect.

- **RESET**

Reset button is placed on the housing.

The reset button is to be activated for the following reason:

- Initial installation of the unit when all wiring is completed.
- All the function button do not operate.
- Error symbol on the display.

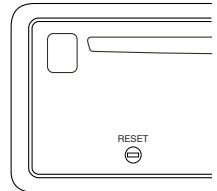

TECHNICAL SPECIFICATIONS

CD/MP3/WMA PLAYER SECTION

| | |
|-----------------------|----------------|
| Signal to Noise Ratio | > 60 dB |
| Channel Separation | > 50 dB (1kHz) |
| Frequency Response | 20Hz - 20 kHz |

TUNER (FM)

| | |
|------------------------|--------------|
| Frequency range | 87.5-108 MHz |
| Intermediate frequency | 10.7 MHz |
| Sensitivity | 2.8 μ V |
| Stereo separation | 30 dB |
| Signal to noise ratio | 50 dB |
| Channel step | 50 kHz |

TUNER (MW)

| | |
|------------------------|---------------|
| Frequency range | 522-1620 KHz |
| Intermediate frequency | 450 KHz |
| Usable Sensitivity | 32 dB μ V |

LINE-OUT

| | |
|-----------|---------|
| Output | 350mV |
| Impedance | 10k Ohm |

GENERAL

| | |
|-------------------|-------------------------------|
| Power Supply | 12V DC (10.8-15.6V allowable) |
| Speaker impedance | 4 or 8 ohm |
| Output power | 60W x 4CH |

Note: Specification and the design are subject to possible modification without notice due to improvements.