

Single-Package Heat Pump

INDEX

	Page
INSTALLATION	1-4
Step 1 — Check Equipment and Jobsite	1
• UNPACKAGE UNITS	
• INSPECT EQUIPMENT	
• COMPLETE OR CONSIDER SYSTEM REQUIREMENTS	
Step 2 — Mount Heat Pump Package	1
• ON THE GROUND: MOUNT HEAT PUMP ON AN ELEVATED FRAME POSITIONED ON A LEVEL CONCRETE PAD	
• ON THE ROOF: MOUNT UNIT ON A LEVEL PLATFORM OR FRAME	
Step 3 — Make Ductwork Connections	1
• CONNECT SUPPLY AND RETURN AIR DUCTWORK	
Step 4 — Provide for Cooling Cycle Condensate Disposal	4
• CONNECT DRAIN LINE TO UNIT	
Step 5 — Make Electrical Connections	4
• INSTALL BRANCH CIRCUIT FUSED DISCONNECT	
• BRING LINE POWER LEADS INTO UNIT	
• CONNECT GROUND LEAD TO GROUND LUG IN SPLICE BOX	
• SET INDOOR BLOWER MOTOR SPEED	
• CONTROL POWER WIRING	
• ELECTRIC HEATER INSTALLATION	
START-UP	6,7
SERVICE	7-12
MAINTENANCE	12,13

INSTALLATION

Step 1 — Check Equipment and Jobsite

UNPACKAGE UNITS — Move units to final location. Slide units from cartons taking special care not to damage unit.

INSPECT EQUIPMENT — File claim with shipping company if shipment is damaged or incomplete.

COMPLETE OR CONSIDER SYSTEM REQUIREMENTS before installing the 50YQ units.

Consult local building codes and National Electrical Code (NEC) for special installation requirements.

Provide sufficient space for coil airflow clearance, wiring, and servicing unit. (See Fig. 1.) Locate unit where supply and return air ducts can be conveniently brought out to unit duct connections.

Unit may be placed with duct side as close to building as condensate drain, top removal, duct connections and power connections permit. Position unit so water or ice from roof does not drop directly on top of unit or in front of coil. Provisions must be made for condensate drainage and defrost water disposal.

Roof installation method for 50YQ depends on building construction and special requirements of local building codes. Ensure that roof can support unit weight. Protect unit from prevailing winds to ensure adequate defrost.

Step 2 — Mount Heat Pump Package

ON THE GROUND: MOUNT HEAT PUMP ON AN ELEVATED FRAME POSITIONED ON A LEVEL CONCRETE PAD — See Fig. 2 for pad dimensions. Ensure pad does not obstruct coil slots in unit base pan. (Slots drain water during heating and defrost cycles. See Fig. 2 for drain slot locations). Construct pad a minimum of 6 in. thick to provide clearance under base pan coil slots for drainage and ice buildup. In areas where prolonged subfreezing temperatures or snowfall occur, increase clearance to 12 to 18 inches by constructing an angle-iron frame to support unit 12 to 18 in. off concrete base. Cross angle of frame must not obstruct base pan coil slots. See Fig. 3 for recommended frame construction. Alternate construction should follow dimensions. Extend a 24-in. gravel apron around pad for condensate and defrost water drainage field.

ON THE ROOF: MOUNT UNIT ON A LEVEL PLATFORM OR FRAME — Unit must be elevated for proper clearance as described under ground installation above. Roof design and water drainage must be planned to prevent unit and its duct flashing from sitting in water.

Step 3 — Make Ductwork Connections

CONNECT RETURN AND SUPPLY AIR DUCTWORK — Connect ductwork to unit supply and return air duct connections. Refer to Fig. 1 and Table 1 for unit supply and return air connection sizes and locations.

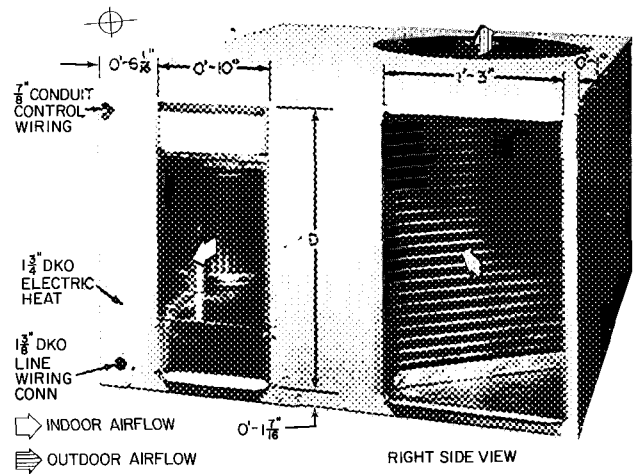
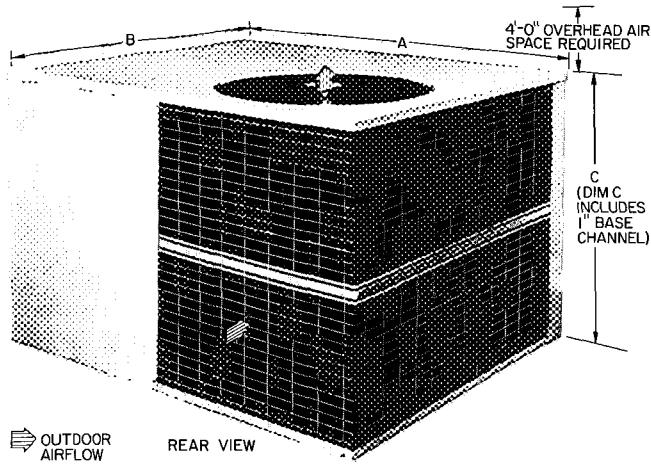

Certified dimension drawings are available on request

Fig. 1 – Dimensions and Connections

Table 1 – Installation Data (See Fig. 1)

UNIT	50YQ024	50YQ030	50YQ036	50YQ042	50YQ048
OPER WEIGHT (lb)	303	320	333	375	417
DIMENSIONS (ft-in.)					
A			4-0 ⁷ / ₁₆		
B			3-6 ¹ / ₄		
C*	1-11 ⁵ / ₈	1-11 ⁵ / ₈	1-11 ⁵ / ₈	2-3 ³ / ₈	2-7 ⁵ / ₈
DUCT CONN. (ft-in.)			Side-by-Side Rectangular		
D	1- 7 ³ / ₄	1- 7 ³ / ₄	1- 7 ³ / ₄	1-11 ³ / ₄	2-3 ³ / ₄
FILTER SIZE† (in.)					
Disposable	20 × 25	15 × 20 (2)	15 × 20 20 × 20	20 × 20 (2)	20 × 25 20 × 20
Permanent	15 × 20	20 × 20	20 × 25	20 × 25	15 × 20 (2)

*Dimension "C" includes 1 in built-in base support channels

†Recommended field-supplied filters are 1 in thick

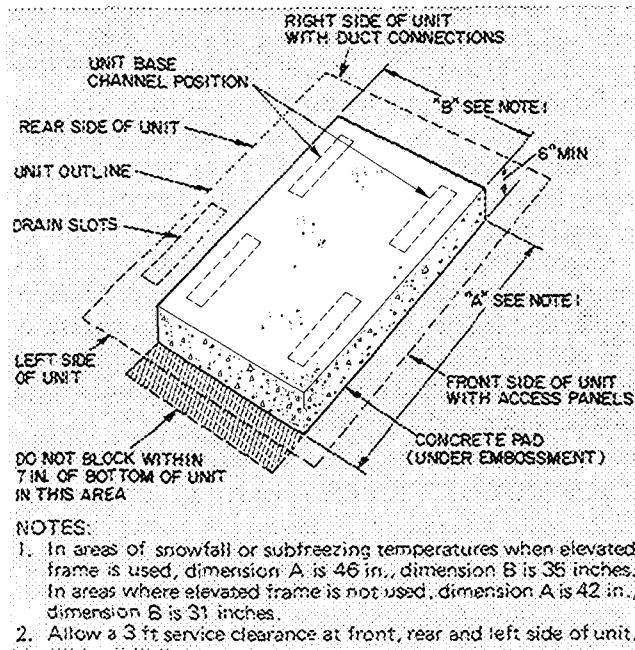

- NOTES:
1. In areas of snowfall or subfreezing temperatures when elevated frame is used, dimension A is 46 in., dimension B is 35 inches. In areas where elevated frame is not used, dimension A is 42 in., dimension B is 31 inches.
 2. Allow a 3 ft service clearance at front, rear and left side of unit.

Fig. 2 – Concrete Pad Dimensions

Flanges are provided on unit for rectangular duct connections. Figure 4 shows a typical duct system with 50YQ installed. Do not operate unit

longer than 5 minutes without ductwork. If necessary, refer to Carrier System Design Manual, Part 2, for system air duct design. When designing and installing ductwork, consider the following:

1. When connecting ductwork to unit, do not drill holes in area shown below. Coil may be damaged.

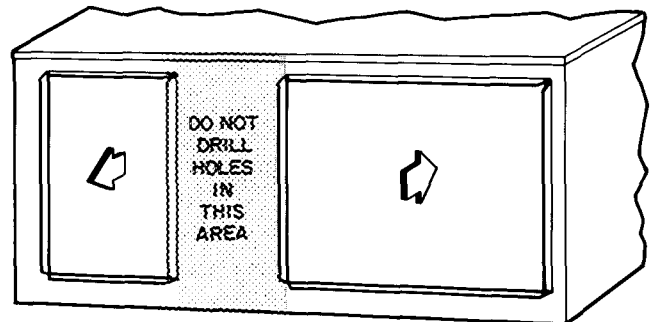

2. All units should have field-supplied filters installed in return air ductwork. Recommended sizes for filters are shown in Table 1.
3. Avoid abrupt duct size increases and reductions.
4. Use flexible connectors between ductwork and unit to prevent transmission of vibration. When electric heater is installed, use fireproof as-

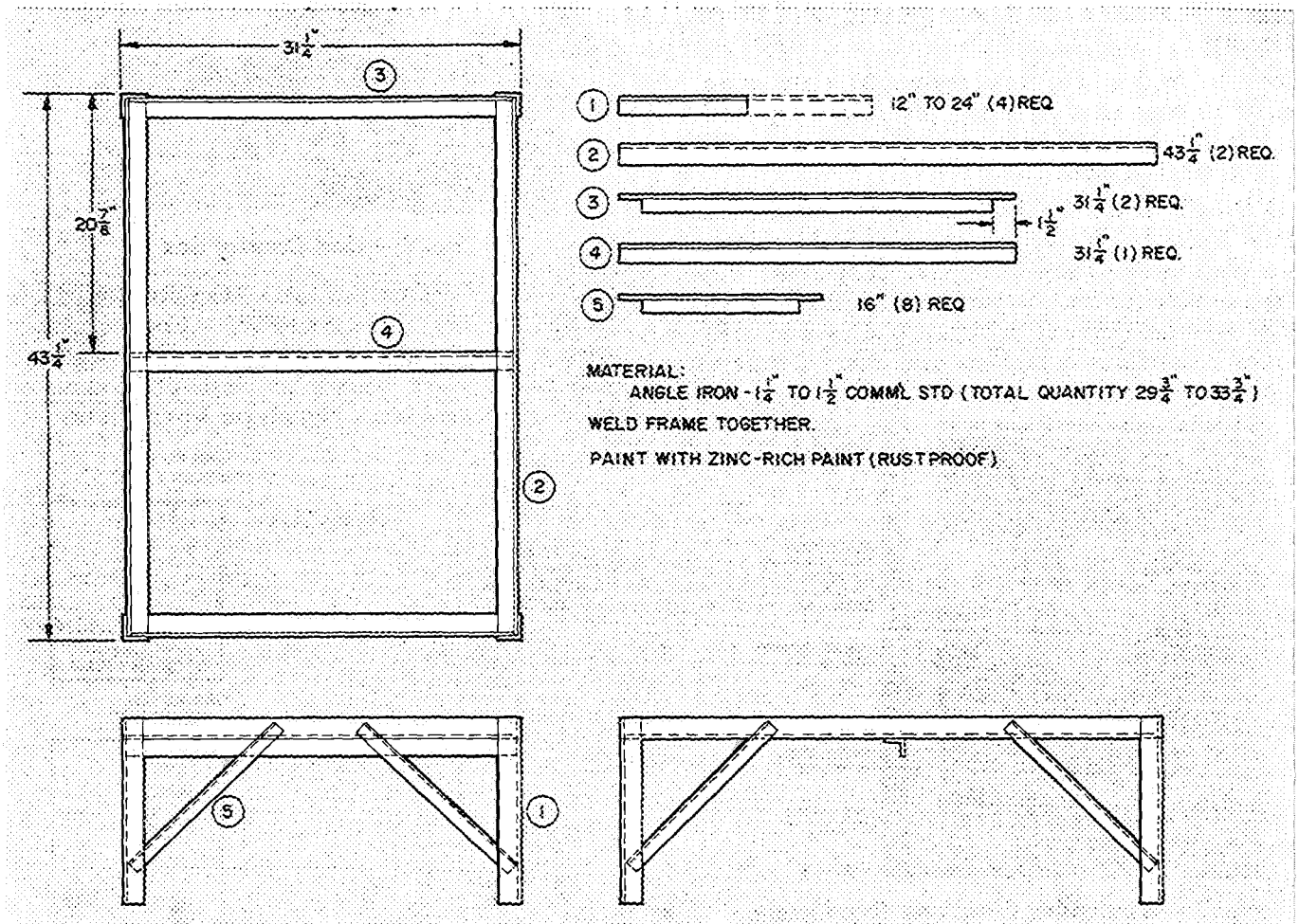

Fig. 3 – Heat Pump Mounting Frame

bestos (or similar heat resistant material) connector between ductwork and unit discharge connection. Heat resistant duct connector must extend 24 in. from electric heater element.

- e. Size ductwork for cooling air quantity (cfm). The minimum air quantity for proper heating/cooling operation and electric heater operation is 400 cfm per ARI cooling ton as listed below:

UNIT 50YQ	MIN CFM
024	833
030	1000
036	1183
042	1366
048	1633

Heater limit switches may trip at air quantities below those recommended.

- f. All external ductwork must be insulated and weatherproofed. Ducts passing thru unconditioned space must be insulated and covered with vapor barrier in accordance with the latest issue of SMACNA's (Sheet Metal and Air Conditioning Contractors National Association) and NESCA's (National Environmental Systems Contractors Association) minimum installation standards for residential heating and air conditioning systems.

- g. Secure all ducts to building structure. Weather-proof duct openings in wall or roof according to good construction practices.

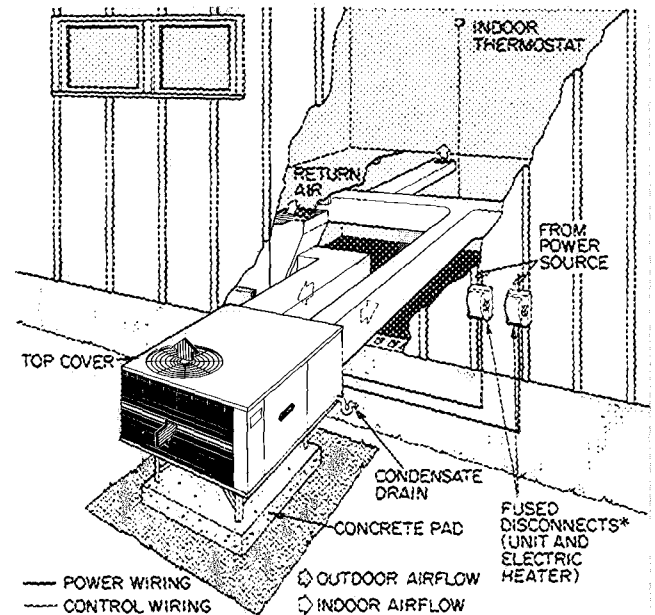

*Separate fused disconnect required for electric heater

Fig. 4 – Typical Installation – 50YQ

Step 4 – Provide for Cooling Cycle Condensate Disposal

Condensate may be drained directly onto gravel apron or connected by drain line(s) to a dry well. Condensate disposal methods must comply with local codes and practices.

CONNECT DRAIN LINE to rubber condensate drain fitting on side of unit (see Fig. 5). Use clamp provided. Install factory-supplied condensate trap (taped to indoor fan compartment for shipment) at end of drain line. If a drain line is not used, connect condensate trap to unit drain fitting as shown in Fig. 5.

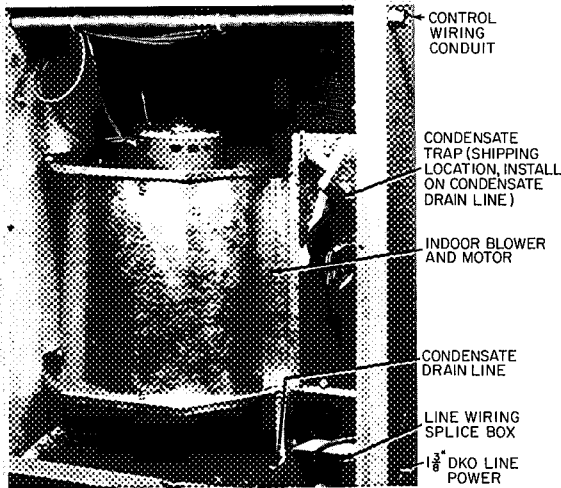

Fig. 5 – Condensate Drain and Trap Details

Step 5 – Make Electrical Connections

Field wiring must comply with local and national fire, safety and electrical codes. Voltage to unit must be within $\pm 10\%$ of voltage indicated on nameplate. On 3-phase units, phases must be balanced within 2%. Contact local power company for correction of improper line voltage.

Operation of unit on improper line voltage or with excessive phase imbalance constitutes abuse and may cause unit damage that could affect warranty.

See Table 2 for recommended wire and fuse sizes.

INSTALL A BRANCH CIRCUIT FUSED DISCONNECT of adequate size to handle unit starting current. Provide a separate fused disconnect for unit and for each accessory electric heater circuit as required. (See electric heater Installation, Start-Up and Service Instructions). Locate disconnect(s) within sight of and readily accessible from the unit, per Section 440-14 of National Electrical Code (NEC).

BRING LINE POWER LEADS INTO UNIT – Extend leads from fused disconnect thru hole provided (Fig. 1) into line wiring splice box (Fig. 6). Use copper or copper-clad aluminum wire. (Do not make connections with aluminum wire.)

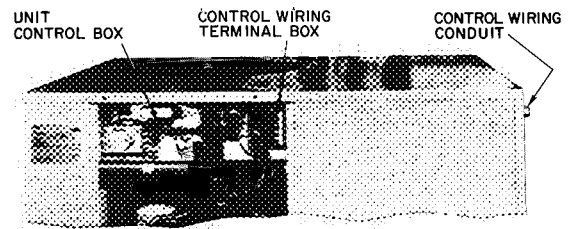
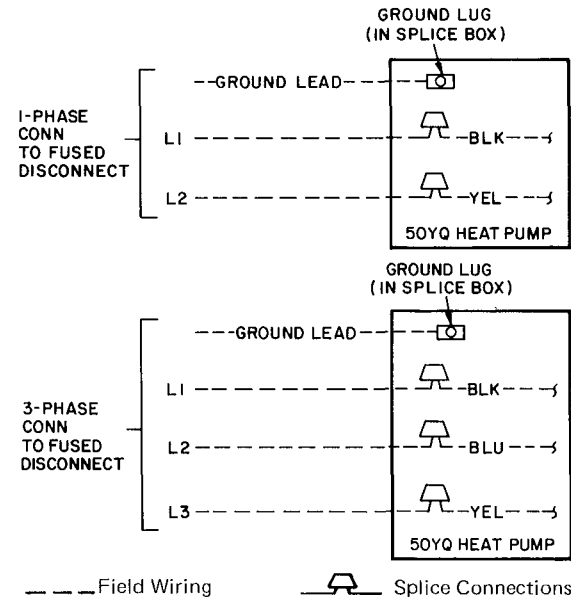

Fig. 6 – Unit Control Box

CONNECT GROUND LEAD TO GROUND LUG IN SPLICE BOX FOR SAFETY – Connect power wiring. See Fig. 7. Connect line power leads to yellow and black pigtails on single-phase units or yellow, blue and black pigtails on 3-phase units.



NOTE: Use copper or copper-clad aluminum wire

Fig. 7 – Line Power Connections

SET INDOOR BLOWER MOTOR SPEED – Refer to page 2 for minimum allowable air quantity for safe electric heater operation. Three-speed indoor fan motor is factory wired for high-speed operation. Fan motor is equipped with spade-type speed selector terminals marked 1, 2 and 3. For electric heater operation, set motor at “Low” for all units except 048; for 048, set motor at “High.”

MOTOR TERMINAL	1	2	3
FAN SPEED	High	Medium	Low

CONTROL POWER WIRING (24 v) is brought thru 7/8-in. conduit provided in unit, Fig. 1. Extend leads to unit control wiring terminal board in unit control box. Connect leads to terminal board as directed in Fig. 8.

The 50YQ unit transformer supplies 24-v power for complete system including accessory electric heater.

ELECTRIC HEATER INSTALLATION – For complete heater installation data, refer to accessory electric heater Installation, Start-Up and Service booklet.

Table 2 – Unit Electrical Data (60-Hz)

MODEL	V/PH	OPER VOLTAGE*		COMPRESSOR			IFM	OFM	BRANCH CIRCUIT				
		Max	Min	LRA	RLA	BCSC	FLA	FLA	Min Pwr Wire Size (AWG)	Max Ft Wire	Min Gnd Wire Size (AWG) †	Max Fuse Amps ‡	Min Circuit Amps
50YQ024	230/1	253	207	66	15.4	–	2.4	1.3	10	48	10	35	23
50YQ030				72	16.1	–	2.4	1.3	10	46	10	35	23.8
50YQ036				99	18.2	–	3.6	2.1	10	38	10	45	28.5
50YQ042				94	21	21.2	4.9	1.9	8	52	10	50	33.3
50YQ048				106	25	27.9	4.9	2.2	6	71	10	60	42
50YQ042	200/3	220	180	79	14.6	16.6	4.9	2.0	10	55	10	40	27.6
50YQ048				87	16.9	18.3	4.9	2.2	10	48	10	45	30
50YQ036	200/230/3	253	180	87	12.5/11.7	–	3.6	2.1	10	163/74	10	30	21.3/20.3
50YQ042	230/3	253	207	67	12.6	14.3	4.9	1.9	10	67	10	35	24.7
50YQ048				70	14.8	16.4	4.9	2.2	10	58	10	40	27.6
50YQ042	460/3	506	414	35	6.3	7.2	4.9	1.9	14	104	14	15	12.4
50YQ048				35	7.5	8.8	4.9	2.2	14	90	12	20	14.6
50YQ042	575/3	632	518	27	4.9	6.8	4.9	1.9	14	164	14	15	11.2
50YQ048				30	6	6.4	4.9	2.2	14	141	14	15	10.9

BCSC – Branch Circuit Selection Current
FLA – Full Load Amps
IFM – Indoor Fan Motor
LRA – Locked Rotor Amps
OFM – Outdoor Fan Motor
RLA – Rated Load Amps

*Permissible limits of the voltage range at which units will operate satisfactorily

†Required when using nonmetallic conduit

‡Maximum dual element fuse size

NOTE Copper wire size in table based on 60 C Use copper or copper-clad aluminum wire Use latest National Electric Code for wire sizing

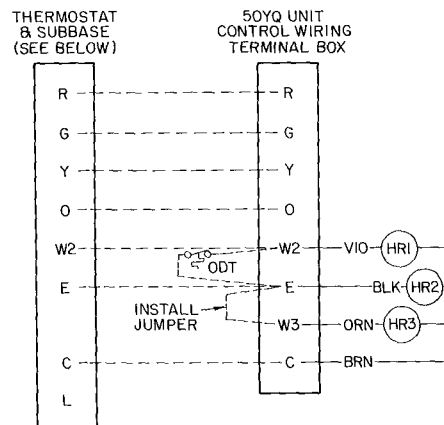
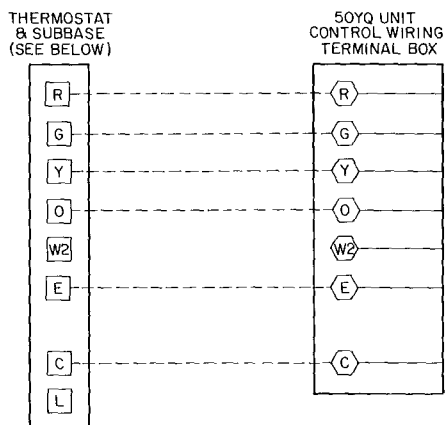

CHANGEOVER	SUBBASE	THERMOSTAT
Automatic	HH93AZ073	HH07AT071
Manual	HH93AZ075	HH07AT071
Manual	Subbase Included	HH07PZ085
Automatic	Subbase Included	HH07PZ086

ODT – Outdoor Thermostat
HR – Heater Relay

COOLING AND TWO-STAGE HEATING
 (Unit equipped with 88EJ Electric Heater, Emergency Heat, one Outdoor Thermostat)

COOLING AND ONE-STAGE HEATING
 (without Electric Heater)

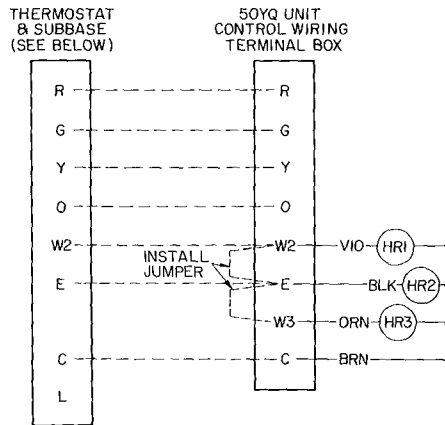

HR – Heater Relay

COOLING AND TWO-STAGE HEATING
 (Unit equipped with 88EJ Electric Heater, Emergency Heat, no Outdoor Thermostats)

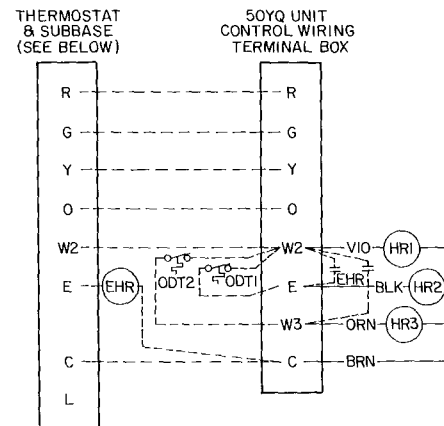

EHR – Emergency Heat Relay
HR – Heater Relay
ODT – Outdoor Thermostat

COOLING AND TWO-STAGE HEATING
 (Unit equipped with 88EJ Electric Heater, Emergency Heat Relay, two Outdoor Thermostats)

Fig. 8 – Control Connections – 50YQ

START-UP

The 50YQ units are equipped with a crankcase heater. It is recommended that heater be energized a minimum of 24 hours before starting unit. To energize heater only, turn thermostat to OFF position and close electrical disconnect to 50YQ unit.

Heat Anticipator Settings for Room Thermostat

Set anticipator settings for room thermostat according to Table 3. These settings may be changed slightly to provide a greater degree of comfort for a particular installation.

Table 3 – Thermostat Anticipator Setting

UNIT	FIRST STAGE ANTICIPATOR SETTING	ACCESS. ELEC HEATER (Kw)		SECOND STAGE ANTICIPATOR SETTING
		240 v	280 v	
50YQ024, 030,036, 042,048	Fixed	5.0	3.75	.26
		7.5	5.6	.26
		10.0	7.5	.26
		15.0	11.3	.52
		20.0	15.0	.52
		25.0	18.8	.52
		27.0	22.25	.78

Accessory Outdoor Thermostat provides adjustable outdoor control of accessory electric heaters of 15 Kw and over. This thermostat makes contact when a drop in outdoor temperature occurs. It energizes a stage of electric heat when the outdoor temperature setting is reached, provided the room thermostat is on the second stage of heating. One outdoor thermostat is recommended for each stage of electric heat after the first stage. Set the outdoor thermostat(s) progressively lower for each stage. Refer to heat load of building and unit capacity to determine the correct outdoor thermostat settings.

The accessory emergency heat relay is required when 2 outdoor thermostats are used. It is automatically energized by the manually operated emergency heat switch in the indoor thermostat subbase. The indoor thermostat locks out compressor and the relay bypasses the outdoor thermostats for electric heater operation during heat pump shutdown. When one outdoor thermostat is used, an emergency heat relay is not required. The emergency heat switch in the indoor thermostat subbase bypasses outdoor thermostat, locks out compressor and activates electric heater.

MOUNT OUTDOOR THERMOSTAT(S) – Locate maximum of 2 outdoor thermostats in the compressor section on the partition to the left of the 4-way valve. Fasten with sheet metal screws using engagement holes provided. Uncoil a short length of capillary and insert bulb into rubber grommet in the partition. Moisten bulb to assist insertion. Insert all but 1 in. of bulb. Secure remaining capillary.

MOUNT EMERGENCY HEAT RELAY in the compressor section on the partition to the left of

the 4-way valve using engagement hole provided. Fasten with sheet metal screws.

To Start Unit – (Ensure crankcase heater has been energized for 24 hours). Adjust the thermostat as follows:

1. Set selector switch at OFF.
2. Set fan switch as desired (FAN) (AUTO).
3. Turn on main disconnect switch(es) to unit.
4. Set thermostat dial to the desired temperature.
5. Set selector switch at HEAT or COOL. Check system refrigerant charge. See Refrigerant Charging.

Unit Single-Phase Compressors that are Equipped with a Compressor Start Thermistor (PTC device) (024,030,036) – When supply voltage is within 10% limit and compressor does not start, check the start thermistor with an ohmmeter.

CHECKING START THERMISTOR

1. Shut off all power to unit and wait 10 minutes for thermistor to cool to ambient temperature.
2. Unwire thermistor from circuit.
3. Measure resistance of thermistor with ohmmeter. Normal resistance readings are 25 ohms $\pm 20\%$ at 75 F ambient temperature.
4. If ohmmeter resistance reading is not within the $\pm 20\%$, the thermistor is defective and must be replaced.

If start thermistor is good and compressor does not start, disconnect the thermistor from starting circuit and give compressor a temporary capacitance boost as described below. Run compressor for 10 minutes, then shut off and allow system pressure to equalize. Reconnect start thermistor and try restarting compressor without boost capacitor. If after 2 attempts the compressor does not start, remove thermistor and add an accessory start capacitor relay package.

Temporary Capacitance Boost – If necessary, see Carrier Standard Service Techniques Manual, Chapter 2, for details. Use a 130-mfd start capacitor. Connect wires with insulated probes to each capacitor terminal. Touch probes to each side of run capacitor or to compressor motor terminals R and S. Start compressor; *pull probes away after 3 seconds. Discharge start capacitor.*

UNIT CONTROLS

High-Pressure Relief Valve (Safety Control) is located in compressor. Relief valve opens at a pressure differential of approximately 550 psi between suction (low side) and discharge (high side) to allow pressure equalization.

Internal Current and Temperature Sensitive Overload (Safety Control) resets automatically when internal compressor motor temperature drops to a safe level (overloads may require up to 1 hour to

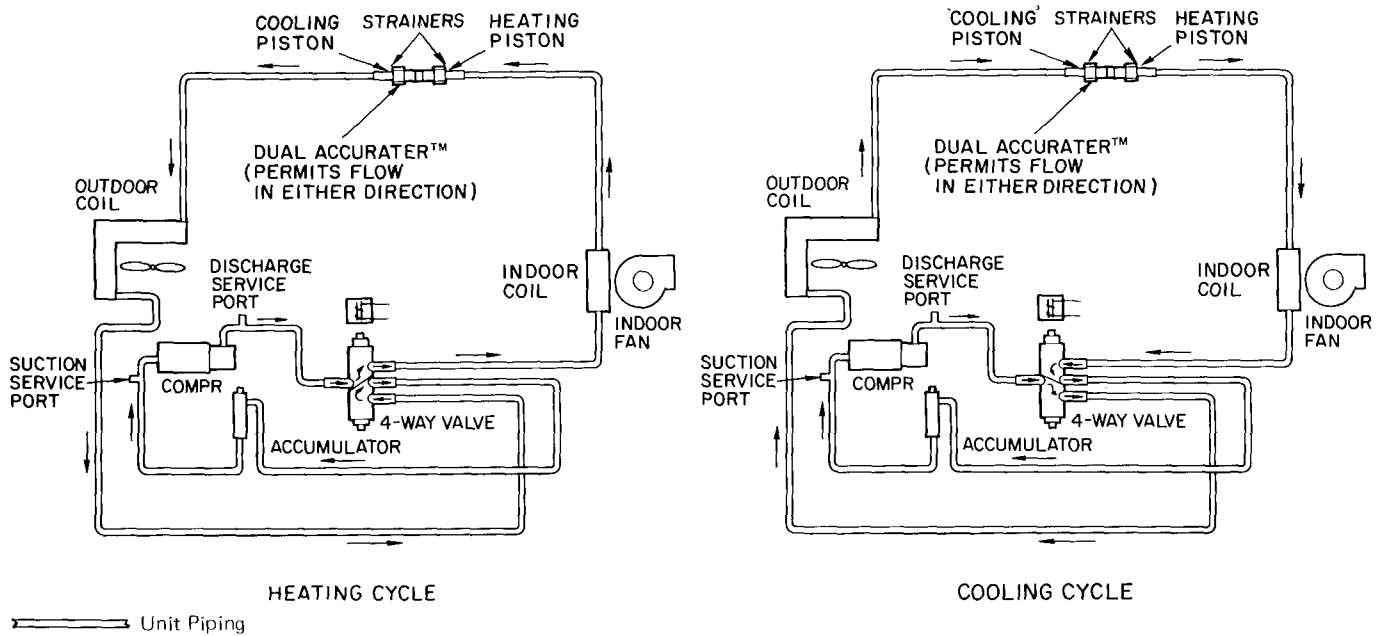

Fig. 9 - 50YQ Refrigerant Flow Diagrams

reset). When an internal overload is suspected of being open, check by using an ohmmeter or continuity tester. If necessary, refer to Carrier Standard Service Techniques Manual, Chapter 2, for complete instructions.

Defrost Control, consisting of a defrost timer, defrost thermostat and defrost relay, interrupts normal system heating operation to remove frost and ice formation on outdoor coil. Frost impairs unit performance. Defrost control simultaneously stops outdoor fan, energizes reversing valve solenoid to switch system into cooling cycle (outdoor unit as condenser, indoor unit as evaporator), and activates accessory electric heater. Unit can defrost every 90 minutes, but will do so only if outdoor temperatures are in the frosting temperature zone.

For heat pump to defrost, 2 conditions are necessary:

1. Defrost timer contacts must be closed.
2. Refrigerant temperature must be cold enough to cause defrost thermostat contacts to close. Contacts close at 27 ± 3 F.

Every 90 minutes of elapsed running time, the defrost timer contacts close for 10 seconds. If the defrost thermostat contacts are closed, the unit defrosts. The defrost timer limits defrosting period to 10 minutes. Normally the frost is removed and the defrost thermostat contacts will open to terminate defrosting before 10 minutes have elapsed. Defrost thermostat contacts open at $80 (\pm 6)$ F. When defrosting is terminated, the outdoor fan motor is energized and reversing valve solenoid is de-energized, returning unit to heating cycle.

HEAT PUMP CIRCUITS shown in Fig. 9 are refrigerant flow diagrams for heating and cooling cycles.

SERVICE

Refrigerant Charging - Unit refrigerant system is factory charged. When recharging is necessary, weigh in total charge indicated in Table 4. (Charge must be weighed in during heating season.) Remove any refrigerant remaining in system before recharging. If system has lost complete charge, evacuate system to 500 microns (29.7 in. vacuum) before recharging. Service port connections are provided on unit suction and discharge lines for evacuation and charging. (See Fig. 10 for service port location.) Dial-a-charge charging cylinder is an accurate device used to recharge systems by weight. These cylinders are available at refrigeration supply firms.

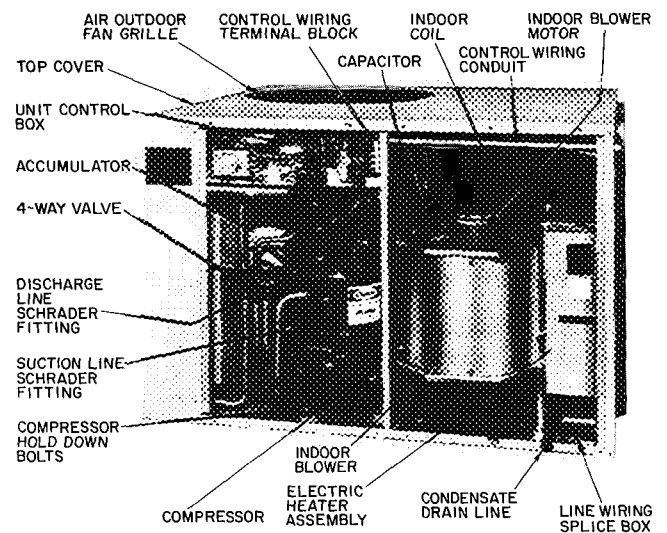

Fig. 10 - Component Location

Table 4 – Service Data

UNIT 50YQ	024	030	036	042	048
R-22 CHARGE* (lb)	5.4	5.7	5.15	6.7	7.3
Refrig Control			AccuRater™		
INDOOR FAN	Centrifugal – Direct Drive 3-Speed				
Rpm	1100/1050/900				
Diameter (in.)	9	9	9	10	10
Width (in.)	7	7	9	9	9
Range (cfm)	833–1040	1000–1250	1183–1480	1367–1708	1633–2040
Motor Hp	1/5	1/5	1/3	1/2	1/2
OUTDOOR FAN	Propeller – Direct Drive				
Cfm	2500	2500	2500	2700	3200
Rpm	1050	1050	1050	1050	1050
Diameter (in.)	20	20	20	20	20
Motor Hp	1/5	1/5	1/4	1/4	1/4

*Factory refrigerant charge

To check and/or adjust charge during cooling season, use correct Cooling Cycle Charging Chart (Fig. 11 thru 15) and follow Charging Chart Method below. The charging chart may also be used as an alternate method of recharging system.

To check *system operation* during heating cycle, use correct Heating Cycle Operation Check Chart (Fig. 16 thru 20.) These charts indicate whether a correct relationship exists between system operating pressures and air temperatures entering unit. If pressure and temperature lines do not intersect on chart, the system refrigerant charge may not be correct or other system abnormalities may exist. Do not use Operation Check Charts to adjust refrigerant charge. Weigh charge into system.

COOLING CYCLE CHARGING CHART METHOD

1. Operate unit a minimum of 10 minutes before checking charge, and after each charge adjustment.
2. Measure suction pressure by attaching a gage to unit suction service port. (See Fig. 10 for correct service port location.)
3. Measure outdoor (coil inlet) air dry-bulb temperature with service thermometer.
4. Using a sling psychrometer, measure wet-bulb temperature of air entering indoor fan coil.
5. Refer to correct Charging Chart. Locate on curves where outdoor air dry-bulb and indoor air wet-bulb temperature lines intersect.
6. From intersect point, project vertically downward to chart suction pressure line. Compare chart suction pressure to unit suction pressure (Step 2).
7. If unit suction pressure is lower than chart pressure, add refrigerant to system until chart pressure is reached. If unit suction pressure is higher than chart pressure, remove refrigerant until chart pressure is reached.

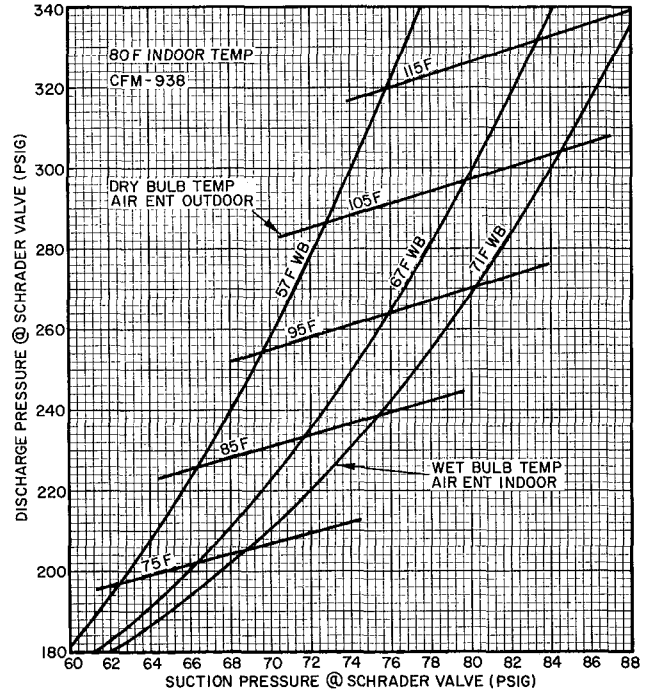

Fig. 11 – Cooling Charging Chart – 50YQ024

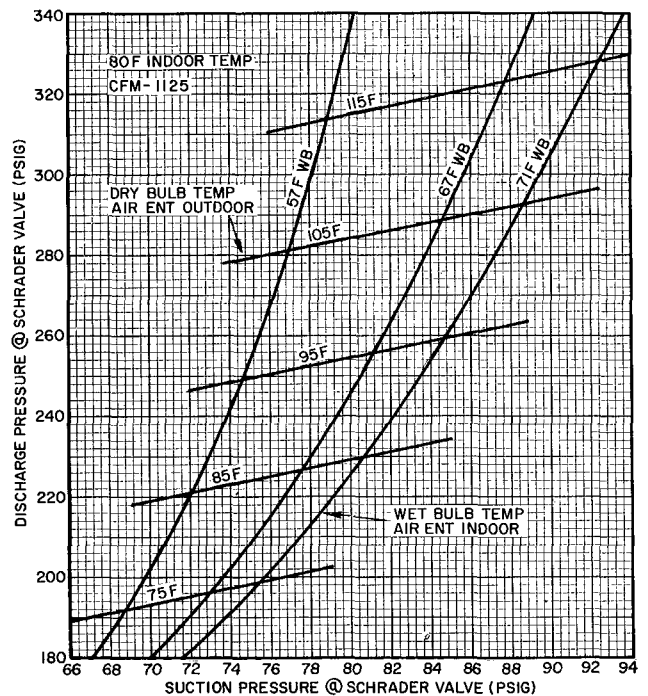

Fig. 12 – Cooling Charging Chart – 50YQ030

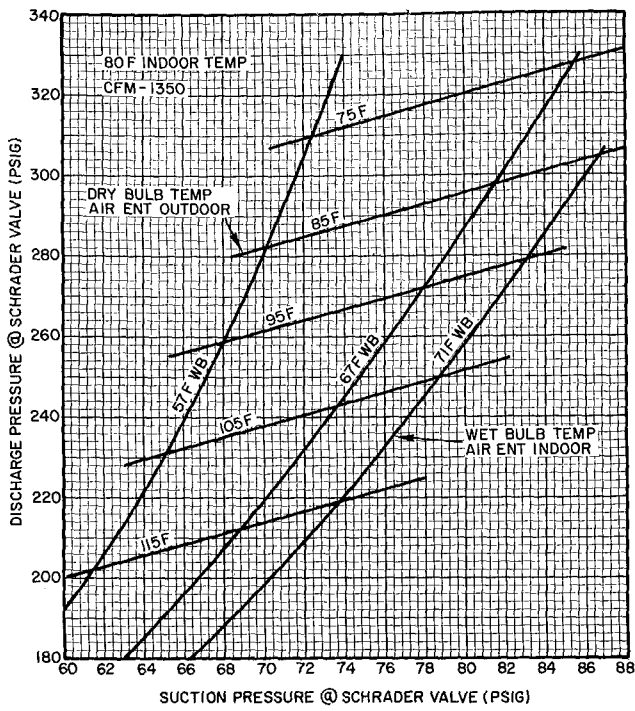

Fig. 13 – Cooling Charging Chart – 50YQ036

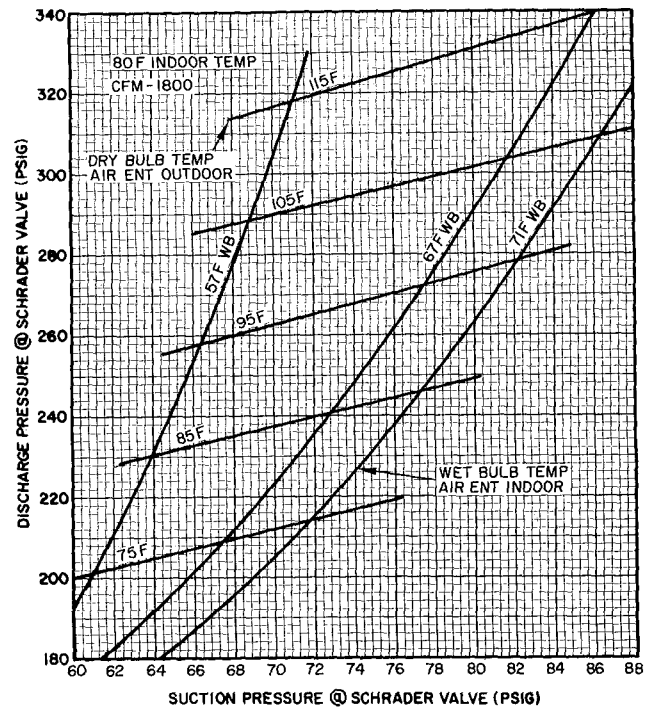

Fig. 15 – Cooling Charging Chart – 50YQ048

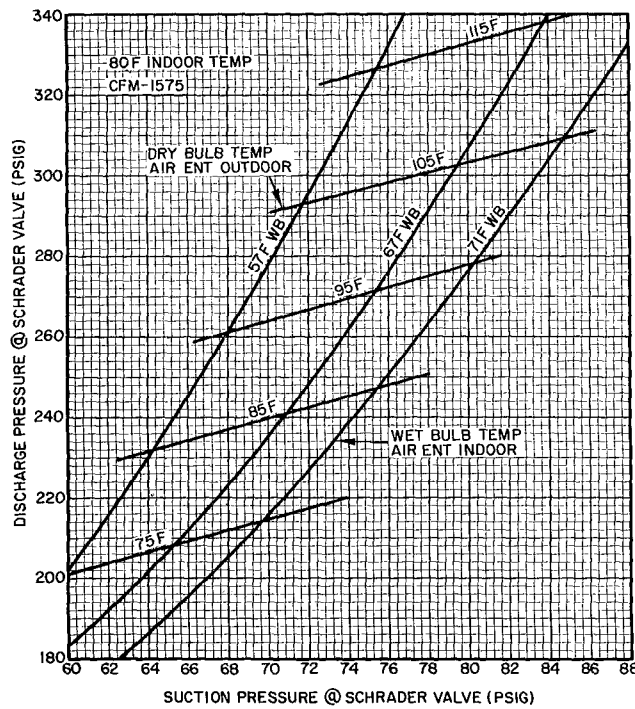

Fig. 14 – Cooling Charging Chart – 50YQ042

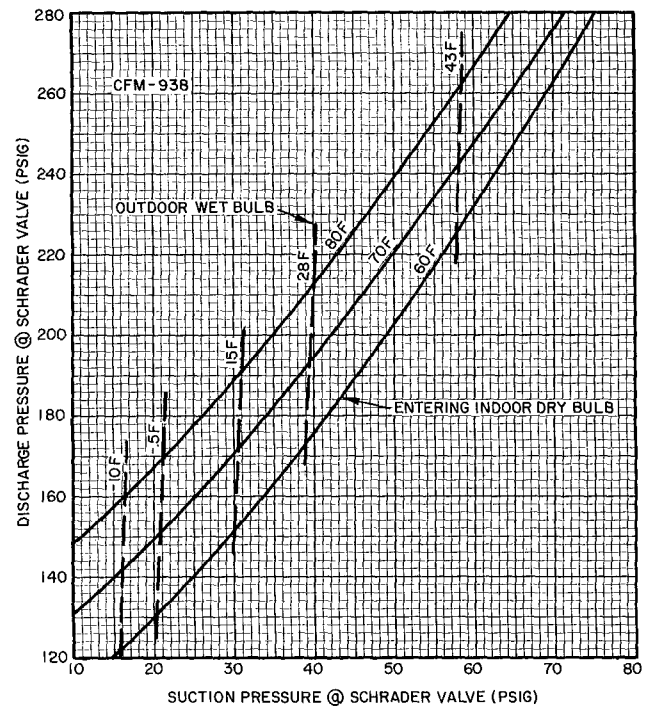

Fig. 16 – Heating Operation Check Chart – 50YQ024

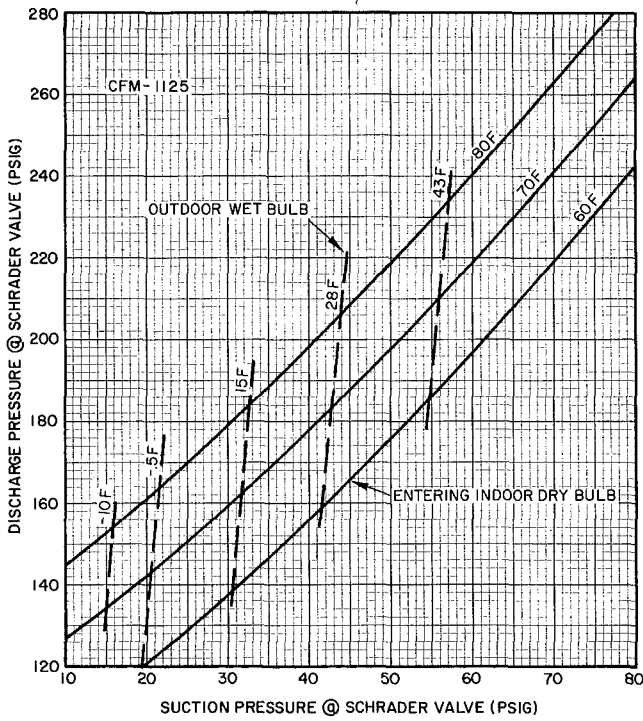

Fig. 17 – Heating Operation Check Chart
– 50YQ030

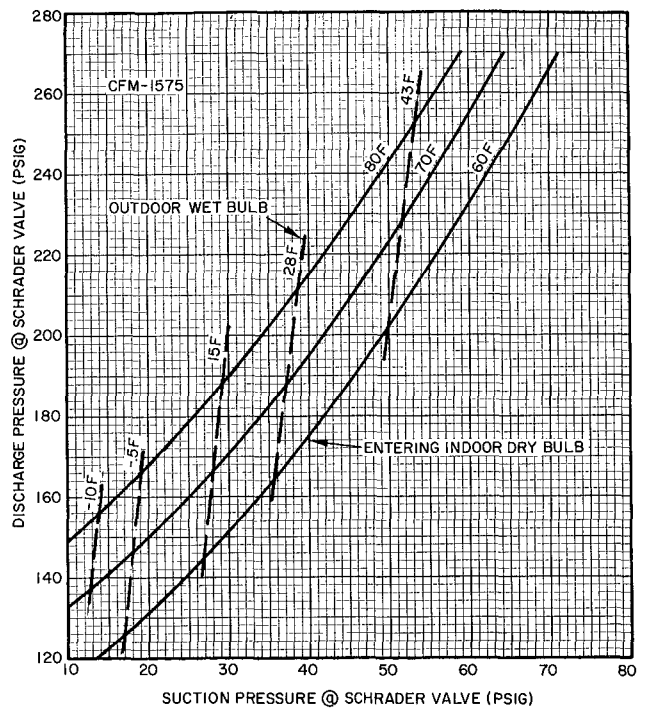

Fig. 19 – Heating Operation Check Chart
– 50YQ042

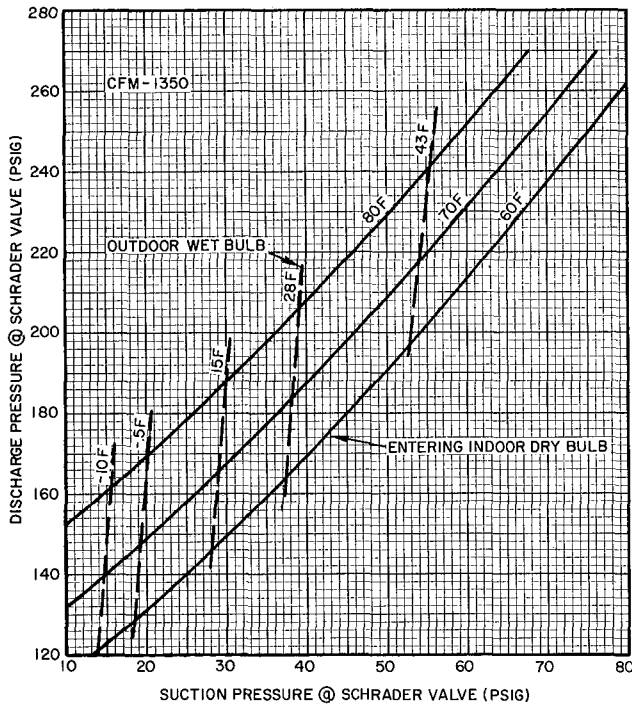

Fig. 18 – Heating Operation Check Chart
– 50YQ036

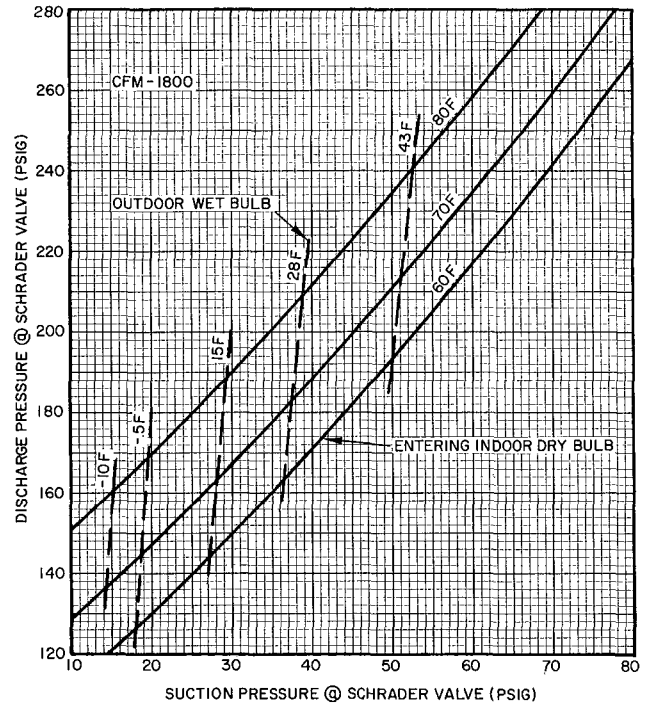
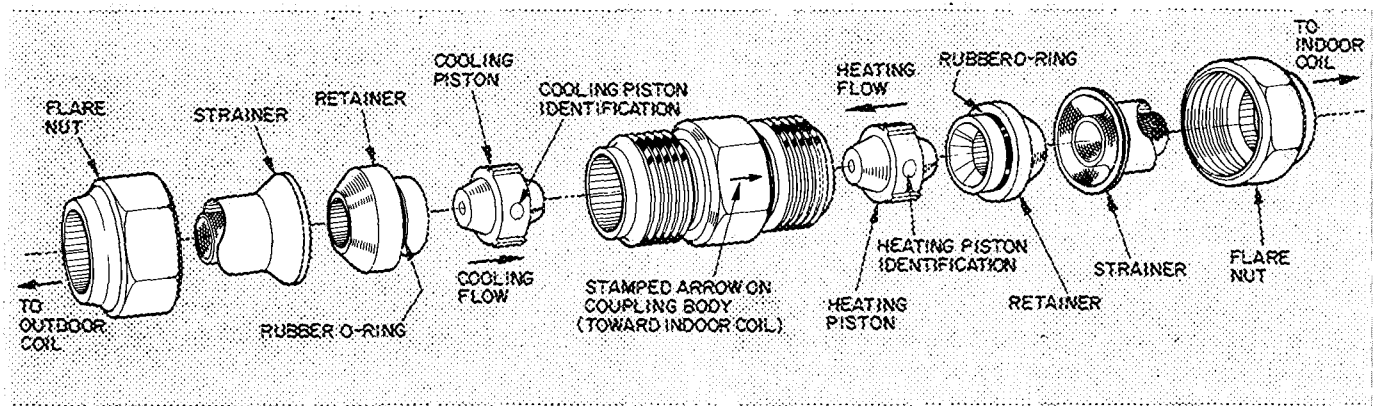

Fig. 20 – Heating Operation Check Chart
– 50YQ048



NOTE: Piston sizes are as tabulated. Location of piston with respect to coil is critical. Strainers are located in liquid line on each side of accumulator.

Fig. 21 – AccuRater (Dual-Piston) Components

AccuRater™ (Dual-Piston Type) Servicing – See Fig. 21 for dual-piston AccuRater components. The pistons have a refrigerant metering orifice thru them. The retainers form a stop for the pistons in the refrigerant bypass mode, and a sealing surface for liquid line flare connection. To check, clean or replace piston:

1. Shut off power to unit.
2. Remove refrigerant from unit.
3. Remove liquid line flare connections from AccuRater.
4. Note position of arrow on AccuRater body with respect to unit.
5. Pull retainer out of body being careful not to scratch flare sealing surface. If retainer does not pull out easily, carefully use vise grips to remove retainer. Replace scratched or damaged retainer.
6. Slide piston out by inserting a small soft wire thru metering hole (18-gage thermostat wire). See that metering hole, sealing surface around piston cones and fluted portion of piston are not damaged.
7. Chart on unit access panel illustrates proper arrangement and sizes of pistons.
8. Clean piston refrigerant metering orifice.
9. Replace container O-ring before reassembling AccuRater. Carrier O-ring part no. is 99CC501052.

LIQUID LINE STRAINERS (protects AccuRater) are made of wire mesh and located in the liquid line on each side of the AccuRater. The strainers are pressed into the line. Remove strainer by threading a #10 sheet metal screw into strainer and pulling the screw with pliers.

COMPRESSOR REMOVAL

See Table 5 for compressor information and Fig. 10 for component location. Follow safety codes, and wear safety glasses and work gloves. Have quenching cloth available (step 8).

Table 5 – Compressor Data

MODEL	PRODUCTION COMPRESSOR*	OIL RECHARGE (oz)
50YQ024	M24	44
50YQ030	M27	44
50YQ036	M34	44
50YQ042	P46	76
50YQ048	P53	76

*Refer to compressor nameplate for complete model number

CAUTION: Aluminum tubing is used in 50YQ unit coils. Do not overheat or place excessive strain on tubing or damage may result.

1. Shut off power to unit. Remove unit access panel, Fig. 22.
2. Remove refrigerant from unit using refrigerant removal methods described in Carrier Standard Service Techniques Manual, Chapter 1.
3. Remove core from suction and discharge line Schrader valves.
4. Disconnect compressor wiring at compressor terminal box.
5. Using a tubing cutter, cut suction and discharge lines at convenient place near compressor for easy reassembly to new compressor with copper slip couplings.

CAUTION: Excessive movement of copper lines at compressor may cause a break where lines connect to other system components.

6. Remove crankcase heater from compressor base.
7. Remove compressor hold-down bolts and lift compressor out.
8. Carefully unbraze suction and discharge line piping stubs from compressor. If oil vapor in piping stubs ignites, use quenching cloth.

CAUTION: Muffler may contain quantity of oil.

9. Braze piping stubs (removed in step 8) on new compressor.

10. Install new compressor in unit. Braze suction and discharge lines to compressor piping stubs (at points where cut, step 5) using field supplied copper couplings. Ensure compressor hold-down bolts are in place. Connect wiring.
11. Clean system. Add new suction line filter-drier as described below.

NOTE: If a compressor failure was caused by motor winding burnout, the by-products of the burnout must be separated from the circulating refrigerant. This must be done before the by-products enter the reversing valve or accumulator and render parts inoperative. Burnout by-products can cause future system operating problems if left in the system.

Clean the system by installing a suction line drier in the refrigerant line where the suction gas enters the reversing valve. During the cooling cycle, this is the line from the indoor coil running across the top of compressor compartment, during heating cycle, install drier in line between outdoor coil and reversing valve. If possible, run unit in cooling mode when cleaning system as installation of temporary suction drier is simplified.

For drier installation during heating cycle, cut vertical line below reversing valve to install fittings and tubing as suction drier must be placed outside of cabinet. Fabricate and install a temporary access panel to provide protection against entry and possible electrical shock hazard. To provide protection for the 4-way valve, do not place filter-drier between 4-way valve and accumulator. Since the suction drier works on one mode only, temporarily wire the unit in the selected mode (heating or cooling, based on suction drier location). To insure cooling operation only, install a jumper between terminals "R" and "O" on the low voltage terminal board. For heating operation only, remove and insulate one of the reversing valve solenoid leads. Run unit for 48 hrs. and check oil for acidity. If satisfactory, remove suction line drier. Refer to and follow procedure under AccuRater™ Servicing for cleaning of AccuRater. Rewire unit to normal condition. Triple evacuate and recharge unit.

12. Evacuate and recharge unit.

Filter-Drier — Install an accessory 50YQ900001 reversible, liquid line filter drier assembly. Remove dual piston AccuRater — save pistons. Cut 11 in. from liquid line. Install flare nut on new end of line and flare line. Install new strainers from accessory package. Following the instructions in accessory package, install filter-drier package components.

NOTE: Follow instructions carefully as AccuRater piston locations are reversed from those shown when a filter-drier is not used.

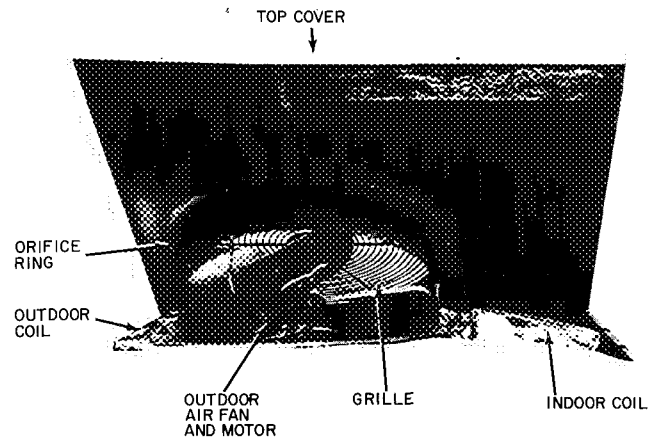

Fig. 22 — Component Location

MAINTENANCE

Lubrication

COMPRESSOR contains factory oil charge. Replace oil when lost. See Table 5 for oil recharge. If necessary, refer to Carrier Standard Service Techniques Manual, Chapter 1, page 1-21, for oil recharging procedure. Use Carrier PP33-1, Texaco Capella B or Suniso 3G oil.

FAN MOTOR BEARINGS are prelubricated for 3 years heavy duty or 5 years normal duty. When lubrication is necessary, send motor to authorized motor repair shop.

Indoor Coil

CAUTION: Before performing recommended maintenance, be sure main power switch to unit is turned off.

COIL — Lift or remove unit top cover for access to indoor coil. See Fig. 22. Inspect coil periodically. Clean as described under Outdoor Coil below.

Condensate Drain — Clean condensate drain trap with bottle brush; then flush condensate pan beneath indoor coil with clean water. Ensure water flows freely thru condensate drain.

INDOOR BLOWER WHEEL should be centered in blower housing. To adjust wheel, remove blower housing assembly as described below. Loosen setscrew holding wheel to motor shaft. Adjust wheel and retighten setscrew.

Indoor Blower Removal — See Fig. 23. Disconnect motor wiring. Remove sheet metal screws holding blower in place. Slide out complete wheel motor and orifice assembly.

Cleaning Indoor Fan Wheel — Remove caked-on dirt from fan wheel and housing with brush, warm water and detergent. When replacing blower assembly, ensure fan wheel is centered in housing.

Outdoor Coil

COIL — Lift or remove top cover for access to outdoor coil. See Fig. 22. Inspect coil periodically.



Fig. 23 – Indoor Blower Removal

Clean coil with water at the beginning of every cooling season or more often if required. Use ordinary garden hose at a pressure high enough to clean efficiently. For best results, spray coil fins from inside-to-outside the unit or top to bottom between rows of tubing. For 2-row coils, separate rows by removing screws at hairpin end. Spread coils sufficiently to wash between rows. Replace screws after cleaning. Flush dirt from base pan by

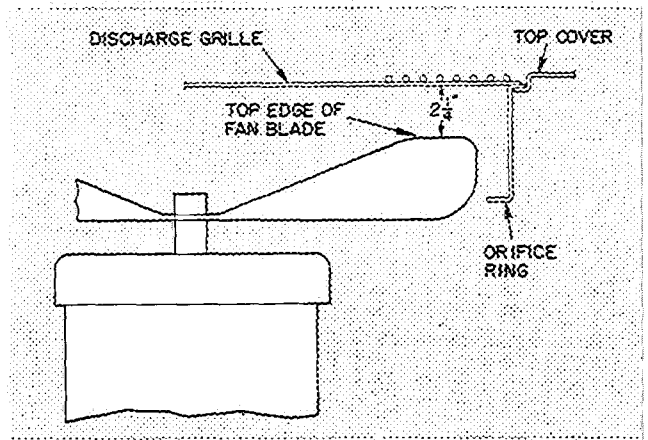

Fig. 24 – Outdoor Air Fan Adjustment

spraying water thru top of unit. Avoid splashing mud on coil or water on the fan motor and electrical control box.

OUTDOOR FAN POSITION – Required fan position is shown in Fig. 24. Adjust fan by loosening setscrews and moving blades up or down.

OUTDOOR FAN AND MOTOR REMOVAL – Remove screws holding outdoor coil fan grille in place. Disconnect fan motor leads from controllers and capacitor. Lift complete fan, motor, and orifice assembly (Fig. 22) out of unit. After replacing fan motor assembly, reconnect fan motor leads.

Return Air Filter (Field Supplied) – Replace throwaway filter 4 times a year. Clean permanent-type filter a minimum of 4 times yearly. Flush permanent filter with hot water, steam or soak in mild solution of soap or detergent and water. Allow filters to dry and replace. Refer to filter manufacturer's instructions, as required, for other types of filters.

TROUBLESHOOTING CHART – COOLING CYCLE

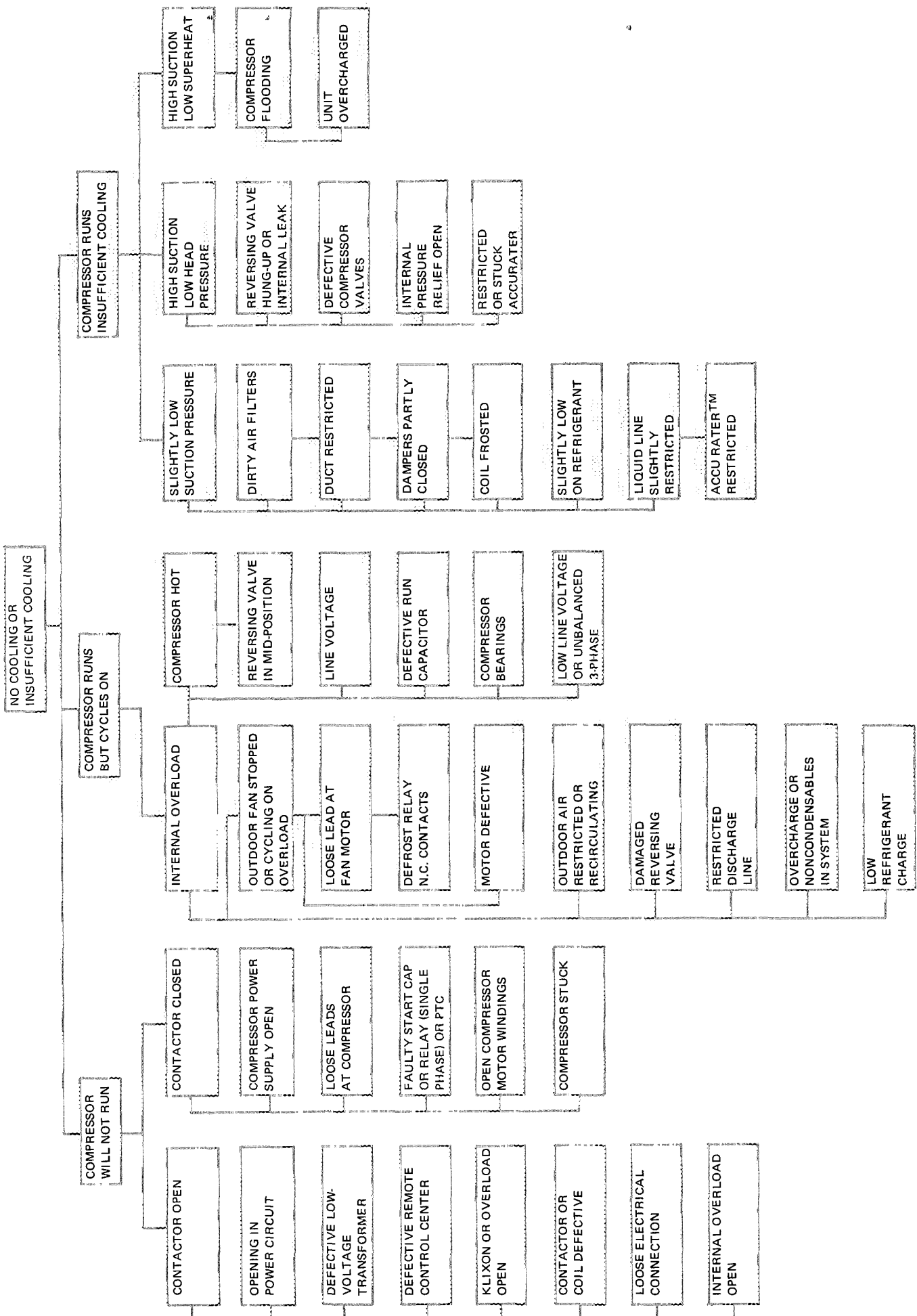

TROUBLESHOOTING CHART — HEATING CYCLE

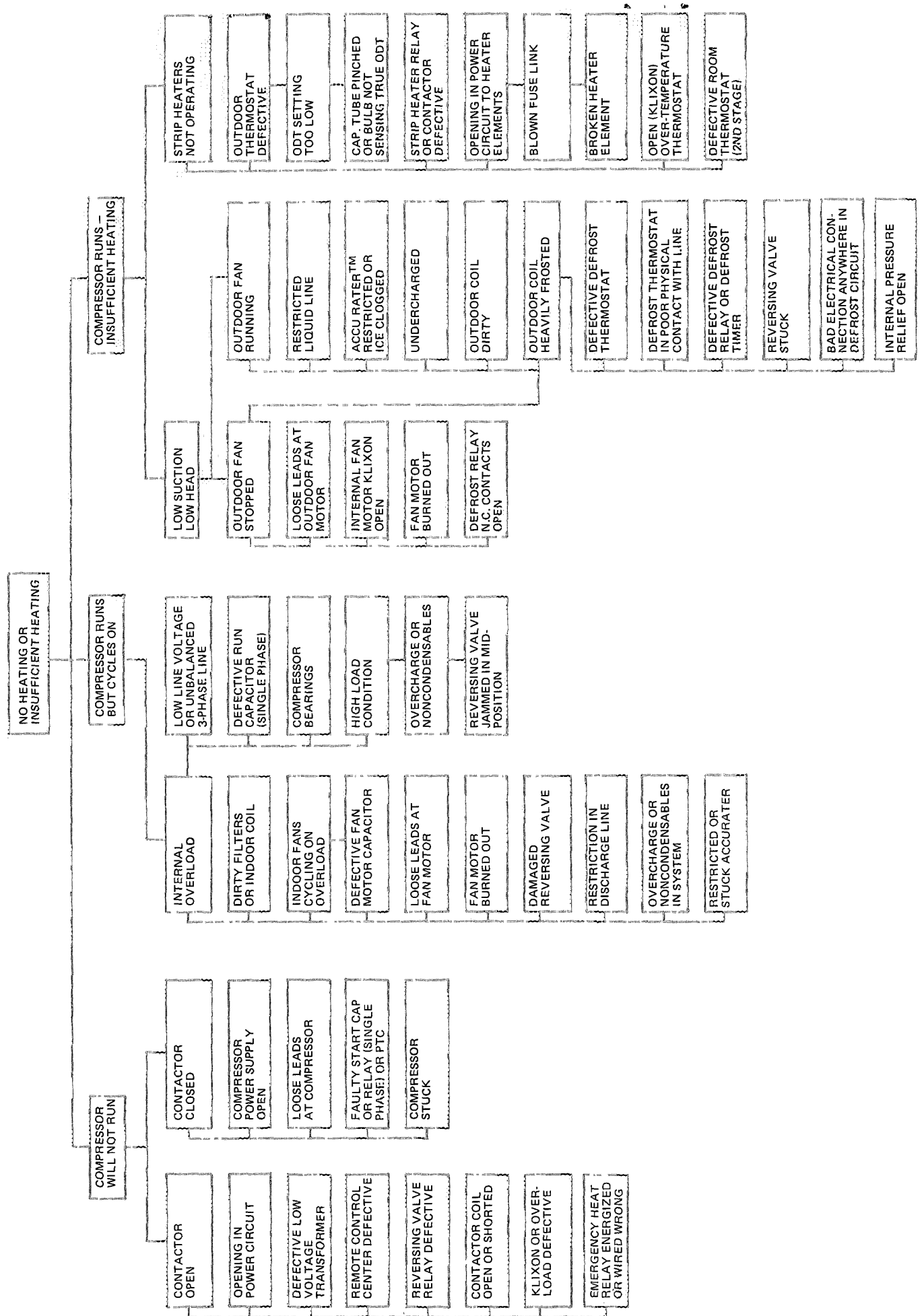

For replacement items use Carrier Specified Parts.

Manufacturer reserves the right to discontinue, or change at any time, specifications or designs without notice and without incurring obligations.

Book	1	4
Tab	5a	5a