

# USER MANUAL

---

## MODEL 1060

AC Powered, Asynchronous  
Short Range Modem



---

**PATTON**  
**Electronics Co.**



An ISO-9001  
Certified Company

Part #07M1060-D  
Doc. #058011UD  
Revised 08/12/99

SALES OFFICE  
(301) 975-1000  
TECHNICAL SUPPORT  
(301) 975-1007  
<http://www.patton.com>

## 1.0 WARRANTY INFORMATION

**Patton Electronics** warrants all Model 1060 components to be free from defects, and will—at our option—repair or replace the product should it fail within one year from the first date of shipment.

This warranty is limited to defects in workmanship or materials, and does not cover customer damage, abuse or unauthorized modification. If this product fails or does not perform as warranted, your sole recourse shall be repair or replacement as described above. Under no condition shall **Patton Electronics** be liable for any damages incurred by the use of this product. These damages include, but are not limited to, the following: lost profits, lost savings and incidental or consequential damages arising from the use of or inability to use this product.

**Patton Electronics** specifically disclaims all other warranties, expressed or implied, and the installation or use of this product shall be deemed an acceptance of these terms by the user.

### 1.1 RADIO AND TV INTERFERENCE

The Model 1060 generates and uses radio frequency energy, and if not installed and used properly—that is, in strict accordance with the manufacturer's instructions—may cause interference to radio and television reception. The Model 1060 has been tested and found to comply with the limits for a Class A computing device in accordance with the specifications in Subpart J of Part 15 of FCC rules, which are designed to provide reasonable protection from such interference in a commercial installation. However, there is no guarantee that interference will not occur in a particular installation. If the Model 1060 does cause interference to radio or television reception, which can be determined by disconnecting the RS-232 interface, the user is encouraged to try to correct the interference by one or more of the following measures: moving the computing equipment away from the receiver, re-orienting the receiving antenna, and/or plugging the receiving equipment into a different AC outlet (such that the computing equipment and receiver are on different branches).

### 1.2 CE NOTICE

The CE symbol on your Patton Electronics equipment indicates that it is in compliance with the Electromagnetic Compatibility (EMC) directive and the Low Voltage Directive (LVD) of the Union European (EU). A Certificate of Compliance is available by contacting Technical Support.

## 1.3 SERVICE

All warranty and non-warranty repairs must be returned freight prepaid and insured to Patton Electronics. All returns must have a Return Materials Authorization number on the outside of the shipping container. This number may be obtained from Patton Electronics Technical Service at:

Tel: **(301) 975-1007**  
Email: **support@patton.com**  
www: **http://www.patton.com**

**NOTE: Packages received without an RMA number will not be accepted.**

Patton Electronics' technical staff is also available to answer any questions that might arise concerning the installation or use of your Model 1060. Technical Service hours: **8AM to 5PM EST, Monday through Friday.**

## 2.0 GENERAL INFORMATION

Thank you for your purchase of this Patton Electronics product. This product has been thoroughly inspected and tested and is warranted for One Year parts and labor. If any questions or problems arise during installation or use of this product, please do not hesitate to contact Patton Electronics Technical Support at (301) 975-1007.

### 2.1 FEATURES

- Data rates to 115.2 Kbps
- Built-in optical isolation & high speed surge protection
- Distances up to 14 miles (19 AWG TWP @ 1200 bps)
- Tri-state LED indicators
- Point-to-point or multipoint
- Local and remote loopback test modes
- DCE/DTE switch selectable
- Hardware and software flow control support
- Externally powered
- Made in the U.S. A.

### 2.2 DESCRIPTION

The **Model 1060 Series asynchronous short range modem** is equipped with a virtual wish list of "bells and whistles": Point-to-point or multipoint applications are supported. Two separate control signals may be passed (one each way), each with switch-selectable pin assignments. Data lines are protected from ground loops and electrically volatile environments by optical isolation and Silicon Avalanche Diodes. System integrity can be evaluated using two built-in test modes: local analog loopback and remote analog loopback. Tri-state LEDs monitor transmit data, receive data and control signals. Finally, 4-wire connections may be made using either RJ-11 jack or terminal blocks—both are included.

In addition, the Model 1060 is perfect for low power RS-232 environments. The new Model 1060 is AC powered, and therefore is the recommended solution for RS-232 environments whose interface voltages are below RS-232 specifications. The Model 1060 supports data rates to 115.2 Kbps and extends RS-232 transmission distances up to 14 miles over two twisted pair.

The Model 1060 is housed in a sturdy metal case and comes with either 115 or 220V external transformers. This is the top-of-the-line in asynchronous short range modems.

## 3.0 CONFIGURATION

The Model 1060 features externally accessible configuration switches, located on the underside of the unit; there is no need to open the case to configure the Model 1060. Figure 1 (below) shows the location of the DIP switch set, as well as the two DCE/DTE switches.

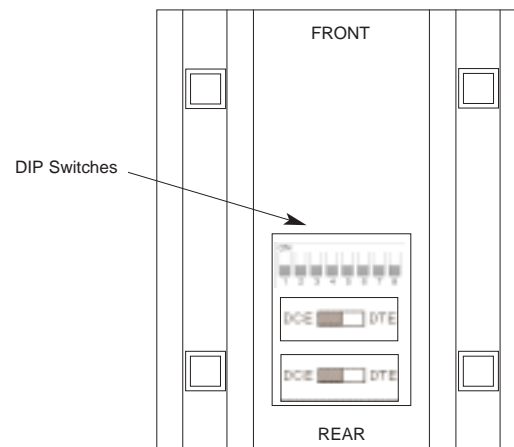

Figure 1. Switch locations underneath Model 1060

### 3.1 "QUICK SET-UP" INSTRUCTIONS

In the majority of applications, you won't need an in-depth knowledge of the Model 1060's capabilities to get up and running. The following "quick set-up" DIP switch configurations cover most Model 1060 operating environments. (Note: DIP switch 8 not used)

#### 3.1.1 POINT-TO-POINT CONFIGURATION

If you are installing these units in a point-to-point application with a computer, printer or terminal, configure the DIP switches on both Model 1060s as follows:

Switch Number:	1	2	3	4	5	6	7
Positions	OFF	OFF	OFF	ON	ON	ON	OFF

### 3.1.2 MULTIPOINT CONFIGURATION

The Model 1060 supports multipoint operation in either daisy chain or star configurations. For multipoint configuration and wiring information, refer to Section 4.2, page 9.

### 3.2 DCE/DTE SWITCH SETTINGS

Correct setting of the DCE/DTE switches eliminates the need for RS-232 crossover cables. If the RS-232 device you are connecting to the Model 1060 is a PC, terminal or host, or is wired like one, set *both* of the DCE/DTE switches to "DCE". If the RS-232 device you are connecting to the Model 1060 is a modem or multiplexer, or is wired like one, set *both* of the DCE/DTE switches to "DTE".

### 3.3 SPECIAL CONFIGURATION

If your installation requires special configuration of the Model 1060, use Table 1 (below) as a guide. This table shows all of the possible Model 1060 switch settings. Following the table are brief descriptions of the Control Input, Control Output, +Voltage Output and Carrier Controlled by (C<sub>in</sub>) parameters shown in the table below.

Mode (DCE/DTE)	Control Input (C <sub>in</sub> )	Control Output (C <sub>out</sub> )	+Voltage Output (V <sub>out</sub> )	Carrier Controlled by (C <sub>in</sub> )	Switch Settings						
					1	2	3	4	5	6	7
DCE	4	8	6	Disabled	<b>ON</b>	<b>ON</b>	<b>ON</b>	<b>OFF</b>	<b>OFF</b>	<b>OFF</b>	<b>OFF</b>
DCE	4	8	6	Enabled	ON	ON	ON	OFF	OFF	OFF	ON
DCE	4,11,20*	8	6	Disabled	OFF	ON	ON	ON	OFF	OFF	OFF
DCE	4,11,20*	8	6	Enabled	OFF	ON	ON	ON	OFF	OFF	ON
DCE	4	6	8	Disabled	ON	OFF	OFF	OFF	ON	ON	OFF
DCE	4	6	8	Enabled	ON	OFF	OFF	OFF	ON	ON	ON
DCE	4,11,20*	6	8	Disabled	OFF	OFF	OFF	ON	ON	ON	OFF
DCE	4,11,20*	6	8	Enabled	OFF	OFF	OFF	ON	ON	ON	ON
DTE	8	4	11,20**	Disabled	ON	ON	ON	OFF	OFF	OFF	OFF
DTE	8	4	11,20**	Enabled	ON	ON	ON	OFF	OFF	OFF	ON
DTE	5,6,8*	4	11,20**	Disabled	OFF	ON	ON	ON	OFF	OFF	OFF
DTE	5,6,8*	4	11,20**	Enabled	OFF	ON	ON	ON	OFF	OFF	ON
DTE	8	11,20**	4	Disabled	ON	OFF	OFF	OFF	ON	ON	OFF
DTE	8	11,20**	4	Enabled	ON	OFF	OFF	OFF	ON	ON	ON
DTE	5,6,8*	11,20**	4	Disabled	OFF	OFF	OFF	ON	ON	ON	OFF
DTE	5,6,8*	11,20**	4	Enabled	OFF	OFF	OFF	ON	ON	ON	ON

\*Multiple input pins are "or-tied"—if any input goes low, carrier is dropped

\*\*Multiple output pins generate the same signal simultaneously

**NOTE:** Default settings are shown in *bold italics*.

**Table 1.** All possible switch settings for the Model 1060

### Control Input (C<sub>in</sub>):

The Control Input signal is used by the local Model 1060 as an input signal to activate its transmitter ("Enabled" settings) and allow data transmission to the remote device. This is required for half-duplex/ switched-carrier environments as well as in hardware flow control applications. In the "Disabled" settings, the 1060 is always "turned on" and sends a continuous carrier to the remote 1060.

### Control Output (C<sub>out</sub>):

The Control Output signal is transmitted by the local Model 1060 to its attached DTE device. This signal should be the same logic state as the Control Input signal on the remote 1060. This signal is required in half-duplex/switched carrier environments or in hardware flow control applications.

### +Voltage Output (+V<sub>out</sub>):

The +Voltage Output signal is a constant positive voltage that is sent from the 1060 to its attached DTE device.

### Carrier Controlled by (C<sub>in</sub>):

When Carrier Controlled by Control Input is "Enabled", the Model 1060's transmitter is activated by the corresponding C<sub>in</sub> Signal from the DTE. In effect, the Control Input signal on the local 1060 "controls" the presence of "carrier" and the Control Output signal on the remote 1060. This setting is required in half-duplex/switched carrier environments or in hardware flow control applications. When Carrier Control by Control Input is "Disabled", the 1060 sends a continuous carrier and is always "turned on".

## 4.0 INSTALLATION

The Model 1060 is easy to install. After configuring the DIP switches and DCE/DTE switches, connect the two twisted pairs using one of two methods: terminal blocks or RJ-11 jack. Figure 2 (below) shows the location of the terminal blocks and RJ-11 jack, as well as the female DB-25, on the rear of the Model 1060.

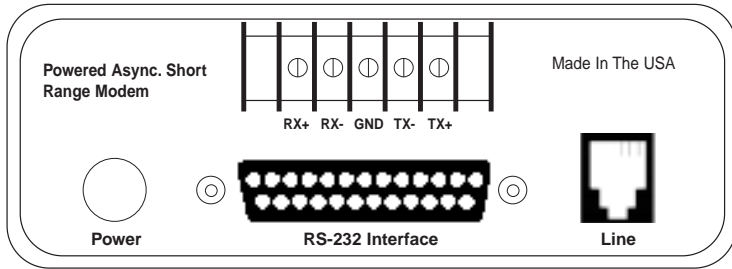

Figure 2. Rear view of 1060 showing interface connectors

### 4.1 TWISTED PAIR WIRING OVERVIEW

These short range modems are designed to work in *pairs*. You will need one at each end of a 4-wire twisted pair circuit. The pairs must be "dry" (unconditioned) metallic wire, 19 - 26 AWG. The smaller gauges limit distance somewhat compared with larger gauges. When you have completed wiring for your data circuit, the pin connections should be as shown below:

XMT + .....	RCV+ .....	} One Pair
XMT - .....	RCV - .....	
G .....	To Shield (Optional)	G
RCV - .....	XMT - .....	} One Pair
RCV + .....	XMT + .....	

#### 4.1.1 TWISTED PAIR CONNECTION USING TERMINAL BLOCKS

If your two twisted pair line terminates in bare wires, strip the ends and connect the individual leads to each Model 1060's terminal block. Be sure the end-to-end connections follow the diagram above.

#### 4.1.2 TWISTED PAIR CONNECTION USING RJ-11

If your two-pair cable is terminated in an RJ-11 plug, you may use the RJ-11 jack in the back of the Model 1060 to make the connection. The RJ-11 jack on a Model 1060 series Short Range Modem is prewired for a standard TELCO wiring environment. To be sure you have the right wiring, use the diagram below as a guide.

<u>RJ-11</u>	<u>SIGNAL</u>
1.....	GND†
2.....	RCV-
3.....	XMT+
4.....	XMT-
5.....	RCV+
6.....	GND†

For proper signal crossing between two Model 1060s using RJ-11 connectors, pin-out the twisted pair cable according to the diagram below.

<u>SIGNAL</u>	<u>PIN#</u>	<u>PIN#</u>	<u>SIGNAL</u>
GND† .....	1.....	6.....	GND†
RCV- .....	2.....	4.....	XMT-
XMT+ .....	3.....	5.....	RCV+
XMT- .....	4.....	2.....	RCV-
RCV+ .....	5.....	3.....	XMT+
GND† .....	6.....	1.....	GND†

†Connection to ground is optional

‡Standard color codes—yours may be different



- 1 - Blue
- 2 - Yellow
- 3 - Green
- 4 - Red
- 5 - Black
- 6 - White

AT&T standard modular color codes

## 4.2 WIRING FOR MULTIPOINT CIRCUITS

The Model 1060 supports multi-point applications using either a star or daisy chain topology. Both topologies require special wiring, as well as specific DIP switch settings for master and slave units.

### 4.2.1 DAISY CHAIN TOPOLOGY

Using a daisy chain topology, you may connect as many as 10 Model 1060s together in a master/slave arrangement. Maximum distance between the units will vary based upon the number of drops, data rate, wire gauge, etc. Call Patton Technical Support for specific distance estimates.

Figure 3 (below) shows how to wire the two-pair cables properly for a Model 1060 daisy chain topology. Note that the ground connection is not needed.

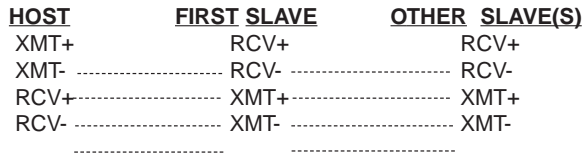

Figure 3. Model 1060 daisy chain wiring

In a multipoint topology, you must configure the master Model 1060's DIP switches differently than those of the slave Model 1060(s). Here are the proper DIP switch settings for a daisy chain topology:

<u>Switch Number</u>	<u>1</u>	<u>2</u>	<u>3</u>	<u>4</u>	<u>5</u>	<u>6</u>	<u>7</u>
Master Positions	ON	ON	ON	OFF	OFF	OFF	OFF
Slave Positions	ON	ON	ON	OFF	OFF	OFF	ON

### 4.2.2 STAR TOPOLOGY

Using a star topology, you may connect several Model 1060s together in a master/slave arrangement. Maximum distance between the units will vary based upon the number of drops, data rate, wire gauge, etc. Call Patton Technical Support for specific distance estimates.

Figure 4 (below) shows how to wire the two-pair cables properly for a Model 1060 star topology. Note that the ground connection is not needed.

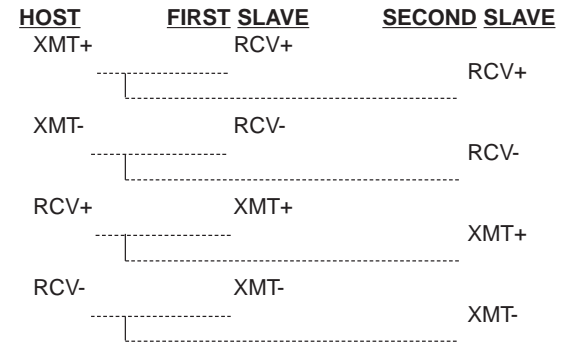

Figure 4. Model 1060 star wiring

In a multipoint topology, you must configure the master Model 1060's DIP switches differently than those of the slave Model 1060(s). Here are the proper DIP switch settings for a star topology:

<u>Switch Number</u>	<u>1</u>	<u>2</u>	<u>3</u>	<u>4</u>	<u>5</u>	<u>6</u>	<u>7</u>
Master Positions	ON	ON	ON	OFF	OFF	OFF	OFF
Slave Positions	ON	ON	ON	OFF	OFF	OFF	ON

## 4.3 RS-232 CONNECTION

To connect the Model 1060 to a piece of data terminal or data communications hardware, use a *straight through* RS-232 cable. Plug the cable directly into the DB-25 port on the rear of the Model 1060. The DCE/DTE switches eliminate the need for a crossover cable.

## 5.0 OPERATION

Once you have configured each Model 1060 properly and connected it, simply plug in the AC power adapter to get it running; there is no power switch on the Model 1060. You can monitor the operation of the Model 1060 using the front panel LED indicators and built-in loopback test modes.

### 5.1 LED INDICATORS

The Model 1060 incorporates six front panel LEDs that show the status of the modem:

1. The **power** LED glows when AC power is applied to the modem.
2. The **loopback test** LED glows when the loopback test switch has been depressed and is in a test mode.
3. The tri-state **TD** and **RD** indicators blink red and green with data activity. Solid red indicates a low RS-232 logic level and no color indicates no activity on the line. Note: RS-232 devices idle in a low state, so the LED will glow red if the connections are correct and the RS-232 device is in an idle state.
4. The **control in** and **control out** indicators glow red for a "low" signal and green for a "high" signal. The specific pin number associated with these indicators will vary according to the switch settings you have selected (see Section 3.0 Configuration).

### 5.2 LOOPBACK TEST MODES

Select the test modes by depressing the "Loopback Test" switch. When in loopback mode, the "Loopback Test" LED will glow red. Two tests are possible using this switch: Local Analog Loop (LAL), and Remote Analog Loop (RAL).

#### 5.2.1 Local Analog Loop

The first test mode is Local Analog Loop (V.54 Loop 3). Any data sent to the local Model 1060 in this mode will be echoed (returned) back to the user device. For example, characters typed on the keyboard of a terminal will appear on the terminal screen (see figure 5 on the following page).

#### 5.2.2 REMOTE ANALOG LOOP

The second test mode is the Remote Analog Loop. To enter this mode, set one of the Model 1060s (local) in test mode by depressing the "Loopback" switch. Any characters sent from the remote 1060 will be returned to it (see figure 5). If no characters are echoed back, check the wiring between the two Model 1060s. Be sure to wire the units according to the instructions in Section 4.0.

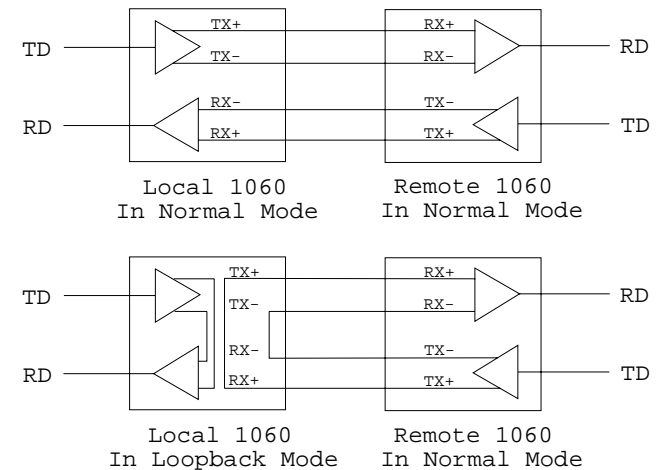

Figure 5. Loopback Test Modes

## APPENDIX A

### PATTON ELECTRONICS MODEL 1060 SPECIFICATIONS

<b>Transmission Format:</b>	Asynchronous
<b>Transmission Line:</b>	19 to 26 AWG twisted pair
<b>Range:</b>	(See table on page 14)
<b>Serial Interface:</b>	EIA RS-232 (CCITT V.24), DB-25 female
<b>Twisted Pair Interface:</b>	Terminal blocks, RJ-11 jack
<b>Data Rates:</b>	0 - 115,200 bps
<b>Applications:</b>	Point-to-point or multipoint
<b>Indicators:</b>	Tri-state for transmit data, receive data, control in, control out; dual-state for power, test
<b>Diagnostics:</b>	Local Analog Loopback (LAL), Remote Analog Loopback (RAL)
<b>Optical Isolation:</b>	2500V RMS (minimum)
<b>Surge Suppression:</b>	Over-voltage protection for opto-isolators via Silicon Avalanche Diodes
<b>Power Supply:</b>	Wall mount, 9-12VAC, 200ma
<b>Temperature Range:</b>	0-60°C (32-140°F)
<b>Altitude:</b>	0-15,000 feet
<b>Humidity:</b>	5 to 95% noncondensing
<b>Dimensions:</b>	4.127"W x 1.52"H x 5.0"L
<b>Weight:</b>	13.2 oz. (without transformer)

## APPENDIX B

### PATTON ELECTRONICS MODEL 1060 CABLE RECOMMENDATIONS

The Patton Model 1060 is designed and tested to communicate over twisted-pair cable with the following characteristics:

<u>Wire Gauge</u>	<u>Capacitance</u>	<u>Resistance</u>
19 AWG	83nF/mi or 15.72 pF/ft.	.0163 /ft.
22 AWG	83nF/mi or 15.72 pF/ft.	.0326 /ft.
24 AWG	83nF/mi or 15.72 pF/ft.	.05165 /ft.

Using the above characteristics as a baseline, we estimate the distance limitations for the Model 1060 to be as follows.

Data Rate	Wire Gauge		
	19 (.9mm)	22 (.5mm)	24 (.4mm)
115,200	1.8 (2.9)	.75 (1.2)	.38 (.6)
57,600	2.5 (4.0)	1.3 (2.1)	.95 (1.5)
38,400	3.7 (6.0)	1.5 (2.4)	1.33 (2.1)
19,200	4.17 (6.7)	1.9 (3.1)	1.42 (2.3)
9,600	5.41 (8.7)	2.6 (4.2)	2.08 (3.3)
4,800	7.05 (11.3)	3.8 (6.1)	2.84 (4.6)
2,400	11.5 (18.5)	7.0 (11.3)	4.83 (7.8)
1,200	14.0 (22.5)	8.5 (13.7)	5.68 (9.1)

To reduce the potential of difficulties in the field, we recommend that the cable used to connect the Model 1060s have a capacitance of no greater than 20pF/ft., and that the wire be no thinner than 26 AWG. The Model 1060 is designed to withstand normal environmental noise and conditions. However, other environmental factors too numerous to discuss may affect proper operation. *The distance table above should be used as a general guideline only.*



### APPENDIX C

#### PATTON ELECTRONICS MODEL 1060 INTERFACE PIN ASSIGNMENTS

DIRECTION	STANDARD "DCE" SETTING	DIRECTION
To Model 1060	<p>1- (FG) Frame Ground 2- (TD) Transmit Data 3- (RD) Receive Data 4- (RTS) Request to Send 5- (CTS) Clear to Send 6- (DSR) Data Set Ready 7- (SG) Signal Ground 8- (DCD) Data Carrier Detect</p>	<p>To Model 1060 From Model 1060 To Model 1060 From Model 1060 From Model 1060 From Model 1060 From Model 1060 From Model 1060</p>
	Data Term. Ready (DTR) - 20	To Model 1060
	11-	To Model 1060

DIRECTION	STANDARD "DTE" SETTING	DIRECTION
From Model 1060	<p>1- (FG) Frame Ground 2- (TD) Transmit Data 3- (RD) Receive Data 4- (RTS) Request to Send 5- (CTS) Clear to Send 6- (DSR) Data Set Ready 7- (SG) Signal Ground 8- (DCD) Data Carrier Detect</p>	<p>From Model 1060 To Model 1060 From Model 1060 To Model 1060 To Model 1060 To Model 1060 To Model 1060 To Model 1060</p>
	Data Term. Ready (DTR) - 20	To Model 1060
	11-	From Model 1060

### APPENDIX D

#### PATTON ELECTRONICS MODEL 1060 BLOCK DIAGRAM

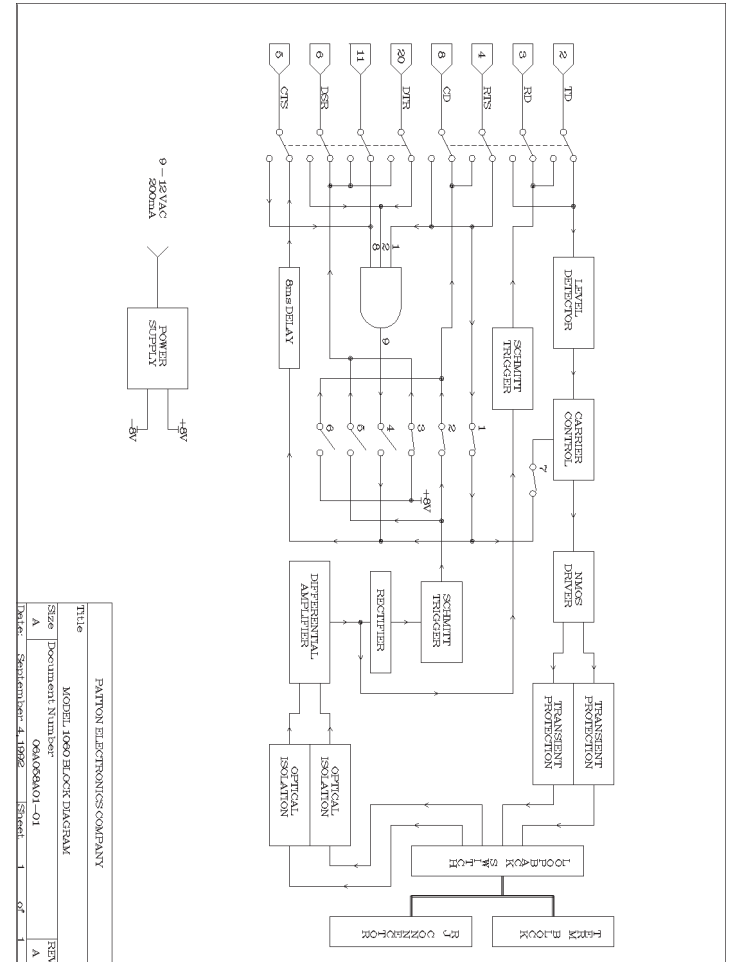

**APPENDIX E**

**TROUBLESHOOTING  
PATTON ELECTRONICS MODEL 1060**

<b>SYMPTOM</b>	<b>PROBLEM</b>	<b>SOLUTION</b>
"TD" and "RD" LEDs indicate activity, but units will not communicate or data is garbled	1. Improper RS-232 wiring	1. Check wiring between Model 1060 and connected serial device—it should be straight through
	2. Improper twisted pair wiring	2. Compare your twisted pair wiring with the diagram in Section 4.1
	3. Improper bit rate setting	3. Make sure the bit rates on all connected serial devices are the same
"TD" and "RD" LEDs indicate activity, but "CD" LED is unlit or red (should be green)	1. Defective twisted pair line	1. Test continuity of twisted pair line
	2. Poor twisted pair connections to Model 1060s	2. Check screw terminal/RJ-11 connections to Model 1060s; check integrity of plug RJ-11 terminations
Occasional data errors		1. Check specifications in Appendix B
	1. Distance/bit rate capacity exceeded	2. Use a different twisted pair circuit if available
	2. Poor quality twisted pair circuit	3. Check screw terminal/RJ-11 connections to Model 1060s; check integrity of plug RJ-11 terminations
	3. Poor twisted pair connections to Model 1060s	

**APPENDIX E  
(continued)**

**TROUBLESHOOTING  
PATTON ELECTRONICS MODEL 1060**

<b>SYMPTOM</b>	<b>PROBLEM</b>	<b>SOLUTION</b>
LEDs do not light when AC power transformer is plugged into wall	1. The AC transformer is not plugged into the Model 1060	1. Have another cup of coffee!
	2. Loose power connection	2. Make sure the AC connection is flush
	3. Outlet is defective	3. Try a different outlet
	4. AC power adapter is defective	4. Call Patton Electronics for a replacement adapter
No data transfer in either or both directions	1. Improper twisted pair wiring	1. Compare your twisted pair wiring with the diagram in Section 4.1
	2. Improper DCE/DTE setting	2. Set both DCE/DTE switches alike, according to the instructions in Section 3.2
	3. Improper bit rate setting	3. Be sure all bit rate settings on all connected serial ports are the same
	4. Improper "control input" pin setting	4. The transmitter must be enabled by a specific "control input" pin (refer to Table 1 in Section 3.3)
	5. Distance specifications exceeded	5. Check specifications in Appendix B