

Installation and Start-Up Instructions

SAFETY CONSIDERATIONS

Installing and servicing air conditioning equipment can be hazardous due to system pressure and electrical components. Only trained and qualified service personnel should install or service air conditioning equipment.

Untrained personnel can perform basic maintenance, such as cleaning and replacing filters. All other operations should be performed by trained service personnel. When working on air conditioning equipment, observe precautions in literature and on tags and labels attached to unit.

Follow all safety codes. Wear safety glasses and work gloves. Use quenching cloth for brazing operations. Have fire extinguisher available. Read these instructions *thoroughly*. Consult local building codes and National Electrical Code (NEC) for special installation requirements.

⚠ WARNING

Before installing or servicing unit, always turn off main power to system. There may be more than one disconnect switch. Turn off accessory heater power if applicable. Electrical shock can cause personal injury.

INSTALLATION

Step 1—Check Equipment and Jobsite—Install on a solid, level mounting pad. It is recommended that unit be attached to pad using tiedown bolts. Fasten unit to pad using holes provided in unit mounting feet. See Fig. 1.

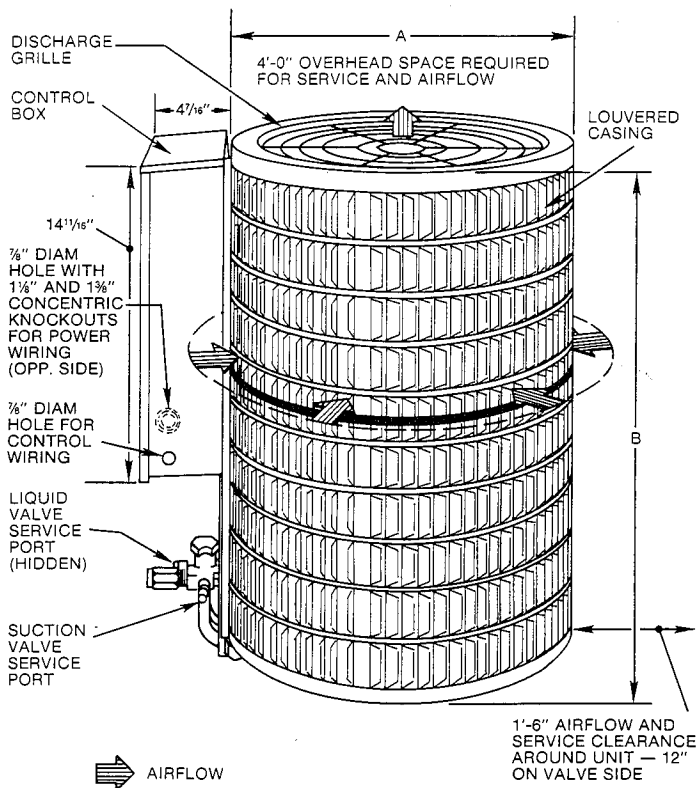

A86167

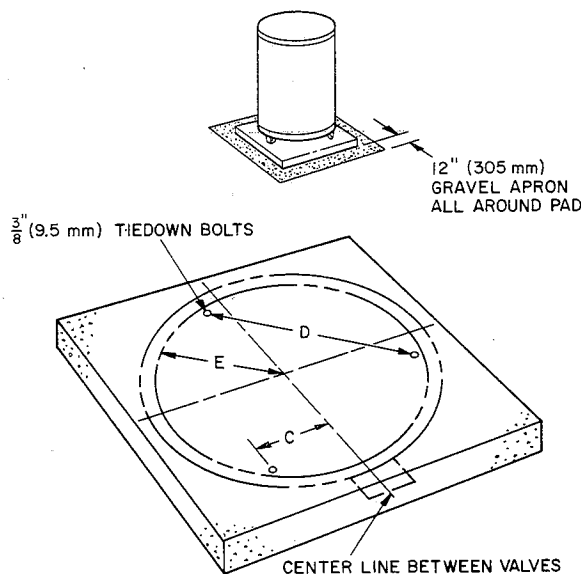

Dimensions (ft.-in.)

Model 38QN	015-030	036-048	060
Diameters	1-9 ¹ / ₂	2-5 ¹ / ₄	3-3
Squares (minimum)	1-11	2-6	3-4
Tiedown Bolt Locations			
C	0-6 ³ / ₄	0-9 ¹ / ₂	1-1 ¹⁵ / ₁₆
D	1-4	1-10 ¹ / ₂	2-7
E	0-9 ¹ / ₄	1-1	1-5 ⁷ / ₈

Fig. 1—Dimensions, Connections and Mounting Pad (Refer to Table 1)

Manufacturer reserves the right to discontinue, or change at any time, specifications or designs without notice and without incurring obligations.

Table 1—Physical Data

MODEL 38QN	015	018	024	030	036	042	048	060
OPER WT (lb)*	132	151	155	180	195	189	235	270
REFRIGERANT	22							
Control	AccuRater™ (Bypass Type)							
COND FAN	Propeller Type, Direct Drive							
Air Discharge	Vertical							
Air Qty (Cfm)	1850		2400		3100	3800	4000	5000
Mtr Rpm (60 Hz)	830		1075		850	1075	840	
COND COIL (fins/in.)	16							
Tube Diam	1/2-in. E-Coil							
Rows			1					2
Refrig Ckts	2		2		2	3		4
Face Area (sq ft)	12.77				17.33			21.88
DIMENSIONS (ft.-in.)								
Diameter	A				2-5/8		3-2/2	
Height	B		1-9/2		2-7			
CONNECT. (in. ODF)	Compatible Fitting (Suction) & Flare (Liquid)							
Suction	%				%			
Liquid			%				%	
REFRIG LINES (in. ODF)								
Suction	%		%		%		1 1/2†	
Liquid			%				%	

*Weight increases slightly with addition of any accessories.

†38QN048-060 require 1 1/8-in. suction line for optimum performance. A 3/4- x 1 1/8-in. connection adapter accessory (Carrier Part No. 28AU900061) is available. If a 7/8-in. accessory tubing package is used, expect a slight capacity loss.

When installing, allow sufficient space for airflow clearance, wiring, refrigerant piping and servicing. Maintain a minimum of 4 ft clearance from obstructions above and 18 in. around unit (12 in. on valve side). Maintain a distance of 24 in. between heat pumps. Position so water or ice from roof or eaves cannot fall directly on unit.

Step 2—Replace Indoor AccuRater™ Piston, if Required— Check indoor coil piston to see if it matches the required piston listed in Table 2. If it does not match, replace indoor coil piston with piston shipped with this outdoor unit (located in plastic bag taped to valves). See Fig. 2.

Table 2—AccuRater™ Chart

OUTDOOR UNIT 38QN	OUTDOOR PISTON	INDOOR PISTON
015	35	46
018	40	49
024	46	59
030	55	65
036	61	73
042	67	73
048	73	82
060	78	101

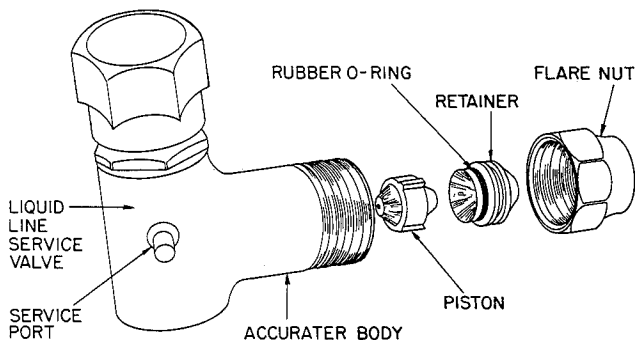

A87151

Fig. 2—AccuRater (Bypass Type) Components

Step 3—Make Piping Connections—Outdoor units may be connected to indoor sections using Carrier accessory tubing package or field-supplied tubing of refrigerant grade, correct size and condition (Table 1). For tubing requirements beyond 50 ft, obtain information from local Carrier distributor.

Outdoor Units Connected to Carrier-Approved Indoor Units—Outdoor units contain correct system refrigerant charge for operation with indoor unit of the same size when connected by 25 ft of field-supplied or Carrier accessory tubing. Check refrigerant charge for maximum efficiency.

⚠ CAUTION

DO NOT BURY MORE THAN 3 FT OF REFRIGERANT TUBING IN GROUND. If any section of tubing is buried, there must be a 6-in. vertical rise to valve connections on outdoor unit. If more than the recommended length is buried, refrigerant may migrate to cooler buried section during extended periods of unit shutdown. This causes refrigerant slugging and possible compressor damage at start-up.

CONNECT REFRIGERANT LINES to fittings on unit suction and liquid service valves (Fig. 1). *Liquid service valve has flare fitting; suction service valve has Compatible Fitting.* Make suction line connection first. Slide flare nut on liquid line, then flare and connect liquid line. Use a maximum torque of 15 ft-lb to tighten flare nut. (Do not disassemble AccuRater.) Unit Compatible Fitting permits mechanical or sweat connection as described below.

Models 38QN048,060—When using 1 1/8 in. field-supplied refrigerant suction line, sweat-connect suction line to 1 1/8 in. end of required connection adapter. Be sure to provide a heat sink at the service valve to prevent damage during sweating operation. Connect 3/4-in. end of adapter to unit suction line Compatible Fitting. Connect liquid refrigerant line to unit. When a 7/8-in. field-supplied suction line is used, provide a field-supplied 3/4-in. to 7/8-in. suction line adapter (not necessary if 38LS accessory tube is used).

NOTE: Compatible Fitting on outdoor section has aluminum plug located beneath compatible nut on suction valve. Plug keeps contaminants out of Compatible Fitting.

⚠ CAUTION

When removing compatible nut, be careful pressure build-up does not cause aluminum plug to blow and cause personal injury. After tubing is hooked up, discard plug.

Mechanical Connection—Mate one set of connections at a time.

1. Remove nut on Compatible Fitting.
2. Remove plug and be sure O-ring is in the groove inside the Compatible Fitting.
3. Cut tubing to correct length. Deburr and size as necessary. Slide nut onto tube.
4. Insert tube into Compatible Fitting until it bottoms. Tighten nut until it bottoms on shoulder of fitting or valve. Keep tube bottomed in Compatible Fitting while tightening nut.

⚠ CAUTION

If undersized, damaged or elliptically-shaped tubing is used when making Compatible Fitting, leaks may result.

Sweat Connection—Use refrigerant grade tubing.

1. Remove locking nut, plug, rubber O-ring and Schrader core and cap from valve service port.
2. Cut tubing to correct length. Deburr and size as necessary.
3. Insert tube in Compatible Fitting until it bottoms.
NOTE: Wrap top and bottom of service valves in wet cloth to prevent damage by heat. Solder with low-temperature (430 F) silver alloy solder.
4. Replace Schrader core and cap.
5. Evacuate or purge system with field-supplied refrigerant.

Compatible Fitting Repair

MECHANICAL CONNECTION—Frontseat unit service valves. Relieve refrigerant pressure from tubing. Back off locknut from Compatible Fitting onto tube. Cut fitting between threads and O-ring. See Fig. 3. Remove tubing section remaining in threaded portion of fitting. Discard locknut.

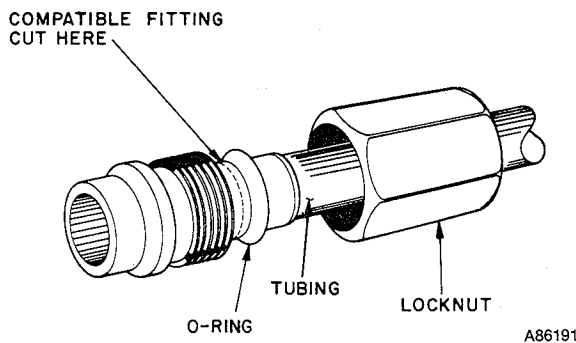

Fig. 3—Repair of Mechanical Connection

Clean, flux and insert new tube end into remaining portion of Compatible Fitting. *Wrap valve in wet rag to prevent damaging factory-made joints.* Heat and apply low-temperature (430 F) solder.

SWEAT CONNECTION—Frontseat unit service valves. Relieve refrigerant pressure from tubing. Clean and flux around leak. Repair, using low-temperature (430 F) solder. Evacuate or purge evaporator coil and tubing system. Add refrigerant charge. See Refrigerant Charging.

Step 4—Make Electrical Connections—Be sure field wiring complies with local and national fire, safety and electrical codes, and voltage to system is within limits shown in Table 3. Contact local power company for correction of improper line voltage.

NOTE: Operation of unit on improper line voltage constitutes abuse and could affect Carrier warranty. See Table 3. Do not install unit in system where voltage may fluctuate above or below permissible limits.

See Table 3 for recommended fuse sizes. When making electrical connections, provide clearance at unit for refrigerant piping connections.

INSTALL BRANCH CIRCUIT DISCONNECT PER NEC of adequate size to handle unit starting current. Locate disconnect within sight from and readily accessible from unit, per Section 440-14 of National Electrical Code (NEC).

ROUTE LINE POWER LEADS—Extend leads from disconnect through power wiring hole provided (see Fig. 1) and into unit splice area. Remove control box cover to gain access to unit wiring.

Table 3—Electrical Data (60 Hz)
Three-phase available with 036-060 sizes

OUTDOOR UNIT 38QN	V/PH	OPER VOLTS*		COMPR		FAN FLA	MCA	MAX FUSE† OR HACR TYPE CKT BKR AMPS
		Max	Min	LRA	RLA			
015-32	208-230/1	253	197	35.0	7.2	0.7	9.7	15
018-33				49.0	10.5	0.7	13.8	20
024-32				53.0	13.2	2.1	18.6	30
030-34				70.0	17.6	1.9	24.1	40
036-31				86.7	18.9	0.9	24.5	40
042-31				108.0	21.8	2.6	29.9	50
048-31				110.0	27.3	1.9	36.0	60
060-31				142.0	33.0	2.1	43.4	60
036-51	208/230/3	254	187	65.0	11.5	0.9	15.3	25
042-51				80.0	13.3	2.5	19.1	30
048-51				92.0	14.7	1.9	20.2	30
060-51				130.0	21.4	2.1	28.9	45
036-61	460/3	506	414	32.8	5.1	1.6	8.0	15
042-61				35.0	7.2	1.6	10.6	15
048-61				46.0	7.0	1.6	10.4	15
060-61				65.0	9.6	1.6	13.9	20

FLA — Full Load Amps
HACR—Heating, Air Conditioning, Refrigeration
LRA — Locked Rotor Amps
MCA — Minimum Circuit Amps
RLA — Rated Load Amps

*Permissible limits of the voltage range at which unit will operate satisfactorily.

†Time-delay fuse.

NOTE: Control circuit is 24 v on all units and requires external power source.

CONNECT GROUND LEAD AND POWER WIRING—Connect ground lead to ground connection in control box for safety. Then connect power wiring. See Fig. 4. Splice line power leads to yellow and black pigtails. Use wire nuts and tape at each connection. Connect unit wiring to *copper* power wiring only.

CONNECT CONTROL POWER WIRING—Route 24-v control wires through control wiring hole and channel and connect leads to control wiring terminal board. See Fig. 1 and 6.

Use furnace or fan coil transformer as 24-v (40-va minimum) supply for system as shown in Fig. 6, or use accessory transformer.

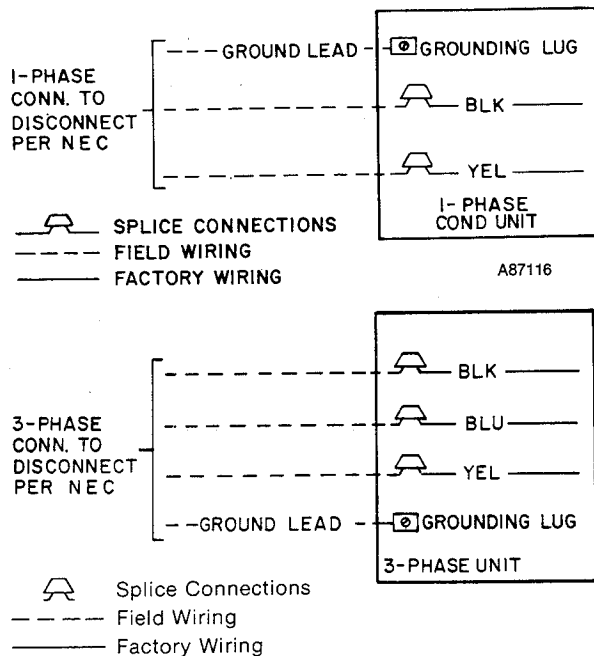

Fig. 4—Line Power Connections

Step 5—Start-Up—Heat Anticipator Settings for Room Thermostat. To set the heat anticipator, move the heat anticipator to the maximum setting. Determine which terminal powers the electric heater controls. With the heaters energized, measure the amperage between the appropriate W terminal and R and set the anticipator to the same value. Fig. 5 illustrates an easy method of obtaining the actual amp draw.

Accessory Outdoor Thermostat provides adjustable outdoor control of accessory electric heater. This thermostat makes contact when a drop in outdoor temperature occurs. It energizes a stage of electric heat when the outdoor temperature setting is reached, provided the room thermostat is on the second stage of heating. One outdoor thermostat is recommended for each stage of electric heat after the first stage. Set the outdoor thermostat(s) progressively lower for each stage. Refer to heat load of building and unit capacity to determine the correct outdoor thermostat settings.

The accessory supplemental heat relay is required when 2 outdoor thermostats are used. It is automatically energized by the manually operated supplemental heat switch in the indoor thermostat subbase. The thermostat locks out compressor and the relay bypasses the outdoor thermostats for electric heater operation during heat pump shutdown. When one outdoor thermostat is used, a supplemental heat relay is not required. The supplemental heat switch in the indoor thermostat subbase bypasses outdoor thermostat, locks out compressor and activates electric heater.

MOUNT OUTDOOR THERMOSTAT in control box. Attach brackets with short sheet metal screws to avoid contact with coil. Leave capillary tube coiled in control compartment making sure it is clear of all electrical connections and sharp metal edges.

MOUNT SUPPLEMENTAL HEAT RELAY in convenient location on indoor unit. Attach with sheet metal screw.

To Start Unit

1. Energize crankcase heater a minimum of 24 hours before starting unit. To energize heater only, set thermostat at OFF position and close electrical disconnect to outdoor unit.
2. Backseat (open) liquid and suction line service valves.



3. Unit is shipped with valve stem(s) frontseated, and caps installed. Replace stem caps after system is opened to refrigerant flow (backseated). Replace caps finger tight and tighten additional 1/8 turn with wrench. See sticker on valve cap.
4. Turn on main disconnect switch(es) to indoor and outdoor units.
5. Set fan switch as desired (ON or AUTO).
6. Set thermostat dial at desired temperature.
7. Set selector switch at HEAT or COOL. Operate unit for 15 minutes.
8. Check system refrigerant charge. See Refrigerant Charging.

Motors and controls are designed to operate satisfactorily in the voltage range shown in Table 3. If necessary to use manifold gages for servicing, refer to Carrier Standard Service Techniques Manual, Chapter 1, Refrigerants, Pages 1-5, Fig. 8 for bypass method of returning charge to system. Removal of liquid line charging hose without following these precautions could result in some loss of charge.

Refrigerant Charging (Fig. 7 through 14)

CAUTION

To prevent personal injury, wear safety glasses and gloves when handling refrigerant. Do not overcharge system. This can cause compressor failure.

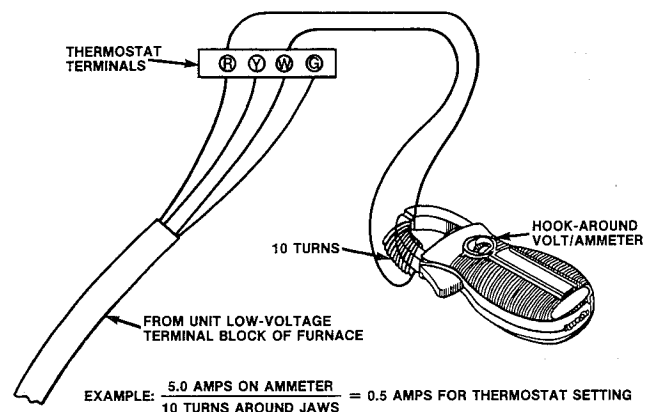
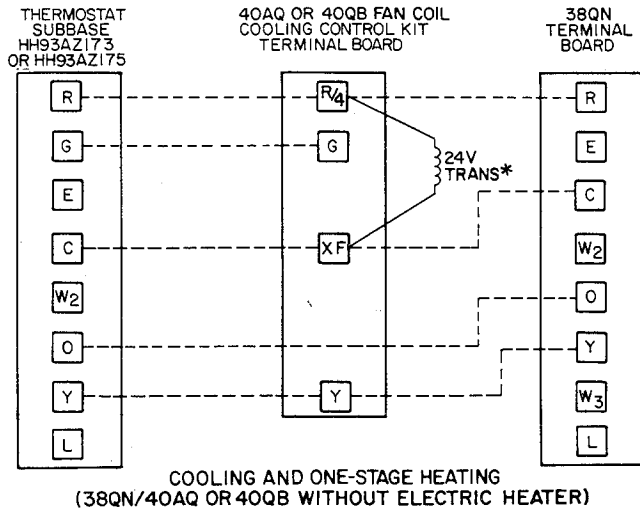
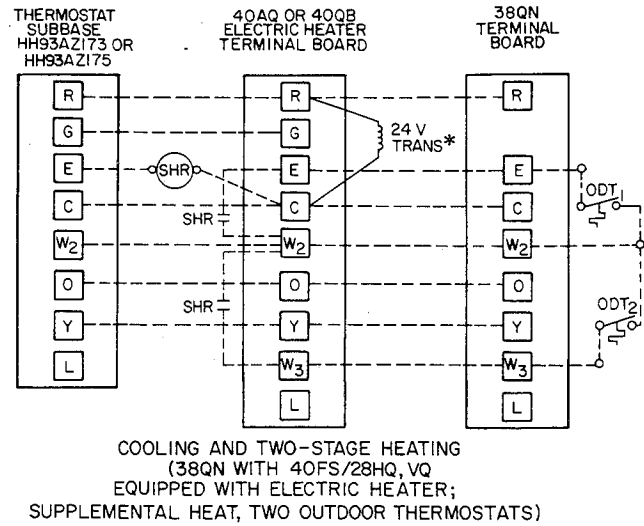

Fig. 5—Determining Amp Draw



A

A87153



D

A87154

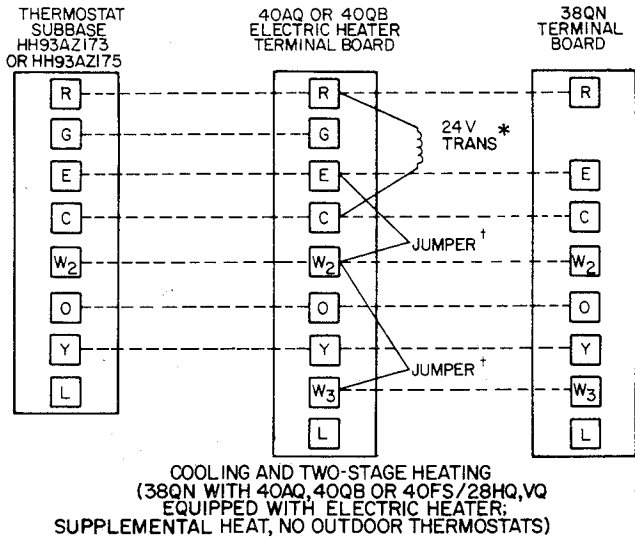

B

A87152

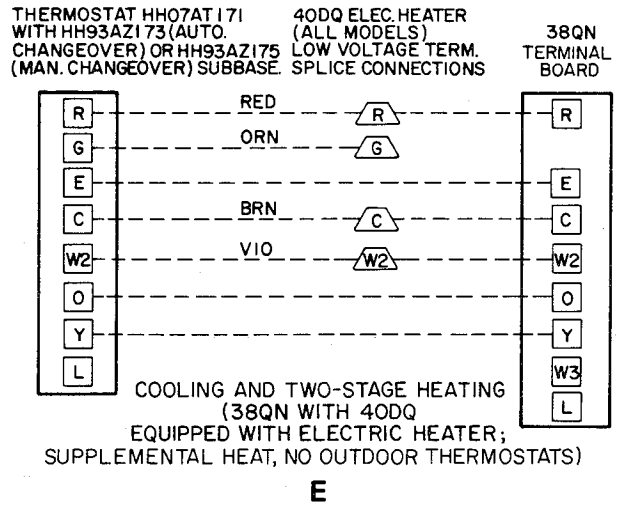

E

A87156

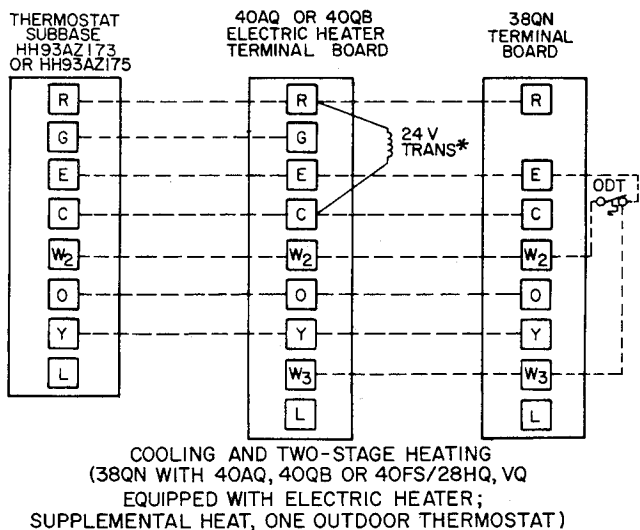

C

A87155

ODT — Outdoor Thermostat
SHR — Supplemental Heat Relay
— Factory Wiring
- - - Field Wiring

*Transformer (60 va) located in cooling control kit or electric heater.

†Remove factory-installed jumper (Connection B) when installing outdoor thermostats (ODT).

Fig. 6—Control Circuit Connections

HEATING CYCLE CHECK CHARTS

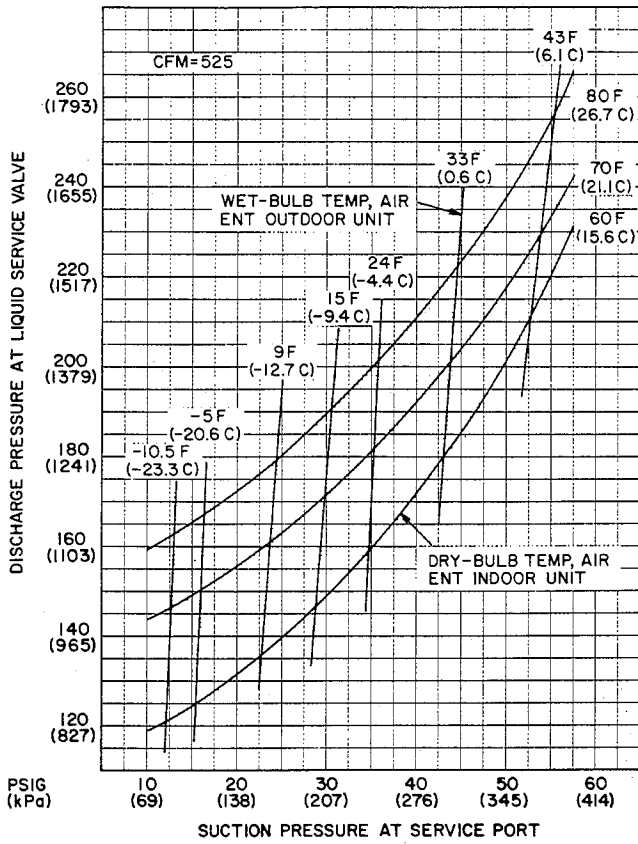
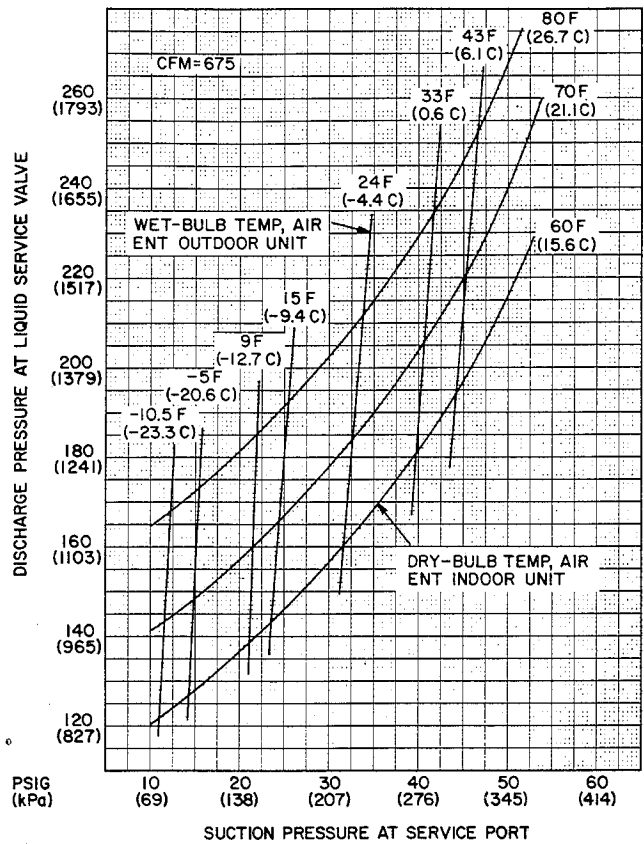
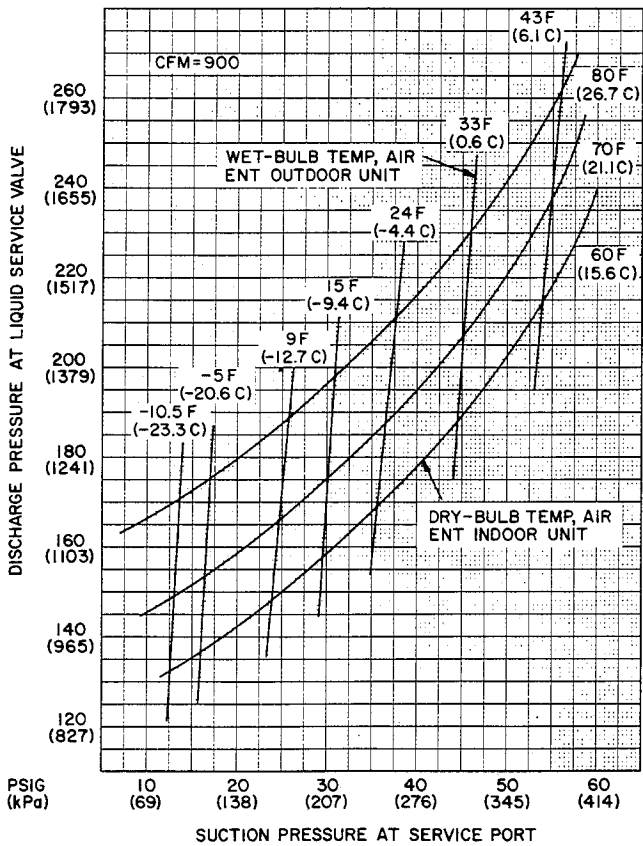

Fig. 7—38QN015 Heating Cycle Check Chart



A87157

Fig. 8—38QN018 Heating Cycle Check Chart



A87158

Fig. 9—38QN024 Heating Cycle Check Chart

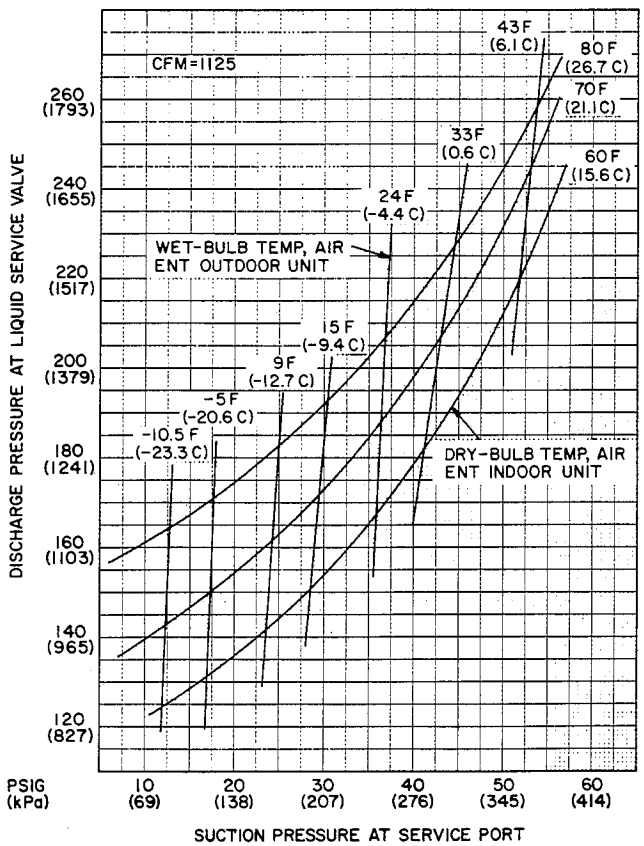

A87159

Fig. 10—38QN030 Heating Cycle Check Chart

HEATING CYCLE CHECK CHARTS (cont)

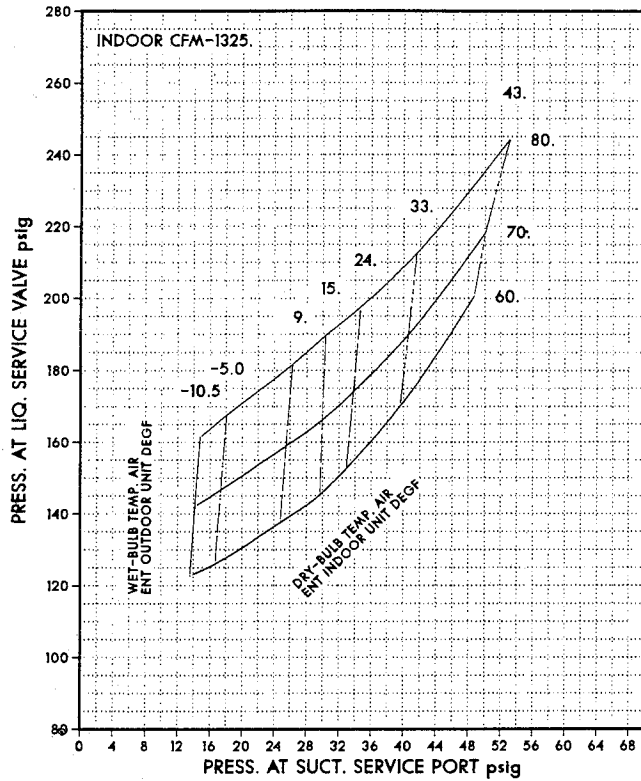

Fig. 11—38QN036 Heating Cycle Check Chart

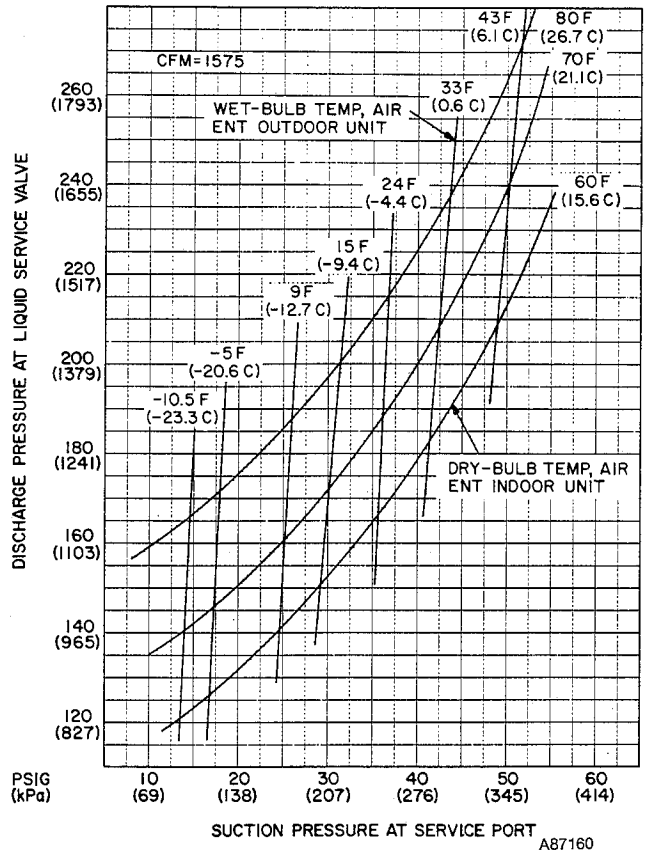

Fig. 12—38QN042 Heating Cycle Check Chart

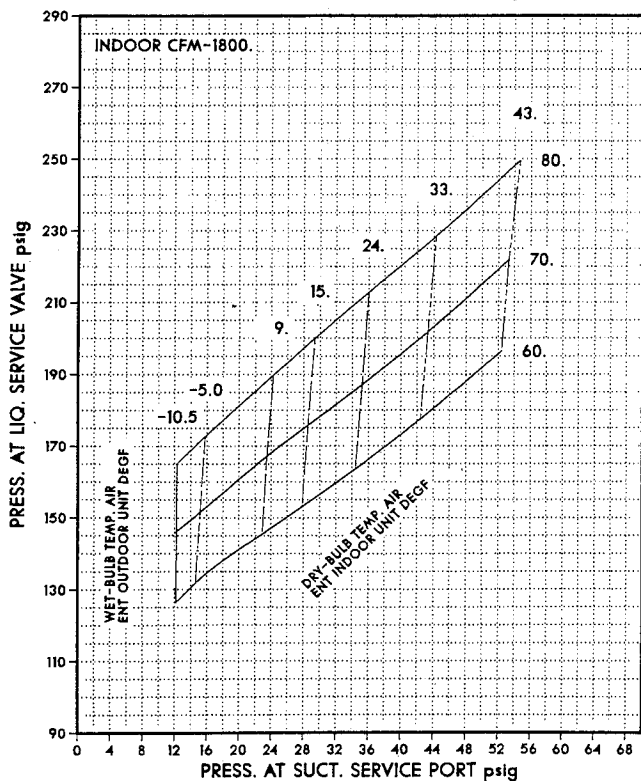

Fig. 13—38QN048 Heating Cycle Check Chart

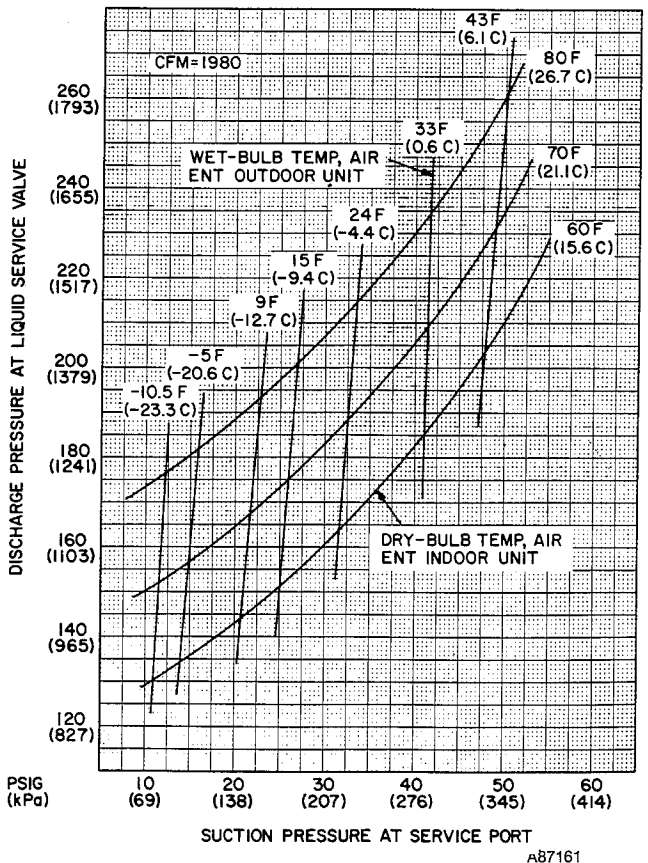

Fig. 14—38QN060 Heating Cycle Check Chart

To check system operation during heating cycle, use correct Heating Cycle Check Chart (Fig. 7 through 14). These charts indicate whether a correct relationship exists between system operating pressure and air temperatures entering indoor and outdoor units. If pressure and temperature lines do not intersect on chart, system refrigerant charge may not be correct or other system abnormalities may exist. Do not use Heating Cycle Check Charts to adjust refrigerant charge.

When recharging is necessary during heating season, weigh in total charge as indicated on unit rating plate. Remove any refrigerant remaining in system before recharging. If the system has lost complete charge, evacuate and recharge by weight. Service port connections are provided on liquid and suction line service valves. For evacuation and recharging, Dial-A-Charge charging cylinder is an accurate device for recharging systems by weight.

To check and adjust charge during cooling season, use Tables 4 and 5 and the following procedure:

1. Operate unit a minimum of 15 minutes before checking charge.
2. Measure suction pressure by attaching a gage to suction valve service port.
3. Measure suction line temperature by attaching a service thermometer to unit suction line near suction valve. Insulate thermometer for accurate readings.
4. Measure outdoor coil inlet air dry-bulb temperature

**Table 4—Superheat Charging Table
(Superheat Entering Suction Service Valve)**

OUTDOOR TEMP (F)	INDOOR COIL ENTERING AIR (F) WB															
	50	52	54	56	58	60	62	64	66	68	70	72	74	76		
55	9	12	14	17	20	23	26	29	32	35	37	40	42	45		
60	7	10	12	15	18	21	24	27	30	33	35	38	40	43		
65	—	6	10	13	16	19	21	24	27	30	33	36	38	41		
70	—	—	7	10	13	16	19	21	24	27	30	33	36	39		
75	—	—	—	6	9	12	15	18	21	24	28	31	34	37		
80	—	—	—	—	5	8	12	15	18	21	25	28	31	35		
85	—	—	—	—	—	—	8	11	15	19	22	26	30	33		
90	—	—	—	—	—	—	—	5	9	13	16	20	24	27	31	
95	—	—	—	—	—	—	—	—	6	10	14	18	22	25	29	
100	—	—	—	—	—	—	—	—	—	8	12	15	20	23	27	
105	—	—	—	—	—	—	—	—	—	—	5	9	13	17	22	26
110	—	—	—	—	—	—	—	—	—	—	—	6	11	15	20	25
115	—	—	—	—	—	—	—	—	—	—	—	—	8	14	18	23

—Do not attempt to charge system under these conditions or refrigerant slugging may occur.

- with a second thermometer.
5. Measure indoor coil inlet air wet-bulb temperature with a sling psychrometer.
 6. Refer to Table 4. Find air temperature entering outdoor coil and wet-bulb temperature entering indoor coil. At this intersection, note the superheat.
 7. Refer to Table 5. Find superheat temperature and suction pressure, and note suction line temperature.
 8. If unit has higher suction line temperature than charted temperature, add refrigerant until charted temperature is reached.
 9. If unit has lower suction line temperature than charted temperature, bleed refrigerant until charted temperature is reached.
 10. If air temperature entering outdoor coil or pressure at suction valve changes, charge to new suction line temperature indicated on chart.
 11. This procedure is valid, independent of indoor air quantity.

NOTE: For service data, refer to separate service manual for Models 38EH,EN,ES,QH,QN,QS.

**Table 5—Required Suction-Tube Temperature (F)
(Entering Suction Service Valve)**

SUPERHEAT TEMP (F)	SUCTION PRESSURE AT SERVICE PORT (psig)								
	61.5	64.2	67.1	70.0	73.0	76.0	79.2	82.4	85.7
0	35	37	39	41	43	45	47	49	51
2	37	39	41	43	45	47	49	51	53
4	39	41	43	45	47	49	51	53	55
6	41	43	45	47	49	51	53	55	57
8	43	45	47	49	51	53	55	57	59
10	45	47	49	51	53	55	57	59	61
12	47	49	51	53	55	57	59	61	63
14	49	51	53	55	57	59	61	63	65
16	51	53	55	57	59	61	63	65	67
18	53	55	57	59	61	63	65	67	69
20	55	57	59	61	63	65	67	69	71
22	57	59	61	63	65	67	69	71	73
24	59	61	63	65	67	69	71	73	75
26	61	63	65	67	69	71	73	75	77
28	63	65	67	69	71	73	75	77	79
30	65	67	69	71	73	75	77	79	81
32	67	69	71	73	75	77	79	81	83
34	69	71	73	75	77	79	81	83	85
36	71	73	75	77	79	81	83	85	87
38	73	75	77	79	81	83	85	87	89
40	75	77	79	81	83	85	87	89	91