



installation, start-up, and operating instructions

ICM FIOP INSTALLATION INSTRUCTIONS

583B
683B
602B
702B

Cancels: II 583B-24-2

II 583B-24-3
11-01

NOTE: Read the entire instruction manual before starting the installation.

TABLE OF CONTENTS

SAFETY CONSIDERATIONS	1
INTRODUCTION	2
RECEIVING AND INSTALLATION	2
ICM FIOP PRE-START-UP.....	2
Electrical Connections	2
Control Voltage Connections.....	2
Standard Connection.....	2
Easy Select™—583B	2
583B Sequence of Operation	4
Easy Select™—683B	5
683B Sequence of Operation	7
Easy Select™—702B & 602B.....	7
702B & 602B Sequence Of Operation.....	9
ICM FIOP START-UP	10
583B Start-Up (ICM FIOP).....	10
683B Start-Up (ICM FIOP).....	10
702B: Start-Up (ICM FIOP)	11
602B: Start-Up (ICM FIOP)	11
ELECTRICAL DATA & SCHEMATICS—ICM FIOP.....	12
Physical Data & Electrical Schematics.....	12
Tables For System Set-Up.....	12
CARE AND MAINTENANCE	12
TROUBLESHOOTING	13
START-UP CHECKLIST.....	13

NOTE TO INSTALLER — READ THESE INSTRUCTIONS CAREFULLY AND COMPLETELY before installing this unit. Also, make sure the Owner's Manual and Service Instructions are left with the unit after installation.

SAFETY CONSIDERATIONS

Installation and servicing of air-conditioning equipment can be hazardous due to system pressure and electrical components. Only trained and qualified personnel should install, repair, or service air-conditioning equipment.

Untrained personnel can perform basic maintenance functions of cleaning coils and filters. All other operations should be performed by trained service personnel. When working on air-conditioning equipment, observe precautions in the literature, tags, and labels attached to the unit, and other safety precautions that may apply.

Follow all safety codes. Wear safety glasses and work gloves. Use quenching cloth for unbrazing operations. Have fire extinguisher available for all brazing operations.

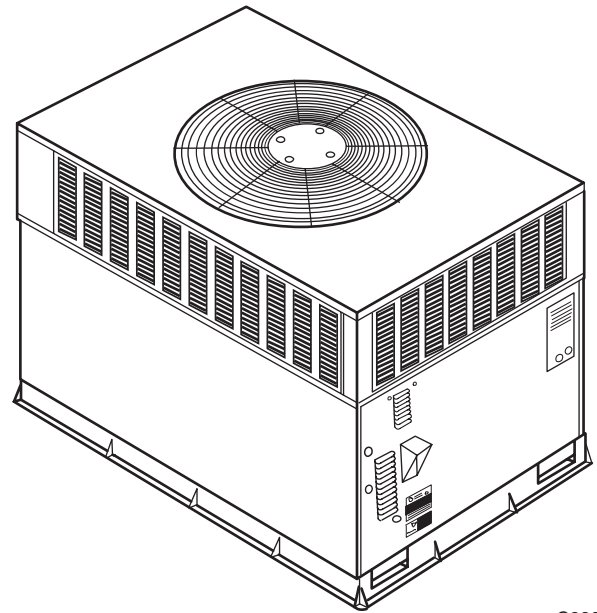

C99087

Fig. 1—Puron® Unit (583B Shown)

WARNING: Improper installation, adjustment, alteration, service, maintenance, or use can cause explosion, fire, electric shock, or other occurrences, which could cause serious injury or death or damage your property. Consult a qualified installer or service agency for information or assistance. The qualified installer or agency must use only factory-authorized kits or accessories when modifying this product.

Recognize safety information. This is the safety-alert symbol . When you see this symbol on the product or in instructions or manuals, be alert to the potential for personal injury.

Understand the signal words — DANGER, WARNING, CAUTION, and NOTE. Danger identifies the most serious hazards, which **will** result in severe personal injury or death. Warning indicates a condition that **could** cause serious personal injury or death. Caution is used to identify unsafe practices, which **would** result in minor personal injury or product and property damage. NOTE is used to highlight suggestions which **will** result in enhanced installation, reliability, or operation.

The power supply (volts, phase, and hertz) must correspond to that specified on unit rating plate.

The electrical supply provided by the utility must be sufficient to handle load imposed by this unit. Electrical supply must match the voltage requirements listed on unit rating plate.

This installation must conform with local building codes and with NEC (National Electrical Code). Refer to provincial and local plumbing or waste water codes and other applicable local codes. Approved for outdoor installation on wood flooring or on class A, B or C roof covering materials.

WARNING: Before performing service or maintenance operations on system, turn off main power to unit and install lock-out tag. Turn off accessory heater power switch if applicable. Electrical shock could cause severe injury or death.

CAUTION: Puron® (R-410A) systems operate at higher pressures than standard R-22 systems. Do not use R-22 service equipment or components on Puron® (R-410A) equipment. Ensure service equipment is rated for Puron® (R-410A)

WARNING: Make sure that the power supply to the unit is switched OFF before making any wiring changes. With disconnect switch open, move yellow wire from transformer (3/16 in.) terminal marked 230 to terminal marked 200. This retaps transformer to primary voltage of 208-v. Electrical shock could cause serious injury or death.

INTRODUCTION

NOTE: The minimum outdoor cooling operating temperature for units using this ICM motor option is 55°F. To operate in cooling at lower ambients the Motor Master™ II low ambient kit is required.

These instructions cover the installation of a Bryant Small Packaged Product with ICM motor-factory installed option (FIOP). This option can be selected as a FIOP on gas heating/electric cooling (583B), dual fuel-electric heat pump with gas heat back-up (683B), electric cooling (702B) or electric heat pump (602B) units with Puron®.

RECEIVING AND INSTALLATION

Refer to unit Installation Instructions.

ICM FIOP PRE-START-UP

I. ELECTRICAL CONNECTIONS

A. Control Voltage Connections

NOTE: Do not use any type of power-stealing thermostat, without connecting the C (Common) terminal. Failure to follow this note could result in unit control problems.

Use no. 18 American Wire Gage (AWG) color-coded, insulated (35 C minimum) wires to make the control voltage connections between the thermostat and the unit. If the thermostat is located more than 100 ft from the unit (as measured along the control voltage wires), use no. 16 AWG color-coded, insulated (35 C minimum) wires.

B. Standard Connection

Remove knockout hole located in the heat section panel adjacent to the service access panel (See unit installation package). Remove the rubber grommet from the installer's packet (included with unit) and install grommet in the knockout opening. Provide a drip loop before running wire through panel. Run the low-voltage leads from the thermostat, through the inlet hole, and into unit low-voltage splice box. Locate 18-gage wires leaving control box. These low-voltage connection leads can be identified by colors (See Fig. 2, 3, 4 or 5). Ensure the leads are long enough to be routed into the low-voltage splice box (located below right side of control box). Route leads through hole in bottom of control box and make low-voltage connections (See Fig. 2, 3, 4 or 5). Secure all cut wires, so that they do not interfere with operation of unit.

SPECIAL PROCEDURES FOR 208-V OPERATION

C. Easy Select™—583B

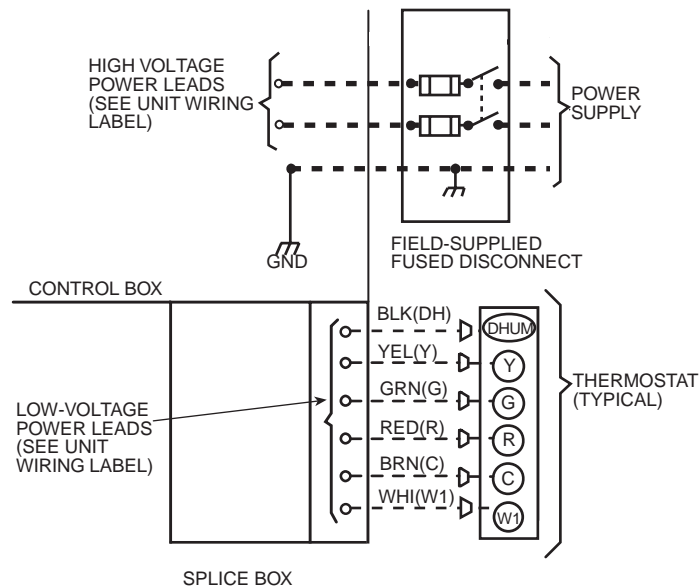

LEGEND

Field Control-Voltage Wiring - - - - -
Field High-Voltage Wiring - - - - -

C01026

Fig. 2—583B High- and Control-Voltage Connections

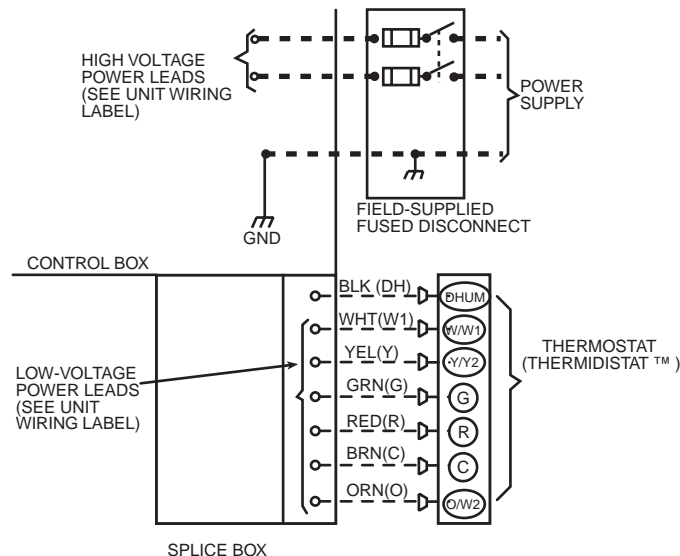

FIELD CONTROL - VOLTAGE WIRING - - - - -
FIELD HIGH - VOLTAGE WIRING - - - - -

C01107

Fig. 3—683B High- and Control-Voltage Connections

EASY SELECT™ CONFIGURATION TAPS FOR 583B
Easy Select™ taps are used by the installer to configure a system. The ICM motor uses the selected taps to modify its operation to a

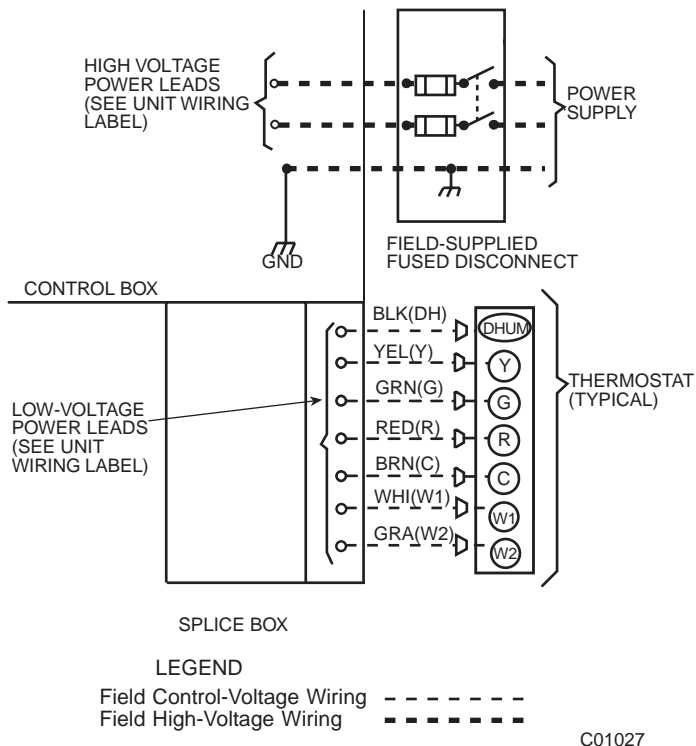

Fig. 4—702B High- and Control-Voltage Connections

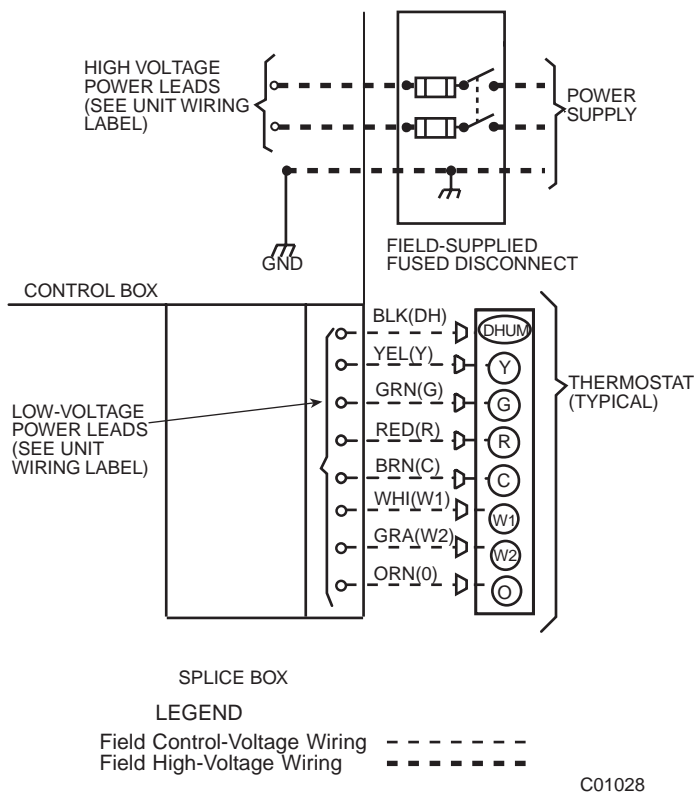

Fig. 5—602B High- and Control-Voltage Connections

pre-programmed table of airflows.

The unit must be configured to operate properly with system components with which it is installed. To successfully configure a basic system (see information printed on circuit board label located next to select pins), move the 6 select wires to the pins which match the components used (See Fig. 8).

a. GAS HEAT/CFM—SELECT GAS HEAT INPUT SIZE

Factory selected gas heat size should correspond to unit label.

b. AC/HP SIZE—SELECT SYSTEM SIZE INSTALLED

Factory selected air conditioner size should correspond to capacity of unit installed. Installer should verify air conditioner size to ensure that airflow delivered falls within proper range for the size unit installed. This applies to all operational modes.

c. SYSTEM TYPE—SELECT SYSTEM TYPE INSTALLED

Factory selected on 583B for AC-Air conditioner.

For Gas Heat/Electric Cool Unit—AC must be selected.

d. AC/HP CFM ADJUST—SELECT NOMINAL, LOW, OR HIGH AIRFLOW

The AC/HP CFM Adjust select is factory set to the High-HI (NOM for 060) tap. The CFM Adjust selections NOM/LO will regulate airflow supplied for all operational modes, except non-heat pump heating modes. HI provides 15 percent airflow over nominal unit size selected and LO provides 10 percent airflow below nominal unit size selected. Adjust selection options are provided to adjust airflow supplied to meet individual installation needs for such things as noise, comfort, and humidity removal (See Fig. 8, D as indicated).

e. ON/OFF DELAY—SELECT DESIRED TIME DELAY PROFILE

Four motor operation delay profiles are provided to customize and enhance system operation (See Fig. 8, E as indicated).

Selection options are:

- (1.) The standard 90 sec off delay (Factory Setting) at 100 percent airflow in cooling mode. In heating mode, IGC will control 45 sec on delay with no airflow and 45 sec off delay.
- (2.) A 30 sec cooling delay with no airflow/ 90 sec off delay at 100 percent airflow profile is used when it is desirable to allow system coils time to cool-down in conjunction with the airflow in heating mode.
- (3.) A no delay option used for servicing unit or when a thermostat is utilized to perform delay functions in cooling mode. In heating mode IGC will control 45 sec on delay with no airflow and 45 sec off delay.
- (4.) Not recommended for 583B

f. CONTINUOUS FAN—SELECT DESIRED FAN SPEED WHEN THERMOSTAT IS SET ON CONTINUOUS FAN

- (1.) LO speed—Factory setting, 50 percent cooling mode airflow.
- (2.) MED speed—Move connector to MED, 65 percent cooling mode airflow.
- (3.) HI speed—Move connector to HI, 100 percent cooling mode airflow (See Fig. 8, F as indicated).

g. LOW-VOLTAGE CIRCUIT FUSING AND REFERENCE

The low-voltage circuit is fused by a board-mounted 5-amp automotive fuse placed in series with the transformer SEC2 and the R circuit. The C circuit of the transformer is referenced to chassis ground through a printed circuit run at SEC1 connected to metal standoff marked with ground symbol.

h. BASIC UNIT CONFIGURATION

The following basic configuration of the indoor motor will provide ARI rated performance of the 583B. *This BASIC CONFIGURATION should be used when the rated ARI performance is required, or if system enhancements such as super dehumidify are not needed.*

- (1.) HEAT—Factory selected to match heat input size.
- (2.) AC/HP Size—Factory selected to match system size, please verify.

- (3.) SYSTEM TYPE—Factory selected on 583B system AC-AIR CONDITIONER.
- (4.) AC/HP CFM ADJUST—Select HIGH for 042 & 048, NOM for 036 & 060, and LO for 024 & 030..
- (5.) ON/OFF DELAY—Factory selected 0/90 profile.
- (6.) CONTINUOUS FAN—Select desired fan speed when thermostat is set to continuous fan.

i. COMFORT OPTIONS—SUPER DEHUMIDIFY (See Quick Reference Guide)

The Super Dehumidify option is possible when this unit is installed with a field supplied Thermidistat™ control (Super-Dehumidify does not require an outdoor temperature sensor). The following configuration is recommended for maximum cooling/dehumidifying comfort. This configuration will improve the comfort provided by the air conditioning system if more humidity removal is desired. While providing this improved comfort, the system will operate efficiently, but not at the published ARI SEER efficiency. During cool-to-dehumidify call, it provides maximum dehumidification by reducing airflow to a minimum. The actual super dehumidify command from Thermidistat™ control to the indoor unit is a “Y” signal without a “G” signal in addition to dehumidify signal. The indoor unit responds to this combination by reducing the airflow to a minimum. All other characteristics of cool to dehumidify are the same.

The following system configuration is recommended for maximum cooling/dehumidifying comfort (See Fig. 8).

- (1.) HEAT—Factory selected to match gas heat size of unit installed.
- (2.) AC/HP Size—Factory selected to match system size, please verify.
- (3.) SYSTEM TYPE—Factory selected on 583B system AC-AIR CONDITIONER.
- (4.) AC/HP CFM ADJUST—Select NOM (Lo for 060).
- (5.) ON/OFF DELAY—Select ENH profile.
- (6.) CONTINUOUS FAN—Select desired fan speed when thermostat is set to continuous fan.
- (7.) DEHUMIDIFY MODE—Remove J1 jumper to activate.

NOTE: J1 jumper should only be removed when a Thermidistat™, humidistat or capable zoning control is installed.

- (8.) LOW VOLTAGE CONNECTIONS—Make connections as shown in ELECTRICAL CONNECTIONS section.
- (9.) CONFIGURE THERMIDISTAT™—Follow Thermidistat™ (or capable zoning system) installation instructions for Super Dehumidify operation.

ACCESSORY INSTALLATION

a. AUXILIARY TERMINALS

The AUX and HUM terminals on the Easy Select™ Board are tied directly to the G terminal, and provide a 24-v. signal whenever the G terminal is energized (See Fig. 6). During Super dehumidify mode, the G signal is not present and the auxiliary terminals are not energized. If the installation includes the use of this operating mode, do not use these terminals to control accessories. See Electronic Air Cleaner and Humidifier sections for further information.

b. ELECTRONIC AIR CLEANER CONNECTIONS

The AUX1 and AUX2 terminals are not always energized during blower operations, as described above. When using an electronic air cleaner with the unit, use Airflow Sensor P/N.

KEAAC0101AAA. The airflow sensor turns on electronic air cleaner when the blower is operating.

c. HUMIDIFIER/HUMIDISTAT CONNECTIONS

Easy Select™ Board terminals HUM1 and HUM2 are provided for direct connection to the low-voltage control of a humidifier through a standard humidistat (See Fig. 6). These terminals are energized with 24-v. when G thermostat signal is present (See Fig. 6 & 7). Alternately, the 24-v. signal may be sourced from the W and C on the 9 pin connector. When using a Thermidistat™ Control, Zone Perfect Plus or Comfort Zone II, the 24-v. signal may be sourced directly from the Thermidistat™ HUM terminal (See Fig. 6, 7 & 8).

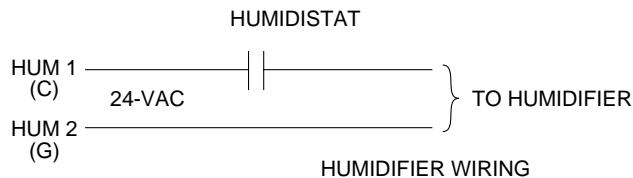

A95317

Fig. 6—Humidifier Wiring-583B

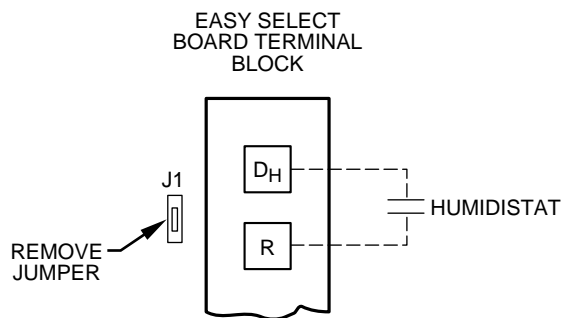

A95316

Fig. 7—Humidistat Wiring for De-Humidify Mode-583B

d. DEHUMIDIFY CAPABILITY WITH STANDARD HUMIDISTAT CONNECTION

Latent capacities for this unit are better than average systems. If increased latent capacity is an application requirement, the ICM board provides connection terminals for use of a standard humidistat. The unit will detect the humidistat contacts opening on increasing humidity and reduce its airflow to approximately 80 percent of nominal cooling mode airflow. This reduction will increase the system latent capacity until the humidity falls to a level which causes the humidistat to close its contacts. When the contacts close, the airflow will return to 100 percent of selected cooling airflow. To activate this mode, remove jumper J1 and wire in a standard humidistat (See Fig. 7).

e. DEHUMIDIFY AND SUPER DEHUMIDIFY CAPABILITIES

This model unit is capable of responding to a signal from indoor system control (Thermidistat™ or capable zoning control) to operate in comfort control modes such as Super Dehumidify Mode. Consult literature provided with indoor system control to determine if these operating modes are available, and to see control set up instructions. No special setup or wiring of unit is required.

D. 583B Sequence of Operation

a. CONTINUOUS FAN

- (1.) Thermostat closes circuit R to G—The Blower runs at continuous fan airflow

b. COOLING MODE

- (1.) If indoor temperature is above temperature set point and humidity is below humidity set point, thermostat closes circuits R to G, R to Y/Y2 and R to O—The unit delivers single speed cooling airflow.

c. COOLING MODE-DEHUMIDIFICATION

- (1.) If indoor temperature is above temperature set point and humidity is above humidity set point, thermostat or Thermidistat™ closes circuits R to G, R to Y/Y2, R to O and humidistat or Thermidistat™ opens R to DH—The unit delivers airflow which is approximately 80 percent of the nominal cooling airflow to increase the latent capacity of the system.

d. COOLING MODE-SUPER DEHUMIDIFY OPERATION (SEE QUICK REFERENCE GUIDE)

NOTE: The indoor control used, such as a Thermidistat™, must be capable of providing Super Dehumidify operation mode and control must be configured as outlined in its installation instructions. Consult indoor control literature to determine if control is capable of providing Super Dehumidify inputs and for configuration instruction.

- (1.) If the indoor temperature is below the temperature set point and the humidity is above the humidity set point, the Thermidistat™ closes circuit R to O, opens circuits R to DH and R to G, and closes circuit R to Y/Y2. If circuit R to G is closed (24-v.), the motor will deliver airflow at the full cooling or cooling plus dehumidify mode requested value. If circuit R to G is open (0-v.) for Super Dehumidify mode, the motor delivers reduced airflow to maximize the humidity removal of the system while minimizing over cooling.

e. GAS HEATING MODE

- (1.) Thermostat closes circuit R to W/W1—The unit delivers the selected gas heat airflow. The IGC will control a 45 sec. blower “On” delay and a 45 sec. “Off” delay.

E. Easy Select™—683B

NOTE: Either the Bryant Thermidistat™ or Dual Fuel thermostat is required for operation of the dual-fuel (683B) units. Be sure to follow the installation instructions supplied with the Thermidistat™. Either indoor temperature control must use an outdoor air sensor to properly control heating operation.

EASY SELECT™ CONFIGURATION TAPS FOR 683B

Easy Select™ taps are used by the installer to configure a system. The ICM motor uses the selected taps to modify its operation to a pre-programmed table of airflows.

The unit must be configured to operate properly with system components with which it is installed. To successfully configure a basic system (see information printed on circuit board label located next to select pins), move the 6 select wires to the pins which match the components used (See Fig. 8).

a. GAS HEAT/CFM—SELECT GAS HEAT INPUT SIZE

Factory selected gas heat size should correspond to unit label.

b. AC/HP SIZE—SELECT SYSTEM SIZE INSTALLED

Factory selected air conditioner size should correspond to capacity of unit installed. Installer should verify air conditioner size to ensure that airflow delivered falls within proper range for the size unit installed. This applies to all operational modes.

c. SYSTEM TYPE—SELECT SYSTEM TYPE INSTALLED

Factory selected on 683B for HP-EFF.

SELECT OPTIONS

1. HP-COMFORT provides approximately 315 CFM/ton for higher normal heating air temperature and provides approximately 350 CFM/ton cooling airflow for good humidity re-

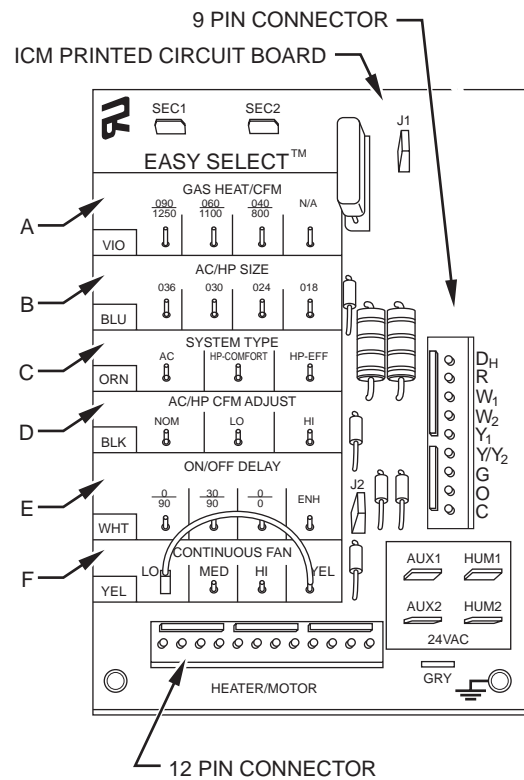

C01039

Fig. 8—Detail of SPP Printed-Circuit Board

moval

2. HP-EFF (factory selected) Provides equal airflow for heating and cooling modes to increase overall heat pump efficiency. Provides approximately 400 CFM/ton.

d. AC/HP CFM ADJUST—SELECT NOMINAL, LOW, OR HIGH AIRFLOW

The AC/HP CFM Adjust select is factory set to the High-HI (NOM for 036, 060) tap. The CFM Adjust selections NOM/LO will regulate airflow supplied for all operational modes, except non-heat pump heating modes. HI provides 15 percent airflow over nominal unit size selected and LO provides 10 percent airflow below nominal unit size selected. Adjust selection options are provided to adjust airflow supplied to meet individual installation needs for such things as noise, comfort, and humidity removal (See Fig. 8, D as indicated).

e. ON/OFF DELAY—SELECT DESIRED TIME DELAY PROFILE

Four motor operation delay profiles are provided to customize and enhance system operation (See Fig. 8, E as indicated). Selection options are:

- (1.) The standard 90 sec off delay (Factory Setting) at 100 percent airflow in cooling or heat pump heating mode. In gas heating mode, IGC will control a 45 sec “On” delay and a 45 sec “Off” delay.
- (2.) A 30 sec cooling delay with no airflow/ 90 sec off delay at 100 percent airflow profile is used when it is desirable to allow system coils time to cool-down/heat-up in conjunction with the airflow in cooling or heat pump heating mode.
- (3.) A no delay option used for servicing unit or when a thermostat is utilized to perform delay functions. In gas heating mode IGC will control 45 sec on delay with no airflow and 45 sec off delay.

- (4.) ENH (enhanced) selection provides a 30 sec. cooling & heat pump *on delay* with no airflow, plus 150 seconds at 70 percent airflow and *no off delay* for added comfort. This will minimize *cold blow* in heat pump operation and could enhance system efficiency.

f. CONTINUOUS FAN—SELECT DESIRED FAN SPEED WHEN THERMOSTAT IS SET ON CONTINUOUS FAN

- (1.) LO speed—Factory setting, 50 percent cooling mode airflow.
- (2.) MED speed—Move connector to MED, 65 percent cooling mode airflow.
- (3.) HI speed—Move connector to HI, 100 percent cooling mode airflow (See Fig. 8, F as indicated).

g. LOW-VOLTAGE CIRCUIT FUSING AND REFERENCE

The low-voltage circuit is fused by a board-mounted 5-amp automotive fuse placed in series with the transformer SEC2 and the R circuit. The C circuit of the transformer is referenced to chassis ground through a printed circuit run at SEC1 connected to metal standoff marked with ground symbol.

h. BASIC UNIT CONFIGURATION

The following basic configuration of the indoor motor will provide ARI rated performance of the 683B. *This BASIC CONFIGURATION should be used when the rated ARI performance is required.*

- (1.) HEAT—Factory selected to match heat input size.
- (2.) AC/HP Size—Factory selected to match system size, please verify.
- (3.) SYSTEM TYPE—Factory selected on 683B system for HP-EFF.
- (4.) AC/HP CFM ADJUST—Select HIGH for 042 & 048, NOM for 036 & 060, and LO for 024 & 030.
- (5.) ON/OFF DELAY—Factory selected 0/90 profile.
- (6.) CONTINUOUS FAN—Select desired fan speed when thermostat is set to continuous fan.

i. COMFORT OPTIONS—SUPER DEHUMIDIFY (See Quick Reference Guide)

The Super Dehumidify option is possible when this unit is installed with a field supplied Thermidistat™ control (Super-Dehumidify does not require an outdoor temperature sensor). The following configuration is recommended for maximum cooling/dehumidifying comfort. This configuration will improve the comfort provided by the air conditioning system if more humidity removal is desired. While providing this improved comfort, the system will operate efficiently, but not at the published ARI SEER efficiency.

The following system configuration is recommended for maximum cooling/dehumidifying comfort (See Fig. 8).

- (1.) HEAT—Factory selected to match gas heat size of unit installed.
- (2.) AC/HP Size—Factory selected to match system size, please verify.
- (3.) SYSTEM TYPE—Factory selected on 683B system for HP-EFF.
- (4.) AC/HP CFM ADJUST—Select NOM (Lo for 060).
- (5.) ON/OFF DELAY—Select ENH profile.
- (6.) CONTINUOUS FAN—Select desired fan speed when thermostat is set to continuous fan.
- (7.) LOW VOLTAGE CONNECTIONS—Make connections as shown in ELECTRICAL CONNECTIONS section.

- (8.) CONFIGURE THERMIDISTAT™—Follow Thermidistat™ installation instructions for Super Dehumidify operation.

ACCESSORY INSTALLATION

a. AUXILIARY TERMINALS

The AUX and HUM terminals on the Easy Select™ Board are tied directly to the G terminal, and provide a 24-v. signal whenever the G terminal is energized (See Fig. 9). During Super dehumidify mode, the G signal is not present and the auxiliary terminals are not energized. If the installation includes the use of this operating mode, do not use these terminals to control accessories. See Electronic Air Cleaner and Humidifier sections for further information.

b. ELECTRONIC AIR CLEANER CONNECTIONS

The AUX1 and AUX2 terminals are not always energized during blower operations, as described above. When using an electronic air cleaner with the unit, use Airflow Sensor P/N. KEAAC0101AAA. The airflow sensor turns on electronic air cleaner when the blower is operating.

c. HUMIDIFIER / THERMIDISTAT™ CONNECTIONS

Easy Select™ Board terminals HUM1 and HUM2 are provided for direct connection to the low-voltage control of a humidifier through a standard Thermidistat™ (See Fig. 9). These terminals are energized with 24-v. when G thermostat signal is present (See Fig. 10). Alternately, the 24-v. signal may be sourced from the W and C on the 9 pin connector. When using a Thermidistat™ Control the 24-v. signal may be sourced directly from the Thermidistat™ HUM terminal (See Fig. 8, 9 & 10).

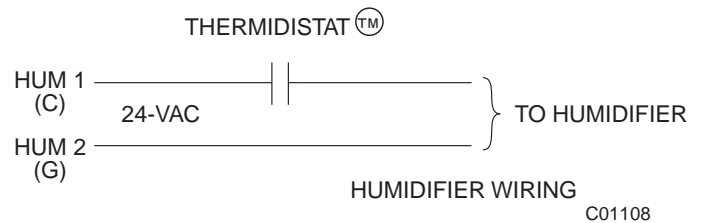

Fig. 9—Humidifier Wiring-683B

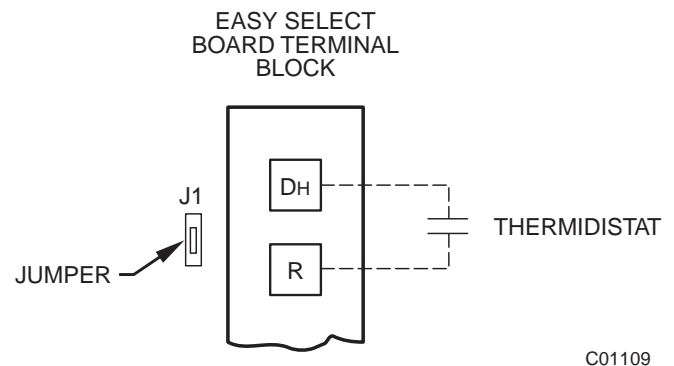

Fig. 10—Thermidistat™ Wiring for De-Humidify Mode-683B

d. DEHUMIDIFY CAPABILITY WITH STANDARD THERMIDISTAT™ CONNECTION

Latent capacities for this unit are better than average systems. If increased latent capacity is an application requirement, the ICM board provides connection terminals for use of a Thermidistat™. The unit will detect the Thermidistat™ contacts opening on increasing humidity and reduce its airflow to approximately 80 percent of nominal cooling mode airflow. This reduction will increase the system latent capacity until the humidity falls

to a level which causes the Thermidstat™ to close its contacts. When the contacts close, the airflow will return to 100 percent of selected cooling airflow. To activate this mode wire in Thermidstat™ see jumper in Fig. 10.

e. DEHUMIDIFY AND SUPER DEHUMIDIFY CAPABILITIES

This model unit is capable of responding to a signal from Thermidstat™ to operate in comfort control modes such as Super Dehumidify Mode. Consult literature provided with Thermidstat™ to determine if these operating modes are available, and to see control set up instructions. No special setup or wiring of unit is required.

F. 683B Sequence of Operation

a. CONTINUOUS FAN

(1.) Thermostat closes circuit R to G—The Blower runs at continuous fan airflow

b. COOLING MODE

(1.) If indoor temperature is above temperature set point and humidity is below humidity set point, thermostat closes circuits R to G, R to Y/Y2 and R to O—The unit delivers single speed cooling airflow.

c. COOLING MODE-DEHUMIDIFICATION

(1.) If indoor temperature is above temperature set point and humidity is above humidity set point, Thermidstat™ closes circuits R to G, R to Y/Y2, R to O and Thermidstat™ opens R to DH—The unit delivers airflow which is approximately 80 percent of the nominal cooling airflow to increase the latent capacity of the system.

d. COOLING MODE-SUPER DEHUMIDIFY OPERATION (SEE QUICK REFERENCE GUIDE)

NOTE: Thermidstat™ is capable of providing Super Dehumidify operation mode and must be configured as outlined in its installation instructions. Consult indoor control literature to determine if control is capable of providing Super Dehumidify inputs and for configuration instruction.

(1.) If the indoor temperature is below the temperature set point and the humidity is above the humidity set point, the Thermidstat™ closes circuit R to O, opens circuits R to DH and R to G, and closes circuit R to Y/Y2. If circuit R to G is closed (24-v.), the motor will deliver airflow at the full cooling or cooling plus dehumidify mode requested value. If circuit R to G is open (0-v.) for super dehumidify mode, the motor delivers reduced airflow to maximize the humidity removal of the system while minimizing over cooling.

e. GAS HEATING MODE

(Occurs if outdoor temperature is below outdoor temperature change over setpoint.)

(1.) Thermostat closes circuit R to W/W1—The unit delivers the selected gas heat airflow. The IGC will control 45 sec. on delay with no airflow and 45 sec. off delay.

f. HEAT PUMP HEATING MODE

(Occurs if outdoor temperature is above outdoor temperature change over setpoint.)

(1.) Thermidstat™ closes circuit R to G and R to Y/Y2—The unit delivers selected heat pump heating airflow.

g. HEATING MODE—SUPER COMFORT HEAT OPERATION

NOTE: The Thermidstat™ is capable of providing Super Comfort Heat operation mode and must be configured as outlined in its installation instructions. The system must be installed with appropriate outdoor temperature sensor. Consult Thermidstat™ literature for configuration instructions. Consult sensor instructions for sensor installation details.

If the outdoor temperature is in the range of 12° to 40° F, the Thermidstat™ closes circuit R to Y/Y2 and opens circuit R to G. If circuit R to G is closed (24-v.), the motor will deliver airflow at the full heating requested value. If circuit R to G is open (0-v.) for maximum heating comfort, the motor delivers reduced airflow to maximize the temperature and minimize the draft effect of the heated air leaving the unit.

G. Easy Select™—702B & 602B

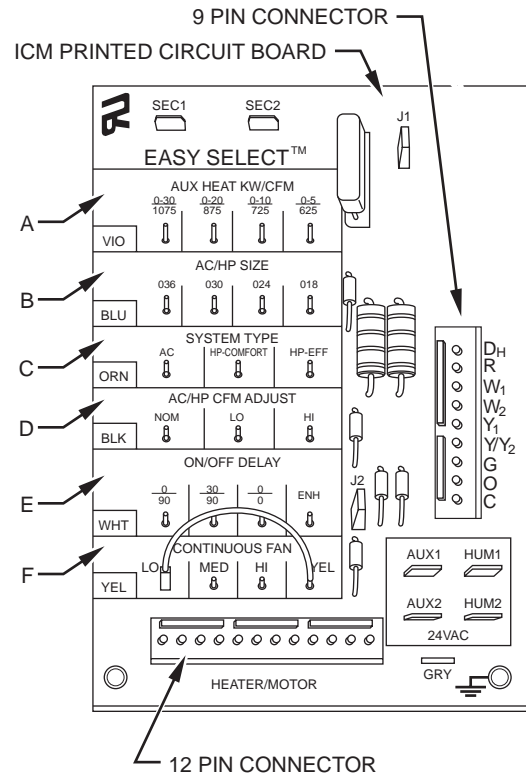

C01033

Fig. 11—Detail of SPP Printed-Circuit Board

EASY SELECT™ CONFIGURATION TAPS FOR 702B & 602B

Easy Select™ taps are used by the installer to configure a system. The ICM motor uses the selected taps to modify its operation to a pre-programmed table of airflows.

The unit must be configured to operate properly with system components with which it is installed. To successfully configure a basic system (see information printed on circuit board label located next to select pins), move the 6 select wires to the pins which match the components used.

a. AUX HEAT kW/CFM—SELECT HEATER RANGE FOR SIZE OF ELECTRIC HEATER INSTALLED

Installer must select the auxiliary heat airflow approved for application with kW size heater installed. If no heater is installed, this step can be skipped. Each select pin is marked with a range of heaters for which airflow (also marked), is approved. For increased comfort, select the narrowest kW range matching the heater size, for example, 0–10 for 10-kW heater. This airflow must be greater than the minimum for CFM for electric heater application with the size system installed for safe and continuous operation. (See Tables 16, 17 & 18 for airflow delivery and minimum CFM.) Note that airflow marked is the

airflow which will be supplied in emergency heat mode and heating mode on air conditioners when electric heat is the primary heating source. In heat pump heating mode when electric heaters are energized, the ICM will run the higher of heat pump heating airflow and electric heater airflow to ensure safe heater operation. The factory selection is the largest heater range approved (See Fig. 11, A as indicated).

b. AC/HP SIZE—SELECT SYSTEM SIZE INSTALLED

The factory setting for air conditioner or heat pump size is the size which matches the model of packaged unit installed. Installer should verify air conditioner or heat pump size to ensure that airflow delivered falls within proper range for the size unit installed. This applies to all operational modes with the exception of electric heat modes (See Fig. 11, B as indicated).

c. SYSTEM TYPE—SELECT SYSTEM TYPE INSTALLED

The type of system will be factory selected (see below for details):

- (1.) AC-Air conditioner (Factory Selected for 702B)
- (2.) HP-COMFORT—Heat Pump Comfort provides approximately 315 CFM per ton for higher normal heating air delivery temperature and provides approximately 350 CFM per ton cooling airflow for good humidity removal.
- (3.) HP-EFF (Factory Selected for 602B)—Heat Pump Efficiency provides same airflow for heating and cooling modes to increase overall HP efficiency; approximately 350 CFM per ton.

d. AC/HP CFM ADJUST—SELECT NOMINAL, LOW, OR HIGH AIRFLOW

The AC/HP CFM Adjust select is factory set to the High-Hi (NOM for 060) tap. The CFM Adjust selections NOM/LO will regulate airflow supplied for all operational modes, except non-heat pump heating modes. HI provides 15 percent airflow over nominal unit size selected and LO provides 10 percent airflow below nominal unit size selected. CFM Adjust selection options are provided to adjust airflow supplied to meet individual installation needs for such things as noise, comfort, and humidity removal (See Fig. 11, D as indicated).

e. ON/OFF DELAY—SELECT DESIRED TIME DELAY PROFILE

Four motor operation delay profiles are provided to customize and enhance system operation (See Fig. 11, E as indicated). Selection options are:

- (1.) The standard 90 sec off delay (Factory Setting) at 100 percent airflow in cooling or heat pump heating mode.
- (2.) A 30 sec cooling delay with no airflow/90 sec off delay at 100 percent airflow profile is used when it is desirable to allow system coils time to heat-up/cool-down in conjunction with the airflow in cooling or heat pump heating mode.
- (3.) A no delay option used for servicing unit or when a thermostat is utilized to perform delay functions.
- (4.) ENH, enhanced selection, provides a 30 sec cooling on delay with no airflow/ plus 150 sec at 70 percent airflow/ no off delay for added comfort.
This will minimize cold blow in heat pump operation (602B only) and could enhance system efficiency.

f. CONTINUOUS FAN—SELECT DESIRED FAN SPEED WHEN THERMOSTAT IS SET ON CONTINUOUS FAN

- (1.) LO speed—Factory setting, 50 percent cooling mode airflow.

- (2.) MED speed—Move connector to MED, 65 percent cooling mode airflow.
- (3.) HI speed—Move connector to HI, 100 percent cooling mode airflow (See Fig. 11, F as indicated).

g. LOW-VOLTAGE CIRCUIT FUSING AND REFERENCE

The low-voltage circuit is fused by a board-mounted 5-amp automotive fuse placed in series with the transformer SEC2 and the R circuit. The C circuit of the transformer is referenced to chassis ground through a printed circuit run at SEC1 connected to metal standoff marked with ground symbol.

h. BASIC UNIT CONFIGURATION

The following basic configuration of the indoor motor will provide ARI rated performance of the System. *This BASIC CONFIGURATION should be used when the rated ARI performance is required, or if system enhancements such as super dehumidify are not needed.*

- (1.) AUX HEAT kW/CFM-Select the heater range for the size of electric heater installed (skip this step if no heater is installed).
- (2.) AC/HP SIZE-Factory selected to match system size installed, please verify.
- (3.) SYSTEM TYPE-Factory selected AC (702B) or HP-EFF (602B).
- (4.) AC/HP CFM ADJUST-Select HIGH for 042 & 048, NOM for 036 & 060, and LO for 024 & 030.
- (5.) ON/OFF DELAY-Select 0/90 profile.
- (6.) CONTINUOUS FAN-Select desired fan speed when thermostat is set to continuous fan.

i. COMFORT OPTIONS—SUPER DEHUMIDIFY (See Quick Reference Guide)

The Super Dehumidify option is possible when this unit is installed with a field supplied Thermidistat™ control (Super Dehumidify does not require an outdoor temperature sensor). The following configuration is recommended for maximum cooling/dehumidifying comfort: This configuration will improve the comfort provided by the air conditioning system if more humidity removal is desired. While providing this improved comfort, the system will operate efficiently, but not at the published HSPF or ARI SEER efficiency.

The following system configuration is recommended for maximum heating and cooling/dehumidifying comfort (See Fig. 11).

- (1.) AUX HEAT kW/CFM-Select the narrowest heater range to match size of electric heater installed (skip this step if no heater is installed).
- (2.) AC/HP Size-Factory selected to match system size installed, please verify.
- (3.) SYSTEM TYPE-Select system type HP-COMFORT (for heat pump system) or AC (for air conditioner system).
- (4.) AC/HP CFM ADJUST-Select NOM (Lo for 060).
- (5.) ON/OFF DELAY-Select ENH profile.
- (6.) CONTINUOUS FAN-Select desired fan speed when thermostat is set to continuous fan.
- (7.) DEHUMIDIFY MODE-Remove J1 jumper to activate.
- (8.) LOW VOLTAGE CONNECTIONS-Make connections as shown in ELECTRICAL CONNECTIONS section.
- (9.) CONFIGURE THERMIDISTAT™ (or capable zoning system)-Following its installation instructions for Super Dehumidify and Super Comfort Heat operation.

This configuration provides the following comfort enhancements:

- (a.) A 30 sec blower on delay with 150 sec at 70 percent airflow to allow the indoor coil to warm up or cool down before the blower is asked to deliver 100 percent airflow reducing the cold blow sensation at start up in heating and allowing the indoor coil to more quickly reach wet coil operating conditions in cooling.
- (b.) A no blower off delay eliminates cold blow which may be associated with running the blower after shut down of the compressor and avoids re-evaporation of condensed moisture after cooling/dehumidifying operation.
- (c.) Lower airflow while the compressor is running to reduce draft effects and increase heating air temperature and improved humidity control during cooling operation.

ACCESSORY INSTALLATION

a. ACCESSORY ELECTRIC HEATERS

Electric heaters may be installed with the 702B & 602B units per instructions supplied with electric heater package. See unit rating plate for factory-approved electric heater kits.

b. AUXILIARY TERMINALS

The AUX and HUM terminals on the Easy Select™ Board are tied directly to the G terminal, and provide a 24-v. signal whenever the G terminal is energized (See Fig. 12). During Super dehumidify mode, the G signal is not present and the auxiliary terminals are not energized. If the installation includes the use of the operating mode, do not use these terminals to control accessories. See Electronic Air Cleaner and Humidifier sections for further information.

c. ELECTRONIC AIR CLEANER CONNECTIONS

The AUX1 and AUX2 terminals are not always energized during blower operations, as described above. When using an electronic air cleaner with the unit, use Airflow Sensor P/N KEAAC0101AAA. The airflow sensor turns on electronic air cleaner when the blower is operating.

d. HUMIDIFIER/HUMIDISTAT CONNECTIONS

Easy Select™ Board terminals HUM1 and HUM2 are provided for direct connection to the low-voltage control of a humidifier through a standard humidistat (See Fig. 12). These terminals are energized with 24-v. when G thermostat signal is present. (See Fig. 11, 12 & 13). Alternately, the 24-v. signal may be sourced from the W and C circuit board connections. When using a Thermidistat™ Control, Zone Perfect Plus or Comfort Zone II, the 24-v. signal may be sourced directly from the Thermidistat™ HUM terminal.

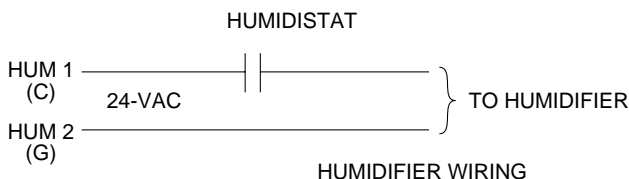

A95317

Fig. 12—Humidifier Wiring for 702B & 602B

e. DEHUMIDIFY CAPABILITY WITH STANDARD HUMIDISTAT CONNECTION

Latent capacities for these units are better than average systems. If increased latent capacity is an application requirement, the circuit board provides connection terminals for use of a

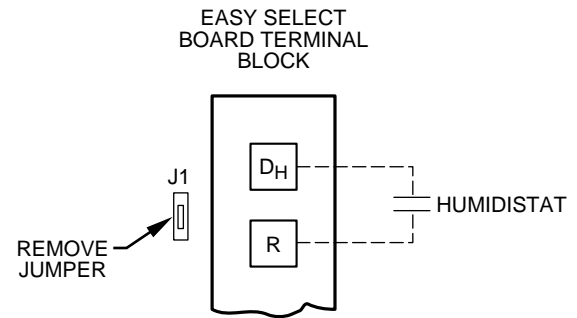

A95316

Fig. 13—Humidistat Wiring for De-Humidify Mode-for 702B & 602B

standard humidistat. The unit will detect the humidistat contacts opening on increasing humidity and reduce its airflow to approximately 80 percent of nominal cooling mode airflow. This reduction will increase the system latent capacity until the humidity falls to a level which causes the humidistat to close its contacts. When the contacts close, the airflow will return to 100 percent of selected cooling airflow. To activate this mode, remove jumper J1 and wire in a standard humidistat (See Fig. 13).

f. DEHUMIDIFY AND SUPER DEHUMIDIFY CAPABILITIES

these models are capable of responding to a signal from indoor system control (thermostat, Thermidistat™, zoning control) to operate in comfort control modes such as Super Dehumidify Mode. Consult literature provided with indoor system control to determine if these operating modes are available, and to see control set up instructions. No special setup or wiring of unit is required.

H. 702B & 602B Sequence Of Operation

a. CONTINUOUS FAN

- (1.) Thermostat closes circuit R to G—The Blower runs at continuous fan airflow.

b. COOLING MODE-LOW HUMIDITY

- (1.) If indoor temperature is above temperature set point and humidity is below humidity set point, thermostat closes circuits R to G, R to Y/Y2 and R to O—The unit delivers cooling airflow.

c. COOLING MODE-DEHUMIDIFICATION

- (1.) If indoor temperature is above temperature set point and humidity is above humidity set point, thermostat or Thermidistat™ closes circuits R to G, R to O, and R to Y/Y2 and humidistat or Thermidistat™ opens R to DH—The unit delivers airflow which is approximately 80 percent of the nominal cooling airflow to increase the latent capacity of the system.

d. COOLING MODE-SUPER DEHUMIDIFY OPERATION (see quick reference guide)

NOTE: The indoor control used, such as a Thermidistat™, must be capable of providing Super Dehumidify operation mode and control must be configured as outlined in its installation instructions. Consult indoor control literature to determine if control is capable of providing Super Dehumidify inputs and for configuration instruction.

- (1.) If the indoor temperature is below the temperature set point and the humidity is above the humidity set point, the Thermidistat™ closes circuit R to O, opens circuits R to DH and R to G, and cycles circuit R to Y/Y2. If circuit R to G is closed (24-v.), the motor will deliver airflow at the full cooling or cooling plus dehumidify mode requested

value. If circuit R to G is open (0-v.) for super dehumidify mode, the motor delivers reduced airflow to maximize the humidity removal of the system while minimizing over cooling.

e. ELECTRIC HEATING MODE

- (1.) Thermostat closes circuit R to W/W1, or W2—The unit delivers the selected electric heat airflow. There are no on or off delays.

f. HEAT PUMP HEATING MODE (602B only)

- (1.) Thermostat closes circuits R to G and R to Y/Y2—The unit delivers selected heat pump heating airflow.

g. HEAT PUMP HEATING WITH AUXILIARY ELECTRIC HEAT (602B only)

- (1.) Thermostat closes circuits R to G, R to Y/Y2 and R to W/W1 or W2 (and R to O in the case of defrost).

In the event that electric heating is called for by the thermostat while the heat pump is also operating in either heating or defrost modes, the motor will modify its airflow output, if necessary, to provide an airflow which is defined as safe for the operation of the electric heater during heat pump operation. That airflow is the greater of the heat pump heating airflow and the electric heater only airflow.

h. HEATING MODE—SUPER COMFORT HEAT OPERATION

NOTE: The indoor control used, such as a Thermidistat™, must be capable of providing Super Comfort Heat operation mode and control must be configured as outlined in its installation instructions. The system must be installed with appropriate outdoor temperature sensor. Consult indoor control literature to determine if control is capable and for configuration instructions. Consult indoor control instructions and sensor instructions for sensor installation details.

If the outdoor temperature is in the range of 12° to 40° F, the Thermidistat™ closes circuit R to Y/Y2 and opens circuit R to G. If circuit R to G is closed (24-v.), the motor will deliver airflow at the full heating requested value. If circuit R to G is open (0-v.) for maximum heating comfort, the motor delivers reduced airflow to maximize the temperature and minimize the draft effect of the heated air leaving the unit.

ICM FIOP START-UP

ICM General Start Up

CHECKING AND ADJUSTING REFRIGERANT CHARGE

The refrigerant system is fully charged with Puron® (R-410A) refrigerant, and is tested and factory sealed.

NOTE: Adjustment of the refrigerant charge is not required UNLESS the unit is suspected of not having the proper R-410A charge.

The charging label and the tables shown refer to system temperatures and pressures. The temperatures and pressures are calculated at rated airflow. When charging unit, set to rated airflow. A refrigerant charging chart label is attached to the outside of the compressor access door. The chart includes the required suction line temperature at given suction line pressures and outdoor ambients. An accurate superheat, thermocouple- or thermistor-type thermometer, and gage manifold are required when using the superheat charging method for evaluating the unit charge. **Do not use mercury or small dial-type thermometers because they are not adequate for this type of measurement**

IMPORTANT: When evaluating the refrigerant charge, an indicated adjustment to the specified factory charge must always be very minimal. If a substantial adjustment is indicated, an abnormal condition exists somewhere in the cooling system, such as insufficient airflow across either one or both coils.

I. 583B START-UP (ICM FIOP)

CHECKING COOLING CONTROL OPERATION—Start and check the unit for proper cooling control operation as follows:

- (1.) Place room thermostat SYSTEM switch in OFF position. Observe that blower motor starts when FAN switch is placed in ON position and shuts down when FAN switch is placed in AUTO position. Note fan delay time setting selected on the Easy Select™ board. (See Easy Select Section.)
- (2.) Place SYSTEM switch in COOL position and FAN switch in AUTO position. Set cooling control below room temperature. Observe that compressor, condenser fan, and evaporator blower motors start. Observe that cooling cycle shuts down when control setting is satisfied. The evaporator fan will continue to run for the time setting selected on Easy Select™ board. (See Easy Select Section.)
- (3.) When using an auto-changeover room thermostat, place both SYSTEM and FAN switches in AUTO position. Observe that unit operates in heating mode when temperature control is set to “call for heating” (above room temperature) and operates in cooling mode when temperature control is set to “call for cooling” (below room temperature).

AIRFLOW AND TEMPERATURE RISE—The heating section for each size unit is designed and approved for heating operation within the temperature rise range stamped on the unit rating plate. Table 15 shows the approved temperature rise range for each heating input, and the air delivery (CFM) at various temperature rise ranges.

The heating operation airflow must produce a temperature rise that falls within the approved range.

Refer to Indoor Airflow and Airflow Tables on the following pages to adjust heating airflow when required.

CHECK HEATING CONTROL—Start and check the unit for proper heating control operation as follows. (see furnace lighting instructions located inside burner or blower access panel.):

- (1.) Place room thermostat SYSTEM switch in the HEAT position and the FAN switch in the AUTO position.
- (2.) Set the heating temperature control of the thermostat above room temperature.
- (3.) The induced-draft motor will start.
- (4.) After a call for heating, the main burner should light within 5 sec. If the burners still do not light, this sequence is repeated. If the burners do not light within 15 minutes from the initial call for heat, there is a lockout. To reset the lockout control, break the 24-v. power to W.
- (5.) The indoor fan will turn on 45 sec after the flame has been established. The indoor fan will turn off according to time delay selected on the Easy Select™ board (See Easy Select Section) after the thermostat has been satisfied.

II. 683B START-UP (ICM FIOP)

Also refer to the Thermidistat™ instructions for start up and check out of the system.

- (1.) FAN OPERATION—
The fan button on Thermidistat™ switches fan icon between *AUTO* and *ON*. While *ON* is displayed, output will be on, turning fan on. Allow up to 10 sec. after button is pressed for fan to turn on and off. The fan will continue to run for the time setting selected on the Easy Select™ board after *AUTO* icon is displayed.
- (2.) COOLING MODE—
Press *MODE* button on the Thermidistat™ until *COOL* icon is displayed. Cooling begins within 10 sec. and

remains on for 4 minutes. Observe that compressor, outdoor fan and indoor blower motors start after the call for *Cooling*. At the end of 4 minutes, the cooling cycle stops and the *MODE* reverts back to *OFF*. The Indoor Blower continues to run for the time selected on the Easy Select™ board after *OFF* icon is displayed.

(3.) HEAT PUMP HEATING—

Press *MODE* button on the Thermidistat™ until *HEAT* icon is displayed. Heat pump heating begins within 10 sec. and remains on for 4 minutes. Observe that the compressor, outdoor fan and indoor blower come on. At the end of the 4 minutes, heating cycle stops and the *MODE* reverts back to *OFF*. The indoor blower continues to run for the time selected on the Easy Select™ Board after the *OFF* icon is displayed. Heating maybe turned off anytime during the 4 minute cycle by pressing *MODE* button until *OFF* is displayed.

(4.) GAS HEAT MODE—

Press *MODE* button until *E-HEAT*(Emergency Heat or Back-Up Heat) icon is displayed. Gas heating begins within 10 sec. and remains on for 4 minutes. The induced draft motor should start immediately. The burners should light within 5 sec. of *E-HEAT* call. The indoor blower will turn on 45 sec. after the flame has been established. Gas heating stops at the end of 4 minutes and *MODE* reverts back to *OFF*. The indoor blower continues to run for the time selected on the Easy Select™ Board after the *OFF* icon is displayed.

NOTE: If the burners do not light, this lighting sequence is repeated for 15 minutes from the initial call for *E-HEAT*. If after 15 minutes the burners do not light, there will be a lockout. To reset the burner lockout control, break the 24-v. power to “W”.

(5.) AUTOMATIC CHANGE-OVER—

To test *AUTO CHANGE-OVER* function between *COOL* and *HEAT*:

Enable the *AUTO CHANGE-OVER* mode during Thermidistat™ set-up. Refer to the Thermidistat™ literature for details. Observe that the unit operates in cooling when in *COOL MODE* (when setting is below room temperature) and *HEAT MODE* (when setting is above room temperature).

AIRFLOW AND TEMPERATURE RISE—The heating section for each size unit is designed and approved for heating operation within the temperature rise range stamped on the unit rating plate. Table 15 shows the approved temperature rise range for each heating input, and the air delivery (CFM) at various temperature rise ranges.

The heating operation airflow must produce a temperature rise that falls within the approved range.

Refer to Indoor Airflow and Airflow Tables on the following pages to adjust heating airflow when required.

III. 702B: START-UP (ICM FIOP)

CHECKING COOLING CONTROL OPERATION—Start and check the unit for proper cooling control operation as follows:

- (1.) Place room thermostat SYSTEM switch in OFF position. Observe that blower motor starts when FAN switch is placed in ON position and shuts down when FAN switch is placed in AUTO position.
- (2.) Place SYSTEM switch in COOL position and FAN switch in AUTO position. Set cooling control below room temperature. Observe that compressor, condenser fan, and evaporator blower motors start. Observe that cooling cycle shuts down when control setting is satisfied. The evaporator fan will continue to run for the selected off delay.

- (3.) When using an auto-changeover room thermostat, place both SYSTEM and FAN switches in AUTO positions. Observe that unit operates in heating mode when temperature control is set to “call for heating” (above room temperature) and operates in cooling mode when temperature control is set to “call for cooling” (below room temperature).

NOTE: Once the compressor has started and then has stopped, it will not start again until 5 minutes have elapsed. (The cooling cycle remains “on” until the room temperature drops to point that is slightly below the cooling control setting of the room thermostat. At this point, the thermostat “breaks” the circuit between thermostat terminal R to terminals Y and G.) These open circuits de-energize contactor coil C and ICM board. The condenser and compressor motors stop. After the time delay setting selected on the Easy Select™ board (See Easy Select Section) , the blower motor stops. The unit is in a “standby” condition, waiting for the next “call for cooling” from the room thermostat.

IV. 602B: START-UP (ICM FIOP)

CHECKING COOLING AND HEATING CONTROL OPERATION— Start and check the unit for proper control operation as follows:

- (1.) Place room thermostat SYSTEM switch or MODE control in OFF position. Observe that blower motor starts when FAN mode is placed in FAN ON position and shuts down according to time delay selected on the Easy Select™ board (See Easy Select Section) when FAN MODE switch is placed in AUTO position.
- (2.) *Thermostat:*
When the room temperature rises to a point that is slightly above the cooling control setting of the thermostat, the thermostat completes the circuit between thermostat terminal R to terminals Y, O and G. These completed circuits through the thermostat connect contactor coil (C) (through unit wire Y) and ICM board (through unit wire G) across the 24-v. secondary of transformer (TRAN).
Thermidistat™ or Thermostat and Humidistat:
When the room temperature rises to a point that is slightly above the cooling control setting of the thermostat, the thermostat completes the circuit between thermostat terminal R to terminals Y, O, DH, and G. These completed circuits through the thermostat connect contactor coil (C) (through unit wire Y) and ICM board (though unit wire G) across the 24-v. secondary of transformer (TRANS).
- (3.) Place system switch or MODE control in HEAT position. Set control above room temperature. Observe that compressor, outdoor fan, and indoor blower motors start. Observe that heating cycle shuts down according to time delay selected on the Easy Select™ board (See Easy Select Section) when control setting is satisfied.
- (4.) When using an automatic changeover room thermostat, place both SYSTEM or MODE control and FAN mode switches in AUTO positions. Observe that unit operates in Cooling mode when temperature control is set to “call for Cooling” (below room temperature), and unit operates in Heating mode when temperature control is set to “call for Heating” (above room temperature).

NOTE: Once the compressor has started and then has stopped, it should not be started again until 5 minutes have elapsed. The cooling cycle remains “on” until the room temperature drops to point that is slightly below the cooling control setting of the room thermostat. At this point, the thermostat “breaks” the circuit between thermostat terminal R to terminals Y and G. These open circuits de-energize contactor coil C and ICM board. The condenser and compressor motors stop. After the time delay setting selected on the Easy Select™ board (See Easy Select Section) , the

TABLE 1—ICM FIOP PHYSICAL DATA—UNIT 583B

THIS DATA APPLIES TO 583B UNITS WITH THE ICM INDOOR MOTOR FIOP								
UNIT SIZE 583B	024040	024060	030040	030060	036060	036090	042060	042090
NOMINAL CAPACITY (ton)	2	2	2-1/2	2-1/2	3	3	3-1/2	3-1/2
OPERATING WEIGHT (lb.)	290	290	313	313	321	321	382	382
COMPRESSORS Quantity	Scroll 1							
REFRIGERANT (R-410A) Quantity (lb.)	5.0	5.0	5.5	5.5	6.9	6.9	9.0	9.0
REFRIGERANT METERING DEVICE Orifice ID (in.) Check-Flo-Rater™ Piston	.057	.057	.057	.057	.065	.065	.070	.070
CONDENSER COIL Rows...Fins/in. Face Area (sq ft)	1...17 10.9	1...17 10.9	1...17 12.7	1...17 12.7	2...17 9.1	2...17 9.1	2...17 12.3	2...17 12.3
CONDENSER FAN Nominal Cfm Diameter (in.) Motor HP (Rpm)	2350 22 1/8 (825)	2350 22 1/8 (825)	2350 22 1/8 (825)	2350 22 1/8 (825)	2350 22 1/8 (825)	2350 22 1/8 (825)	2350 22 1/8 (825)	2350 22 1/8 (825)
EVAPORATOR COIL Rows...Fins/in. Face Area (sq ft)	3...15 3.7	3...15 3.7	3...15 3.7	3...15 3.7	3...15 3.7	3...15 3.7	3...15 4.7	3...15 4.7
EVAPORATOR BLOWER Nominal Airflow (Cfm) Size (in.) Motor (HP)	800 10 X 10 1/2	800 10 X 10 1/2	1000 10 X 10 1/2	1000 10 X 10 1/2	1200 11 X 10 3/4	1200 11 X 10 3/4	1400 11 X 10 3/4	1400 11 X 10 3/4
FURNACE SECTION* Burner Orifice No. (Qty...Drill Size) Natural Gas Burner Orifice No. (Qty...Drill Size) Propane Gas	2...44 2...50	2...38 2...46	2...44 2...50	2...38 2...46	2...38 2...46	3...38 3...46	2...38 2...46	3...38 3...46
HIGH-PRESSURE SWITCH (psig) Cutout Reset (Auto)	610 ± 15 420 ± 25							
LOSS-OF-CHARGE/LOW-PRESSURE SWITCH (Liquid Line) (psig) Cutout Reset (Auto)	20 ± 5 45 ± 10							
RETURN-AIR FILTERS (in.) Throwaway	20 X 20 X 1	20 X 20 X 1	20 X 20 X 1	20 X 20 X 1	20 X 24 X 1	20 X 24 X 1	24 X 30 X 1	24 X 30 X 1

* Based on altitude of 0 to 2000 ft.

blower motor stops. The unit is in a “standby” condition, waiting for the next “call for cooling” from the room thermostat. The 5 minute compressor delay also applies to heat pump heating mode.

ELECTRICAL DATA & SCHEMATICS—ICM FIOP

I. PHYSICAL DATA & ELECTRICAL SCHEMATICS

Use the Physical Data and Electrical Tables on the following pages for information that applies to Bryant Puron® units with the ICM indoor motor FIOP.

AIRFLOW & TEMPERATURE RISE TABLES—ICM FIOP

II. TABLES FOR SYSTEM SET-UP

Use the Airflow and Temperature Rise Tables on the following pages for information that applies to Bryant Puron® units with the ICM indoor motor FIOP.

CARE AND MAINTENANCE

Indoor Blower and Motor

NOTE: All motors are pre-lubricated. Do not attempt to lubricate these motors. For longer life, operating economy, and continuing efficiency, clean accumulated dirt and grease from the blower wheel and motor annually.

⚠	<p>WARNING: Disconnect and tag electrical power to the unit before cleaning and lubricating any blower motor and wheel. On units with gas heat, turn off the gas supply before disconnecting the electrical power. Failure to adhere to this warning could cause serious injury or death.</p>
---	--

To clean the blower motor and wheel:

1. 1. Remove and disassemble blower assembly as follows:
 - a. Remove unit access panel.
 - b. Carefully pivot blower access panel outward towards the electrical box. Route wiring above blower access panel.
 - c. Disconnect the 5 and 16 pin plugs at the blower motor.
 - d. On all units, remove blower assembly from unit. Remove screws securing blower to vertical partition and slide assembly out. Be careful not to tear insulation in blower compartment.
 - e. Ensure proper reassembly by marking blower wheel and motor in relation to blower housing before disassembly.

TABLE 2—ICM FIOP PHYSICAL DATA—UNIT 583B (CONTINUED)

THIS DATA APPLIES TO 583B UNITS WITH THE ICM INDOOR MOTOR FIOP						
UNIT SIZE 583B	048090	048115	048130	060090	060115	060130
NOMINAL CAPACITY (ton)	4	4	4	5	5	5
OPERATING WEIGHT (lb.)	421	421	421	468	468	468
COMPRESSORS Quantity	Scroll 1					
REFRIGERANT (R-410A) Quantity (lb.)	9.5	9.5	9.5	10.0	10.0	10.0
REFRIGERANT METERING DEVICE Orifice ID (in.) Check-Flo-Rater™ Piston	.073	.073	.073	.086	.086	.086
CONDENSER COIL Rows...Fins/in. Face Area (sq ft)	2...17 12.3	2...17 12.3	2...17 12.3	2...17 16.4	2...17 16.4	2...17 16.4
CONDENSER FAN Nominal Cfm Diameter (in.) Motor Hp (Rpm)	3300 22 1/4 (1100)	3300 22 1/4 (1100)	3300 22 1/4 (1100)	3300 22 1/4 (1100)	3300 22 1/4 (1100)	3300 22 1/4 (1100)
EVAPORATOR COIL Rows...Fins/in. Face Area (sq ft)	4...15 4.7	4...15 4.7	4...15 4.7	4...15 4.7	4...15 4.7	4...15 4.7
EVAPORATOR BLOWER Nominal Airflow (Cfm) Size (in.) Motor (HP)	1600 11 X 10 3/4	1600 11 X 10 3/4	1600 11 X 10 3/4	2000 11 X 10 1.0	2000 11 X 10 1.0	2000 11 X 10 1.0
FURNACE SECTION* Burner Orifice No. (Qty...Drill Size) Natural Gas Burner Orifice No. (Qty...Drill Size) Propane Gas	3...38 3...46	3...33 3...42	3...31 3...41	3...38 3...46	3...33 3...42	3...31 3...41
HIGH-PRESSURE SWITCH (psig) Cutout Reset (Auto)	610 ± 15 420 ± 25					
LOSS-OF-CHARGE/LOW-PRESSURE SWITCH (Liquid Line) (psig) Cutout Reset (Auto)	20 ± 5 45 ± 10					
RETURN-AIR FILTERS (in.) Throwaway	24 X 30 X 1	24 X 30 X 1	24 X 30 X 1	24 X 30 X 1	24 X 30 X 1	24 X 30 X 1

* Based on altitude of 0 to 2000 ft.

TABLE 3—583B WITH ICM FIOP ELECTRICAL DATA

UNIT SIZE 583B	V-PH-HZ	VOLTAGE RANGE		COMPRESSOR		OUTDOOR FAN MOTOR	INDOOR FAN MOTOR	POWER SUPPLY	
		MIN	MAX	RLA	LRA	FLA	FLA	MCA	MAX FUSE OR CKT. BKR.
024	208/230-1-60	187	253	13.5	61.0	0.9	4.3	22.1	30
030	208/230-1-60	187	253	14.7	73.0	0.9	4.3	23.6	30
036	208/230-1-60	187	253	15.4	83.0	0.9	6.8	27.0	35
042	208/230-1-60	187	253	18.6	105.0	0.9	6.8	31.0	40
048	208/230-1-60	187	253	20.5	109.0	1.6	6.8	34.0	40
060	208/230-1-60	187	253	27.6	158.0	1.6	9.2	45.2	60

- f. Loosen set-screw that secures wheel to motor shaft, remove screws that secure motor mount brackets to blower housing, and slide motor and motor mount out of blower housing.
2. Remove and clean blower wheel as follows:
 - a. Ensure proper reassembly by marking wheel orientation.
 - b. Lift wheel from housing. When handling and/or cleaning blower wheel, be sure not to disturb balance weights (clips) on blower wheel vanes.
 - c. Remove caked-on dirt from wheel and housing with a brush. Remove lint and/or dirt accumulations from wheel and housing with vacuum cleaner, using soft brush attachment. Remove grease and oil with mild solvent.
 - d. Reassemble wheel into housing.
 - e. Reassemble motor into housing. Be sure set-screw(s) are tightened on motor shaft flats and not on round part of shaft.
 - f. Pivot blower access panel back into place. Adjust wire assemblies so that wiring follows proper pathways.
 - g. Reinstall unit access panel.
3. Restore electrical power, then gas supply to unit. Start unit and check for proper blower rotation and motor speeds during heating and cooling cycles.

**TROUBLESHOOTING
START-UP CHECKLIST**

TABLE 4—ICM FIOP PHYSICAL DATA—UNIT 683B

THIS DATA APPLIES TO 683B UNITS WITH THE ICM INDOOR MOTOR FIOP							
UNIT SIZE 683B	024040	030040	030060	036060	036090	042060	042090
NOMINAL CAPACITY (ton)	2	2-1/2	2-1/2	3	3	3-1/2	3-1/2
OPERATING WEIGHT (lb.)	310	324	324	321	321	380	380
COMPRESSORS Quantity	Scroll 1						
REFRIGERANT (R-410A) Quantity (lb.)	7.0	8.9	8.9	9.3	9.3	9.5	9.5
REFRIGERANT METERING DEVICE Orifice Indoor (in.) Check-Flo-Rater™ Piston	0.061	0.061	0.061	0.067	0.067	0.073	0.073
REFRIGERANT METERING DEVICE Orifice Outdoor (in.) Check-Flo-Rater™ Piston	0.032 (2)	0.040 (2)	0.040 (2)	0.040 (2)	0.040 (2)	0.038 (2)	0.038 (2)
OUTDOOR COIL Rows...Fins/in. Face Area (sq ft)	2...17 8.5	2...17 10.3	2...17 10.3	2...17 10.3	2...17 10.3	2...17 13.5	2...17 13.5
OUTDOOR FAN Nominal Cfm Diameter (in.) Motor Hp (Rpm)	2350 22 1/8 (825)	2350 22 1/8 (825)	2350 22 1/8 (825)	2500 22 1/4 (1100)	2500 22 1/4 (1100)	2350 22 1/8 (825)	2350 22 1/8 (825)
INDOOR COIL Rows...Fins/in. Face Area (sq ft)	3...15 3.7	3...15 3.7	3...15 3.7	4...15 3.7	4...15 3.7	3...15 4.7	3...15 4.7
INDOOR BLOWER Nominal Airflow (Cfm) Size (in.) Motor (HP)	800 10 X 10 1/2	1000 10 X 10 1/2	1000 10 X 10 1/2	1200 11 X 10 3/4	1200 11 X 10 3/4	1400 11 X 10 3/4	1400 11 X 10 3/4
FURNACE SECTION* Burner Orifice No. (Qty...Drill Size) Natural Gas Burner Orifice No. (Qty...Drill Size) Propane Gas	2...44 2...50	2...44 2...50	2...38 2...46	2...38 2...46	3...38 3...46	2...38 2...46	3...38 3...46
HIGH-PRESSURE SWITCH (psig) Cutout Reset (Auto)	610 ± 15 420 ± 25						
LOSS-OF-CHARGE/LOW-PRESSURE SWITCH (Liquid Line) (psig) Cutout Reset (Auto)	20 ± 5 45 ± 10						
RETURN-AIR FILTERS (in.) Throwaway	20 X 20 X 1	20 X 20 X 1	20 X 20 X 1	20 X 24 X 1	20 X 24 X 1	24 X 30 X 1	24 X 30 X 1

* Based on altitude of 0 to 2000 ft.

TABLE 5—ICM FIOP PHYSICAL DATA—UNIT 683B (CONTINUED)

THIS DATA APPLIES TO 683B UNITS WITH THE ICM INDOOR MOTOR FIOP						
UNIT SIZE 683B	048090	048115	048130	060090	060115	060130
NOMINAL CAPACITY (ton)	4	4	4	5	5	5
OPERATING WEIGHT (lb.)	409	409	409	504	504	504
COMPRESSORS Quantity	Scroll 1					
REFRIGERANT (R-410A) Quantity (lb.)	10.6	10.6	10.6	12.4	12.4	12.4
REFRIGERANT METERING DEVICE Orifice Indoor (in.) Check-Flo-Rater™ Piston	.076	.076	.076	.088	.088	.088
REFRIGERANT METERING DEVICE Orifice Outdoor (in.) Check-Flo-Rater™ Piston	0.046 (2)	0.046 (2)	0.046 (2)	0.052 (2)	0.052 (2)	0.052 (2)
OUTDOOR COIL Rows...Fins/in. Face Area (sq ft)	2...17 13.5	2...17 13.5	2...17 13.5	2...17 15.4	2...17 15.4	2...17 15.4
OUTDOOR FAN Nominal Cfm Diameter (in.) Motor Hp (Rpm)	3300 22 1/4 (1100)	3300 22 1/4 (1100)	3300 22 1/4 (1100)	3300 22 1/4 (1100)	3300 22 1/4 (1100)	3300 22 1/4 (1100)
INDOOR COIL Rows...Fins/in. Face Area (sq ft)	4...15 4.7	4...15 4.7	4...15 4.7	4...15 5.7	4...15 5.7	4...15 5.7
INDOOR BLOWER Nominal Airflow (Cfm) Size (in.) Motor (HP)	1600 11 X 10 3/4	1600 11 X 10 3/4	1600 11 X 10 3/4	1750 11 X 10 1.0	1750 11 X 10 1.0	1750 11 X 10 1.0
FURNACE SECTION* Burner Orifice No. (Qty...Drill Size) Natural Gas Burner Orifice No. (Qty...Drill Size) Propane Gas	3...38 3...46	3...33 3...42	3...31 3...41	3...38 3...46	3...33 3...42	3...31 3...41
HIGH-PRESSURE SWITCH (psig) Cutout Reset (Auto)	610 ± 15 420 ± 25					
LOSS-OF-CHARGE/LOW-PRESSURE SWITCH (Liquid Line) (psig) Cutout Reset (Auto)	20 ± 5 45 ± 10					
RETURN-AIR FILTERS (in.) Throwaway	24 X 30 X 1	24 X 30 X 1	24 X 30 X 1	24 X 30 X 1	24 X 30 X 1	24 X 30 X 1

* Based on altitude of 0 to 2000 ft.

TABLE 6—683B WITH ICM FIOP ELECTRICAL DATA

UNIT SIZE 683B	V-PH-HZ	VOLTAGE RANGE		COMPRESSOR		OUTDOOR FAN MOTOR	INDOOR FAN MOTOR	POWER SUPPLY	
		MIN	MAX	RLA	LRA	FLA	FLA	MCA	MAX FUSE OR CKT. BKR.
024	208/230-1-60	187	253	13.5	61.0	0.9	4.3	22.1	30
030	208/230-1-60	187	253	15.9	73.0	0.9	4.3	25.1	35
036	208/230-1-60	187	253	16.9	83.0	1.6	6.8	29.5	40
042	208/230-1-60	187	253	22.4	105.0	0.9	6.8	35.7	50
048	208/230-1-60	187	253	21.3	109.0	1.6	6.8	35.0	50
060	208/230-1-60	187	253	27.6	158.0	1.6	9.2	45.3	60

SCHEMATIC 208/230-1-60

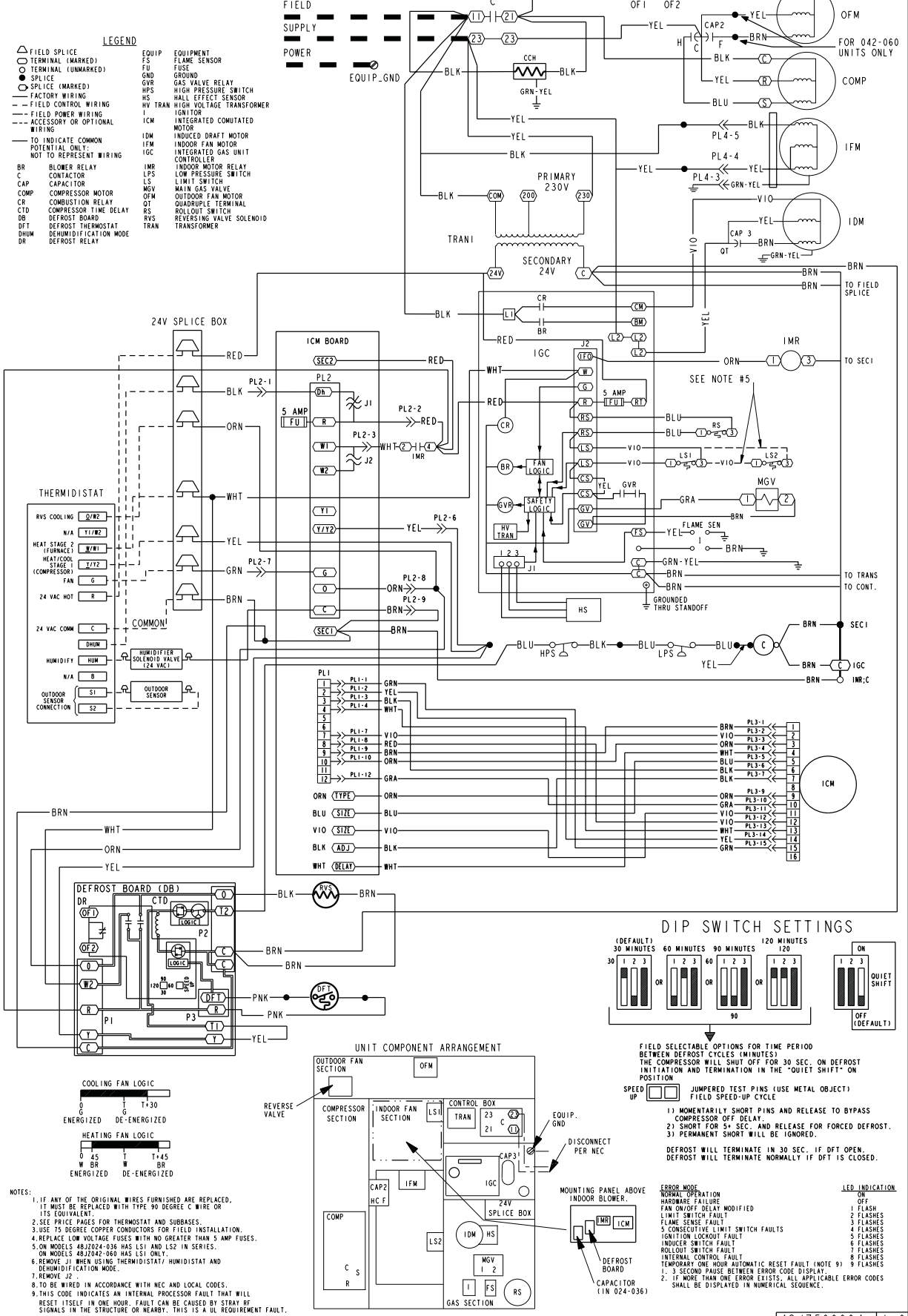

Fig. 15—ICM FIOP Electric Schematic—Unit 683B

TABLE 7—ICM FIOP PHYSICAL DATA—UNIT 702B

THIS DATA APPLIES TO 702B UNITS WITH THE ICM INDOOR MOTOR FIOP						
UNIT SIZE	024	030	036	042	048	060
NOMINAL CAPACITY (ton)	2	2-1/2	3	3-1/2	4	5
OPERATING WEIGHT (lb)	270	291	299	321	326	399
COMPRESSOR	Scroll					
REFRIGERANT (R-410A) Quantity (lb)	5.0	5.5	6.9	9.0	9.5	10.0
REFRIGERANT METERING DEVICE Orifice ID (in.)	Check-Flo-Rater™ Piston					
	.057	.057	.065	.070	.073	.086
CONDENSER COIL Rows...Fins/in. Face Area (sq. ft.)	1...17 10.9	1...17 12.7	2...17 9.1	2...17 12.3	2...17 12.3	2...17 16.4
CONDENSER FAN Nominal Cfm Diameter (in.) Motor Hp (Rpm)	2350 22 1/8 (825)	2350 22 1/8 (825)	2350 22 1/8 (825)	2350 22 1/8 (825)	3300 22 1/4 (1100)	3300 22 1/4 (1100)
EVAPORATOR COIL Rows...Fins/in. Face Area (sq. ft.)	3...15 3.7	3...15 3.7	3...15 3.7	3...15 4.7	4...15 4.7	4...15 4.7
EVAPORATOR BLOWER Nominal Airflow (Cfm) Size (in.) Motor (HP)	800 10x10 1/2	1000 10x10 1/2	1200 10x10 3/4	1400 11x10 3/4	1600 11x10 3/4	2000 11x10 1
HIGH-PRESSURE SWITCH (psig) Cutout Reset (Auto)	610 ± 15 420 ± 25					
LOSS-OF-CHARGE/LOW-PRESSURE SWITCH (Liquid Line) (psig) Cutout Reset (Auto)	20 ± 5 45 ± 10					
RETURN-AIR FILTERS (in.) Throwaway	20 X 20 X 1	20 X 20 X 1	20 X 24 X 1	24 X 30 X 1	24 X 30 X 1	24 X 30 X 1

TABLE 8—702B WITH ICM FIOP ELECTRICAL DATA

UNIT SIZE 702B	V-PH-HZ	VOLTAGE RANGE		COMPRESSOR		OUTDOOR FAN MOTOR	INDOOR FAN MOTOR	ELECTRIC HEAT		SINGLE POINT POWER SUPPLY		
		MIN	MAX	RLA	LRA	FLA	FLA	Nominal kW*	FLA	MCA	MAX FUSE OR CKT. BKR.	MOCP
024	208/230-1-60	187	253	13.5	61.0	0.9	4.3	-/-	-/-	22.1/22.1	30/30	-
								3.8/5.0	18.1/20.8	27.9/31.4	30/35	-
								5.4/7.2	25.9/30.0	37.8/42.9	40/50	-
								7.5/10.0	36.1/41.7	50.5/57.5	60/60	-
030	208/230-1-60	187	253	14.7	73.0	0.9	4.3	-/-	-/-	23.5/23.5	30/30	-
								3.8/5.0	18.1/20.8	27.9/31.4	30/35	-
								5.4/7.2	25.9/30.0	37.8/42.9	40/50	-
								7.5/10.0	36.1/41.7	50.5/57.5	60/60	-
036	208/230-1-60	187	253	15.4	83.0	0.9	6.8	-/-	-/-	27.0/27.0	35/35	-
								3.8/5.0	18.1/20.8	31.1/34.5	35/40	-
								5.4/7.2	25.9/30.0	40.9/46.0	50/50	-
								7.5/10.0	36.1/41.7	53.6/60.6	60/-	-/70
								11.3/15.0	54.2/62.5	76.2/86.6	-	80/90
042	208/230-1-60	187	253	18.6	105.0	0.9	6.8	-/-	-/-	31.0/31.0	40/10	-
								3.8/5.0	18.1/20.8	31.1/34.5	40/40	-
								5.4/7.2	25.9/30.0	40.9/46.0	50/50	-
								7.5/10.0	36.1/41.7	53.6/60.6	60/-	-/70
								11.3/15.0	54.2/62.5	76.2/86.6	-	90/90
048	208/230-1-60	187	253	20.5	109.0	1.6	6.8	-/-	-/-	34.0/34.0	40/40	-
								3.8/5.0	18.1/20.8	34.0/34.5	40/40	-
								5.4/7.2	25.9/30.0	40.9/46.0	50/50	-
								7.5/10.0	36.1/41.7	53.6/60.6	60/-	-/70
								11.3/15.0	54.2/62.5	76.2/86.6	-	90/90
060	208/230-1-60	187	253	27.6	158.0	1.6	9.1	-/-	-/-	45.2/45.2	60/60	-
								3.8/5.0	18.1/20.8	45.2/45.2	60/60	-
								5.4/7.2	25.9/30.0	43.8/48.9	50/50	-
								7.5/10.0	36.1/41.7	56.5/63.5	60/-	-/70
								11.3/15.0	54.2/62.5	79.1/89.5	-	90/90
								15.0/20.0	72.2/83.3	101.6/115.5	-	110/125

* Heater capacity (kW) based on heater voltage of 208-v & 240-v. If power distribution voltage to unit varies from rated heater voltage, heater kW will vary accordingly. Refer to *Multiplication Factors* Table 23.

TABLE 9—ICM FIOP PHYSICAL DATA—UNIT 602B

THIS DATA APPLIES TO 602B UNITS WITH THE ICM INDOOR MOTOR FIOP						
UNIT SIZE	602B024	602B030	602B036	602B042	602B048	602B060
NOMINAL CAPACITY (ton)	2	2-1/2	3	3-1/2	4	5
OPERATING WEIGHT (lb.)	299	320	328	350	355	428
COMPRESSOR QUANTITY	1					
TYPE	SCROLL COMPRESSOR					
REFRIGERANT	R-410A					
REFRIGERANT METERING DEVICE	Check-Flo-Rater™					
Refrigerant (R-410A) Quantity (lb.)	7.0	8.9	9.3	9.5	10.6	12.4
ORIFICE ID (in.)	0.061	0.061	0.067	0.073	0.076	0.088
ORIFICE OD (in.)	0.032 (2)	0.040 (2)	0.040 (2)	0.038 (2)	0.046 (2)	0.052 (2)
OUTDOOR COIL Rows... Fins/in. face area (sq. ft.)	2...17 8.5	2...17 10.3	2...17 10.3	2...17 13.5	2...17 13.5	2...17 15.4
OUTDOOR FAN Nominal Airflow (CFM) Diameter Motor HP (RPM)	2350 22 1/8 (825)	2350 22 1/8 (825)	2800 22 1/4 (1100)	2500 22 1/8 (825)	3300 22 1/4 (1100)	3300 22 1/4 (1100)
INDOOR COIL Rows... Fins/in. face area (sq. ft.)	3...15 3.7	3...15 3.7	4...15 3.7	3...15 4.7	4...15 4.7	4...15 5.7
INDOOR BLOWER Nominal Airflow (CFM) Size (in.) Motor (HP)	800 10 X 10 1/2	1000 10 X 10 1/2	1200 10 X 10 3/4	1400 11 X 10 3/4	1600 11 X 10 3/4	2000 11 X 10 1
HIGH-PRESSURE SWITCH (psig) Cutout Reset (Auto)	610 ± 15 420 ± 25					
LOSS-OF-CHARGE/LOW-PRESSURE SWITCH (Liquid Line) (psig) Cutout Reset (Auto)	20 ± 5 45 ± 10					
RETURN-AIR FILTERS (in.) throwaway	20 X 20 X 1	20 X 20 X 1	20 X 24 X 1	24 X 30 X 1	24 X 30 X 1	24 X 30 X 1

TABLE 10—602B WITH ICM FIOP ELECTRICAL DATA

UNIT SIZE 602B	V-PH-HZ	VOLTAGE RANGE		COMPRESSOR		OUTDOOR FAN MOTOR	INDOOR FAN MOTOR	ELECTRIC HEAT		SINGLE POINT POWER SUPPLY		
		MIN	MAX	RLA	LRA	FLA	FLA	Nominal kW*	FLA	MCA	MAX FUSE OR CKT. BKR.	MOCP
024	208/230-1-60	187	253	13.5	61.0	0.9	4.3	-/-	-/-	22.1/22.1	30/30	-
								3.8/5.0	18.1/20.8	44.6/48.1	50/50	-
								5.4/7.2	25.9/30.0	54.5/59.6	60/-	-70
								7.5/10.0	36.1/41.7	67.2/74.2	-	70/80
030	208/230-1-60	187	253	15.9	73.0	0.9	4.3	-/-	-/-	25.1/25.1	30/30	-
								3.8/5.0	18.1/20.8	47.6/51.1	60/60	-
								5.4/7.2	25.9/30.0	57.4/62.6	-	70/70
								7.5/10.0	36.1/41.7	70.2/77.2	-	80/80
								11.3/15.0	54.2/62.5	92.8/103.2	-	100/110
036	208/230-1-60	187	253	16.9	83.0	1.6	6.8	-/-	-/-	29.5/29.5	40/40	-
								3.8/5.0	18.1/20.8	52.1/55.6	60/60	-
								5.4/7.2	25.9/30.0	61.9/67.0	-	70/80
								7.5/10.0	36.1/41.7	74.7/81.6	-	80/90
								11.3/15.0	54.2/62.5	97.2/107.7	-	100/110
042	208/230-1-60	187	253	22.4	105.0	0.9	6.8	-/-	-/-	35.7/35.7	50/50	-
								3.8/5.0	18.1/20.8	58.3/61.7	-	70/70
								5.4/7.2	25.9/30.0	68.1/73.2	-	80/80
								7.5/10.0	36.1/41.7	80.8/87.8	-	90/90
								11.3/15.0	54.2/62.5	103.4/113.0	-	110/125
048	208/230-1-60	187	253	21.3	109.0	1.6	6.8	-/-	-/-	35.0/35.0	50/50	-
								3.8/5.0	18.1/20.8	57.6/61.1	-	70/70
								5.4/7.2	25.9/30.0	67.4/72.5	-	80/80
								7.5/10.0	36.1/41.7	80.2/87.1	-	90/90
								11.3/15.0	54.2/62.5	102.7/113.2	-	110/125
060	208/230-1-60	187	253	27.6	158.0	1.6	9.2	-/-	-/-	45.1/45.1	60/60	-
								3.8/5.0	18.1/20.8	67.7/71.1	-	80/80
								5.4/7.2	25.9/30.0	77.7/82.8	-	90/90
								7.5/10.0	36.1/41.7	90.2/97.2	-	100/110
								11.3/15.0	54.2/62.5	112.8/123.2	-	125/125
								15.0/20.0	72.2/83.3	135.4/149.3	-	150/150

* Heater capacity (kW) based on heater voltage of 208-v & 240-v. If power distribution voltage to unit varies from rated heater voltage, heater kW will vary accordingly. Refer to *Multiplication Factors* Table 23.

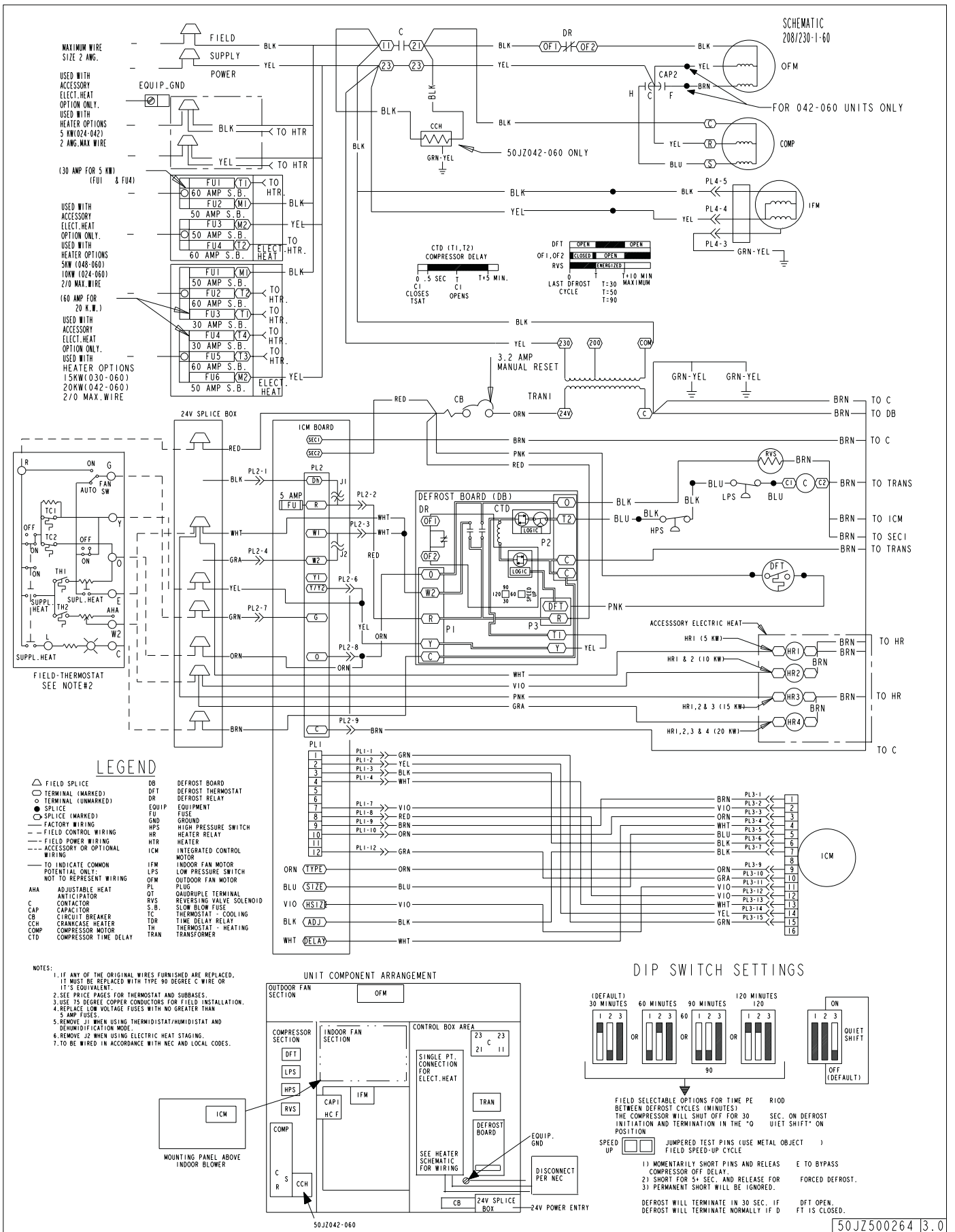

Fig. 17—ICM FOP Electrical Schematic—602B

**TABLE 11—583B & 683B COOLING (AND HEAT PUMP HEATING-683B ONLY)
 DRY COIL ICM AIRFLOW
 SMALL CABINET**

UNIT SIZE	CFM ADJUST PIN SELECT	LO PIN			NOM PIN			HI PIN		
	EXTERNAL STATIC PRESSURE RANGE	0.0–0.4	0.4–0.7	0.7–1.0	0.0–0.4	0.4–0.7	0.7–1.0	0.0–0.4	0.4–0.7	0.7–1.0
024	COOLING †	745	675	–	835	750	690	940	880	815
	COOLING DEHUMIDIFY	675	625	–	675	650	600	755	730	705
	HEAT PUMP COMFORT (683B Only)	670	605	–	740	690	635	845	795	735
030	COOLING †	940	860	785	1020	965	895	1185	1100	1010
	COOLING DEHUMIDIFY	820	785	735	820	800	770	955	920	880
	HEAT PUMP COMFORT (683B Only)	850	780	745	935	905	845	1055	1040	955
036	COOLING †	1025	935	–	1145	1085	1005	1320	1260	1180
	COOLING DEHUMIDIFY	925	885	–	925	900	870	1060	1040	1010
	HEAT PUMP COMFORT (683B Only)	955	880	–	1075	990	920	1220	1180	1125

† On 683B Only Heat Pump Efficiency and Cooling pin selections deliver equal airflow

**TABLE 12—583B & 683B COOLING (AND HEAT PUMP HEATING-683B ONLY)
 DRY COIL ICM AIRFLOW
 LARGE CABINET**

UNIT SIZE	CFM ADJUST PIN SELECT	LO PIN	NOM PIN	HI PIN
	EXTERNAL STATIC PRESSURE RANGE	0.1–1.0	0.1–1.0	0.1–1.0
042	COOLING †	1100	1225	1410
	COOLING DEHUMIDIFY	980	980	1125
	HEAT PUMP COMFORT (683B Only)	990	1100	1265
048	COOLING †	1260	1400	1610
	COOLING DEHUMIDIFY	1120	1120	1290
	HEAT PUMP COMFORT (683B Only)	1135	1260	1450
060	COOLING †	1575	1750	2010
	COOLING DEHUMIDIFY	1400	1400	1610
	HEAT PUMP COMFORT (683B Only)	1415	1575	1810

† On 683B Only Heat Pump Efficiency and Cooling pin selections deliver equal airflow

**TABLE 13—583B & 683B GAS HEATING ICM AIRFLOW
 SMALL CABINET**

EASY SELECT™ BOARD SETTING (CFM)		700			800			1100			1250		
Unit Size	External Static Pressure	0.0–0.4	0.4–0.7	0.7–1.0	0.0–0.4	0.4–0.7	0.7–1.0	0.0–0.4	0.4–0.7	0.7–1.0	0.0–0.4	0.4–0.7	0.7–1.0
	Gas Heat Size												
024	040	–	–	–	855	770	710	–	–	–	–	–	–
	060	–	–	–	–	–	–	1020	890	835	–	–	–
030	040	–	–	–	880	840	805	–	–	–	–	–	–
	060	–	–	–	–	–	–	1030	970	910	–	–	–
036	060	–	–	–	–	–	–	1035	995	955	–	–	–
	090	–	–	–	–	–	–	–	–	–	1170	1110	1025

**TABLE 14—583B & 683B GAS HEATING ICM AIRFLOW
LARGE CABINET**

EASY SELECT™ BOARD SETTING (CFM)		1000	1250	1600	1750	1800
Unit Size	External Static Pressure	0.0–1.0	0.0–1.0	0.0–1.0	0.0–1.0	0.0–1.0
	Gas Heat Size					
042	060	1000	–	–	–	–
	090	–	1250	–	–	–
048	090	–	1250	–	–	–
	115	–	–	1600	–	–
	130	–	–	–	1750	–
060	090	–	1250	–	–	–
	115	–	–	1600	–	–
	130	–	–	–	–	1800

TABLE 15—583B & 683B ICM AIR FLOW VS. TEMPERATURE RISE CHART

UNIT	COOLING SIZE	RATED GAS INPUT RATE (X 1000)	AIRFLOW SETTING EASY SELECT™ (SCFM)	CALCULATED TEMPERATURE RISE	MIN. TEMP RISE	MAX TEMP RISE	MAX DISCH. TEMP
583B & 683B	024	40	800	36.5	20	50	175
		60 (583B Only)	1100	40	35	65	165
	030	40	800	36.5	20	50	175
		60	1100	40	35	65	165
	036	60	1100	40	25	55	165
		90	1200	54	45	75	175
	042	60	1000	44	20	50	165
		90	1250	53	35	65	170
	048	90	1250	53	25	55	165
		115	1600	53	35	65	170
		130	1750	54	40	70	175
	060	90	1600	41	25	55	155
		115	1600	53	35	65	170
		130	1800	53	40	70	175

**TABLE 16—702B/602B COOLING & HEATING DRY COIL ICM AIRFLOW
SMALL CABINET**

UNIT SIZE	CFM ADJUST PIN SELECT	LO PIN			NOM PIN			HI PIN		
	EXTERNAL STATIC PRESSURE RANGE	0.0–0.4	0.4–0.7	0.7–1.0	0.0–0.4	0.4–0.7	0.7–1.0	0.0–0.4	0.4–0.7	0.7–1.0
024	COOLING †	800	725	–	885	805	730	990	930	855
	COOLING DEHUMIDIFY	715	670	–	715	695	645	795	775	745
	HEAT PUMP COMFORT (602B Only)	720	660	–	790	745	685	890	850	785
030	COOLING †	1010	920	825	1105	1030	930	1255	1160	1050
	COOLING DEHUMIDIFY	890	845	795	890	865	825	1010	980	925
	HEAT PUMP COMFORT (602B Only)	945	850	765	1020	965	895	1140	1105	995
036	COOLING †	1110	1025	970	1235	1175	1115	1400	1355	1280
	COOLING DEHUMIDIFY	990	960	910	990	975	940	1125	1110	1085
	HEAT PUMP COMFORT (602B Only)	1035	975	910	1160	1080	1020	1305	1275	1220

† Heat Pump Efficiency and Cooling pin selections deliver equal airflow

**TABLE 17—702B/602B COOLING & HEATING DRY COIL ICM AIRFLOW
LARGE CABINET**

UNIT SIZE	CFM ADJUST PIN SELECT	LO PIN	NOM PIN	HI PIN
	EXTERNAL STATIC PRESSURE RANGE	0.1–1.0	0.1–1.0	0.1–1.0
042	COOLING †	1100	1225	1410
	COOLING DEHUMIDIFY	980	980	1125
	HEAT PUMP COMFORT (602B Only)	990	1100	1265
048	COOLING †	1260	1400	1610
	COOLING DEHUMIDIFY	1120	1120	1290
	HEAT PUMP COMFORT (602B Only)	1135	1260	1450
060	COOLING †	1575	1750	2010
	COOLING DEHUMIDIFY	1400	1400	1610
	HEAT PUMP COMFORT (602B Only)	1415	1575	1810

† Heat Pump Efficiency and Cooling pin selections deliver equal airflow

TABLE 18—MINIMUM AIRFLOW FOR RELIABLE ELECTRIC HEATER OPERATION (CFM)

UNIT SIZE	024	030	036	042	048	060
602B	750	1025	1250	1285	1710	1800
702B	750	750	1250	1205	1500	1800

**TABLE 19—ELECTRIC HEAT PRESSURE DROP TABLE (IN. WG)
SMALL CABINET**

STATIC	CFM											
	500	600	700	800	900	1000	1100	1200	1300	1400	1500	1600
5 kW	0.00	0.00	0.00	0.00	0.00	0.00	0.00	0.00	0.02	0.04	0.06	0.07
7.5 kW	0.00	0.00	0.00	0.00	0.00	0.00	0.02	0.03	0.05	0.07	0.08	0.09
10 kW	0.00	0.00	0.00	0.00	0.00	0.02	0.04	0.06	0.07	0.09	0.10	0.11
15 kW	0.00	0.00	0.00	0.02	0.04	0.06	0.08	0.10	0.12	0.14	0.16	0.18
20 kW	0.00	0.00	0.02	0.04	0.06	0.08	0.09	0.11	0.13	0.15	0.17	0.19

**TABLE 20— ELECTRIC HEAT PRESSURE DROP TABLE (IN. WG)
LARGE CABINET**

STATIC	CFM														
	1100	1200	1300	1400	1500	1600	1700	1800	1900	2000	2100	2200	2300	2400	2500
5 kW	0.00	0.00	0.00	0.01	0.02	0.03	0.04	0.05	0.06	0.07	0.08	0.09	0.10	0.11	0.12
7.5 kW	0.00	0.00	0.01	0.02	0.03	0.04	0.05	0.06	0.07	0.08	0.09	0.10	0.11	0.12	0.13
10 kW	0.00	0.00	0.01	0.02	0.03	0.04	0.05	0.06	0.07	0.08	0.09	0.10	0.11	0.12	0.13
15 kW	0.00	0.02	0.03	0.04	0.05	0.06	0.07	0.08	0.09	0.10	0.11	0.12	0.13	0.14	0.15
20 kW	0.02	0.03	0.04	0.05	0.06	0.07	0.08	0.09	0.10	0.11	0.12	0.13	0.14	0.15	0.16

TABLE 21—ICM FIOP WET COIL PRESSURE DROP (IN. WG)

UNIT SIZE	STANDARD CFM (SCFM)															
	600	700	800	900	1000	1100	1200	1300	1400	1500	1600	1700	1800	1900	2000	2100
024	0.005	0.007	0.010	0.012	0.015	—	—	—	—	—	—	—	—	—	—	—
030	—	0.007	0.010	0.012	0.015	0.018	0.021	0.024	—	—	—	—	—	—	—	—
036	—	—	—	0.019	0.023	0.027	0.032	0.037	0.042	0.047	—	—	—	—	—	—
042	—	—	—	—	0.014	0.017	0.020	0.024	0.027	0.031	0.035	0.039	0.043	—	—	—
048	—	—	—	—	—	—	0.027	0.032	0.036	0.041	0.046	0.052	0.057	0.063	0.068	—
060	—	—	—	—	—	—	—	—	—	0.029	0.032	0.036	0.040	0.045	0.049	0.053

TABLE 22—FILTER PRESSURE DROP TABLE (IN. WG)

FILTER SIZE	CFM																		
	500	600	700	800	900	1000	1100	1200	1300	1400	1500	1600	1700	1800	1900	2000	2100	2200	2300
20 X 20 X 1	0.05	0.07	0.08	0.10	0.12	0.13	0.14	0.15	—	—	—	—	—	—	—	—	—	—	—
20 X 24 X 1	—	—	—	—	0.09	0.10	0.11	0.13	0.14	0.15	0.16	—	—	—	—	—	—	—	—
24 X 30 X 1	—	—	—	—	—	—	—	0.07	0.08	0.09	0.10	0.11	0.12	0.13	0.14	0.15	0.16	0.17	0.18

TABLE 23—ELECTRIC HEATER MULTIPLICATION FACTORS

HEATER KW RATING	VOLTAGE DISTRIBUTION	MULTIPLICATION FACTOR
240	200	.69
	208	.75
	230	.92
	240	1.00

Example:
 15.0 kW (at 240-v.) heater on 208-v.
 = 15.0 (.75 mult. factor)
 = 11.25 capacity at 208-v.

QUICK REFERENCE GUIDE

SET-UP INSTRUCTIONS FOR WARMER HEATING TEMPERATURES AND SUPER HUMIDITY CONTROL IN COOLING

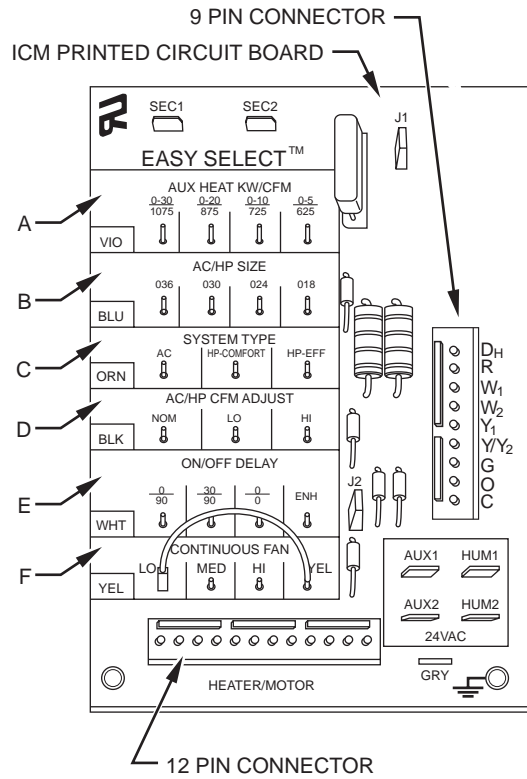

EASY SELECT BOARD

1. Configuration Taps
(See Installation Instructions, for detailed description.)
 - A. AUX HEAT - Set for heater size (Ex: 0-10 for 10 kw)
 - B. AC/HP SIZE - Set for size of outdoor unit
 - C. SYSTEM TYPE - Select "HP COMFORT"
 - D. AC/HP CFM ADJUST - Select "LO"
 - E. ON/OFF DELAY - Select "ENH"
 - F. CONTINUOUS FAN - Select desired speed
2. Remove Jumper J1 to activate all dehumidify modes.
3. Complete wiring and install outdoor temperature sensor according to Installation Instructions.

THERMIDISTAT™ CONTROL SETTINGS

1. Set "DIP Switches" - Set the dip switches (back of Thermidistat Control Board) appropriately for specific system being installed.
2. Thermidistat Control Configurations
(See Thermidistat™ Control Installation Instructions for detailed description.)
 - Option 5 (Variable Speed Motors) - set to ON
 - Option 7 (Super Dehumidify) - set to ON
 - Option 12 (Heaters during Defrost) - setting "2" is suggested for all heaters
 - Option 16 - Heat pump systems set to ON for warmer heat below 40° F.
 - Option 17 - Select programmable or non-programmable mode.
3. Set desired humidity level on front of Thermidistat (50 to 55% RH recommended). For dehumidification in cooling, both "dhu" and "cool" must be displayed.

c01034

ICM QUICK REFERENCE GUIDE

TABLE 24—TROUBLESHOOTING CHART

SYSTEM	CAUSE	REMEDY
IFM does not run	Blower wheel not secured to shaft	Inspect and properly tighten blower wheel to shaft
	Insufficient voltage at motor	Determine cause and correct
	Power connectors not properly seated	Connectors should snap easily; do not force
IFM operation is intermittent	Connectors not firmly seated	Gently pull wires individually to be sure they are inserted into the connectors

START-UP CHECKLIST (Remove and Store in Job File)

I. Preliminary Information

MODEL NO.: _____
 SERIAL NO.: _____
 DATE: _____
 TECHNICIAN: _____

II. PRE-START-UP (Insert checkmark in box as each item is completed)

- VERIFY THAT ALL PACKING MATERIALS HAVE BEEN REMOVED FROM UNIT
- REMOVE ALL SHIPPING HOLD DOWN BOLTS AND BRACKETS PER INSTALLATION INSTRUCTIONS
- CHECK ALL ELECTRICAL CONNECTIONS AND TERMINALS FOR TIGHTNESS
- CHECK GAS PIPING FOR LEAKS (WHERE APPLICABLE)
- CHECK THAT INDOOR (EVAPORATOR) AIR FILTER IS CLEAN AND IN PLACE
- VERIFY THAT UNIT INSTALLATION IS LEVEL
- CHECK FAN WHEEL, AND PROPELLER FOR LOCATION IN HOUSING/ORIFICE AND SETSCREW TIGHTNESS
- MAKE SURE THAT - ON 060 SIZE PURON HEATPUMP, ONLY-THE TWO WIRE TIES FASTEN TO THE OUTDOOR COILS AND REVERSING VALVE/ACCUMULATOR HAVE BEEN REMOVED.

III. START-UP

ELECTRICAL

SUPPLY VOLTAGE _____
 COMPRESSOR AMPS _____
 INDOOR (EVAPORATOR) FAN AMPS _____

TEMPERATURES

OUTDOOR (CONDENSER) AIR TEMPERATURE _____ DB
 RETURN-AIR TEMPERATURE _____ DB _____ WB
 COOLING SUPPLY AIR _____ DB _____ WB
 HEAT PUMP SUPPLY AIR _____
 GAS HEAT SUPPLY AIR _____
 ELECTRIC HEAT SUPPLY AIR _____

PRESSURES

GAS INLET PRESSURE _____ IN. WG
 GAS MANIFOLD PRESSURE _____ IN. WG
 REFRIGERANT SUCTION _____ PSIG SUCTION LINE TEMP* _____
 REFRIGERANT DISCHARGE _____ PSIG DISCHARGE TEMP† _____

- VERIFY REFRIGERANT CHARGE USING CHARGING CHARTS

GAS HEAT TEMPERATURE RISE
 TEMPERATURE RISE (LITERATURE) RANGE _____
 MEASURED TEMPERATURE RISE _____

*Measured at suction inlet to compressor
 †Measured at liquid line leaving condenser.

IV. EASY SELECT SETTINGS

FULL UNIT MODEL NUMBER: _____
 ENTER AVAILABLE HEATSETTINGS _____
 ENTER AVAILABLE AIRFLOW HEAT AIR PIN CONNECTION SETTING _____
 ENTER AVAILABLE SIZES SIZE PIN CONNECTION SETTING _____
 TYPE PIN CONNECTION SETTING _____
 ADJUST PIN CONNECTION SETTING _____
 DELAY PIN CONNECTION SETTING _____
 (0/0 or 0/90 for gas/electric models)
 CONTINUOUS FAN PIN CONNECTION SETTING _____

EASY SELECT			
Heat Settings			
AC HP Size			
System Type			
AC	HP-Comfort	HP.Eff	
AC/HP CFM Adjust			
Norm	Lo	Hi	
On/Off Delay			
% ₀	³⁰ % ₀	%	ENH
Continous Fan			
Lo	Med	Hi	

