

WELL™

WIRELESS EVENT LED LUMINAIRE

User Manual

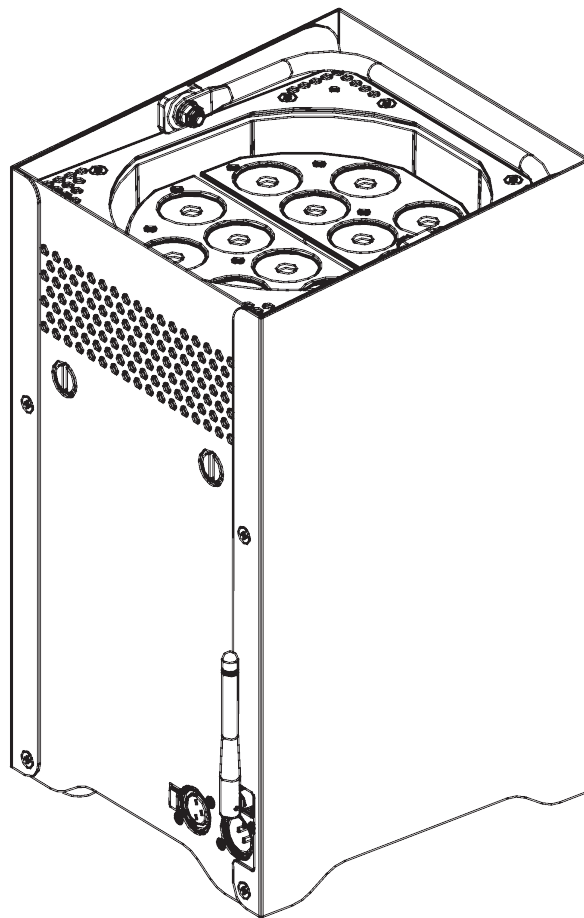

CHAUVET[®]
PROFESSIONAL

Edition Notes

The WELL User Manual Rev. 01e covers the description, safety precautions, installation, programming, operation, and maintenance of the WELL fixture. CHAUVET® released this edition of the WELL User Manual in May 2011.

Trademarks

CHAUVET® is a registered trademark of CHAUVET & Sons Inc. (d/b/a CHAUVET® or Chauvet). The CHAUVET® logo in its entirety including the Chauvet name and the dotted triangle, and all other trademarks on this manual pertaining to services, products, or marketing statements (example: It's Green Thinking™) are owned or licensed by CHAUVET®. Any other product names, logos, brands, company names, and other trademarks featured or referred to within this document are the property of their respective trademark holders.

Copyright Notice

CHAUVET® owns the content of this user manual in its entirety, including but not limited to pictures, logos, trademarks, and resources.

© Copyright 2011 CHAUVET®. All rights reserved

Electronically published by CHAUVET® in the United States of America

Manual Usage

CHAUVET® authorizes its customers to download and print this manual for professional information purposes only. CHAUVET® expressly prohibits the usage, copy, storage, distribution, modification, or printing of this manual or its content for any other purpose without its written consent.

Document Printing

For better results, print this document in color, on letter size paper (8.5 x 11 inches), double sided. If using A4 paper (210 x 297 mm), configure your printer to scale the content accordingly.

Intended Audience

Any person in charge of installing, operating, and/or maintaining this product should read the guide that shipped with it as well as this manual in their entirety before installing, operating, or maintaining this product.

Disclaimer

CHAUVET® believes that the information contained in this manual is accurate in all respects. However, CHAUVET® assumes no responsibility for any error or omissions in this document. CHAUVET® reserves the right to revise this document and to make changes from time to time in the content hereof without obligation of CHAUVET® to notify any person or company of such revision or changes. This does not constitute in any way a commitment by CHAUVET® to make such changes. CHAUVET® may issue a revision of this manual or a new edition of it to incorporate such changes.

CHAUVET® Publications Hot Line

If you have any comments about the accuracy of this document or general suggestions regarding how we can improve it, please call us at (800) 762-1084 (US callers) or +1-954-929-1115 (international callers). You can download the latest versions of all CHAUVET® products' manuals from www.chauvetlighting.com.

Document Revision

The WELL User Manual Rev. 01e supersedes all previous versions of this manual. Please discard any older versions of this manual you may have, whether in printed or electronic format, and replace them with this version.

Author	Editor	Manager	PD Manager
O. Desmonteix	D. Coupee	M. Graham	F. Sellers

Table of Contents

1. Before You Begin	1
What is Included	1
Unpacking Instructions	1
Typographic Conventions	1
Icon Meaning	1
Product at a Glance	1
Safety Notes	2
Expected LED Lifespan	2
2. Introduction	3
Product Description	3
Features	3
Options	3
DMX Channel Summary	4
Product Overview	5
Product Dimensions	6
3. Setup	7
AC Power	7
AC Plug	7
Fuse	7
DMX Linking	7
DMX Modes	7
Master/Slave Connectivity	8
Mounting	8
Orientation	8
Rigging	8
4. Operation	9
Operation Notes	9
Turning Unit On	9
Turning Unit Off	9
Tilt Angle	9
LEDs Angle	9
Storage Notes	9
Battery Charge Notes	10
Connection Warnings	10
Wireless Operation	11
Initial Setup	11
Configuration	11
Fixture Pairing	11
Control Panel Description	12
Control Options	12
Programming	12
DMX Personality	12
DMX Control	12
Static Color	13
Auto Programs	13
Edit Customs	13
Master/Slave	13
Color Setting	14
Dimmer Curves	14
Control Panel Lock	14
Color Macro Adjustment	14
RGB to White Adjustment	15
Battery Life	15

Table of Contents

<i>Program Upload</i>	15
<i>Reset</i>	16
TOUR Notes	16
<i>Master Dimmer</i>	16
<i>Red, Green, and Blue Color Selection</i>	16
<i>Color Macros</i>	16
<i>Strobe</i>	16
<i>Auto/Custom</i>	16
<i>Dimmer Speed</i>	16
Menu Map	17
DMX Values	18
<i>TOUR</i>	18
<i>ARC.1</i>	19
<i>AR1.D</i>	19
<i>AR1.S</i>	19
<i>HSV</i>	19
<i>BLOC</i>	19
5. Technical Information	20
Fixture Maintenance.....	20
Troubleshooting Guide.....	21
Returns Procedure.....	22
Claims	22
Contact Us.....	22
Technical Specifications.....	23

1. Before You Begin

What is Included

Single Unit:

- One WELL fixture
- One battery charger
- Warranty Card
- Quick Reference Guide

Six-piece Set:

- Six WELL fixtures
- One six-bay flight case with built-in battery charger
- Warranty Card
- Quick Reference Guide

Unpacking Instructions



Immediately upon receiving this product, carefully unpack it and check the container in which you received it. Make sure that you have received all the parts indicated above and that they are all in good condition. If the material inside the container (this product and any other accessory included with it) appears damaged from shipping, or if the container shows signs of mishandling, notify the shipper immediately. In addition, retain the container and all the packing material for inspection.

See the *Claims* section in the *Technical Information* chapter.

Typographic Conventions

Convention	Meaning
1~512	A range of values in the text
50/60	A set of mutually exclusive values in the text
<i>Claims</i>	A new term, or a section or chapter in this document
“COLORado™ 1 UM”	The name of another publication or manual
<SET>	A button on the fixture’s control panel
Settings	A fixture function or a menu option
MENU > Settings	A sequence of menu options
1~10	A range of menu values from which to choose in a menu
Yes/No	A set of two mutually exclusive menu options in a menu
ON	A unique value to entered or select in a menu

Icon Meaning

Icon	Meaning
	This icon indicates critical installation, configuration, or operation information. Failure to comply with this information may render the fixture partially or completely inoperative, damage third-party equipment, or cause harm to the user.
	This icon indicates important installation or configuration information. Failure to comply with this information may prevent the fixture from functioning correctly.
	This icon indicates useful, although non-critical information.



The term “DMX” used throughout this document refers to the USITT DMX512-A transmission protocol.

Product at a Glance

Use on Dimmer	X	Auto Programs	P
Outdoor Use (IP44)	P	Auto-ranging battery charger	P
Sound Activated	X	Replaceable Fuse	X
DMX	P	User Serviceable	X
Master/Slave	P	Duty Cycle	X

Before You Begin

Safety Notes

Please read the following notes carefully because they include important safety information about the installation, usage, and maintenance of this product. It is important to read all these notes before starting to work with this product.



There are no user serviceable parts inside this product. Any reference to servicing it you may find from now on in this User Manual will only apply to properly CHAUVET® certified technicians. Do not open the housing or attempt any repairs unless you are one of them.



Please refer to all applicable local codes and regulations for the proper installation of this product.

Personal Safety

- Avoid direct eye exposure to the light source while the fixture is on.
- Always disconnect this product from its battery charger and turn the battery switch off before servicing.
- Always connect this product's battery charger to a grounded circuit to avoid the risk of electrocution.
- Do not touch this product's housing when operating because it may be hot.

Mounting and Rigging

- Do not submerge this product or subject it to water jets (IP44). Regular outdoor operation under light rain or splashing water is fine.
- Do not hang this product, as this is a floor-standing fixture.
- Do not tilt this product further than 10°.
- Always carry this product using the built-in handle.
- Do not leave any flammable material within 50 cm of this product while operating or recharging the battery.

Power and Wiring

- Always make sure that you are connecting this product's battery charger to the proper voltage, as per the specifications in this manual or on the product's sticker.
- Never connect this product's battery charger to a dimmer pack or rheostat.
- Never disconnect this product's battery charger by pulling or tugging on the power cable.

Operation

- Do not operate this fixture if you see damage on the housing, lenses, or cables. In any of these cases, have the damaged parts replaced by an authorized technician at once.
- Do not cover the ventilation slots when the fixture is operating to avoid internal overheating.
- The maximum ambient temperature (Ta) is 104° F (40° C). Do not operate this product at a higher temperature.
- Do not close the flight case/charger lid when during charging.
- In case of a serious operating problem, stop using this product immediately!



In the unlikely event that your CHAUVET® product may require service, please contact CHAUVET® Technical Support.

Expected LED Lifespan

LEDs gradually decline in brightness over time, mostly because of heat. Packaged in clusters, LEDs exhibit higher operating temperatures than in ideal, single LED conditions. For this reason, using clustered LEDs at their fullest intensity significantly reduces the LEDs' lifespan. Under normal conditions, this lifespan can be of 40,000 to 50,000 hours. If extending this lifespan is vital, lower the operational temperature by improving the fixture's ventilation and reducing the external temperature. In addition, limiting the overall projection intensity may also help to extend the LEDs' lifespan.

2. Introduction

Product Description

The WELL (Wireless Event Light Luminaire) is a battery powered, portable upward wash light. It consists of a single unit that contains the 12 V gel battery, the LEDs, the LED drivers, and the main control. The battery provides up to 12 hours of runtime.

When purchased as a single unit, it comes with an external battery charger. When purchased as a 6-piece set, they come with a flight case that has six storage bays and a built-in charger. Each storage bay in the flight case has its own battery charging connector. This allows recharging all six WELL units simultaneously while in the flight case.

Features

- 3, 4, 5, 6, or 12-channel tri-color RGB LED upward wash light
- Operating modes:
 - 3-channel: Hue, saturation, value control (HSV)
 - 3-channel: RGB control (ARC.1)
 - 4-channel: RGB, dimmer (AR1.D)
 - 5-channel: RGB, dimmer, strobe (AR1.S)
 - 6-channel: RGB control of each module (BLOCK)
 - 12-channel: RGB control of each module, dimmer, color macro, strobe, auto/custom, auto speed, dimmer speed (TOUR)
- Tri-color LEDs
- Five distinct dimming curves
- 3-pin DMX input and output connectors
- Wireless DMX receiver built-in
- LED display with password protection
- Split LED panel for individual focusing
- 12-hour battery life
- Movable foot on base of fixture for added positioning options
- Color calibration
- RGB color mixing with or without DMX control
- Color temperature presets (3,200–10,000 K)
- Built-in automated programs via DMX
- Customizable programs
- Recall custom and auto programs via DMX

Options

- Six-bay flight case/battery charger (empty)
- Stand-alone single unit battery charger
- W-DMX (Wireless DMX) transmitter

DMX Channel Summary

Tour	DMX Channel	Function
	1	Master Dimmer
	2	Module 1 Red
	3	Module 1 Green
	4	Module 1 Blue
	5	Module 2 Red
	6	Module 2 Green
	7	Module 2 Blue
	8	Color Macro + White Balance
	9	Strobe
	10	Auto + Custom Programs
	11	Auto Speed
	12	Dimmer Speed
ARC.1	DMX Channel	Function
	1	Red
	2	Green
	3	Blue
AR1.D	DMX Channel	Function
	1	Master Dimmer
	2	Red
	3	Green
	4	Blue
AR1.S	DMX Channel	Function
	1	Master Dimmer
	2	Red
	3	Green
	4	Blue
	5	Strobe
HSV	DMX Channel	Function
	1	Hue
	2	Saturation
	3	Value
BLOC	DMX Channel	Function
	1	Module 1 Red
	2	Module 1 Green
	3	Module 1 Blue
	4	Module 2 Red
	5	Module 2 Green
	6	Module 2 Blue

Product Overview

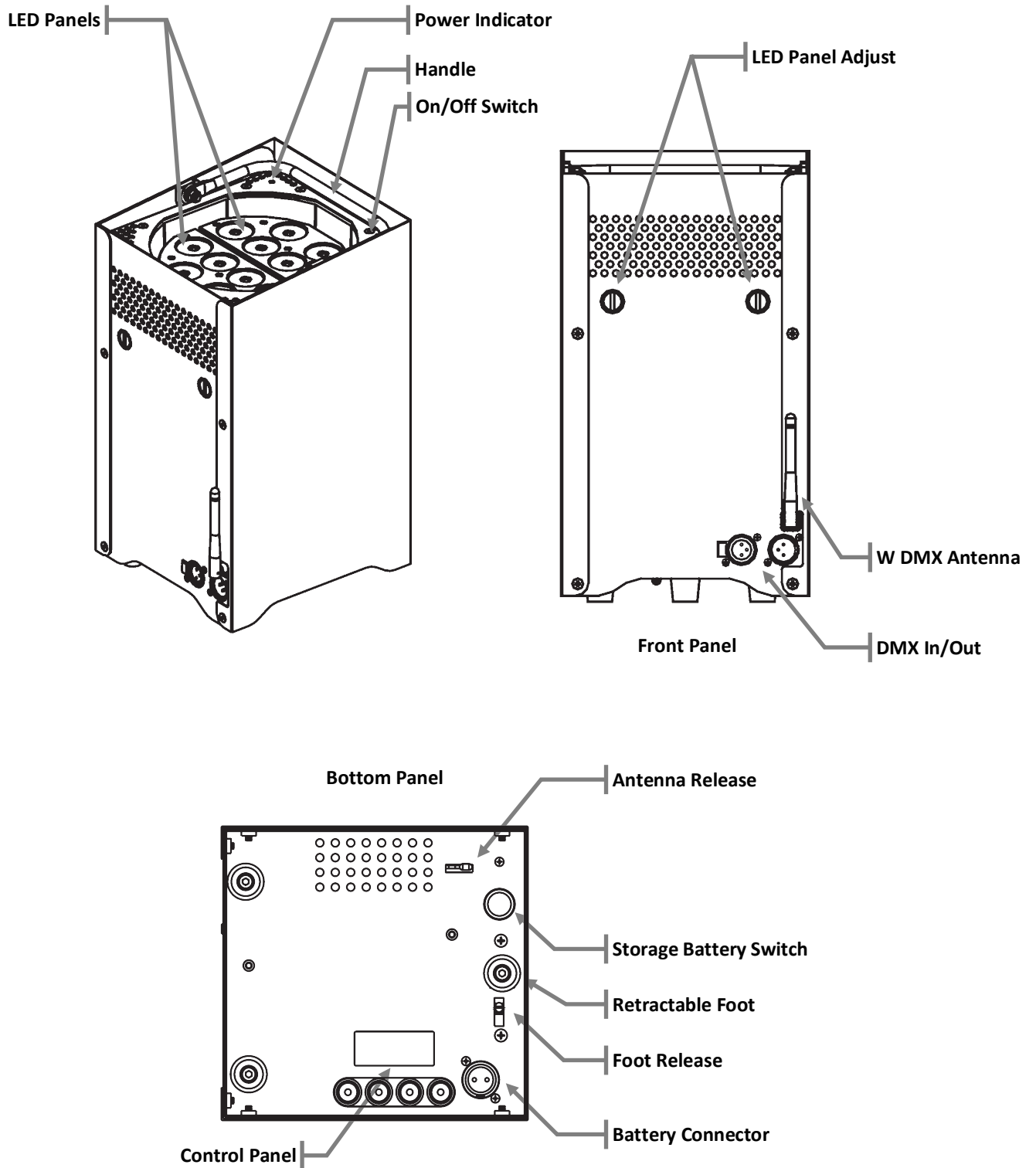

Product Dimensions

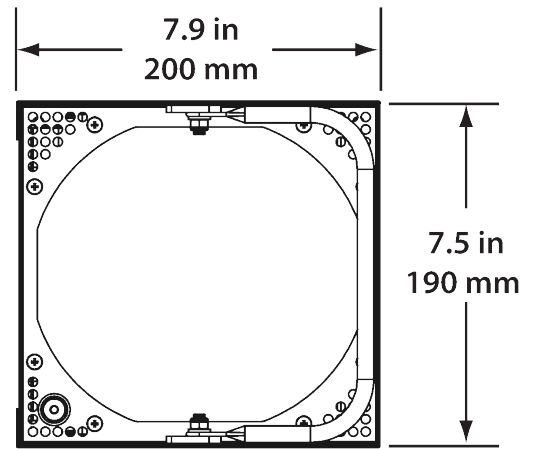
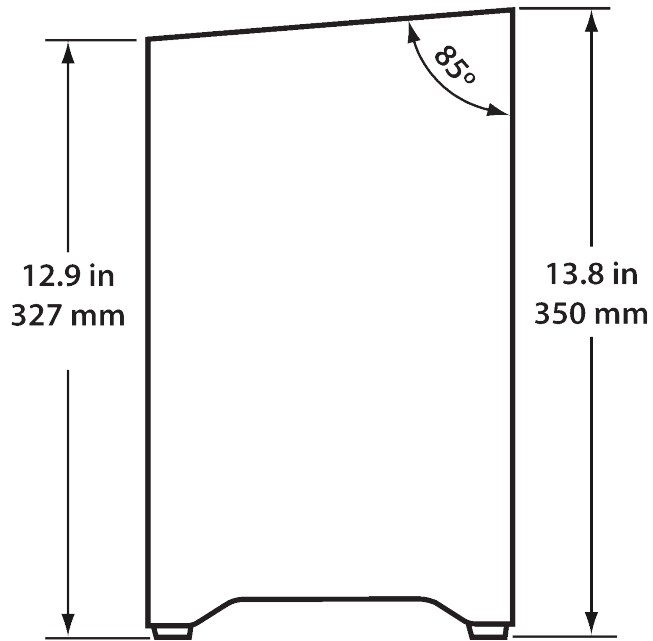

3. Setup

AC Power

The WELL's battery charger, whether stand-alone or inside the flight case, can work with an input voltage range of 100~240 VAC, 50/60 Hz.

Make sure that you are connecting this product to the proper voltage, as per the specifications in this guide, the product's user manual, or on the product's sticker.



Always connect this product's battery charger to a protected circuit with an appropriate electrical ground to avoid the risk of electrocution or fire.



Never connect this product's battery charger to a rheostat (variable resistor) or dimmer circuit, even if the rheostat or dimmer channel serves only as a 0 to 100% switch.

AC Plug

The WELL's battery charger comes with a power input cord terminated with an Edison plug (US market). If the power input cord that came with your product has no plug or you need to change the Edison plug, use the table below to wire the new plug.

Connection	Wire (US)	Wire (Europe)	Screw Color
AC Live	Black	Brown	Yellow or Brass
AC Neutral	White	Blue	Silver
AC Ground	Green/Yellow	Green/Yellow	Green



Make sure to disconnect the fixture's power cord before replacing a blown fuse, and always replace it with a fuse of the same type and rating.

Fuse

The stand-alone battery charger has no external fuse. However, the flight case/charger comes with a replaceable fuse (T 6.3 A @ 250 V).

To change the fuse on the flight case/charger, do the following:

- 1) Disconnect the fixture from the power outlet.
- 2) With a Phillips #2 head screwdriver, unscrew the fuse holder cap from its housing.
- 3) Remove the blown fuse and replace it with a good fuse of the same type and rating (F 3.15 A @ 250 V).
- 4) Screw the fuse holder cap back in its place and reconnect power.



DMX Linking

You may link the WELL to a DMX controller using a standard DMX serial connection. If using other DMX compatible fixtures with this product, it is possible to control them individually with a single DMX controller.

If you are not familiar with the DMX standard, or if you need information about the DMX cables needed to link the WELL to a DMX controller, you may download the "DMX Primer" document from the CHAUVET® Web site.

DMX Modes

The WELL uses the standard DMX data connection for its TOUR, ARC.1, AR1.D, AR1.S, HSV, and BLOC DMX modes. You will find information about these DMX modes in the *Introduction* chapter (DMX channel summary), the *Operation* chapter (configuration details), and the *DMX Values* section (individual channel values).

Master/Slave Connectivity

The Master/Slave mode allows a WELL unit to control one or more WELL units without a DMX controller. See the *Master/Slave* section of the *Operation* chapter for programming information. The master links to the slave fixtures using the standard DMX serial connection. If you are not familiar with the Master/Slave connectivity, you may download the “DMX Primer” document from the CHAUVET® Web site.



DO NOT connect a DMX controller to the fixtures operating in Master/Slave mode. Otherwise, the signals from the DMX controller may interfere with the signals from the master fixture.



The *Operation* chapter of this manual provides detailed instructions on how to configure the Master and Slave units.

Mounting

Before mounting this product, read and follow the safety recommendations indicated in the *Safety Notes* section (page 2 of this manual).

Orientation

Always mount this product in any safe position while making sure that there is adequate room around it for ventilation, configuration, and maintenance.

Rigging

CHAUVET® recommends following the general guidelines below when mounting this product.

- When selecting an installation location, consider ease of access to the fixture for operation, programming adjustments, and routine maintenance.
- Make sure to place this product away from any flammable material as indicated in the *Safety Notes* section.
- This unit's rating is IP 44. Therefore, do not mount the product in places where heavy rain, water jets, extreme temperature changes, or restricted ventilation may affect it.
- This is a floor-standing fixture. Do not hang this unit.

Procedure

- Make sure that you mount this product on a hard, steady surface that can support its weight.
- Do not tilt this product further than 10° or mount it on its side.

Correct Floor Mounting

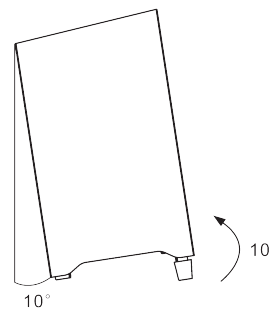

Product Mounting Diagram

Incorrect Floor mounting

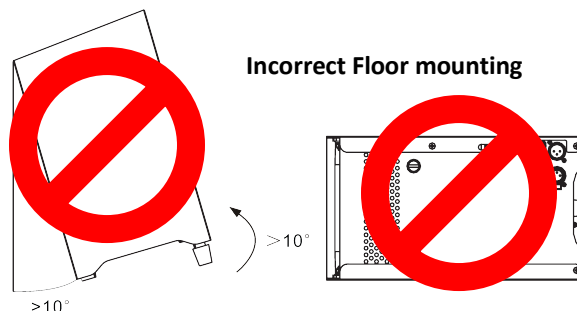

4. Operation

Operation Notes

- Always operate the unit in an upright position.
- Never tilt the unit more than 10°.
- Only use the retractable foot to tilt the unit.
- Do not operate the unit in a sealed enclosure or in an area without air circulation.

Turning Unit On

- Turn the battery storage switch on.
- Push the On/Off switch on the top for more than three seconds (the built-in red LED will illuminate solid).
- When not connected to the battery charger, the power status LED indicates the amount of remaining battery charge, as follows:
 - Green: >70 % (100~70% charge)
 - Yellow: >20 % (69~21 % charge)
 - Red: Empty (20~0 % charge)

Turning Unit Off

- Push the On/Off switch on the top for more than three seconds (the built-in red LED will turn off).
- If storing the unit for more than seven days after recharging it, also turn the battery storage switch off.

Tilt Angle

- Place the fixture on a flat, sturdy surface.
- Release the extensible foot by shifting the foot release lever.
- Keep the lever shifted to adjust the angle and release the lever.
- Do not allow the unit to tilt further than 10°.

LEDs Angle

- Use the screws on the unit's front panel to adjust the angle of the LED panels.
- The screw on the left adjusts the rear LED panel.
- The screw on the right adjusts the front LED panel.

Storage Notes

- Always store the unit in an upright position ($\leq 10^\circ$ tilt).
- Recharge the battery to full capacity before storing the unit.
- Store charged unit(s) in a dry environment, away from direct sunlight.
- Turn the battery storage switch off if storing the unit for more than seven days.

Battery Charge Notes

- Make sure to turn the battery storage switch on before connecting the unit to the charger.
- Always use the supplied charger to recharge the built-in battery.
- Recharge the battery within three days of last use.
- Recharge the battery to full capacity before storing this product.
- For best results, charge the battery in a temperature between 32° F (0° C) and 95° F (35° C).
- When charging the battery, keep the unit at no less than 1 m from any open flame or hot plate.
- When charging the battery inside the flight case/charger, keep the flight case's cover open.
- Always charge the battery with the unit in an upright position.
- Do not keep charging the battery for more than 24 hours.
- Perform a full discharge/recharge cycle every three months.
- During charging, the green power indicator LED will illuminate solid, regardless of the level of charge of the battery.
- Once fully charged, while still connected to the battery charger, the green power indicator LED will turn off.

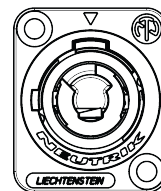
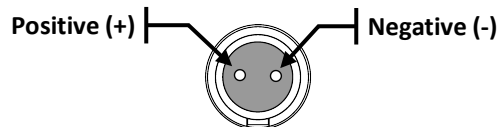
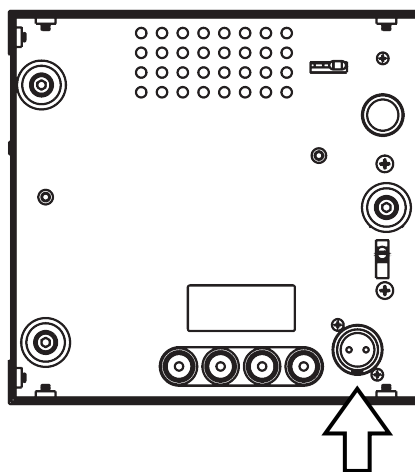

POWER IN



FUSE
T 6.3 A @ 250 V



Flight Case/Charger
Power Input Panel

Connection Warnings

- DO NOT plug a DMX cable to the battery connector or the stand-alone battery charger.
- DO NOT plug the stand-alone battery charger to a DMX connector.

Wireless Operation

The WELL can operate in W-DMX mode up to 300 m (900 feet) from the W-DMX transmitter. The W-DMX receiver in the WELL unit must be paired with the W-DMX transmitter for wireless operation.

Initial Setup

- 1) Turn the W-DMX transmitter on.
- 2) Connect the W-DMX transmitter to a DMX controller.
- 3) Place the WELL unit within 300 m from the W-DMX transmitter.
- 4) Disconnect any DMX cable from the WELL unit.
- 5) Push the antenna release to allow the W-DMX antenna to extend outside the metal housing.
- 6) Set the antenna in the upright position.
- 7) Turn the WELL unit on.

Configuration

- 1) From the WELL's control panel, go to **RUN > DMX**.
- 2) Select the start address, as with any other DMX compatible product.
- 3) Go to **WDMX > ACTI**.
- 4) Select **ON**.

Fixture Pairing

Fixture Already Paired

- 1) If the WELL unit has already been paired with the WDMX transmitter, the red LED on the On/Off switch will flash slowly.
- 2) In this case, the WELL unit is ready to work in wireless mode.

Pairing the WELL Unit and a new W-DMX Transmitter

- 1) From the WELL's control panel, go to **WDMX > REST**.
- 2) Select **YES** (the red LED on the On/Off switch will illuminate solid).
- 3) From the W-DMX transmitter, press **<RESET>** (the **SIGNAL** indicator will flash).
- 4) Once the transmitter has found the WELL fixture, the **SIGNAL** indicator on the W-DMX transmitter will illuminate solid.
- 5) The red LED on the On/Off switch will flash slowly indicating the presence of DMX signal.

WDMX Setup

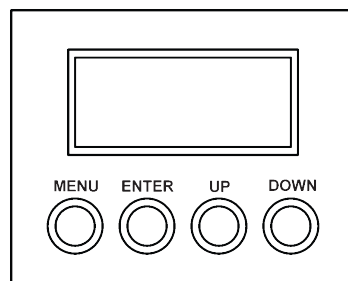

Control Panel

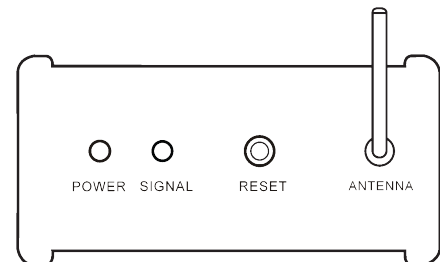

WDMX Transmitter

Control Panel Description

Button	Function
<MENU>	Exits from the current menu or function
<ENTER>	Enables the currently displayed menu or sets the currently selected value in to the current function
<UP>	Navigates upwards through the menu list and increases the numeric value when in a function
<DOWN>	Navigates downwards through the menu list and decreases the numeric value when in a function

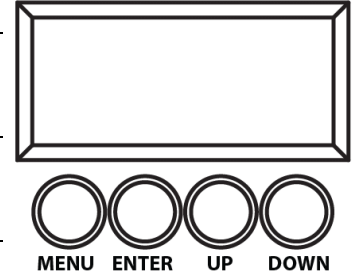

Control Options

You can set the WELL start address in the 001~512 DMX range. This allows for the control of up to 42 fixtures in the 12-channel TOUR personality.

Programming

Refer to the *Menu Map* on page 17 to learn how the menu options relate to each other. The menu map has a Menu Level and a variable number of programming levels for each option.

To go to an option in the Menu Level, press <MENU> repeatedly until the option shows on the display. Press <ENTER> to select it. This will take you to the first programming level for that option.

To select an option or value within the current programming level press <UP> or <DOWN> until it shows on the display. Press <ENTER> to accept it. In this case, if there is another programming level, you will see its first option. Otherwise, you will see the selected value.

To exit to the previous menu level, press <MENU>.

DMX Personality

This setting allows the user to choose a particular DMX personality.

- 1) Go to **PERS**.
- 2) Select the desired personality (**TOUR**, **ARC.1**, **AR1.D**, **AR1.S**, **HSV**, or **BLOC**).
- 3) See the *DMX Values* section for the highest starting address you can select for each personality.
- 4) Make sure that the starting addresses on the various fixtures do not overlap due to the new personality setting. See the *DMX Values* section.

DMX Control

In this mode, each unit will respond to a unique starting address from the DMX controller. All units with the same starting address will respond in unison.

- 1) Select a DMX personality, as shown in DMX Personality.
- 2) Set the running mode:
 - a) Go to **RUN**.
 - b) Select **DMX**.
- 3) Set the starting address:
 - a) Go to **ADDR**.
 - b) Select the starting address (**001~512**).

To ensure full access to all channels in each DMX mode, the highest recommended DMX addresses are as follows:

DMX Mode	DMX Address	DMX Mode	DMX Address	DMX Mode	DMX Address
TOUR	503	AR1.D	509	HSV	510
ARC1	510	AR1.S	508	BLOC	507

Continues on the next page

Continued from previous page

Static Color

The Static Color mode allows for permanent RGB color mixing without a DMX controller.

- 1) Go to **STAT**.
- 2) Select the desired color (**RED**, **GRN**, or **BLU**).
- 3) Select the desired color value (**0~255**).
- 4) Repeat for the other colors.
- 5) Select **STRB**.
- 6) Select the desired frequency (**0~20**).

Auto Programs

Auto programs allow for dynamic RGB color mixing without a DMX controller.

- 1) Go to **AUTO**.
- 2) Select the desired auto (**AT.01~10**) or custom program (**PR.01~10**).



You cannot edit any of the auto programs (AT.01~10). However, you can edit the custom programs (PR.01~10). See *Edit Customs* for details.

Edit Customs

This setting allows the programming of up to 30 scenes for each of the 10 customizable programs, including colors and effects.

- 1) Go to **EDIT**.
- 2) Select the desired auto program (**PR.01~10**).
- 3) Select the desired scene (**SC.01~30**).
- 4) Select the desired color or effect (**RED**, **GRN**, **BLU**, **STRB**, **TIME**, or **FADE**).
- 5) Select the color or effect value (**000~255** for colors and timers, or **00~20** for strobe).
- 6) Repeat for the other colors or effects.
- 7) Return to the **SCENE** level (step “3”).
- 8) Repeat the settings of colors and effects for the other scenes.

Master/Slave

The Master/Slave mode allows a group of WELL fixtures (the slaves) to simultaneously duplicate the output of another WELL (the master), whether static mode settings or auto/custom programs, without a DMX controller.

- 1) Set the master unit:
 - a) Set the running mode to **DMX** as explained in “*DMX Control*.”
 - b) Select an auto or custom program, as explained in “*Auto Programs*”, or a static mix of colors.
- 2) Set each of the slave units:
 - a) Go to **RUN**.
 - b) Select **SLAV**.



- **The fixture that is set to run a program, whether Auto or Custom, or to operate in Static mode automatically becomes the master.**
- **Do not connect a DMX controller to the master or slave fixtures.**
- **The master unit should be the first in the DMX string.**

Continues on the next page

Continued from previous page

Color Setting

The **COLOR** setting determines how the WELL generates the white color based on various RGB settings.

- 1) Go to **SET**.
- 2) Select **COLO**.
- 3) Select **OFF**, **RGBW**, or **UC**.

OFF: When the RGB faders are all set to “255”, the output is maximum, although the resulting white color may not be balanced.



RGBW: When the RGB faders are all set to “255”, the resulting output is defined by the configured White color (see *RGB to White Adjustment*).

UC: When the RGB faders are all set to “255”, the output matches that of less efficient fixtures (Universal Color).

Dimmer Curves

This setting determines how fast the output of the WELL changes when the operator modifies the values of the Red, Green, Blue, and Dimmer faders.

- 1) Go to **SET**.
- 2) Select **DIM**.
- 3) Select a dimmer curve (**OFF**, **DIM1**, **DIM2**, **DIM3**, or **DIM4**).

OFF: The output is proportional (linear) to the Dimmer and RGB channel values.



DIM1~4: The output follows the Dimmer and RGB channel values based on the corresponding dimmer curve, being **DIM1** the fastest and **DIM4** the slowest.

Control Panel Lock

This setting allows the user to activate or disable the control panel lock, which keeps non-authorized personnel from changing the fixture’s settings.

- 1) Go to **KEY**.
- 2) Select **ON** or **OFF**.



When the control panel lock is active, the fixture will prompt the user to enter the password after 30 seconds of control panel inactivity or after turning on the fixture.

After being prompted to enter the password:

Press **<UP>**, **<DOWN>**, **<UP>**, **<DOWN>**, and **<ENTER>**.

Color Macro Adjustment

This setting allows the user to select and edit the temperature of the white colors used in channel 8 (Macros) when in the TOUR mode.

- 1) Go to **CAL1**.
- 2) Select a white color (**WH.01~11**).
- 3) Select a color (**RED**, **GREN**, or **BLUE**).
- 4) Select a color value (**0~255**).
- 5) Repeat for the other colors.

Continues on the next page

Continued from previous page

RGB to White Adjustment

This setting allows the user to select and edit the temperature of the white color shown when RGB to White (**RGBW**) is active in **SET > COLO** (see *Color Setting*).

- 1) Go to **CAL2** and
- 2) Press **<ENTER>** when you see **RGB.W** on the display.
- 3) Select a color (**RED, GREEN, or BLUE**).
- 4) Select a color value (**0~255**).
- 5) Repeat for the other colors.



The values of **RED, GREEN, and BLUE** configured from **RGB.W** will define the color temperature shown when the RGB faders are set to “255” if **SET > COLO > RGBW** is active.

Battery Life

This setting allows the user to select the output intensity for a given runtime (battery life).

- 1) Go to **SET**.
- 2) Select **LIFE**.
- 3) Select a battery life (**NORM or LONG**).



When the LIFE parameter is set to NORM, the battery life is approx. 10 hours. When the LIFE parameter is set to LONG, the battery life extends to approx. 12 hours.

Program Upload

This option allows the user to copy the custom programs of one WELL fixture onto other WELL fixtures by using the Master/Slave method.

- 1) Configure and connect the fixtures in a Master/Slave arrangement, where the master unit has the custom programs you want to transfer onto the slave units.
- 2) At the master unit, go to **SET**.
- 3) Select **UPLD**.
- 4) When **PASS** shows, press **<ENTER>**.
- 5) Enter the master access password as shown in *Control Panel Lock*.
- 6) When **SEND** shows, press **<ENTER>** to start the upload.
- 7) Wait for the upload process to finish (the display will show **END**) before continuing or turning the fixtures off.

During and after the upload, the master and slave units will visually indicate the status of the process, as follows:



- **Yellow means that the upload is running.**
- **Red means that the upload failed due to an error.**
- **Green means that the upload completed successfully.**



DO NOT upload the program from a WELL onto a different fixture. Otherwise, you could render the other fixture inoperative.

Continues on the next page

Continued from previous page

- Reset** This setting allows the user to reset the WELL fixture to its default values, including deleting the custom programs.
- 1) Go to **SET**.
 - 2) Select **REST**.
 - 3) When prompted, enter the master access password as shown in *Control Panel Lock*.
 - 4) Wait for the reset process to finish.

Default Values

Parameter	Default Value	Parameter	Default Value
STAT	R/G/B.000	LIFE	NORM
AUTO	AT.01	EDIT	PR.01/SC.01
ADDR	D.001	CAL1	WH.01
RUN	DMX	RGB.W	R/G/B.255
PERS	TOUR	WDMX	ACTI
DIM	DIM4	KEY	OFF
COLO	UC		

TOUR Notes

These notes intent to clarify the way the TOUR DMX personality works.

Master Dimmer

- Channel 1 (Dimmer) controls the intensity of the currently projected color.
- When the slider is at the highest position (**255**) the intensity of the output is at its maximum.

Red, Green, and Blue Color Selection

- Channels 2 though 7 control the intensity ratio of each of the Red, Green, and Blue colors on each LED panel.
- When these six sliders are at their highest setting (**255**), the intensity of each color is at its maximum if **SET > COLO** is **OFF**.

Color Macros

- Channel 8 (Macros) selects the required color macro.
- Channel 8 has priority over channels 2 through 7.
- Channel 1 (Dimmer) controls the intensity of the selected color macro.

Strobe

- Channel 9 controls the strobe frequency (not the intensity) of channels 2 through 7.
- Channel 9 can strobe channels 2 through 7 when the WELL is not running macros (channel 8 inactive), thus allowing the individual color faders as well as channel 1 (Dimmer) to control the output intensity.
- Channel 9 can strobe channel 8 when the WELL is running macros (channel 8 active), allowing channel 8 to select the macro and channel 1 to control the output intensity.

Auto/Custom

- Channel 10 (Auto/Custom) selects the preset auto programs **AT.01~10** or the custom programs **PR.01~10**.
- Channel 10 has priority over channels 2 through 9.
- Channel 11 determines the speed at which each auto program (**AT.01~10**) plays.

Dimmer Speed

- Channel 12 selects the dimmer mode and speed. When **DIM** is set to **OFF**, the changes in the RGB and Dimmer faders are linear. Otherwise, **DIM1** is the fastest dimmer curve, while **DIM4** is the slowest.

Menu Map

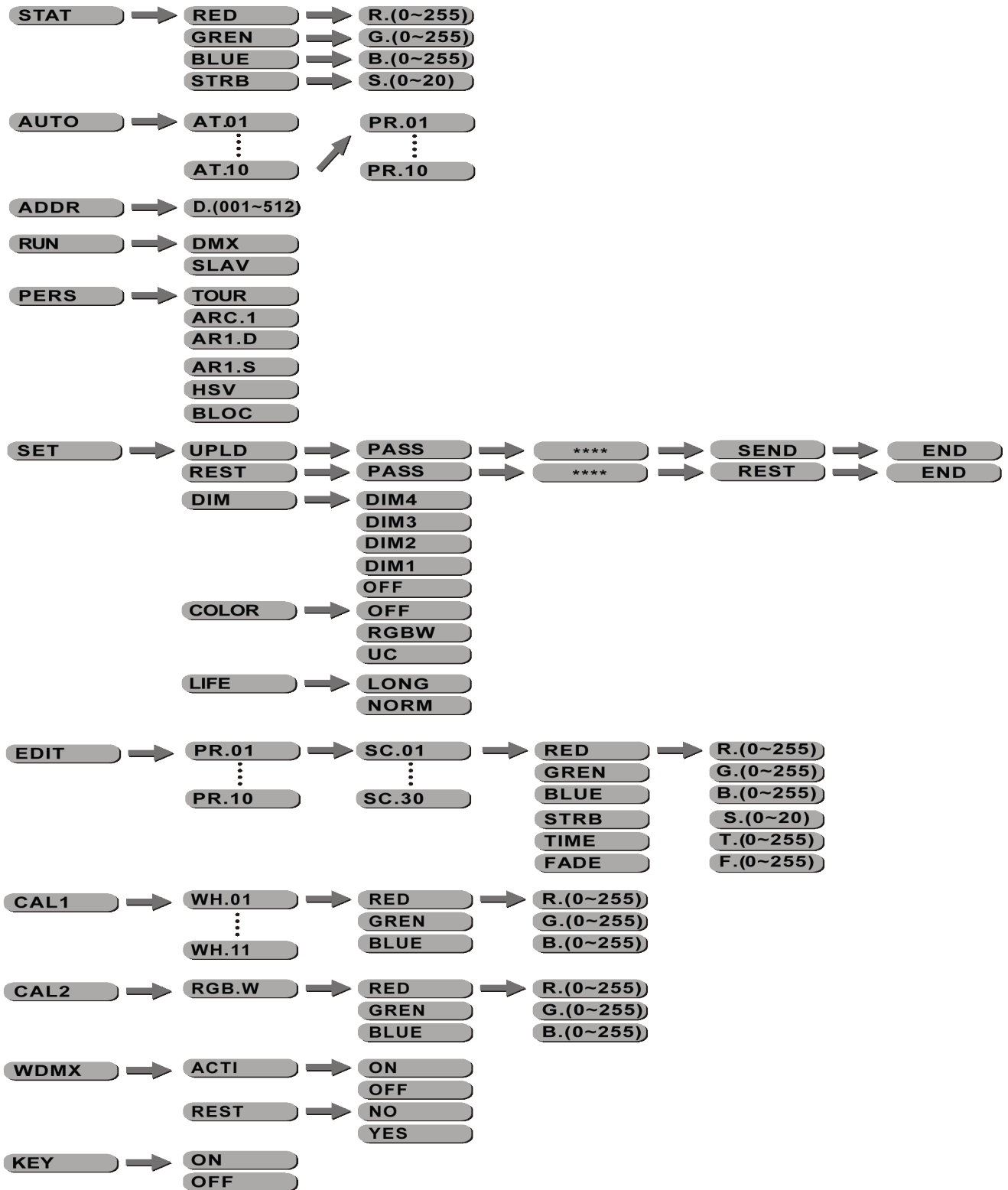

Operation

DMX Values

TOUR

Channel	Function	Value	Percent/Setting
1	Master Dimmer	000 ó 255	0~100%
2	Module 1 Red	000 ó 255	0~100%
3	Module 1 Green	000 ó 255	0~100%
4	Module 1 Blue	000 ó 255	0~100%
5	Module 2 Red	000 ó 255	0~100%
6	Module 2 Green	000 ó 255	0~100%
7	Module 2 Blue	000 ó 255	0~100%
8	Color Macro + White Balance	000 ó 010	No function
		011 ó 030	R: 100% G: Up B: 0%
		031 ó 050	R: Down G: 100% B: 0%
		051 ó 070	R: 0% G: 100% B: Up
		071 ó 090	R: 0% G: Down B: 100%
		091 ó 110	R: Up G: 0% B: 100%
		111 ó 130	R: 100% G: 0% B: Down
		131 ó 150	R: 100% G: Up B: Up
		151 ó 170	R: Down G: Down B: 100%
		171 ó 200	R: 100% G: 100% B: 100% W: 100%
		201 ó 205	White 1: 3200 K
		206 ó 210	White 2: 3400 K
		211 ó 215	White 3: 4200 K
		216 ó 220	White 4: 4900 K
		221 ó 225	White 5: 5600 K
		226 ó 230	White 6: 5900 K
231 ó 235	White 7: 6500 K		
236 ó 240	White 8: 7200 K		
241 ó 245	White 9: 8000 K		
246 ó 250	White 10: 8500 K		
251 ó 255	White 11: 10,000 K		
9	Strobe	000 ó 010	No Function
		011 ó 255	1~20 Hz
10	Auto + Custom Programs	000 ó 040	No function
		041 ó 050	Auto 1
		051 ó 060	Auto 2
		061 ó 070	Auto 3
		071 ó 080	Auto 4
		081 ó 090	Auto 5
		091 ó 100	Auto 6
		101 ó 110	Auto 7
		111 ó 120	Auto 8
		121 ó 130	Auto 9
		131 ó 140	Auto 10
		141 ó 150	Custom 1
		151 ó 160	Custom 2
		161 ó 170	Custom 3
		171 ó 180	Custom 4
		181 ó 190	Custom 5
191 ó 200	Custom 6		
201 ó 210	Custom 7		
211 ó 220	Custom 8		
221 ó 230	Custom 9		
231 ó 255	Custom 10		
11	Auto Speed	000 ó 255	0~100% (only if AT.01~10 is playing)
12	Dimmer Speed	000 ó 009	Preset dimmer speed from display menu
		010 ó 029	Linear dimmer
		030 ó 069	Nonlinear dimming curve 1 (fastest)
		070 ó 129	Nonlinear dimming curve 2
		130 ó 189	Nonlinear dimming curve 3
190 ó 255	Nonlinear dimming curve 4 (slowest)		

ARC.1	Channel	Function	Value	Percent/Setting
	1	Red	000 ó 255	0~100%
	2	Green	000 ó 255	0~100%
	3	Blue	000 ó 255	0~100%

AR1.D	Channel	Function	Value	Percent/Setting
	1	Master Dimmer	000 ó 255	0~100%
	2	Red	000 ó 255	0~100%
	3	Green	000 ó 255	0~100%
	4	Blue	000 ó 255	0~100%

AR1.S	Channel	Function	Value	Percent/Setting
	1	Master Dimmer	000 ó 255	0~100%
	2	Red	000 ó 255	0~100%
	3	Green	000 ó 255	0~100%
	4	Blue	000 ó 255	0~100%
	5	Strobe	000 ó 010 011 ó 255	No Function 1~20 Hz

HSV	Channel	Function	Value	Percent/Setting
	1	Hue	000 ó 255	0~100%
	2	Saturation	000 ó 255	0~100%
	3	Value	000 ó 255	0~100%

BLOC	Channel	Function	Value	Percent/Setting
	1	Module 1 Red	000 ó 255	0~100%
	2	Module 1 Green	000 ó 255	0~100%
	3	Module 1 Blue	000 ó 255	0~100%
	4	Module 2 Red	000 ó 255	0~100%
	5	Module 2 Green	000 ó 255	0~100%
	6	Module 2 Blue	000 ó 255	0~100%

5. Technical Information

Fixture Maintenance

To maintain optimum performance and minimize wear, the user should clean this product frequently. Usage and environment are contributing factors in determining the cleaning frequency.

As a rule, the user should clean this product at least twice a month. Dust build up reduces light output performance and can cause overheating. This can lead to reduced light source life and increased mechanical wear.

To clean a fixture, follow the recommendations below:

- Unplug the fixture from power.
- Wait until the fixture is cold.
- Use a vacuum (or dry compressed air) and a soft brush to remove dust collected on the external vents and accessible components.
- Clean the LED lens cover with a mild solution of non-ammonia glass cleaner or isopropyl alcohol.
- Apply the solution directly to a soft, lint-free cotton cloth or a lens cleaning tissue.
- Drag any dirt or grime to the outside of the LED lens cover.
- Gently polish the LED lens cover until it is free of haze and lint.



Always dry the LED lens cover carefully after cleaning it to prevent stains and discoloration.

Troubleshooting Guide

Symptom	Cause(s)	Action(s)
Low output	Depleted battery Incorrect COLOR settings Dirty LED lens cover LED panels in wrong angle	Recharge battery Check COLO, CAL1, and CAL2 settings Clean LED lens cover Reorient LED panels
One or more LEDs on a panel do not illuminate	Faulty LED(s) No power to the LEDs Faulty main control board	Send unit for repair
No LED illuminates Control panel operates normally	No power to the LEDs Faulty main control board Faulty internal wiring	Send unit for repair Send unit for repair Check wiring
Circuit breaker/fuse keeps tripping/blowing	Excessive circuit load Short circuit along the power wires	Reduce total load placed on the electrical circuit Check for a short in the electrical wiring
Fixture does not power up	Depleted battery Internal fuse blown Faulty power converters Faulty main control board	Recharge battery Call CHAUVET® technical support Send unit for repair Send unit for repair
Battery does not charge	Battery switch off on WELL No power to battery charger Blown fuse on flight case charger Faulty external battery charger Faulty flight case charger Faulty battery	Turn battery switch on Check for voltage on outlet Replace fuse (T 6.3 A @ 250 V) Replace external battery charger Send flight case for repair Replace battery
Fixture does not respond to wired DMX or responds erratically	Wrong DMX addressing Loose DMX cables Damaged DMX cables Wrong polarity on the controller Non DMX cables Bouncing signals Low level signal / long cable Too many fixtures Interference from AC wires Faulty DMX interface Faulty main control board	Check unit addressing Check cable connections Check DMX cables Check polarity switch settings on the controller Use only DMX compatible cables Install terminator as suggested Install an optically coupled DMX splitter right after the fixture with the strong signal or before a long section of cable Install an optically coupled DMX splitter after unit #32 Keep DMX cables separated from power cables or fluorescent/black lights Send unit for repair Send unit for repair
Fixture does not respond to wireless DMX	W-DMX deactivated WELL antenna not deployed WDMX transmitter off WELL and transmitter not paired WELL beyond transmitter's range Interference from other equipment	Activate W-DMX from the Control Panel Extend the W-DMX antenna Turn WDMX transmitter on Pair the WELL to the W-DMX transmitter Move the W-DMX transmitter closer to the WELL Reposition the WELL for better reception



If you still experience technical problems after trying the above solutions, contact CHAUVET® Technical Support.

Returns Procedure

The user must send the merchandise prepaid, in the original box, and with its original packing and accessories. CHAUVET® will not issue call tags.

Call CHAUVET® and request a Return Merchandise Authorization (RMA) number before shipping the fixture. Be prepared to provide the model number, serial number, and a brief description of the cause for the return.

The user must clearly label the package with a Return Merchandise Authorization (RMA) number. CHAUVET® will refuse any product returned without an RMA number.



DO NOT write the RMA number directly on the box. Instead, write it on a properly affixed label.

Once you have received the RMA number please include the following information on a piece of paper inside the box:

- Your name
- Your address
- Your phone number
- The RMA number
- A brief description of the problem

Be sure to pack the fixture properly. Any shipping damage resulting from inadequate packaging will be the customer's responsibility. As a suggestion, proper UPS packing or double-boxing is always a safe method to use.



CHAUVET® reserves the right to use its own discretion to repair or replace returned product(s).

Claims

The carrier is responsible for any damage incurred during shipping to this product or any part that shipped with it. Therefore, if the received merchandise appears to have damages caused during shipping, the customer must submit the damage report and any related claims with the carrier, not CHAUVET®. The customer must submit the report upon reception of the damaged merchandise. Failure to do so in a timely manner may invalidate the customer's claim with the carrier.

For other issues such as missing components or parts, damage not related to shipping, or concealed damage, the customer must make claims to CHAUVET® within seven (7) days of receiving the merchandise.

Contact Us

World Headquarters

CHAUVET®

General Information

Address: 5200 NW 108th Avenue
Sunrise, FL 33351
Voice: (954) 929-1115
Fax: (954) 929-5560
Toll free: (800) 762-1084

Technical Support

Voice: (954) 929-1115 (Press 4)
Fax: (954) 756-8015

World Wide Web

www.chauvetlighting.com

United Kingdom & Ireland

CHAUVET® Europe Ltd.

General Information

Address: Unit 1C
Brookhill Road Industrial Estate
Pinxton, Nottingham, UK
NG16 6NT
Voice: +44 (0)1773 511115
Fax: +44 (0)1773 511110
Email: uktech@chauvetlighting.com

World Wide Web

www.chauvetlighting.co.uk

Technical Specifications

Dimensions and Weight	Length	Width	Height	Weight
	7.0 in (200 mm)	7.5 in (190 mm)	13.8 in (350 mm)	36.3 lbs (16.5 kg)

Note: Dimensions in inches rounded to the nearest decimal digit.

Electrical	Power Supply Type	Range	Voltage Selection
	Battery charger (external)	100~240 V, 50/60 Hz	Auto-ranging

Battery Type	Battery Voltage/Capacity	Power Consumption
Lead acid gel	12 V / 24 Ah	45 W

Light Source	Type	Power	Lifespan
	LED	3 W	50,000 hours

Configuration	Quantity	Current
Tricolor (RGB)	12	3 x 350 mA

Photo Optic	Parameter	Standard 16° Optics
	Illuminance @ 5 m	225 lx
	Beam angle	17°
	Field angle	32°

Thermal	Maximum External Temp.	Cooling System	IP Rating
	104° F (40° C)	Convection	IP44

DMX	I/O Connectors	Connector Type	Channel Range
	3-pin XLR	Sockets	3, 4, 5, 6, 12

WDMX	DMX Channels	Range	Frequency
	512	300 m	2.4 GHz

Ordering	WELL (single unit)	WELL (Six-unit set)	W-DMX Transmitter
	01030296	01030299	01080295

Options	WELL Stand-alone Battery Charger	WELL Six-bay Flight Case/Charger (empty)
	01110298	01110297

CHAUVET®

5200 NW 108th Avenue
Sunrise, FL 33351 (USA)
(800) 762-1084 – (954) 929-1115
FAX (954) 929-5560
www.chauvetlighting.com

WELL User Manual Rev. 01e
May 2011



CHAUVET®
PROFESSIONAL

It's Green Thinking