

NORTRON by **BROAN**

INSTALLATION AND USER MANUAL

B SERIES ELECTRIC FURNACE

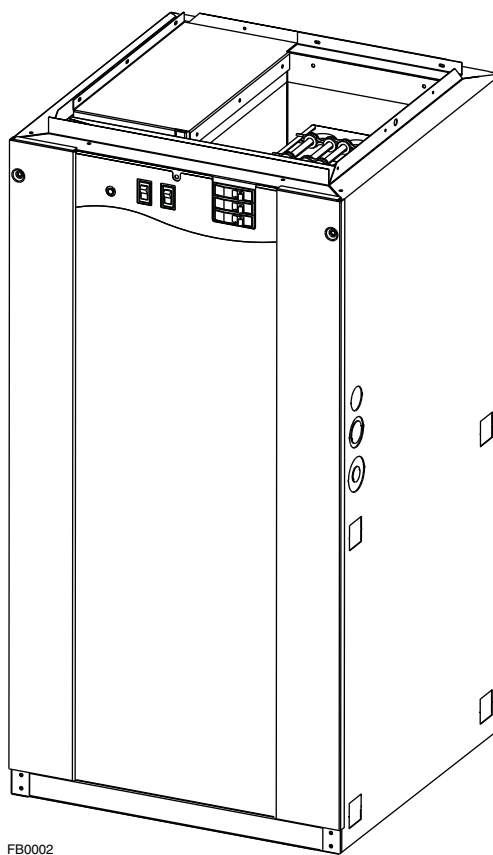

MODELS: 21B10M, 21B15M, 21B18M, 21B20M, 21B25M, 21B27M, 83B13, 83B24 AND 83B27

IMPORTANT: READ AND SAVE THESE INSTRUCTIONS.

Broan-NuTone Canada Inc.; Mississauga, Ontario www.broan.ca 877-896-1119

30042478B

⚠ WARNING

- Never tamper with the unit or its controls. User **MUST** contact a specialized contractor when a failure occurs. **DO NOT ATTEMPT** to repair.
- When using a humidifier make sure not to damage the heating element bank.
- We recommend that your unit be inspected by a specialized technician once a year.
- Poor maintenance of air filters OR an unbalanced static pressure may result in a performance decrease.
- Always use genuine parts for maintenance or service call. The use of unbranded parts will void the warranty.
- The use of this unit without an air distribution duct will void the warranty.
- It is strictly forbidden to use jumpers to simulate heat demand.
- Risk of electrical shock. Disconnect power before installation, servicing, maintenance or field wiring. Replace all panels before operating. Failure to do so can result in electrical shock causing severe injuries or death.
- When performing installation, servicing or cleaning the unit, it is recommended to wear safety glasses and gloves.
- To assure a proper performance of your furnace, we recommend that you use high quality name brand thermostats.
- When applicable local regulation comprises more restrictive installation and/or certification requirements, the aforementioned requirements prevail on those of this document and the installer agrees to conform to these at his own expenses.
- For your safety, do not store or use gasoline or other flammable liquids and vapors in the vicinity of this unit or any other appliance.
- These instructions are intended to be used by qualified personnel who have been trained in installing this type of furnace. Installation of this furnace by an unqualified person may lead to equipment damage and/or hazardous condition which may lead to bodily harm.
- This furnace is not watertight and is not designed for outdoor installation. This furnace shall be installed in such a manner as to protect its electrical components from water. Outdoor installation leads to a hazardous electrical condition and to premature furnace failure, thus voiding the warranty.
- Do not block the combustion air openings in the furnace. Any blockage will result in improper overheat situation and may result in a fire hazard and/or cause bodily harm.
- The unit must have an uninterrupted or unbroken electrical ground to minimize personal injury if an electrical fault should occur. When performing electrical connection, the ground conductor must be firmly attached to the ground lug in the furnace.
- Do not use this furnace as a construction heater. Use of this furnace as a construction heater exposes the furnace to abnormal conditions, contaminated combustion air and the lack of air filters. Failure to follow this warning can lead to premature furnace failure and/or vent failure which could result in a fire hazard and/or bodily harm.
- The owner and/or the user is responsible of the following: Always maintain the immediate surrounding of the furnace free from combustible and highly flammables materials. The furnace ambient air should not have an excessive dust concentration and humidity. Never operate this central heating appliance without an air filter.
- Before performing any service functions, unless operations specifically require the power to be on, make sure all utilities are turned "OFF" upstream of the appliance. Failure to comply with this warning will cause a fire hazard and/or bodily harm.
- All questions regarding the operation, maintenance or warranty of this unit should be addressed to the company where this product has been sold from.

CAUTION

- Never burn garbage or paper in the heating system and never leave rags or paper around the unit.
- Return air grilles and warm air registers must not be obstructed.

IMPORTANT: All local and national code requirements governing the electrical installation heating equipment, wiring and flue connections must be followed. Some of the codes that may be applicable are :

ANSI/NFPA 70 NATIONAL ELECTRICAL CODE

CSA C22.1 CANADIAN ELECTRICAL CODE

Only the latest issues of the above codes should be used, and are available from either:

The National Fire Protection Agency
Batterymarch Park
Quincy, MA 02269

or

The Canadian Standards Association
178 Rexdale Blvd.
Rexdale, Ontario M9W 1R3

TABLE OF CONTENTS

1. DIMENSIONS	3
2. GENERAL REQUIREMENTS AND SPECIFICATIONS	4
3. OPERATING OPTIONS	5
4. BREAKERS	5
5. INSTALLATION NOTES	6
5.1 COLD AIR RETURN	6
5.2 ELECTRICAL WIRING - POWER SUPPLY	6
5.3 CONNECTING AND ADJUSTING THE LOW VOLTAGE THERMOSTAT	6
6. USE IN MOBILE HOMES	6
7. USING OPTIONAL EQUIPMENT	7
7.1 TWO-STAGE OR OUTDOOR THERMOSTAT	7
7.2 AIR CONDITIONING	7
7.3 ELECTRONIC AIR CLEANERS AND/OR POWERED FURNACE HUMIDIFIERS	7
7.4 INTERLOCK CONNECTION	7
8. WIRING DIAGRAMS	8-11
9. SERVICE PARTS	12
10. MAINTENANCE	13
11. TROUBLESHOOTING	13
12. WARRANTY	14

1. DIMENSIONS

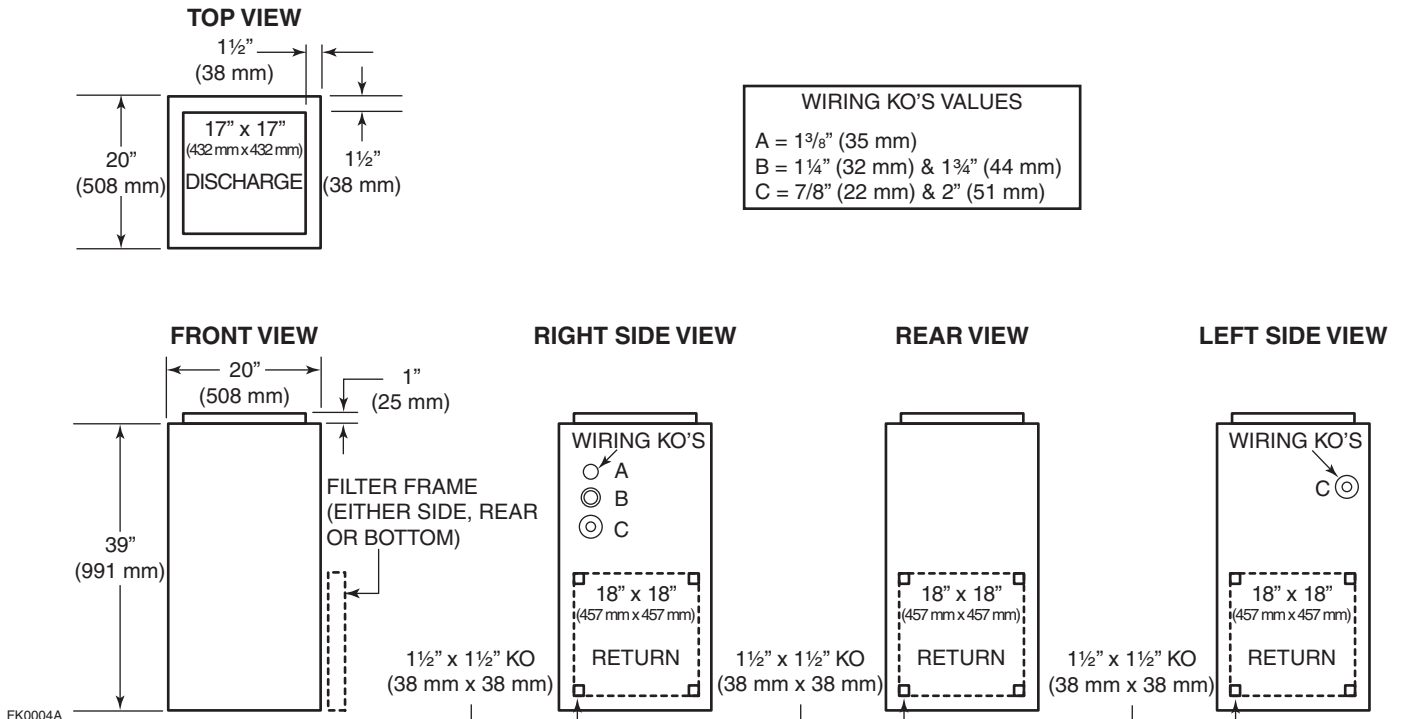

2. GENERAL REQUIREMENTS AND SPECIFICATIONS

CAUTION

This unit must be installed in a dry place, in a non-corrosive, well-ventilated environment, without excessive dust. The ambient temperature must be over 10°C and under 27°C. If the ambient temperature is 10°C or less, the plenum must be insulated on 10 ft linear minimum length.

1. LOCATION - The furnace should be centrally located to the heating area.
2. POSITIONS - It can be installed for vertical, horizontal or downflow operation. When installed horizontally, the furnace should be positioned such as the door will not end up being on the top. The door should be on the side of the furnace, to ensure that the motor bearings are in their designed position. In vertical downflow installations, use only "L"- or "T"-shaped plenum with no openings or registers directly below furnace.
3. INSTALLATION CLEARANCES - As shipped from the factory, each unit is approved for "zero inch" clearance. If additional clearance is required, it will be indicated on the data label attached to the furnace.
4. TEMPERATURE RISE - Furnaces are shipped to operate at 0.20" W.C. (50 Pa) external static pressure. They are certified for operation up to 0.50" W.C. (125 Pa). Check below for temperature rise table on specification chart and, if necessary, adjust the unit to match.
5. SERVICE CLEARANCE - Units are serviced from the FRONT. Leave at least 24" (610 mm) clearance in front of the door.

240 VOLTS - SINGLE PHASE						TEMPERATURE RISE @ 0.20" W. C.			
MODEL NO.	KW	BTHU	AMPS INCL. MOTOR	HP	BLOWER	°C	°F	*SPEED	RPM
21B10M	10	34152	46	1/3	10" x 8" (254 mm x 203 mm)	23	41	LOW	663
21B15M	15	51228	67	1/3		24	43	MED-LOW	814
21B18M**	18	61473	77	1/3		27	49	MED-LOW	814
21B20M**	20	68304	86	1/3		33	59	MED-LOW	814
21B25M**	25	85379	107	1/3		37	67	MED-LOW	814
21B27MS****†	27	92210	116	3/4	12" x 8" (304 mm x 203 mm)	36	65	MED-HIGH	707
208 VOLTS - THREE-PHASE									
83B13	13.5	46105	42	1/3	10" x 8" (254 mm x 203 mm)	21	38	MED	960
83B24	24	81964	70	1/3		35	63	MED	960
83B27	27	92210	78	1/3		39	70	MED	960

10" x 8" (254 mm x 203 mm) BLOWER							
SPEED	FLOW RATE	STATIC PRESSURE (INCHES OF WATER COLUMN)					
		0.2	0.3	0.4	0.5	0.6	
LOW	CFM	756	749	740	729	713	
	L/s	357	353	349	344	337	
MED-LOW	CFM	1035	1018	997	971	935	
	L/s	488	480	470	458	441	
MED-HIGH	CFM	1177	1157	1132	1102	1063	
	L/s	556	546	534	520	502	
HIGH	CFM	1301	1276	1247	1207	1145	
	L/s	614	602	588	569	540	

12" x 8" (304 mm x 203 mm) BLOWER							
SPEED	FLOW RATE	STATIC PRESSURE (INCHES OF WATER COLUMN)					
		0.2	0.3	0.4	0.5	0.6	
LOW****	CFM	727	699	667	636	606	
	L/s	343	330	315	300	286	
MED-LOW****	CFM	912	897	878	853	823	
	L/s	431	423	414	402	388	
MED-HIGH	CFM	1216	1200	1181	1157	1129	
	L/s	574	566	557	546	533	
HIGH	CFM	1640	1601	1558	1513	1466	
	L/s	774	755	735	714	692	

WARNING:

*FACTORY SETTINGS.

** 21B18M, 21B20M and 21B25M must NOT be setup to run continuously at LOW speed as it will cause overheating conditions. These models are certified to run only at HIGH, MED-HIGH and MED-LOW speeds.

*** 21B27MS must NOT be setup to run continuously at LOW or MED-LOW speeds, as it will cause overheating conditions. This model is certified to run only at HIGH and MED-HIGH speeds.

****These speeds can only be run with heater off, for cooling/ventilation purposes only.

†21B27MS has built-in additional noise-absorption components to run quietly during continuous or regular cycle modes.

SPECIFICATIONS SUBJECT TO CHANGE WITHOUT NOTICE

3. OPERATING OPTIONS

The furnace is shipped from the factory in a "Standard Heating Mode" (all switches are in the Down position). When the thermostat calls for heat, the automatic controls will be activated and the furnace turned "ON".

The blower will run at low speed as the furnace heats up and will automatically switch to the pre-programmed heating speed when additional elements are activated by the time delay relays.

The timing of this blower speed change will depend on the size of the furnace (10 kW and 13.5 kW models do not change speed), and whether **Cold** or **MILD** is selected on the **SEASON SELECT** switch.

You may, however, change from the Standard Heating Mode by using the controls built into your furnace.

CONTINUOUS VENTILATION



- ON** – Some homeowners prefer the blower to run at low speed to more evenly distribute air in the house. In this position, the blower will run continuously on low and automatically change to the necessary heating speed when heating elements are turned on by the thermostat.
- OFF** – The blower motor will operate in the standard heating mode, controlled by the thermostat.

SEASON SELECT



MILD
(NOT INCLUDED IN MODELS
21B10M AND 83B13)
COLD

- MILD** – During spring and fall, you may not require full heating capacity to maintain a comfortable temperature. In this position, approximately half of the elements are "off-line" and will not be energized when the thermostat calls for heat.
 - COLD** – All elements are "on-line" and controlled by the thermostat.
- NOTE:** If outdoor or two-stage thermostat is used, switch **MUST** be in **MILD** position at all times.

4. BREAKERS

B Series furnaces are equipped with breakers, located on the front panel of the unit. These devices protect the heating elements from overcurrent. If this situation occurs, the breakers will open to cut the power from the heating elements only.

NOTE: The number of breakers varies according to the furnace model; 21B10M model has no breakers, 21B15M, 21B18M, 21B20M and 83B13 models have 2 breakers and 21B25M, 21B27M, 83B24 and 83B27 models have 3 breakers. Refer to Section 8 Wiring Diagrams.

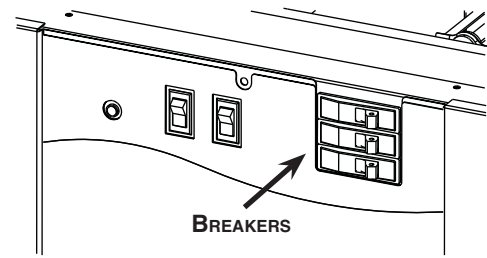

FD0001

⚠ WARNING

Breakers do not cut power to entire furnace, only to the heating elements. Do not use the breakers to turn off the furnace. The power to the whole unit can only be cut from the main electrical panel.

5. INSTALLATION NOTES

5.1 COLD AIR RETURN

The duct can be attached to either side, rear or the bottom of the furnace.

For side return there are four 1½" (38 mm) knockouts which can be removed and used as an outline for cutting a 18" x 18" (457 mm x 457 mm) return air opening in the furnace left or right side. Mount the filter frame to the furnace over the opening with the open side of the frame facing front. Then attach the 19" x 19" (483 mm x 483 mm) air duct to the flanges on the filter frame.

For bottom mounting, remove the screws holding the bottom plate to the furnace, discard the bottom plate and attach the filter frame to the bottom flanges with the open side of the frame facing front.

5.2 ELECTRICAL WIRING - POWER SUPPLY

The furnaces are completely factory wired. From a separate breaker, a two-wire plus ground supply wire is required for single phase units, and a three-wire plus ground supply wire for three phase units. The ground conductor must be firmly attached to the ground lug in the furnace and the supply wires to the terminal block in the furnace.

NOTE: On single-phase furnaces, when a FK120 kit is used to supply an air cleaner and/or humidifier, a third (neutral) conductor must be brought into the furnace.

⚠ WARNING

For all installations, we only recommend appropriate gauge good quality copper wire(s). However, it is the electrician's responsibility to ensure that the wiring and connections are compliant to the latest editions of the Canadian Electrical Code and local codes.

5.3 CONNECTING AND ADJUSTING THE LOW VOLTAGE THERMOSTAT (Use only class 1 wires inside furnace compartments.)

Attach thermostat wires to the low voltage terminal block located on the inside of the furnace. Follow the diagrams supplied with the thermostat. As a general guide, remember that the R & W terminals control single stage heating; the R & Y terminals control cooling. Single stage cooling uses "Y/Y2" as first and only stage. Two-stage cooling uses "Y1" as first stage and "Y/Y2" as second stage. Make sure the thermostat is levelled on the wall and in appropriate location as per instructions supplied with the thermostat.

CAUTION

Before turning the furnace on, the heat anticipator in the thermostat must be properly set.

Because each installation is different an accurate reading of the current draw should be made with an AC meter. Set the meter at 2 A range for furnaces through 20 kW, and at 4 A range for larger units.

- A. Set the anticipator at its highest setting.
- B. Disconnect the "W1" thermostat wire from the furnace low voltage terminal connections.
- C. Connect the AC meter between the "W1" terminal on the board and the loose "W1" wire.
- D. Turn the thermostat up to start the furnace and allow it to run, with all elements on, for three or four minutes.
- E. Read the current draw on the meter and reset the anticipator to match the meter reading.

6. USE IN MOBILE HOMES

Models 21B10M, 21B15M, 21B18M & 21B20M are certified for "L"-shape and "T"-shape shallow duct installation with model FSB-1 sub-base in downflow applications when the supply air ducts pass through the floor of the structure. Recommended size of a floor opening: 14¼" x 14¼" (362 mm x 362 mm). The duct system must be designed so that the external static pressure of the system does not exceed the maximum external static pressure of 0.50" W.C. (125 Pa).

SHALLOW DUCT AREA REQUIREMENTS	
DUCT DEPTH	DUCT WIDTH
4" (102 mm)	16" (406 mm)
5" (127 mm)	13" (330 mm)
6" (152 mm)	10" (254 mm)

7. USING OPTIONAL EQUIPMENT

7.1 TWO-STAGE OR OUTDOOR THERMOSTAT

(The **SEASON SELECT** switch must be in the **MILD** position).

These controls can be used on all furnaces except 10 kW model.

Follow the directions supplied with the two-stage or outdoor thermostat in conjunction with the furnace wiring diagram. When used, the furnace stage will supply heat as follows in the opposite chart:

Model	First Stage (kW)	Second Stage (kW)
10 kW	10	—
15 kW	10	5
18 kW	9	9
20 kW	10	10
25 kW	15	10
27 kW	13.5	13.5

7.2 AIR CONDITIONING

Your furnace is equipped with all the controls required for the addition of air conditioning (except the heat-cool thermostat).

The evaporator coil may be installed by a local contractor in sheet metal plenum of his own manufacture. The coil should be located: centred over the "chimney" of the furnace 4" (102 mm) to 6" (152 mm) above the top of the furnace.

Make sure no air is allowed to bypass the cooling coil during cooling operation. If the discharge opening is a great deal larger than the coil, and the ductwork is correspondingly larger than the coil, you may want to use a bypass damper for heating. The damper would be closed in summer, directing all air flow through the coil. In winter the damper would be open to allow air to bypass the coil.

Typical air-conditioning field wiring connections are shown in the diagram at right.

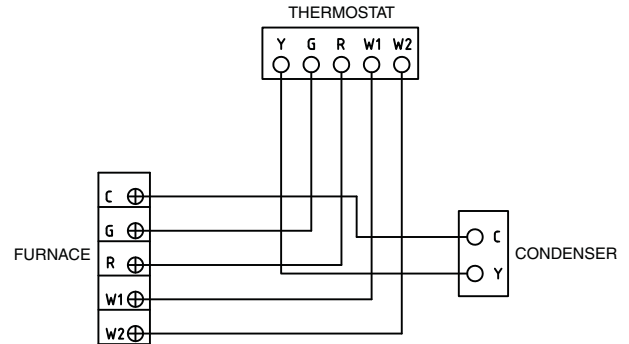

FE0001A

WIRING COLOR CODE					
C	G	R	W1	W2	Y
COMMON	GREEN	RED	WHITE	WHITE (BLUE OPTIONAL)	YELLOW

7.3 ELECTRONIC AIR CLEANERS AND/OR POWERED FURNACE HUMIDIFIERS

These units operate at 120 V. Your 240 V furnace is designed so that Model FK120 adaptor kit can be mounted inside the furnace to supply the required 120 V. Instructions for mounting and wiring are included with the kit. FK120 kit is not available for 83B 208 V three-phase models.

7.4 INTERLOCK CONNECTION

When the electric furnace is used in combination with another device (as for example, a wood burning furnace), it is recommended to perform the connection by referring to the wiring diagram at right. The burning furnace thermostat will then turn automatically on the blower in the electric furnace.

Also, please note that Norton has developed a low speed interlock kit; the FIK (Furnace Interlock Kit). This kit is specially designed to interlock the furnace operation with a ventilation fan or an HRV unit.

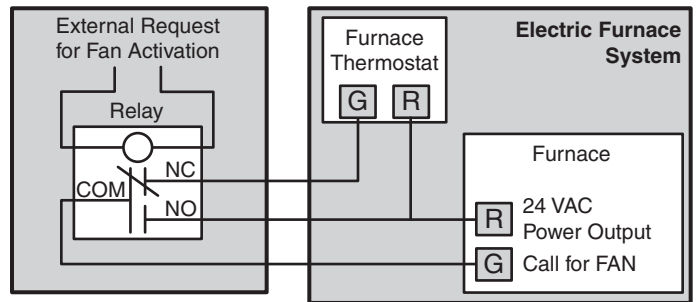

FE0034A

8. WIRING DIAGRAMS

⚠ WARNING

Risk of electric shock. Disconnect power before installation, servicing, maintenance or field wiring. Replace all panels before operating. Failure to do so can result in electric shock causing severe injuries or death.

21B10M Model

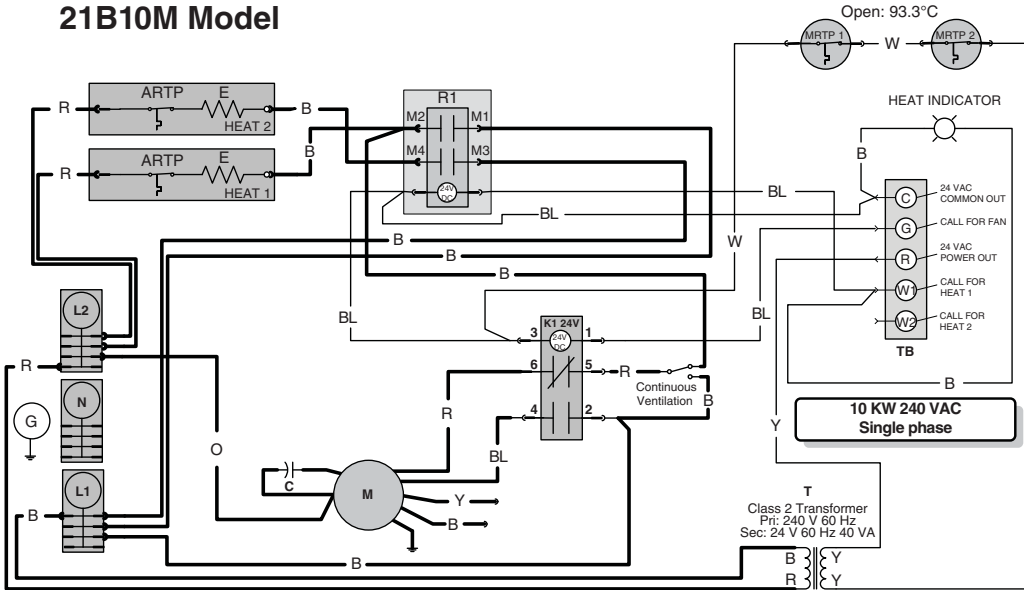

Critical characteristic

1. If any of the original wire, as supplied, must be replaced, use the same equivalent wire. Wiring must comply with applicable codes, ordinances and regulations.
2. Field wiring must comply with applicable codes, ordinances and regulations. Use only Class 1 wiring inside furnace compartments.

Line voltage wiring:
UL AWM 1015/1230, 600V, 105°C, VW-1, 12 AWG;
CSA TEW 600V, 105°C, FT1, 12 AWG.

Low voltage wiring:
same ratings as high voltage except 18 AWG.

21B15M Model

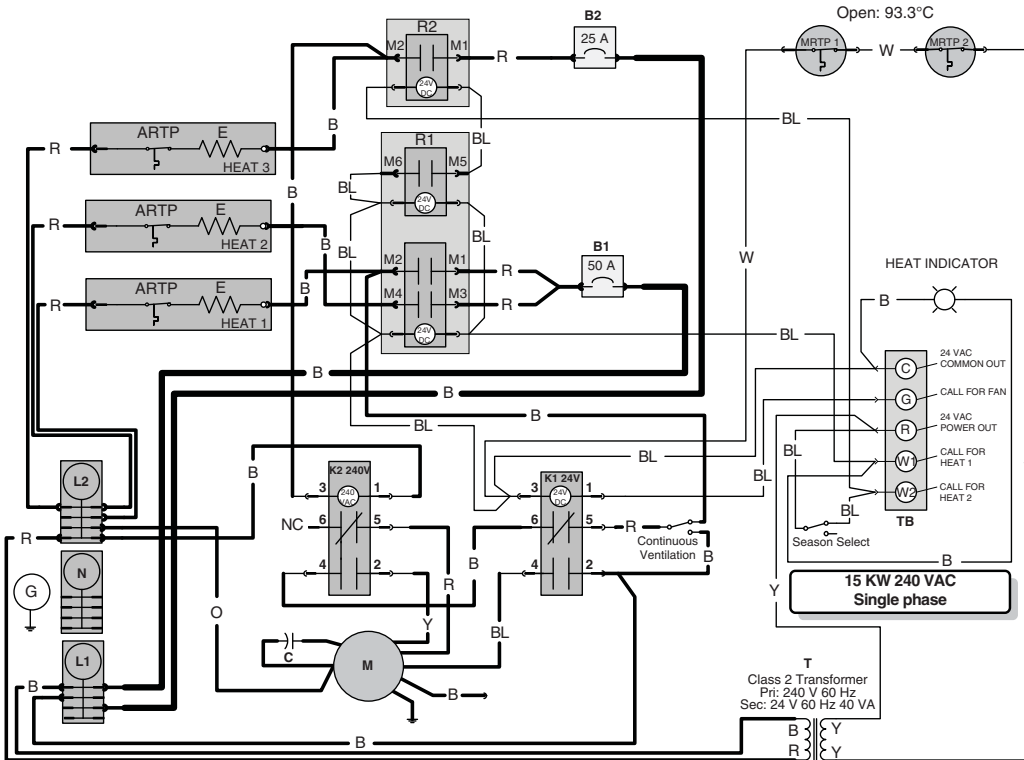

FAN MOTOR SPEED	COLOR
HI	BLACK
MED-HIGH	BLUE
MED-LOW	YELLOW
LOW	RED

LEGEND	
C	Capacitor
E	Heating Element
R	Time Delay Relay
K	Fan Relay
ARTP	Auto-Reset Thermal Protector
MRTP	Manual-Reset Thermal Protector
M	Fan Motor
TB	Terminal Block
T	Transformer Class 2
HEAT	Heat
L1, L2	240 V Line Supply
N	Neutral
B	Breaker

Low power

High power

High power 8 AWG

WIRING COLOR CODE	
B	BLACK
BL	BLUE
O	ORANGE
R	RED
W	WHITE
Y	YELLOW

For the use of a two-stage thermostat or an outdoor thermostat, connect between W1 and W2. Make sure that the Season Select switch is set to "Mild" position.

8. WIRING DIAGRAMS (CONT'D)

⚠ WARNING

Risk of electric shock. Disconnect power before installation, servicing, maintenance or field wiring. Replace all panels before operating. Failure to do so can result in electric shock causing severe injuries or death.

21B18M & 21B20M Models

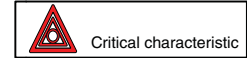
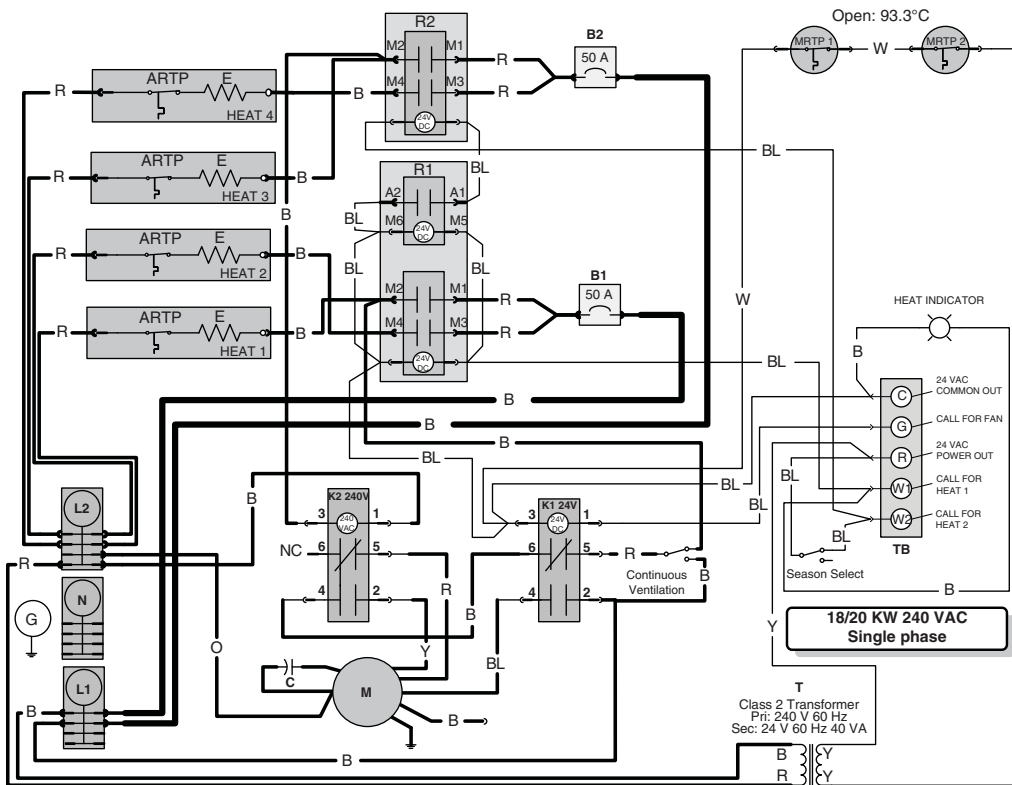

1. If any of the original wire, as supplied, must be replaced, use the same equivalent wire. Wiring must comply with applicable codes, ordinances and regulations.
2. Field wiring must comply with applicable codes, ordinances and regulations. Use only Class 1 wiring inside furnace compartments.

Line voltage wiring:
UL AWM 1015/1230, 600V, 105°C, VW-1, 12 AWG;
CSA TEW 600V, 105°C, FT1, 12 AWG.

Low voltage wiring:
same ratings as high voltage except 18 AWG.

FAN MOTOR SPEED	COLOR
HI	BLACK
MED-HIGH	BLUE
MED-LOW	YELLOW
LOW	RED

LEGEND

C	Capacitor
E	Heating Element
R	Time Delay Relay
K	Fan Relay
ARTP	Auto-Reset Thermal Protector
MRTP	Manual-Reset Thermal Protector
M	Fan Motor
TB	Terminal Block
T	Transformer Class 2
HEAT	Heat
L1, L2	240 V Line Supply
N	Neutral
B	Breaker

Low power
High power
High power 8 AWG

WIRING COLOR CODE

B BLACK
BL BLUE
O ORANGE
R RED
W WHITE
Y YELLOW

For the use of a two-stage thermostat or an outdoor thermostat, connect between W1 and W2. Make sure that the Season Select switch is set to "Mild" position.

21B25M Model

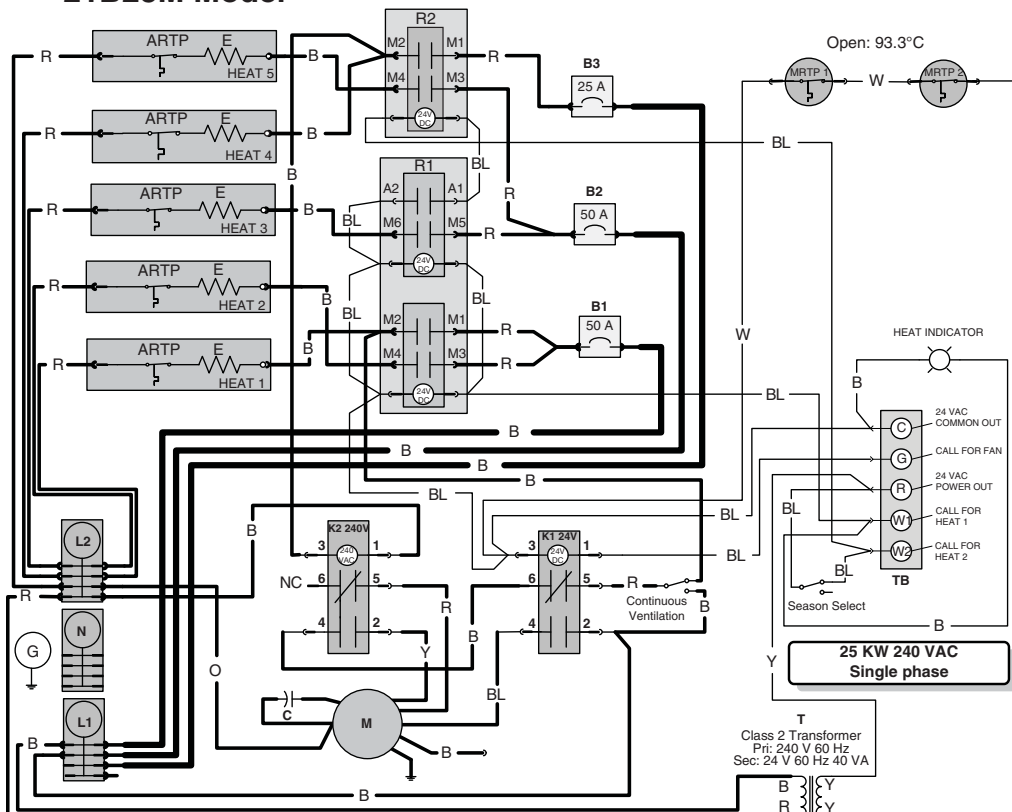

8. WIRING DIAGRAMS (CONT'D)

⚠ WARNING

Risk of electric shock. Disconnect power before installation, servicing, maintenance or field wiring. Replace all panels before operating. Failure to do so can result in electric shock causing severe injuries or death.

21B27M Model

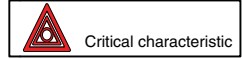
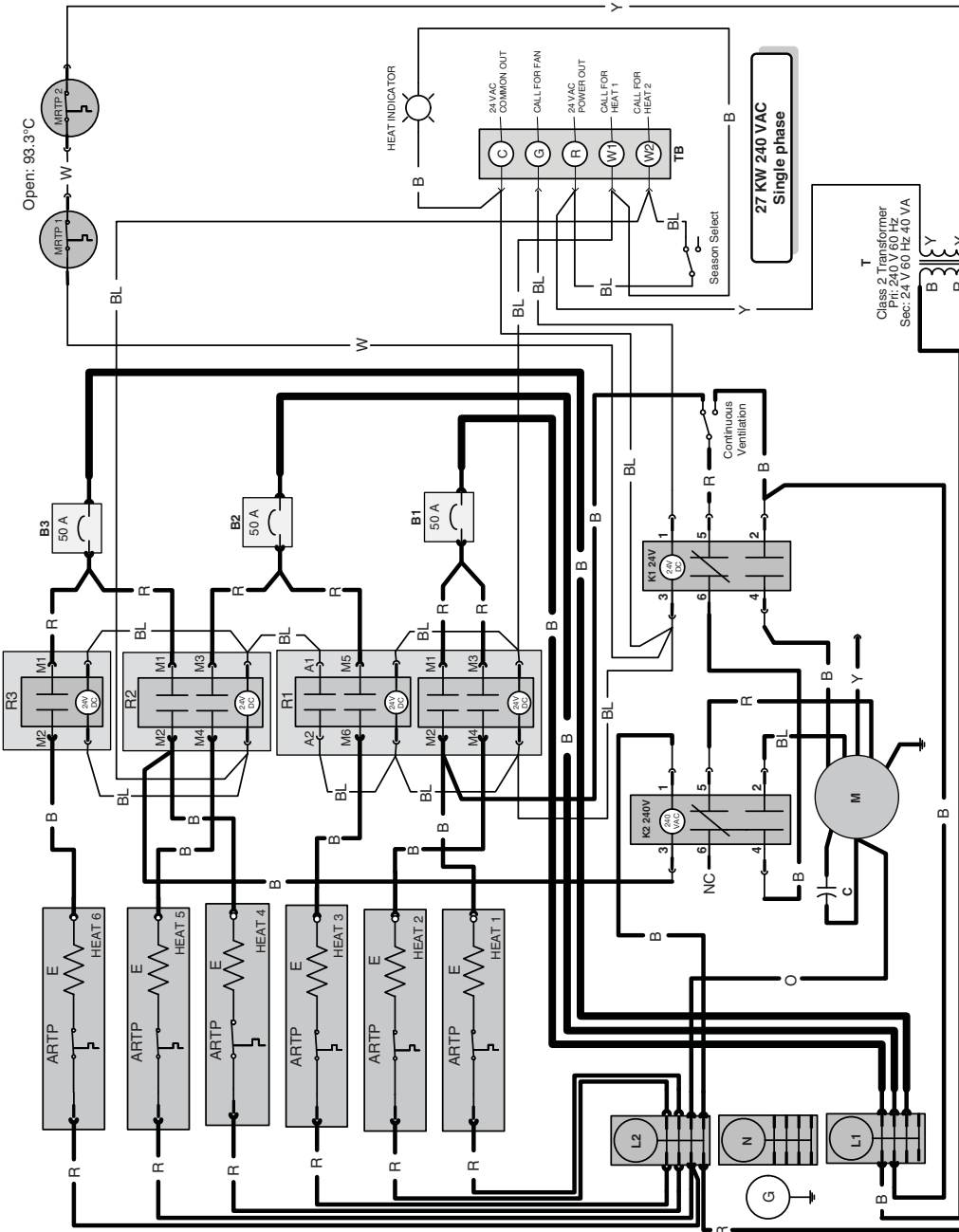

Critical characteristic

1. If any of the original wire, as supplied, must be replaced, use the same equivalent wire. Wiring must comply with applicable codes, ordinances and regulations.
2. Field wiring must comply with applicable codes, ordinances and regulations. Use only Class 1 wiring inside furnace compartments.

Line voltage wiring:
UL AWM 1015/1230, 600V, 105°C, VW-1, 12 AWG;
CSA TEW 600V, 105°C, FT1, 12 AWG.

Low voltage wiring:
same ratings as high voltage except 18 AWG.

FAN MOTOR SPEED	COLOR
HI	BLACK
MED-HIGH	BLUE
MED-LOW	YELLOW
LOW	RED

LEGEND	
C	Capacitor
E	Heating Element
R	Time Delay Relay
K	Fan Relay
ARTP	Auto-Reset Thermal Protector
MRTP	Manual-Reset Thermal Protector
M	Fan Motor
TB	Terminal Block
T	Transformer Class 2
HEAT	Heat
L1, L2	240 V Line Supply
N	Neutral
B	Breaker

Low power	
High power	
High power 8 AWG	

WIRING COLOR CODE	
B	BLACK
BL	BLUE
O	ORANGE
R	RED
W	WHITE
Y	YELLOW

For the use of a two-stage thermostat or an outdoor thermostat, connect between W1 and W2. Make sure that the Season Select switch is set to "Mild" position.

FE0047A

8. WIRING DIAGRAMS (CONT'D)

⚠ WARNING

Risk of electric shock. Disconnect power before installation, servicing, maintenance or field wiring. Replace all panels before operating. Failure to do so can result in electric shock causing severe injuries or death.

83B13 Model

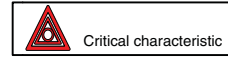
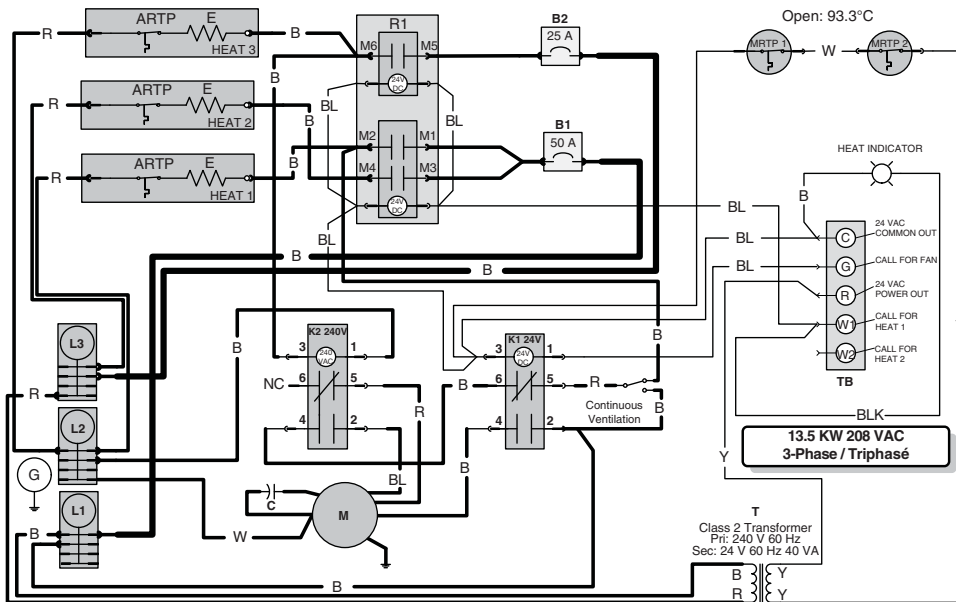

1. If any of the original wire, as supplied, must be replaced, use the same equivalent wire. Wiring must comply with applicable codes, ordinances and regulations.
2. Field wiring must comply with applicable codes, ordinances and regulations. Use only Class 1 wiring inside furnace compartments.

Line voltage wiring:
UL AWM 1015/1230, 600V, 105°C, VW-1, 12 AWG;
CSA TEW 600V, 105°C, FT1, 12 AWG.

Low voltage wiring:
same ratings as high voltage except 18 AWG.

FAN MOTOR SPEED	COLOR
HI	BLACK
MED-HIGH	BLUE
MED-LOW	YELLOW
LOW	RED

83B24 Model

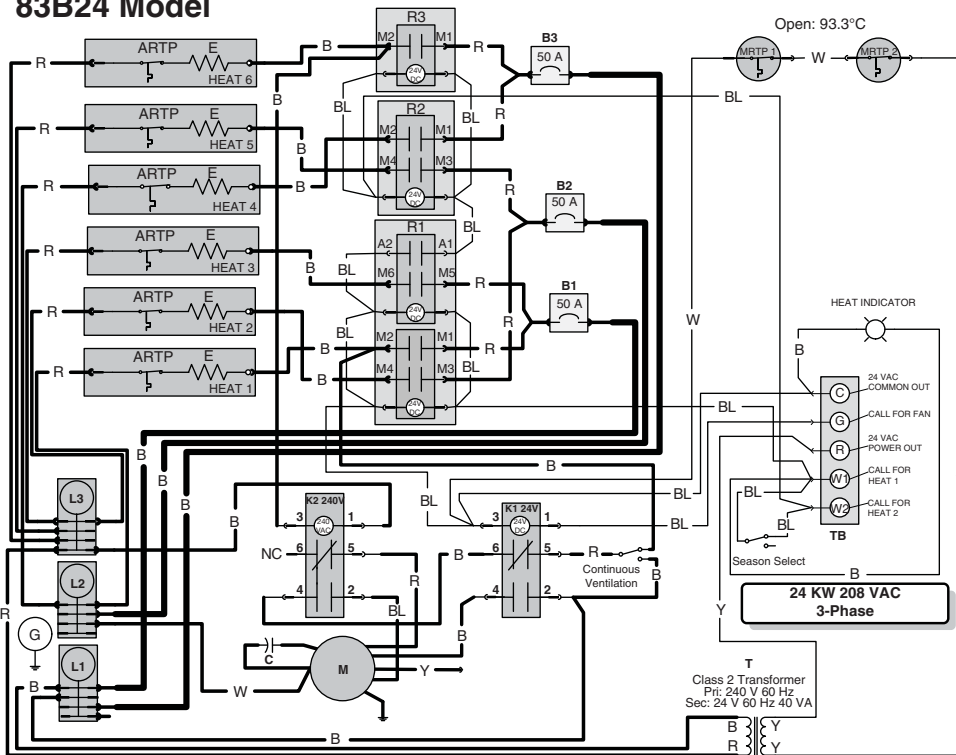

LEGEND

C	Capacitor
E	Heating Element
R	Time Delay Relay
K	Fan Relay
ARTP	Auto-Reset Thermal Protector
MRTP	Manual-Reset Thermal Protector
M	Fan Motor
TB	Terminal Block
T	Transformer Class 2
HEAT	Heat
L1, L2, L3	Line Supply 208 V 3-Phase
B	Breaker

Low power
High power
High power 8 AWG

WIRING COLOR CODE

B BLACK
BL BLUE
O ORANGE
R RED
W WHITE
Y YELLOW

83B27 Model

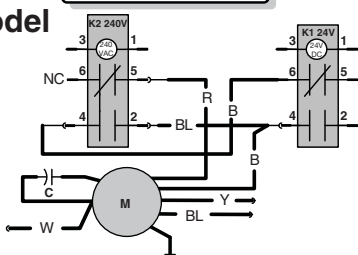

The wiring diagram for 27 KW model is the same as the one for 24 KW model, except for the motor (illustrated at left).

For the use of a two-stage thermostat or an outdoor thermostat, connect between W1 and W2.

Make sure that the Season Select switch is set to "Mild" position.

9. SERVICE PARTS

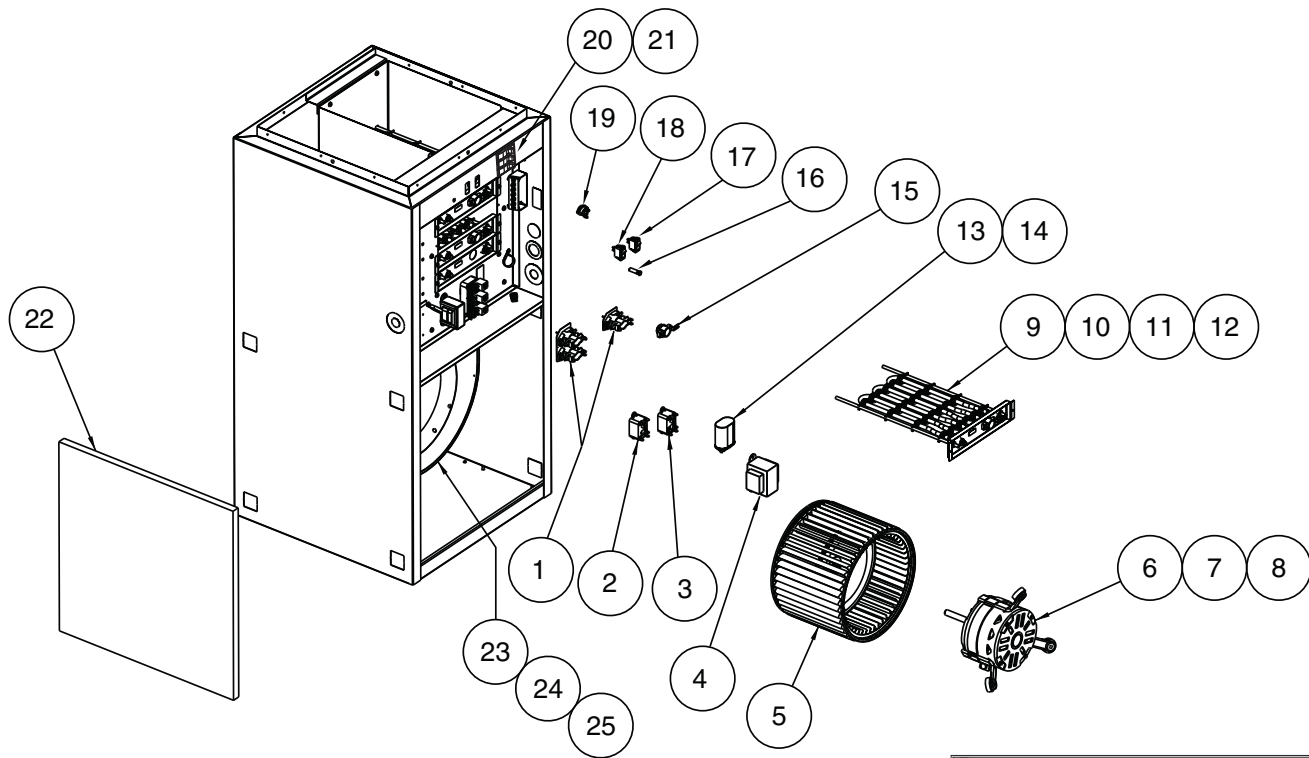

FL0018

REPLACEMENT PARTS AND REPAIRS

IN ORDER TO ENSURE YOUR UNIT REMAINS IN GOOD WORKING CONDITION, YOU MUST USE BROAN-NU TONE GENUINE REPLACEMENT PARTS ONLY. THE BROAN-NU TONE GENUINE REPLACEMENT PARTS ARE SPECIALLY DESIGNED FOR EACH UNIT AND ARE MANUFACTURED TO COMPLY WITH ALL THE APPLICABLE CERTIFICATION STANDARDS AND MAINTAIN A HIGH STANDARD OF SAFETY. ANY THIRD PARTY REPLACEMENT PART USED MAY CAUSE SERIOUS DAMAGE AND DRASTICALLY REDUCE THE PERFORMANCE LEVEL OF YOUR UNIT, WHICH WILL RESULT IN PREMATURE FAILING. ALSO, BROAN-NU TONE RECOMMENDS TO CONTACT A CERTIFIED SERVICE DEPOT FOR ALL REPLACEMENT PARTS AND REPAIRS.

REPLACEMENT PARTS				
TIME DELAY RELAYS (SEQUENCERS)				
KEY NO.	PART NO.	BOTTOM	SECOND	THIRD
1	30270025		B15	B24-B27
	30270026	B10	B18-B20-B25-B27	
	10940925	B15-B18-B20		
	10940926	B25-B27		

KEY NO.	PART NO.	DESCRIPTION
2	10940928	240 V Fan Relay (not in 21B10M)
3	10940927	24 V Fan Relay
4	30300022	Transformer 240 V
5	30390553	Blower Wheel 12" x 8" (305 mm x 203 mm) - for DD12 Blower
6	10941288	Motor 3/4 HP, 240 V - for 21B27MS
7	10941203	Motor 1/3 HP, 240 V - for 21B10M, 21B15M, 21B18M, 21B20M and 21B25M
8	30080025	Motor 1/3 HP, 208 V - for 83B Series
9	10940080	Element Assembly 5000 W, 240 V
10	10940081	Element Assembly 4500 W, 240 V
11	10940082	Element Assembly 4500 W, 208 V
12	10940083	Element Assembly 4000 W, 208 V
13	30270038	Capacitor for 1/3 HP Motor
14	30271114	Capacitor for 3/4 HP Motor
15	30270032	Automatic Limit

KEY NO.	PART NO.	DESCRIPTION
16	30280021	Thermostat Indicator Light
17	30030006	Season Select Switch
18	30030025	Continuous Ventilation Switch
19	30280020	Manual Reset Limit
20	30274191	Breaker 50 Amps
21	30274192	Breaker 25 Amps
22	30010010	Fiberglass Filter 20" x 20" x 1" (508 mm x 508 mm x 25 mm)
23	10941149	Service Blower Assembly DD10, 1/3 HP, 240 V
24	10941221	Service Blower Assembly for 21B27MS
25	10940353	Service Blower Assembly for 83B13, 83B24, 83B27
*	FIK	Furnace Interlock Kit (optional, purchase separately)
*	FK120	120 Volt Kit (optional, purchase separately)
*	10941381	Service Door for B Series

* Not illustrated

10. MAINTENANCE

MOTOR: The motor is lubricated for life and needs no oiling.

FILTERS: Size is 20" x 20" x 1" (508 mm x 508 mm x 25 mm). Should be inspected and replaced when dirty. Ordinarily replacement is required twice per heating season and, perhaps, a third time if continuous blower operation is used.

NOTE: Each element has an automatic reset thermal cut-out which is set to open at 160°F (71°C). If it opens, the element will be de-energized until the cut-out resets itself. In addition to that, there are 2 manual reset thermal cut-outs that open at 200°F (93°C). If any of them open, a front panel needs to be removed so the cut-out can be manually reset.

⚠ WARNING

Cut power supply (240 V or 208 V, according to the unit) before removing the front panel!

11. TROUBLESHOOTING

The first step in identifying an operational problem is to determine whether the fault is in the furnace or in the thermostat and/or its connecting wiring.

To help make this determination, the furnace is equipped with a "Thermostat ON" diagnostic light. If the light is "ON," it indicates the thermostat has closed and is calling for heat; the blower should be operating. If the light is "OFF," the furnace should not be operating—unless the **CONTINUOUS VENTILATION** switch is set to run the motor continuously.

1. If the furnace will not start:

Turn the thermostat to its highest setting. If the light goes on, the thermostat has closed, so the fault is in the furnace. If the light does not go on, the thermostat or its connecting wiring is the problem.

2. If the furnace will not turn off:

Turn the thermostat to its lowest setting. If the light goes off and the furnace continues to run, the thermostat has opened properly and the problem resides in the furnace. If the light stays on, the fault is in the thermostat or its connecting wiring.

After the fault area is isolated by use of the diagnostic light, a check of the following components can be made more efficiently.

PROBLEM	POSSIBLE DEFECTIVE PARTS OR COMPONENTS
1. The furnace will not turn on.	<ul style="list-style-type: none"> • Thermostat • Circuit breaker or fuse is open • CONTINUOUS VENTILATION switch (open contact) • Bottom Sequencer • Transformer
2. Motor runs continuously.	<ul style="list-style-type: none"> • CONTINUOUS VENTILATION switch is not on OFF position • Thermostat wires incorrectly attached to the furnace • Bottom sequencer (the bottom heating element would also remain on) • 24 V Relay
3. Elements on, but motor does not run.	<ul style="list-style-type: none"> • Motor or capacitor • CONTINUOUS VENTILATION switch (open contact) • Bottom sequencer
4. Motor going on and off in short cycles (or in too long cycles)	<ul style="list-style-type: none"> • Heat anticipator in thermostat incorrectly set or may be defective
5. The thermostat must be set much higher (or lower) than the desired house temperature	<ul style="list-style-type: none"> • The thermostat is not leveled or out of calibration
6. Not enough heat	<ul style="list-style-type: none"> • One or more defective elements or sequencers • SEASON SELECT switch set in MILD position • Safety limits opening because duct obstruction or dirty filters are restricting air flow • Defective or incorrect wired two-stage or outdoor thermostat • Lack of enough cold air returns in house
7. Two-stage or outdoor thermostat not operating properly	<ul style="list-style-type: none"> • SEASON SELECT switch not set in MILD position
8. Motor goes off, but one or more elements stay on	<ul style="list-style-type: none"> • Sequencer
9. Automatic speed change doesn't occur when furnace heats up	<ul style="list-style-type: none"> • Top sequencer • 240 V relay
10. Thermal cut-out opens	<ul style="list-style-type: none"> • Airflow is reduced because of blocked ductwork or very dirty filters
11. Breaker on front panel trips	<ul style="list-style-type: none"> • Overcurrent on heating element. Reset the breaker. If problem persists, call an electrician

12. WARRANTY

NORTRON by **BROAN**

SIXTY-MONTH LIMITED WARRANTY FOR NORTRON PRODUCTS

Broan-NuTone Canada (Broan-NuTone) warrants to the original consumer purchaser of Nortron products that such products will be free from defects in materials or workmanship for a period of sixty (60) months from the date of original purchase. THERE ARE NO OTHER WARRANTIES, EXPRESS OR IMPLIED, INCLUDING, BUT NOT LIMITED TO, IMPLIED WARRANTIES OR MERCHANTABILITY OR FITNESS FOR A PARTICULAR PURPOSE.

During this sixty-month period, Broan-NuTone will, at its option, repair or replace without charge, any product or part which is found to be defective under normal use and service. This product or part should be shipped prepaid by the customer to the company factory or the nearest authorized service center.

THIS WARRANTY DOES NOT EXTEND TO FILTERS, FURNACE KITS SOLD SEPARATELY, DUCTS, AND ACCESSORIES FOR DUCTING. This warranty does not cover (a) normal maintenance and service or (b) any products or parts which have been subject to misuse, negligence, accident, improper maintenance or repair (other than by Broan-NuTone), faulty installation or installation contrary to recommended installation instructions. Broan-NuTone does not accept any responsibility for transportation of repaired part or replaced product mentioned above and for reinstallation costs.

The duration of any implied warranty is limited to the sixty-month period as specified for the express warranty. Some jurisdictions do not allow limitation on how long an implied warranty lasts, so the above limitation may not apply to you.

BROAN-NUTONE'S OBLIGATION TO REPAIR OR REPLACE, AT BROAN-NUTONE'S OPTION, SHALL BE THE PURCHASER'S SOLE AND EXCLUSIVE REMEDY UNDER THIS WARRANTY. BROAN-NUTONE SHALL NOT BE LIABLE FOR INCIDENTAL, CONSEQUENTIAL OR SPECIAL DAMAGES ARISING OUT OF OR IN CONNECTION WITH PRODUCT USE OR PERFORMANCE. Some jurisdictions do not allow the exclusion or limitation of incidental or consequential damages, so the above limitation or exclusion may not apply to you.

This warranty gives you specific legal rights, and you may also have other rights, which vary from province to another. This warranty supersedes all prior warranties, and applies only in Canada territorial limits.

To qualify for warranty service, you must (a) notify Broan-NuTone at the address or telephone number stated below, (b) give the model number and part identification and (c) describe the nature of any defect in the product or part. At the time of requesting warranty service, you must present evidence of the original purchase date.

Broan-NuTone Canada; 1140 Tristar Drive, Mississauga, ON L5T 1H9 www.broan.ca 877-896-1119