

XRL-240 LAMINATOR

OPERATING MANUAL

USE OF OPERATING MANUAL

This manual has been prepared as a guide in the use of the Western Magnum XRL-240 LAMINATOR and DRY FILM PHOTORESIST. The advice contained in this manual is furnished free and is based upon tests and information believed to be reliable. The customer should decide for his own purposes whether such advice is valid and suitable for each application. Western Magnum does not guarantee results and assumes no obligation or liability for this technical advice. All advice is given and is to be accepted at the customer's risk.

LIMITED WARRANTY

Western Magnum Corporation warrants all of its equipment to be free from defects in manufacture for a period of 90 days from date of delivery for initial installation.

This warranty applies to any defects of material or workmanship which appear under normal and proper use, unless caused by the fault or negligence of the customer, its agents, employees, licensees, or invitees.

Western Magnum's sole obligation under this warranty shall be to correct, at its expense, any defects of material or workmanship either by repair or replacement, at its option. This warranty does not include, and the user will be charged for, parts and labor service (including transportation) to replace expendable items (e.g., bulbs, rollers, gaskets).

Western Magnum shall not be liable for other damages, whether direct, indirect and/or consequential. This warranty is in lieu of any other warranties, express or implied, including any implied warranty of merchantability or fitness for a particular purpose, and of any other obligation or liability.

XRL-240 LAMINATOR OPERATING MANUAL

TABLE OF CONTENTS

- i. Use of Operating Manual
 - ii. Warranty
-
- I. INTRODUCTION TO THE XRL-240 LAMINATOR
 - A. General
 - B. Operating Safety
 - C. XRL-240 Specifications
 - D. DRY FILM PHOTORESIST
-
- II. INSTALLATION
 - A. Operating Site
 - B. Installation Procedure
-
- III. OPERATION
 - A. Safety
 - B. Thread Up Procedure
 - C. Laminating Operation
 - D. Shut Down Procedure

IV. MAINTENANCE

- A. Cleaning the XRL-240
- B. Lubricating the XRL-240

V. SERVICE

- A. Servicing the XRL-240
 - 1. Side Covers - Removal
 - 2. Pressure Roll Heater Elements - Removal
 - 3. Pressure Roll Heater Elements - Replacement
 - 4. Pressure Roll - Removal
 - 5. Pressure Roll - Installation
 - 6. Main Motor - Replacement
 - 7. Temperature Controllers - Adjustment
 - 8. Temperature Control Module - Replacement
 - 9. Temperature Sensor - Replacement
 - 10. Transport Speed System - Servicing
 - 11. Magnetic Clutch - Servicing
- B. XRL-240 Electrical
 - Diagram, wiring
 - Schematic, Electrical
 - Wire List
- C. Parts List

VI. SPARE PARTS

- A. Ordering Parts

ILLUSTRATIONS

<u>FIGURE</u>	<u>DESCRIPTION</u>
1	XRL-240 Front View
2	XRL-240 Right (control) Side
3	XRL-240 Left Side
4	XRL-240 Rear View
5	Dry Film Composition
6	Photoresist Thread Up Diagram
7	Collet Assembly - Supply Roll
8	Mandrel - Supply Roll
9	Heater and Slip Ring Assembly
10	Temperature Sensor Schematic
11	Wiring Diagram
12	Electrical Schematic
13	Control Panel
14	Illustrated Parts Diagram - Right Side
15	Illustrated Parts Diagram - Left Side
16	Illustrated Parts Diagram - Rear

SECTION I
INTRODUCTION

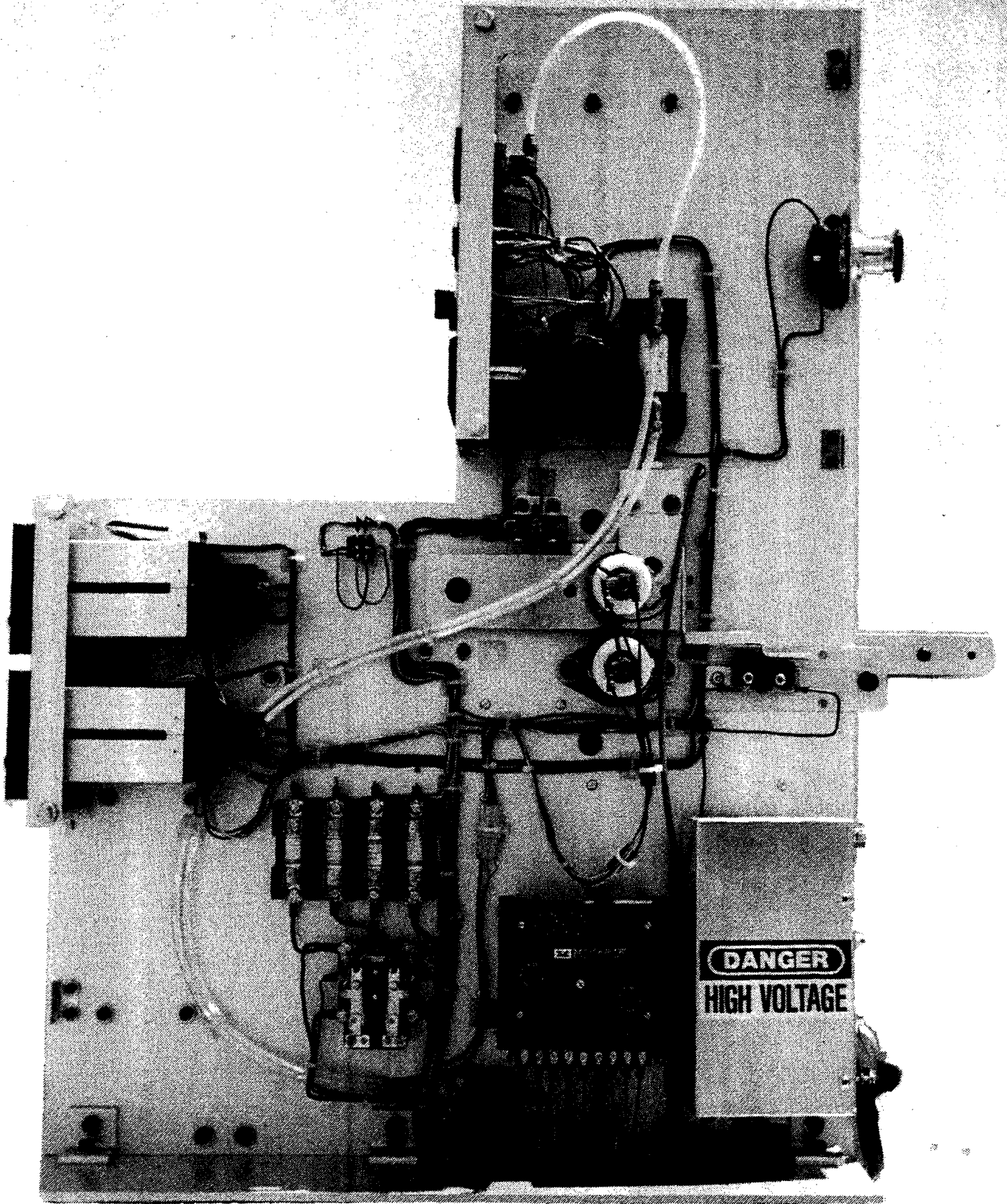

FIGURE 2
-4-

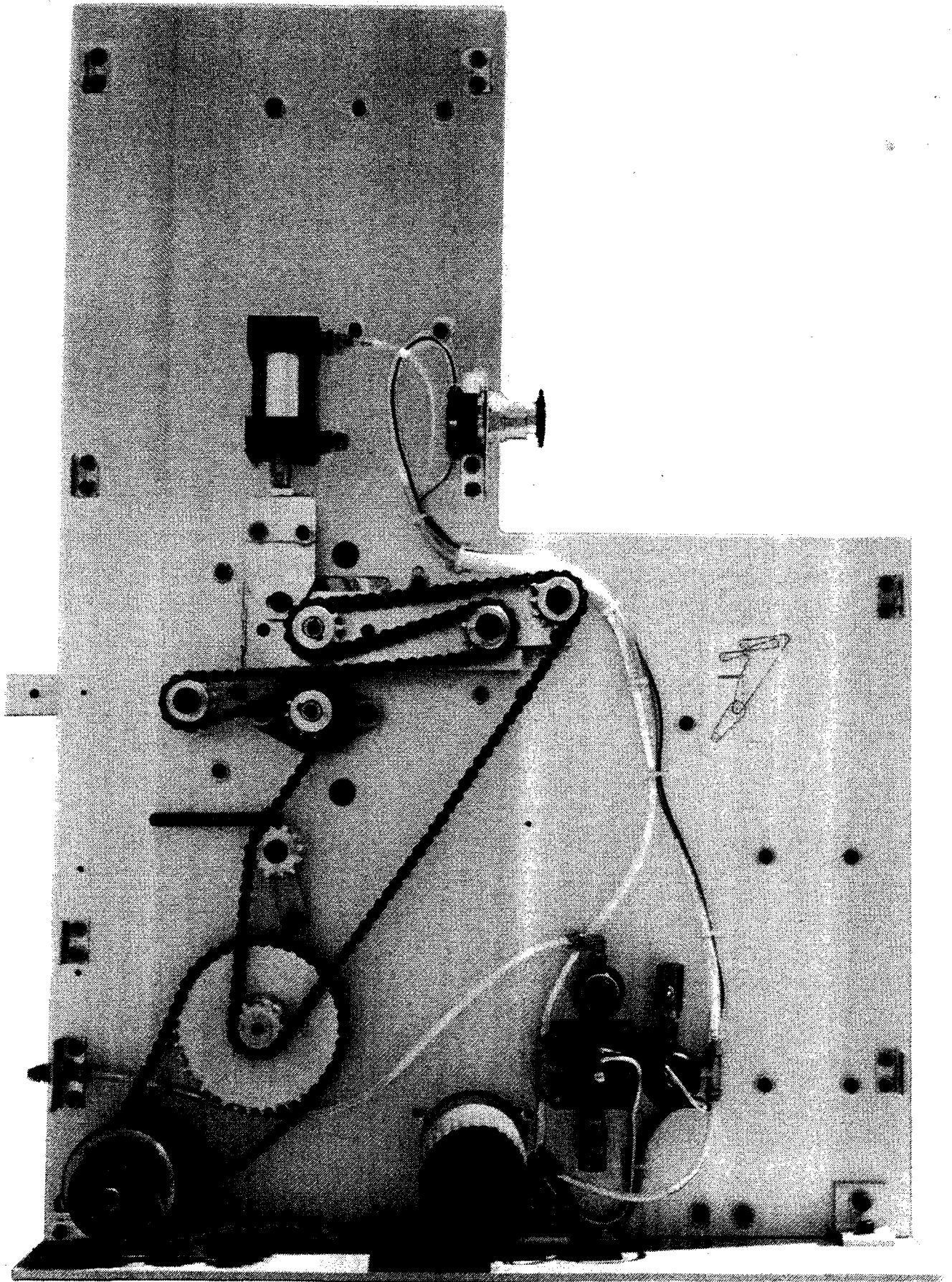

FIGURE 3

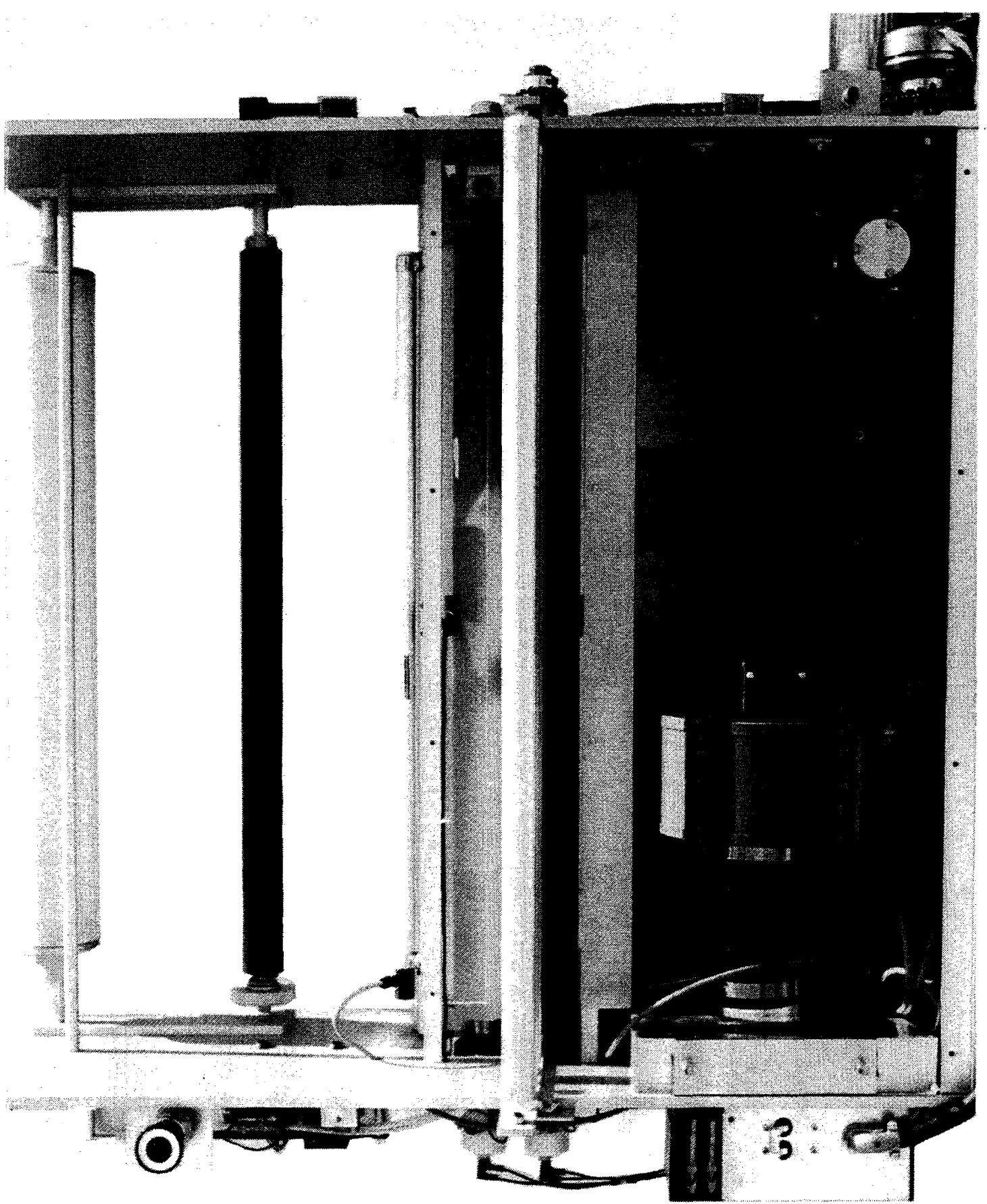

FIGURE 4

I. INTRODUCTION TO THE XRL-240 LAMINATOR

A. GENERAL

1. The XRL-240 LAMINATOR is designed for use with any DRY FILM PHOTORESIST. The Laminator is a new design incorporating significant improvements in dry film laminator technology. See Figure 1 for a photograph of the Laminator.
2. The XRL-240 uses heat and pressure to laminate DRY FILM PHOTORESIST to flexible or rigid materials up to 25 inches wide and 0.250 inches thick. Maximum Photoresist film width, 24 inches.
3. Materials typically laminated with DRY FILM PHOTORESIST include copper-clad laminate used in the manufacture of printed circuit boards and sheets or rolls of metal for chemical milling. Photoresist can be laminated to one or both sides of the working material in a single pass through the laminator.
4. Figures, 2, 3, and 4 show major features of the XRL-240 LAMINATOR.
5. The XRL-240 has two large diameter, internally heated Pressure Rolls with roll temperature controlled by two solid state, digital reading, potentiometric, input thermocouple temperature controllers. This combination of temperature and pressure provides optimum dry film lamination conditions. The heated Pressure Rolls are in intimate contact with the Photoresist for heat transfer to the Photoresist and the Printed Circuit Board. An air pressure system provides high unit pressure to the rollers to insure satisfactory Dry Film lamination. The transport speed system includes a digital readout of transport speed in feet per minute.

B. OPERATING SAFETY

The XRL-240 has been conceived with OPERATOR SAFETY as a key design goal. The machine can be stopped instantly from four separate positions: (1) Main Control Panel (front, right side of machine) (2) Emergency Off Switch (front, left side of machine) (3) Emergency Off Switch (rear, right side of machine) and (4) Main Circuit Breaker (rear, left side of machine).

In addition, the Pressure Roll REVERSE DRIVE Switch (right side plate) can be operated from either the front or back of the machine to reverse the direction of the laminating rollers (the power and drive switch must be ON).

An additional OPERATOR SAFETY FEATURE is provided by the placement of the fume exhaust duct and shield located directly in front of the pressure rolls. The fume duct and shield are positioned so operators can not get their hands or unwanted objects near the rollers. If the fume duct is removed, POWER TO THE MACHINE "DRIVE" WILL SHUT OFF.

As an extra precaution, the power plug should be disconnected before removing the duct when service is to be performed.

The XRL-240 also has a magnetic clutch in the drive system. Whenever power is shut off, the pressure rollers will become "free spinning" so nothing can get caught in the rollers. If any object were caught in the rollers, it could be readily pulled out after the Emergency Off Switch is hit.

C. XRL-240 SPECIFICATIONS

- (1) Dimensions: 44.25" W x 25" D x 37.5" H (112 cm x 63 cm x 95 cm).
- (2) Weight: 270 lbs: (122 kg); (Shipping Weight: 325 lbs. 147 kg).
- (3) Heater Capacity: Two (2) 1000 watt, 240 volt cartridge heaters (one for each pressure roller).
- (4) Laminating Temperature Range: ambient to 285 degrees F (140 degrees C).
- (5) Maximum Roll Speed Range: 0 to 12 fpm.
- (6) Roll Speed Working Range: 3 to 5 fpm.
- (7) Maximum PCB Panel Width: 25" (63 cm).
- (8) Electrical Requirements: 240 VAC, Single Phase 60/50 HZ, 10 amp.(15 service)

D. DRY FILM PHOTORESIST

1. Dry Film Photoresist is used to transfer design art work onto Printed Circuit Boards through a UV exposure process. The Dry Film Photoresist is sandwiched between a layer of polyethylene and a layer of polyethylene terephthalate (See Figure 5). The protective polyethylene cover is stripped off as the photoresist is being fed into the rolls. The polyethylene terephthalate cover sheet protects the photoresist from contamination and damage during lamination and exposure; it is peeled off just before development of the photoresist.

2. All operators are directed (or should be instructed by Supervisors) to discard both protective cover sheets after removal. DO NOT use these films for any other purpose as they are covered with trace amounts of photo sensitive materials.

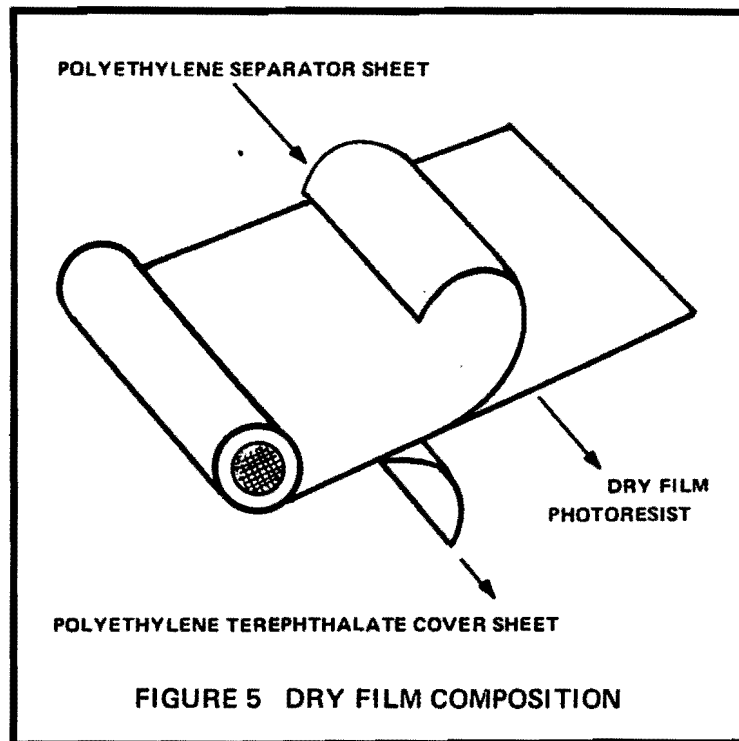

SECTION II
INSTALLATION

II. INSTALLATION

A. OPERATING SITE

1. Optimum Clearances: A work table of approximately 30" x 48 by 27" high is recommended for mounting the XRL-240. A three foot clearance on all sides is desirable.
2. Lighting: Since Dry Film Photoresist is photosensitive, the resist film must be used in work areas with only yellow light illumination (gold fluorescent bulbs). Do not allow white light or daylight to enter the work area when Photoresist is being used.

B. INSTALLATION PROCEDURE

1. The XRL-240 Laminator is shipped completely assembled. The Laminator has been thoroughly tested at the factory prior to shipping. Note: Immediately upon arrival open crate in delivery drivers presence and inspect the Laminator for damage and if damaged, file a claim with the carrier. Remove all shipping tiedowns. Place Laminator on work table. Adjust height of each foot to share the weight of the Laminator equally. Verify Laminator is level.
2. Connect the Laminator to a 240 VAC, 50/60 HZ, single phase electric supply line having 15 or 20 AMP circuit protection. Use the "twist-lock" receptacle supplied with the machine. This matches the line plug of the Laminator. Note: If the plant receptacle does not match the Laminator plug, replace the plant receptacle with that provided.
3. Check that the Pressure Roll thermocouples make good contact with the roll surfaces.
4. Verify that the Pressure Rolls are securely installed and do not shift from side to side. If necessary to tighten rolls, see Service Section V, A, 5 for details.

5. Remove Feed Roller Table and Fume Exhaust Duct for access to pressure rolls. Wash pressure rolls with a damp sponge rinsed in soap and water. After cleaning rolls, re-assemble Fume Duct and Feed Table.
6. Connect plant air supply (60-100 lbs.) to the 1/4" knurled nut compression fitting supplied on the unit (located in the circuit breaker panel in rear).
7. Place Laminator Circuit Breaker to ON. Push POWER Switch ON. (The amber light in the POWER Switch should glow). If it does not glow, check to see that both emergency off switches are pulled outward.
8. TEMPERATURE CONTROLLERS: Push HEAT Switch ON. The two LED displays will light up on each of the two controllers. The bottom LED will display the set-point temperature and the top will be the actual temperature for each pressure roller. Temperatures will be displayed in fahrenheit unless otherwise requested for centigrade.

NOTE: PLEASE SEE APPENDIX FOR COMPLETE USER'S MANUAL ON TEMPERATURE CONTROLLER

TEMPERATURE ADJUSTMENT: The temperature setting for each pressure roller can be adjusted on the top and bottom controller by pressing the up or down arrows on the face of the controller. The display on the bottom LED will change to a higher or lower set-point temperature as required to a maximum of 300°F (149°C).

9. AIR PRESSURE SYSTEM: Air cylinders mounted on each side of the frame apply pressure to the top roller bearing plates. An air regulator has been factory set to approximately 50 PSIG and should not require re-adjustment. A setting of 50 PSIG as indicated on the pressure gauge will provide approximately 86 pounds of force at the nip of the pressure rolls. CAUTION: Do not exceed 50 PSIG. If improper adhesion of Photoresist occurs, consult factory. The air solenoid valve is energized through the AIR rocker switch located at the top of the control panel. Push it up (ON) to close the pressure rollers and provide air assist. (see para 14)
10. Push DRIVE Switch ON. Set SPEED Control knob to mid range (approximately 6 Feet Per Minute). Rolls should turn freely, Transport Speed Indicator (digital readout) should read 6 FPM.

11. Run SPEED Control through entire speed range. Rolls should respond smoothly. Transport Speed Indicator should read speed setting of each point.
12. Push momentary REVERSE DRIVE Switch. Pressure Rolls should reverse direction smoothly.

Note: The Reverse Drive Switch is functional only when the DRIVE switch is ON.

13. On the right rear of the machine, approximately level with the exit tray, is the Air Actuation Panel Sensor Switch. This switch is adjusted by means of a thumb screw and wing nut and moves up and down in a slot. The switch changes the "set point" of a microswitch, which controls the ON/OFF of the air assist cylinders (paragraph 9 above). For thicker boards, the position of the switch is raised up and secured by the wing nut. This will turn the air pressure off until a panel is inserted in the rollers. When the upper roller is lifted by the board, the switch will energize and pressure will be applied. This provision is installed so that the thicker panels will start easier into the rollers.
14. Open the pressure rollers by pushing the AIR switch to the down position (OFF).
15. This completes the check out. The Laminator is ready for laminating DRY FILM PHOTORESIST.

SECTION III
OPERATION

III. OPERATION

A. SAFETY

1. Operators should read Section II, INSTALLATION, first, then proceed to this Section.
2. THROW CIRCUIT BREAKER OFF and DISCONNECT POWER CABLE before servicing the XRL-240.
3. The XRL-240 can be stopped instantly from four separate positions: (1) Main Control Panel (front, right side) (2) Emergency Off Switch (rear, right side) (3) Emergency Off Switch (front, left side) and (4) Main Circuit Breaker (rear, left side). The XRL-240 has a magnetic drive clutch. Whenever the power is shut off (as specified just above) the pressure rolls are free spinning, enabling anything caught in the rolls to be pulled out. CAUTION: The rollers are very hot and will take considerable time to cool down.
4. The Pressure Roll REVERSE DRIVE Switch located on right side plate can be operated from either the front or back of the machine to reverse the rolls. NOTE: POWER and DRIVE SWITCHES must be ON to operate the REVERSE DRIVE function.
5. ALWAYS DISCARD the polyethylene protective covering and the polyethylene terephthalate cover sheet after removal from photoresist rolls.
6. DO NOT wear loose clothing or jewelry while operating or servicing the laminator.
7. KEEP AWAY from hot laminating rolls. (Rolls operate at about 235° F and can burn the skin of a careless operator).
8. WASH THOROUGHLY with soap and water after handling Photoresist materials.

B. THREAD UP PROCEDURE

1. ASSURE THAT POWER IS DISCONNECTED. Refer to the PHOTORESIST THREAD UP DIAGRAM (Figure 6) for the proper procedure to thread up the Laminator.
2. Remove adjustable Feed Table and Fume Duct. Place nearby.
3. Place both empty Take-Up Rolls in their respective utility groves.
4. Be sure top and bottom Photoresist Supply Mandrels are oriented correctly, i.e., the Tension Control Knobs on each mandrel are on the right hand side. NOTE: When loaded with Photoresist, the Supply Mandrels are NOT interchangeable.
5. Loading Bottom Supply Mandrel:
 - (a) Position roll of Dry Film Photoresist so it unwinds from bottom toward the laminating roll.
 - (b) Lift Bottom Supply Mandrel from Laminator; remove left collet assembly. (See Figure 7 - Collet Assembly drawing).
 - (c) Place Photoresist rolls onto Supply Mandrel; replace left collet assembly; be sure tension control knob is on the right. (See Figure 8 - Supply Mandrel Assembly).
 - (d) Center the Photoresist roll on the Supply Mandrel.
 - (e) Replace Supply Mandrel on the Laminator.
 - (f) Thread Dry Film Photoresist around lower stripper bar.
 - (g) Using two pieces of masking tape on a corner of the photoresist, separate the polyethylene cover sheet from the Dry Film.
 - (h) Tape polyethylene cover sheet to Bottom Takeup Roll.
 - (i) Pull an adequate amount of Dry Film Photoresist from Supply Mandrel to fold into a "V" and push "V" between separated pressure rollers.

FIGURE 6 PHOTORESIST THREAD UP DIAGRAM

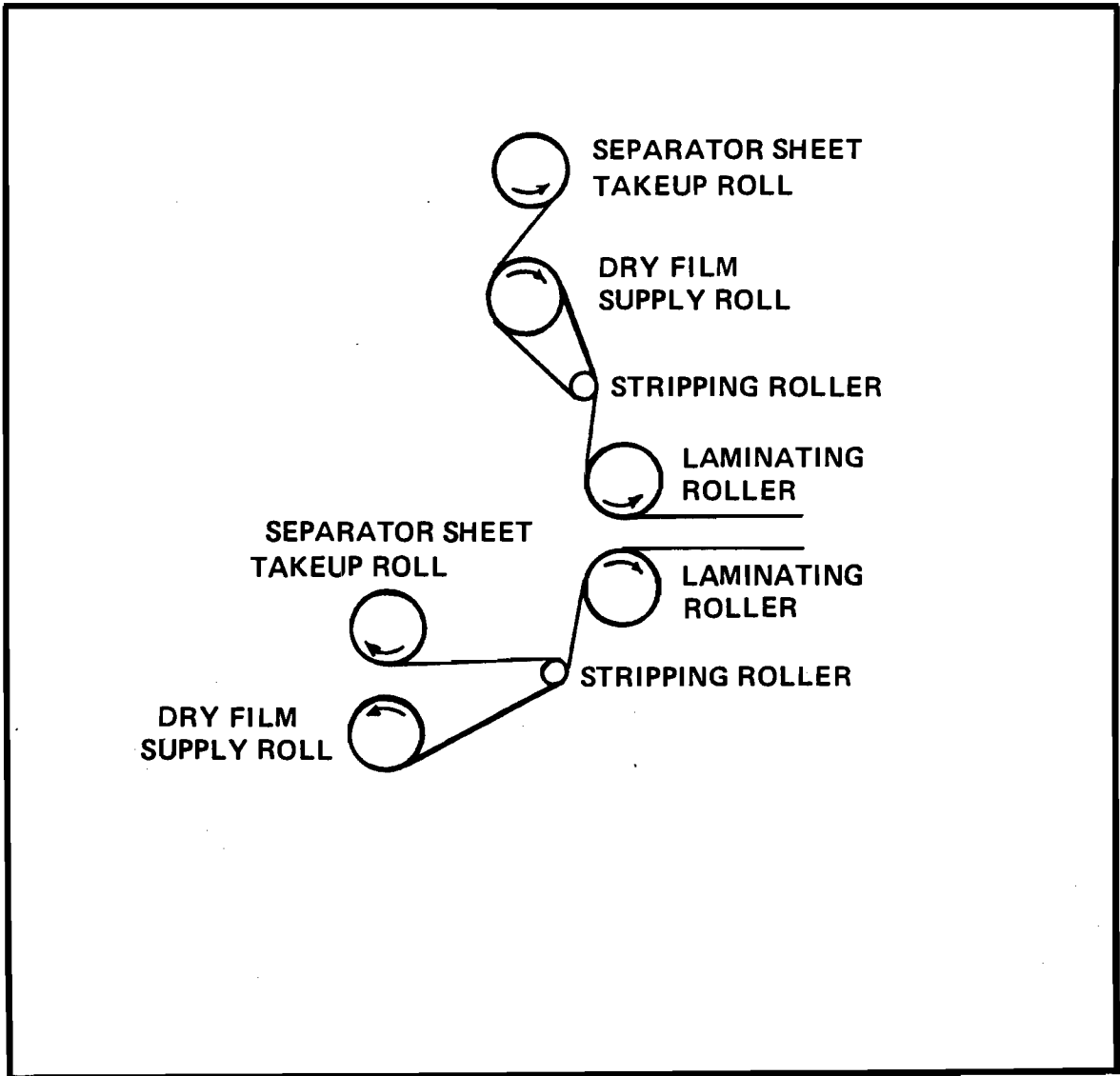

FIGURE 6
PHOTORESIST THREAD UP DIAGRAM

NOTE:

3 INCH COLLET ASSEMBLY SHOWN.
FOR 6 INCH COLLET ASSEMBLY SUBSTITUTE
240-0095 EXPANSION RING FOR 240-0085
AND 240-0246 O'RING FOR 240-0245.

PN 240-0092 3" CORE ASSY
PN 240-0092-3 6" CORE ASSY

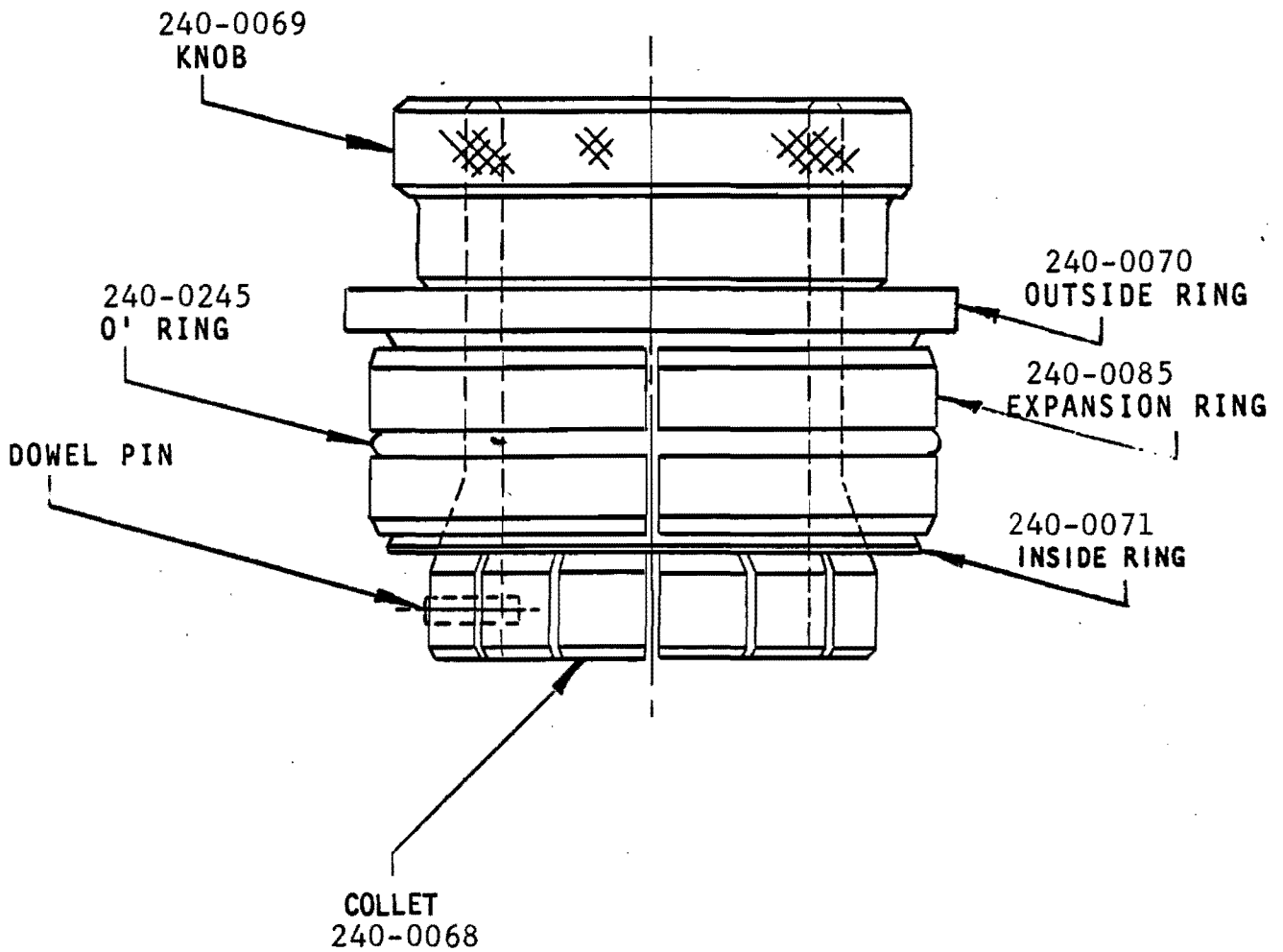
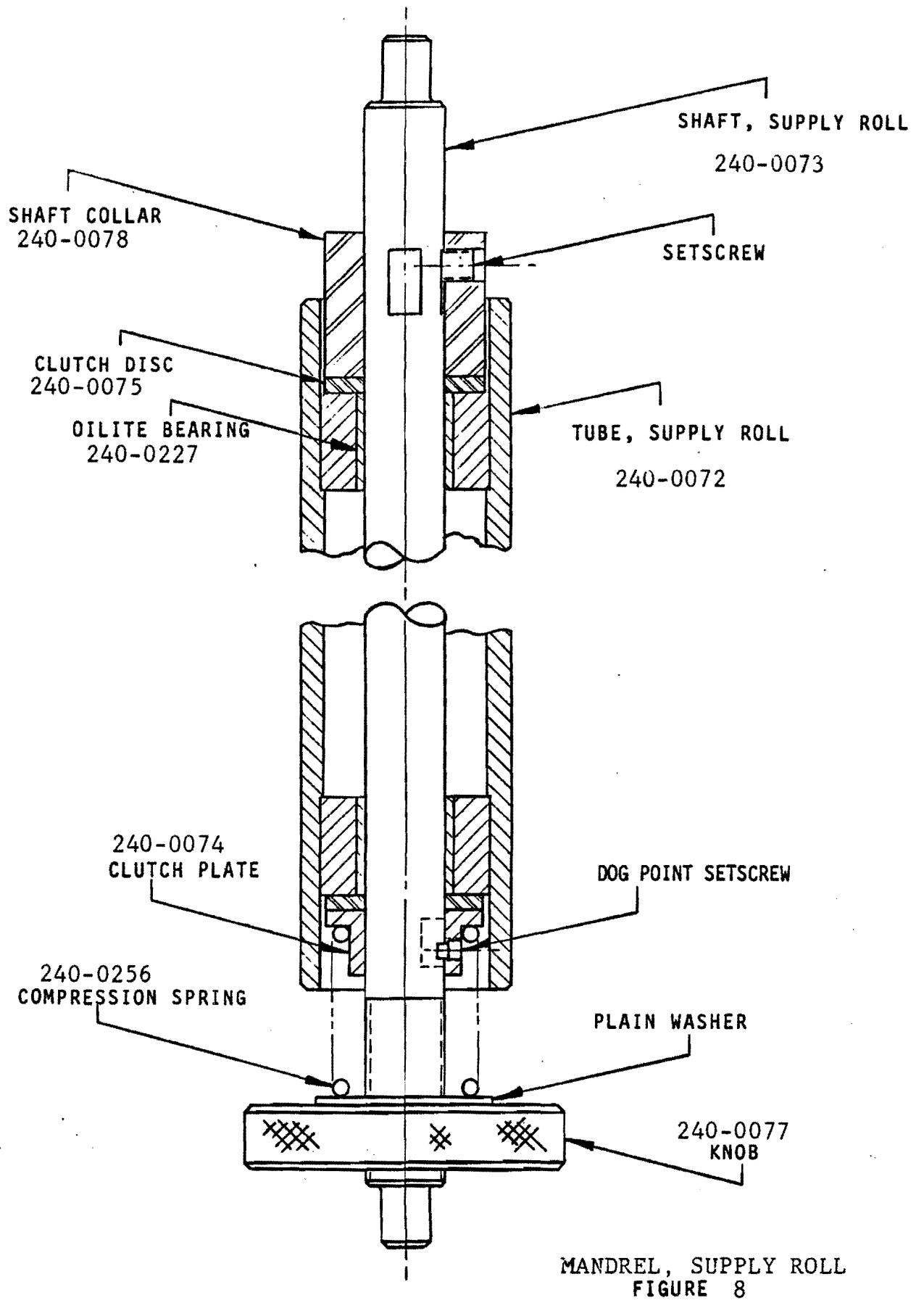

FIGURE 7

COLLET ASSEMBLY, SUPPLY ROLL



MANDREL, SUPPLY ROLL
FIGURE 8

(j) Place Bottom Take up Roll into deep slots so it rests on the Dry Film roll.

(k) Take up cover sheet slack on Take up Roll.

6. Loading Upper Supply Mandrel:

(a) Position roll of Dry Film Photoresist so it unwinds from rear toward laminating roll. (See Figure 6).

(b) Lift Top Supply Mandrel from Laminator; remove left collet assembly.

(c) Place Photoresist roll onto Supply Mandrel; replace left collet assembly. Be sure tension control knob is on the right.

(d) Center the Photoresist roll on Supply Mandrel.

(e) Verify that both Top and Bottom Photoresist rolls are aligned laterally with each other.(You may place one roll on top of other roll prior to # 5 above to obtain near compatible alignment).

(f) Replace Supply Mandrel in the Laminator.

(g) Thread Dry Film Photoresist around upper stripper bar.

(h) Using two pieces of masking tape on a corner of the photoresist, separate the polyethylene cover sheet from the Dry Film.

(i) Tape polyethylene cover sheet to Top Takeup Roll. Turn roll to take up slack in cover sheet.

(j) Pull an adequate amount of Dry Film Photoresist from both Supply Mandrels to fold into a "V".

(k) With Pressure Rolls open, push Dry Film through the roll gap.

(l) Place Top Take up Roll into deep slots so it rests on the Dry Film roll.

(m) Take up cover sheet slack on Take up Roll.

(n) Verify the alignment of the Top and Bottom Dry Film Photoresist with each other; if necessary, move one of the Dry Film rolls laterally on its respective Supply Mandrel to make the Dry Film edge alignment exact.

7. Pull several inches of Dry Film through Pressure Rolls (to prevent Dry Film wrap around).
8. Replace Fume Exhaust Duct and Feed Roller Table.
9. CONNECT POWER TO LAMINATOR.
10. With Speed Control at Zero, turn DRIVE Switch ON.
11. Turn Air Switch ON closing pressure rolls.
12. Run several feet of Dry Film through the Laminator at low speed until major wrinkles are gone; opening and closing Pressure Rolls while the DRIVE is ON helps dissipate wrinkles.
13. Dry Film Photoresist web tension is controlled by the Tension Control knobs on the right end of each Supply Mandrel. Proper tension is mandatory to eliminate wrinkles in the Photoresist. Too great a pressure from the Tension Control Knob will cause the Photoresist to stretch and possibly wrinkle. Too little tension can also allow the Photoresist to wrinkle when laminated to the PC Board. To correct for Photoresist wrinkling caused by too much tension, turn the Tension Control Knob counterclockwise until the web no longer stretches. To correct for too little tension, turn the knob clockwise.

NOTE

Too much tension can result in poor adhesion of the Photoresist at the edge of the Board. Proper tension is the MINIMUM tension which will avoid wrinkling of the photoresist on the laminated surface of the PC Board.

14. Verify the edges of the two sheets of Dry Film Photoresist remain aligned.
15. Adjust the guide on Feed Table for PC Board width.
16. Recheck Photoresist Thread Up Diagram to verify the Dry Film has been threaded properly.

C. LAMINATING OPERATION

1. Double sided lamination.
 - (a) POWER Switch ON.
 - (b) HEAT Switch ON: allow 15-20 minutes for Pressure Rolls to heat up and the temperature to stabilize; the Laminator is ready when both temperature controller load lights have been cycling ON and OFF.
 - (c) Verify that Photoresist edges are aligned evenly.
 - (d) Set the adjustable Feed Table Guides to the PC Board width.
 - (e) AIR Switch ON.
 - (f) DRIVE Switch ON; select proper Speed setting. NOTE: Thicker PC Boards require more heat for proper lamination than do thinner boards. For thicker boards slow down roll speed by turning SPEED control knob counterclockwise, to about 3 FPM. This permits longer contact with the heated roller, transfers more heat to the board and results in better Photoresist adhesion.
 - (g) Feed PC Board into Laminator, guiding the board against the guide on the Feed Table. NOTE: DO NOT force PCBs into the roller nip. The dual driven rolls will pull the PCB into and through the rolls. (thicker panels excepted)
 - (h) As the front edge of the laminated PC Board exits from the Pressure Rolls across the Exit Table, cut the excess Photoresist Film across the leading edge. Trim the Photoresist flush, leaving no overhang or tails.
 - (i) As the trailing edge of the laminated PC Board exits from the Pressure Rolls, cut the Photoresist film across the trailing edge.
 - (j) OPERATORS SHOULD BE INSTRUCTED TO TAKE GREAT CARE IN TRIMMING PCB'S AS THEY EXIT THE PRESSURE ROLLS TO AVOID DAMAGE TO THE RUBBER COVERED ROLLS. OPERATORS SHOULD ALLOW THE COPPER BOARDS TO MOVE WELL CLEAR OF THE PRESSURE ROLLS BEFORE TRIMMING THE PHOTORESIST.

2. Single sided lamination.

- (a) To prevent Photoresist from transferring to the Pressure Rolls, a back-up paper is required on the side opposite the Photoresist roll. For this type operation, mount a roll of paper, wider than the resist, on the opposite Supply Mandrel and allow the paper to advance with the Photoresist. A hard finish, dust free paper or polyester type film is adviseable.
- (b) Proceed as in paragraph III, C (1)

D. SHUT DOWN PROCEDURE

To shut down the XRL-240 Laminator:

- (1) Push HEAT Switch OFF.
- (2) Push DRIVE Switch OFF.
- (3) Push POWER Switch OFF.

NOTE: When shutting down for overnight or other extended periods of non-use, also Switch CIRCUIT BREAKER OFF and external AIR supply OFF.

SECTION IV
MAINTENANCE

IV. MAINTENANCE

A. CLEANING THE XRL-240

1. PRESSURE ROLLS are the single most important part of the XRL-240 Laminator to keep clean. Lamination results can be adversely affected by dirty Pressure Rolls. Use the following procedures:
 - (a) Turn the DRIVE Switch OFF, the POWER Switch OFF and the CIRCUIT Breakers OFF. For added safety, disconnect the power cord.
 - (b) Remove the Feed Table and the Fume Exhaust Duct.
 - (c) Clean the rolls with mild soap and water or mild solvent (use a damp sponge or lintless cloth).
 - (d) Rotate the Pressure Rolls by turning them by hand to a new roll area to be cleaned, and continue cleaning the new section of roller.

CAUTION

DO NOT clean the Pressure Rolls while power is connected to the laminator.

DO NOT clean the Pressure Rolls while they are hot.

DO NOT use a razor blade or knife to scrape the Pressure Rolls.

2. The XRL-240 Laminator should be kept clean at all times so that no dust or chips accumulate on the working surfaces. Such debris can adversely affect lamination results. Use the following procedures daily before starting the Laminator:
 - (a) With a damp sponge wipe : the Feed Table and Exit Table working surfaces and rollers; the Stripper Bars; Take up Rolls; Supply Mandrels; side plates; front and back Access Covers.

- (b) If necessary, a cloth dampened with Trichlorethane or Methylene Chloride may be used on everything except plastic parts to remove particles of resist on working surfaces.

NOTE

Use Neoprene gloves when handling solvents or cleaning resist condensate.

AVOID getting resist condensate or solvents on bare skin. If it should get on the skin inadvertently, wash immediately with soap and water.

AVOID breathing solvent or resist fumes. Insure adequate ventilation.

DO NOT use any solvent on HOT surfaces; clean the parts only when they have cooled down.

3. Inspect the Photoresist condensate filter monthly and clean as necessary.

SECTION V

SERVICE

V. SERVICE

CAUTION

Always turn CIRCUIT BREAKER to OFF and DISCONNECT POWER PLUG from receptacle before working on the XRL-240 LAMINATOR.

A. SERVICING THE XRL-240

1. Side Covers - Removal

- (a) Turn CIRCUIT BREAKER to OFF and DISCONNECT POWER CORD.
- (b) Remove the right SIDE COVER (Control Side) by unscrewing attaching screws and then pull cover off (be careful of wire bundles).
- (c) Remove the left SIDE COVER by unscrewing attaching screws and pulling cover off.

2. Pressure Roll Heater Element - Removal

- (a) Turn CIRCUIT BREAKER to OFF and DISCONNECT POWER CORD.
- (b) Remove both Side Covers.
- (c) Disconnect the heater wires from the shaft and slip ring coupling. (See Figure 9 - Heater and Slip Ring Installation drawing).
- (d) Loosen set screws on slip ring coupling; slide slip ring coupling and connectors from Roll Shaft.
- (e) Remove heater element by pulling on heater end; DO NOT pull on heater wires. The Heater is covered with a coating of Heat Transfer Compound and should slide out easily. If heater does not come out easily, proceed to step (f).
- (f) On left side, remove Screw Plug from drive end of pressure Roll Shaft. Insert a metal rod 3/16" diameter in the center of the shaft to push the heater element out.

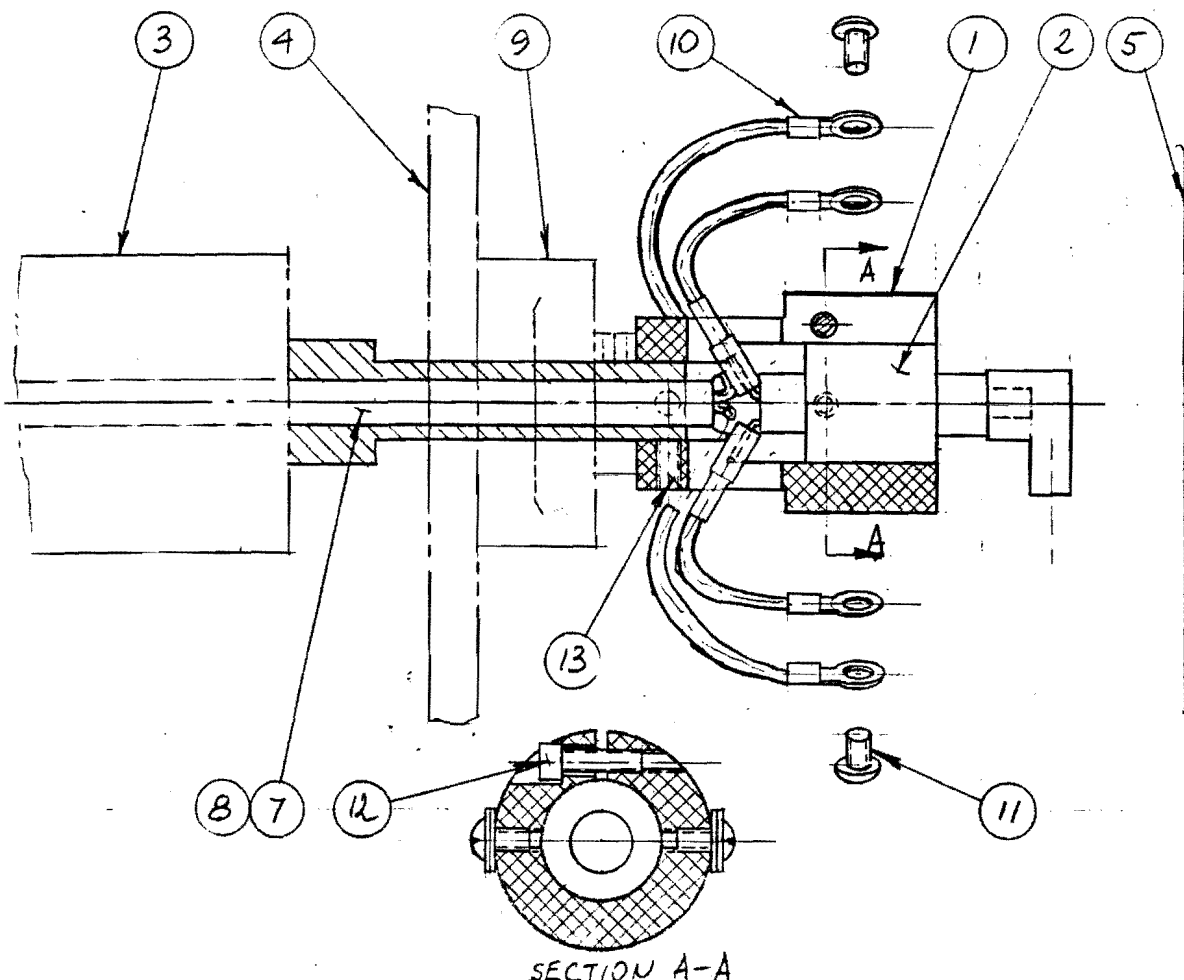

DATE	BY	REVISION RECORD	AUTH.	DR.	CK.
1/98		ROLLER -1 TO -3			
1/98		COMPOUND -1			

13	2	#10-32 x 3/8 LG	SETScrew, HEX SOCKET
12	1	#8-32 x 3/4 LG	SCREW, HEX SOCKET HEAD CAP
11	2	#8-32 x 3/8 LG	SCREW, BUTTOM HEAD CAP
10	4	22-16-AWG	RING TERMINAL #10
9	1	240-0218	FLANGE BEARING
8	A/R	240-0253	COMPOUND, HEAT TRANSFER
7	1	240-0204	HEATER, 1000W, 240V, 3 1/2 LG
6	1	550-0514	Connector, 90 degree
5	1	245-0008	SIDE COVER, RIGHT
4	1	245-0005	SIDE PLATE, RIGHT
3	1	240-0017-3	ROLLER, PRESSURE (HEATED)
2	1	245-0520	SLIP RING
1	1	245-0042	COUPLING, SHAFT

TOLERANCES (EXCEPT AS NOTED)		WESTERN MAGNUM CORPORATION	
DECIMAL		SCALE	DRAWN BY GY
±		FULL	APPROVED BY
FRACTIONAL		TITLE	
±		INSTALLATION HEATER & SLIP RING	
ANGULAR	DATE	DRAWING NUMBER	
±	03/17/87	245-0020	

NOTES:
 1. COMPLETELY COAT ITEM 7 (HEATER) WITH 240-0253-1 COMPOUND

FIGURE 9

28A

CAUTION

Excessive tapping might mushroom the end of the heater inside of the shaft, making it extremely difficult to remove the heater.

- (g) Pull heater out the right (Control) side.
- (h) If applicable, repeat above steps for removing second Heater.

3. Pressure Roll Heater Element - Replacement

- (a) Clean Heater element thoroughly before installing.
- (b) Use Heat Transfer Compound (P/N 240-0253-1) to coat the Heater element thoroughly as it is being inserted into the Pressure Roll Shaft.
- (c) Start the Heater into the shaft while coating Heat Transfer Compound on the Heater as it is pushed into the shaft. Twist the Heater element slowly as it is being inserted. Make sure that a uniform coating of the Heat Transfer Compound is on the Heater to insure proper roll heating.
- (d) Push Heater into Pressure Roll shaft leaving approximately 1/4" showing at the lead end.
- (e) Clean all excess Heat Transfer Compound from the end of Heater element.

CAUTION

The Heat Transfer Compound is electrically conductive so it must be thoroughly cleaned off all electrical leads, electrical connections and component surfaces.

- (f) Attach and tighten set screws on slip ring coupling.
- (g) Fasten Heater lead wires with supply wires to the slip ring coupling.
- (h) Re-install Screw Plug in drive end of Pressure Roll shaft (left end of the shaft).

4. Pressure Roll - Removal

- (a) Turn Circuit Breaker OFF and DISCONNECT POWER CORD.
- (b) Remove both Side Covers.
- (c) If heater element is to be reused, remove Heater element before roll removal as detailed above.
- (d) Lift Feed Table and Fume Exhaust Duct out of Laminator and set them aside.
- (e) Remove Grounding Brush (P/N 240-0250) from the respective Pressure Roll (near left end of roll inside of Side Plate).
- (f) Disconnect heater wires from slip ring coupling. Loosen set screws on Slip Ring Coupling and remove Slip Ring Coupling from Pressure Roll shaft.
- (g) On drive (left) side, disconnect Chain Tension Idler Spring.
- (h) Remove the Drive Chain.
- (i) Remove the Drive Sprocket from the Pressure Roll.
- (j) Remove shoulder screws securing lifter to bearing plate on each side of the Laminator. Remove lifter plates.
- (k) Loosen setscrews on bearing block on left side.

NOTE

There are no setscrews on right side to allow Pressure Rolls to expand when heated.

- (l) Remove shoulder screw and idler sprocket on left side bearing plate at pivot and remove bearing plate with bearing block attached.
- (m) Slide Pressure Roll out through left side of Laminator being careful not to bend or disrupt thermocouple assembly riding on roll.

NOTE

If bottom Pressure Roll is also to be removed, follow the applicable steps above and proceed as follows:

- (n) Loosen setscrews on bearing block.
- (o) Remove both lower bearing blocks on each side of Laminator and lift bottom Pressure Roll out through same opening used for the top roll, being careful not to disrupt the lower Roll thermocouple assembly.

5. Pressure Roll - Installation

- (a) Reverse the steps V,A, 4 - above to re-install the Pressure Rolls. In addition do the following.
- (b) The Pressure Rolls should be centered with respect to the side frames, i.e., the roll end is equal distance from each side frame, and the roll ends are aligned one to the other. Tighten Set Screws on ONLY the left side Bearing Block to avoid lateral shifting.
- (c) Replace the Pressure Roll drive sprocket. Align the sprocket with that of the opposite Pressure Roll sprocket.
- (d) Position the Temperature Thermocouple.
- (e) Replace the Grounding Brush.
- (f) Replace the Drive Chain.
- (g) Replace the Chain Tensioner Spring.

6. Main Motor - Replacement

- (a) Turn Circuit Breaker OFF and DISCONNECT POWER CORD.
- (b) Remove left Side Cover.
- (c) Remove Rear Cover.
- (d) Remove Short Drive Chain.
- (e) Remove Motor Drive Sprocket, Encoder and Safety clutch.
- (f) Remove electrical leads to Motor.
- (g) Remove motor mounting bolts.
- (h) Remove Main Motor.

- (i) To replace Main Motor, reverse the above steps.
- (j) Make sure Motor Drive Sprocket aligns with other drive sprockets and Chain Tensioner Sprocket.

7. Temperature Controllers - Adjustment

The temperature can be adjusted by depressing either the up or down arrows on the face of each controller. The bottom LED display will indicate the set-point temperature as it is changed.

NOTE: PLEASE SEE APPENDIX FOR COMPLETE USER'S MANUAL ON TEMPERATURE CONTROLLER

8. Temperature Control Module XRL-240 - Replacement

- (a) Turn Circuit Breaker OFF and DISCONNECT POWER CORD.
- (b) Remove wires from terminal Strip of Controller.
- (c) Loosen screws securing controller to panel.
- (d) Reverse above steps to re-install new Temperature Control Module.

NOTE: If the controller housing is not faulty it may stay in place and the controller module itself can be changed. One screw on the bottom of the controller face is loosened and the module will pull out of the housing.

9. Temperature Sensor - Replacement

- (a) The Temperature Sensor (see Figure 10) comes as a unit composed of a flexible stainless steel bracket and a copper heat sink, to which is soldered the Type J (iron-constantan) Thermocouple. The Thermocouple lead (white/red) is routed back to the connector screws of the Temperature Controller. The negative lead is colored red.
- (b) To replace the Temperature Sensor, unscrew the Thermocouple leads from the Temperature Controller, disconnect the tie downs holding the lead wire in place, and carefully pull the lead wire out of its routing holes.

FIGURE 10 TEMPERATURE SENSOR SCHEMATIC

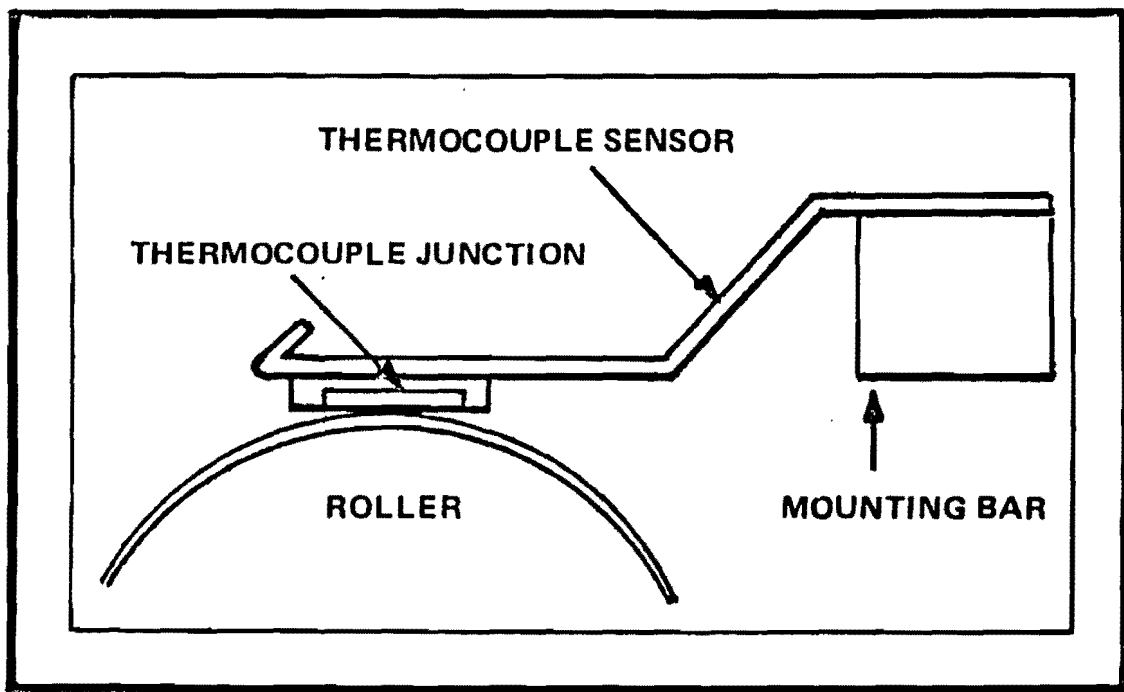

NOTE

The face of thermocouple junction is covered with teflon tape so that resist material will not stick to the copper disc and cause damage to the roller. BE SURE that the teflon tape is kept clean. Replace tape with new teflon tape if it becomes worn or damaged.

FIGURE 10
TEMPERATURE SENSOR SCHEMATIC

- (c) Unscrew the two screws holding the stainless steel bracket to the square laminator cross bar.
- (d) Remove the Temperature Sensor assembly from the Laminator.
- (e) Reverse above steps to replace the Temperature Sensor with a new unit.

10. Transport Speed System - Servicing

- (a) The Transport Speed System uses a illuminated digital display with a bi-directional, rotary optical encoder mounted on the rotating motor shaft of the laminator. The device is calibrated in Feet Per Minute (FPM). The programmable settings are made at the factory and should not require any adjustment.

11. Magnetic Clutch - Servicing

- (a) A type SL 30 shaft mounted magnetic clutch provides 125 lb-in torque (static) in the roller drive system. The clutch draws .091 amps at 90 VDC. The air gap in the clutch is set by the manufacturer. The clutch is installed for safety purposes so the pressure rollers will turn freely if power is turned OFF.
- (b) If slipping of the rollers should occur, verify first that the entire chain drive system is functioning properly and there is no binding of any of the chain sprockets. Next verify that the roll bearing blocks are functioning properly and have not slipped askew.
- (c) If all parts of the drive system are functioning properly, then the clutch might be slipping. In this case replace the clutch with (P/N 240-0342).
- (d) If the magnetic clutch fails to operate, the full wave rectifier that provides power to the clutch may have failed. This part is mounted on the right side plate under the side cover. (P/N 240-0343). Replace as necessary.

B. XRL-240 Electrical

- Diagram, Wiring (Figure 11)
- Schematic, electrical (Figure 12)
- Wire List

DATE	REVISION	REASON
1/8/91	1	TEMPERATURE 345

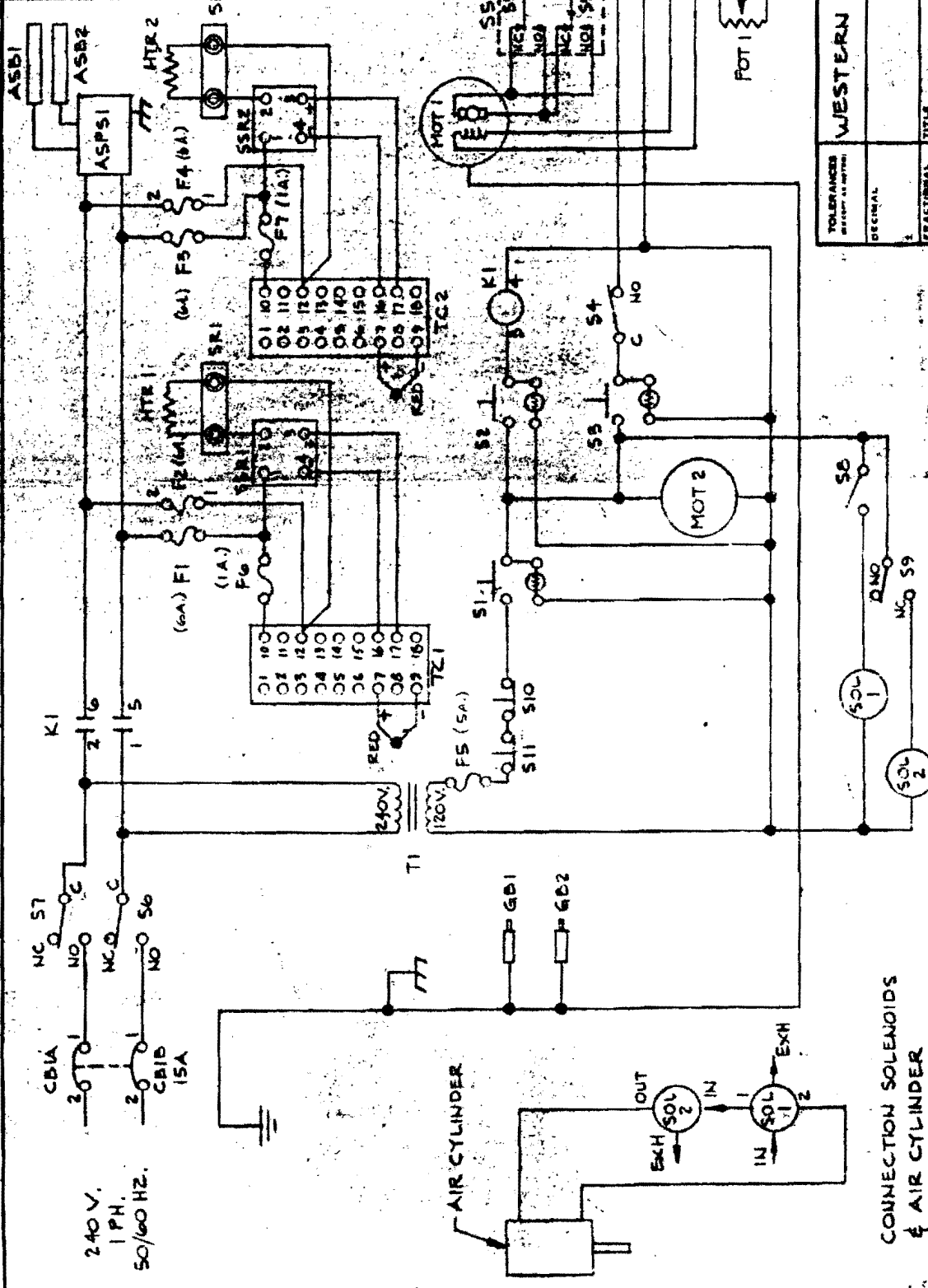

TOLERANCES UNLESS OTHERWISE SPECIFIED	WESTERN MAGNUM CORPORATION
DECIMAL	SCALE NONE
FRACTIONAL	APPROVED BY J. P. BRAWLEY
ANGULAR	TITLE SCHEMATIC ELECTRICAL - MODEL XRL 240
DATE 1/8/91	DRAWING NUMBER 1245-0003 C

CONNECTION SOLENOIDS
OF AIR CYLINDER

WIRE LIST

Model XRL-240 Hot Roll Laminator

No.	COLOR	FROM	TO
1	Black	P1-X	CB1B-2
2	White	P1-Y	CB1A-2
3	Green	P1	G1(Ground)
4	Green	TB2-13	G1(Ground)
5	Green	TB2-14	GB2
6	Green	TB2-14	GB1
7	Green	TB2-13	M1
8	Black	TB2-12	M1
9	Red	TB2-11	M1
10	White	TB2-10	M1
11	Brown	TB2-9	M1
12	Orange	TB2-12	M1
13	Orange/White	TB2-11	S5A-NC
14	Brown/White	TB2-10	MC1-F1
15	Brown	TB2-9	MC1-F2
16	Gray	TB2-8	S10
17	Gray	TB2-8	S1
18	Black	TB2-3	F5
19	Black	T1	TB2-3
20	Black	T1	TB2-4
21	Black/White	TB2-5	K1-4
22	Black/White	K1-4	MC1-L2
23	Black/White	K1-4	S2-B

WIRE LIST (con't)

<u>No.</u>	<u>COLOR</u>	<u>FROM</u>	<u>TO</u>
25	Black/White	S1-B	S3-B
26	Red	T1	TB2-2
27	Red	TB2-2	TB1-4
28	Red	TB1-3	K1-2
29	Red	T1	TB2-1
30	Red	TB2-1	TB1-2
31	Red	TB1-1	K1-1
32	Gray/White	TB2-6	S-2
33	Gray/White	S1	S2
34	Gray/White	S2	S3
35	Gray/White	S3	S1-A
36	Gray/White	M2	TB2-5
37	Purple	MC1-P1	P1-1
38	Green/White	MC1-P2	P1-2
39	Purple/White	MC1-P3	P1-3
40	Yellow	S4	S3
41	Yellow	S3	S3-A
42	Red/White	MC1-A2	S5B-C
43	Red	MC1-A1	S5A-C
44	Black	K1-3	S2
45	Black	S2	S2-A
46	Yellow/White	TC1-12	F1
47	Yellow/White	F1	HTR-1
48	Yellow	TC1-12	F3
49	Yellow	F3	HTR-2
50	Red	K1-6	F2-2

WIRE LIST (con't)

<u>No.</u>	<u>COLOR</u>	<u>FROM</u>	<u>TO</u>
51	Red	K1-6	F2-2
52	Purple	F7	TC2-10
53	Black/White	SSR1-4	TC1-16
54	Purple/White	F6	TC1-10
55	Red/White	SSR1-3	TC1-17
56	Blue/White	SSR1-2	HTR-1
57	Blue	SSR2-2	HTR-2
58	Red	TC1-11	TS1
59	White	TC1-9	TS1
60	Red	TC2-11	TS2
61	White	TC2-9	TS2
62	Red	CB1B-1	S7-N0
63	Red	S7-C	TB1-1
64	Red	CB1A-1	S6-N0
65	Red	S6-N0	TB1-4
66	Orange	S5A-NC	S5B-NC
67	Orange/White	S5A-N0	S5B-NC
68	Red/White	M2	TB2-6
69	Brown	S3	S8-A
70	Orange	S8-A	S9-C
71	Gray	S3	TSI 1
72	Brown/White	S8-B	SOL1
73	White	SOL1	TB2-4
74	Red	K1-5	F3
75	Red	K1-5	F1
76	Black	CPS1-5	CL1

WIRE LIST (con't)

<u>No.</u>	<u>COLOR</u>	<u>FROM</u>	<u>TO</u>
77	Black	CPS1-1	CL1
78	Black/White	S11	S 10
79	Black	SPS1-3	MC1-L1
80	Black	SPS1-7	MC1-L2
81	Black	K1-5	ASPS1
82	White	K1-6	ASPS1
83			
84			
85			
86			
87			
88			
89			
90			
91	Black	F5	S11
92			
93	Black	SSR2-4	TC2-16
94	Red	SSR2-3	TC2-17
95			
96	Purple/White	F2	F6
97	Purple/White	SSR1-1	F2
98	Purple	F4	F7
99	Purple	SSR2-1	F4

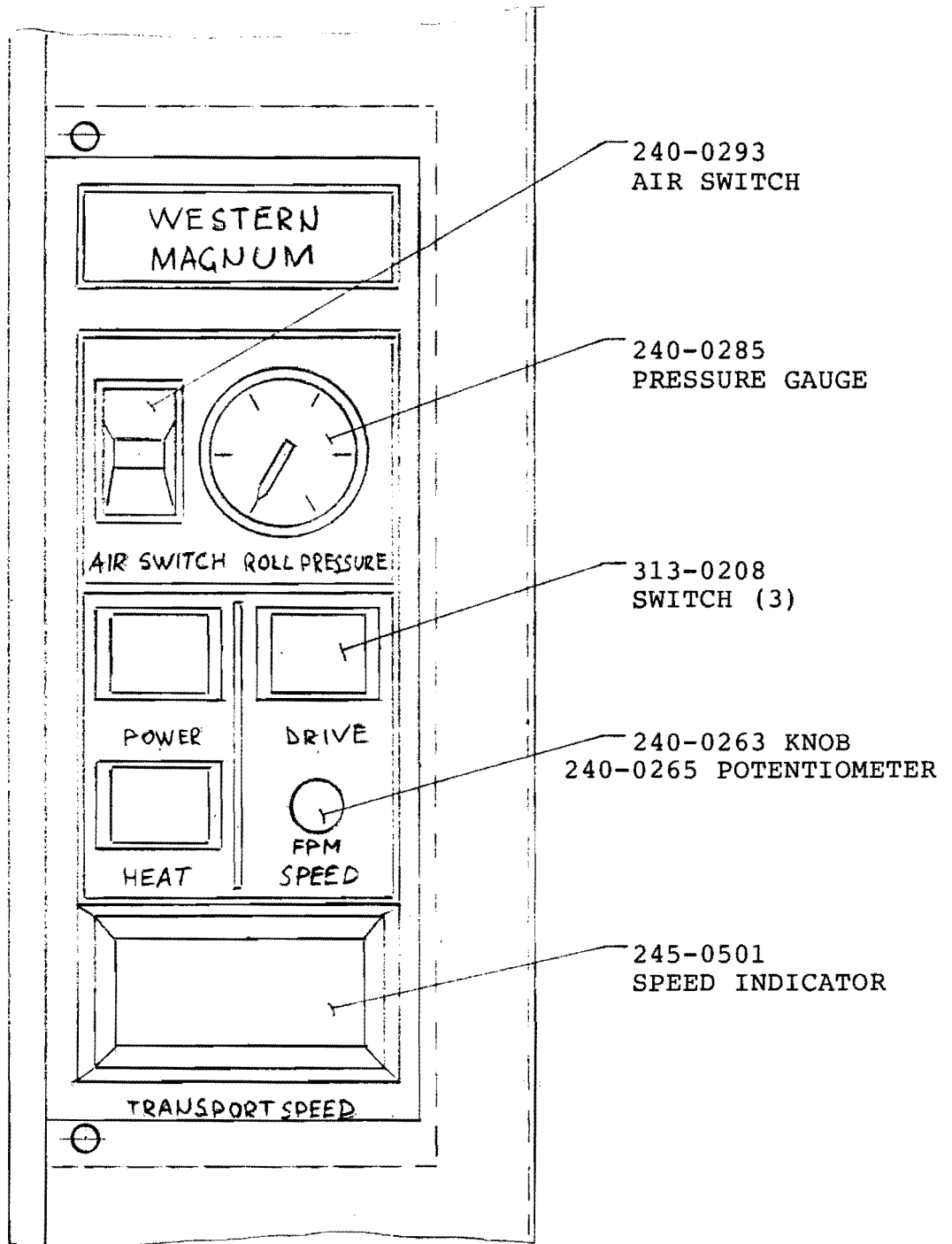

CONTROL PANEL, UPPER

FIGURE 13 A

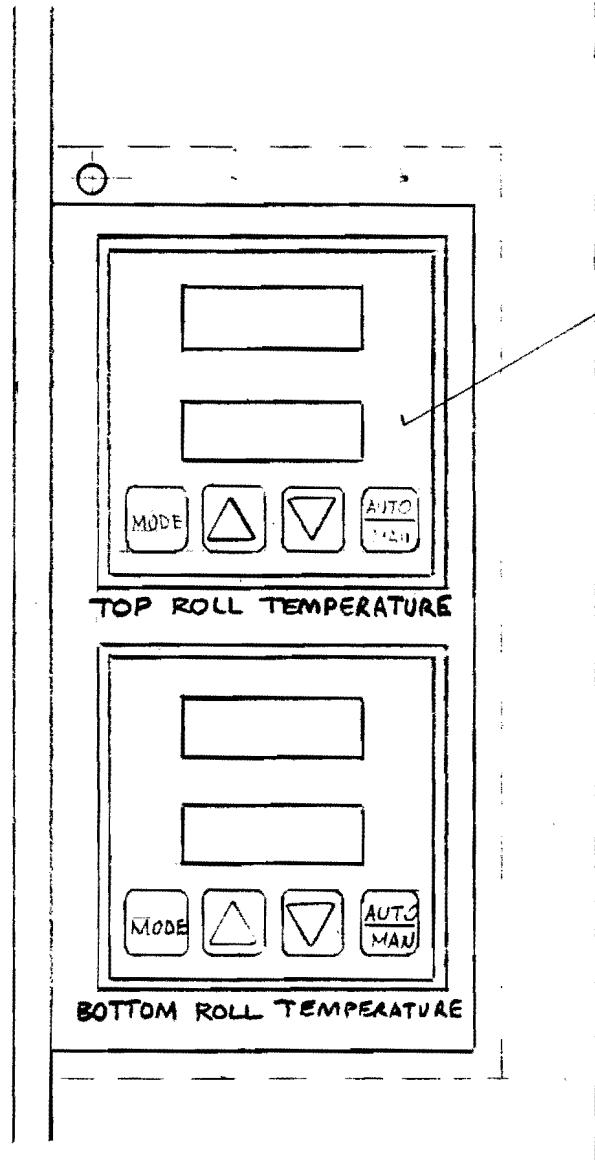

245-0518
Temperature
Controller
(see appendix)

CONTROL PANEL, LOWER

FIGURE 13 B

85

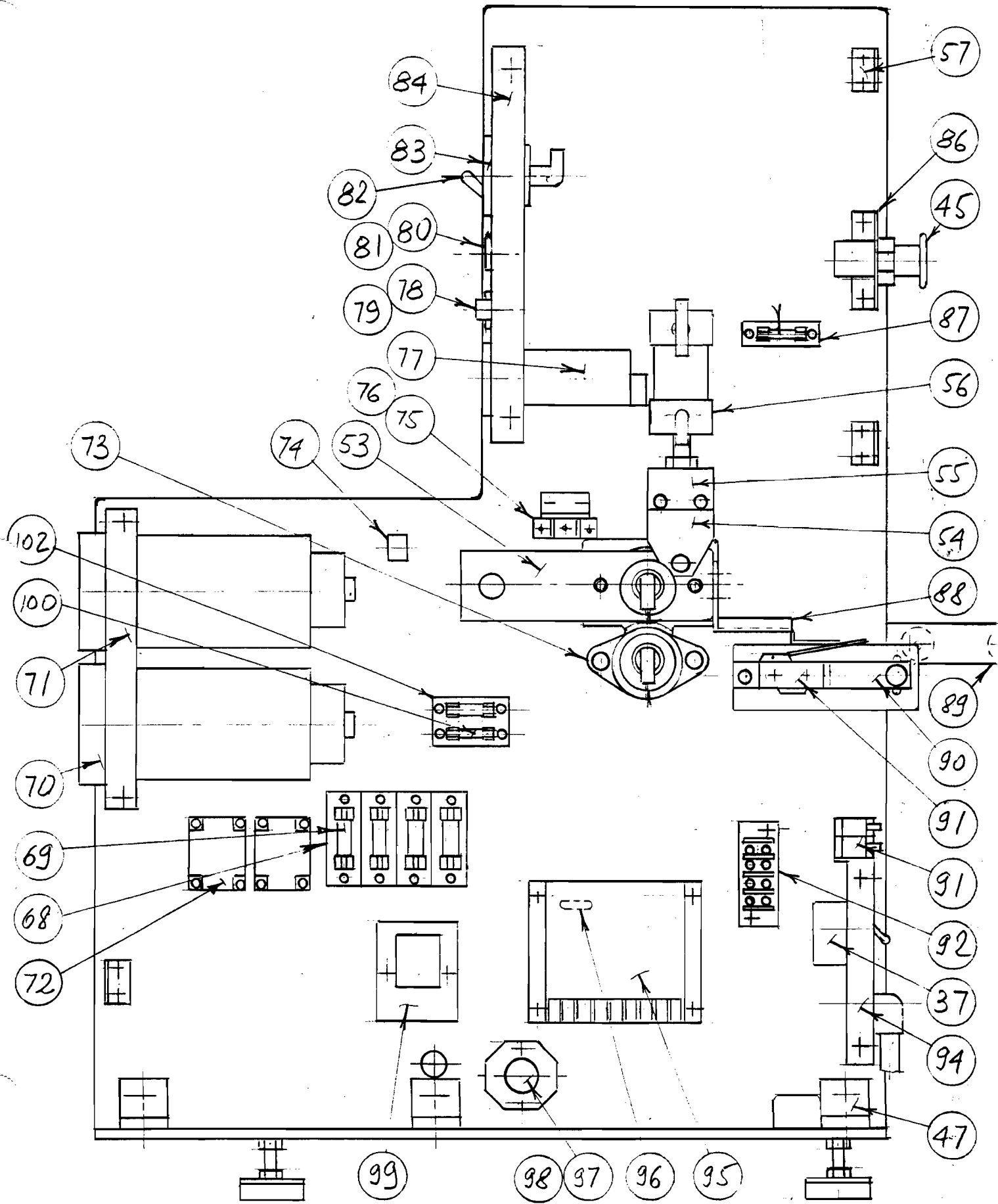

FIGURE 14

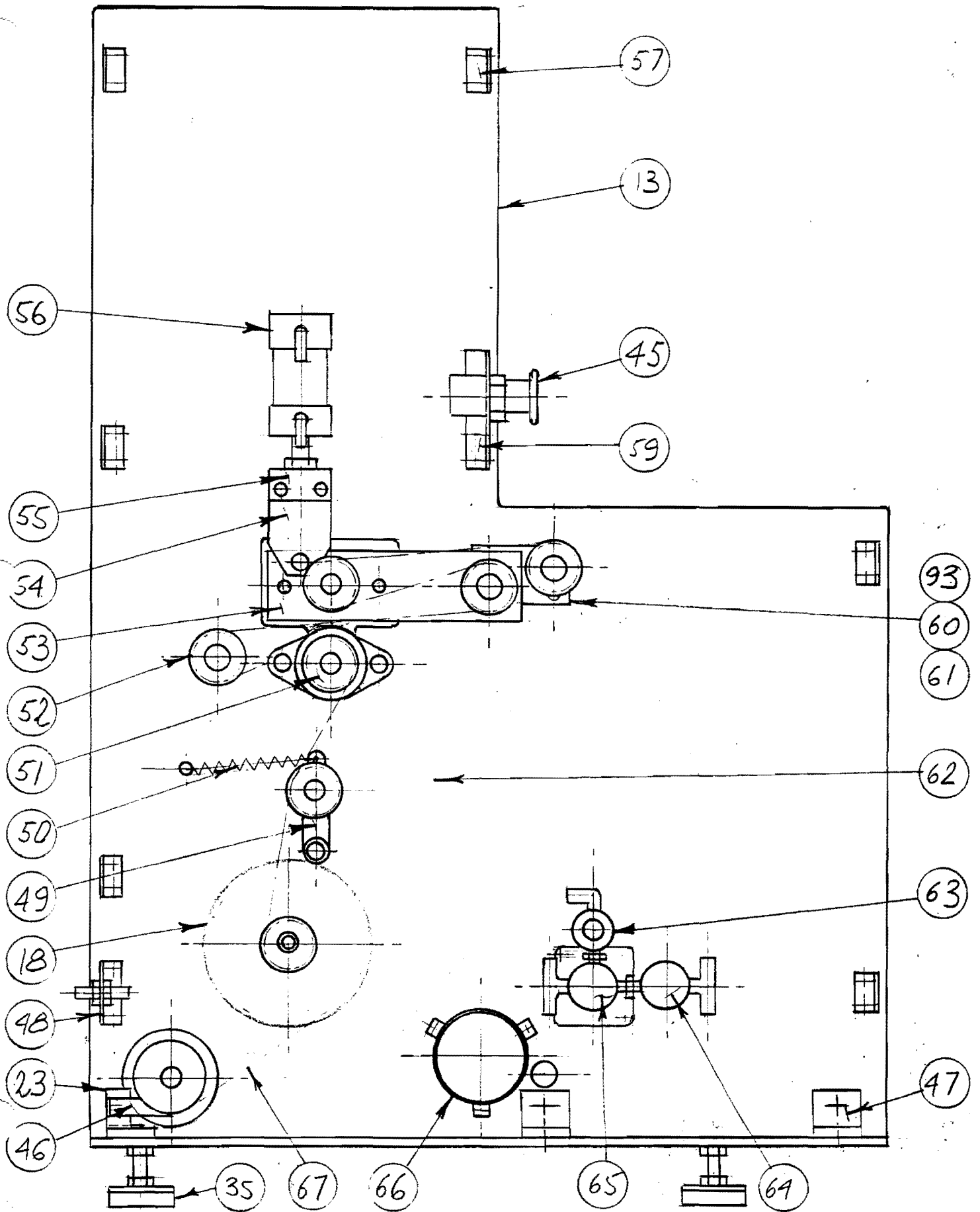

FIGURE 15

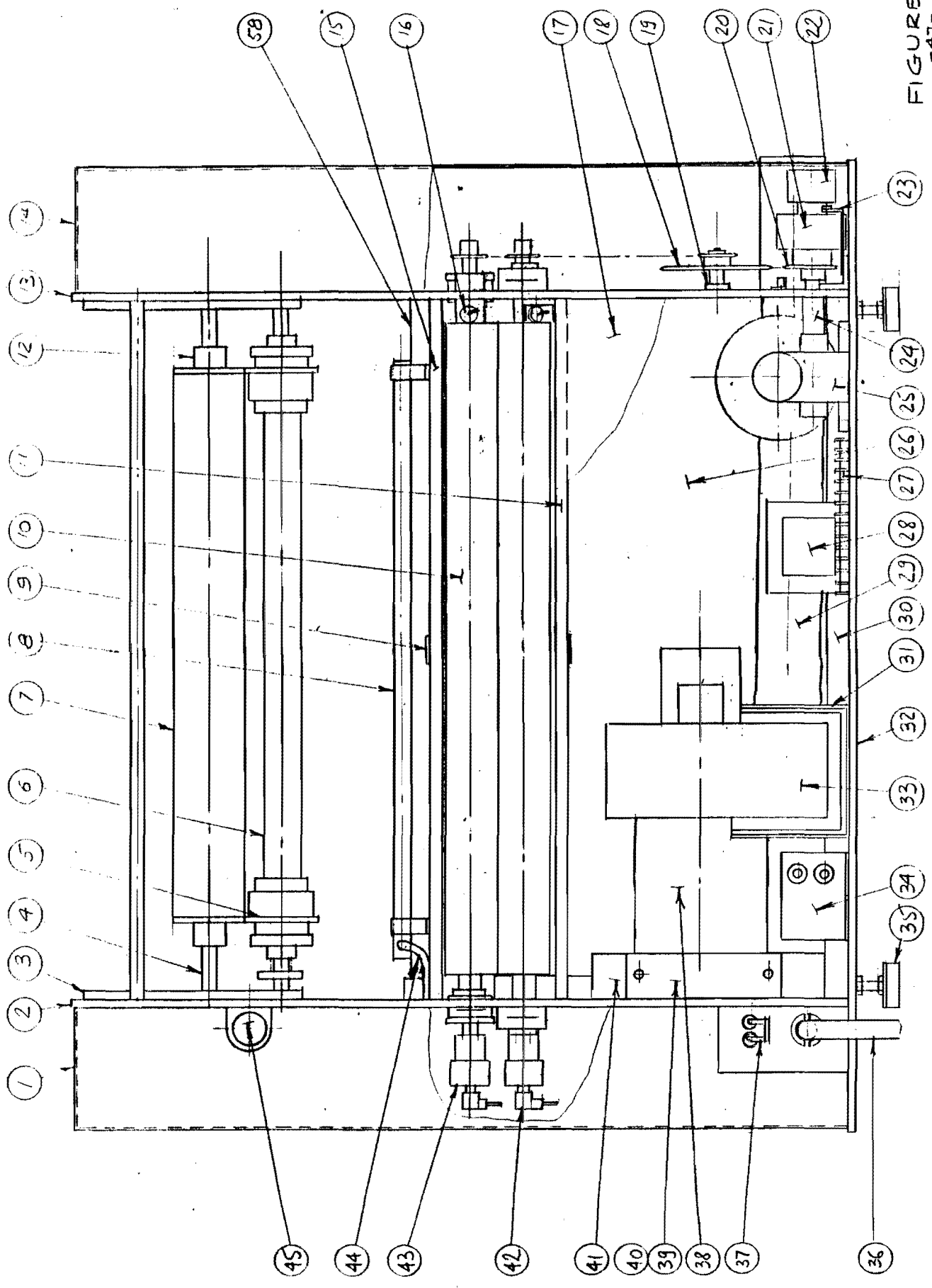

FIGURE 16
-41-

PARTS LIST

<u>ITEM NO.</u>	<u>PART NUMBER</u>	<u>DESCRIPTION</u>	<u>REQ'D</u>
1	245-0008	SIDE COVER, RIGHT	1
2	245-0005	SIDE PLATE, SUPPORT	1
3	240-0008	PLATE, SHAFT SUPPORT	4
4	240-0065	SHAFT, TAKE-UP	2
5	240-0092	COLLET ASSEMBLY 3"	4
5A	240-0095	EXPANSION RING, 6"	4
6	240-0072	TUBE, SUPPLY ROLL	2
7	240-0128	TUBE, CORE-TAKE UP ROLLER	2
8	340-0348	BAR, ANTI-STATIC	2
9	240-0104	THERMOCOUPLE ASSEMBLY	2
10	240-0017-3	PRESSURE ROLLER	2
11	240-0011-1	BAR, TIE-SQUARE (BOTTOM)	1
12	240-0021	HUB, TAKE-UP	4
13	245-0006	SIDE PLATE, LEFT	1
14	245-0009	SIDE COVER, LEFT	1
15	240-0011-2	BAR, TIE-SQUARE (TOP)	1
16	240-0251	BRUSH, CARBON (HOLDER)	2
17	240-0061	COVER, REAR	1
18	240-0153	SPROCKET ASSEMBLY, JACKSHAFT	1
19	240-0024	SUPPORT, JACKSHAFT	1
20	240-0152	SPROCKET, CLUTCH	1
21	240-0342	CLUTCH	1
22	245-0502	OPTICAL ENCORDER	1
23	240-0155	BRACKET, CLUTCH	1
24	245-0012	EXTENSION, SHAFT-DRIVE MOTOR	1
25	240-0201	MOTOR-DRIVE	1
26	240-0060	SHROUD, MOTOR & BLOWER	1

27	240-0215	TERMINAL BLOCK, 14 POLE	1
28	240-0219	TRANSFORMER, 240V/120V, 50/60 HZ	1
29	240-0241	DUCTING, 3 INCH	1
30	240-0014	ANGLE, STIFFENER-BASE	2
31	240-0058	FLANGE, BLOWER OUTLET	1
32	245-0007	BASE PLATE	1
33	240-0205	BLOWER	1
34	340-0350	POWER SUPPLY, ANTISTATIC BAR	1
35	240-0302	FOOT PAD ASSEMBLY	4
36	240-0222	CORD, 3 COND., 12 GAUGE	1
37	240-0206	CIRCUIT BREAKER, 15 AMP	2
38	340-0321	DUCTING, FLEXIBLE 6"	1
39	240-0056	FRAME, FILTER	1
40	240-0207	FILTER, AIR (WIRE MESH)	1
41	240-0055	PLENUM, AIR EXHAUST	1
42	550-0514	TERMINAL, SLIP RING	4
43	245-0042	COUPLING, SHAFT	2
44	340-0354	CORD, POWER-ANTISTATIC BAR	2
45	240-0344	SWITCH, PUSH BUTTON	2
46	245-0013	BRACKET, ENCODER	1
47	240-0012	ANGLE, SIDE PLATE	6
48	240-0114	BRACKET, AIR INLET	1
49	700-0115-2	CHAIN, TENSIONER	1
50	240-0255	SPRING EXTENSION, CHAIN TENSIONER	1
51	240-0096	SPROCKET	2
52	240-0217	SPROCKET	4
53	240-0036	PLATE, BEARING	2
54	245-0014	PLATE, AIR CLAMP	2

55	240-0106	BLOCK, AIR CLAMP	2
56	240-0282	AIR CYLINDER	2
57	240-0062	ANGLE, COVER RETAINING	9
58	240-0027	DUCT, EXHAUST	1
59	240-0156	BRACKET, SWITCH (FRONT)	1
60	245-0022	PLATE, SUPPORT-BEARING	1
61	245-0023	PLATE, SPACER-SPROCKET	1
62	240-0257-1	CHAIN, CUT-LONG	1
63	240-0284	REGULATOR	1
64	240-0299	VALVE, SOLENOID-AIR	1
65	313-0211	VALVE, SOLENOID-AIR	1
66	245-0021	DUCT, EXHAUST OUTLET	1
67	240-0257-2	CHAIN, CUT-SHORT	1
68	240-0266	FUSE HOLDER	4
69	240-0262	FUSE, 6 AMP	4
70	245-0518	CONTROLLER, TEMPERATURE	2
71	245-0011	BRACKET, CONTROL-TEMPERATURE	1
72	245-0519	SOLID STATE RELAY	2
73	240-0218	BEARING	4
74	240-0212	SWITCH, MOMENTARY REVERSE	1
75	245-0015	BRACKET, SWITCH	1
76	245-0503	MICROSWITCH	1
77	245-0501	DIGITAL SPEED INDICATOR	1
78	240-0263	KNOB, MOTOR CONTROL	1
79	240-0265	POTENTIOMETER, MOTOR CONTROLLER	1
80	313-0208	SWITCH	3
81	313-0215	LENS, SWITCH-AMBER	3
82	240-0293	SWITCH, ROCKER-AIR ON	1
83	240-0283	PRESSURE GAUGE 0-100#	1

84	245-0010	PANEL, CONTROL	1
85	712-0211	FUSE, 3 AMP	1
86	240-0161	BRACKET, SWITCH-REAR	1
87	245-0504	FUSE HOLDER	1
88	240-0111	BRACKET, SWITCH-ACTUATOR	1
89	240-0098	EXIT TABLE ASSEMBLY	1
90	240-0112	ARM, SWITCH MOUNTING	1
91	240-0214	SWITCH, LEVER	3
92	240-0216	TERMINAL BLOCK, 4 POLE	1
93	245-0024	SPACER, IDLER SPROCKET	2
94	240-0057	PANEL, POWER ENTRY	1
95	240-0202	CONTROLLER, MOTOR	1
96	240-0272	FUSE, CONTROLLER	1
97	240-0343	POWER SUPPLY, CLUTCH	1
98	200-0508	SOCKET, RELAY MOUNTING	1
99	240-0220	RELAY, POWER-DPDT	1
100	550-0514	CONNECTOR, 90 DEGREE	1
101	245-0520	SLIP RING	1

SECTION VI

SPARE PARTS

RECOMMENDED SPARE PARTS LIST
FOR
MODEL XRL-240 HOT ROLL LAMINATOR

ITEM	DESCRIPTION	QTY	UNIT PRICE	EXT PRICE
240-0017-3	HOT ROLL	2	\$1,175.00	\$2,350.00
240-0104-1	IR THERMOCOUPLE ASSEMBLY	2	\$348.00	\$696.00
240-0253-1	HEAT TRANSFER COMPOUND	1	\$28.00	\$28.00
245-0204	HEATER	1	\$250.00	\$250.00
245-0522	FUSE, 6 AMP	4	\$5.00	\$20.00
245-0518-1	TEMPERATURE CONTROLLER	1	\$475.00	\$475.00
245-0520	SLIP RING	1	\$110.00	\$110.00
712-0211	FUSE, 2 AMP	4	\$5.00	\$20.00
313-0208	SWITCH, CONTROL PANEL	1	\$41.00	\$41.00
245-0519	RELAY	1	\$88.00	\$88.00
			TOTAL	\$4,078.00
OPTIONAL				
240-0202	DRIVE MOTOR CONTROLLER	1		\$389.00