

LXC701

Genset Controller User Manual

Ver1.1 Date: 2012/12/18

LXC701 Series



Software version

Date	Version	Note
2011-10-12	1.0	Original release.
2012-12-18	1.1	Add USB communication interface

Contents

1. Summary.....	3
2. Features.....	3
3. Specification.....	3
4. Display symbol and operation.....	4
4.1. Push button.....	4
4.2. LED.....	4
4.3. Operation.....	4
4.3.1. Man Start.....	5
4.3.2. Auto State.....	5
4.3.3. Stop State.....	5
5. Alarm.....	5
6. Parameters table(only adjust via pc).....	6
7. Terminal.....	7
8. Case dimensions.....	8
9. Typical connections.....	8
10. Product packaging.....	8

1. Summary

The Module LXC701 is an small Automatic Engine Control Module. It selects 3 kinds of working state(Manual, Auto, Stop), can pass panel light touch buttons artificially start/stop genset, also can through remote start signal input automatic starting generator, and can detect fault (low oil pressure, high water temperature, emergency stop alarm, over speed) automatically disconnect fuel relays and stop electromagnet to electric suction close. Panel LED indicator fault state, provide real and effective fault alarm signal.

2. Features



- ❖ The power supply a wide range (8~35) VDC, can adapt different starting battery voltage environment.
- ❖ With low oil pressure, high water temperature, over speed, and emergency stop, start failures and so on protection and instructions.
- ❖ Can provide charging generator excitation function.
- ❖ With idle speed control and ETS solenoid function.
- ❖ Speed signal depend on frequency of generator.
- ❖ Panel LED display various operation and alarm state.
- ❖ 2 relay fixed output port (fuel output, starting output).
- ❖ 3 a programmable output port, can set common alarm output, preheat output, idle control, stop output, and other functions. Provide PC programming port, genset work necessary various delay, output port definition, power threshold can via PC settings, PC only need a USB port.
- ❖ Built-in watch dog can never be dead halt, ensuring smooth program execution.
- ❖ Standard holes 67 * 67 ,inserted type connection terminals,flame retardant ABS plastic shell, 32-bit ARM MCU,Stable performance,easy installation.

3. Specification

- ❖ **DC supply:** (8~35) V.
- ❖ **Single-phase AC input:** AC (15~300) V (+ 20%) 50Hz/60Hz.
- ❖ **Five relay output(B+, 5A):** Crank output
Fuel output
Configurable output1
Configurable output2
Configurable output3
- ❖ **3 Digit input port:** connect to (B-) is active.
- ❖ **Power Consumption:** standby mode(12V: 0.3W, 24V: 0.4W),working (12V: 1W, 24V: 1.1W)
- ❖ **Operating Temperature Range:**-30~+70℃
- ❖ **Dimensions:** 72mm×72mm×38mm.
- ❖ **Panel cutout:** 67mm×67mm.
- ❖ **Weight:** 0.2kg.

4. Display symbol and operation

4.1. Push button

Symbol	Defined	Description
	Manual start button	Push this button, generator will start, and the module comes into manual state.
	Auto state button	Push this button, the module comes into auto state.
	Stop button	Push this button, generator will stop, and the module comes into stop state. In the standby mode, if long pressing the button for 3 seconds all LED lights.

4.2. LED

Symbol	Defined	Description
Running	Running led	Before module crank successful, if there is no speed frequency, Light off. Otherwise, Flashing. After module crank successful, Lighten.
Emergency	Emergency stop alarm led	Lighten when emergent stop input is active.
High Water Temp.	High Water Temp alarm led	Lighten when high water temperature alarm is appearing.
Low Oil Press.	Low Oil pressure alarm led	Lighten when the module detects that the engine oil pressure has fallen below the low oil pressure pre-alarm setting level.
Over Speed	Over speed alarm led	Lighten when the engine speed has risen above the over speed pre alarm setting.
Charge Failure	Charge Failure alarm led	Lighten if the module does not detect a voltage from the alarm light terminal on the auxiliary charge alternator.
Low Battery	Low Battery alarm led	Lighten if the module detects that the plant DC supply has fallen below the low voltage setting level.
Over Crank	Over Crank alarm led	Light off when the module standby. Slow flashing when the module is in the process from preheating to crank. Lighten when module crank failure. Light off when after crank successful.
Common Alarm	Common Alarm led	Common alarm indication. Lighten off when there is no alarm. Slow flashing when there is warning alarm. Fast flashing when there is shutdown alarm. (Alarm include: emergency stop, high temperature, low oil pressure, over speed, under speed, charge failure, battery over voltage, battery under voltage, crank failure, stop failure, no gen)

4.3. Operation

Module has three states: stop state 、man state 、auto state .

4.3.1. Man Start

- ❖ When push Man start button  , preheat will first output, and start preheat delay, when preheat delay is end, fuel output 1 second, preheat output will stop, and crank output is start. Here engine will start, when crank successfully, crank output stop. Then engine comes into the safe time. When the safe time is end, then engine comes into the idle time. When the safe time is end, then idle output is out and engine will run at full tilt.

4.3.2. Auto State

- ❖ When push  button, the module will enter automatic state. Here if remote start input is active (connect to B-), the engine will start after the delay of start engine. Preheat will first output, and start preheat delay, when preheat delay is end, fuel output 1 second, preheat output will stop, and crank output is start. Here engine will start, when crank successfully, crank output stop. Then engine enter the safe delay. When the safe delay is end, then engine enter the idle delay. When the safe delay is end, then idle relay is close and genset raise high speed.
- ❖ When remote start input is inactive, the engine enter the idle process after the delay of engine stop, idle relay disconnect, fuel relays output after the idle delay, ETS solenoid output, genset will automatically stop, ETS solenoid disconnect when genset stop steady.

4.3.3. Stop State

- ❖ Push the  button when engine is running, the button beside led will lighten, enter idle process, idle relay disconnect, idle delay ended, fuel disconnect, ETS solenoid output, genset stop, ETS solenoid disconnect when genset stop steady.
- ❖ When engine is waiting state, push button 1 second above, ETS solenoid will output and all led will be Lighten. Loosen the stop buttons, ETS solenoid output disconnect instantly, and test lamps function is over.
- ❖ When engine is waiting state, only emergent stop alarm can be check.

5. Alarm

- ❖ **Low Oil Pressure:** check after the safe delay, the duration of 2 seconds above, the module will alarm and stop engine.
- ❖ **High Temperature:** check after the safe delay, the duration of 3 seconds above, the module will alarm and stop engine.
- ❖ **Over speed:** check after the preheat delay, the duration of 1.5 seconds above, the module will alarm and stop engine.
- ❖ **Under speed:** check when engine run at full tilt, the duration of 15 seconds above, the module will alarm and stop engine.
- ❖ **Charge Failure:** check when engine run at full tilt, the duration of 3 seconds above, and the module will warn but don't stop engine.
- ❖ **Over Crank:** when engine crank fail over the times of configure, the module will alarm and stop engine.
- ❖ **Stop Failure:** when engine is stop fail, the module will warn.
- ❖ **No generator:** check after the idle delay, when generator frequency for zero and the duration of 5 seconds above, the module will alarm and stop engine.
- ❖ **Battery over voltage:** The DC supply has risen above the high volts setting level for the duration of the high battery volts 20 seconds.

- ❖ **Battery under voltage:** The DC supply has low above the under volts setting level for the duration of the low battery volts 20 seconds.
- ❖ **Emergency Stop:** When emergency stop input, ETS solenoid stop immediately output, and then fuel disconnect, preheat and start signal emit emergency stop alarm signal.
- ❖ **Common Alarm:** when any alarm or warn is appear, this alarm will active. When the over speed, under speed, high temperature, low oil pressure, emergency stop, no generator, crank failure, stop failure alarm, battery over voltage, battery under voltage, common alarm LED illuminate, and common alarm output.

6. Parameters table(only adjust via pc)

Set the content as follows:

NO.	Parameter	Range	Default	Remark
1	Start delay	(0-3600s)	1s	It's the delay from remote start signal is active or mains is failure, to start generator.
2	Stop delay	(0-3600s)	5s	It's the delay from remote start signal is inactive or mains is normal, to stop generator.
3	Number of Crank	(1-9)	3	Numbers of crank cycles.
4	Preheat time	(0-300)S	0s	This timer dictates the duration that the pre-heat output will be active before an attempt is made to start the engine. Once this timer has expired cranking will commence.
5	Cranking time	(1-60)S	5s	This is the maximum amount of time that the module will energize the starter motor for during starting attempts once the starter has engaged.
6	Crank rest time	(3-60)S	10s	This is the amount of time the module will wait for between start attempts. This is to allow the starter motor to cool and the starter batteries to recover.
7	Safe running time	(1-60)S	10s	This timer dictates how long the module will ignore the Low oil pressure, High Engine Temperature, Under speed, Under volts and any other inputs configured as active from safety on.
8	Start idle time	(0-3600)S	0s	This is the amount of time that the start Idle speed is held active. These allow the engine to hold low speed.
9	Warming up delay	(0-3600)S	0s	
10	Cooling delay	(0-3600)S	0s	
11	Stop idle time	(0-3600)S	0s	This is the amount of time that the stop Idle speed is held active. These allow the engine to hold low speed.
12	ETS solenoid hold	(0-120)S	30s	This timer is used if the unit is configured to operate an Energize to stop engine. It dictates the duration that the ETS output will remain active after the module has detected the engine has come to rest. If the ETS output is not configured, this timer will still operate, preventing an immediate restart.
13	Fail to stop delay	(0-120)S	0s	Once the module has given a shutdown signal to the engine it expects the engine to come to rest. It monitors the Oil pressure and speed sensing sources and if they still indicate engine movement when this timer expires a 'Fail to stop' alarm signal is generated.
14	Close ATS time	(0-20)S	0s	Breaker close pulse. If it is set to zero, the output will held.
15	Open ATS time	(0-20)S	0s	Breaker open pulse. If it is set to zero, the output will held.
16	Condition of	(0-1)	1.Enable	The PC configuration choices: (Default :0. Freq)

	Crank--Freq			0:Freq
17	Condition of Crank--oil	(0-1)	0.Disable	1:Oil Pressure
18	Condition of Crank--D+	(0-1)	0.Disable	2:Freq+Oil Pressure
				3: D+
				4: Oil Pressure + D+
19	Freq disconnect	(5-30)Hz	10HZ	In the process of cranking, when the gens frequency exceeds this value, the starter will be separated.
20	D+ disconnect	(3-32)V	8V	
21	Frequency On Load	(10-70)Hz	48HZ	Gens normal when the gens frequency is greater than the frequency on load.
22	Gens over freq	(0-75)Hz	57HZ	When generator frequency is over than the point and hold great than 3 seconds, generator over frequency is active.
23	Gens under freq	(0-59)Hz	0HZ	When generator frequency is low than the point, generator low frequency and hold great than 15 seconds is active.
24	Battery over volt	(0-35)V	35V	When generator battery voltage is over than the point and hold for 20 seconds, battery over voltage signal is active. It's a warning alarm.
25	Battery under volt	(0-30)V	8V	When generator battery voltage is less than the point and hold for 20 seconds, battery under voltage signal is active. It's a warning alarm.
26	Charge failure volt	(0-30)V	4V	During generator is running, when charge alternator WL/D+ voltage is low than this point and remain for 5 seconds, generator will warning alarm.
27	Configurable output1	(0-16)	5.Idle output	0. not used
				9. Close Gens
				1. Common alarm
				10. Open Gens
				2. Preheat output
				11. Gen On Load
				3. Fuel relay output
				12. Louver Control
				4. Crank relay output
				13. Pre-Lubricate Output
				5. Idle control
				14. Ahead Fuel Output
				6. Energized To Stop output
				15. Air Flap Output
				7. Over speed output
				16. Excitation Output
				8. Running
28	Configurable output2	(0-16)	6. Energized To Stop output	
29	Configurable output3	(0-16)	1.Common Output	

7. Terminal

- ❖ **Terminal 1 (B-)** : connect to the cathode of battery.
- ❖ **Terminal 2(B+)**: connect to the anode of battery.
- ❖ **Terminal 3(Em. stop input)**: emergent stop input, connect to (B+) is active.
- ❖ **Terminal 4(Fuel Output)**: Fuel Output, (B+, 5A).
- ❖ **Terminal 5(Start Output)**: Start Output, (B+, 5A).
- ❖ **Terminal 6(Remote Start Input)**: Remote Start Input, connect to (B-) is active.
- ❖ **Terminal 7(D+)**: Connect to the terminal WL (or D+) of charger.
- ❖ **Terminal 8(LOP Input)**: Low oil pressure input, connect to (B-) is active.
- ❖ **Terminal 9(HWT. Input)**: High temperature input, connect to (B-) is active.
- ❖ **Terminal 10 (Configurable Output3)** : Configurable output, (B+, 5A).
- ❖ **Terminal 11 (Configurable Output2)** : Configurable output, (B+, 5A).
- ❖ **Terminal 12 (Configurable Output1)** : Configurable output, (B+, 5A).
- ❖ **Terminal 13 (N) 、 14 (L)** : Alternator Input.
- ❖ **USB Interface**: Controller directly through the USB line connected to the computer for parametric programming.

8. Case dimensions

(HOLE: 65*65mm)

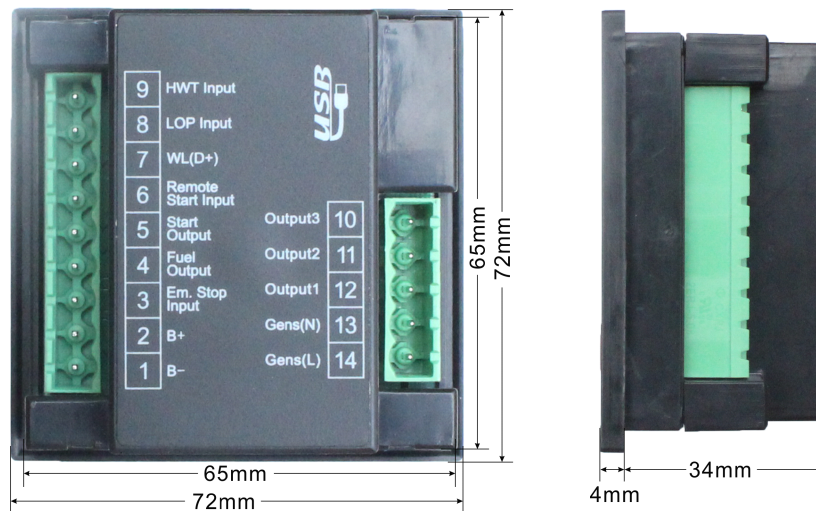

9. Typical connections

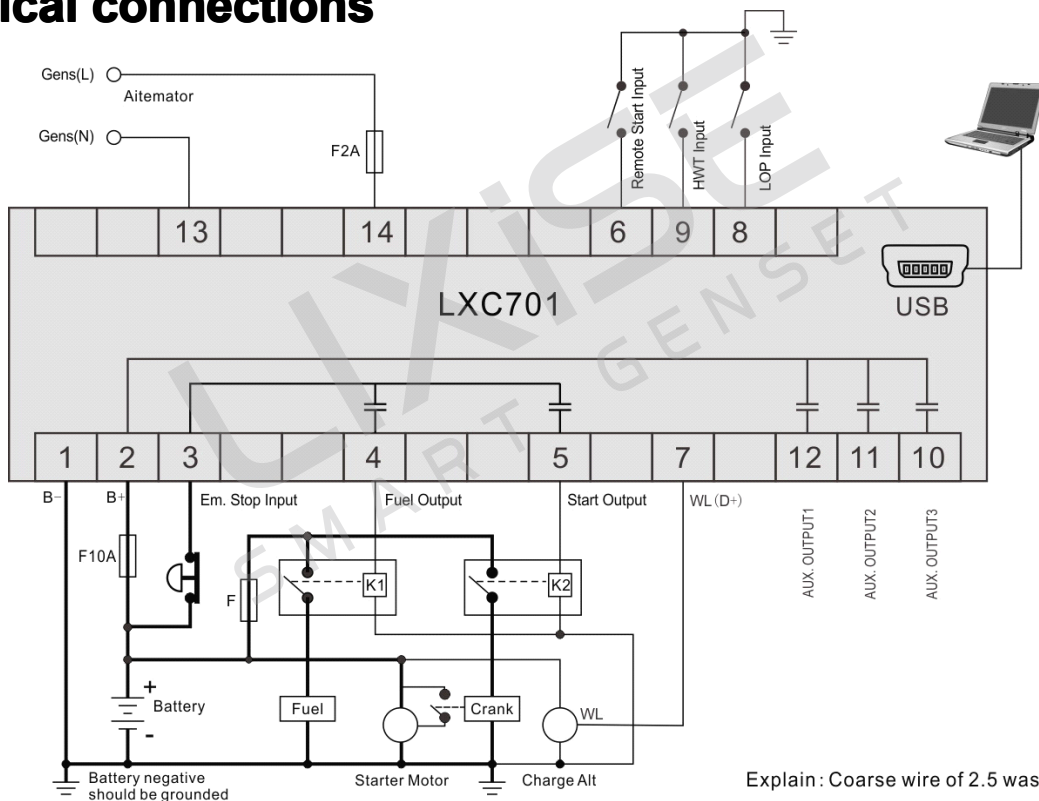

10. Product packaging

This product should be following sets:

- (1) 1 piece of controller model **LXC701**;
- (2) 2 piece of fixed cards;
- (3) 1 piece of product certificate;
- (4) 1 piece of product manual.

Dongguan Tuancheng Automation Equipment Co.,LTD.

Tel:+86-769-23836636

Fax:+86-769-23166296

http://www.lixise.com

http://www.lixise.net

E-mail:sales@lixise.com

Add: Wentang Road, Chashang industrial zone #18, Dongcheng, Dongguan, Guangdong, China