

A SELECTION FROM THE VAST RANGE OF

CHAMP-ROB®

QUALITY PRODUCTS



AIR COMPRESSORS

From DIY to industrial. Plus air tools, spray guns and accessories.

GENERATORS

From duty or emergency standby for business, home and leisure.

POWER WASHERS

Hot and cold, electric and engine driven - we have what you need.

WELDERS

Mig, Arc, Tig and Spot. From DIY to auto/industrial.

METALWORKING

Drills, grinders and saws for DIY and professional use.

WOODWORKING

Saws, sanders, lathes, mortisers and dust extraction.

HYDRAULICS

Chairs, body repair kits, transmission jacks for all types of workshop use.

WATER PUMPS

Superior, electric and engine driven for DIY, agriculture and industry.

POWER TOOLS

Angle grinders, cordless drill sets, saws and sanders.

STARTER/CHARGERS

All sizes for car & commercial use.

CHAMP-ROB INTERNATIONAL

Hemmell Street, Epping, Essex, CM16 4LG, ENGLAND

Telephone: 01992 565333 Fax: 01992561562

e-mail: Partschachtel@champrobandinternational.com

For spares and servicing, please contact your nearest dealer, or Clarke International on 020-6988-7400

CHAMP-ROB®

METALWORKER

BENCH GRINDER

MODEL CBG6RZ



OPERATING & MAINTENANCE
INSTRUCTIONS



Clarke[®]
INTERNATIONAL

Clarke[®]
INTERNATIONAL

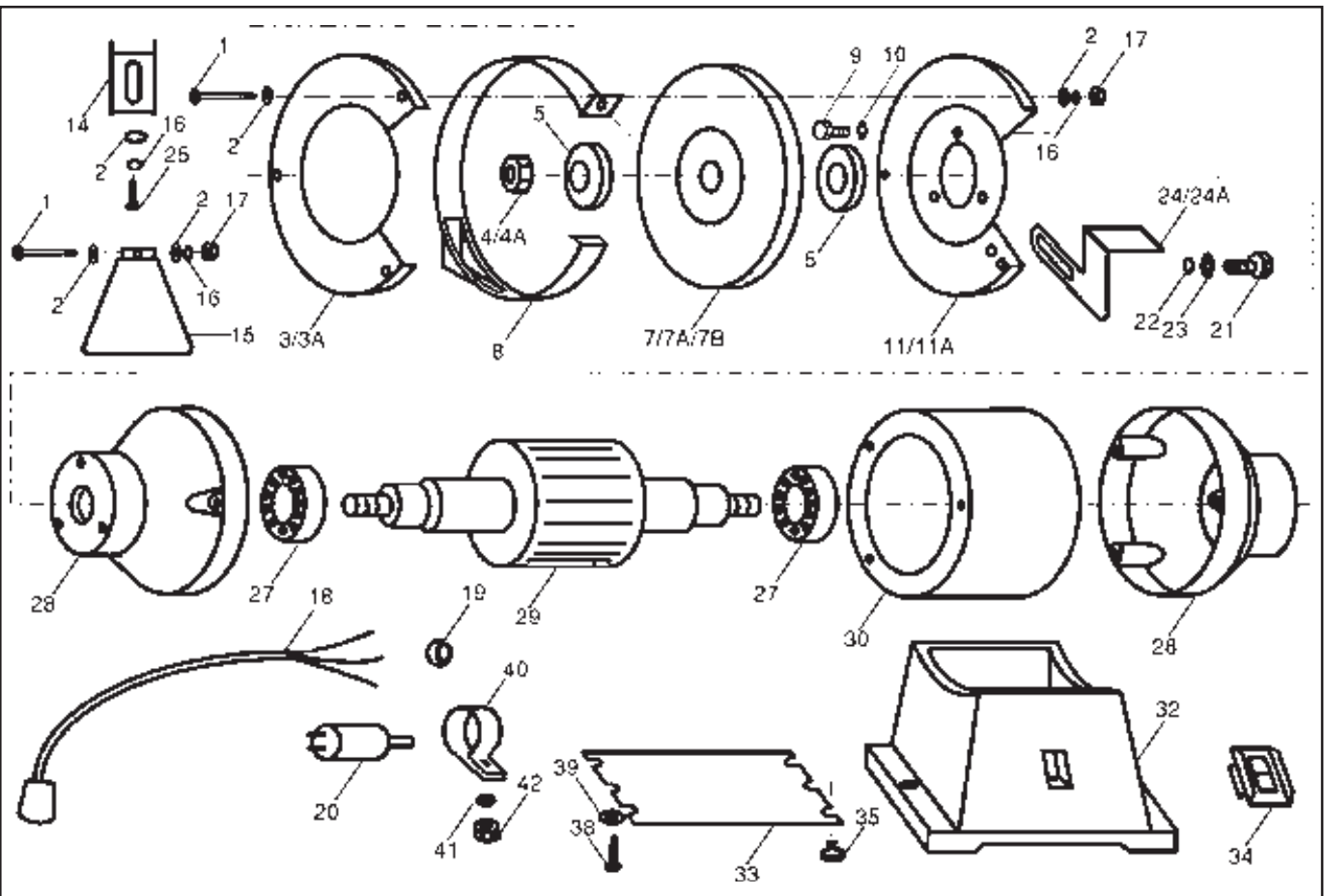

Thank you for purchasing this CLARKE BENCH GRINDER. Before attempting to operate this machine, please read this instruction manual thoroughly and follow all directions carefully. By doing so you will ensure the safety of both yourself and others around you, and at the same time, you should look forward to long and trouble free service from your Bench Grinder.

GUARANTEE

This product is guaranteed against faults in manufacture for 12 months from purchase date. Keep your receipt as proof of purchase. This guarantee is invalid if the product has been found to have been abused in any way, or not used for the purpose for which it was intended, or to have been tampered with in any way. The reason for return must be clearly stated. This guarantee does not affect your statutory rights.

CONTENTS

PAGE

Guarantee, General Safety Rules	2
Special Safety Rules for Grinders	3
Pre Assembly Check	4
Electrical Connections, Fuse Rating	5
Assembly, (Eyesield and Toolrest)	6
Maintenance (Incl. changing the grinding wheel)	7
Technical data	7
Parts List and Diagram	8

GENERAL SAFETY RULES

1. KEEP GUARDS IN PLACE and check they are not damaged.
2. REMOVE ADJUSTING KEYS AND WRENCHES. Make a habit of checking to see that all adjusting keys and wrenches are removed from the machine before turning it on.
3. KEEP WORK AREA CLEAN. Cluttered areas and work benches invite accidents.
4. DO NOT USE IN A DANGEROUS ENVIRONMENT. Do not use any power tools in damp or wet areas, or expose them to rain. Keep work area well lit.
5. KEEP CHILDREN AWAY. All visitors, but in particular children, should be kept at a safe distance away from the work area.
6. MAKE YOUR WORKSHOP CHILDPROOF with padlocks, master switches, or by removing starter keys.
7. DO NOT FORCE YOUR BENCH GRINDER. It will do a better and safer job if used at the rate for which it was designed.

8. USE THE RIGHT TOOL. Do not force your tool or attachment to do a job for which it was not designed.
9. WEAR THE PROPER APPAREL. No loose clothing, gloves, neckties, rings, bracelets, or any other jewelry which might get caught in moving parts. Non-slip footwear is recommended. Wear protective hair covering to contain long hair.
10. ALWAYS USE SAFETY GLASSES. Everyday glasses only have impact resistant lenses, they are not safety glasses. Also use a face mask if grinding operation is generating a lot of dust.
11. DO NOT OVERREACH. Keep a firm footing and proper balance at all times.
12. DISCONNECT FROM THE MAINS before attempting any kind of service work or adjustment or when changing accessories such as grinding wheels.
13. MAINTAIN TOOLS WITH CARE. Keep tools sharp and clean for best and safest performance.
14. REDUCE THE RISK OF UNINTENTIONAL STARTING. Make sure switch is in the OFF position before plugging in.
15. CHECK FOR DAMAGED PARTS. Before further use of tool, any damaged part should be carefully inspected and checked to determine that it will operate properly and perform its intended function. Check for alignment of moving parts, binding of moving parts, mounting, and any other damage that may affect its operation. A guard or other part that is damaged should be properly repaired or replaced. If in any doubt contact your local dealer.

SPECIAL SAFETY RULES FOR BENCH GRINDERS

1. Replace a cracked wheel immediately.
2. Always use guards and eyeshield.
3. Do not overtighten wheel nut.
4. Adjust distance between wheel and tool rest to maintain 1/16" (1.6mm) or less separation as the diameter of the wheel will decrease with use.
5. Use a grinding wheel suitable for the speed of grinder. (See technical data).
6. Stand slightly to one side of the bench grinder during operation, not facing directly in front.
7. One minute of free rotation is necessary for a new grinding wheel; should the new grinding wheel be faulty and break, it will happen within the first minute of operation.
8. Do not remove the wheel guard except when changing a worn wheel.
9. Do not use the grinding wheel for any kind of cutting.
10. Do not over stress the grinding wheel.
11. Use a file to remove burrs from the grinding wheel.
12. NEVER LEAVE A GRINDER RUNNING UNATTENDED. TURN POWER OFF. Do not leave tool until it comes to a complete stop.

PARTS LIST & DIAGRAM

No. Description	Part No.	No. Description	Part No.
1 Bolt	HT6481901	20 Capacitor	HT6481920
2 Washer	HT6481902	21 Screw	3040528
3 Outer Protection Cover LH	HT6481903	22 Spring Washer	3040582
3A Outer Protection Cover RH	HT6481903A	23 Flat Washer	3044576
4 Wheel lock nut LH	HT6481904	24 Tool Rest LH	HT6481924
4A Wheel lock nut RH	HT6481904A	24A Tool Rest RH	HT6481924A
5 Wheel Flange	HT6481905	25 Screw	HT6481925
7 Grinding Wheel (Coarse)	6501088	26 Spring Washer	HT6481926
7A Grinding Wheel (Medium)	6501089	27 Bearing	HT6481927
7B Grinding Wheel (Fine)	6501135	28 Main Body End Cover	HT6481928
8 Middle Ring	HT6481908	29 Rotor /Shaft	HT6481929
9 Screw	HT6481909	30 Stator/Body	HT6481930
10 Spring Washer	HT6481910	32 Base	HT6481932
11 Inner Protection Cover LH	HT6481911	33 Bottom Plate	HT6481933
11A Inner Protection Cover RH	HT6481911A	34 Switch Assy.	HT6481934
14 Eye Shield Bracket	HT6481914	35 Rubber Foot	HT6481935
15 Eye Shield	HT6481915	38 Screw	HT6481938
16 Spring Washer	HT6481916	39 Washer	HT6481939
17 Nut	HT6481917	40 Capacitor Bracket	HT6481940
18 Power Cable	HT6481918	41 Washer	HT6481941
19 Cable Clamp	HT6481919	42 Nut	HT6481942

For Spare Parts and Servicing, please contact your nearest dealer, or CLARKE International, on one of the following numbers.

PARTS & SERVICE TEL: 020 8988 7400

PARTS & SERVICE FAX: 020 8558 3622

or e-mail as follows:

PARTS: parts@clarkinternational.com

SERVICE: service@clarkinternational.com

MAINTENANCE

(A) EYESHIELD and SPARK ARRESTER BRACKET ADJUSTMENT

The see-through eye shields allow the user to see the operation clearly and to work precisely. The eye shields can be adjusted up and down to suit operator.

The Spark Arrester brackets should be adjusted so that they are as close as possible to the wheel without impairing the wheels rotation.

(B) TOOLREST ADJUSTMENT

The appropriate adjustment of the Tool Rests provides the operator with a correct working angle and a firm and efficient base for working. Adjustments can be made by loosening the mounting screws and moving the Tool Rest to within 1/16" (1.6mm) from the wheel. Due to the wear on the grinding wheel, it will be necessary to adjust the Tool Rests from time to time. Always re-tighten the mounting screws once adjustment is complete.

(C) CHANGING THE GRINDING WHEEL

To renew or change the grinding wheels, follow the steps given below.

1. Switch off and un-plug from mains power supply. Disassemble outer covers, left or right, by removing the three cover retaining nuts, bolts and washers.
2. Slacken the Spark Arrester bracket and Tool Rest mounting screws, and pull the bracket and Tool Rest away from the wheel.
3. Hold the grinding wheel firmly and remove the nut and flange from the shaft, noting that the left hand wheel nut has a left hand thread.
4. Take off the used wheel and replace with the new one, ensuring:
 - a. the paper blotters are in place either side of the wheel.
 - b. that there is a good balanced rotation of the grinding wheel, and
 - c. you do not overtighten the wheel nut.
5. Readjust the Tool Rest and Spark Arrester Brackets as described above.
6. Switch ON the machine and allow it to rotate freely for at least one minute.

TECHNICAL DATA

MOTOR	230V ~ 50HZ; 1Pn
SPEED	2800 RPM
POWER RATING	210Watts
FUSE RATING	5 Amps
WHEEL SIZE	150 x 20 x 12.7 mm
GRINDING WHEELS	1 x Fine; 1 x Coarse
WEIGHT (Packed)	9 KG
DUTY CYCLE	5/5 min.
PART NO.	6500105

13. USE ONLY APPROVED REPLACEMENT GRINDING WHEELS. Contact your local dealer or Clarke International (081-558 6696) for approved replacement grinding wheels and accessories. The use of inferior accessories may cause risk of injury.
14. Never use the side of the grinding wheel. Use only the front face.

PRE-ASSEMBLY CHECK

Before assembling your Bench Grinder, please check to ensure that all the parts, shown below, have been included.

Note: if any parts are missing or damaged, please contact your local dealer or Clarke International on 081-558 6696 for replacement.

1. Main Body (switch and power cable with plug are included).
2. Two Eyeshields, each complete with 1 x nut, 1 x bolt, 1 x spring washer and 2 x flat washers (A).
3. Two spark arrester brackets, each complete with 1 x screw, 1 x spring washer and 1 x flat washer (B).
4. Two Tool rests, each complete with 2 x screws, 2 x spring washers and 2 x flat washers (C).

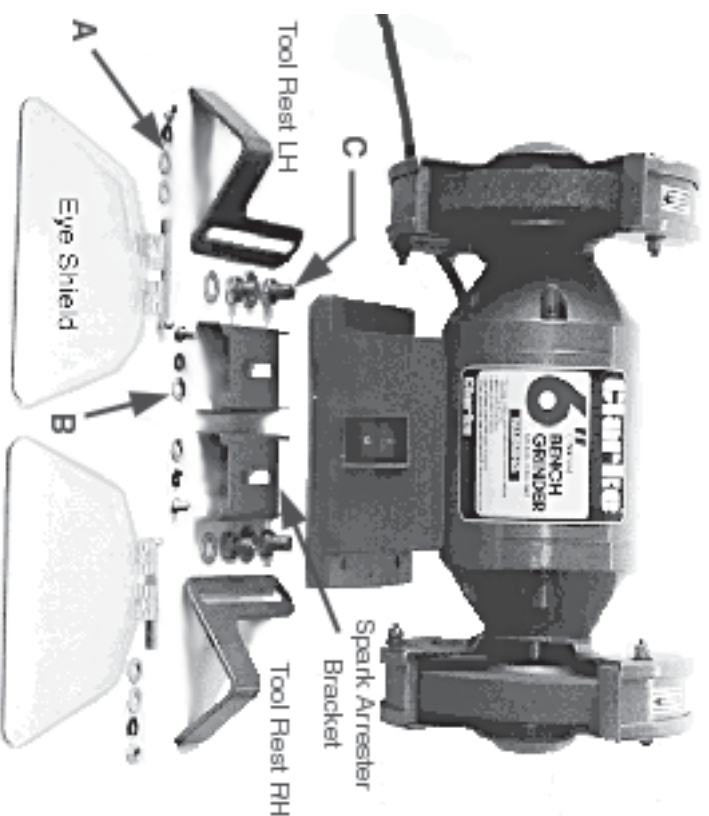

ELECTRICAL CONNECTIONS

Connect the mains lead to a standard, 240 volt (50Hz) electrical supply through a fused good quality (rubber preferred) 13 amp BS 1363 plug, or a suitable fused isolator switch.

WARNING: THIS APPLIANCE MUST BE EARTHED

IMPORTANT: The wires in the mains lead are coloured in accordance with the following code:

Green & Yellow	---	Earth
Blue	---	Neutral
Brown	---	Live

As the colours of the flexible cord of this appliance may not correspond with the coloured markings identifying terminals in your plug, proceed as follows:

Connect **GREEN & YELLOW** cord to terminal marked with a letter "E" or Earth symbol \equiv or coloured **GREEN** or **GREEN & YELLOW**.

Connect **BROWN** cord to terminal marked letter "L" or coloured **RED**.

Connect **BLUE** cord to terminal marked letter "N" or coloured **BLACK**.

We recommend that this unit is fitted with a Residual Current Device (RCD).

FUSE RATING

The fuse in the plug for this appliance must be rated at **5 amps**.

IMPORTANT NOTICE

If this appliance is fitted with a plug which is moulded onto the electric cable (i.e. non rewirable) please note:

1. This plug must be thrown away if it is cut from the electric cable. There is a danger of electric shock if it is subsequently inserted in a socket outlet.
2. Never use the plug without the fuse cover fitted.
3. Should you wish to replace a detachable fuse carrier, ensure that the correct re-placement is used (as indicated by marking or colour code).
4. Replacement fuse covers can be obtained from your local dealer, an electrical stockist, or CLARKE INTERNATIONAL Spares Department (tel. 020 8988 7400).
5. The fuse in the plug must be replaced with one of the same rating (see wiring/ electrical connection section in the instruction manual) and this replacement must be ASTA approved to BS1362.

ASSEMBLY

1. Fix the Tool Rests, with the screws and washers provided, in the manner shown in Fig. 1. The Tool Rests are adjustable and should be positioned 1/16" (1.6mm) from the grinding wheels. Ensure that the Tool Rest is firmly fixed and horizontal.
2. Assemble the Spark Arrester brackets onto the wheel guards, using the screws and washers provided, in the manner shown in Fig. 2.

NOTE: Before fully tightening the screws, each bracket should be adjusted by sliding it as close to the grinding wheels as possible, without impairing the wheels rotation. As the wheel wears down with use, it will be necessary to re-adjust the Spark Arrester brackets accordingly.

3. Assemble the Eye Shields on to the Spark Arrester brackets using the nuts, bolts and washers supplied, in the manner shown in Fig. 3. The angle for the Eye Shields can be adjusted to suit the operator.

4. We recommend that your Clarke Bench Grinder is secured to your workbench before operation, using the pre-drilled holes in the base. Do not overtighten the mounting bolts as this could damage the plastic base.

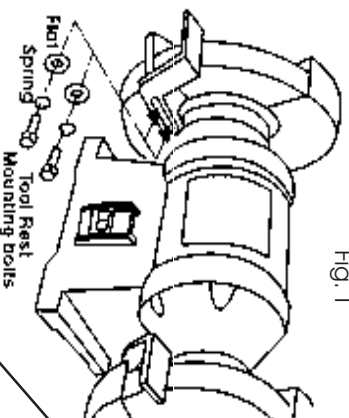

Fig. 1

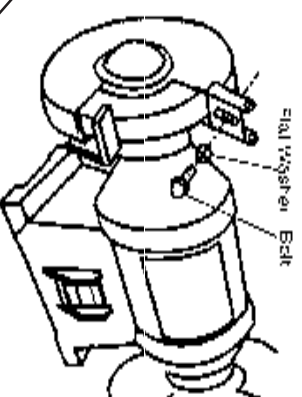

Fig. 2

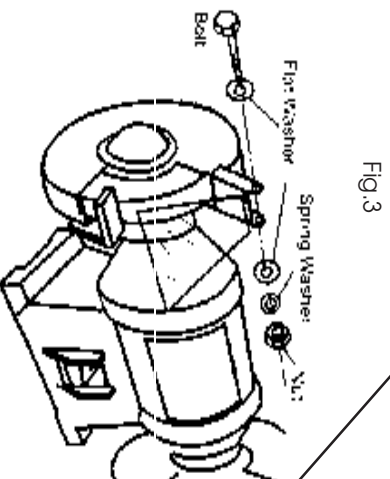

Fig. 3